



US 20170331331A1

(19) **United States**

(12) **Patent Application Publication**  
**Zeine et al.**

(10) **Pub. No.: US 2017/0331331 A1**

(43) **Pub. Date: Nov. 16, 2017**

(54) **TECHNIQUES FOR CALIBRATING WIRELESS POWER TRANSMISSION SYSTEMS FOR OPERATION IN MULTIPATH WIRELESS POWER DELIVERY ENVIRONMENTS**

*H02J 50/90* (2006.01)

*H02J 7/04* (2006.01)

*H02J 50/80* (2006.01)

(52) **U.S. Cl.**

CPC ..... *H02J 50/20* (2016.02); *H02J 7/042*

(2013.01); *H02J 50/80* (2016.02); *H02J 50/90*

(2016.02); *H02J 7/025* (2013.01)

(71) Applicant: **Ossia Inc.**, Bellevue, WA (US)

(72) Inventors: **Hatem Zeine**, Bellevue, WA (US); **Dale Mayes**, Bothell, WA (US); **Douglas Williams**, Bellevue, WA (US); **Siamak Ebadi**, Bellevue, WA (US)

(57) **ABSTRACT**

(73) Assignee: **Ossia Inc.**, Bellevue, WA (US)

(21) Appl. No.: **15/596,661**

(22) Filed: **May 16, 2017**

**Related U.S. Application Data**

(60) Provisional application No. 62/337,147, filed on May 16, 2016.

**Publication Classification**

(51) **Int. Cl.**

*H02J 50/20* (2006.01)

*H02J 7/02* (2006.01)

The technology described herein relates to techniques for calibrating wireless power transmission systems for operation in multipath wireless power delivery environments. In an implementation, a method of calibrating a wireless power transmission system for operation in a multipath environment is disclosed. The method includes characterizing a receive path from a calibration antennae element to a first antennae element of a plurality of antennae elements of the wireless power transmission system, characterizing a transmit path from the first antennae element to the calibration antennae element, and comparing the transmit path to the receive path to determine a calibration value for the first antennae element in the multipath environment.

100 ↘

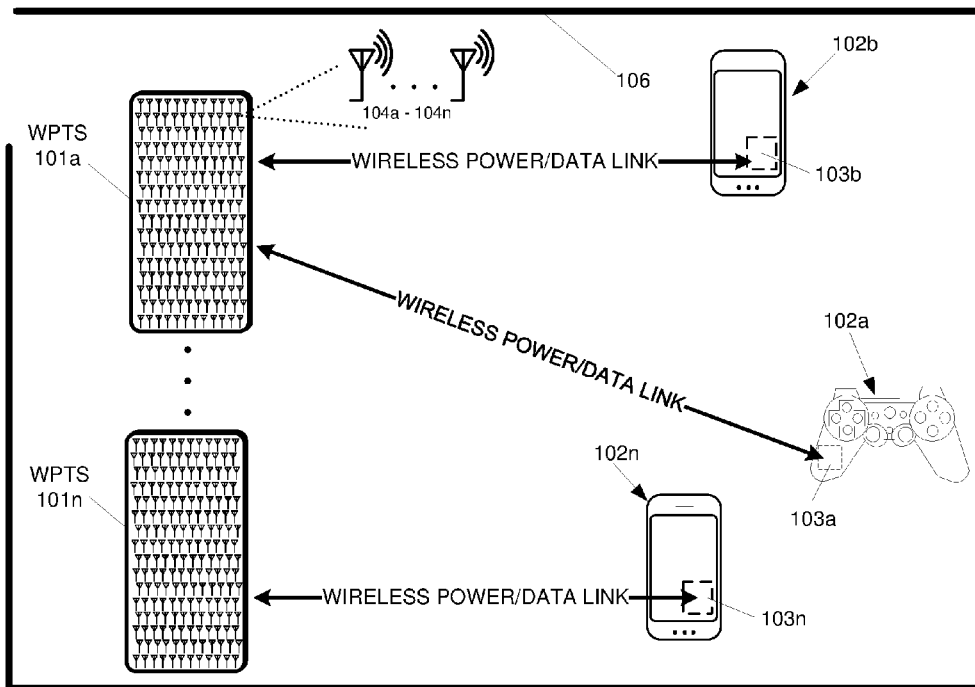

100 ↗

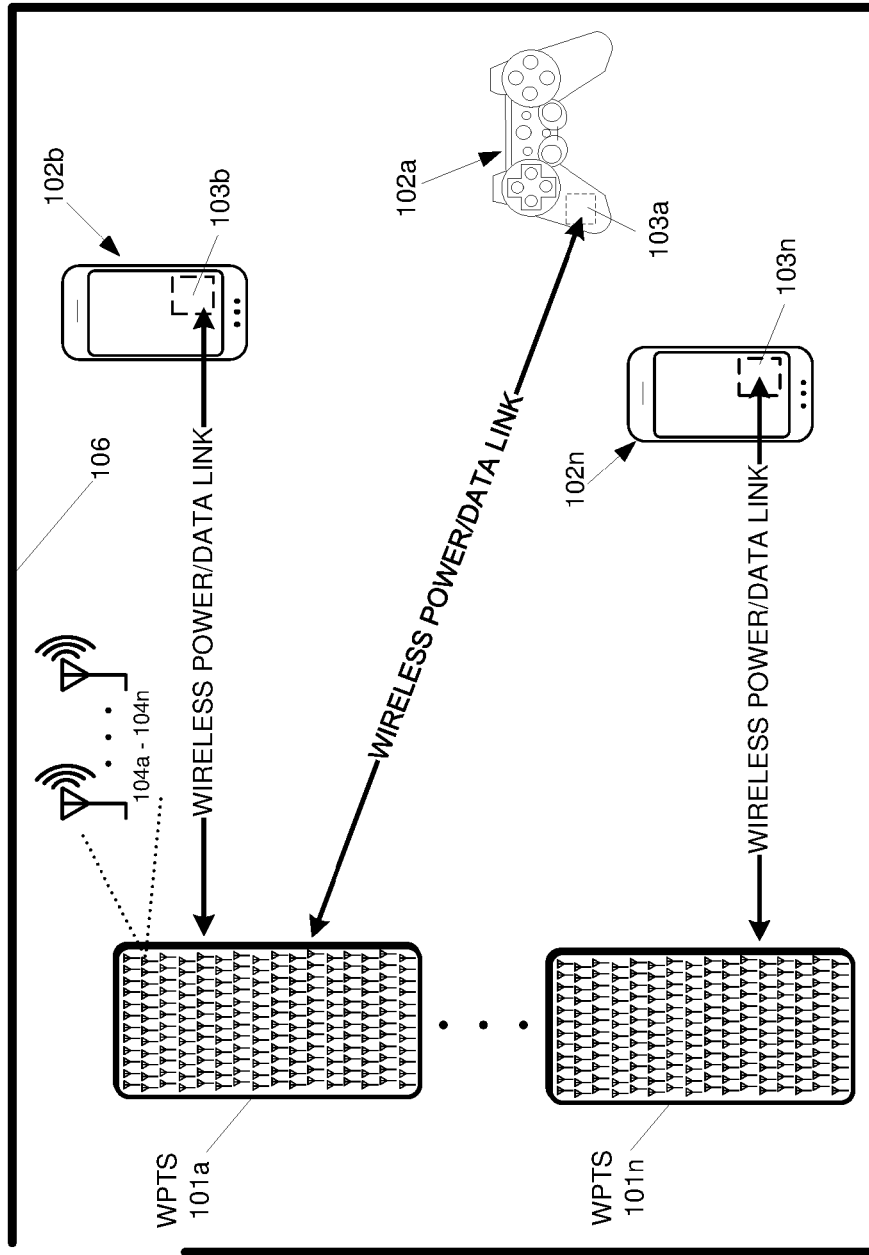

**FIG. 1**

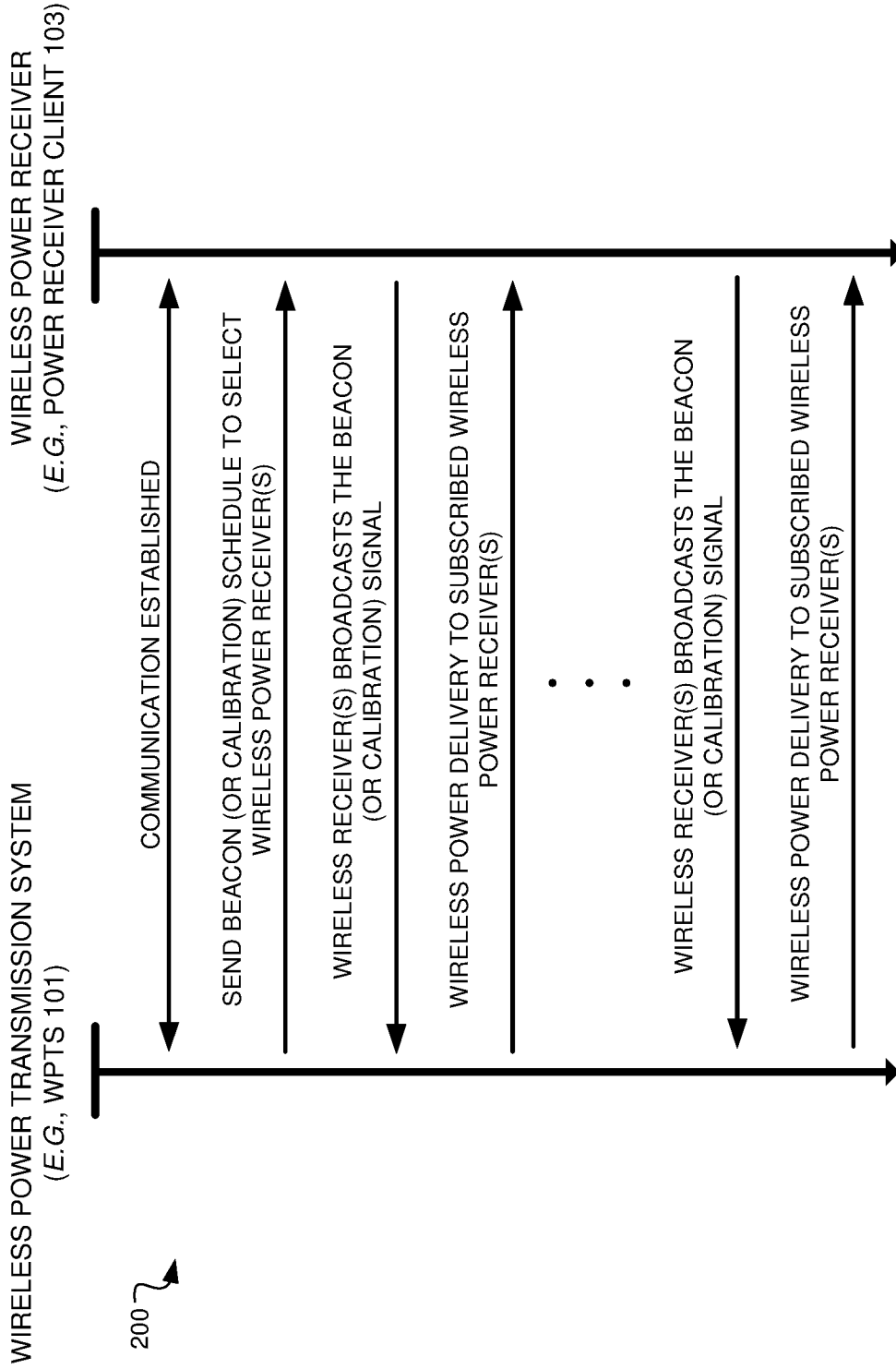

**FIG. 2**

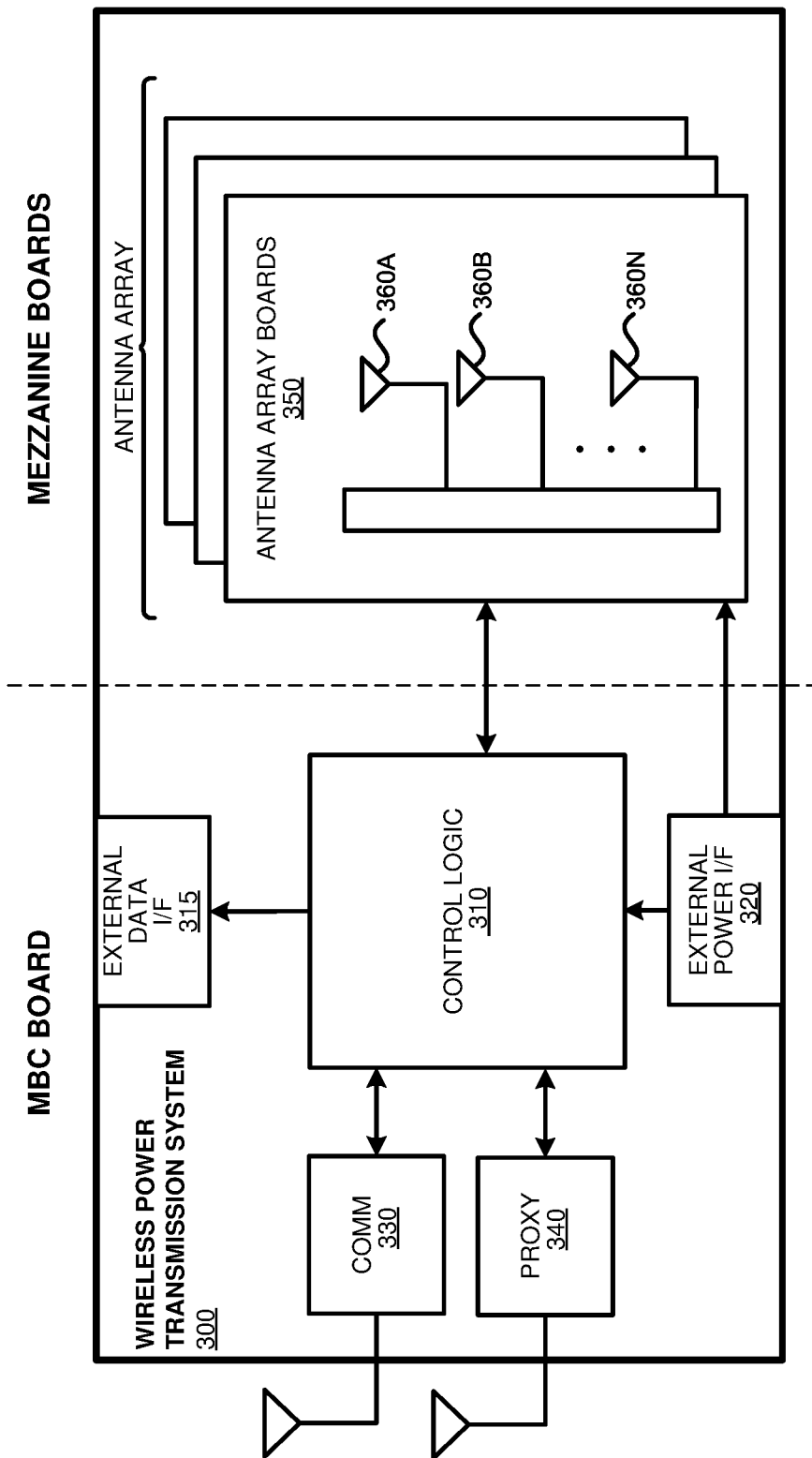

FIG. 3

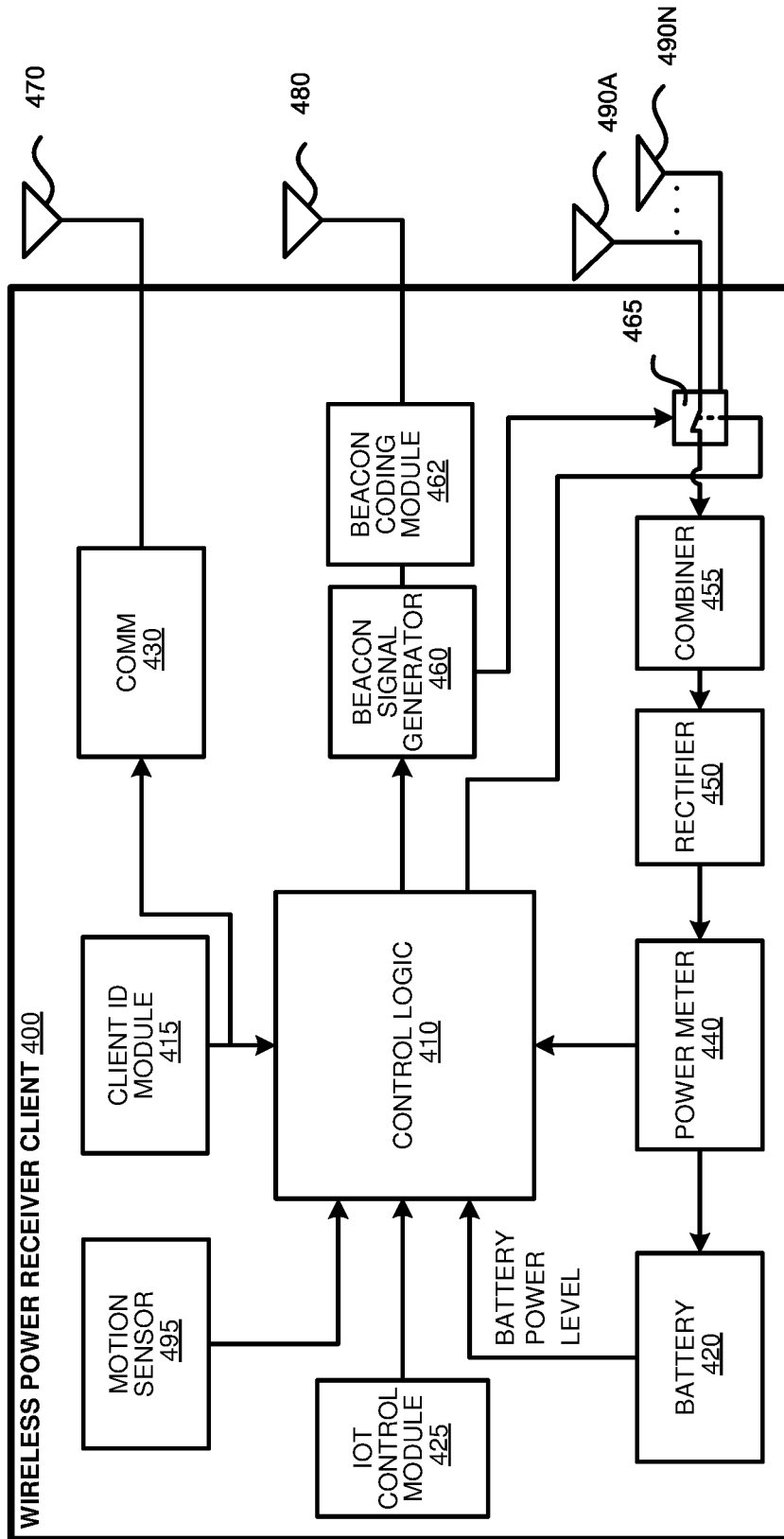

FIG. 4

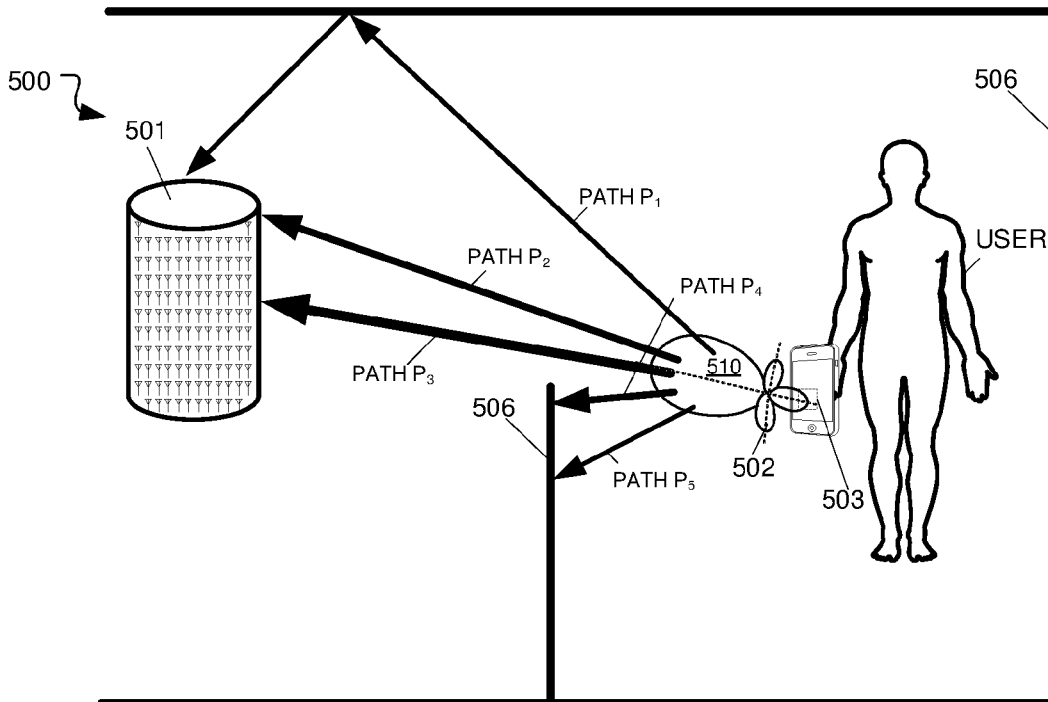

FIG. 5A

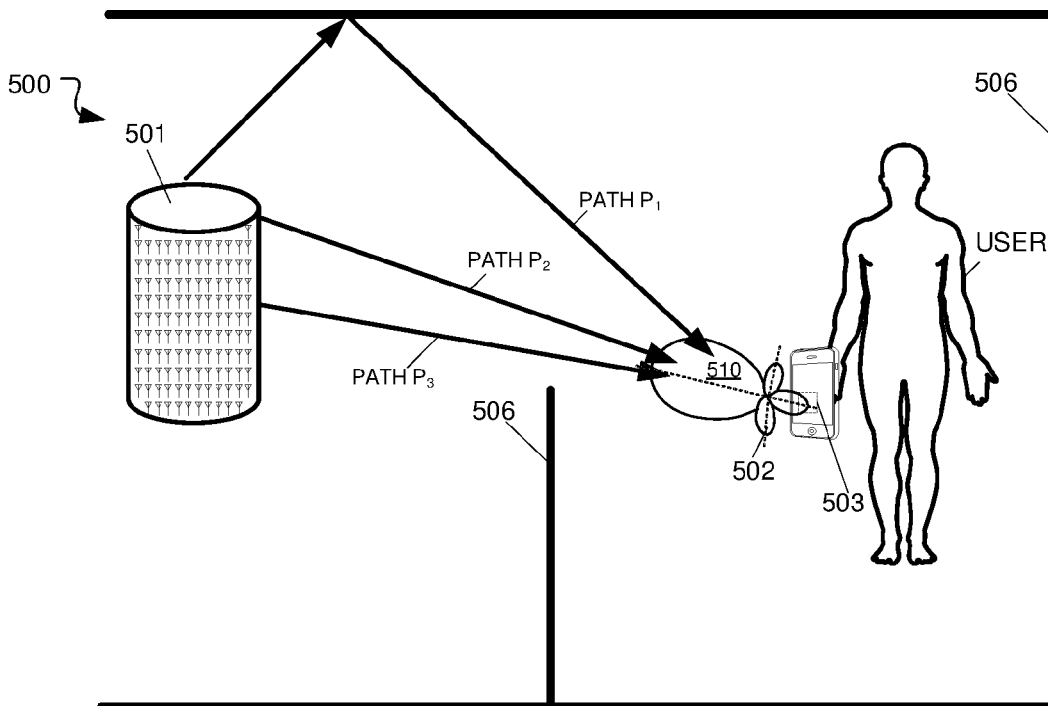

FIG. 5B

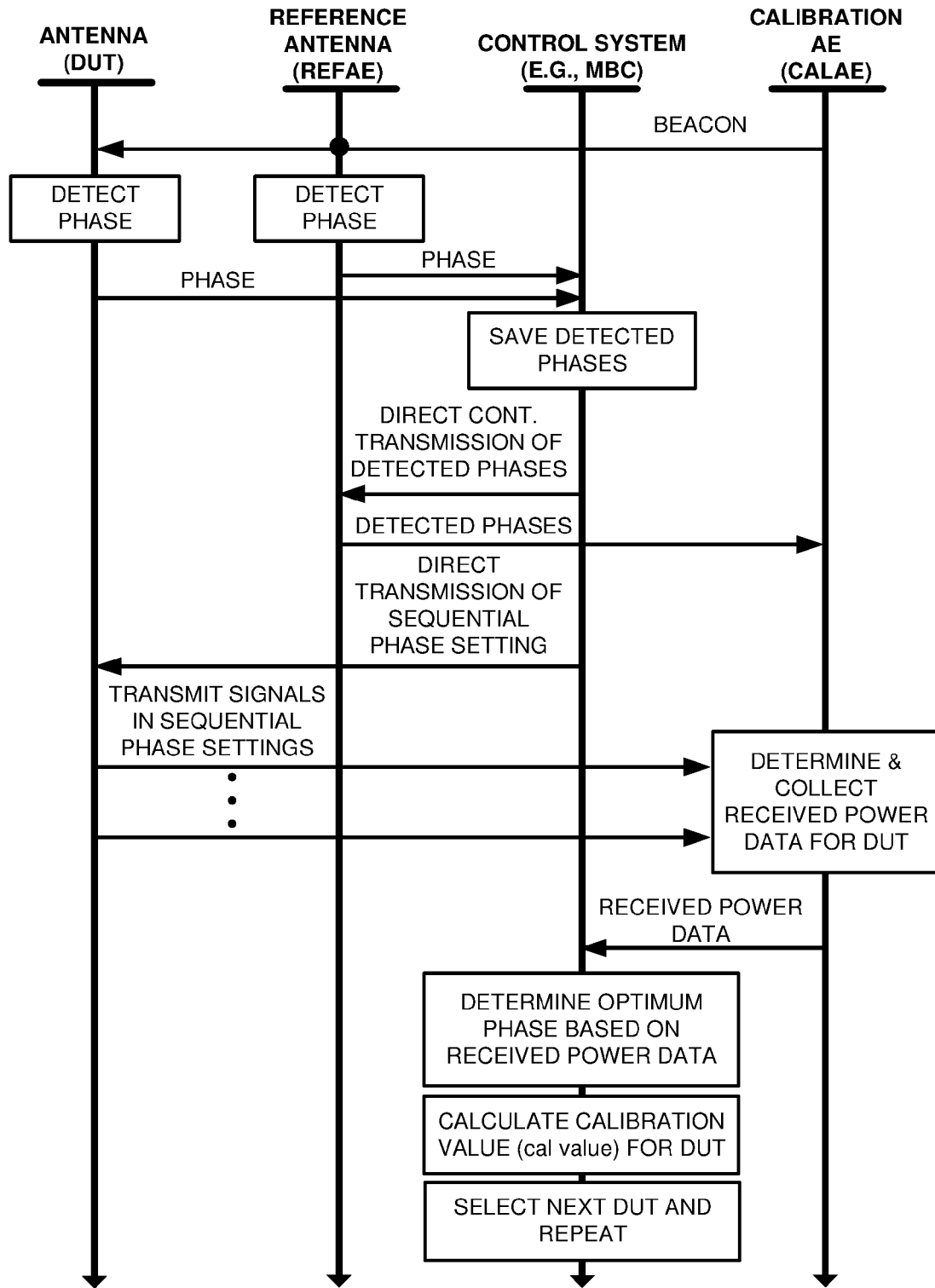

FIG. 6

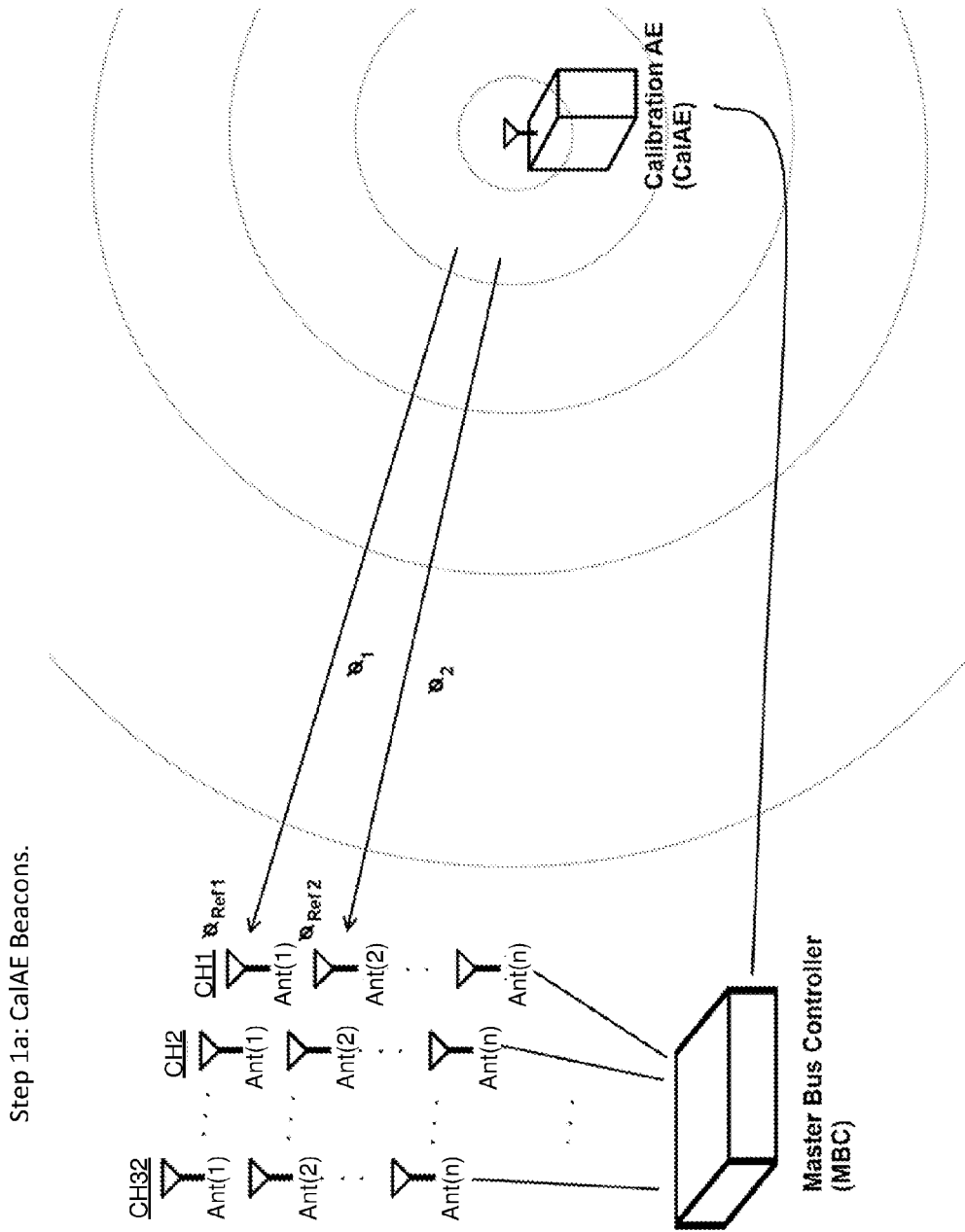

FIG. 7A



Step 1b: RefAE and DUT detect phase. Detected phases saved to MBC.

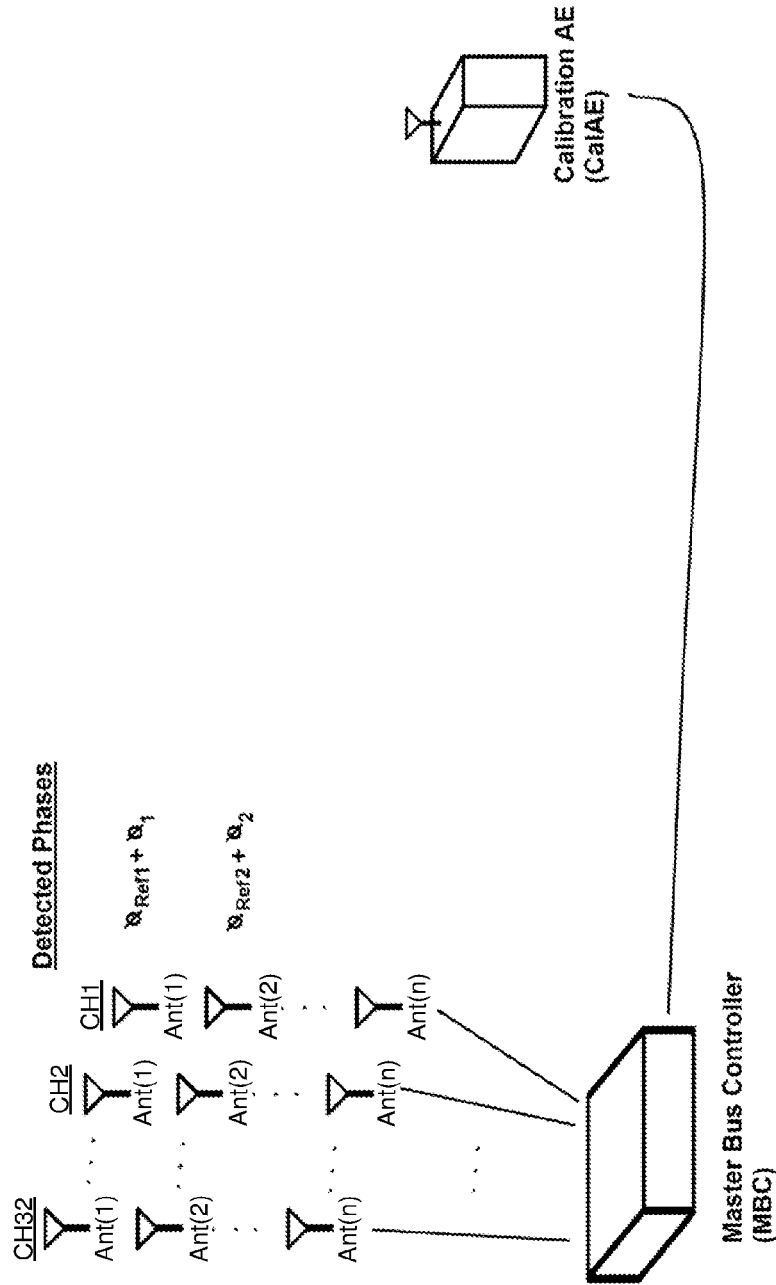

FIG. 7B

Steps 2-4: MBC commands RefAE to continuously transmit detected phase and DUT to transmit signals in sequential phase settings

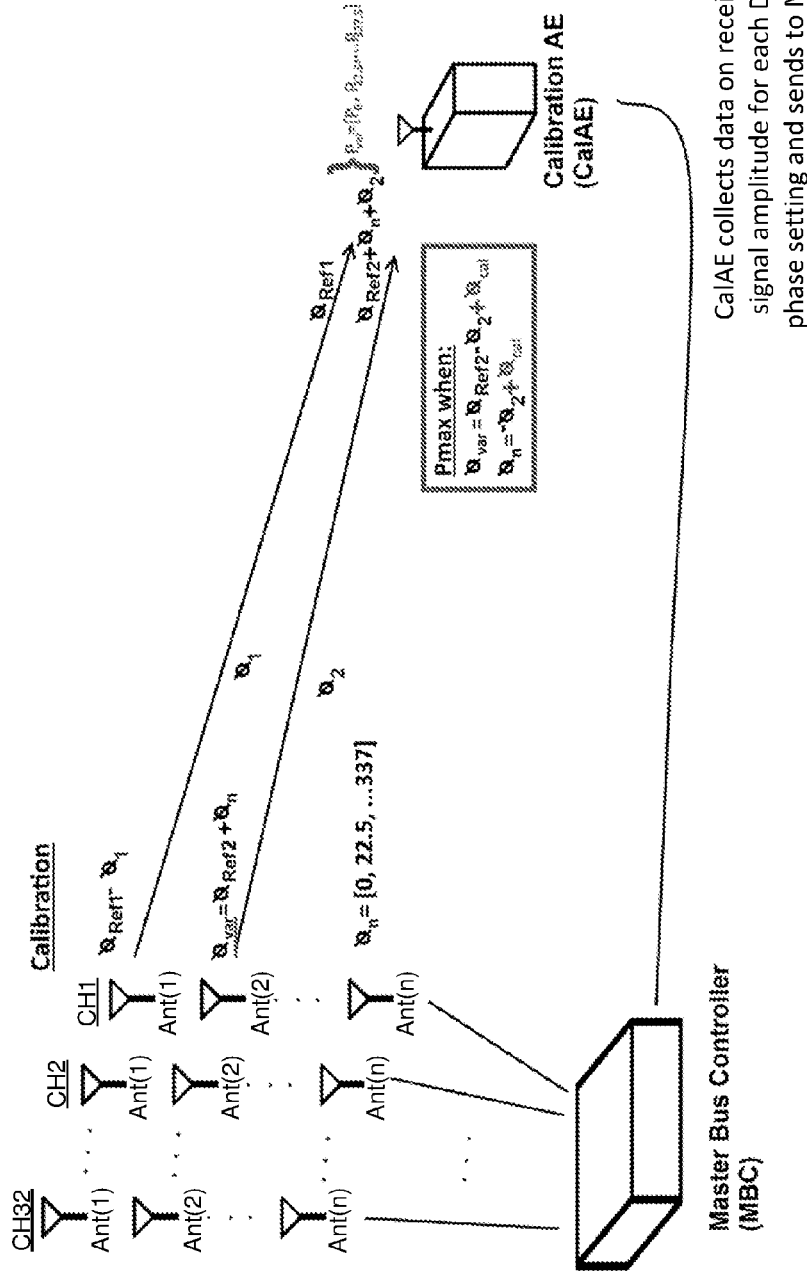

FIG. 7C

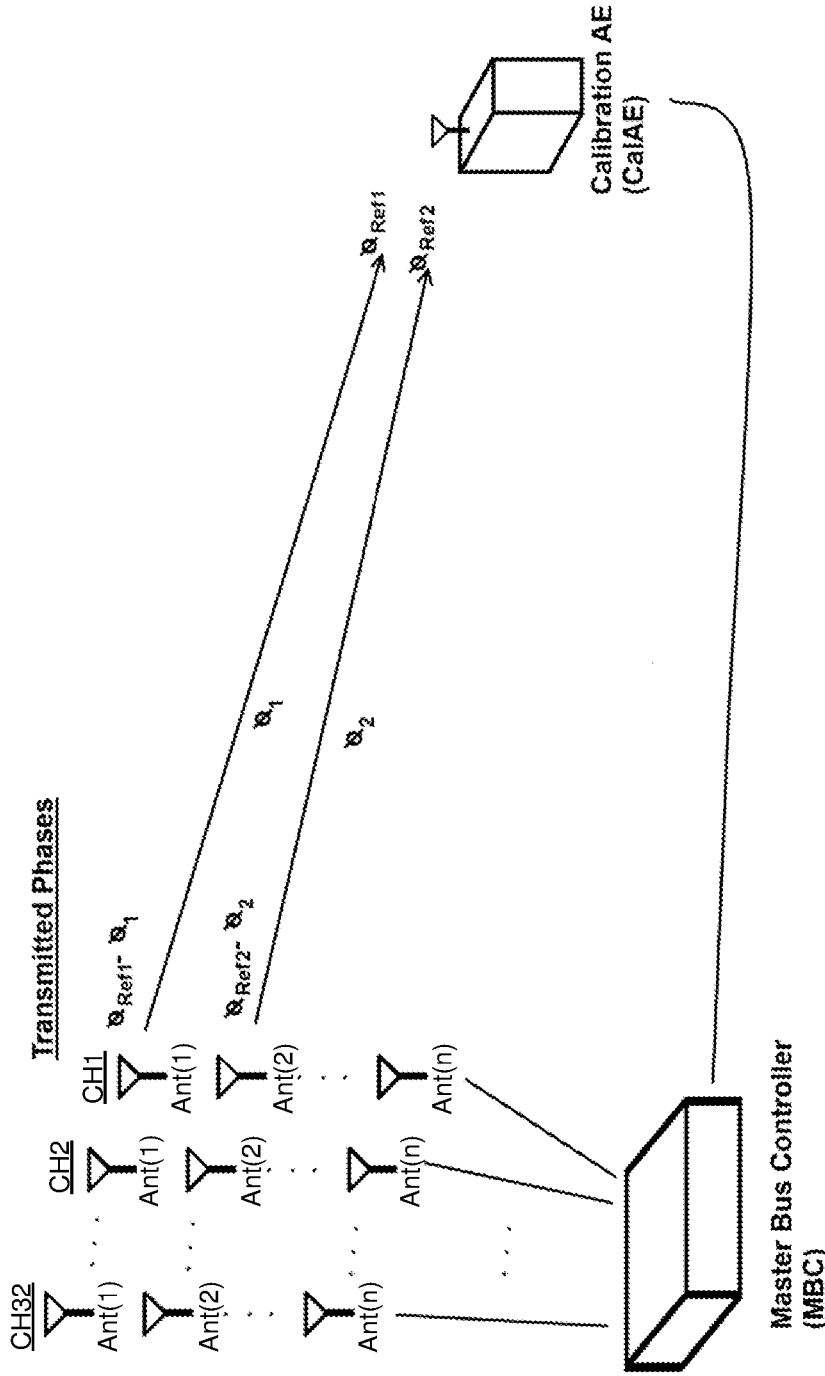

FIG. 8A

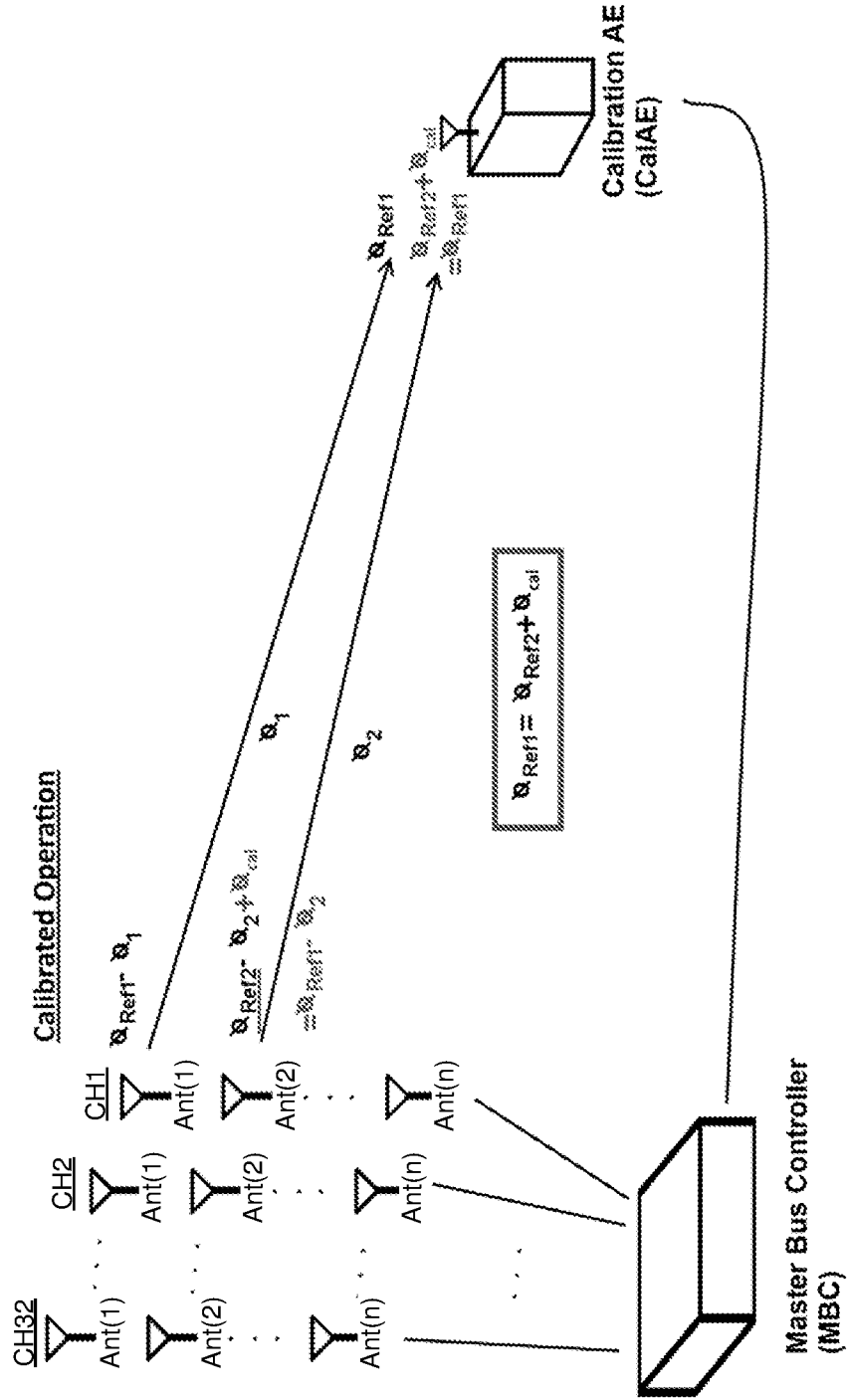
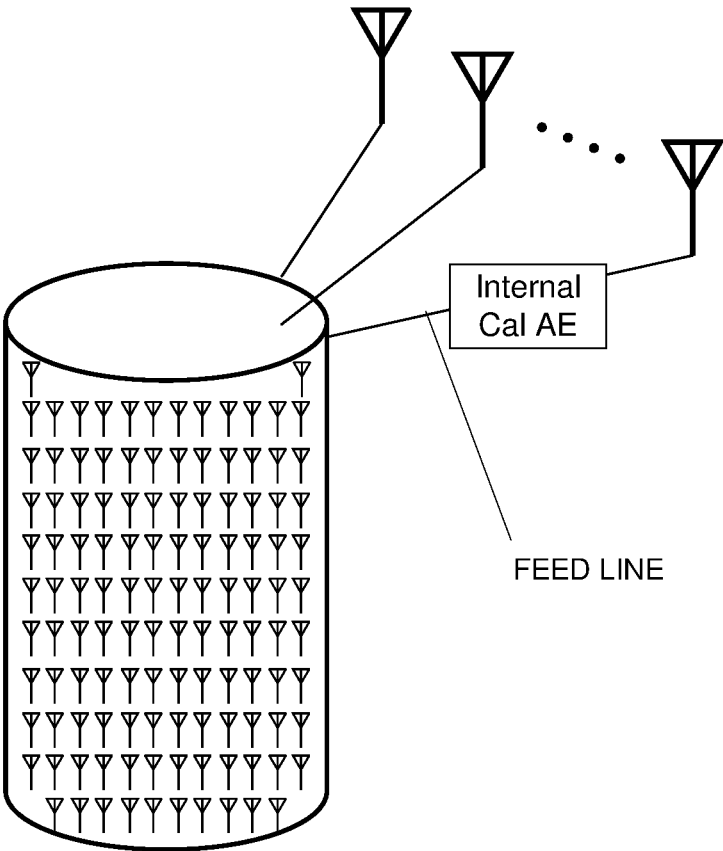

FIG. 8B



**FIG. 9**

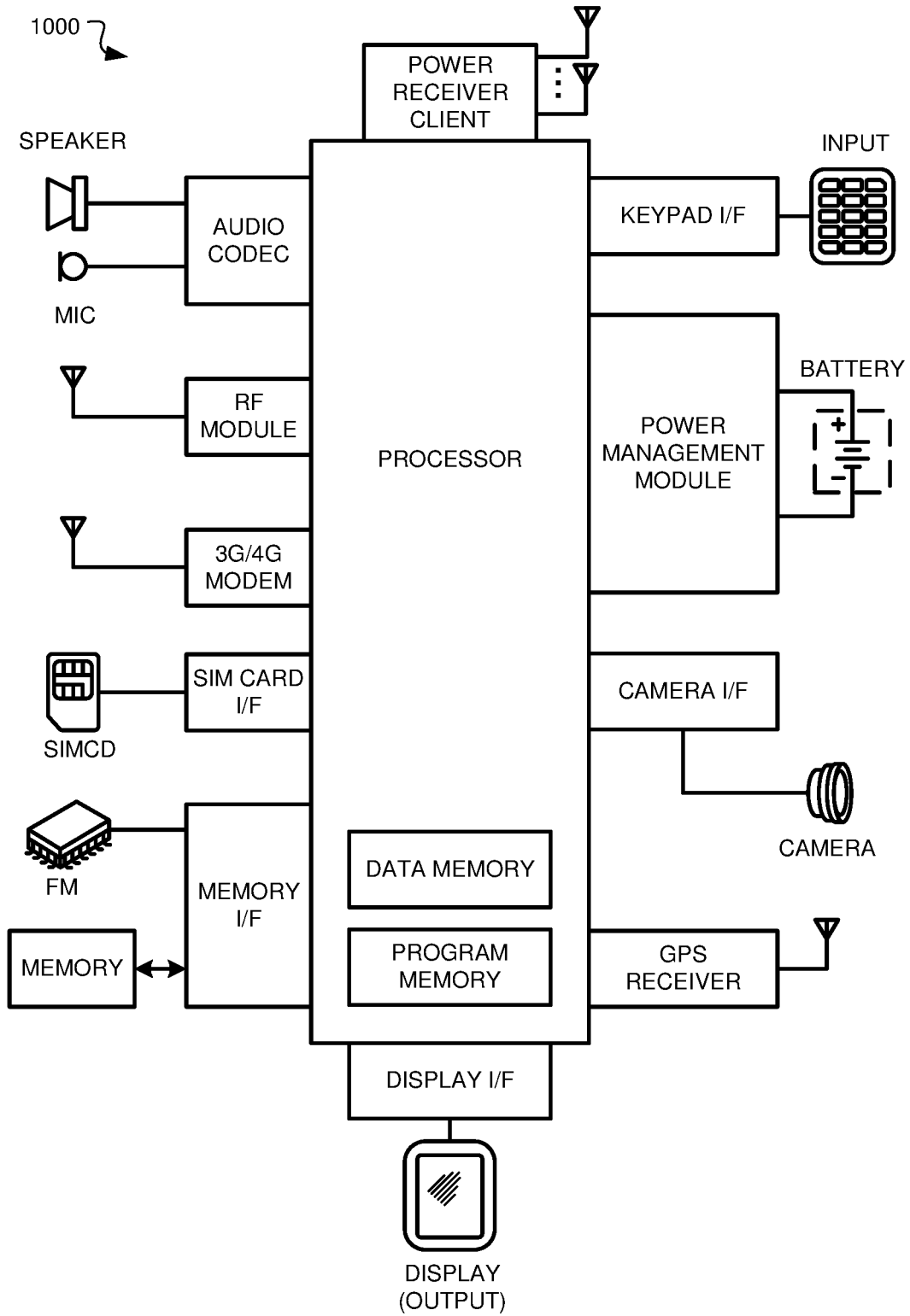

FIG. 10

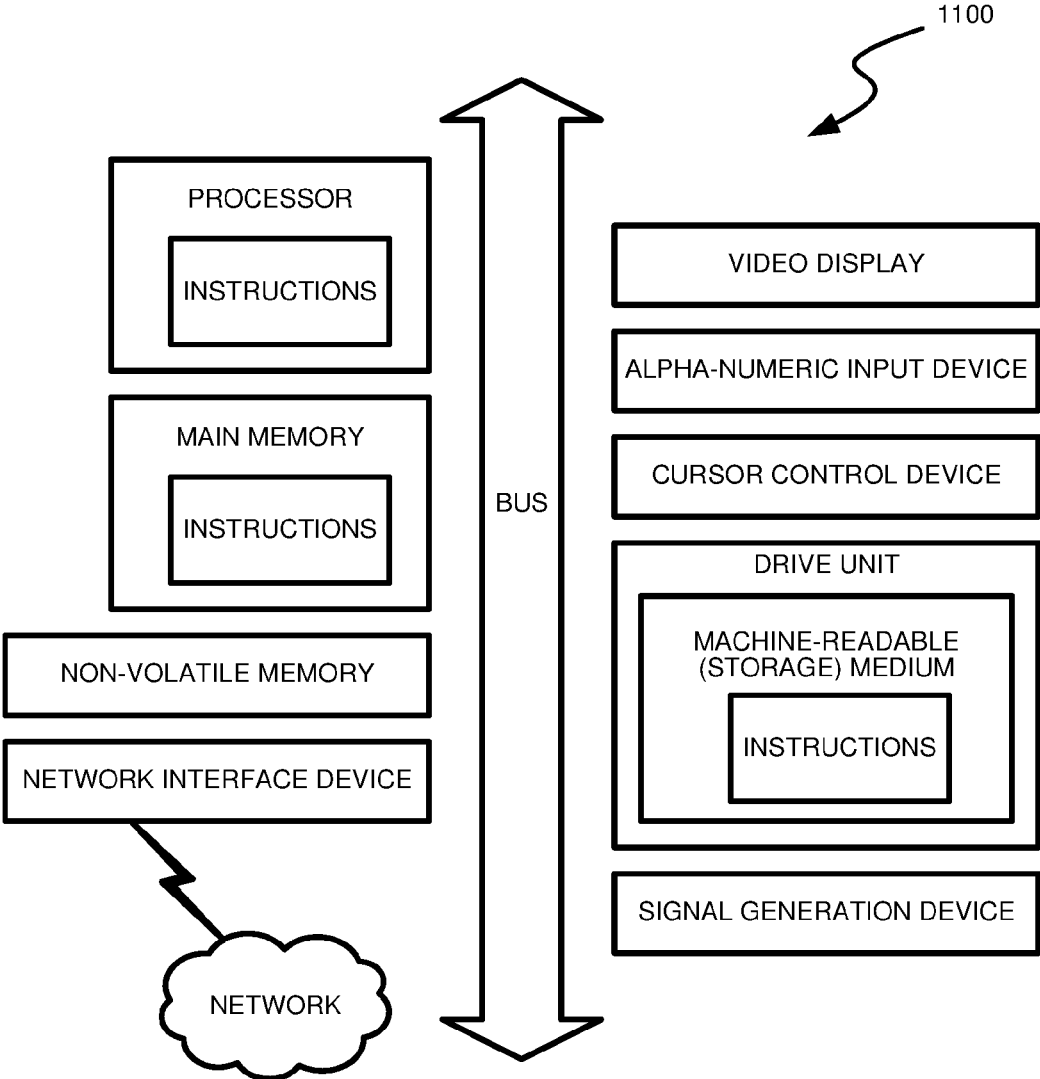

FIG. 11

**TECHNIQUES FOR CALIBRATING  
WIRELESS POWER TRANSMISSION  
SYSTEMS FOR OPERATION IN MULTIPATH  
WIRELESS POWER DELIVERY  
ENVIRONMENTS**

CROSS REFERENCE TO RELATED  
APPLICATIONS

**[0001]** This application claims priority to and benefit from U.S. Provisional Patent Application No. 62/337,147, filed on May 16, 2016, titled “TECHNIQUES FOR CALIBRATING WIRELESS POWER TRANSMISSION SYSTEMS FOR OPERATION IN MULTIPATH WIRELESS POWER DELIVERY ENVIRONMENTS,” which is expressly incorporated by reference herein.

TECHNICAL FIELD

**[0002]** The technology described herein relates generally to the field of wireless power transmission and, more specifically, to techniques for calibrating wireless power transmission systems in wireless power delivery environments.

BACKGROUND

**[0003]** Many electronic devices are powered by batteries. Rechargeable batteries are often used to avoid the cost of replacing conventional dry-cell batteries and to conserve precious resources. However, recharging batteries with conventional rechargeable battery chargers requires access to an alternating current (AC) power outlet, which is sometimes not available or not convenient. It is, therefore, desirable to derive power for electronics wirelessly.

**[0004]** Accordingly, a need exists for technology that overcomes the problem demonstrated above, as well as one that provides additional benefits. The examples provided herein of some prior or related systems and their associated limitations are intended to be illustrative and not exclusive. Other limitations of existing or prior systems will become apparent to those of skill in the art upon reading the following Detailed Description.

SUMMARY

**[0005]** Examples discussed herein relate to techniques for calibrating wireless power transmission systems (without an antenna in the far field) for operation in multipath wireless power delivery environments. In an implementation, a method of calibrating a wireless power transmission system for operation in a multipath environment is disclosed. The method includes characterizing a receive path from a calibration antennae element to a first antennae element of a plurality of antennae elements of the wireless power transmission system, characterizing a transmit path from the first antennae element to the calibration antennae element, and comparing the transmit path to the receive path to determine a calibration value for the first antennae element in the multipath environment.

**[0006]** This Overview is provided to introduce a selection of concepts in a simplified form that are further described below in the Technical Disclosure. It may be understood that this Overview is not intended to identify key features or essential features of the claimed subject matter, nor is it intended to be used to limit the scope of the claimed subject matter.

BRIEF DESCRIPTION OF THE DRAWINGS

**[0007]** One or more embodiments of the present invention are illustrated by way of example and not limitation in the figures of the accompanying drawings, in which like references indicate similar elements.

**[0008]** FIG. 1 depicts a block diagram including an example wireless power delivery environment illustrating wireless power delivery from one or more wireless power transmission systems to various wireless devices within the wireless power delivery environment in accordance with some embodiments.

**[0009]** FIG. 2 depicts a sequence diagram illustrating example operations between a wireless power transmission system and a wireless receiver client for commencing wireless power delivery in accordance with some embodiments.

**[0010]** FIG. 3 depicts a block diagram illustrating example components of a wireless power transmission system in accordance with some embodiments.

**[0011]** FIG. 4 depicts a block diagram illustrating example components of a wireless power receiver client in accordance with some embodiments.

**[0012]** FIGS. 5A and 5B depict diagrams illustrating an example multipath wireless power delivery environment in accordance with some embodiments.

**[0013]** FIG. 6 depicts a sequence diagram illustrating an example technique for calibrating a wireless power transmission system in a multipath wireless power delivery environment, according to some embodiments.

**[0014]** FIGS. 7A, 7B and 7C depict a system illustrating example technique for calibrating a wireless power transmission system in a multipath wireless power delivery environment, according to some embodiments.

**[0015]** FIG. 8A and 8B illustrate an example of uncalibrated system and a calibrated system, respectively, according to some embodiments.

**[0016]** FIG. 9 illustrates an example wireless power transmission system where the coupling across the feed lines to the antennas functions as a calibration antenna element (AE) within the enclosure of the wireless power transmission system (i.e., internal to the system-integrated calibration), according to some embodiments.

**[0017]** FIG. 10 depicts a block diagram illustrating example components of a representative mobile device or tablet computer with one or more wireless power receiver clients in the form of a mobile (or smart) phone or tablet computer device in accordance with some embodiments.

**[0018]** FIG. 11 depicts a diagrammatic representation of a machine, in the example form, of a computer system within which a set of instructions, for causing the machine to perform any one or more of the methodologies discussed herein, may be executed.

DETAILED DESCRIPTION

**[0019]** Techniques are described herein for calibrating wireless power transmission systems for operation in multipath wireless power delivery environments. Wireless power transmission can occur when multiple antennas of a wireless power transmission system focus energy over multiple paths to constructively interfere at a particular wireless power receiver (or client).

**[0020]** The following description and drawings are illustrative and are not to be construed as limiting. Numerous specific details are described to provide a thorough under-



standing of the disclosure. However, in certain instances, well-known or conventional details are not described in order to avoid obscuring the description. References to one or an embodiment in the present disclosure can be, but not necessarily are, references to the same embodiment; and, such references mean at least one of the embodiments.

[0021] Reference in this specification to “one embodiment” or “an embodiment” means that a particular feature, structure, or characteristic described in connection with the embodiment is included in at least one embodiment of the disclosure. The appearances of the phrase “in one embodiment” in various places in the specification are not necessarily all referring to the same embodiment, nor are separate or alternative embodiments mutually exclusive of other embodiments. Moreover, various features are described which may be exhibited by some embodiments and not by others. Similarly, various requirements are described which may be requirements for some embodiments but no other embodiments.

[0022] The terms used in this specification generally have their ordinary meanings in the art, within the context of the disclosure, and in the specific context where each term is used. Certain terms that are used to describe the disclosure are discussed below, or elsewhere in the specification, to provide additional guidance to the practitioner regarding the description of the disclosure. For convenience, certain terms may be highlighted, for example using italics and/or quotation marks. The use of highlighting has no influence on the scope and meaning of a term; the scope and meaning of a term is the same, in the same context, whether or not it is highlighted. It will be appreciated that same thing can be said in more than one way.

[0023] Consequently, alternative language and synonyms may be used for any one or more of the terms discussed herein, nor is any special significance to be placed upon whether or not a term is elaborated or discussed herein. Synonyms for certain terms are provided. A recital of one or more synonyms does not exclude the use of other synonyms. The use of examples anywhere in this specification, including examples of any terms discussed herein, is illustrative only, and is not intended to further limit the scope and meaning of the disclosure or of any exemplified term. Likewise, the disclosure is not limited to various embodiments given in this specification.

[0024] Without intent to further limit the scope of the disclosure, examples of instruments, apparatus, methods and their related results according to the embodiments of the present disclosure are given below. Note that titles or subtitles may be used in the examples for convenience of a reader, which in no way should limit the scope of the disclosure. Unless otherwise defined, all technical and scientific terms used herein have the same meaning as commonly understood by one of ordinary skill in the art to which this disclosure pertains. In the case of conflict, the present document, including definitions, will control.

[0025] Any headings provided herein are for convenience only and do not necessarily affect the scope or meaning of the claimed invention.

### I. Wireless Power Transmission System Overview/Architecture

[0026] FIG. 1 depicts a block diagram including an example wireless power delivery environment 100 illustrating wireless power delivery from one or more wireless

power transmission systems (WPTS) 101a-n (also referred to as “wireless power delivery systems”, “antenna array systems” and “wireless chargers”) to various wireless devices 102a-n within the wireless power delivery environment 100, according to some embodiments. More specifically, FIG. 1 illustrates an example wireless power delivery environment 100 in which wireless power and/or data can be delivered to available wireless devices 102a-102n having one or more wireless power receiver clients 103a-103n (also referred to herein as “clients” and “wireless power receivers”). The wireless power receiver clients are configured to receive and process wireless power from one or more wireless power transmission systems 101a-101n. Components of an example wireless power receiver client 103 are shown and discussed in greater detail with reference to FIG. 4.

[0027] As shown in the example of FIG. 1, the wireless devices 102a-102n include mobile phone devices and a wireless game controller. However, the wireless devices 102a-102n can be any device or system that needs power and is capable of receiving wireless power via one or more integrated wireless power receiver clients 103a-103n. As discussed herein, the one or more integrated wireless power receiver clients receive and process power from one or more wireless power transmission systems 101a-101n and provide the power to the wireless devices 102a-102n (or internal batteries of the wireless devices) for operation thereof.

[0028] Each wireless power transmission system 101 can include multiple antennas 104a-n, e.g., an antenna array including hundreds or thousands of antennas, which are capable of delivering wireless power to wireless devices 102a-102n. In some embodiments, the antennas are adaptively-phased RF antennas. The wireless power transmission system 101 is capable of determining the appropriate phases with which to deliver a coherent power transmission signal to the wireless power receiver clients 103a-103n. The array is configured to emit a signal (e.g., continuous wave or pulsed power transmission signal) from multiple antennas at a specific phase relative to each other. It is appreciated that use of the term “array” does not necessarily limit the antenna array to any specific array structure. That is, the antenna array does not need to be structured in a specific “array” form or geometry. Furthermore, as used herein the term “array” or “array system” may include related and peripheral circuitry for signal generation, reception and transmission, such as radios, digital logic and modems. In some embodiments, the wireless power transmission system 101 can have an embedded Wi-Fi hub for data communications via one or more antennas or transceivers.

[0029] The wireless devices 102 can include one or more wireless power receiver clients 103. As illustrated in the example of FIG. 1, power delivery antennas 104a-104n are shown. The power delivery antennas 104a are configured to provide delivery of wireless radio frequency power in the wireless power delivery environment. In some embodiments, one or more of the power delivery antennas 104a-104n can alternatively or additionally be configured for data communications in addition to or in lieu of wireless power delivery. The one or more data communication antennas are configured to send data communications to and receive data communications from the wireless power receiver clients 103a-103n and/or the wireless devices 102a-102n. In some embodiments, the data communication antennas can com-

municate via Bluetooth™, Wi-Fi™, ZigBee™, etc. Other data communication protocols are also possible.

[0030] Each wireless power receiver client **103a-103n** includes one or more antennas (not shown) for receiving signals from the wireless power transmission systems **101a-101n**. Likewise, each wireless power transmission system **101a-101n** includes an antenna array having one or more antennas and/or sets of antennas capable of emitting continuous wave or discrete (pulse) signals at specific phases relative to each other. As discussed above, each the wireless power transmission systems **101a-101n** is capable of determining the appropriate phases for delivering the coherent signals to the wireless power receiver clients **102a-102n**. For example, in some embodiments, coherent signals can be determined by computing the complex conjugate of a received beacon (or calibration) signal at each antenna of the array such that the coherent signal is phased for delivering power to the particular wireless power receiver client that transmitted the beacon (or calibration) signal.

[0031] Although not illustrated, each component of the environment, e.g., wireless device, wireless power transmission system, etc., can include control and synchronization mechanisms, e.g., a data communication synchronization module. The wireless power transmission systems **101a-101n** can be connected to a power source such as, for example, a power outlet or source connecting the wireless power transmission systems to a standard or primary AC power supply in a building. Alternatively, or additionally, one or more of the wireless power transmission systems **101a-101n** can be powered by a battery or via other mechanisms, e.g., solar cells, etc.

[0032] The wireless power receiver clients **102a-102n** and/or the wireless power transmission systems **101a-101n** are configured to operate in a multipath wireless power delivery environment. That is, the wireless power receiver clients **102a-102n** and the wireless power transmission systems **101a-101n** are configured to utilize reflective objects **106** such as, for example, walls or other RF reflective obstructions within range to transmit beacon (or calibration) signals and/or receive wireless power and/or data within the wireless power delivery environment. The reflective objects **106** can be utilized for multi-directional signal communication regardless of whether a blocking object is in the line of sight between the wireless power transmission system and the wireless power receiver clients **103a-103n**.

[0033] As described herein, each wireless device **102a-102n** can be any system and/or device, and/or any combination of devices/systems that can establish a connection with another device, a server and/or other systems within the example environment **100**. In some embodiments, the wireless devices **102a-102n** include displays or other output functionalities to present data to a user and/or input functionalities to receive data from the user. By way of example, a wireless device **102** can be, but is not limited to, a video game controller, a server desktop, a desktop computer, a computer cluster, a mobile computing device such as a notebook, a laptop computer, a handheld computer, a mobile phone, a smart phone, a PDA, a Blackberry device, a Treo, and/or an iPhone, etc. By way of example and not limitation, the wireless device **102** can also be any wearable device such as watches, necklaces, rings or even devices embedded on or within the customer. Other examples of a wireless device **102** include, but are not limited to, safety sensors

(e.g., fire or carbon monoxide), electric toothbrushes, electronic door lock/handles, electric light switch controller, electric shavers, etc.

[0034] Although not illustrated in the example of FIG. 1, the wireless power transmission system **101** and the wireless power receiver clients **103a-103n** can each include a data communication module for communication via a data channel. Alternatively, or additionally, the wireless power receiver clients **103a-103n** can direct the wireless devices **102a-102n** to communicate with the wireless power transmission system via existing data communications modules. In some embodiments the beacon signal, which is primarily referred to herein as a continuous waveform, can alternatively or additionally take the form of a modulated signal.

[0035] FIG. 2 depicts a sequence diagram **200** illustrating example operations between a wireless power delivery system (e.g., WPTS **101**) and a wireless power receiver client (e.g., wireless power receiver client **103**) for establishing wireless power delivery in a multipath wireless power delivery, according to an embodiment. Initially, communication is established between the wireless power transmission system **101** and the power receiver client **103**. The initial communication can be, for example, a data communication link that is established via one or more antennas **104** of the wireless power transmission system **101**. As discussed, in some embodiments, one or more of the antennas **104a-104n** can be data antennas, wireless power transmission antennas, or dual-purpose data/power antennas. Various information can be exchanged between the wireless power transmission system **101** and the wireless power receiver client **103** over this data communication channel. For example, wireless power signaling can be time sliced among various clients in a wireless power delivery environment. In such cases, the wireless power transmission system **101** can send beacon schedule information, e.g., Beacon Beat Schedule (BBS) cycle, power cycle information, etc., so that the wireless power receiver client **103** knows when to transmit (broadcast) its beacon signals and when to listen for power, etc.

[0036] Continuing with the example of FIG. 2, the wireless power transmission system **101** selects one or more wireless power receiver clients for receiving power and sends the beacon schedule information to the select wireless power receiver clients **103**. The wireless power transmission system **101** can also send power transmission scheduling information so that the wireless power receiver client **103** knows when to expect (e.g., a window of time) wireless power from the wireless power transmission system. The wireless power receiver client **103** then generates a beacon (or calibration) signal and broadcasts the beacon during an assigned beacon transmission window (or time slice) indicated by the beacon schedule information, e.g., BBS cycle. As discussed herein, the wireless power receiver client **103** includes one or more antennas (or transceivers) which have a radiation and reception pattern in three-dimensional space proximate to the wireless device **102** in which the wireless power receiver client **103** is embedded.

[0037] The wireless power transmission system **101** receives the beacon from the power receiver client **103** and detects and/or otherwise measures the phase (or direction) from which the beacon signal is received at multiple antennas. The wireless power transmission system **101** then delivers wireless power to the power receiver client **103** from the multiple antennas **103** based on the detected or

measured phase (or direction) of the received beacon at each of the corresponding antennas. In some embodiments, the wireless power transmission system 101 determines the complex conjugate of the measured phase of the beacon and uses the complex conjugate to determine a transmit phase that configures the antennas for delivering and/or otherwise directing wireless power to the wireless power receiver client 103 via the same path over which the beacon signal was received from the wireless power receiver client 103.

**[0038]** In some embodiments, the wireless power transmission system 101 includes many antennas. One or more of the many antennas may be used to deliver power to the power receiver client 103. The wireless power transmission system 101 can detect and/or otherwise determine or measure phases at which the beacon signals are received at each antenna. The large number of antennas may result in different phases of the beacon signal being received at each antenna of the wireless power transmission system 101. As discussed above, the wireless power transmission system 101 can determine the complex conjugate of the beacon signals received at each antenna. Using the complex conjugates, one or more antennas may emit a signal that takes into account the effects of the large number of antennas in the wireless power transmission system 101. In other words, the wireless power transmission system 101 can emit a wireless power transmission signal from the one or more antennas in such a way as to create an aggregate signal from the one or more of the antennas that approximately recreates the waveform of the beacon in the opposite direction. Said another way, the wireless power transmission system 101 can deliver wireless RF power to the wireless power receiver clients via the same paths over which the beacon signal is received at the wireless power transmission system 101. These paths can utilize reflective objects 106 within the environment. Additionally, the wireless power transmission signals can be simultaneously transmitted from the wireless power transmission system 101 such that the wireless power transmission signals collectively match the antenna radiation and reception pattern of the client device in a three-dimensional (3D) space proximate to the client device.

**[0039]** As shown, the beacon (or calibration) signals can be periodically transmitted by wireless power receiver clients 103 within the power delivery environment according to, for example, the BBS, so that the wireless power transmission system 101 can maintain knowledge and/or otherwise track the location of the power receiver clients 103 in the wireless power delivery environment. The process of receiving beacon signals from a wireless power receiver client 103 at the wireless power transmission system and, in turn, responding with wireless power directed to that particular wireless power receiver client is referred to herein as retrodirective wireless power delivery.

**[0040]** Furthermore, as discussed herein, wireless power can be delivered in power cycles defined by power schedule information. A more detailed example of the signaling required to commence wireless power delivery is described now with reference to FIG. 3.

**[0041]** FIG. 3 depicts a block diagram illustrating example components of a wireless power transmission system 300, in accordance with an embodiment. As illustrated in the example of FIG. 3, the wireless charger 300 includes a master bus controller (MBC) board and multiple mezzanine boards that collectively comprise the antenna array. The MBC includes control logic 310, an external data interface

(I/F) 315, an external power interface (I/F) 320, a communication block 330 and proxy 340. The mezzanine (or antenna array boards 350) each include multiple antennas 360a-360n. Some or all of the components can be omitted in some embodiments. Additional components are also possible. For example, in some embodiments only one of communication block 330 or proxy 340 may be included.

**[0042]** The control logic 310 is configured to provide control and intelligence to the array components. The control logic 310 may comprise one or more processors, FPGAs, memory units, etc., and direct and control the various data and power communications. The communication block 330 can direct data communications on a data carrier frequency, such as the base signal clock for clock synchronization. The data communications can be Bluetooth™, Wi-Fi™, ZigBee™, etc., including combinations or variations thereof. Likewise, the proxy 340 can communicate with clients via data communications as discussed herein. The data communications can be, by way of example and not limitation, Bluetooth™, Wi-Fi™, ZigBee™, etc. Other communication protocols are possible.

**[0043]** In some embodiments, the control logic 310 can also facilitate and/or otherwise enable data aggregation for Internet of Things (IoT) devices. In some embodiments, wireless power receiver clients can access, track and/or otherwise obtain IoT information about the device in which the wireless power receiver client is embedded and provide that IoT information to the wireless power transmission system 300 over a data connection. This IoT information can be provided to via an external data interface 315 to a central or cloud-based system (not shown) where the data can be aggregated, processed, etc. For example, the central system can process the data to identify various trends across geographies, wireless power transmission systems, environments, devices, etc. In some embodiments, the aggregated data and or the trend data can be used to improve operation of the devices via remote updates, etc. Alternatively, or additionally, in some embodiments, the aggregated data can be provided to third party data consumers. In this manner, the wireless power transmission system acts as a Gateway or Enabler for the IoTs. By way of example and not limitation, the IoT information can include capabilities of the device in which the wireless power receiver client is embedded, usage information of the device, power levels of the device, information obtained by the device or the wireless power receiver client itself, e.g., via sensors, etc.

**[0044]** The external power interface 320 is configured to receive external power and provide the power to various components. In some embodiments, the external power interface 320 may be configured to receive a standard external 24 Volt power supply. In other embodiments, the external power interface 320 can be, for example, 120/240 Volt AC mains to an embedded DC power supply which sources the required 12/24/48 Volt DC to provide the power to various components. Alternatively, the external power interface could be a DC supply which sources the required 12/24/48 Volts DC. Alternative configurations are also possible.

**[0045]** In operation, the MBC, which controls the wireless power transmission system 300, receives power from a power source and is activated. The MBC then activates the proxy antenna elements on the wireless power transmission system and the proxy antenna elements enter a default “discovery” mode to identify available wireless receiver

clients within range of the wireless power transmission system. When a client is found, the antenna elements on the wireless power transmission system power on, enumerate, and (optionally) calibrate.

[0046] The MBC then generates beacon transmission scheduling information and power transmission scheduling information during a scheduling process. The scheduling process includes selection of power receiver clients. For example, the MBC can select power receiver clients for power transmission and generate a BBS cycle and a Power Schedule (PS) for the selected wireless power receiver clients. As discussed herein, the power receiver clients can be selected based on their corresponding properties and/or requirements.

[0047] In some embodiments, the MBC can also identify and/or otherwise select available clients that will have their status queried in the Client Query Table (CQT). Clients that are placed in the CQT are those on “standby”, e.g., not receiving a charge. The BBS and PS are calculated based on vital information about the clients such as, for example, battery status, current activity/usage, how much longer the client has until it runs out of power, priority in terms of usage, etc.

[0048] The Proxy Antenna Element (AE) broadcasts the BBS to all clients. As discussed herein, the BBS indicates when each client should send a beacon. Likewise, the PS indicates when and to which clients the array should send power to and when clients should listen for wireless power. Each client starts broadcasting its beacon and receiving power from the array per the BBS and PS. The Proxy AE can concurrently query the Client Query Table to check the status of other available clients. In some embodiments, a client can only exist in the BBS or the CQT (e.g., waitlist), but not in both. The information collected in the previous step continuously and/or periodically updates the BBS cycle and/or the PS.

[0049] FIG. 4 is a block diagram illustrating example components of a wireless power receiver client 400, in accordance with some embodiments. As illustrated in the example of FIG. 4, the receiver 400 includes control logic 410, battery 420, an IoT control module 425, communication block 430 and associated antenna 470, power meter 440, rectifier 450, a combiner 455, beacon signal generator 460, beacon coding unit 462 and an associated antenna 480, and switch 465 connecting the rectifier 450 or the beacon signal generator 460 to one or more associated antennas 490a-n. Some or all of the components can be omitted in some embodiments. For example, in some embodiments, the wireless power receiver client 400 does not include its own antennas but instead utilizes and/or otherwise shares one or more antennas (e.g., Wi-Fi antenna) of the wireless device in which the wireless power receiver client is embedded. Moreover, in some embodiments, the wireless power receiver client may include a single antenna that provides data transmission functionality as well as power/data reception functionality. Additional components are also possible.

[0050] A combiner 455 receives and combines the received power transmission signals from the power transmitter in the event that the receiver 400 has more than one antenna. The combiner can be any combiner or divider circuit that is configured to achieve isolation between the output ports while maintaining a matched condition. For example, the combiner 455 can be a Wilkinson Power Divider circuit. The rectifier 450 receives the combined

power transmission signal from the combiner 455, if present, which is fed through the power meter 440 to the battery 420 for charging. In other embodiments, each antenna's power path can have its own rectifier 450 and the DC power out of the rectifiers is combined prior to feeding the power meter 440. The power meter 440 can measure the received power signal strength and provides the control logic 410 with this measurement.

[0051] Battery 420 can include protection circuitry and/or monitoring functions. Additionally, the battery 420 can include one or more features, including, but not limited to, current limiting, temperature protection, over/under voltage alerts and protection, and coulomb monitoring.

[0052] The control logic 410 receives and processes the battery power level from the battery 420 itself. The control logic 410 may also transmit/receive via the communication block 430 a data signal on a data carrier frequency, such as the base signal clock for clock synchronization. The beacon signal generator 460 generates the beacon signal, or calibration signal, transmits the beacon signal using either the antenna 480 or 490 after the beacon signal is encoded.

[0053] It may be noted that, although the battery 420 is shown as charged by, and providing power to, the wireless power receiver client 400, the receiver may also receive its power directly from the rectifier 450. This may be in addition to the rectifier 450 providing charging current to the battery 420, or in lieu of providing charging. Also, it may be noted that the use of multiple antennas is one example of implementation and the structure may be reduced to one shared antenna.

[0054] In some embodiments, the control logic 410 and/or the IoT control module 425 can communicate with and/or otherwise derive IoT information from the device in which the wireless power receiver client 400 is embedded. Although not shown, in some embodiments, the wireless power receiver client 400 can have one or more data connections (wired or wireless) with the device in which the wireless power receiver client 400 is embedded over which IoT information can be obtained. Alternatively, or additionally, IoT information can be determined and/or inferred by the wireless power receiver client 400, e.g., via one or more sensors. As discussed above, the IoT information can include, but is not limited to, information about the capabilities of the device in which the wireless power receiver client 400 is embedded, usage information of the device in which the wireless power receiver client 400 is embedded, power levels of the battery or batteries of the device in which the wireless power receiver client 400 is embedded, and/or information obtained or inferred by the device in which the wireless power receiver client is embedded or the wireless power receiver client itself, e.g., via sensors, etc.

[0055] In some embodiments, a client identifier (ID) module 415 stores a client ID that can uniquely identify the wireless power receiver client 400 in a wireless power delivery environment. For example, the ID can be transmitted to one or more wireless power transmission systems when communication is established. In some embodiments, wireless power receiver clients may also be able to receive and identify other wireless power receiver clients in a wireless power delivery environment based on the client ID.

[0056] An optional motion sensor 495 can detect motion and signal the control logic 410 to act accordingly. For example, a device receiving power may integrate motion detection mechanisms such as accelerometers or equivalent

mechanisms to detect motion. Once the device detects that it is in motion, it may be assumed that it is being handled by a user, and would trigger a signal to the array to either to stop transmitting power, or to lower the power transmitted to the device. In some embodiments, when a device is used in a moving environment like a car, train or plane, the power might only be transmitted intermittently or at a reduced level unless the device is critically low on power.

[0057] FIGS. 5A and 5B depict diagrams illustrating an example multipath wireless power delivery environment 500, according to some embodiments. The multipath wireless power delivery environment 500 includes a user operating a wireless device 502 including one or more wireless power receiver clients 503. The wireless device 502 and the one or more wireless power receiver clients 503 can be wireless device 102 of FIG. 1 and wireless power receiver client 103 of FIG. 1 or wireless power receiver client 400 of FIG. 4, respectively, although alternative configurations are possible. Likewise, wireless power transmission system 501 can be wireless power transmission system 101 FIG. 1 or wireless power transmission system 300 of FIG. 3, although alternative configurations are possible. The multipath wireless power delivery environment 500 includes reflective objects 506 and various absorptive objects, e.g., users, or humans, furniture, etc.

[0058] Wireless device 502 includes one or more antennas (or transceivers) that have a radiation and reception pattern 510 in three-dimensional space proximate to the wireless device 102. The one or more antennas (or transceivers) can be wholly or partially included as part of the wireless device 102 and/or the wireless power receiver client (not shown). For example, in some embodiments one or more antennas, e.g., Wi-Fi, Bluetooth, etc. of the wireless device 502 can be utilized and/or otherwise shared for wireless power reception. As shown in the example of FIGS. 5A and 5B, the radiation and reception pattern 510 comprises a lobe pattern with a primary lobe and multiple side lobes. Other patterns are also possible.

[0059] The wireless device 502 transmits a beacon (or calibration) signal over multiple paths to the wireless power transmission system 501. As discussed herein, the wireless device 502 transmits the beacon in the direction of the radiation and reception pattern 510 such that the strength of the received beacon signal by the wireless power transmission system, e.g., received signal strength indication (RSSI), depends on the radiation and reception pattern 510. For example, beacon signals are not transmitted where there are nulls in the radiation and reception pattern 510 and beacon signals are the strongest at the peaks in the radiation and reception pattern 510, e.g., peak of the primary lobe. As shown in the example of FIG. 5A, the wireless device 502 transmits beacon signals over five paths P1-P5. Paths P4 and P5 are blocked by reflective and/or absorptive object 506. The wireless power transmission system 501 receives beacon signals of increasing strengths via paths P1-P3. The bolder lines indicate stronger signals. In some embodiments the beacon signals are directionally transmitted in this manner, for example, to avoid unnecessary RF energy exposure to the user.

[0060] A fundamental property of antennas is that the receiving pattern (sensitivity as a function of direction) of an antenna when used for receiving is identical to the far-field radiation pattern of the antenna when used for transmitting. This is a consequence of the reciprocity theorem in electro-

magnetism. As shown in the example of FIGS. 5A and 5B, the radiation and reception pattern 510 is a three-dimensional lobe shape. However, the radiation and reception pattern 510 can be any number of shapes depending on the type or types, e.g., horn antennas, simple vertical antenna, etc. used in the antenna design. For example, the radiation and reception pattern 510 can comprise various directive patterns. Any number of different antenna radiation and reception patterns are possible for each of multiple client devices in a wireless power delivery environment.

[0061] Referring again to FIG. 5A, the wireless power transmission system 501 receives the beacon (or calibration) signal via multiple paths P1-P3 at multiple antennas or transceivers. As shown, paths P2 and P3 are direct line of sight paths while path P1 is a non-line of sight path. Once the beacon (or calibration) signal is received by the wireless power transmission system 501, the power transmission system 501 processes the beacon (or calibration) signal to determine one or more receive characteristics of the beacon signal at each of the multiple antennas. For example, among other operations, the wireless power transmission system 501 can measure the phases at which the beacon signal is received at each of the multiple antennas or transceivers.

[0062] The wireless power transmission system 501 processes the one or more receive characteristics of the beacon signal at each of the multiple antennas to determine or measure one or more wireless power transmit characteristics for each of the multiple RF transceivers based on the one or more receive characteristics of the beacon (or calibration) signal as measured at the corresponding antenna or transceiver. By way of example and not limitation, the wireless power transmit characteristics can include phase settings for each antenna or transceiver, transmission power settings, etc.

[0063] As discussed herein, the wireless power transmission system 501 determines the wireless power transmit characteristics such that, once the antennas or transceivers are configured, the multiple antennas or transceivers are operable to transmit a wireless power signal that matches the client radiation and reception pattern in the three-dimensional space proximate to the client device. FIG. 5B illustrates the wireless power transmission system 501 transmitting wireless power via paths P1-P3 to the wireless device 502. Advantageously, as discussed herein, the wireless power signal matches the client radiation and reception pattern 510 in the three-dimensional space proximate to the client device. Said another way, the wireless power transmission system will transmit the wireless power signals in the direction in which the wireless power receiver has maximum gain, e.g., will receive the most wireless power. As a result, no signals are sent in directions in which the wireless power receiver cannot receive power, e.g., nulls and blockages. In some embodiments, the wireless power transmission system 501 measures the RSSI of the received beacon signal and if the beacon is less than a threshold value, the wireless power transmission system will not send wireless power over that path.

[0064] The three paths shown in the example of FIGS. 5A and 5B are illustrated for simplicity, it is appreciated that any number of paths can be utilized for transmitting power to the wireless device 502 depending on, among other factors, reflective and absorptive objects in the wireless power delivery environment.

**[0065]** Although the example of FIG. 5A illustrates transmitting a beacon (or calibration) signal in the direction of the radiation and reception pattern 510, it is appreciated that, in some embodiments, beacon signals can alternatively or additionally be omni-directionally transmitted.

## II. WPTS Calibration in Multipath Environment

**[0066]** As discussed above, wireless power transmission systems can wirelessly transmit power to wireless power receiver clients in a multipath wireless power delivery environment by focusing wireless power signals over multiple paths to specific areas or regions (also referred to as focal points) proximate to a wireless power receiver client. In order for this operation to be successful, the multiple signals must be appropriately phased such that the signals are additive (or constructively interfere) at the focal point. The process of adjusting the phases to ensure that the signals arrive at the receiver in-phase is referred to herein as calibration.

**[0067]** The calibration process can be performed in a number of ways at various times depending on the design of the wireless power transmission system and other factors. For example, in some embodiments, the calibration process occurs at system startup to account for ambiguity in the phases of the multiple antennas (or antennae elements). The calibration can be repeated if, for example, there are significant environmental changes, e.g., in temperature, etc. In some embodiments, the system can be designed to startup in the same phase state every time. With these designs, the calibration may only need to occur once, e.g., one-time factory calibration. However, these systems can be very complex and expensive.

**[0068]** Accordingly, the typical approach to calibration is to have a client antenna (e.g., calAE) located in the far field send a signal that presents a uniform waveform when it hits an antenna array. Unfortunately, this solution is untenable in a multipath environment for a variety of reasons. First, indoor environments have reflections that disrupt or change the uniformity, e.g., phase distribution, of waveforms as they are received at the array. Regardless, a client antenna typically needs to be located in the far field for calibration, which is much further away than the client can get from the charger in a multipath environment, e.g., indoor environment.

**[0069]** Techniques are discussed herein for calibrating wireless power transmission systems for operation in multipath wireless power delivery environments. Importantly, at least one unique aspect of the techniques discussed herein is that they are performed round trip. That is, the transmit path is characterized, the receive path is characterized, and then the system identifies differences between the ideal and the detected paths. Advantageously, by exercising the transmit and the receive paths, the environmental constraints can be identified and accounted for so that the client does not need to be located in the far field.

**[0070]** As discussed above, the wireless power transmission system must be calibrated if there is any ambiguity in the phase. Phase error can be introduced from a variety of sources. For example, phase error can be inside the detection circuit itself, the RF signal source on each antenna element, within the traces in the system, and/or based on other factors, e.g., environmental factors such as thermal drift, etc. Additional sources of phase error can include: MBC Clock Skew in Distribution, MBC Clock Buffer Temperature Drift,

Warm-up Time and Recalibration errors/drift, Clock Distribution Path Length Differences (Cabled solution), and PLL Start-up Phase inconsistencies. Potentially other unidentified sources of error as well. The techniques discussed herein are a ‘catch-all’ providing a single correction for the sum of all errors. More specifically, the techniques discussed herein account for any and all ambiguity in the phase so that all antennas are aligned to a common reference.

**[0071]** Definitions and components discussed herein:

**[0072]** Calibration AE (CalAE): Modified AE design that behaves as a mock client. Capable of sending a Beacon (or calibration) signal and detecting RF energy received at its antenna. Positioned external to main array structure.

**[0073]** Reference AE/Antenna (RefAE): A single antenna is selected from the array to provide a common reference. All other AE Antennas are aligned to this Reference.

**[0074]** All other AE/Ant (DUT): All other Antenna are calibrated one at a time against the Reference AE.

**[0075]** FIG. 6 depicts a sequence diagram illustrating an example technique for calibrating a wireless power transmission system in a multipath wireless power delivery environment, according to some embodiments. The calibration technique discussed with reference to FIG. 6 takes into account each source of error to align the RF output to a zero-degree reference. The technique includes two processes: (1) static tune; and (2) beacon tune. The order in which the processes are performed is not important. The calibration value is the difference between the values derived by each process.

**[0076]** To begin, (at step 1) the CalAE Beacons, the RefAE and DUT detect the phase. The detected phases are saved to MBC. Next, (at step 2) the MBC commands RefAE to continuously transmit Detected Phase. The MBC (at step 3) commands DUT to transmit signals in sequential phase settings [0, 22, . . . , 337]. The CalAE, (at step 4), collects data on received power [Prx0, Prx22, . . . , Prx337] for MBC. The MBC, (at step 5), determines optimum phase transmitted from DUT by peak power received by the CalAE, i.e., Optimum Phase=Pmax(Prx0, Prx22, . . . , Prx337). The MBC, (at step 6), calculates the calibration value for DUT as difference between Detected Phase and Optimum Phase.

**[0077]** Steps 1-6 repeated for each antenna element (AE)/Antenna in the array. The calibration value is added to all detected phases during normal operation.

**[0078]** FIGS. 7A-7C depict a system illustrating an example technique for calibrating a wireless power transmission system in a multipath wireless power delivery environment, according to some embodiments. The calibration technique discussed with reference to FIGS. 7A-7C takes into account multiple sources of error to align all antenna elements at the RF output to a zero-degree reference. Like FIG. 6, the technique includes two processes: (1) static tune; and (2) beacon tune. The order in which the processes are performed is not important. The calibration value is the difference between the values derived by each process.

**[0079]** Referring first to FIG. 7A, FIG. 7A illustrates a beacon from the calibration antenna (labeled CalAE). As shown, there is a vector drawing for a phase delay along each path and the individual phase references (essentially the total phase shift through that element). The system aligns to the phi ref 1, channel 1, antenna 1 as shown. Antenna 1

and antenna 2 are detecting and have different internal phase references so they detect different phases from the beacon signal relative to one another. FIG. 7B illustrates values that the antennas detect. The values are measured phases plus the phase received.

**[0080]** FIG. 7C shows the next step where the reference antenna (antenna 1) sends back what it detected and the other antenna (antenna 2) sends back a signal with sequential phase settings 0-337. It should be noted that more or fewer phase settings are possible. The calAE records the peak power as shown. Additionally, the calculation of phase is shown.

**[0081]** FIG. 7C also illustrates an attempt to correlate the detected phase, what should be transmitted for the peak amplitude and what the system knows is the correct value. All values are fed back to the master bus controller (e.g., central controller) which controls the calibration process, the calAE and the test antennas (DUT). As shown in the example of FIG. 7C, a rough calculation of the peak value minus the detected value for the phase is shown as well as an example of how the equation is resolved.

**[0082]** FIGS. 8A and 8B illustrate an example uncalibrated system and an example calibrated system, respectively, according to some embodiments. The signals shown in FIG. 8A are out of phase and, thus, do not provide for the ability to transmit power because the signals do not constructively interfere at a power receiver client (shown as calAE in the example of FIGS. 8A and 8B). In FIG. 8A, without calibration, the multiple antennas of the WPTS transmit the complex conjugate back over the same phase path from which the beacon signal is received (see  $\phi$  ref 1 and  $\phi$  ref 2 arriving at the calAE). Depending on  $\phi$  ref 1 and  $\phi$  ref 2, a client would likely receive different levels of power (or possibly no power at all) as the signals are likely out of phase.

**[0083]** In FIG. 8B the power is transmitted after adding in the calculated calibration value so that the signals constructively interfere (generate a focused signal) for power reception by a receiver client. More specifically, the cal value is added in so that both signals align to the same phase at the calAE (or client). As discussed herein, without calibration, it is possible (if not likely) that zero power is transferred to a client because the signals are not unaligned and, thus, not focused. As discussed herein, the system is based on additive constructive interference of many in phase signals all hitting the same point at the same time to constructively interfere. When the system is not calibrated, a combination of constructive and destructive interference occurs which can lead to significant power loss (random noise) or no power transfer to the client.

#### Integrated Calibration

**[0084]** To this point, a dedicated external calibration module (CalAE) has been discussed. FIG. 9 illustrates an example wireless power transmission system where the coupling across the feed lines to the antennas functions as a calibration AE within the enclosure of the wireless power transmission system (i.e., internal to the system-integrated calibration). The internal coupling can utilize the same algorithm discussed herein (e.g., with reference to FIG. 6) to accomplish the calibration.

**[0085]** In the example of FIG. 9, the cylindrical shape of the wireless power transmission system allows for the coupling across the feed lines to the antennas. The only

limitation of the internal calAE is that it has to be “heard” and “hear” all of the other antennas. The internal calAE is able to couple energy in and out of all of the other antennas. Whether the CalAE does that through antennas over the air or through internal coupling is not important to the calibration technique or algorithm as long as the internal CalAE uses a consistent path and can detect and output a signal that can be detected by all of the other antennas.

#### Factory Calibration

**[0086]** The embodiments above are primarily discussed with reference to run-time calibration, e.g., have to calibrate each time startup. However, in some embodiments, calibration can also be performed at manufacturing time. For example, the system can attempt to account for any phase differences so that it starts up in the same phase state every time, e.g., with fixed path lengths. Unfortunately, fixed paths lengths can be difficult to achieve, costly and wasteful.

**[0087]** Another way one-time factory calibration can be achieved is by determining the path-length differences (and all other potential phase differences) once, and store these values in calibration registers that adjust the system automatically each time the system is started up. Thus, no calibration needs to be performed at startup. For example, the design can match clock lengths and signal traces on the hardware through the whole system. However, this can lead to more complex designs resulting a more intricate PCBs, etc.,. For example, if the longest trace has to be 12 inches, the rest of traces have to also be 12 inches, even if the closest Antenna Matrix Board (AMB) is only two inches away which will force the designer to find an extra 10 inches of run on the PCB to match the length of all signals. By pushing some of the complexity into calibration, the techniques described herein facilitate a more relaxed design.

**[0088]** The calibration values can be determined during a manufacturing time. Other variables could also be taken into account using this method. For example, any phase variability constraints such as environment, thermal and other design characteristics that are not accounted for during the design phase can be fixed through calibration. For example, manufacturing time calibration can occur in a controlled environment at various temperatures to account for thermal drift. The values can be stored in registers and the wireless power transmission system can dynamically adjust the values (either at startup, periodically, or continuously) based on the current environmental conditions. Other register values can also be estimated and stored. The values can be adjusted over the life of the part, etc. While the various designs discussed here only require a single calibration at manufacturing time, the designs tend to be more complex as many variables need to be accounted for and values stored in registers for on-the-fly adjustments.

#### IV. Additional Calibration Examples

**[0089]** In addition to some of the information discussed herein, various approaches to calibration including conventional one-way approaches are described in greater detail below. More specifically, plane wave and known excitations are discussed. For example, when a plane wave is excited, the calibration antenna must be sufficiently far away from the antenna array so that the array collectively appears as a single point source. It should be noted that plane wave excitation describing the phase distribution across all the

antennas should be zero degrees because the wave is uniform. With such known wave excitations, it may not all be zero degrees but it is a known distribution, and should be the same every time.

**[0090]** For example, if one knew the phase distributions between antennas, a determination could be made as to where the system was focused (30 degrees from antenna 1, 0 degrees from antenna 2, etc.) e.g., at 20 cm directly in front of the system one would have a focused illumination. This is an example of a known wave distribution. One problem with this design is that for such calibration technique to work, it needs to be performed in an open field since reflections from actual obstacles in realistic setups (i.e., an office) would have an impact on the collected information. Also, this process does not account for the transmitter-side anomalies which may have a different phase error than the receive-side.

**[0091]** In-circuit calibration is related to internal coupling and involves a different algorithm. With this technique, external CalAE is removed and cell-to-cell calibration is performed. In cell-to-cell calibration, everything is referenced to antenna 0. With this approach, antenna 1 is calibrated, where the calibration values are stored relative to antenna 0. Antennas 1 and 2 go through the same routine which implicitly have antenna 2 being in phase with respect to antenna 0. This is more of a basic approach where the calibrating antennas are in close proximity to each other and coupling is assured (i.e., the antennas could hear each other constantly). Another approach that could be useful if, for example, the configuration of the charger does not provide sufficient coupling from any antenna to any other antenna. This technique can be used either on an antenna to antenna basis or group of antennas to group of antennas (have AMBs—antenna matrix boards phases).

**[0092]** In another embodiment, a super runtime feedback loop is implemented. For example, an antenna would know that it is supposed to output 14 degrees of phase difference, and continuously monitors itself and adjusts its phase, which helps to eliminate the need for calibration.

### III. Example Systems

**[0093]** FIG. 10 depicts a block diagram illustrating example components of a representative mobile device or tablet computer 1000 with a wireless power receiver or client in the form of a mobile (or smart) phone or tablet computer device, according to an embodiment. Various interfaces and modules are shown with reference to FIG. 10, however, the mobile device or tablet computer does not require all of modules or functions for performing the functionality described herein. It is appreciated that, in many embodiments, various components are not included and/or necessary for operation of the category controller. For example, components such as GPS radios, cellular radios, and accelerometers may not be included in the controllers to reduce costs and/or complexity. Additionally, components such as ZigBee radios and RFID transceivers, along with antennas, can populate the Printed Circuit Board.

**[0094]** The wireless power receiver client can be a power receiver client 103 of FIG. 1, although alternative configurations are possible. Additionally, the wireless power receiver client can include one or more RF antennas for reception of power and/or data signals from a power transmission system, e.g., wireless power transmission system 101 of FIG. 1.

**[0095]** FIG. 11 depicts a diagrammatic representation of a machine, in the example form, of a computer system within which a set of instructions, for causing the machine to perform any one or more of the methodologies discussed herein, may be executed.

**[0096]** In the example of FIG. 11, the computer system includes a processor, memory, non-volatile memory, and an interface device. Various common components (e.g., cache memory) are omitted for illustrative simplicity. The computer system 1100 is intended to illustrate a hardware device on which any of the components depicted in the example of FIG. 1 (and any other components described in this specification) can be implemented. For example, the computer system can be any radiating object or antenna array system. The computer system can be of any applicable known or convenient type. The components of the computer system can be coupled together via a bus or through some other known or convenient device.

**[0097]** The processor may be, for example, a conventional microprocessor such as an Intel Pentium microprocessor or Motorola power PC microprocessor. One of skill in the relevant art will recognize that the terms “machine-readable (storage) medium” or “computer-readable (storage) medium” include any type of device that is accessible by the processor.

**[0098]** The memory is coupled to the processor by, for example, a bus. The memory can include, by way of example but not limitation, random access memory (RAM), such as dynamic RAM (DRAM) and static RAM (SRAM). The memory can be local, remote, or distributed.

**[0099]** The bus also couples the processor to the non-volatile memory and drive unit. The non-volatile memory is often a magnetic floppy or hard disk, a magnetic-optical disk, an optical disk, a read-only memory (ROM), such as a CD-ROM, EPROM, or EEPROM, a magnetic or optical card, or another form of storage for large amounts of data. Some of this data is often written, by a direct memory access process, into memory during execution of software in the computer 1300. The non-volatile storage can be local, remote, or distributed. The non-volatile memory is optional because systems can be created with all applicable data available in memory. A typical computer system will usually include at least a processor, memory, and a device (e.g., a bus) coupling the memory to the processor.

**[0100]** Software is typically stored in the non-volatile memory and/or the drive unit. Indeed, for large programs, it may not even be possible to store the entire program in the memory. Nevertheless, it should be understood that for software to run, if necessary, it is moved to a computer readable location appropriate for processing, and for illustrative purposes, that location is referred to as the memory in this paper. Even when software is moved to the memory for execution, the processor will typically make use of hardware registers to store values associated with the software, and local cache that, ideally, serves to speed up execution. As used herein, a software program is assumed to be stored at any known or convenient location (from non-volatile storage to hardware registers) when the software program is referred to as “implemented in a computer-readable medium”. A processor is considered to be “configured to execute a program” when at least one value associated with the program is stored in a register readable by the processor.



**[0101]** The bus also couples the processor to the network interface device. The interface can include one or more of a modem or network interface. It will be appreciated that a modem or network interface can be considered to be part of the computer system. The interface can include an analog modem, isdn modem, cable modem, token ring interface, satellite transmission interface (e.g. "direct PC"), or other interfaces for coupling a computer system to other computer systems. The interface can include one or more input and/or output devices. The I/O devices can include, by way of example but not limitation, a keyboard, a mouse or other pointing device, disk drives, printers, a scanner, and other input and/or output devices, including a display device. The display device can include, by way of example but not limitation, a cathode ray tube (CRT), liquid crystal display (LCD), or some other applicable known or convenient display device. For simplicity, it is assumed that controllers of any devices not depicted in the example of FIG. 9 reside in the interface.

**[0102]** In operation, the computer system 1100 can be controlled by operating system software that includes a file management system, such as a disk operating system. One example of operating system software with associated file management system software is the family of operating systems known as Windows® from Microsoft Corporation of Redmond, Washington, and their associated file management systems. Another example of operating system software with its associated file management system software is the Linux operating system and its associated file management system. The file management system is typically stored in the non-volatile memory and/or drive unit and causes the processor to execute the various acts required by the operating system to input and output data and to store data in the memory, including storing files on the non-volatile memory and/or drive unit.

**[0103]** Some portions of the detailed description may be presented in terms of algorithms and symbolic representations of operations on data bits within a computer memory. These algorithmic descriptions and representations are the means used by those skilled in the data processing arts to most effectively convey the substance of their work to others skilled in the art. An algorithm is here, and generally, conceived to be a self-consistent sequence of operations leading to a desired result. The operations are those requiring physical manipulations of physical quantities. Usually, though not necessarily, these quantities take the form of electrical or magnetic signals capable of being stored, transferred, combined, compared, and otherwise manipulated. It has proven convenient at times, principally for reasons of common usage, to refer to these signals as bits, values, elements, symbols, characters, terms, numbers, or the like.

**[0104]** It should be borne in mind, however, that all of these and similar terms are to be associated with the appropriate physical quantities and are merely convenient labels applied to these quantities. Unless specifically stated otherwise, as apparent from the following discussion, it is appreciated that throughout the description, discussions utilizing terms such as "processing" or "computing" or "calculating" or "determining" or "displaying" or the like, refer to the action and processes of a computer system, or similar electronic computing device, that manipulates and transforms data represented as physical (electronic) quantities within the computer system's registers and memories into other data similarly represented as physical quantities within

the computer system memories or registers or other such information storage, transmission or display devices.

**[0105]** The algorithms and displays presented herein are not inherently related to any particular computer or other apparatus. Various general purpose systems may be used with programs in accordance with the teachings herein, or it may prove convenient to construct more specialized apparatus to perform the methods of some embodiments. The required structure for a variety of these systems will appear from the description below. In addition, the techniques are not described with reference to any particular programming language, and various embodiments may thus be implemented using a variety of programming languages.

**[0106]** In alternative embodiments, the machine operates as a standalone device or may be connected (e.g., networked) to other machines. In a networked deployment, the machine may operate in the capacity of a server or a client machine in a client-server network environment or as a peer machine in a peer-to-peer (or distributed) network environment.

**[0107]** The machine may be a server computer, a client computer, a personal computer (PC), a tablet PC, a laptop computer, a set-top box (STB), a personal digital assistant (PDA), a cellular telephone, an iPhone, a Blackberry, a processor, a telephone, a web appliance, a network router, switch or bridge, or any machine capable of executing a set of instructions (sequential or otherwise) that specify actions to be taken by that machine.

**[0108]** While the machine-readable medium or machine-readable storage medium is shown in an exemplary embodiment to be a single medium, the term "machine-readable medium" and "machine-readable storage medium" should be taken to include a single medium or multiple media (e.g., a centralized or distributed database, and/or associated caches and servers) that store the one or more sets of instructions. The term "machine-readable medium" and "machine-readable storage medium" shall also be taken to include any medium that is capable of storing, encoding or carrying a set of instructions for execution by the machine and that cause the machine to perform any one or more of the methodologies of the presently disclosed technique and innovation.

**[0109]** In general, the routines executed to implement the embodiments of the disclosure, may be implemented as part of an operating system or a specific application, component, program, object, module or sequence of instructions referred to as "computer programs." The computer programs typically comprise one or more instructions set at various times in various memory and storage devices in a computer, and that, when read and executed by one or more processing units or processors in a computer, cause the computer to perform operations to execute elements involving the various aspects of the disclosure.

**[0110]** Moreover, while embodiments have been described in the context of fully functioning computers and computer systems, those skilled in the art will appreciate that the various embodiments are capable of being distributed as a program product in a variety of forms, and that the disclosure applies equally regardless of the particular type of machine or computer-readable media used to actually effect the distribution.

**[0111]** Further examples of machine-readable storage media, machine-readable media, or computer-readable (storage) media include but are not limited to recordable type

media such as volatile and non-volatile memory devices, floppy and other removable disks, hard disk drives, optical disks (e.g., Compact Disk Read-Only Memory (CDROMS), Digital Versatile Disks, (DVDs), etc.), among others, and transmission type media such as digital and analog communication links.

**[0112]** Unless the context clearly requires otherwise, throughout the description and the claims, the words “comprise,” “comprising,” and the like are to be construed in an inclusive sense, as opposed to an exclusive or exhaustive sense; that is to say, in the sense of “including, but not limited to.” As used herein, the terms “connected,” “coupled,” or any variant thereof, means any connection or coupling, either direct or indirect, between two or more elements; the coupling of connection between the elements can be physical, logical, or a combination thereof. Additionally, the words “herein,” “above,” “below,” and words of similar import, when used in this application, shall refer to this application as a whole and not to any particular portions of this application. Where the context permits, words in the above Detailed Description using the singular or plural number may also include the plural or singular number respectively. The word “or,” in reference to a list of two or more items, covers all of the following interpretations of the word: any of the items in the list, all of the items in the list, and any combination of the items in the list.

**[0113]** The above detailed description of embodiments of the disclosure is not intended to be exhaustive or to limit the teachings to the precise form disclosed above. While specific embodiments of, and examples for, the disclosure are described above for illustrative purposes, various equivalent modifications are possible within the scope of the disclosure, as those skilled in the relevant art will recognize. For example, while processes or blocks are presented in a given order, alternative embodiments may perform routines having steps, or employ systems having blocks, in a different order, and some processes or blocks may be deleted, moved, added, subdivided, combined, and/or modified to provide alternative or subcombinations. Each of these processes or blocks may be implemented in a variety of different ways. Also, while processes or blocks are, at times, shown as being performed in a series, these processes or blocks may instead be performed in parallel, or may be performed at different times. Further, any specific numbers noted herein are only examples: alternative implementations may employ differing values or ranges.

**[0114]** The teachings of the disclosure provided herein can be applied to other systems, not necessarily the system described above. The elements and acts of the various embodiments described above can be combined to provide further embodiments.

**[0115]** Any patents and applications and other references noted above, including any that may be listed in accompanying filing papers, are incorporated herein by reference. Aspects of the disclosure can be modified, if necessary, to employ the systems, functions, and concepts of the various references described above to provide yet further embodiments of the disclosure.

**[0116]** These and other changes can be made to the disclosure in light of the above Detailed Description. While the above description describes certain embodiments of the disclosure, and describes the best mode contemplated, no matter how detailed the above appears in text, the teachings can be practiced in many ways. Details of the system may

vary considerably in its implementation details, while still being encompassed by the subject matter disclosed herein. As noted above, particular terminology used when describing certain features or aspects of the disclosure should not be taken to imply that the terminology is being redefined herein to be restricted to any specific characteristics, features, or aspects of the disclosure with which that terminology is associated. In general, the terms used in the following claims should not be construed to limit the disclosure to the specific embodiments disclosed in the specification, unless the above Detailed Description section explicitly defines such terms. Accordingly, the actual scope of the disclosure encompasses not only the disclosed embodiments, but also all equivalent ways of practicing or implementing the disclosure under the claims.

**[0117]** While certain aspects of the disclosure are presented below in certain claim forms, the inventors contemplate the various aspects of the disclosure in any number of claim forms. For example, while only one aspect of the disclosure is recited as a means-plus-function claim under 35 U.S.C. § 112, ¶6, other aspects may likewise be embodied as a means-plus-function claim, or in other forms, such as being embodied in a computer-readable medium. (Any claims intended to be treated under 35 U.S.C. § 112, ¶6 will begin with the words “means for”.) Accordingly, the applicant reserves the right to add additional claims after filing the application to pursue such additional claim forms for other aspects of the disclosure.

**[0118]** The detailed description provided herein may be applied to other systems, not necessarily only the system described above. The elements and acts of the various examples described above can be combined to provide further implementations of the invention. Some alternative implementations of the invention may include not only additional elements to those implementations noted above, but also may include fewer elements. These and other changes can be made to the invention in light of the above Detailed Description. While the above description defines certain examples of the invention, and describes the best mode contemplated, no matter how detailed the above appears in text, the invention can be practiced in many ways. Details of the system may vary considerably in its specific implementation, while still being encompassed by the invention disclosed herein. As noted above, particular terminology used when describing certain features or aspects of the invention should not be taken to imply that the terminology is being redefined herein to be restricted to any specific characteristics, features, or aspects of the invention with which that terminology is associated. In general, the terms used in the following claims should not be construed to limit the invention to the specific examples disclosed in the specification, unless the above Detailed Description section explicitly defines such terms. Accordingly, the actual scope of the invention encompasses not only the disclosed examples, but also all equivalent ways of practicing or implementing the invention.

What is claimed is:

1. A method of calibrating a wireless power transmission system for operation in a multipath environment, the method comprising:

characterizing a receive path from a calibration antennae element to a first antennae element of a plurality of antennae elements of the wireless power transmission system;

- characterizing a transmit path from the first antennae element to the calibration antennae element; and  
 comparing the transmit path to the receive path to determine a calibration value for the first antennae element in the multipath environment.
2. The method of claim 1, wherein characterizing the receive path from the calibration antennae element to the first antennae element further comprises:  
 determining a detected phase of a calibration signal at the first antennae element; and  
 determining a detected phase of the calibration signal at a reference antennae element, wherein the calibration signal is transmitted by the calibration antennae element.
3. The method of claim 2, wherein the reference antennae element comprises a feed line.
4. The method of claim 2, further comprising:  
 selecting the reference antennae element from the plurality of antennae elements of the wireless power transmission system.
5. The method of claim 2, wherein characterizing the transmit path from the first antennae element to the calibration antennae element further comprises:  
 directing the reference antennae element to continuously transmit a wireless power signal to the calibration antennae element at a reference phase setting; and  
 directing the first antennae element to transmit a wireless power signal at sequential phase settings.
6. The method of claim 5, wherein the reference phase setting comprises the detected phase of the calibration signal transmitted by the calibration antennae element at the reference antennae element minus a reference path delay phase.
7. The method of claim 5, further comprising:  
 collecting signal information as measured by the calibration antennae element from each of the sequential phase settings.
8. The method of claim 7, further comprising:  
 determining power measurements resulting from each of the sequential phase settings based on the signal information;  
 processing the power measurements to identify a peak power measurement; and  
 determining a phase corresponding to the peak power measurement.
9. The method of claim 8, wherein comparing the transmit path to the receive path to determine the calibration value for the first antennae element in the multipath environment further comprises:  
 calculating the calibration value for the first antennae element in the multipath environment based on the phase of the calibration signal and the phase corresponding to the peak power measurement.
10. The method of claim 1, further comprising:  
 prior to transmitting wireless power signals in the multipath environment, adjusting phase of the first antennae element based on the calibration value.
11. The method of claim 1, further comprising, for each additional antenna element of the plurality of antennae elements:  
 selecting an uncalibrated antennae element from the plurality of antennae elements;  
 characterizing a receive path from the calibration antennae element to the uncalibrated antennae element;
- characterizing a transmit path from the uncalibrated antennae element to the calibration antennae element; and  
 comparing the transmit path to the receive path to determine a calibration value for the uncalibrated antennae element in the multipath environment.
12. A wireless power transmission system, comprising:  
 an adaptively-phased antenna array having a plurality of antennae elements; and  
 control circuitry adapted to:  
 determine a detected phase of a calibration signal at a first antennae element of a plurality of antennae elements;  
 determine a detected phase of the calibration signal at a reference antennae element;  
 direct the reference antennae element to continuously transmit a wireless power signal to a calibration antennae element at a reference phase setting;  
 direct the first antennae element to transmit a wireless power signal to the calibration antennae element at sequential phase settings;  
 collect signal information as measured by the calibration antennae element from each of the sequential phase settings;  
 determine power measurements resulting from each of the sequential phase settings based on the signal information;  
 process the power measurements to identify a peak power measurement;  
 determine a phase corresponding to the peak power measurement; and  
 calculate a calibration value for the first antennae element based on the phase of the calibration signal and the phase corresponding to the peak power measurement.
13. The wireless power transmission system of claim 12, wherein the reference antennae element comprises a feed line.
14. The wireless power transmission system of claim 12, wherein the control circuitry is further adapted to:  
 select the reference antennae element from the plurality of antennae elements of the wireless power transmission system.
15. The wireless power transmission system of claim 12, wherein the reference phase setting comprises the detected phase of the calibration signal transmitted by the calibration antennae element at the reference antennae element minus a reference path delay phase.
16. The wireless power transmission system of claim 12, wherein the control circuitry is further adapted to:  
 prior to transmitting wireless power signals, adjust phase of the first antennae element based on the calibration value.
17. The wireless power transmission system of claim 12, wherein the control circuitry is further adapted to, for each additional antenna element of the plurality of antennae elements:  
 select an uncalibrated antennae element from the plurality of antenna elements;  
 determine a detected phase of another calibration signal at the uncalibrated antennae element;  
 determine a detected phase of the another calibration signal at the reference antennae element;  
 direct the reference antennae element to continuously transmit a wireless power signal to the calibration antennae element at the another reference phase setting;

direct the uncalibrated antennae element to transmit a wireless power signal at the sequential phase settings; collect signal information for the uncalibrated antenna element as measured by the calibration antennae element from each of the sequential phase settings; determine power measurements resulting from each of the sequential phase settings based on the signal information; process the power measurements to identify a peak power measurement; determine a phase corresponding to the peak power measurement; and calculate a calibration value for the uncalibrated antennae element based on the phase of the calibration signal and the phase corresponding to the peak power measurement.

**18.** An apparatus comprising:  
 one or more computer readable storage media; and  
 program instructions stored on the one or more computer readable storage media, wherein the program instructions, when executed by a processing system, direct the processing system to:  
 characterize a receive path from a calibration antennae element to a first antennae element of a plurality of antennae elements of a wireless power transmission system;  
 characterize a transmit path from the first antennae element to the calibration antennae element; and  
 compare the transmit path to the receive path to determine a calibration value for the first antennae element.

**19.** The apparatus of claim **18**, wherein to characterize the receive path from the calibration antennae element to the first antennae element, the program instructions, when executed by the processing system, further direct the processing system to:

determine a detected phase of a calibration signal at the first antennae element; and  
 determine a detected phase of the calibration signal at a reference antennae element,  
 wherein the calibration signal is transmitted by the calibration antennae element.

**20.** The apparatus of claim **19**, wherein to characterize the transmit path from the first antennae element to the calibration antennae element, the program instructions, when executed by the processing system, further direct the processing system to:

direct the reference antennae element to continuously transmit a wireless power signal to the calibration antennae element at a reference phase setting;  
 direct the first antennae element to transmit a wireless power signal at sequential phase settings. collect signal information as measured by the calibration antennae element from each of the sequential phase settings;  
 determine power measurements resulting from each of the sequential phase settings based on the signal information;  
 process the power measurements to identify a peak power measurement; and  
 determine a phase corresponding to the peak power measurement.

\* \* \* \* \*