



(11) **EP 4 067 795 A1**

(12) **EUROPEAN PATENT APPLICATION**
published in accordance with Art. 153(4) EPC

(43) Date of publication:
05.10.2022 Bulletin 2022/40

(51) International Patent Classification (IPC):
F25D 31/00^(2006.01)

(21) Application number: **20893899.3**

(52) Cooperative Patent Classification (CPC):
F25D 11/02; F25D 17/06; F25D 21/02; F25D 29/00; F25D 31/00

(22) Date of filing: **11.06.2020**

(86) International application number:
PCT/CN2020/095499

(87) International publication number:
WO 2021/103483 (03.06.2021 Gazette 2021/22)

(84) Designated Contracting States:
AL AT BE BG CH CY CZ DE DK EE ES FI FR GB GR HR HU IE IS IT LI LT LU LV MC MK MT NL NO PL PT RO RS SE SI SK SM TR
Designated Extension States:
BA ME
Designated Validation States:
KH MA MD TN

(71) Applicants:
• **Qingdao Haier Special Electric Freezer Co., Ltd. Shandong 266101 (CN)**
• **Haier Smart Home Co., Ltd. Qingdao, Shandong 266101 (CN)**

(72) Inventor: **WANG, Deseng Qingdao, Shandong 266101 (CN)**

(30) Priority: **26.11.2019 CN 201911174842**

(74) Representative: **Lavoix Bayerstraße 83 80335 München (DE)**

(54) **AIR COOLING DEVICE CONTROL METHOD AND AIR COOLING DEVICE**

(57) The present invention discloses a method of controlling an air-cooling device and an air-cooling device. The air-cooling device enables two chambers to achieve simultaneous refrigeration by operating the compressor and the evaporation blower and opening the first damper and the second damper, by employing a structural design with a single evaporator + a single evaporation blower + two dampers + three heating wires, in conjunction with the control of operational relationship of the compressor, the evaporation blower, the heating wires and the dampers; to achieve simultaneous heating by stopping the compressor, operating the evaporation blower, opening the first damper and the second damper, and activating the first heating wire, the second heating wire and the compensatory heating wire; to achieve refrigeration in one chamber and heating in the other chamber by operating the compressor and the evaporation blower, opening the first damper and closing the second damper, and activating the second heating wire, in conjunction with the refrigeration and heating requirements and conditions such as the defrost temperature; in conjunction with the control in the above three manners, the thermostatic control of the air-cooling device with a single refrigeration system and dual temperature zones is achieved with a simple structure and process.

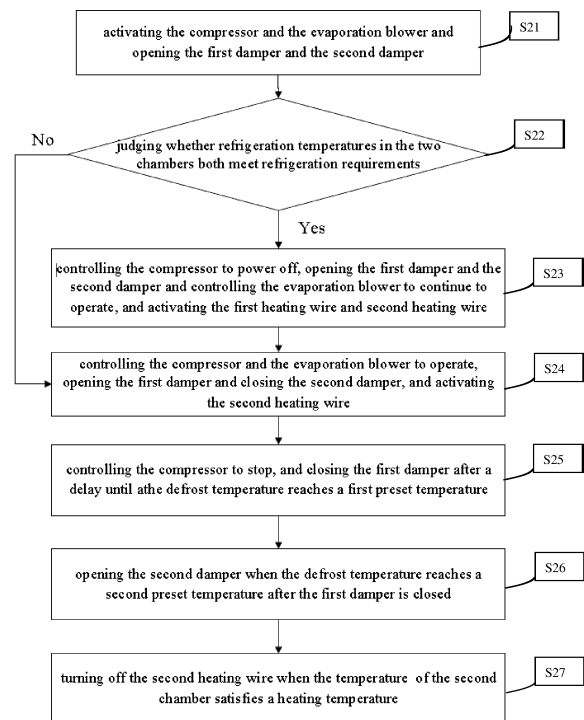

FIG. 2

EP 4 067 795 A1

Description**TECHNICAL FIELD**

[0001] The present invention relates to the technical field of air-cooling devices, and specifically to a method of controlling an air-cooling device and an air-cooling device.

BACKGROUND

[0002] In an air-cooling device such as a wine cabinet, thermostatic control is usually achieved for products in dual temperature zones in a manner of using a single evaporator + dual evaporation blowers. When a certain chamber needs to be refrigerated, the compressor operates, and the corresponding evaporation blowers operate to achieve the refrigeration of the chamber; this manner is structurally simple, but cannot achieve the thermostatic control under a lower ambient temperature as cold air blends each other seriously.

[0003] The thermostatic control can ensure optimal tastes and the storage of stored articles such as wines thereof. In the prior art, dual evaporators + dual evaporator blowers + dual heating wires + a solenoid valve are usually employed to control to switch to achieve the thermostatic control. When a first chamber needs to be refrigerated, the solenoid valve switches to the first chamber so that the evaporator in the first chamber refrigerates, and the evaporation blower in the first chamber operates; when a second chamber needs to be refrigerated, the solenoid valve switches to the second chamber so that the evaporator in the second chamber refrigerates, and the evaporation blower in the second chamber operates; switch of the solenoid valve is performing between the two chambers; when each chamber needs to be heated, the heating wire in the chamber is activated, and the evaporation blower in the chamber operates; this manner can achieve the thermostatic control, but it has problems such as a complicated structural design and a cumbersome production process.

SUMMARY

[0004] An object of the present invention is to provide a method of controlling an air-cooling device and a air-cooling device, which achieves the thermostatic control of the dual temperature zones of a single air-cooling system with a simplified structural design and process by employing a structural design with a single evaporator + a single evaporation blower + two dampers + three heating wires, in conjunction with the control of operational relationship of the compressor, the evaporation blower, the heating wires and the dampers.

[0005] To achieve the above object, the present invention employs the following technical solutions:

A method of controlling an air-cooling device, the air-

cooling device comprising: a cabinet; a liner which is mounted in the cabinet and whose internal cavity is partitioned into a first chamber and a second chamber; a first heating wire mounted in the first chamber; a second heating wire mounted in the second chamber; a single cycle refrigeration system comprising a circulation air passage, a compressor and an evaporator; a defrost sensor detecting defrost temperature is mounted on the evaporator; an evaporation blower mounted outside the liner; a first damper provided on the first chamber and connected to the circulation air passage; a second damper provided on the second chamber and connected to the circulation air passage;

wherein the controlling method comprises: controlling the compressor and the evaporation blower to operate, opening the first damper and closing the second damper, and activating the second heating wire; controlling the compressor to stop when the first chamber reaches a preset refrigeration temperature, and closing the first damper after a delay until the defrost temperature reaches a first preset temperature; turning off the second heating wire when the second chamber meets a heating temperature; and opening the second damper when the defrost temperature reaches the second preset temperature after a delay after the first damper is closed.

[0006] In further, the controlling method further comprises: controlling the evaporation blower to stop when the defrost temperature reaches the first preset temperature; and when the defrost temperature reaches the second preset temperature, controlling the evaporation blower to operate until the second chamber meets the heating temperature.

[0007] In further, the air-cooling device further comprises: a compensatory heating wire disposed on a rear side of the evaporator; the controlling method further comprises: activating the compensatory heating wire after the compressor stops.

[0008] In further, the specific operation of activating the compensatory heating wire is to activate the compensatory heating wire with a 100% current conduction rate.

[0009] In further, the controlling method further comprises: opening the first damper and the second damper, and controlling the evaporation blower to operate; activating the first heating wire, the second heating wire and the compensatory heating wire.

[0010] The present invention also provides an air-cooling device comprising: a cabinet; a liner which is mounted in the cabinet and whose internal cavity is partitioned into a first chamber and a second chamber; a first heating wire mounted in the first chamber; a second heating wire mounted in the second chamber; a single cycle refrigeration system comprising a circulation air passage, a compressor and an evaporator; a defrost sensor detecting defrost temperature is mounted on the evaporator; an evaporation blower mounted outside the liner; wherein

the air-cooling device further comprises: a first damper provided on the first chamber and connected to the circulation air passage; a second damper provided on the second chamber and connected to the circulation air passage; a single chamber air-cooling/heating control module configured to: control the compressor and the evaporation blower to operate, open the first damper and close the second damper, and activate the second heating wire; when the first chamber reaches a preset refrigeration temperature, control the compressor to stop, and close the first damper after a delay when the defrost temperature reaches a first preset temperature; close the second heating wire when the second chamber meets a heating temperature; and open the second damper after the first damper is closed until when the defrost temperature reaches a second preset temperature.

[0011] In further, the single chamber air-cooling/heating control module comprises: an evaporation blower control unit configured to: control the evaporation blower to stop when the defrost temperature reaches the first preset temperature; and control the evaporation blower to operate until the second chamber meets the heating temperature, when the defrost temperature reaches the second preset temperature.

[0012] In further, the air-cooling device further comprises: a compensatory heating wire disposed on a rear side of the evaporator; a compensatory heating control module configured to activate the compensatory heating wire after the compressor stops.

[0013] In further, the compensatory heating control module is specifically configured to activate the compensatory heating wire with a 100% current conduction rate.

[0014] In further, the air-cooling device further comprises: a full air-cooling control module configured to: open the first damper and second damper, and control the evaporation blower to operate; and activate the first heating wire, the second heating wire and the compensatory heating wire.

[0015] As compared with the prior art, the present invention has the following advantages and active effects: in the method of controlling an air-cooling device and the air-cooling device of the present invention, the thermostatic control is achieved by employing a single cycle refrigeration system, structurally with the circulation air passage, the compressor, the single evaporator, the single evaporation blower, and the first damper and second damper which are respectively disposed at the first chamber and second chamber and both connected to the circulation air passage; if both chambers need to be refrigerated, the compressor and evaporation blower are activated, and the two dampers are opened; if both chambers need to be heated, the compressor is controlled to stop and the evaporation blower is controlled to operate, the two dampers are closed, and the heating wires in the chambers are activated; if one chamber needs to be refrigerated and the other chamber needs to be heated, the damper of the chamber to be refrigerated is opened and the damper of the chamber to be heated is closed,

and the heating wire in the chamber to be heated is activated; when the temperature of the chamber to be refrigerated reaches the preset refrigeration temperature, the compressor is controlled to stop and the damper of the chamber to be refrigerated is closed after a delay when the defrost temperature reaches the first preset temperature; when the temperature of the chamber being heated meets the heating temperature, the heating wire therein is turned off, and the damper of the chamber being heated is opened when the defrost temperature reaches the second preset temperature after a delay after the damper of the chamber being refrigerated is closed. In conjunction with the control in the above three manners, the thermostatic control may be implemented individually for the two chambers respectively with the structure of the single air-cooling system. As compared with the dual evaporators + dual evaporation blowers + dual heating wires + an solenoid valve manner that can achieve the thermostatic control in the prior art, the single air-cooling system exhibits a more simplified structural design and process, and achieves the thermostatic control of the air-cooling device with the single air-cooling system and dual temperature zones with the simplified structural and process design.

[0016] Other features and advantages of the present invention will be made more apparent by reading through detailed depictions of embodiments of the present invention with reference to figures.

30 BRIEF DESCRIPTION OF THE DRAWINGS

[0017]

FIG. 1 illustrates a structural schematic view of an air-cooling device according to an embodiment of the present invention;

FIG. 2 illustrates a flow chart of a method of controlling an air-cooling device according to an embodiment of the present invention;

FIG. 3 illustrates a functional architecture view of an air-cooling device according to an embodiment of the present invention.

45 DETAILED DESCRIPTION

[0018] Specific embodiments of the present invention will be described in more detail below with reference to figures.

[0019] As shown in FIG. 1, an air-cooling device according to the present invention comprises a cabinet 1 and a liner 2, the liner 2 is mounted in the cabinet 1, the internal cavity of the liner 2 is partitioned into a first chamber 3 and a second chamber 4, a first heating wire 5 is mounted in the first chamber 3, and a second heating wire 6 is mounted in the second chamber 4; the air-cooling device employs a single cycle refrigeration system to achieve refrigeration; the single cycle refrigeration system comprises a circulation air passage 7, a compressor

8 and an evaporator 9, and is disposed on a rear side outside the liner 2; the rear side outside the liner 2 is further provided with an evaporation blower 10 on which is mounted a defrost sensor for detecting defrost temperature; a first damper 11 is provided on the first chamber 3 and connected to the circulation air passage 7; a second damper 12 is provided on the second chamber 4 and connected to the circulation air passage 7.

[0020] On the architecture of the air-cooling device shown in FIG. 1, the present invention provides a method of controlling the air-cooling device to achieve dual-temperature thermostatic control with the single cycle refrigeration system. Specifically, as shown in FIG. 2, the method comprises the following steps:

Step S21: activating the compressor and the evaporation blower and opening the first damper and the second damper.

[0021] An example is taken in which the air-cooling device activates refrigeration. After the air-cooling device is powered on, the single cycle refrigeration system is activated at first, and the first damper 11 and second damper 12 are opened to implement refrigeration for the first chamber 3 and second chamber 4, respectively.

[0022] Step S22: judging whether refrigeration temperature in the two chambers both meet refrigeration requirements.

[0023] During respective refrigeration in the two chambers, judgment is respectively made as to whether the refrigeration temperatures in the two chambers meet respective refrigeration requirements; after refrigeration in a period of time, there are two cases of the refrigeration in the two chambers: 1) the refrigeration temperatures in the two chambers both meet the refrigeration requirements and both chambers need to enter thermostatic regulation; 2) one chamber already meets its refrigeration requirement and needs to enter thermostatic regulation, and the other chamber does not meet its refrigeration requirement and needs to be further refrigerated.

[0024] Based on the above two cases, different steps are respectively performed according to the controlling method proposed by the present invention. When case 1 occurs first, step S23 is performed as follows: controlling the compressor to power off, opening the first damper and the second damper and controlling the evaporation blower to continue to operate, and activating the first heating wire and second heating wire.

[0025] After both chambers meet their respective refrigeration requirements, the first heating wire 5 of the first chamber 3, and the second heating wire 6 of the second chamber 4 are respectively activated to perform thermostatic control of the two chambers; in the embodiment of the present invention, a compensatory heating wire 13 is disposed on a rear side of the evaporator 9; upon thermostatic control, the defrost process of the evaporator 9 is accelerated through the operation of the compensatory heating wire 13 to quickly increase the surface temperature of the evaporator 9, and compensatory heating is performed for the thermostatic control

in the chambers through the operation of the evaporation blower 10. Specifically, when the compressor 8 stops to enter the thermostatic control, the evaporation blower 10 is kept in operation, the first damper 11 and second damper 12 are kept in the open state, and the compensatory heating wire 13 is activated. When both chambers perform thermostatic regulation through their respective heating wires, the heat of the compensatory heating wire 13, due to the action of the evaporation blower 10, enters the first chamber 3 through the first damper 11 and enters the second chamber 4 through the second damper 12 to perform compensation for the temperature in the two chambers, respectively.

[0026] When it occurs that one chamber needs to be heated, and the other chamber needs to be refrigerated when case 2 happens, or during the thermostatic regulation of step S23, an example is taken in which the first chamber 3 needs to be refrigerated and the second chamber 4 needs to be heated to, to perform:

Step S24: controlling the compressor and the evaporation blower to operate, opening the first damper and closing the second damper, and activating the second heating wire.

[0027] The compressor 8 is activated, the evaporation blower 10 continues to operate, the first damper 11 is opened and the second damper 12 is closed, the second heating wire 6 is activated to operate, and cold air running in the single cycle refrigeration system enters the first chamber 3 through the first damper 11 to refrigerate the first chamber 3; since the second damper 12 is closed, cold air does not enter the second chamber 2 and the second chamber 2 continues to be heated by the operation of the second heating wire 6. During this period, when the first chamber 3 reaches its preset refrigeration temperature, the following step is performed:

Step S25: controlling the compressor to stop, and closing the first damper after a delay until the defrost temperature reaches a first preset temperature.

[0028] After the first chamber 3 meets its refrigeration requirement again, the compressor 8 is controlled to stop, the defrost temperature detected by a defrost sensor is obtained, and the first damper 11 is closed when the defrost temperature reaches the first preset temperature T1.

[0029] After the compressor 8 stops, the compensatory heating wire 13 is activated immediately to assist the evaporator 8 in defrosting to increase the surface temperature of the evaporator 9 as quickly as possible to prepare for subsequent thermostatic regulation of the chambers.

[0030] Step S26: opening the second damper when the defrost temperature reaches a second preset temperature after the first damper is closed.

[0031] After the first damper 11 is closed, the second chamber 4 continued to be heated. The defrost sensor detects the defrost temperature. When the defrost temperature reaches the second preset temperature T2, the second damper 12 is opened. In the period of time after

the compressor 8 stops until the second damper 12 is opened, the compensatory heating wire 13 already starts to operate, and the defrost temperature on the surface of the evaporator 9 is high; after the second damper 12 is opened, the heating of the second chamber 4 can be compensated to quicken the thermostatic regulation of the second chamber 4.

[0032] Step S27: turning off the second heating wire when the temperature of the second chamber satisfies a heating temperature.

[0033] Regarding to the control of the evaporation blower 10, when the defrost temperature reaches the first preset temperature T1, i.e., when the first damper 11 is closed in step S25, the evaporation blower 10 is controlled to stop. At this time, the compensatory heating wire 13 already starts to perform auxiliary defrost for the evaporator 9 to increase the defrost temperature as soon as possible; when the defrost temperature reaches the second preset temperature T2, i.e., after the second air damper is opened in step S26, the evaporation blower 10 is again activated to operate, the heating of the second chamber 4 is compensated more quickly due to the action of the evaporation blower 10, the thermostatic regulation of the second chamber 4 is further quickened, and the second heating wire is turned off only when the second chamber satisfies the heating temperature.

[0034] Then, if the two chambers need to be refrigerated or heated again and again during the thermostatic control, the two chambers both may individually implement the thermostatic regulation in a manner that they are refrigerated simultaneously, or heated simultaneously, or one is refrigerated and the other is heated. As compared with the dual evaporators + dual evaporation blowers + dual heating wires + an solenoid valve manner that can achieve the thermostatic control in the prior art, the solution of the present invention is implemented based on the single cycle refrigeration system, exhibits a more simplified structural design and process, achieves the thermostatic control of the air-cooling device with a single air-cooling system and dual temperature zones, and is more adapted to be applied to the industry.

[0035] After the above step S26, when the compressor 8 is activated again, the second damper 2 needs to be closed immediately. That is to say, as long as the compressor 8 operates, the damper of the chamber which is currently being heated needs to be closed immediately to avoid the impact exerted by cold air on the heating.

[0036] After the first heating wire 5 and second heating wire 6 are activated, they both operate with a current conduction rate as required by a heating level, and the compensatory heating wire 13, after being activated, operates with a 100% current conduction rate.

[0037] Based on the abovementioned method of controlling the air-cooling method, as shown in FIG. 3, the air-cooling device according to the present invention further comprises a full air-cooling control module 31, a full heating control module 32 and a single chamber air-cooling/heating control module 33; the full air-cooling control

module 31 is configured to control the compressor 8 and the evaporation blower 10 to operate and open the first damper 11 and second damper 12; the full heating control module 32 is configured to control the compressor 8 to stop, open the first damper 11 and second damper 12, and control the evaporation blower 10 to operate; and activate the first heating wire 5, the second heating wire 6 and the compensatory heating wire 13 to operate; the single chamber air-cooling/heating control module 33 is configured to: control the compressor 8 and the evaporation blower 10 to operate, open the first damper 11 and close the second damper 12, and activate the second heating wire 6; when the temperature of the first chamber 3 reaches the preset refrigeration temperature, control the compressor 8 to stop, and close the first damper 11 after a delay when the defrost temperature reaches the first preset temperature T1; close the second heating wire 12 when the temperature of the second chamber 4 meets the heating temperature; and open the second damper 12 after the first damper 1 is closed until when the defrost temperature reaches the second preset temperature T2.

[0038] The single chamber air-cooling/heating control module 33 comprises an evaporation blower control unit 331 configured to control the evaporation blower 10 to stop when the defrost temperature reaches the first preset temperature T1; and control the evaporation blower 10 to operate until the temperature of the second chamber 4 meets the heating temperature, when the defrost temperature reaches the second preset temperature T2.

[0039] The air-cooling device according to the present invention further comprises a compensatory heating control module 34 configured to activate the compensatory heating wire 13 after the compressor 8 stops, specifically, activate the compensatory heating wire according to a 100% current conduction rate.

[0040] A specific control method for the air-cooling device to achieve the thermostatic control has already been described above in detail, and will not be detailed any more here.

[0041] It should be appreciated that the above depictions are not intended to limit the present invention, the present invention is not only limited to the above examples, and variations, modifications, additions or substitutes made by those having ordinary skill in the art within the spirit and scope of the present invention should also fall within the protection scope of the present invention.

Claims

1. A method of controlling an air-cooling device, the air-cooling device comprising:
 - a cabinet;
 - a liner which is mounted in the cabinet and whose internal cavity is partitioned into a first chamber and a second chamber;
 - a first heating wire mounted in the first chamber;

a second heating wire mounted in the second chamber;
 a single cycle refrigeration system comprising a circulation air passage, a compressor and an evaporator; a defrost sensor detecting defrost temperature is mounted on the evaporator; an evaporation blower mounted outside the liner;
 a first damper provided on the first chamber and connected to the circulation air passage;
 a second damper provided on the second chamber and connected to the circulation air passage;
 wherein the controlling method comprises:

controlling the compressor and the evaporation blower to operate, opening the first damper and closing the second damper, and activating the second heating wire;
 controlling the compressor to stop when the first chamber reaches a preset refrigeration temperature, and closing the first damper after a delay until the defrost temperature reaches a first preset temperature;
 turning off the second heating wire when the second chamber meets a heating temperature; and opening the second damper when the defrost temperature reaches the second preset temperature after a delay after the first damper is closed.

2. The method of controlling an air-cooling device according to claim 1, wherein the controlling method further comprises:

controlling the evaporation blower to stop when the defrost temperature reaches the first preset temperature; and
 when the defrost temperature reaches the second preset temperature, controlling the evaporation blower to operate until the second chamber meets the heating temperature.

3. The method of controlling an air-cooling device according to claim 1, wherein the air-cooling device further comprises:

a compensatory heating wire disposed on a rear side of the evaporator;
 the controlling method further comprises:
 activating the compensatory heating wire after the compressor stops.

4. The method of controlling an air-cooling device according to claim 3, wherein the specific operation of activating the compensatory heating wire is to activate the compensatory heating wire with a 100% current conduction rate.

5. The method of controlling an air-cooling device according to claim 1, wherein the controlling method further comprises:

opening the first damper and the second damper, and controlling the evaporation blower to operate;
 activating the first heating wire, the second heating wire and the compensatory heating wire.

6. An air-cooling device, comprising:

a cabinet;
 a liner which is mounted in the cabinet and whose internal cavity is partitioned into a first chamber and a second chamber;
 a first heating wire mounted in the first chamber;
 a second heating wire mounted in the second chamber;
 a single cycle refrigeration system comprising a circulation air passage, a compressor and an evaporator; a defrost sensor detecting defrost temperature is mounted on the evaporator;
 an evaporation blower mounted outside the liner;
 wherein the air-cooling device further comprises:

a first damper provided on the first chamber and connected to the circulation air passage;
 a second damper provided on the second chamber and connected to the circulation air passage;
 a single chamber air-cooling/heating control module configured to: control the compressor and the evaporation blower to operate, open the first damper and close the second damper, and activate the second heating wire; when the first chamber reaches a preset refrigeration temperature, control the compressor to stop, and close the first damper after a delay when the defrost temperature reaches a first preset temperature; close the second heating wire when the second chamber meets a heating temperature; and open the second damper after the first damper is closed until when the defrost temperature reaches a second preset temperature.

7. The air-cooling device according to claim 6, wherein the single chamber air-cooling/heating control module comprises:

an evaporation blower control unit configured to: control the evaporation blower to stop when the defrost temperature reaches the first preset temperature; and control the evaporation blower to operate

until the second chamber meets the heating temperature, when the defrost temperature reaches the second preset temperature.

- 8. The air-cooling device according to claim 6, wherein the air-cooling device further comprises: 5

- a compensatory heating wire disposed on a rear side of the evaporator;
 - a compensatory heating control module configured to activate the compensatory heating wire after the compressor stops. 10

- 9. The air-cooling device according to claim 8, wherein the compensatory heating control module is specifically configured to: 15
 - activate the compensatory heating wire with a 100% current conduction rate.

- 10. The air-cooling device according to claim 6, wherein the air-cooling device further comprises: 20
 - a full air-cooling control module configured to: open the first damper and second damper, and control the evaporation blower to operate; and activate the first heating wire, the second heating wire and the compensatory heating wire. 25

30

35

40

45

50

55

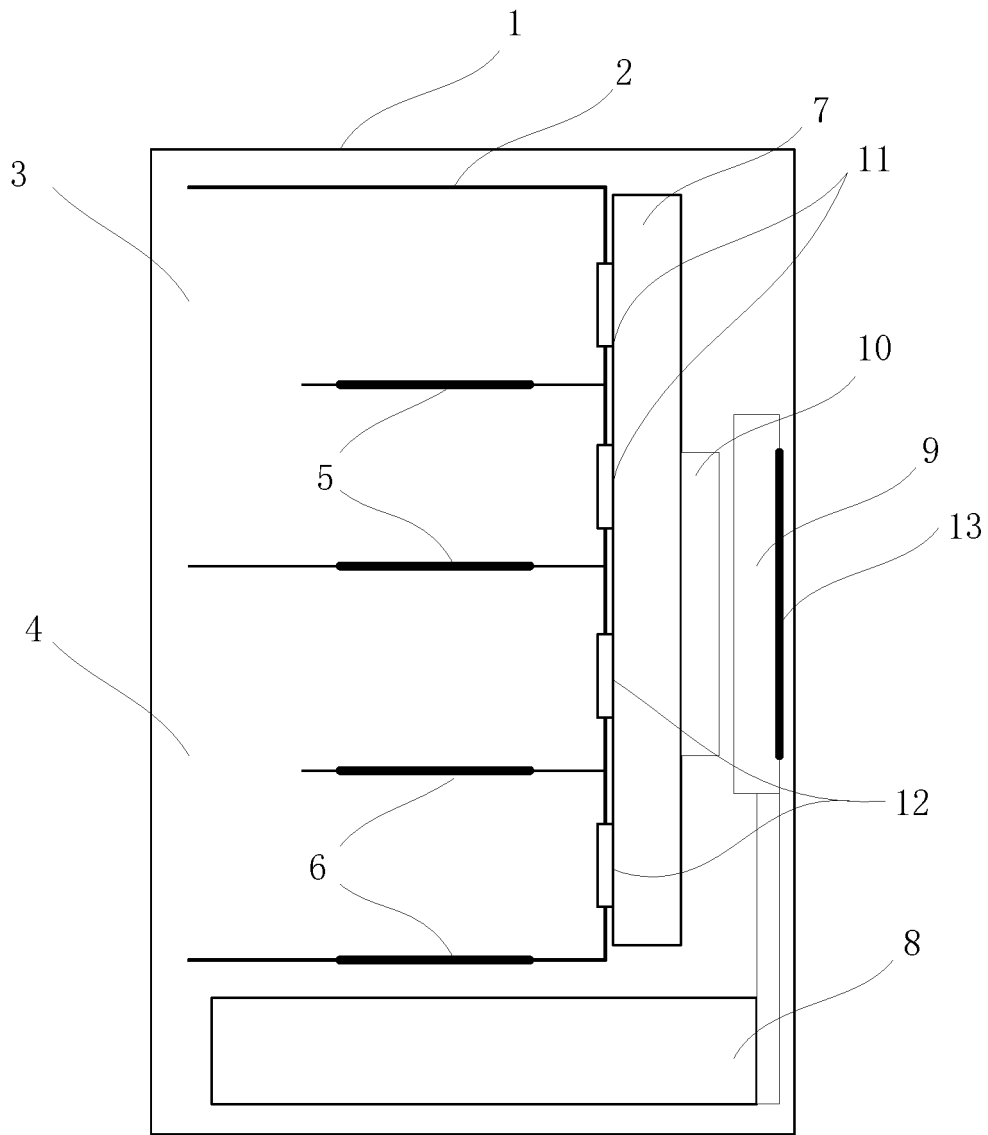

FIG. 1

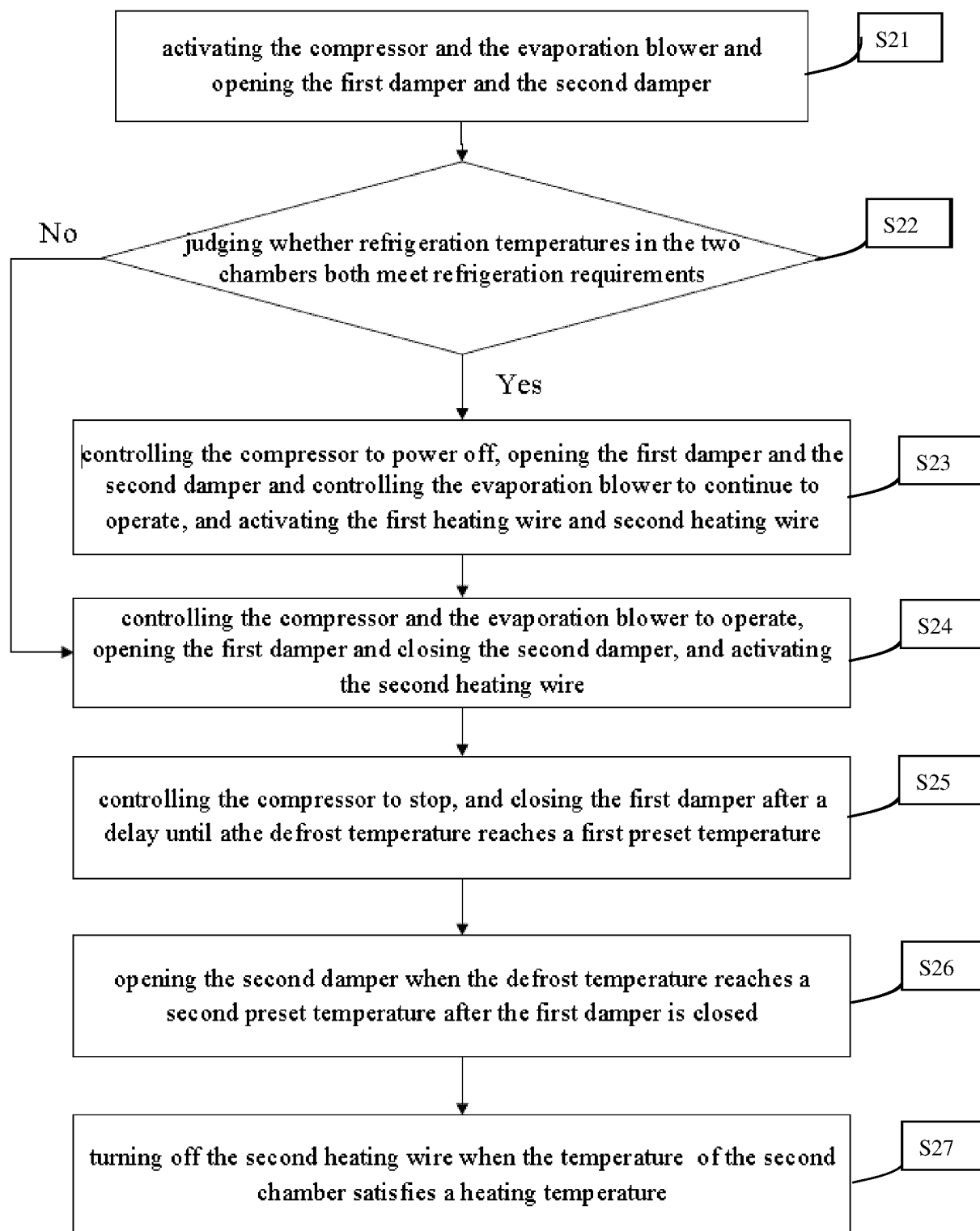

FIG. 2

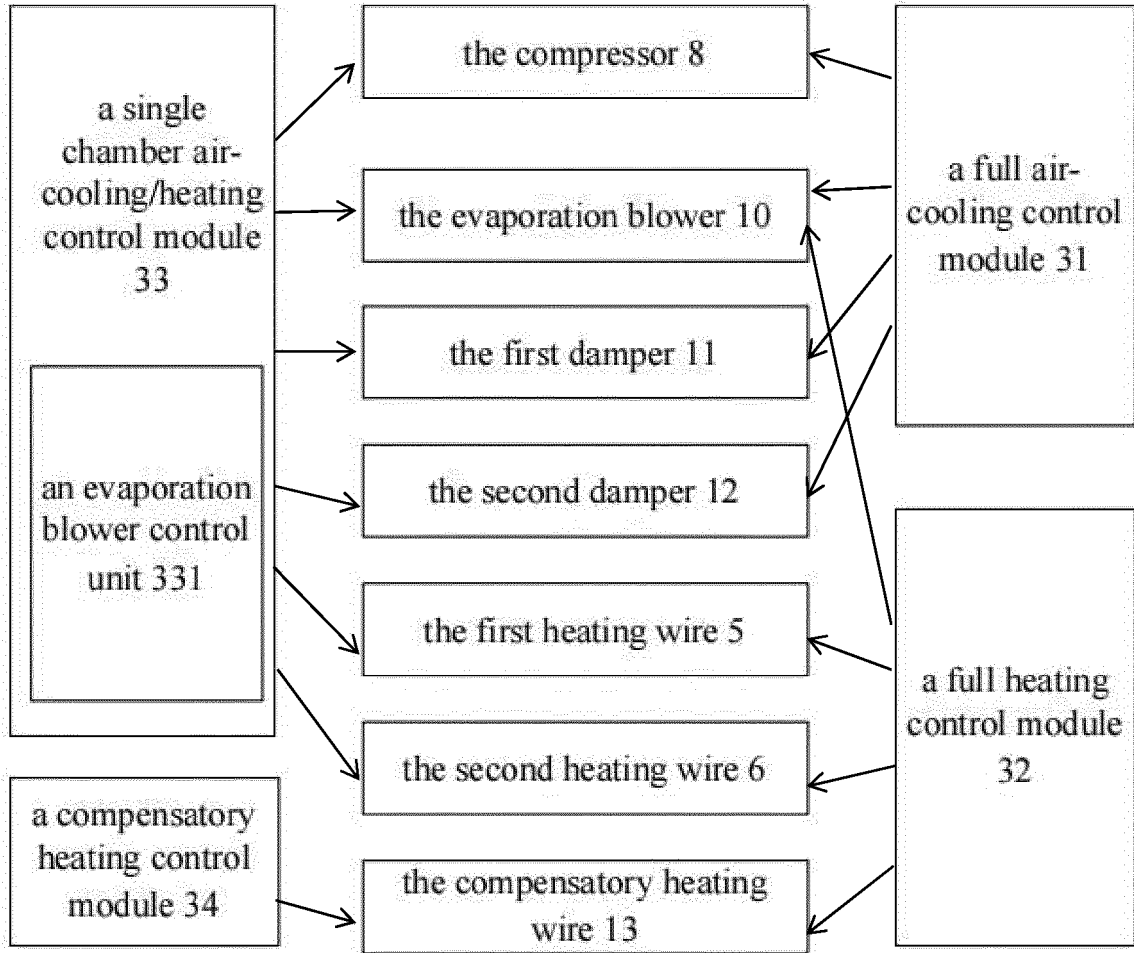

FIG. 3

INTERNATIONAL SEARCH REPORT

International application No.

PCT/CN2020/095499

5	A. CLASSIFICATION OF SUBJECT MATTER F25D 31/00(2006.01)i	
	According to International Patent Classification (IPC) or to both national classification and IPC	
10	B. FIELDS SEARCHED	
	Minimum documentation searched (classification system followed by classification symbols) F25D31/00; F25D17/06; F25D17/00; F25D21/04; F25D29/00	
	Documentation searched other than minimum documentation to the extent that such documents are included in the fields searched	
15	Electronic data base consulted during the international search (name of data base and, where practicable, search terms used) CNABS, CNTXT, CNKL VEN: 风冷, 酒柜, 加热丝, 补偿, 风机, 温度, 风门, 化霜; CABINET, HEAT, WIRE, TEMP, UNIFORM, FAN, DAMPER, DEFROST	
	C. DOCUMENTS CONSIDERED TO BE RELEVANT	
20	Category*	Citation of document, with indication, where appropriate, of the relevant passages
		Relevant to claim No.
	A	CN 109990567 A (QINGDAO HAIER SPECIAL FREEZER CO., LTD. et al.) 09 July 2019 (2019-07-09) description, pages 4-7, and figures 1-5
25	A	CN 209470416 U (QINGDAO HAIER SPECIAL FREEZER CO., LTD.) 08 October 2019 (2019-10-08) description, pages 4-7, and figures 1-8
	A	CN 105352262 A (QINGDAO HAIER CO., LTD.) 24 February 2016 (2016-02-24) entire document
30	A	CN 105486023 A (SUZHOU EAGLE ELECTRIC VEHICLE MANUFACTURING CO., LTD.) 13 April 2016 (2016-04-13) entire document
	A	CN 106839568 A (QINGDAO HAIER CO., LTD.) 13 June 2017 (2017-06-13) entire document
35	A	CN 109751807 A (QINGDAO HAIER SPECIAL FREEZER CO., LTD.) 14 May 2019 (2019-05-14) entire document
	<input type="checkbox"/> Further documents are listed in the continuation of Box C. <input checked="" type="checkbox"/> See patent family annex.	
40	* Special categories of cited documents:	"T" later document published after the international filing date or priority date and not in conflict with the application but cited to understand the principle or theory underlying the invention
	"A" document defining the general state of the art which is not considered to be of particular relevance	"X" document of particular relevance; the claimed invention cannot be considered novel or cannot be considered to involve an inventive step when the document is taken alone
	"E" earlier application or patent but published on or after the international filing date	"Y" document of particular relevance; the claimed invention cannot be considered to involve an inventive step when the document is combined with one or more other such documents, such combination being obvious to a person skilled in the art
45	"L" document which may throw doubts on priority claim(s) or which is cited to establish the publication date of another citation or other special reason (as specified)	"&" document member of the same patent family
	"O" document referring to an oral disclosure, use, exhibition or other means	
	"P" document published prior to the international filing date but later than the priority date claimed	
	Date of the actual completion of the international search 25 August 2020	Date of mailing of the international search report 11 September 2020
50	Name and mailing address of the ISA/CN China National Intellectual Property Administration (ISA/CN) No. 6, Xitucheng Road, Jimenqiao Haidian District, Beijing 100088 China	Authorized officer
55	Facsimile No. (86-10)62019451	Telephone No.

Form PCT/ISA/210 (second sheet) (January 2015)

INTERNATIONAL SEARCH REPORT
Information on patent family members

International application No.
PCT/CN2020/095499

5
10
15
20
25
30
35
40
45
50
55

Patent document cited in search report			Publication date (day/month/year)	Patent family member(s)			Publication date (day/month/year)
CN	109990567	A	09 July 2019	None			
CN	209470416	U	08 October 2019	CN	111351313	A	30 June 2020
CN	105352262	A	24 February 2016	CN	105352262	B	02 April 2019
CN	105486023	A	13 April 2016	None			
CN	106839568	A	13 June 2017	CN	106839568	B	02 August 2019
CN	109751807	A	14 May 2019	CN	109751809	A	14 May 2019
				CN	209470409	U	08 October 2019
				CN	109751810	A	14 May 2019
				CN	109751833	A	14 May 2019
				CN	109990566	A	09 July 2019
				CN	109751811	A	14 May 2019
				CN	109751808	A	14 May 2019
				CN	209386681	U	13 September 2019
				CN	109751832	A	14 May 2019

Form PCT/ISA/210 (patent family annex) (January 2015)