



(51) International Patent Classification:

B65D 5/20 (2006.01) B65D 5/66 (2006.01)
B65D 5/54 (2006.01) B65D 21/02 (2006.01)

(21) International Application Number:

PCT/IB2021/057431

(22) International Filing Date:

12 August 2021 (12.08.2021)

(25) Filing Language:

Italian

(26) Publication Language:

English

(30) Priority Data:

102020000022093 18 September 2020 (18.09.2020) IT

(72) Inventor; and

(71) Applicant: **ROTONDI, Enrico** [IT/IT]; Via Silvio De Sanctis, 31, 03100 Frosinone (IT).

(74) Agent: **DI BERNARDO, Antonio** et al.; c/o Thinx S.r.l., Piazzale Luigi Cadorna, 10, 20123 Milan (IT).

(81) Designated States (unless otherwise indicated, for every kind of national protection available): AE, AG, AL, AM, AO, AT, AU, AZ, BA, BB, BG, BH, BN, BR, BW, BY, BZ, CA, CH, CL, CN, CO, CR, CU, CZ, DE, DJ, DK, DM, DO, DZ, EC, EE, EG, ES, FI, GB, GD, GE, GH, GM, GT, HN, HR, HU, ID, IL, IN, IR, IS, IT, JO, JP, KE, KG, KH, KN, KP, KR, KW, KZ, LA, LC, LK, LR, LS, LU, LY, MA, MD,

ME, MG, MK, MN, MW, MX, MY, MZ, NA, NG, NI, NO, NZ, OM, PA, PE, PG, PH, PL, PT, QA, RO, RS, RU, RW, SA, SC, SD, SE, SG, SK, SL, ST, SV, SY, TH, TJ, TM, TN, TR, TT, TZ, UA, UG, US, UZ, VC, VN, WS, ZA, ZM, ZW.

(84) Designated States (unless otherwise indicated, for every kind of regional protection available): ARIPO (BW, GH, GM, KE, LR, LS, MW, MZ, NA, RW, SD, SL, ST, SZ, TZ, UG, ZM, ZW), Eurasian (AM, AZ, BY, KG, KZ, RU, TJ, TM), European (AL, AT, BE, BG, CH, CY, CZ, DE, DK, EE, ES, FI, FR, GB, GR, HR, HU, IE, IS, IT, LT, LU, LV, MC, MK, MT, NL, NO, PL, PT, RO, RS, SE, SI, SK, SM, TR), OAPI (BF, BJ, CF, CG, CI, CM, GA, GN, GQ, GW, KM, ML, MR, NE, SN, TD, TG).

Declarations under Rule 4.17:

— of inventorship (Rule 4.17(iv))

Published:

— with international search report (Art. 21(3))
— in black and white; the international application as filed contained color or greyscale and is available for download from PATENTSCOPE

(54) Title: MODULAR CONTAINER WITH LID

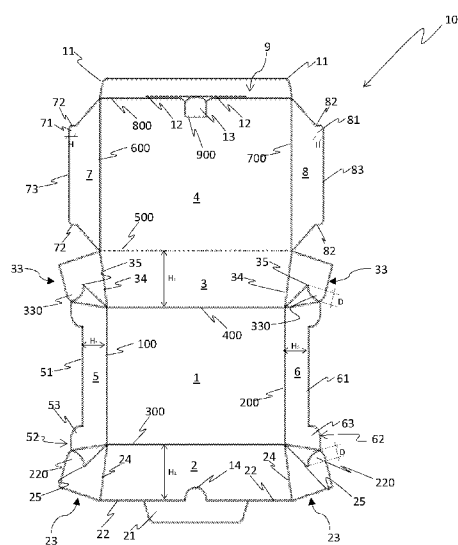

Fig.1

(57) Abstract: The present invention relates to a modular container (10) that can be erected starting from a single punched element, comprising a bottom panel (1) of a quadrangular shape from whose sides respectively develop a front panel (2), a rear panel (3), a first lateral panel (5) and a second lateral panel (6), wherein the front panel (2) has a front edge (22) from which an extension element (21) protrudes. The modular container (10) comprises a lid panel (4) comprising a transversal band (9) in extension from one side of the lid panel (4) along the base of which there is a notch (12) suitable for accommodating said extension element (21), in an assembled and closed configuration of the container (10). A first tab (14) is formed by means of notch, in correspondence with an edge portion of the front panel (2), and is configured to be rotatable about an axis substantially coinciding with the front edge (22). The notch (12) forms a second tab (13) on the body of the lid panel (4), yieldably connected to the lid panel (4) by means of a weakening line (900); in the assembled and closed configuration of the modular container (10) the first tab (14) is at least partially superimposed on the second tab (13) so as to form a grip able to bring the modular container (10) from a closed assembled configuration to an open assembled configuration, pushing said tabs (13, 14) away from each other.



- 1 -

MODULAR CONTAINER WITH LID**DESCRIPTION****TECHNICAL FIELD**

The present invention refers to the field of closable packaging and containers. In particular, the invention relates to a modular container provided with a lid.

BACKGROUND ART

In the packaging sector, with particular regard to containers intended to house objects of various kinds, including food articles in particular, the use of containers made starting from cardboard blanks is widely used which, suitably assembled together, will constitute a box-like body in which the object to be protected and/or transported can be received.

In the remainder of this description, "lid" means an element suitable for closing the upper opening of the container.

10 The expression "stacked containers" means two or more stacked containers, arranged to form a stack.

The expression "assembled and open configuration of the container" means a configuration in which the main body of the modular container is mounted, without lid.

15 The expression "assembled and closed configuration of the container" means a configuration in which the main body of the modular container is mounted accompanied by a lid closed on it.

20 Generally, the box-like body is made by folding and subsequent coupling of the elements resulting from punching, by means of a succession of reciprocal joints and subsequent gluing, or mechanical anchoring by stapling some parts, these consolidation operations being necessary to ensure the robustness of the container that is thus formed.

25 Said process involves a certain complexity in the management of the different elements that make up the container, both from the point of view of processing - having several steps to be managed to make different elements - and of subsequent assembly, in view of the time taken to complete the consolidation operations. The gluing or mechanical anchoring operations also entail constraints between the various parts of a substantially permanent type and therefore, once the box-like body has been assembled, it becomes impossible to unfold it flat (for example in order to store the cardboard for

- 2 -

subsequent use) without causing at least partial damage to the structure thereof.

A further type of containers of the box-like type, suitable for containing and transporting foods of various kind, involves the assembly of a single cardboard obtained by punching, configured so that the different parts of which it is made up can be suitably
5 folded and connected to each other so as to create the final container. The containers obtained by means of such solutions, however, are less resistant to both internal (e.g. due to the weight of the objects contained therein) and external stresses than containers in which some parts are consolidated by gluing or other additional constraints, as described above.

10 To overcome this problem, the punched cardboard elements can be shaped in such a way that they are provided with a large number of parts which, through mutual coupling, can constitute additional reinforcing elements to the container structure. However, the assembly of this type of box-like element also involves an increase in the user's set-up time, as a large number of parts need to be firmly coupled together in order
15 to provide adequate support and protection for the products that will be placed inside the container.

With regard to the containers intended for containing foodstuffs, it is also of particular importance to be able to use them easily, both in the operations of introducing the foods inside the container, and in being able to easily provide for a rapid opening of
20 the container in order to easily use the contents.

Furthermore, the punched cardboards that make up the final containers are typically made available in an unfolded form, i.e. planar, for ease of handling and transport in multiple units gathered in packages; each punched part is then assembled on site by a user, forming a tray element connected to a lid element in an open
25 configuration. These operations are not practically feasible in the case of the solution involving the consolidation of the structure by means of gluing/additional constraints since, as mentioned, its flat unfolding would entail at least a partial damage to its structure; even the solution that includes mounting the container starting from a single punched cardboard, however, does not allow a rapid unfolding just because of the high
30 number of connection constraints between the various parts that must be disconnected.

The Applicant has therefore felt the need to make a box-shaped container provided with a lid that is easy to use.

OBJECTS AND SUMMARY OF THE INVENTION

An object of the present invention is to overcome the drawback of the prior art.

- 3 -

In particular, it is an object of the present invention to present a self-mounting modular container provided with a lid element, which is easy to manufacture and use, while maintaining robustness and durability over time.

5 Furthermore, it is an object of the present invention to realise a modular container provided with an improved opening system from a closed configuration to an open configuration, and which at the same time allows to preserve the content housed therein, during such operations of opening the container.

A further object of the present invention is to realise a modular container provided with a lid element which can be easily erected starting from a single punched element.

10 A further object of the present invention is to present a modular container provided with a lid element, the shape of which allows for a rapid stacking of several containers in a contained space, when such containers are arranged in an open configuration.

15 A further object of the present invention is also to present a self-mounting modular container which can be easily unfolded flat, so as to allow optimal storage for further use and/or disposal thereof.

Finally, it is an object of the present invention to present a self-mounting modular container which can be manufactured in a cost-effective manner with respect to containers of the prior art.

20 These and other objects of the present invention are achieved by means of a modular container incorporating the features of the appended claims, which form an integral part of the present description.

25 According to a first aspect, the present invention relates to a modular container that can be erected starting from a single punched element, comprising a bottom panel of quadrangular shape from whose sides respectively develop a front panel, a rear panel, a first lateral panel and a second lateral panel wherein the front panel has a front edge from which an extension element protrudes. The modular container further comprises a lid panel comprising a transversal band extending from one side of the lid panel along the base of which there is a notch suitable for accommodating said extension element, in
30 an assembled and closed configuration of the container. At an edge portion of the front panel a first tab is formed by notching, configured to be rotatable about an axis substantially coinciding with the front edge. The notch forms a second tab on the body of the lid panel, yieldably connected to the lid panel by means of a weakening line. In the assembled and closed configuration of the modular container, the second tab is at least
35 partially superimposed on the first tab so as to form a grip able to bring the modular

- 4 -

container from a closed assembled configuration to an open assembled configuration, pushing said tabs away from the other.

According to this solution, a container is realised which is easy to mount and to use and is furthermore very robust. In particular, gripping elements are advantageously made available in a simple and cost-effective way, which allow a user to easily open the container, guaranteeing the preservation of the content housed in the container during the opening operations thereof.

The present invention in at least one of the aforesaid aspects may have at least one of the following preferred features, taken individually or in combination with any other one of the preferred characteristics described.

Preferably, the first and second lateral panels have a substantially trapezoidal shape with a short base which extends respectively along a first and a second fold line corresponding to two opposite sides of said bottom panel, said first and second lateral panels have a shaped edge, in a position opposite to this short base, which comprises a central portion substantially parallel to the first fold line and two side portions, each of which extends from the respective ends of the first central portion defining protruding flaps.

According to a preferred embodiment, the front panel and the rear panel are connected to respective pairs of lateral extensions, each comprising a hook element including a recess and an elongated portion which extends from this recess and has a length D whose value is greater than or equal to about 10 mm, said hook element being configured to engage with the protruding flaps of the first and second lateral panels so as to make a joint, in an assembled configuration of the container.

Preferably, the lid panel comprises a first lateral band and a second lateral band of trapezoidal shape which extend from opposite sides of the lid panel. The first and second lateral bands have respectively a first end flap and a second end flap which are adapted to engage the respective central portions of the first and second lateral panels in an assembled and closed configuration of the container, said first and second end flaps having a substantially rectangular shape of height H whose value is greater than or equal to about 5 mm and less than or equal to about 30 mm. Preferably the first and second end flaps have a height H whose value is less than or equal to about 20 mm.

In this way, the modular container can be quickly erected and brought into an assembled configuration; thanks to its particular shape, obtained by optimising the number and the reciprocal position of the elements that make it up, it also allows to have a high stability and robustness, even after its reuse.

- 5 -

Preferably, the front edge extends for a length L and the extension element has a trapezoidal shape whose long base coincides with at least a portion of said front edge and has a length l equal to at least 40% of the length L .

5 According to this configuration, the stability of the modular container is increased, during the closed assembled configuration, as the connection between the front panel and the lid panel through the connection between the connecting element and the notch, is made for a good part of the upper side of the lateral panel, that is the front edge; moreover, the particular trapezoidal shape of the extension element, allows an easier insertion of the connecting element inside the notch, facilitating and consequently
10 speeding up the assembly operations of the container.

Preferably, the transversal band is connected to the lid panel by means of a longitudinal fold line in longitudinal extension along the entire dimension of the side of the lid panel, and in which the notch is made in a central portion of the longitudinal fold line, extending for a maximum of 70% of its length.

15 According to this configuration, the container structure is further strengthened since there is a closure element, that is the lateral band, on which the stresses are distributed in an optimal way. The appropriate sizing of the notch further optimally ensures the stability of the closure constraint obtained by the connection between the connecting element and the notch itself, suitably avoiding weakening the structure of the
20 container.

Preferably, the front panel has a substantially trapezoidal shape, with a short base coinciding with a third fold line and having a height H_2 .

Preferably, the rear panel has a substantially trapezoidal shape, with a short base coinciding with a fourth fold line and having a height H_3 .

25 Preferably, the value of height H_2 is substantially equal to the value of height H_3 .

Preferably, the front panel, the rear panel, the first lateral panel and the second lateral panel are inclined at an angle between about 95° and about 120° with respect to the bottom panel when the modular container is in an assembled configuration.

30 According to this preferred configuration, the modular container advantageously has flared walls which extend starting from the bottom panel, ensuring an optimisation of opening shape thus created so that, in the assembled and open configuration, a stack of modular containers that are arranged one partially inside the other can be formed. Advantageously, in fact, the flared shape of the walls facilitates the slid of the surfaces of the containers in contact with each other, so as to improve the extraction action of a

- 6 -

container placed in an upper position, from the one placed below it.

Preferably, the bottom panel of a container placed in an upper position, in a stack of containers in an assembled and open configuration, is located at a distance of at least 3 mm from the bottom panel of the container below it.

5 In this way the integrity of the underlying container is preserved, as well as the extraction of the container placed above is facilitated.

Preferably, the central portion of the shaped edge of the first lateral panel is placed at a distance H_5 with respect to the first fold line and the central portion of the shaped edge of the second lateral panel is placed at a distance H_6 with respect to the second fold
10 line and the length D of the elongated portions has a value lower than the value of height H_5 and height H_6 .

Preferably, the height H of the first and second end flaps has a value of less than 40% of the value of height H_5 and height H_6 . According to a preferred configuration, the height H of the first and second end flaps has a value of less than 30% of the value of the
15 height H_5 and height H_6 .

According to this configuration, an excellent balance is ensured between the need to ensure the stability of the constraints that ensure the closure of the container, and the need to have a container that is easy to open starting from an assembled and closed configuration.

20 Preferably, the height H of the first end flap and the second end flap is less than or equal to about 30 mm.

According to this configuration, unwanted interferences with the content of the container itself are advantageously avoided.

Preferably, the height H of the first end flap and the second end flap has a value
25 greater than or equal to about 5 mm.

This ensures a stable anchoring of the lateral panels to the container structure.

Preferably, the lid panel is connected to the rear panel by means of a fifth fold line which consists of a fracture line obtained by perforating the punched cardboard by means of which said modular container is made.

30 According to this embodiment, it is advantageously possible to separate the lid panel from the rear panel to create a tray-like container. This configuration is extremely advantageous when, for example, the modular container is used to contain foodstuffs, as

- 7 -

the foods can be transported and/or protected inside the container in a closed configuration and then conveniently enjoyed by means of the tray created.

Further features and advantages of the present invention will be more apparent from the description of the accompanying drawings.

BRIEF DESCRIPTION OF THE DRAWINGS

5 The invention will be described below with reference to some examples, provided for explanatory and non-limiting purposes, and illustrated in the accompanying drawings. These drawings illustrate different aspects and embodiments of the present invention and, where appropriate, reference numerals illustrating similar structures, components, materials and/or elements in different figures are indicated by similar
10 reference numbers.

Figure 1 shows a plan view of a container according to an embodiment of the present invention in an unfolded configuration;

Figures 2a to 2e show the container of Figure 1 in some steps of its construction. In detail:

15 Figure 2a shows, schematically and in perspective view, the container of Figure 1 in an unfolded configuration;

Figure 2b shows, schematically and in perspective view, the container of Figure 1 in a first mounting step;

20 Figure 2c shows, schematically and in perspective view, the container of Figure 1 in a second mounting step;

Figure 2d shows, schematically and in perspective view, the container of Figure 1 in a third mounting step;

Figure 2e shows, schematically and in perspective view, the container of Figure 1 in an assembled and open configuration;

25 Figure 3 shows, schematically and in perspective view, a plurality of containers according to the invention, assembled and in open configuration, stacked on top of each other to form a stack;

Figures 4a to 4d show the container according to the invention in further steps of its construction, in detail:

30 Figure 4a shows, schematically and in perspective view, a first step of mounting

- 8 -

the container lid assembled according to the invention;

Figure 4b shows, schematically and in perspective view, a second step of mounting the assembled container lid of Figure 2g;

5 Figure 4c shows, schematically and in perspective view, a third step of mounting the container lid according to the invention; and

Figure 4d shows, schematically and in perspective view, a step of mounting the container, in order to obtain an assembled container and in a closed configuration according to the invention.

DETAILED DESCRIPTION OF THE INVENTION

10 While the invention is susceptible to various modifications and alternative constructions, certain preferred embodiments are shown in the drawings and are described hereinbelow in detail. It is in any case to be noted that there is no intention to limit the invention to the specific embodiment illustrated, rather on the contrary, the invention intends lid all the modifications, alternative and equivalent constructions that fall within the scope of the invention as defined in the claims.

15 The use of "for example", "etc.", "or" indicates non-exclusive alternatives without limitation, unless otherwise indicated. The use of "includes" means "includes, but not limited to", unless otherwise indicated.

With reference to Figures 1-4d, 10 collectively denotes as a modular container provided with lid according to the present invention.

20 The modular container 10 is obtained starting from an element made as a single body by punching, generally made of cardboard or the like, which comprises all the elements necessary to constitute the modular container 10 itself.

25 The container 10 comprises a bottom panel 1, preferably of quadrangular shape, from which a front panel 2 and a rear panel 3 extend. The container 10 further comprises a first lateral panel 5 and a second lateral panel 6 which extend, in opposite positions, from the bottom panel 1 and which are connected thereto by means of a first fold line 100 and a second fold line 200, respectively.

30 Preferably, the first lateral panel 5 and the second lateral panel 6 have a substantially equivalent shape, therefore in the following description reference will be made to the characteristics of the first lateral panel 5, it being understood that similar considerations apply further to the characteristics of the second lateral panel 6.

- 9 -

In a preferred embodiment, the first lateral panel 5 has a substantially trapezoidal shape, with a short base coinciding with the first fold line 100, and has a shaped edge in a position opposite to said short base. Preferably, the shaped edge has a central portion 51 substantially parallel to the first fold line 100 and two side portions 52, each of which extends in an arched profile from the respective ends of the first central portion 51; according to this shape, two protruding flaps 53 are thus defined on the lateral ends of the lateral panel 5, having a rounded profile. Similar protruding flaps 63 are defined on the second lateral panel 6.

Preferably, the central portion 51 of the shaped edge of the first lateral panel 5 is placed at a distance H_5 with respect to the first fold line 100 and the central portion 61 of the shaped edge of the second lateral panel 6 is placed at a distance H_6 with respect to the second fold line 200; according to a preferred embodiment of the container 10, the value of the distance H_5 is substantially equal to the value of the distance H_6 .

Preferably the front panel 2 has a substantially trapezoidal shape, with a short base coinciding with a third fold line 300 and a height H_2 . The front panel 2 further has a front edge 22 of length L , from which an extension element 21 of trapezoidal shape protrudes, whose long base coincides with at least a portion of said front edge 22. According to a preferred configuration of the modular container according to the invention, the long base of the extension element 21 has a length l equal to at least 40% of the length L of the front edge 22.

A first tab 14 is formed by means of notch, on the front panel 2, in correspondence with an edge portion thereof, and is configured to be rotatable about a rotation axis substantially coinciding with the front edge 22. According to a preferred configuration, the first tab 14 is positioned on the centreline of the front edge 22.

Preferably also the rear panel 3 is shaped according to a substantially trapezoidal shape, with a short base coinciding with a fourth fold line 400 and with height H_3 .

According to a preferred embodiment of the invention, the first fold line 100, the second fold line 200, the third fold line 300 and the fourth fold line 400 make up the sides of the bottom panel 1. Preferably, the front panel 2 and the rear panel 3 have a trapezoidal shape having similar dimensions, so that the value of height H_2 is substantially equal to that of height H_3 .

The specific trapezoidal shape of the front panel 2, the rear panel 3, the first lateral panel 5 and the second lateral panel 6 means that, when the modular container is in an assembled conformation, they are arranged so as to form an angle greater than 90° with respect to the bottom panel 1 (as visible, for example, in Figure 2e). Preferably, the front panel 2, the rear panel 3, the first lateral panel 5 and the second lateral panel 6 are inclined

- 10 -

at an angle between about 95° and about 120° with respect to the bottom panel 1, when the modular container 10 is in an assembled configuration.

5 The modular container 10, in an assembled configuration, therefore, has flared walls that extend starting from the bottom panel 1; this characteristic guarantees an optimisation of the opening shape that is created so as to allow, in an assembled and open configuration, the formation of a stack of modular containers 10 arranged one partially inside the other. Advantageously, in fact, the insertion of a container 10 into the opening of a further container 10 positioned below it, is facilitated thanks to the flaring.

10 In the stacked configuration, as shown in Figure 3, the bottom panels 1 of the various stacked modular containers 10 are arranged parallel to each other; preferably the bottom panel 1 of the container 10 placed in the upper position is at a distance of at least 3 mm from the bottom panel 1 of the container below it. In this way, it is advantageously possible to create a stack of modular containers 10, with a considerable saving in the space occupied by them, for example when a user is waiting to use them.

15 Further, in the case where the container is arranged in a closed assembled configuration, the volume created inside the modular container 10 is conveniently enlarged, allowing objects of various shapes to be housed, as well as an advantageous increase in the circulation of air inside the container itself, useful for example in the case in which the container 10 is used to accommodate articles subject to perishability.

20 The flared shape of the walls also facilitates the slid of the surfaces of the containers that are in contact with each other, thus improving the action of extracting a container placed in an upper position from one placed below it.

The modular container 10 further has a lid panel 4, connected to the rear panel 3 by means of a fifth fold line 500, and preferably having a quadrangular shape, similar to that of the corresponding bottom panel 1. In a preferred embodiment, the lid panel 4 and the bottom panel have a rectangular shape. The lid panel 4 has a first lateral band 7, joined thereto by means of a sixth fold line 600, as well as a second lateral band 8, joined thereto by means of a seventh fold line 700. Preferably, the first lateral band 7 and the second lateral band 8 are substantially configured according to an isosceles trapezoid, having a long base coinciding with the respective fold lines 600, 700.

35 According to a preferred embodiment of the invention, the first lateral band 7 has a first end flap 71 of substantially rectangular shape in extension therefrom and whose height H preferably has a value less than or equal to about 5 mm and greater than or equal to at least about 30 mm. More particularly, the two short sides 72 of the end flap 71 are connected to the outer edge of the first lateral band 7, extending from the latter in a direction substantially perpendicular to the sixth fold line 600. The end flap 71 further

- 11 -

has a base 73, which is joined to said short sides 72 at their ends according to curved connecting lines, and which is arranged in a direction substantially parallel to the sixth fold line 600. According to a preferred configuration, the height H of the end flap 71 has a value of less than 40% of the value of the distance H_5 , even more preferably less than 5 30%.

According to a preferred embodiment of the invention, the first lateral band 8 has a second end flap 81 of substantially rectangular shape in extension from the same and whose height H preferably has a value less than or equal to about 5 mm and greater than or equal to at least about 30 mm. More particularly, the two short sides 82 of the second end flap 81 are connected to the outer edge of the first lateral band 8, extending from the 10 latter in a direction substantially perpendicular to the seventh fold line 700. The second end flap 81 further has a base 83, which is joined to said short sides 82 at their ends according to curved connecting lines, and which is arranged in a direction substantially parallel to the seventh fold line 700. According to a preferred configuration, the height H 15 of the second end flap 81 has a value of less than 40% of the value of the distance H_6 , even more preferably less than 30%.

In a preferred embodiment the fifth fold line 500 consists of a fracture line obtained by perforating the punched cardboard; thanks to this feature, it is possible to easily separate the lid panel 4 from the rear panel 3, so as to create a tray-like container. This 20 configuration is extremely advantageous when, for example, the modular container is used to contain foodstuffs, as the foods can be transported and/or protected inside the container in a closed configuration and then conveniently enjoyed by means of the tray created.

According to the invention, the lid body 4 is provided with a transversal band 9, 25 preferably of trapezoidal shape with outer edges 11 having preferably a rounded profile. The transversal band 9 extends from the lid panel 4 substantially through the entire transversal extension thereof, along a longitudinal fold line 800 by means of which it is connected to the lid panel 4. Preferably, the transversal band 9 has a longitudinal extension substantially equal to the dimension of the side of the lid panel 4 to which it is 30 connected, i.e., to the longitudinal fold line 800. This configuration advantageously gives stability to the connection between lid panel 4 and front panel 2, in the assembled and closed configuration of the modular container 10.

According to a preferred configuration, between the transversal band 9 and the lid panel 4, there is a notch 12 which partially extends along said longitudinal fold line 800, 35 forming a second shaped tab 13 from the body of the lid panel 4, and yieldingly connected to the lid panel 4 itself by means of a weakening line 900. In a preferred configuration, the second tab 13 is positioned on the centreline of the longitudinal fold line 800.

- 12 -

Preferably, the notch 12 is formed in a central portion of the longitudinal fold line 800, extending for a maximum of 70% of its length of the longitudinal fold line 800. According to this configuration, an optimal yielding is ensured to the transversal band 9, as it is sufficient for an easy handling by a user, and at the same time determining an adequate robustness to the structure as well as a resistance over time.

Preferably, the front panel 2 and the rear panel 3 are connected to respective pairs of lateral extensions 23, 33, which extend starting from the sides of these panels.

According to a preferred configuration, the lateral extensions 23 of the front panel 2 each comprise a hook element including a recess 25 and an elongated portion 220 which extends from this recess 25 and having a curved shaped profile. Preferably, the hook element is shaped so that the length D of the elongated portion 220 which extends from the recess 25 has a value equal to at least 10 mm. Preferably the length D has a value less than the height H_5 and even more preferably less than about 40% of the value of height H_5 .

Similarly, the lateral extensions 33 of the rear panel 3 each comprise a hook element including a recess 35 and an elongated portion 330 which extends from this recess 35 and having a curved shaped profile. Preferably, the hook element is shaped so that the length D of the elongated portion 330 which extends from the recess 35 has a value equal to at least 10 mm. Preferably the length D has a value less than the height H_6 and even more preferably less than about 40% of the value of height H_6 .

According to the present invention, mounting the modular container 10 involves the initial unfolding along a plane of the punched cardboard that will compose it (see fig. 2a).

Starting from this punched cardboard, in a first mounting step the front panel 2 is folded along the third fold line 300 and the rear panel 3 along the fourth fold line 400; in this phase the first lateral panel 5 is folded along the first fold line 100 and the second lateral panel 6 is folded along the second fold line 200 (see fig. 2b where this movement is indicated by appropriate arrows).

In a second mounting step, as shown in Figure 2c, the lateral extensions 23 of the front panel 2, as well as the lateral extensions 33 of the rear panel 3, are rotated around their respective hinge lines 24, 34, towards the lateral panels 5, 6 until they are close to the latter.

In a third mounting step, as shown in Figure 2d, the elongated portions 220 of the lateral extensions 23, as well as the elongated portions 330 of the lateral extensions 33 of the rear panel 3, are brought close to the respective lateral panels 5,6.

- 13 -

In the fourth mounting step, as shown in Figure 2e, the elongated portions 220, 330 are pushed along a direction substantially perpendicular to the bottom panel 1 of the container 10, in correspondence with the central portions 51, 61 of their shaped edges so as to couple them interlockingly to the protruding flaps 53, 63. The special shape of the hook element, in particular the presence of the recess 25, allows obtaining a stable anchoring of the lateral extensions 23, 33 to the respective lateral panels 5,6.

In this way, a constraint is achieved, in a simple and easy-to-make manner, that prevents the mutual separation of these elements, thus guaranteeing the stability of the modular container 10 in the reached open assembled configuration.

From this assembled and open configuration, the lid panel 4 can be rotated around the fifth fold line, as shown in Figure 4a, in the direction of the front panel 2.

In a second step of mounting the lid panel 4, as shown in Figure 4b, the lid panel 4 is further rotated towards the front panel 2, and the transversal band 9 is folded so as to insert the extension member 21 inside the notch 12. In this configuration, the extension element 21 is substantially coplanar to the lid panel 4 and the transversal band 9 is in contact with an inner portion of the front panel 2.

In a third step of mounting the lid panel 4 of the modular container 10, as shown in Figure 4c, the first lateral band 7 and the second lateral band 8, are rotated downwards around the respective fold lines 600, 700 and the front panel 2 can be further pushed in the direction of the notch 12, so as to further stabilise the structure thus obtained. In such a configuration, the second tab 13 is superimposed on the first tab 14, or partially superimposed thereon, so as to form a sort of grip by means of which a user can easily open the modular container, i.e. bringing it from a closed assembled configuration to an open assembled configuration, by simply pushing said tabs 13, 14 away from each other.

In a fourth step of mounting the lid panel 4, as shown in Figure 4d, the first lateral band 7 and the second lateral band 8 are pushed towards the lateral panels 5, 6 until inserting the end flap 71 and the end flap 81 into the joint made previously (mounting step) between the gripping fins 220, 330 and the protruding flaps 53, 63 of the lateral panels; more particularly, the end flaps 71, 81 are inserted into said joint in correspondence with the central portions 51, 61 of the shaped edges of the first and second lateral panels 6, 7.

The container 10 is advantageously used for a wide range of purposes, in particular related to housing and transporting food products, as it is provided with a structure that is simple to mount and to dismantle, so as to allow its flat unfolding for an easier positioning of the foods inside.

- 14 -

The container is also advantageously suited to house articles that can be easily damaged, such as soft cakes, as the flared shape of the container's lateral walls makes it easier to insert them, preventing them from being damaged.

5 Also, the particular shape as well as the dimensioning of the height H of the first end flap 71 and of the second end flap 81, allows creating the anchorage of the lateral panels 5, 6 to the structure of the container, avoiding undesired interferences with the content present in the container itself.

10 The modular container 10 can be advantageously customisable based on the various uses to which it can be destined. The punched element with which the container 10 is made allows in fact realising a partial or total lid of its surfaces in a simple and economical way, so as to confer specific functional characteristics to the container itself, such as, for example, impermeability or resistance to heat or even insulation of the modular container 10.

15 The outer surfaces can also be easily decorated by printing or by affixing adhesive elements, allowing the container to be customised.

The invention thus conceived is susceptible to several modifications and variations, all falling within the scope of protection defined by the appended claims.

20 For example, the modular container 10 is made of plastic material, including transparent one, e.g. PVC, so that the content can be viewed, which is useful in the event of checks or for an easy display of the articles inside the container.

According to an alternative embodiment, moreover, the first and second lateral panels 5, 6, the front panel 2 and the rear panel 3 have a substantially rectangular shape and are inclined according to an angle of about 90° with respect to the rear panel 1.

25 Further, the lid panel 4 may advantageously comprise through-holes for inserting cords, strips or the like, so as to create a gripping element, in the form of a grip, for transporting the modular container 10, when it is in an assembled and closed configuration.

30 Moreover, all the details can be replaced by other technically equivalent elements. In practice, the materials used, as well as the contingent shapes and sizes, can be whatever according to the requirements without for this reason departing from the scope of protection of the following claims.

- 15 -

CLAIMS

1. Modular container (10) that can be erected starting from a single punched element, comprising a bottom panel (1) of quadrangular shape from whose sides respectively develop a front panel (2), a rear panel (3), a first lateral panel (5) and a second lateral panel (6), wherein the front panel (2) has a front edge (22) from which an extension element (21) protrudes;
- 5 said modular container (10) further comprising a lid panel (4) comprising a transversal band (9) in extension from one side of the lid panel (4) along the base of which there is a notch (12) suitable for accommodating said extension element (21), in an assembled and closed configuration of the container (10); wherein
- 10 - a first tab (14) is formed by means of notch, in correspondence with an edge portion of the front panel (2), and is configured to be rotatable about an axis substantially coinciding with the front edge (22);
- the notch (12) forms a second tab (13) on the body of the lid panel (4), yieldably connected to the lid panel (4) by means of a weakening line (900); and in which
- 15 in the assembled and closed configuration of the modular container (10) the first tab (14) is at least partially superimposed on the second tab (13) so as to form a grip able to bring the modular container (10) from a closed assembled configuration to an open assembled configuration, pushing said tabs (13, 14) away from each other.
- 20 2. Modular container (10) according to claim 1, wherein:
- the first and second lateral panels (5, 6) have a substantially trapezoidal shape with a short base which extends respectively along a first and a second fold line (100, 200) corresponding to two opposite sides of said bottom panel (1), said first and second lateral panels (5, 6) have a shaped edge, in a position opposite to this short base, which
- 25 comprises a central portion (51, 61) substantially parallel to the first fold line (100, 200) and two side portions (52, 62), each of which extends from the respective ends of the first central portion (51, 61) defining protruding flaps (53, 63); and wherein
- the front panel (2) and the rear panel (3) are connected to respective pairs of lateral extensions (23, 33), each comprising a hook element including a recess (25, 35) and an elongated portion (220, 330) which extends from this recess (25, 35) and has a length D whose value is greater than or equal to about 10 mm, said hook element being configured to engage with the protruding flaps (53, 63) of the first and second lateral panels (5, 6) so as to make a joint, in an assembled configuration of the container (10).
- 30
3. Modular container (10) according to claim 1, wherein:
- 35 the lid panel (4) comprises a first lateral band (7) and a second lateral band (8) of trapezoidal shape which extend from opposite sides of the lid panel (4); and wherein

- 16 -

- 5 said first and second lateral bands (7, 8) have respectively a first end flap (71) and a second end flap (81) which are apt to engage the respective central portions (51, 61) of the first and second lateral panels (5, 6) in an assembled and closed configuration of the container (10), said first and second end flaps (71, 81) having a substantially rectangular shape of height H whose value is greater than or equal to about 5 mm and less than or equal to about 30 mm.
4. Modular container (10) according to any one of claims 1 to 3, wherein the front edge (22) extends for a length L and the extension element (21) has a trapezoidal shape whose long base coincides with at least a portion of said front edge (22) and has a length l equal to at least 40% of the length L.
- 10
5. Modular container (10) according to any one of claims 1 to 4, wherein the transversal band (9) is connected to the lid panel (4) by means of a longitudinal fold line (800) in longitudinal extension along the entire dimension of the side of the lid panel (4), and in which the notch (12) is made in a central portion of the longitudinal fold line (800),
- 15 extending for a maximum of 70% of its length.
6. Modular container (10) according to claim 1, wherein:
- the front panel (2) has a substantially trapezoidal shape, with a short base coinciding with a third fold line (300) and having a height H_2 ;
 - the rear panel (3) has a substantially trapezoidal shape, with a short base coinciding with a fourth fold line (400) and having a height H_3 ; and wherein
- 20 the front panel (2), the rear panel (3), the first lateral panel (5) and the second lateral panel (6) are inclined at an angle between about 95° and about 120° with respect to the bottom panel (1), when the modular container (10) is in an assembled configuration.
7. Modular container (10) according to any one of claims 2 to 6, wherein the central portion (51) of the shaped edge of the first lateral panel (5) is placed at a distance H_5 with respect to the first fold line (100) and the central portion (61) of the shaped edge of the second lateral panel (6) is placed at a distance H_6 with respect to the second fold line (200) and in which the length D of the elongated portions (220, 330) has a value lower than the value of height H_5 and height H_6 .
- 25
8. Modular container (10) according to claim 7, in which the height H of the first and second end flaps (71, 81) has a value of less than 40% of the value of height H_5 and height H_6 .
- 30
9. Modular container (10) according to any one of the preceding claims, wherein the lid panel (4) is connected to the rear panel (3) by means of a fifth fold line (500) which consists of a fracture line obtained by perforating the punched cardboard by means of
- 35 which said modular container (10) is made.

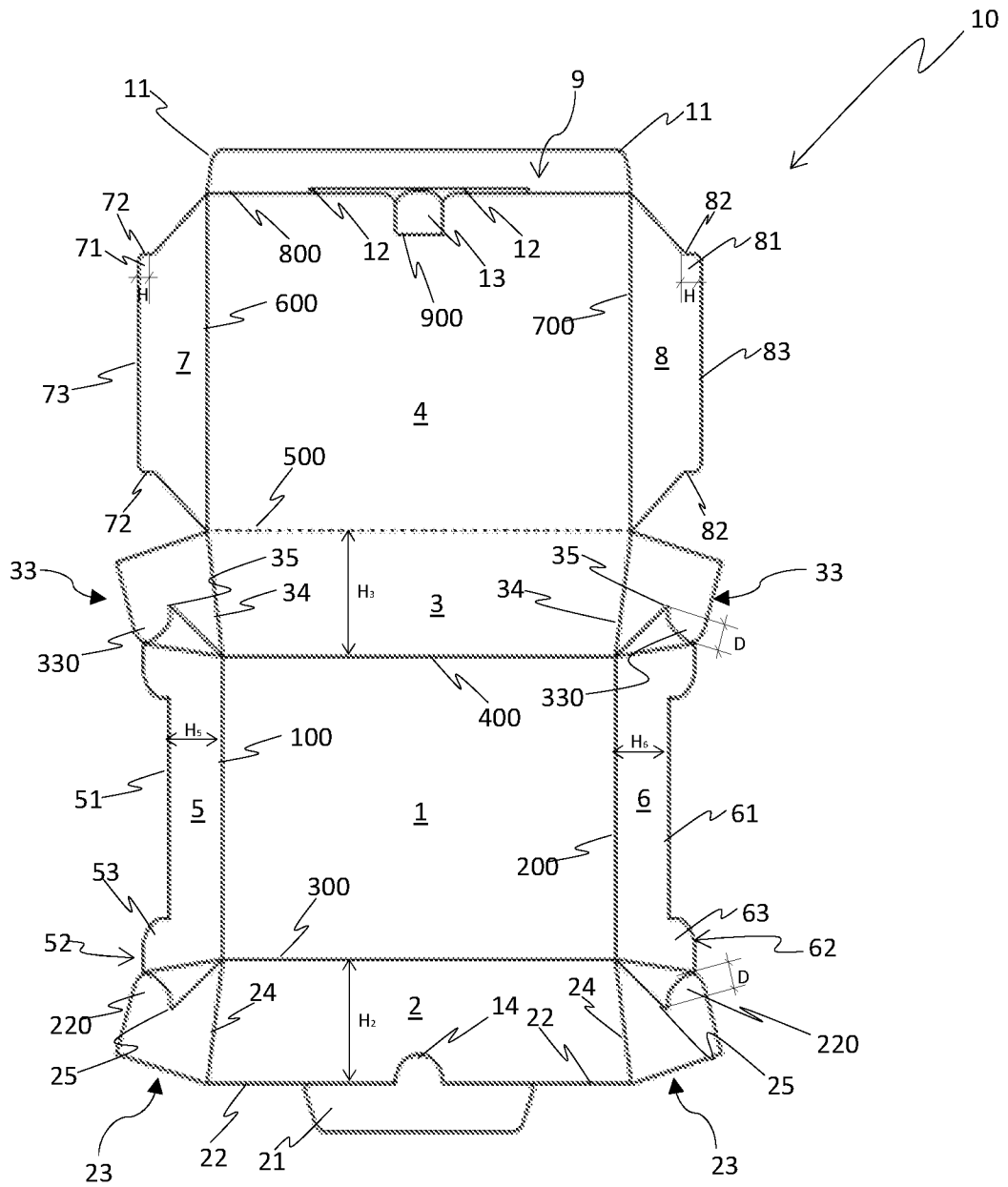

Fig.1

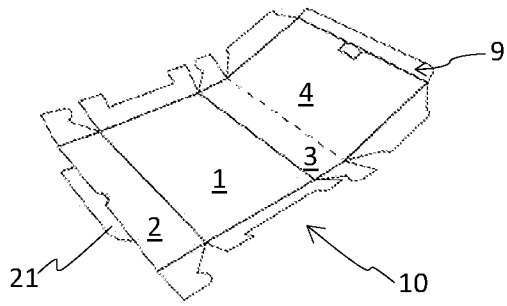

Fig. 2a

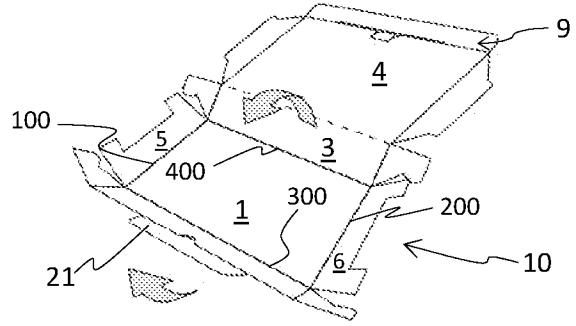

Fig. 2b

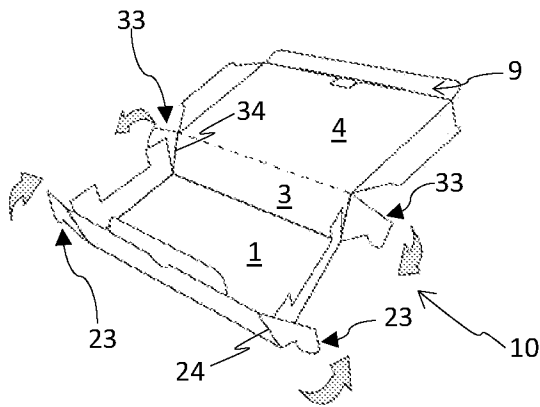

Fig. 2c

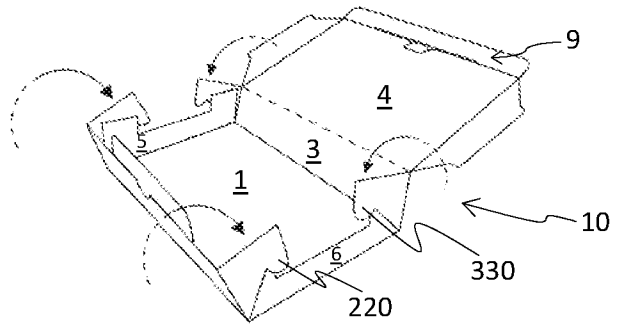

Fig. 2d

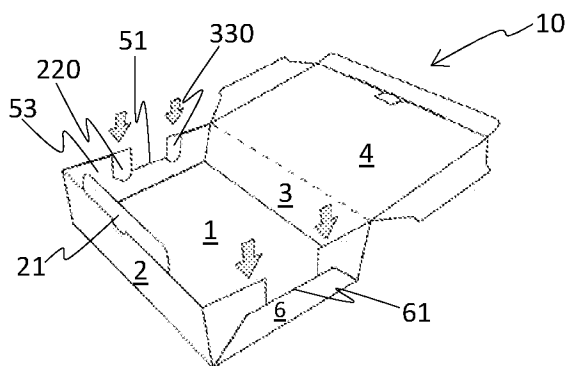

Fig. 2e

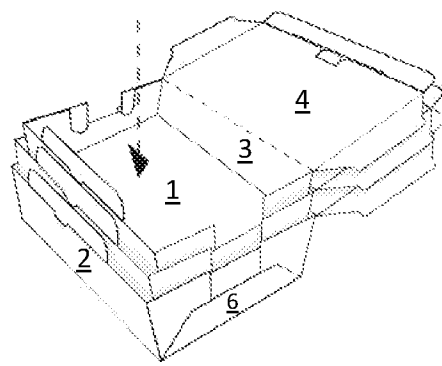

Fig. 3

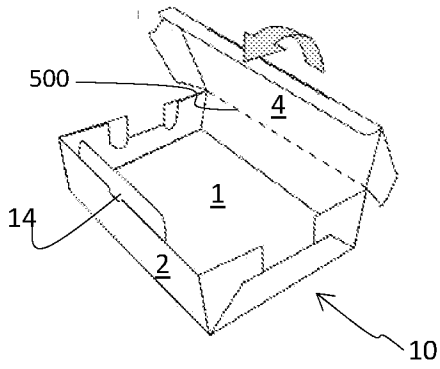

Fig.4a

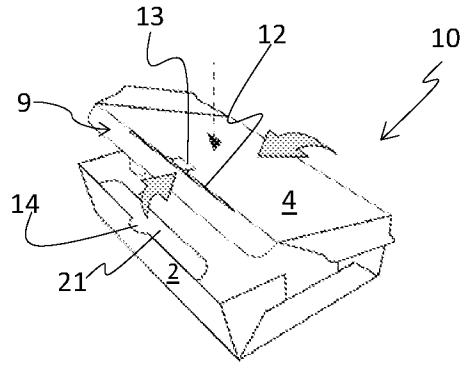

Fig.4b

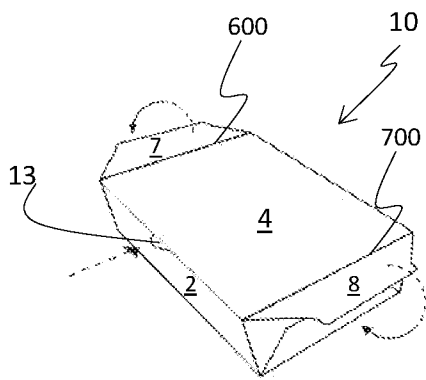

Fig.4c

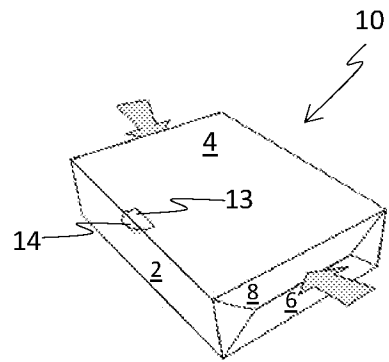

Fig.4d

INTERNATIONAL SEARCH REPORT

International application No
PCT/IB2021/057431

A. CLASSIFICATION OF SUBJECT MATTER
INV. B65D5/20 B65D5/54 B65D5/66 B65D21/02
ADD.
According to International Patent Classification (IPC) or to both national classification and IPC

B. FIELDS SEARCHED
Minimum documentation searched (classification system followed by classification symbols)
B65D
Documentation searched other than minimum documentation to the extent that such documents are included in the fields searched

Electronic data base consulted during the international search (name of data base and, where practicable, search terms used)
EPO-Internal, WPI Data

C. DOCUMENTS CONSIDERED TO BE RELEVANT

Category*	Citation of document, with indication, where appropriate, of the relevant passages	Relevant to claim No.
A	FR 1 458 683 A (BAUDET PERE ET FILS) 4 March 1966 (1966-03-04) page 1, column 2, paragraph 4; figures 1-4 -----	1-9
A	US 2017/197750 A1 (WOLF KURT [US] ET AL) 13 July 2017 (2017-07-13) paragraphs [0055] - [0066], [0088] - [0091], [0114] - [0115]; figures 7-11,18,20-21 -----	1-9
A	KR 2010 0002803 U (.) 10 March 2010 (2010-03-10) figures 1-9 -----	1-9
A	US 5 000 374 A (DEIGER ANTHONY J [US]) 19 March 1991 (1991-03-19) column 6, line 28 - column 7, line 58; figures 4-6 -----	1-9

Further documents are listed in the continuation of Box C.

See patent family annex.

* Special categories of cited documents :

- "A" document defining the general state of the art which is not considered to be of particular relevance
- "E" earlier application or patent but published on or after the international filing date
- "L" document which may throw doubts on priority claim(s) or which is cited to establish the publication date of another citation or other special reason (as specified)
- "O" document referring to an oral disclosure, use, exhibition or other means
- "P" document published prior to the international filing date but later than the priority date claimed

- "T" later document published after the international filing date or priority date and not in conflict with the application but cited to understand the principle or theory underlying the invention
- "X" document of particular relevance; the claimed invention cannot be considered novel or cannot be considered to involve an inventive step when the document is taken alone
- "Y" document of particular relevance; the claimed invention cannot be considered to involve an inventive step when the document is combined with one or more other such documents, such combination being obvious to a person skilled in the art
- "&" document member of the same patent family

Date of the actual completion of the international search 26 November 2021	Date of mailing of the international search report 06/12/2021
--	---

Name and mailing address of the ISA/ European Patent Office, P.B. 5818 Patentlaan 2 NL - 2280 HV Rijswijk Tel. (+31-70) 340-2040, Fax: (+31-70) 340-3016	Authorized officer Leijten, René
--	--

INTERNATIONAL SEARCH REPORT

Information on patent family members

International application No PCT/IB2021/057431

Patent document cited in search report	Publication date	Patent family member(s)	Publication date
FR 1458683	A	04-03-1966	NONE
US 2017197750	A1	13-07-2017	CA 3010441 A1 13-07-2017
			CN 108883853 A 23-11-2018
			EP 3400175 A1 14-11-2018
			JP 2019505444 A 28-02-2019
			TW 201730054 A 01-09-2017
			US 2017197750 A1 13-07-2017
			WO 2017120282 A1 13-07-2017
KR 20100002803	U	10-03-2010	NONE
US 5000374	A	19-03-1991	NONE