



(19) **United States**

(12) **Patent Application Publication**

**Gao et al.**

(10) **Pub. No.: US 2017/0334714 A1**

(43) **Pub. Date: Nov. 23, 2017**

(54) **INTEGRATED PACKAGE CONTAINING MEMS ACOUSTIC SENSOR AND PRESSURE SENSOR**

**Publication Classification**

(51) **Int. Cl.**  
*B81B 7/02* (2006.01)  
(52) **U.S. Cl.**  
CPC ..... *B81B 7/02* (2013.01); *B81B 2207/098* (2013.01); *B81B 2201/0257* (2013.01); *B81B 2201/0264* (2013.01); *B81B 2207/012* (2013.01)

(71) Applicant: **INVENSENSE, INC.**, San Jose, CA (US)

(72) Inventors: **Jia Gao**, Winchester, MA (US); **Brian Kim**, Fremont, CA (US); **Peter George Hartwell**, Menlo Park, CA (US); **Mozafar Maghsoudnia**, San Jose, CA (US)

(57) **ABSTRACT**

Integrated microelectromechanical systems (MEMS) acoustic sensor devices are disclosed. Integrated MEMS acoustic sensor devices can comprise a MEMS acoustic sensor element and a pressure sensor within the back cavity associated with the MEMS acoustic sensor element. Integrated MEMS acoustic sensor devices can comprise a port adapted to receive acoustic waves or pressure. Methods of fabrication are also disclosed.

(21) Appl. No.: **15/160,127**

(22) Filed: **May 20, 2016**

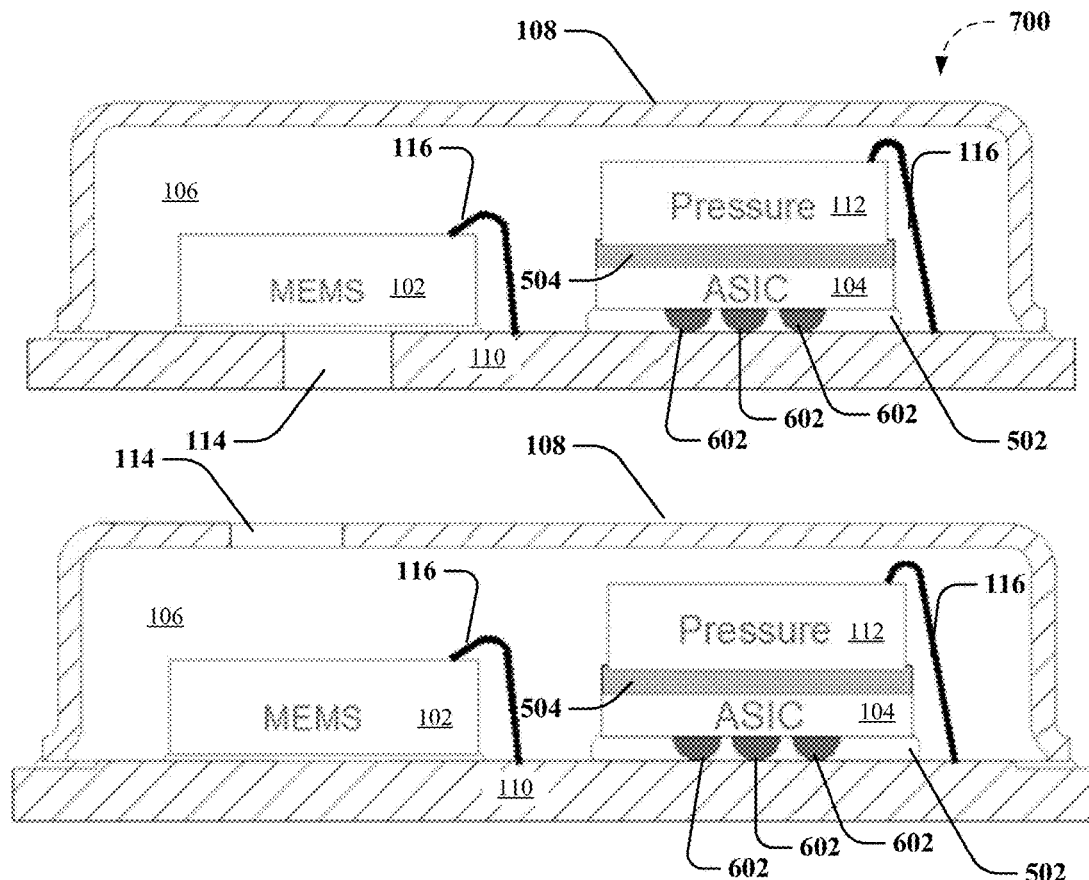

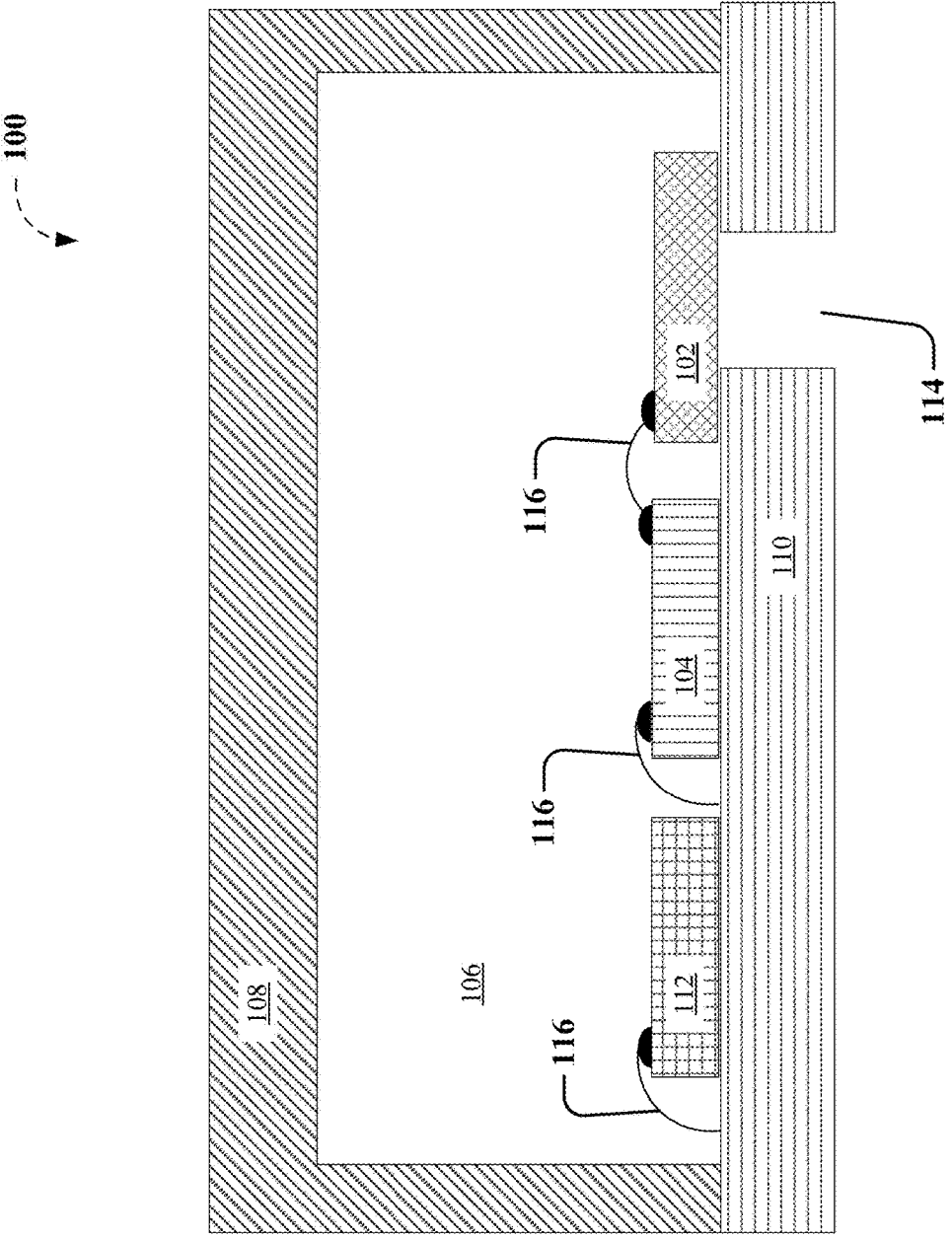

FIG. 1

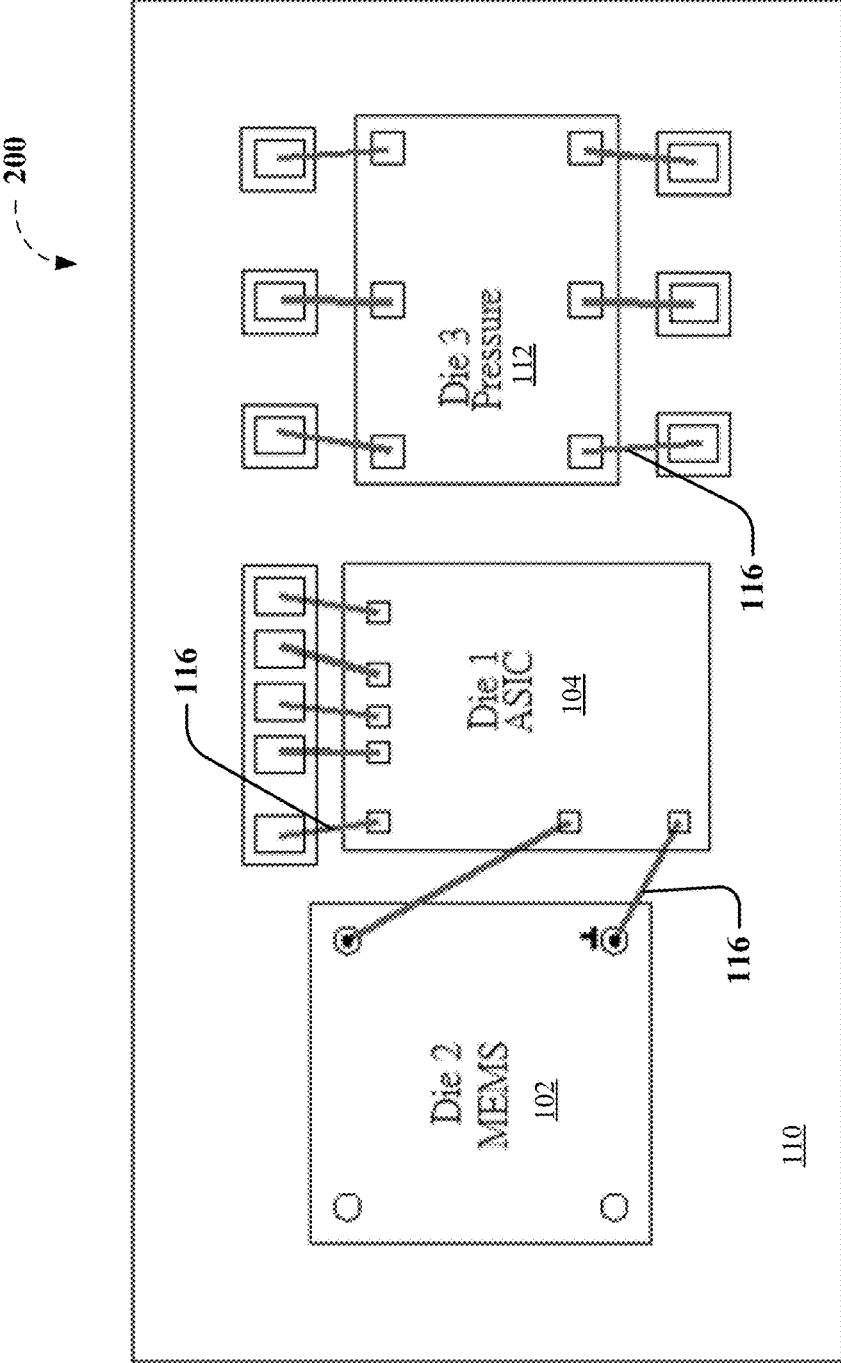

FIG. 2

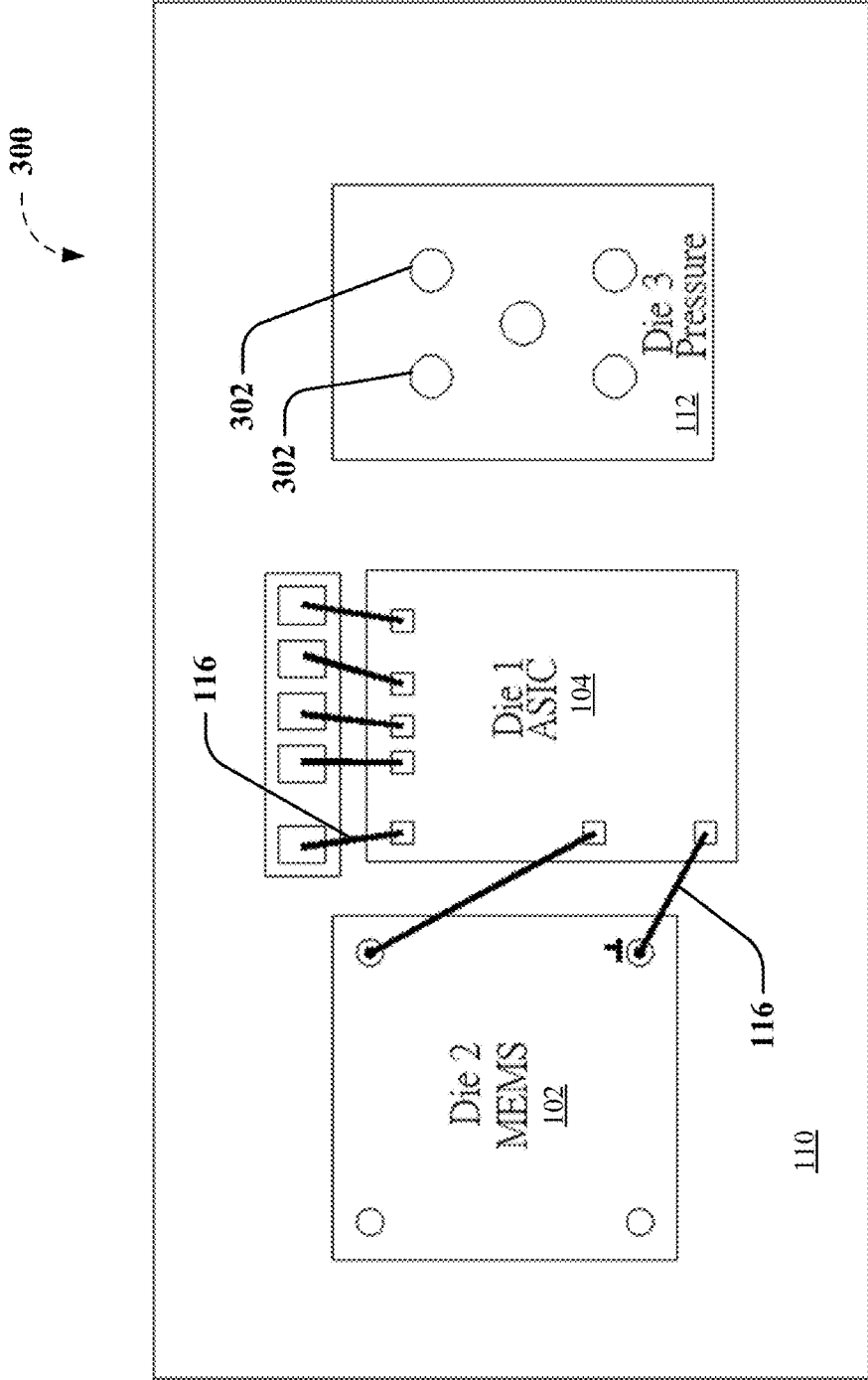

FIG. 3

400

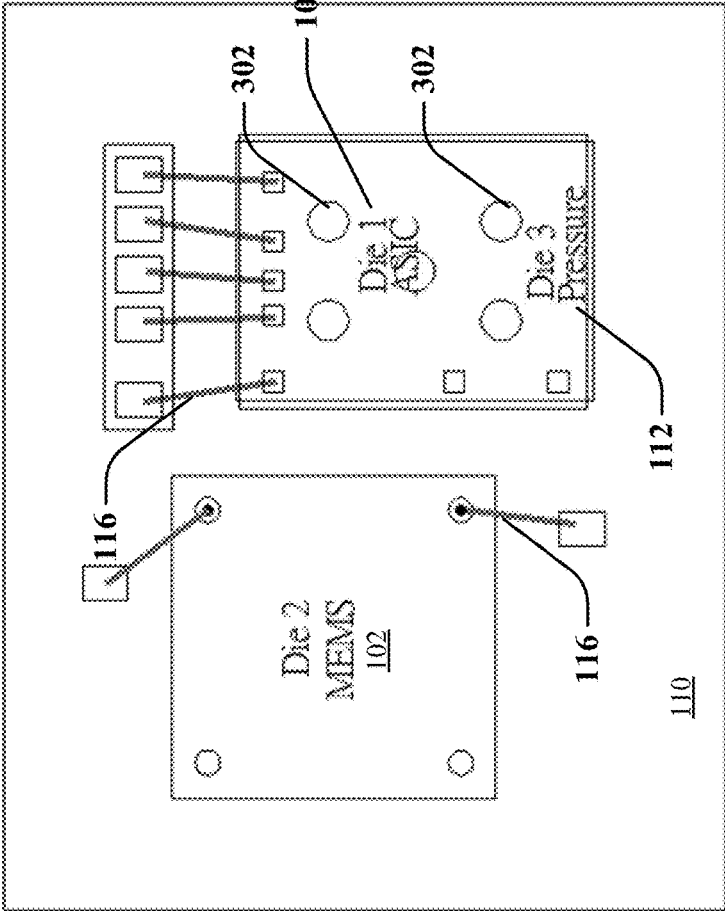

FIG. 4

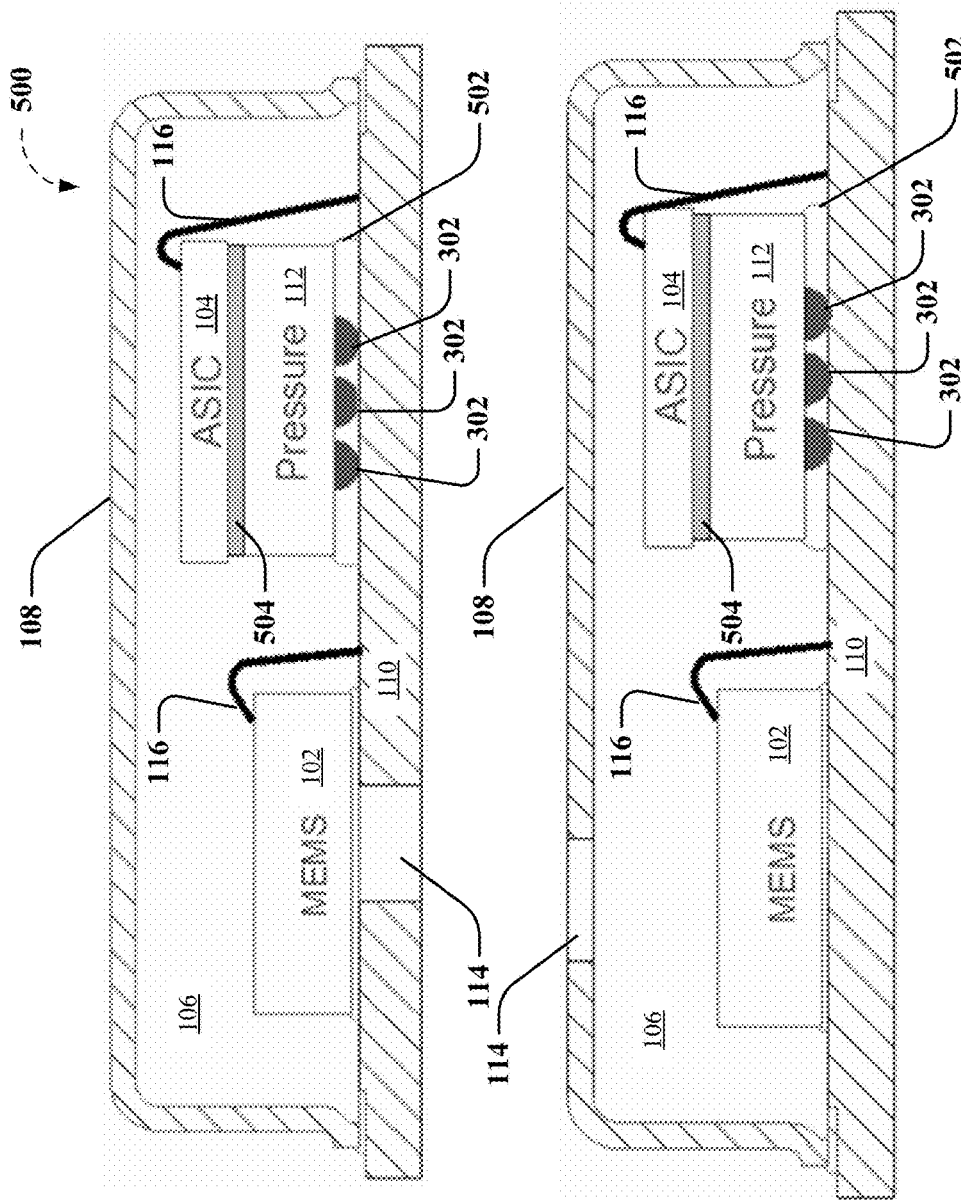

FIG. 5

600

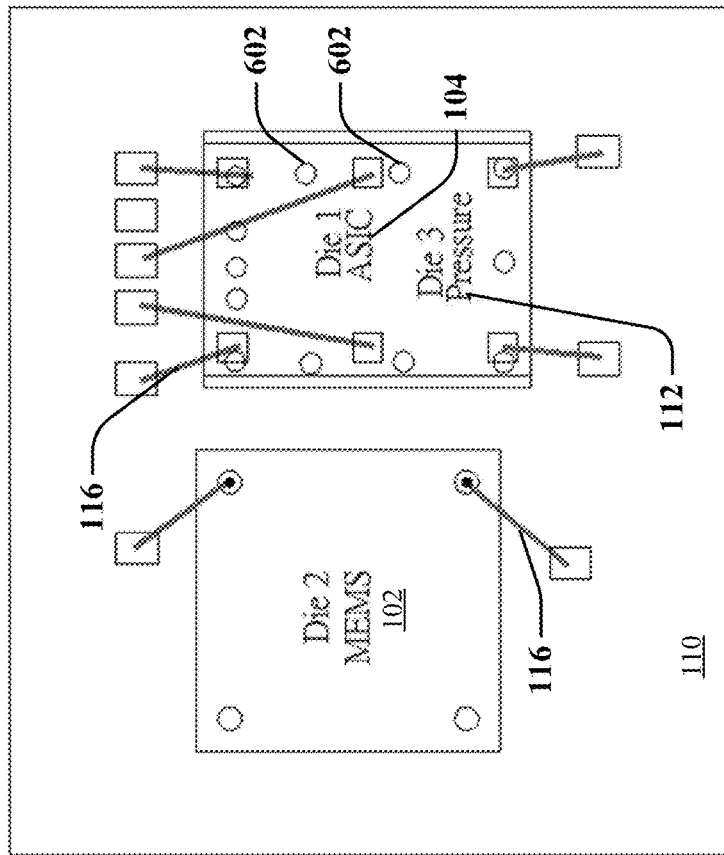

FIG. 6

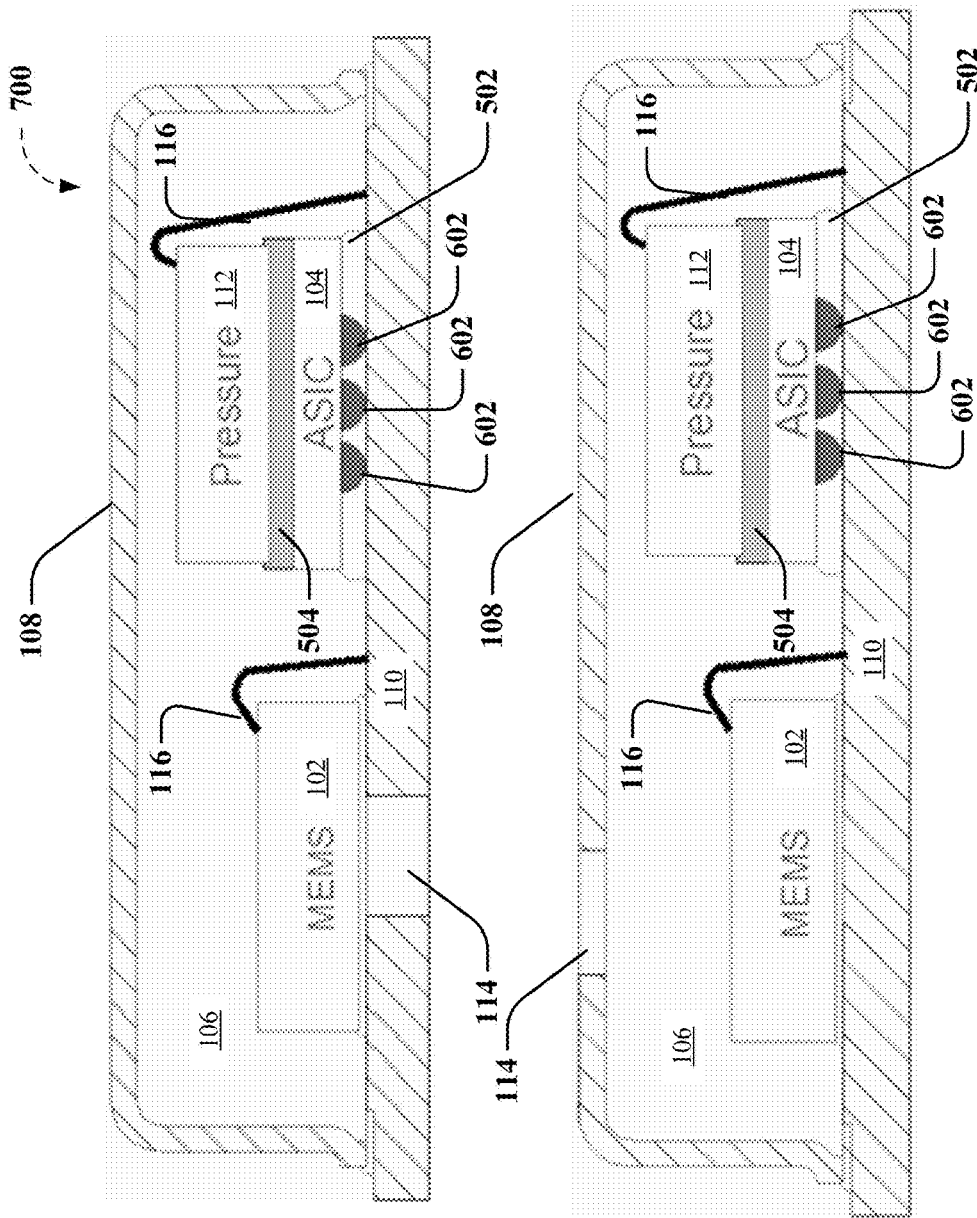
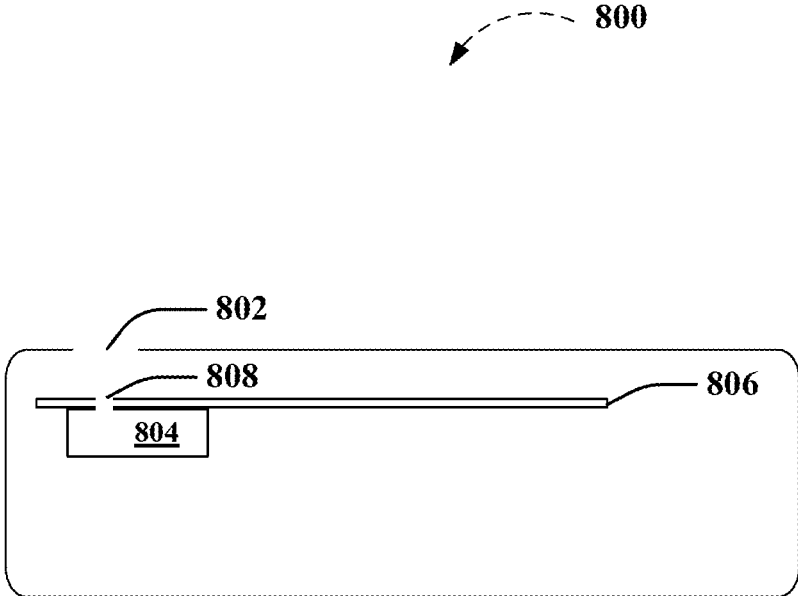

FIG. 7





**FIG. 8**

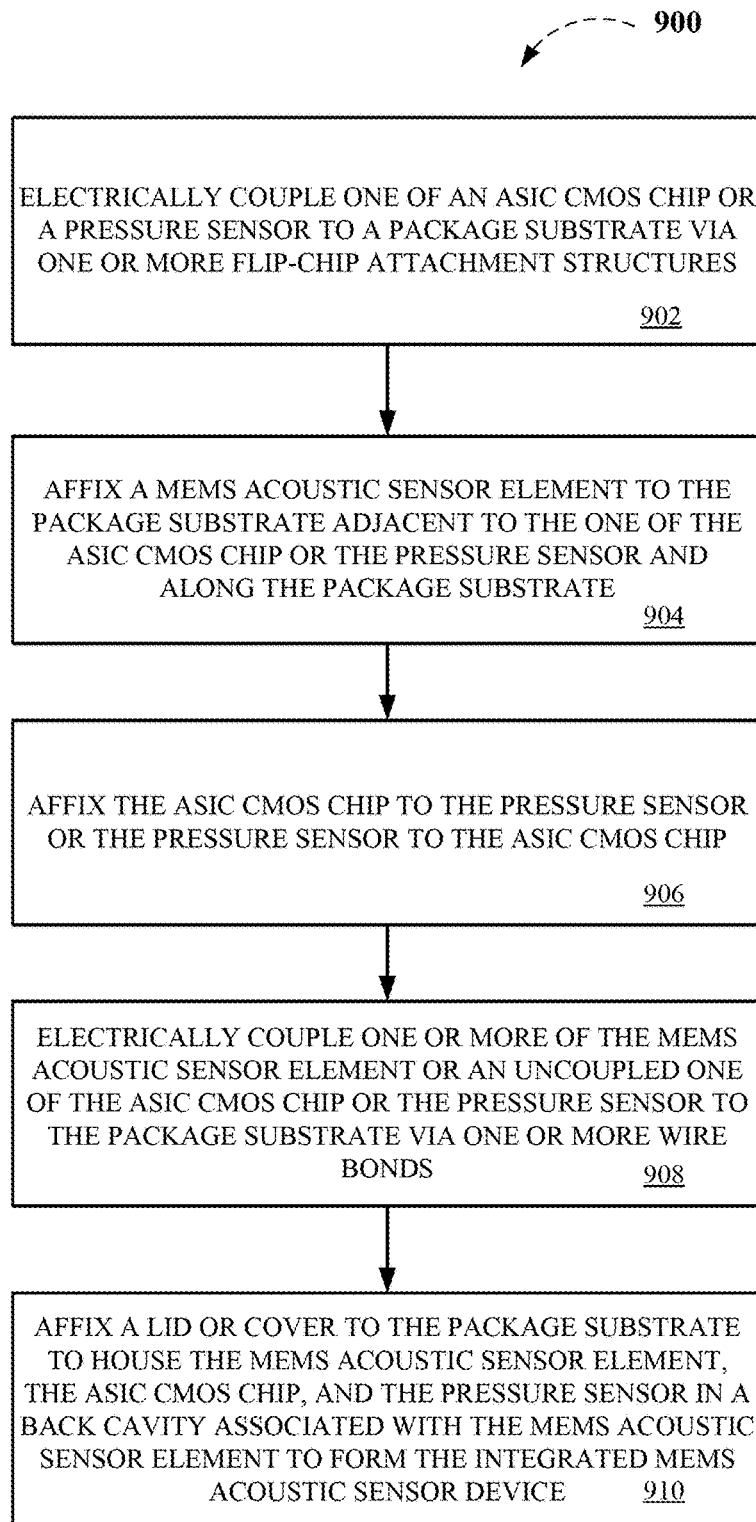

FIG. 9

## INTEGRATED PACKAGE CONTAINING MEMS ACOUSTIC SENSOR AND PRESSURE SENSOR

### TECHNICAL FIELD

[0001] Embodiments of the subject disclosure relate generally to acoustic and pressure sensors, and particularly to the integrated packaging of these sensors.

### BACKGROUND

[0002] Integration of component devices of a consumer electronics product is desirable to reduce form factor. Integration often results in size reduction because multiple devices become parts of one integrated system. In addition to integration being highly desirable for smaller device footprint, cost reductions and/or additional functionalities can be made possible through integration. However, integration of multiple devices into one system can be complex and can be made more complex in cases where each device is of a different type and/or where each device has different manufacturing and/or assembly requirements.

[0003] For example, conventionally, acoustic sensors (e.g., microphones) and pressure sensors are two separate devices. These two devices are separately tested and mounted on a customer printed circuit board (PCB) board, separately. This results in customer PCB real estate cost in addition to complexity of manufacturing, as each component must be assembled and tested separately on to the host circuit board of the product, whereas in other vertically integrated combinations, unique device configurations may be required to integrate functionality, while approaching device height limitations and while presenting limited options for rework in the event of individual sensor failure. Moreover, separately mounted and tested devices can introduce manufacturing variables into the device test and setup with reduced opportunities to improve process control and/or with added difficulty in implementing additional functionality based on the two separately mounted and tested devices with uncontrolled spacing between the two devices.

[0004] It would be desirable to have an integrated package and methodology for making an integrated package that contains both acoustic and pressure sensors and also an application specific integrated circuit (ASIC) for processing data generated by one or more of these sensors.

### SUMMARY

[0005] The following presents a simplified summary of the specification to provide a basic understanding of some aspects of the specification. This summary is not an extensive overview of the specification. It is intended to neither identify key or critical elements of the specification nor delineate any scope particular to any embodiments of the specification, or any scope of the claims. Its sole purpose is to present some concepts of the specification in a simplified form as a prelude to the more detailed description that is presented later.

[0006] In a non-limiting example, sensor devices integrated in a package are described that can comprise a microelectromechanical systems (MEMS) acoustic sensor, a pressure sensor, and an ASIC disposed in a back cavity associated with the MEMS acoustic sensor. In other non-limiting examples, integrated microphone and pressure sensing devices are provided that can comprise a stacked

arrangement of a pressure sensor and an ASIC associated with a MEMS acoustic sensor and disposed in a back cavity associated with the MEMS acoustic sensor. In further non-limiting examples, exemplary methods associated with non-limiting integrated MEMS acoustic sensor device are described.

[0007] These and other embodiments are described in more detail below.

### BRIEF DESCRIPTION OF THE DRAWINGS

[0008] FIG. 1 depicts a non-limiting schematic block diagram of an integrated microelectromechanical systems (MEMS) acoustic sensor device, in which an application specific integrated circuit (ASIC) complementary metal oxide semiconductor (CMOS) chip associated with the MEMS acoustic sensor and a pressure sensor can be located in a back cavity associated with the MEMS acoustic sensor, according to various non-limiting aspects of the subject disclosure;

[0009] FIG. 2 depicts another schematic block diagram of an integrated MEMS acoustic sensor device, in which an ASIC CMOS chip associated with MEMS acoustic sensor element and pressure sensor are located side by side with the MEMS acoustic sensor element in the back cavity;

[0010] FIG. 3 depicts a further schematic block diagram of an integrated MEMS acoustic sensor device, in which an ASIC CMOS chip associated with MEMS acoustic sensor element and pressure sensor are located side by side with the MEMS acoustic sensor element in the back cavity, according to further non-limiting aspects of the subject disclosure;

[0011] FIG. 4 depicts a non-limiting schematic block diagram of another integrated MEMS acoustic sensor device, in which a pressure sensor is flip chip attached to the package substrate with an ASIC CMOS chip stacked on the pressure sensor in the back cavity, according to further non-limiting aspects of the subject disclosure;

[0012] FIG. 5 depicts further schematic block diagrams of integrated MEMS acoustic sensor devices, in which a pressure sensor is flip chip attached to the package substrate with an ASIC CMOS chip stacked on the pressure sensor in the back cavity, according to further non-limiting aspects of the subject disclosure;

[0013] FIG. 6 depicts a non-limiting schematic block diagram of another integrated MEMS acoustic sensor device, in which an ASIC CMOS chip is flip chip attached to the package substrate with a pressure sensor stacked on the ASIC CMOS chip in the back cavity, according to further non-limiting aspects of the subject disclosure;

[0014] FIG. 7 depicts further schematic block diagrams of integrated MEMS acoustic sensor devices, in which an ASIC CMOS chip is flip chip attached to the package substrate with a pressure sensor stacked on the ASIC CMOS chip in the back cavity, according to further non-limiting aspects of the subject disclosure;

[0015] FIG. 8 depicts an example schematic block diagram for a computing environment in accordance with certain embodiments of this disclosure; and

[0016] FIG. 9 depicts an exemplary flowchart of non-limiting methods associated with an integrated MEMS acoustic sensor device, according to various non-limiting aspects of the disclosed subject matter.

## DETAILED DESCRIPTION

**[0017]** In the described embodiments, integrated circuit (IC) substrate may refer to a silicon substrate with electrical circuits, typically complementary metal oxide semiconductor (CMOS) circuits. Also, a CMOS IC substrate may include an ASIC. A cavity may refer to a recess in a substrate or a lid (cover). An enclosure may refer to a fully enclosed volume typically surrounding the microelectromechanical systems (MEMS) structure and typically formed by the IC substrate, structural layer, MEMS substrate, and the standoff seal ring. A port may be an opening through a substrate to expose the MEMS structure to the surrounding environment. It is to be appreciated that an enclosure would include an acoustic port, in various embodiments of the subject disclosure.

**[0018]** In the described embodiments, a chip includes at least one substrate typically formed from a semiconductor material. A single chip may be formed from multiple substrates, where the substrates are mechanically bonded to preserve the functionality. Multiple chips include at least two substrates, wherein the two substrates can be electrically connected, and may comprise, but do not require, mechanical bonding. A package provides electrical connection between the bond pads on the chip to a metal pad that can be soldered to a printed circuit board (PCB). A package typically comprises a substrate and a cover. It is to be appreciated that the package hermetically seals its components, with the exception that the port opening of the package allows for air flow in and out of the package. Also, it is to be appreciated that the package provides an acoustic seal, with the exception that the port opening of the package allows for sound waves or pressure to enter and exit the package.

**[0019]** In the described embodiments, a cavity may refer to an opening or recession in a substrate wafer and enclosure may refer to a fully enclosed space that includes a port opening. In the described embodiments, a back cavity may refer to a partial enclosed cavity equalized to ambient pressure. In various aspects of the subject disclosure, the back cavity provides acoustic sealing, with the exception that it allows sound waves to enter and exit by way of an acoustic MEMS acoustic sensor element (e.g., comprising a diaphragm, a backplate, etc.). In some embodiments, a back cavity can also be referred to as a back chamber. A back cavity formed within a CMOS-MEMS device can be referred to as integrated back cavity.

**[0020]** In the described embodiments, a rigid structure within an acoustic system that moves when subject to force may be referred to as a plate. A back plate may be a perforated plate used as an electrode to electrically sense the movable plate. In the described embodiments, perforations can refer to acoustic openings for reducing air damping in moving plates. An acoustic port may refer to an opening for sensing acoustic waves or pressure. Acoustic barrier may be a structure that prevents acoustic pressure from reaching certain portions of the device.

**[0021]** As described in the background, various device and package considerations can preclude the integration of existing MEMS acoustic sensor device designs and other sensors, such as, for example a pressure sensor. In various non-limiting embodiments, the disclosed subject matter provides integrated MEMS acoustic sensor devices, in which an ASIC CMOS chip associated with a MEMS acoustic sensor element and a pressure sensor can be located side by side

with the MEMS acoustic sensor element on a package substrate of the integrated package and in the back cavity associated with the MEMS acoustic sensor element. As such, exemplary embodiments can be tested by a singular test set up and can be mounted on customer's PCB with one operation. Accordingly, various embodiments as described here can reduce real estate requirements to mount such integrated MEMS acoustic sensor devices on a customer's PCB. Moreover, additional functionality may also be realized by placing a MEMS acoustic sensor element and a pressure sensor within a well-defined and factory controlled distance within each other.

**[0022]** In a non-limiting aspect, integration of the integrated MEMS acoustic sensor devices can be performed at the package level, whereas exemplary MEMS acoustic sensor elements and pressure sensors can be designed and fabricated separately, which can afford the ability to optimize performance of each of the exemplary MEMS acoustic sensor elements and pressure sensors, and which can reduce integration complexity and fabrication costs.

**[0023]** In non-limiting embodiments, an exemplary pressure sensor can be flip chip attached to a package substrate and an exemplary ASIC can be stacked on top of the exemplary pressure sensor and affixed thereto via a stress isolation compound (e.g., via epoxy, a die attach film, room temperature vulcanization silicone (RTV), etc.), as further described herein. In other non-limiting embodiments, an exemplary ASIC can be flip chip attached to a package substrate and an exemplary pressure sensor can be stacked on top of the exemplary ASIC and affixed thereto via a stress isolation compound (e.g., via epoxy, a die attach film, RTV, etc.), as further described herein, which can also reduce package stress impact on pressure sensor performance.

**[0024]** Accordingly, FIG. 1 depicts non-limiting schematic block diagram of an integrated sensor device **100** (e.g., a MEMS acoustic sensor device or microphone) associated with a back cavity, according to various non-limiting aspects of the subject disclosure. Accordingly, integrated sensor device **100** can comprise a MEMS acoustic sensor element **102**, such as a MEMS microphone element or any other acoustic sensor. In various non-limiting implementations, integrated sensor device **100** can also comprise an ASIC complementary metal oxide semiconductor (CMOS) chip **104** associated with the MEMS acoustic sensor element **102**.

**[0025]** In non-limiting implementations, integrated sensor device **100** can comprise a back cavity **106**, which can be defined by a lid or cover **108** attached to package substrate **110**, according to a non-limiting aspect. In a non-limiting embodiment of the subject disclosure, lid or cover **108** can be made of metal, polymer, or ceramic, etc. In further non-limiting implementations, integrated sensor device **100** can comprise pressure sensor **112**, as further described herein. In a non-limiting aspect, the operation of the pressure sensor **112** can employ capacitance variation, resistance variation, piezoresistance variation, etc. to sense pressure and pressure variations, without limitation. It can be understood that one or more of MEMS acoustic sensor element **102** or pressure sensor **112** can comprise one or more dies.

**[0026]** In various non-limiting aspects, one or more of MEMS acoustic sensor element **102**, ASIC CMOS chip **104**, or pressure sensor **112**, and/or lid or cover **108** can be one or more of electrically coupled or mechanically affixed to package substrate **110**, via methods as further described herein. In addition, one or more of MEMS acoustic sensor

element **102** and/or pressure sensor **112** can be mechanically, electrically, and/or communicatively coupled to the ASIC CMOS chip **104** and/or package substrate **110**.

[0027] Furthermore, lid or cover **108** and package substrate **110** together can comprise integrated sensor device or package **100**, to which a customer printed circuit board (PCB) (not shown) having an orifice or other means of passing acoustic waves or pressure to one or more of MEMS acoustic sensor element **102** and/or pressure sensor **112** can be mechanically, electrically, and/or communicatively coupled. For example, acoustic waves can be received at MEMS acoustic sensor element **102** via package substrate **110** having port **114** adapted to receive acoustic waves or pressure. An attached or coupled customer PCB (not shown) providing an orifice or other means of passing the acoustic waves or pressure facilitates receiving acoustic waves or pressure at one or more of MEMS acoustic sensor element **102** and/or pressure sensor **112**.

[0028] As depicted in integrated sensor device or package **100** of FIG. 1, port **114** is shown aligned with MEMS acoustic sensor element **102**, but as further described herein, port **114** need not be aligned with MEMS acoustic sensor element **102** or located in package substrate **110**. In addition, port **114** in package substrate **110** can receive acoustic waves or pressure for sensing by MEMS acoustic sensor element **102**, and, depending on the embodiment can receive other environmental phenomena such as ambient pressure. MEMS acoustic sensor element **102** is shown positioned adjacent to the ASIC CMOS chip **104** on the package substrate **110**, in accordance with exemplary non-limiting embodiments of the subject.

[0029] As described above, one or more of MEMS acoustic sensor element **102** and/or pressure sensor **112** can be electrically and/or communicatively coupled to the ASIC CMOS chip **104** and/or package substrate **110**. Thus, FIG. 1 depicts wire bonds **116** electrically coupling pressure sensor **112** and ASIC CMOS chip **104** to the package substrate **110** and MEMS acoustic sensor element **102** to ASIC CMOS chip **104**. In other non-limiting implementations, pressure sensor **112** can be electrically and/or communicatively coupled to the ASIC CMOS chip **104** such that the ASIC CMOS chip **104** can facilitate processing changes in two sensor elements, for example, sensor elements associated with MEMS acoustic sensor element **102** and pressure sensor **112**. Thus, in a non-limiting aspect, sensor element of the MEMS acoustic sensor element **102** and the sensor element of the pressure sensor **112** may share the electronic processing capabilities of the ASIC CMOS chip **104** and/or sensor element of the pressure sensor **112** may employ a separate ASIC (not shown) for electronic processing.

[0030] It is understood that dimensional terms, such as “top”, “bottom”, “side”, and the like, as used herein, are relative and their use in describing various embodiments is merely for the sake of discussion and providing examples. It is understood that other dimensional relations may be employed and/or the same dimensional relation may be an opposite relation as that which is disclosed herein. For example, one or more of pressure sensor **112** and/or ASIC CMOS chip **104** can be flipped such that one or more of pressure sensor **112** and/or ASIC CMOS chip **104** can be electrically coupled to package substrate **110** via a flip-chip attachment structure, whereas one of pressure sensor **112** or ASIC CMOS chip **104** can be stacked upon the other adjacent to and along package substrate **110** from MEMS

acoustic sensor element **102**, as further described herein. While one MEMS acoustic sensor element **102** and one pressure sensor **112** is shown and discussed herein, it is understood that more than one of each such sensors may be employed. The foregoing alternatives apply to the remaining embodiments of the subject disclosure as shown and discussed herein in addition to others not necessarily shown or discussed herein but contemplated.

[0031] FIG. 2 depicts another schematic block diagram of an integrated MEMS acoustic sensor device **200**, in which an ASIC CMOS chip **104** associated with MEMS acoustic sensor element **102** and pressure sensor **112** are located side by side with the MEMS acoustic sensor element **102** in the back cavity **106** (not shown). As with integrated sensor device **100** of FIG. 1 described above, integrated sensor device **200** can comprise a MEMS acoustic sensor element **102**, such as a MEMS microphone element or any other acoustic sensor, ASIC CMOS chip **104** associated with the MEMS acoustic sensor element **102**, and pressure sensor **112** located side by side along package substrate **110**. In the integrated sensor device **200** of FIG. 2, one or more of MEMS acoustic sensor element **102**, ASIC CMOS chip **104**, or pressure sensor **112**, can be one or more of electrically coupled or mechanically affixed to package substrate **110**. As further described above, one or more of MEMS acoustic sensor element **102** and/or pressure sensor **112** can be electrically and/or communicatively coupled to the ASIC CMOS chip **104** and/or package substrate **110**. Thus, FIG. 2 depicts wire bonds **116** electrically coupling pressure sensor **112** and ASIC CMOS chip **104** to the package substrate **110** and MEMS acoustic sensor element **102** to ASIC CMOS chip **104**. It can be understood that, in other non-limiting implementations, pressure sensor **112** can be electrically and/or communicatively coupled to the ASIC CMOS chip **104** such that the ASIC CMOS chip **104** can facilitate processing changes in two sensor elements, for example, sensor elements associated with MEMS acoustic sensor element **102** and pressure sensor **112**. As a result, in a non-limiting aspect, sensor element of the MEMS acoustic sensor element **102** and the sensor element of the pressure sensor **112** may share the electronic processing capabilities of the ASIC CMOS chip **104** and/or sensor element of the pressure sensor **112** may employ a separate ASIC (not shown) for electronic processing. Moreover, it can be understood that integrated sensor device **200** can comprise a back cavity **106** (not shown), which can be defined by a lid or cover **108** (not shown) attached to package substrate **110** and which lid or cover **108** (not shown) can house or encompass MEMS acoustic sensor element **102**, ASIC CMOS chip **104**, and pressure sensor **112**, according to a non-limiting aspect, as depicted in FIG. 1.

[0032] FIG. 3 depicts a further schematic block diagram of an integrated MEMS acoustic sensor device **300**, in which an ASIC CMOS chip **104** associated with MEMS acoustic sensor element **102** and pressure sensor **112** are located side by side with the MEMS acoustic sensor element **102** in the back cavity **106** (not shown), according to further non-limiting aspects of the subject disclosure. As with integrated sensor device **100/200** of FIGS. 1-2 described above, integrated sensor device **300** can comprise a MEMS acoustic sensor element **102**, such as a MEMS microphone element or any other acoustic sensor, ASIC CMOS chip **104** associated with the MEMS acoustic sensor element **102**, and pressure sensor **112** located adjacent to MEMS acoustic

sensor element 102 and along package substrate 110. In the integrated sensor device 300 of FIG. 3, one or more of MEMS acoustic sensor element 102, ASIC CMOS chip 104, or pressure sensor 112, can be one or more of electrically coupled or mechanically affixed to package substrate 110.

[0033] As further described above, one or more of MEMS acoustic sensor element 102 and/or pressure sensor 112 can be electrically and/or communicatively coupled to the ASIC CMOS chip 104 and/or package substrate 110. Thus, FIG. 3 depicts wire bonds 116 electrically coupling ASIC CMOS chip 104 to the package substrate 110 and MEMS acoustic sensor element 102 to ASIC CMOS chip 104. It can be understood that, while for other non-limiting implementations, pressure sensor 112 can be electrically and/or communicatively coupled to the ASIC CMOS chip 104 such that the ASIC CMOS chip 104 can facilitate sensor element of the MEMS acoustic sensor element 102 and the sensor element of the pressure sensor 112 sharing electronic processing capabilities of the ASIC CMOS chip 104, other non-limiting implementations can comprise pressure sensor 112 electrically and/or communicatively coupled to package substrate 110. Thus, in another non-limiting aspect, sensor element of the pressure sensor 112 may employ a separate ASIC (not shown) for electronic processing. As a non-limiting example as depicted in FIG. 3, integrated sensor device 300 can further comprise one or more flip-chip attachment structures 302 (e.g., comprising one or more solder balls, solder bumps, copper pillars, gold bumps, etc.) that can facilitate electrically and/or communicatively coupling pressure sensor 112 to package substrate 110. Moreover, it can be understood that integrated sensor device 300 can comprise a back cavity 106 (not shown), which can be defined by a lid or cover 108 (not shown) attached to package substrate 110 and which lid or cover 108 (not shown) can house or encompass MEMS acoustic sensor element 102, ASIC CMOS chip 104, and pressure sensor 112, according to a non-limiting aspect, as depicted in FIG. 1.

[0034] FIG. 4 depicts a non-limiting schematic block diagram of another integrated MEMS acoustic sensor device 400, in which a pressure sensor 112 is flip chip attached to the package substrate 110 with an ASIC CMOS chip 104 stacked on the pressure sensor 112 in the back cavity 106 (not shown), according to further non-limiting aspects of the subject disclosure. As with integrated sensor device 100/200/300 of FIGS. 1-3 described above, integrated sensor device 400 can comprise a MEMS acoustic sensor element 102, such as a MEMS microphone element or any other acoustic sensor, ASIC CMOS chip 104 associated with the MEMS acoustic sensor element 102, and pressure sensor 112 located adjacent to MEMS acoustic sensor element 102 and along package substrate 110. In the integrated sensor device 400 of FIG. 4, one or more of MEMS acoustic sensor element 102, ASIC CMOS chip 104, or pressure sensor 112, can be one or more of electrically coupled or mechanically affixed to package substrate 110. As a non-limiting example as depicted in FIG. 4, integrated sensor device 400 can further comprise one or more flip-chip attachment structures 302 (e.g., comprising one or more solder balls, solder bumps, copper pillars, gold bumps, etc.) that can facilitate electrically and/or communicatively coupling pressure sensor 112 to package substrate 110. As further described herein, ASIC CMOS chip 104 can be located on top of pressure sensor 112, wherein pressure sensor 112 is affixed

to the package substrate 110, or between pressure sensor 112 and the package substrate 110. Thus, as depicted in FIG. 4, integrated sensor device 400 can further comprise ASIC CMOS chip 104 stacked on top of pressure sensor 112 and affixed to pressure sensor 112 via a stress isolation compound (not shown) (e.g., via epoxy, a die attach film, RTV, etc.), in a further non-limiting aspect.

[0035] As further described above, one or more of MEMS acoustic sensor element 102 and/or pressure sensor 112 can be electrically and/or communicatively coupled to the ASIC CMOS chip 104 and/or package substrate 110. Thus, FIG. 4 depicts wire bonds 116 electrically coupling ASIC CMOS chip 104 and MEMS acoustic sensor element 102 to the package substrate 110. It can be understood that, while for other non-limiting implementations, pressure sensor 112 can be electrically and/or communicatively coupled to the ASIC CMOS chip 104 such that the ASIC CMOS chip 104 can facilitate sensor element of the MEMS acoustic sensor element 102 and the sensor element of the pressure sensor 112 sharing electronic processing capabilities of the ASIC CMOS chip 104, other non-limiting implementations can comprise pressure sensor 112 electrically and/or communicatively coupled to package substrate 110. Thus, in another non-limiting aspect, sensor element of the pressure sensor 112 may employ a separate ASIC (not shown) for electronic processing. Moreover, it can be understood that integrated sensor device 400 can comprise a back cavity 106 (not shown), which can be defined by a lid or cover 108 (not shown) attached to package substrate 110 and which lid or cover 108 (not shown) can house or encompass MEMS acoustic sensor element 102, ASIC CMOS chip 104, and pressure sensor 112, according to a non-limiting aspect, as depicted in FIG. 1, or as further described regarding FIG. 5.

[0036] FIG. 5 depicts further schematic block diagrams of integrated MEMS acoustic sensor devices 500, in which a pressure sensor 112 is flip chip attached to the package substrate 110 with an ASIC CMOS chip 104 stacked on the pressure sensor 112 in the back cavity 106, according to further non-limiting aspects of the subject disclosure. As with integrated sensor device 100/200/300/400 of FIGS. 1-4 described above, integrated sensor devices 500 can comprise a MEMS acoustic sensor element 102, such as a MEMS microphone element or any other acoustic sensor, ASIC CMOS chip 104 associated with the MEMS acoustic sensor element 102, and pressure sensor 112 located adjacent to MEMS acoustic sensor element 102 and along package substrate 110. In the integrated sensor devices 500 of FIG. 5, one or more of MEMS acoustic sensor element 102, ASIC CMOS chip 104, or pressure sensor 112, can be one or more of electrically coupled or mechanically affixed to package substrate 110. As a non-limiting example as depicted in FIG. 5, integrated sensor devices 500 can further comprise one or more flip-chip attachment structures 302 (e.g., comprising one or more solder balls, solder bumps, copper pillars, gold bumps, etc.) that can facilitate electrically and/or communicatively coupling pressure sensor 112 to package substrate 110. In a non-limiting aspect, various embodiments of integrated sensor devices 500 can comprise an underfill material 502 (e.g., RTV, other soft material, etc.) between pressure sensor 112 and package substrate 110 for stress isolation of pressure sensor 112 from package substrate 110.

[0037] As further described herein, ASIC CMOS chip 104 can be located on top of pressure sensor 112, wherein pressure sensor 112 is affixed to the package substrate 110,

or between pressure sensor 112 and the package substrate 110. Thus, as depicted in FIG. 5, integrated sensor devices 500 can further comprise ASIC CMOS chip 104 stacked on top of pressure sensor 112 and affixed to pressure sensor 112 via a stress isolation compound 504 (e.g., via epoxy, a die attach film, RTV, etc.), in a further non-limiting aspect. As further described above, one or more of MEMS acoustic sensor element 102 and/or pressure sensor 112 can be electrically and/or communicatively coupled to the ASIC CMOS chip 104 and/or package substrate 110. Thus, FIG. 5 depicts wire bonds 116 electrically coupling ASIC CMOS chip 104 and MEMS acoustic sensor element 102 to the package substrate 110. It can be understood that, while for other non-limiting implementations, pressure sensor 112 can be electrically and/or communicatively coupled to the ASIC CMOS chip 104 such that the ASIC CMOS chip 104 can facilitate sensor element of the MEMS acoustic sensor element 102 and the sensor element of the pressure sensor 112 sharing electronic processing capabilities of the ASIC CMOS chip 104, other non-limiting implementations can comprise pressure sensor 112 electrically and/or communicatively coupled to package substrate 110. Thus, in another non-limiting aspect, sensor element of the pressure sensor 112 may employ a separate ASIC (not shown) for electronic processing. Moreover, it can be understood that integrated sensor devices 500 can comprise a back cavity 106, which can be defined by a lid or cover 108 attached to package substrate 110 and which lid or cover 108 can house or encompass MEMS acoustic sensor element 102, ASIC CMOS chip 104, and pressure sensor 112, according to a non-limiting aspect. In addition, it is noted that port 114 adapted to receive acoustic waves or pressure can be located in package substrate 110 or lid or cover 108 as further depicted regarding integrated sensor devices 500 of FIG. 5.

[0038] FIG. 6 depicts a non-limiting schematic block diagram of another integrated MEMS acoustic sensor device 600, in which an ASIC CMOS chip 104 is flip chip attached to the package substrate 110 with a pressure sensor 112 stacked on the ASIC CMOS chip 104 in the back cavity 106 (not shown), according to further non-limiting aspects of the subject disclosure. As with integrated sensor device 100/200/300/400/500 of FIGS. 1-5 described above, integrated sensor device 600 can comprise a MEMS acoustic sensor element 102, such as a MEMS microphone element or any other acoustic sensor, pressure sensor 112, and ASIC CMOS chip 104, associated with the MEMS acoustic sensor element 102, and located adjacent to MEMS acoustic sensor element 102 and along package substrate 110. In the integrated sensor device 600 of FIG. 6, one or more of MEMS acoustic sensor element 102, ASIC CMOS chip 104, or pressure sensor 112, can be one or more of electrically coupled or mechanically affixed to package substrate 110. As a non-limiting example as depicted in FIG. 6, integrated sensor device 600 can further comprise one or more flip-chip attachment structures 602 (e.g., comprising one or more solder balls, solder bumps, copper pillars, gold bumps, etc.) that can facilitate electrically and/or communicatively coupling ASIC CMOS chip 104 to package substrate 110. As further described herein, pressure sensor 112 can be located on top of ASIC CMOS chip 104, wherein ASIC CMOS chip 104 is affixed to the package substrate 110, or between ASIC CMOS chip 104 and the package substrate 110. Thus, as depicted in FIG. 6, integrated sensor device 600 can further comprise pressure sensor 112 stacked on top of ASIC CMOS

chip 104 and affixed to ASIC CMOS chip 104 via a stress isolation compound (not shown) (e.g., via epoxy, a die attach film, RTV, etc.), in a further non-limiting aspect.

[0039] As further described above, one or more of MEMS acoustic sensor element 102 and/or pressure sensor 112 can be electrically and/or communicatively coupled to the ASIC CMOS chip 104 and/or package substrate 110. Thus, FIG. 6 depicts wire bonds 116 electrically coupling pressure sensor 112 and MEMS acoustic sensor element 102 to the package substrate 110. It can be understood that, while for other non-limiting implementations, pressure sensor 112 can be electrically and/or communicatively coupled to the ASIC CMOS chip 104 such that the ASIC CMOS chip 104 can facilitate sensor element of the MEMS acoustic sensor element 102 and the sensor element of the pressure sensor 112 sharing electronic processing capabilities of the ASIC CMOS chip 104, other non-limiting implementations can comprise pressure sensor 112 electrically and/or communicatively coupled to package substrate 110. Thus, in another non-limiting aspect, sensor element of the pressure sensor 112 may employ a separate ASIC (not shown) for electronic processing. Moreover, it can be understood that integrated sensor device 600 can comprise a back cavity 106 (not shown), which can be defined by a lid or cover 108 (not shown) attached to package substrate 110 and which lid or cover 108 (not shown) can house or encompass MEMS acoustic sensor element 102, ASIC CMOS chip 104, and pressure sensor 112, according to a non-limiting aspect, as depicted in FIG. 1, or as further described regarding FIG. 7.

[0040] FIG. 7 depicts further schematic block diagrams of integrated MEMS acoustic sensor devices 700, in which an ASIC CMOS chip 104 is flip chip attached to the package substrate 110 with a pressure sensor 112 stacked on the ASIC CMOS chip 104 in the back cavity 106, according to further non-limiting aspects of the subject disclosure. As with integrated sensor device 100/200/300/400/500/600 of FIGS. 1-6 described above, integrated sensor devices 700 can comprise a MEMS acoustic sensor element 102, such as a MEMS microphone element or any other acoustic sensor, pressure sensor 112, and ASIC CMOS chip 104, associated with the MEMS acoustic sensor element 102, and located adjacent to MEMS acoustic sensor element 102 and along package substrate 110. In the integrated sensor devices 700 of FIG. 7, one or more of MEMS acoustic sensor element 102, ASIC CMOS chip 104, or pressure sensor 112, can be one or more of electrically coupled or mechanically affixed to package substrate 110. As a non-limiting example as depicted in FIG. 7, integrated sensor devices 700 can further comprise one or more flip-chip attachment structures 602 (e.g., comprising one or more solder balls, solder bumps, copper pillars, gold bumps, etc.) that can facilitate electrically and/or communicatively coupling ASIC CMOS chip 104 to package substrate 110. In a non-limiting aspect, various embodiments of integrated sensor devices 700 can comprise an underfill material 502 (e.g., RTV, other soft material, etc.) between ASIC CMOS chip 104 and package substrate 110 for stress isolation of ASIC CMOS chip 104 from package substrate 110.

[0041] As further described herein, pressure sensor 112 can be located on top of ASIC CMOS chip 104, wherein ASIC CMOS chip 104 is affixed to the package substrate 110, or between ASIC CMOS chip 104 and the package substrate 110. Thus, as depicted in FIG. 7, integrated sensor devices 700 can further comprise pressure sensor 112

stacked on top of ASIC CMOS chip **104** and affixed to ASIC CMOS chip **104** via a stress isolation compound **504** (e.g., via epoxy, a die attach film, room temperature vulcanization silicone (RTV), etc.), in a further non-limiting aspect. As further described above, one or more of MEMS acoustic sensor element **102** and/or pressure sensor **112** can be electrically and/or communicatively coupled to the ASIC CMOS chip **104** and/or package substrate **110**. Thus, FIG. 7 depicts wire bonds **116** electrically coupling pressure sensor **112** and MEMS acoustic sensor element **102** to the package substrate **110**. It can be understood that, while for other non-limiting implementations, pressure sensor **112** can be electrically and/or communicatively coupled to the ASIC CMOS chip **104** such that the ASIC CMOS chip **104** can facilitate sensor element of the MEMS acoustic sensor element **102** and the sensor element of the pressure sensor **112** sharing electronic processing capabilities of the ASIC CMOS chip **104**, other non-limiting implementations can comprise pressure sensor **112** electrically and/or communicatively coupled to package substrate **110**. Thus, in another non-limiting aspect, sensor element of the pressure sensor **112** may employ a separate ASIC (not shown) for electronic processing. Moreover, it can be understood that integrated sensor devices **700** can comprise a back cavity **106**, which can be defined by a lid or cover **108** attached to package substrate **110** and which lid or cover **108** can house or encompass MEMS acoustic sensor element **102**, ASIC CMOS chip **104**, and pressure sensor **112**, according to a non-limiting aspect. In addition, it is noted that port **114** adapted to receive acoustic waves or pressure can be located in package substrate **110** or lid or cover **108** as further depicted regarding integrated sensor devices **700** of FIG. 7.

**[0042]** Accordingly, various embodiments of the disclosed subject matter can comprise an exemplary sensor device (e.g., an integrated MEMS acoustic sensor device comprising integrated sensor device **100/200/300/400/500** of FIGS. **1-5**). In a non-limiting aspect, exemplary sensor device (e.g., an integrated MEMS acoustic sensor device comprising integrated sensor device **100/200/300/400/500** of FIGS. **1-5**) can comprise an exemplary package comprising a lid (e.g., lid or cover **108**) and a package substrate (e.g., package substrate **110**), wherein the package has a port (e.g., port **114**) adapted to receive acoustic waves or pressure.

**[0043]** Further non-limiting embodiments of an exemplary sensor device (e.g., an integrated MEMS acoustic sensor device comprising integrated sensor device **100/200/300/400/500** of FIGS. **1-5**) can comprise an exemplary MEMS acoustic sensor (e.g., MEMS acoustic sensor element **102**) disposed in the package on the package substrate (e.g., package substrate **110**), wherein the package defines a back cavity (e.g., back cavity **106**) associated with the MEMS acoustic sensor (e.g., MEMS acoustic sensor element **102**).

**[0044]** In still other non-limiting embodiments, an exemplary sensor device (e.g., an integrated MEMS acoustic sensor device comprising integrated sensor device **100/200/300/400/500** of FIGS. **1-5**) can comprise an exemplary pressure sensor (e.g., pressure sensor **112**) disposed in the package adjacent to the MEMS acoustic sensor (e.g., MEMS acoustic sensor element **102**) and along the package substrate (e.g., package substrate **110**). In a non-limiting aspect, exemplary pressure sensor (e.g., pressure sensor **112**) can be electrically coupled to the package substrate (e.g., package substrate **110**) via one or more of wire bonds (e.g., wire bonds **116**) or one or more flip-chip attachment structures

(e.g., one or more flip-chip attachment structures **302** comprising one or more solder balls, solder bumps, copper pillars, gold bumps, etc.).

**[0045]** In further non-limiting embodiments, an exemplary sensor device (e.g., an integrated MEMS acoustic sensor device comprising integrated sensor device **100/200/300/400/500** of FIGS. **1-5**) can comprise an exemplary ASIC (e.g., ASIC CMOS chip **104**) located in the back cavity (e.g., back cavity **106**) and electrically coupled to the MEMS acoustic sensor (e.g., MEMS acoustic sensor element **102**). In a non-limiting aspect, exemplary ASIC (e.g., ASIC CMOS chip **104**) can be located on top of exemplary pressure sensor (e.g., pressure sensor **112**), wherein pressure sensor (e.g., pressure sensor **112**) can be affixed to the package substrate, exemplary ASIC (e.g., ASIC CMOS chip **104**) can be located between the pressure sensor (e.g., pressure sensor **112**) and the package substrate (e.g., package substrate **110**), etc. In another non-limiting aspect, exemplary sensor device (e.g., an integrated MEMS acoustic sensor device comprising integrated sensor device **100/200/300/400/500** of FIGS. **1-5**) can further comprise an exemplary stress isolation compound (e.g., stress isolation compound **504** such as epoxy, a die attach film, RTV, etc.) located between the pressure sensor (e.g., pressure sensor **112**) and the ASIC (e.g., ASIC CMOS chip **104**). In still another non-limiting aspect, exemplary ASIC (e.g., ASIC CMOS chip **104**) can be electrically coupled to the pressure sensor (e.g., pressure sensor **112**), for example, as further described herein. In yet another non-limiting aspect, exemplary ASIC (e.g., ASIC CMOS chip **104**) can be electrically coupled to the package substrate (e.g., package substrate **110**) via one or more of wire bonds (e.g., wire bonds **116**) or one or more flip-chip attachment structures (e.g., one or more flip-chip attachment structures **302** comprising one or more solder balls, solder bumps, copper pillars, gold bumps, etc.).

**[0046]** Various non-limiting embodiments of the disclosed subject matter can also comprise an exemplary integrated microphone and pressure sensing device (e.g., an integrated MEMS acoustic sensor device comprising integrated sensor device **400/500** of FIGS. **4-5**). In a non-limiting aspect, exemplary integrated microphone and pressure sensing device can comprise an exemplary package comprising a lid (e.g., lid or cover **108**) and a package substrate (e.g., package substrate **110**), wherein the package has a port (e.g., port **114**) adapted to receive acoustic waves or pressure. In non-limiting aspects an exemplary port (e.g., port **114**) adapted to receive acoustic waves or pressure can be located in the lid (e.g., lid or cover **108**) or the package substrate (e.g., package substrate **110**).

**[0047]** Further non-limiting embodiments of an exemplary integrated microphone and pressure sensing device (e.g., an integrated MEMS acoustic sensor device comprising integrated sensor device **400/500** of FIGS. **4-5**) can comprise an exemplary MEMS acoustic sensor (e.g., MEMS acoustic sensor element **102**) disposed in the package on the package substrate (e.g., package substrate **110**), wherein the package defines a back cavity (e.g., back cavity **106**) associated with the MEMS acoustic sensor (e.g., MEMS acoustic sensor element **102**).

**[0048]** In still other non-limiting embodiments, an exemplary integrated microphone and pressure sensing device (e.g., an integrated MEMS acoustic sensor device comprising integrated sensor device **400/500** of FIGS. **4-5**) can



comprise an exemplary pressure sensor (e.g., pressure sensor **112**) disposed in the package adjacent to the MEMS acoustic sensor (e.g., MEMS acoustic sensor element **102**) on the package substrate (e.g., package substrate **110**), wherein exemplary pressure sensor (e.g., pressure sensor **112**) can be electrically coupled to the package substrate (e.g., package substrate **110**) via one or more flip-chip attachment structures (e.g., one or more flip-chip attachment structures **302** comprising one or more solder balls, solder bumps, copper pillars, gold bumps, etc.).

[0049] In further non-limiting embodiments, an exemplary integrated microphone and pressure sensing device (e.g., an integrated MEMS acoustic sensor device comprising integrated sensor device **400/500** of FIGS. 4-5) can comprise an exemplary ASIC (e.g., ASIC CMOS chip **104**) located in the back cavity (e.g., back cavity **106**) atop the pressure sensor (e.g., pressure sensor **112**) and electrically coupled to the MEMS acoustic sensor (e.g., MEMS acoustic sensor element **102**) via one or more of wire bonds (e.g., wire bonds **116**) to the package substrate (e.g., package substrate **110**). In another non-limiting aspect, exemplary integrated microphone and pressure sensing device (e.g., an integrated MEMS acoustic sensor device comprising integrated sensor device **400/500** of FIGS. 4-5) can further comprise an exemplary stress isolation compound (e.g., stress isolation compound **504** such as epoxy, a die attach film, RTV, etc.) located between the pressure sensor (e.g., pressure sensor **112**) and the ASIC (e.g., ASIC CMOS chip **104**). In still another non-limiting aspect, exemplary ASIC (e.g., ASIC CMOS chip **104**) can be electrically coupled to the pressure sensor (e.g., pressure sensor **112**), for example, as further described herein. In yet another non-limiting aspect, exemplary ASIC (e.g., ASIC CMOS chip **104**) can be electrically coupled to the package substrate (e.g., package substrate **110**) via one or more of wire bonds (e.g., wire bonds **116**).

[0050] Various other non-limiting embodiments of the disclosed subject matter can also comprise an exemplary integrated microphone and pressure sensing device (e.g., an integrated MEMS acoustic sensor device comprising integrated sensor device **600/700** of FIGS. 6-7). In a non-limiting aspect, exemplary integrated microphone and pressure sensing device can comprise an exemplary package comprising a lid (e.g., lid or cover **108**) and a package substrate (e.g., package substrate **110**), wherein the package has a port (e.g., port **114**) adapted to receive acoustic waves or pressure. In non-limiting aspects, an exemplary port (e.g., port **114**) adapted to receive acoustic waves or pressure can be located in the lid (e.g., lid or cover **108**) or the package substrate (e.g., package substrate **110**).

[0051] Further non-limiting embodiments of an exemplary integrated microphone and pressure sensing device (e.g., an integrated MEMS acoustic sensor device comprising integrated sensor device **600/700** of FIGS. 6-7) can comprise an exemplary MEMS acoustic sensor (e.g., MEMS acoustic sensor element **102**) disposed in the package on the package substrate (e.g., package substrate **110**), wherein the package defines a back cavity (e.g., back cavity **106**) associated with the MEMS acoustic sensor (e.g., MEMS acoustic sensor element **102**).

[0052] In still other non-limiting embodiments, an exemplary integrated microphone and pressure sensing device (e.g., an integrated MEMS acoustic sensor device comprising integrated sensor device **600/700** of FIGS. 6-7) can

comprise an exemplary ASIC (e.g., ASIC CMOS chip **104**) disposed in the package adjacent to the MEMS acoustic sensor (e.g., MEMS acoustic sensor element **102**) on the package substrate (e.g., package substrate **110**), wherein exemplary ASIC (e.g., ASIC CMOS chip **104**) can be electrically coupled to the package substrate (e.g., package substrate **110**) via one or more flip-chip attachment structures (e.g., one or more flip-chip attachment structures **302** comprising one or more solder balls, solder bumps, copper pillars, gold bumps, etc.).

[0053] In further non-limiting embodiments, an exemplary integrated microphone and pressure sensing device (e.g., an integrated MEMS acoustic sensor device comprising integrated sensor device **600/700** of FIGS. 6-7) can comprise an exemplary pressure sensor (e.g., pressure sensor **112**) located in the back cavity (e.g., back cavity **106**) atop ASIC (e.g., ASIC CMOS chip **104**) and electrically coupled to the package substrate (e.g., package substrate **110**) via one or more of wire bonds (e.g., wire bonds **116**). In another non-limiting aspect, exemplary integrated microphone and pressure sensing device (e.g., an integrated MEMS acoustic sensor device comprising integrated sensor device **600/700** of FIGS. 6-7) can further comprise an exemplary stress isolation compound (e.g., stress isolation compound **504** such as epoxy, a die attach film, RTV, etc.) located between the pressure sensor (e.g., pressure sensor **112**) and the ASIC (e.g., ASIC CMOS chip **104**).

[0054] FIG. 8 illustrates a block diagram representative of an exemplary application of various embodiments of the subject disclosure. More specifically, a block diagram of a host system **800** is shown to include an acoustic port **802** and an integrated sensor device **804** (e.g., an integrated MEMS acoustic sensor device comprising integrated sensor device **100/200/300/400/500/600/700** of FIGS. 1-7) affixed to a PCB **806** having an orifice **808** or other means of passing acoustic waves or pressure to integrated sensor device **804** (e.g., an integrated MEMS acoustic sensor device comprising integrated sensor device **100/200/300/400/500/600/700** of FIGS. 1-7). The host system **800** can be any system requiring and integrated sensor device **804** (e.g., an integrated MEMS acoustic sensor device comprising integrated sensor device **100/200/300/400/500/600/700** of FIGS. 1-7), such as a smartphone, a smart watch, a wearable exercise device, etc.

[0055] In view of the subject matter described supra, methods that can be implemented in accordance with the subject disclosure will be better appreciated with reference to the flowchart of FIG. 9. While for purposes of simplicity of explanation, the methods are shown and described as a series of blocks, it is to be understood and appreciated that such illustrations or corresponding descriptions are not limited by the order of the blocks, as some blocks may occur in different orders and/or concurrently with other blocks from what is depicted and described herein. Any non-sequential, or branched, flow illustrated via a flowchart should be understood to indicate that various other branches, flow paths, and orders of the blocks, can be implemented which achieve the same or a similar result. Moreover, not all illustrated blocks may be required to implement the methods described hereinafter.

#### Exemplary Methods

[0056] FIG. 9 depicts an exemplary flowchart of non-limiting methods **900** associated with an integrated MEMS

acoustic sensor device (e.g., an integrated MEMS acoustic sensor device comprising integrated sensor device **400/500/600/700** of FIGS. **4-7**), according to various non-limiting aspects of the subject disclosure. As a non-limiting example, exemplary methods **900** can comprise, at **902**, electrically coupling one of an ASIC CMOS chip **104** or a pressure sensor **112** to a package substrate **110** via one or more flip-chip attachment structures **302/602** (e.g., comprising one or more solder balls, solder bumps, copper pillars, gold bumps, etc.). In a non-limiting aspect, exemplary methods **900** can further comprise applying an underfill material **502** (e.g., RTV, other soft material, etc.) between pressure sensor **112** and package substrate **110**, for stress isolation of pressure sensor **112** from package substrate **110**, or between ASIC CMOS chip **104** and package substrate **110**, for stress isolation of ASIC CMOS chip **104** from package substrate **110**, as further described herein.

**[0057]** In other non-limiting implementations of methods **900**, exemplary methods **900** can comprise, at **904**, affixing a MEMS acoustic sensor element **102** to the package substrate **110** adjacent to the one the ASIC CMOS chip **104** or the pressure sensor **112** and along the package substrate **110**, as further described herein, regarding FIGS. **4-7**, for example. As a non-limiting example, exemplary methods **900** can further comprise aligning an exemplary MEMS acoustic sensor element **102** with an exemplary port **114** adapted to receive acoustic waves or pressure.

**[0058]** In still further non-limiting implementations of methods **900**, exemplary methods **900** can comprise, at **906**, affixing the ASIC CMOS chip **104** to the pressure sensor **112** or affixing the pressure sensor **112** to the ASIC CMOS chip **104**, as further described herein, regarding FIGS. **4-7**, for example. In a non-limiting aspect, exemplary methods **900** can comprise affixing the ASIC CMOS chip **104** or the pressure sensor **112** via a stress isolation compound **504** (e.g., via epoxy, a die attach film, RTV, etc.).

**[0059]** Exemplary methods **900** can further comprise, at **908**, electrically coupling one or more of the MEMS acoustic sensor element **102** or an uncoupled one of the ASIC CMOS chip **104** or the pressure sensor **112** to the package substrate **110** via one or more wire bonds **116**. As a non-limiting example, for an exemplary integrated MEMS acoustic sensor device comprising a flip-chip attached pressure sensor **112**, exemplary methods **900** can comprise electrically coupling the ASIC CMOS chip **104** to the package substrate **110** via one or more wire bonds **116**. In a further non-limiting example, for an exemplary integrated MEMS acoustic sensor device comprising a flip-chip attached ASIC CMOS chip **104**, exemplary methods **900** can comprise electrically coupling the pressure sensor **112** to the package substrate **110** via one or more wire bonds **116**.

**[0060]** Exemplary methods **900** can further comprise, at **910**, affixing lid or cover **108** to the package substrate **110** to house the MEMS acoustic sensor element **102**, the ASIC CMOS chip **104**, and the pressure sensor **112** in a back cavity associated with the MEMS acoustic sensor element **102** to form the integrated MEMS acoustic sensor device.

**[0061]** Although the description has been provided with respect to particular embodiments of the disclosed subject matter, these particular embodiments are merely illustrative and not restrictive.

**[0062]** As used herein, the term “top”, “bottom”, “left”, and “right” are relative and merely examples of the structures disclosed. It is understood that the relation of the

structures may be opposite to that which is stated. For example, the term “bottom”, as used herein, may be “top” in other embodiments of the subject disclosure.

**[0063]** As used in the description herein and throughout the claims that follow, “a”, “an”, and “the” includes plural references unless the context clearly dictates otherwise. Also, as used in the description herein and throughout the claims that follow, the meaning of “in” includes “in” and “on” unless the context clearly dictates otherwise.

**[0064]** Thus, while particular embodiments have been described herein, latitudes of modification, various changes, and substitutions are intended in the foregoing disclosures, and it will be appreciated that in some instances some features of particular embodiments will be employed without a corresponding use of other features without departing from the scope and spirit as set forth. Therefore, many modifications may be made to adapt a particular situation or material to the essential scope and spirit.

1. A sensor device, comprising:

a package comprising a lid and a package substrate, wherein the package has a port adapted to receive acoustic waves;

a microelectromechanical systems (MEMS) acoustic sensor disposed in the package on the package substrate, wherein the package defines a back cavity associated with the MEMS acoustic sensor;

a pressure sensor disposed in the package adjacent to the MEMS acoustic sensor and along the package substrate;

an application specific integrated circuit (ASIC) located in the back cavity and electrically coupled to the MEMS acoustic sensor, wherein the pressure sensor and the ASIC comprise a vertical stack; and

a stress isolation compound located between the pressure sensor and the ASIC.

2. The sensor device of claim 1, wherein the ASIC is located at least one of on top of the pressure sensor, wherein the pressure sensor is affixed to the package substrate, or between the pressure sensor and the package substrate.

3. The sensor device of claim 1, wherein the stress isolation compound positions the pressure sensor in the back cavity, free of mechanical contact with the lid and the package substrate.

4. The sensor device of claim 1, wherein the stress isolation compound comprises at least one of a room temperature vulcanization silicone (RTV), an epoxy, or a die attach film.

5. The sensor device of claim 1, wherein the ASIC is electrically coupled to the pressure sensor.

6. The sensor device of claim 1, wherein the pressure sensor is electrically coupled to the package substrate via at least one of a first plurality of wire bonds or a first flip-chip attachment structure.

7. The sensor device of claim 1, further comprising:

an underfill material located between the vertical stack and the package substrate.

8. The sensor device of claim 1, wherein the ASIC is electrically coupled to the package substrate via at least one of a second plurality of wire bonds or a second flip-chip attachment structure.

9. The sensor device of claim 8, wherein the second flip-chip attachment structure comprises at least one of a plurality of solder balls, a plurality of copper pillars, or a plurality of gold bumps.

**10.** An integrated microphone and pressure sensing device, comprising:

- a package comprising a lid and a package substrate, wherein the package has a port adapted to receive acoustic waves;
- a microelectromechanical systems (MEMS) acoustic sensor disposed in the package on the package substrate, wherein the package defines a back cavity associated with the MEMS acoustic sensor;
- an application specific integrated circuit (ASIC) located in the back cavity and electrically coupled to the MEMS acoustic sensor;
- a pressure sensor disposed in the package adjacent to the MEMS acoustic sensor, wherein the pressure sensor is electrically coupled to the package substrate, and wherein the pressure sensor and the ASIC comprise a vertical stack;
- an underfill material located between the vertical stack and the package substrate; and
- a stress isolation compound located between the pressure sensor and the ASIC.

**11.** The integrated microphone and pressure sensing device of claim **10**, wherein the stress isolation compound mechanically affixes the pressure sensor to the package substrate via the ASIC.

**12.** The integrated microphone and pressure sensing device of claim **10**, wherein the stress isolation compound comprises at least one of a room temperature vulcanization silicone (RTV), an epoxy, or a die attach film.

**13.** The integrated microphone and pressure sensing device of claim **10**, wherein the ASIC is electrically coupled to the pressure sensor via a plurality of wire bonds to the package substrate.

**14.** The integrated microphone and pressure sensing device of claim **10**, wherein the ASIC is electrically coupled to the MEMS acoustic sensor via a flip-chip attachment structure comprising at least one of a plurality of solder balls, a plurality of copper pillars, or a plurality of gold bumps.

**15.** The integrated microphone and pressure sensing device of claim **10**, wherein the port is located in the lid.

**16.** The integrated microphone and pressure sensing device of claim **10**, wherein the port is located in the package substrate.

**17.** An integrated microphone and pressure sensing device, comprising:

- a package comprising a lid and a package substrate, wherein the package has a port adapted to receive acoustic waves;
- a microelectromechanical systems (MEMS) acoustic sensor disposed in the package on the package substrate, wherein the package defines a back cavity associated with the MEMS acoustic sensor;
- an application specific integrated circuit (ASIC) disposed in the package adjacent to the MEMS acoustic sensor and electrically coupled to the package substrate;
- a pressure sensor located in the back cavity and electrically coupled to the package substrate, wherein the pressure sensor and the ASIC comprise a vertical stack, and wherein the pressure sensor is free of mechanical contact with the lid;
- a stress isolation compound located between the pressure sensor and the ASIC; and
- an underfill material located between the vertical stack and the package substrate.

**18.** The integrated microphone and pressure sensing device of claim **17**, wherein the stress isolation compound mechanically affixes the pressure sensor to the package substrate via the ASIC, and wherein the stress isolation compound positions the pressure sensor in the back cavity, free of mechanical contact with the lid and the package substrate.

**19.** The integrated microphone and pressure sensing device of claim **17**, wherein the stress isolation compound comprises at least one of a room temperature vulcanization silicone (RTV), an epoxy, or a die attach film.

**20.** The integrated microphone and pressure sensing device of claim **17**, wherein the flip-chip attachment structure comprises at least one of a plurality of solder balls, a plurality of copper pillars, or a plurality of gold bumps.

**21.** The integrated microphone and pressure sensing device of claim **17**, wherein the port is located in the lid.

**22.** The integrated microphone and pressure sensing device of claim **17**, wherein the port is located in the package substrate.

\* \* \* \* \*