



(19) **United States**

(12) **Patent Application Publication**
IQBAL

(10) **Pub. No.: US 2017/0335199 A1**

(43) **Pub. Date: Nov. 23, 2017**

(54) **SYSTEMS FOR PRODUCING ANODE GRADE COKE FROM HIGH SULFUR CRUDE OILS**

Publication Classification

(51) **Int. Cl.**
C10B 55/00 (2006.01)
C10B 3/00 (2006.01)
(52) **U.S. Cl.**
CPC **C10B 55/00** (2013.01); **C10B 3/00** (2013.01)

(71) Applicant: **KELLOGG BROWN & ROOT LLC**,
Houston, TX (US)

(72) Inventor: **Rashid IQBAL**, Houston, TX (US)

(21) Appl. No.: **15/603,224**

(22) Filed: **May 23, 2017**

Related U.S. Application Data

(60) Provisional application No. 62/340,172, filed on May 23, 2016.

(57) **ABSTRACT**

Methods and systems for producing anode grade coke are disclosed, which allow anode grade coke to be produced from crude oil having a high sulfur content. A fraction of the resid is hydrotreated while another fraction of the resid is treated in a solvent deasphalting unit. A synthetic stream is provided by blending hydrotreated resid with one or more streams from the deasphalting unit. The synthetic stream is fed to an anodic coker unit.

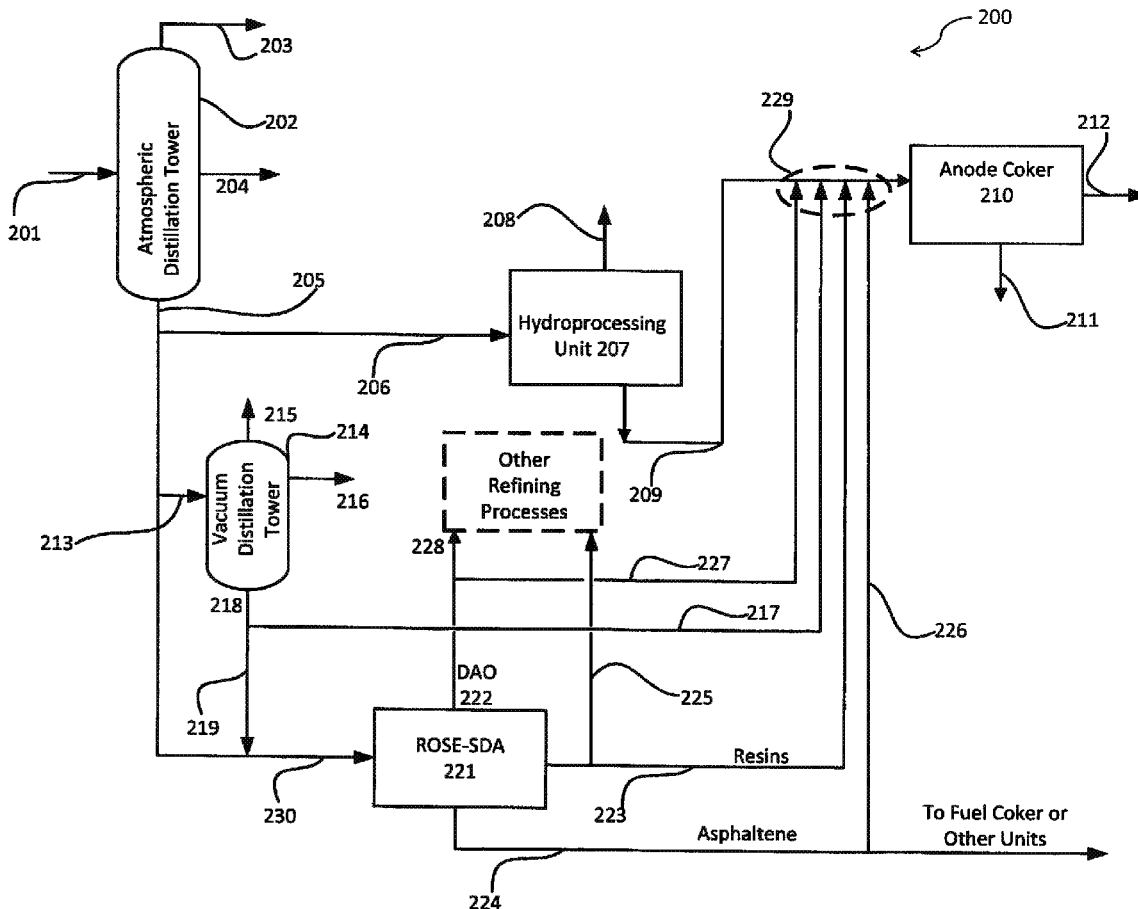

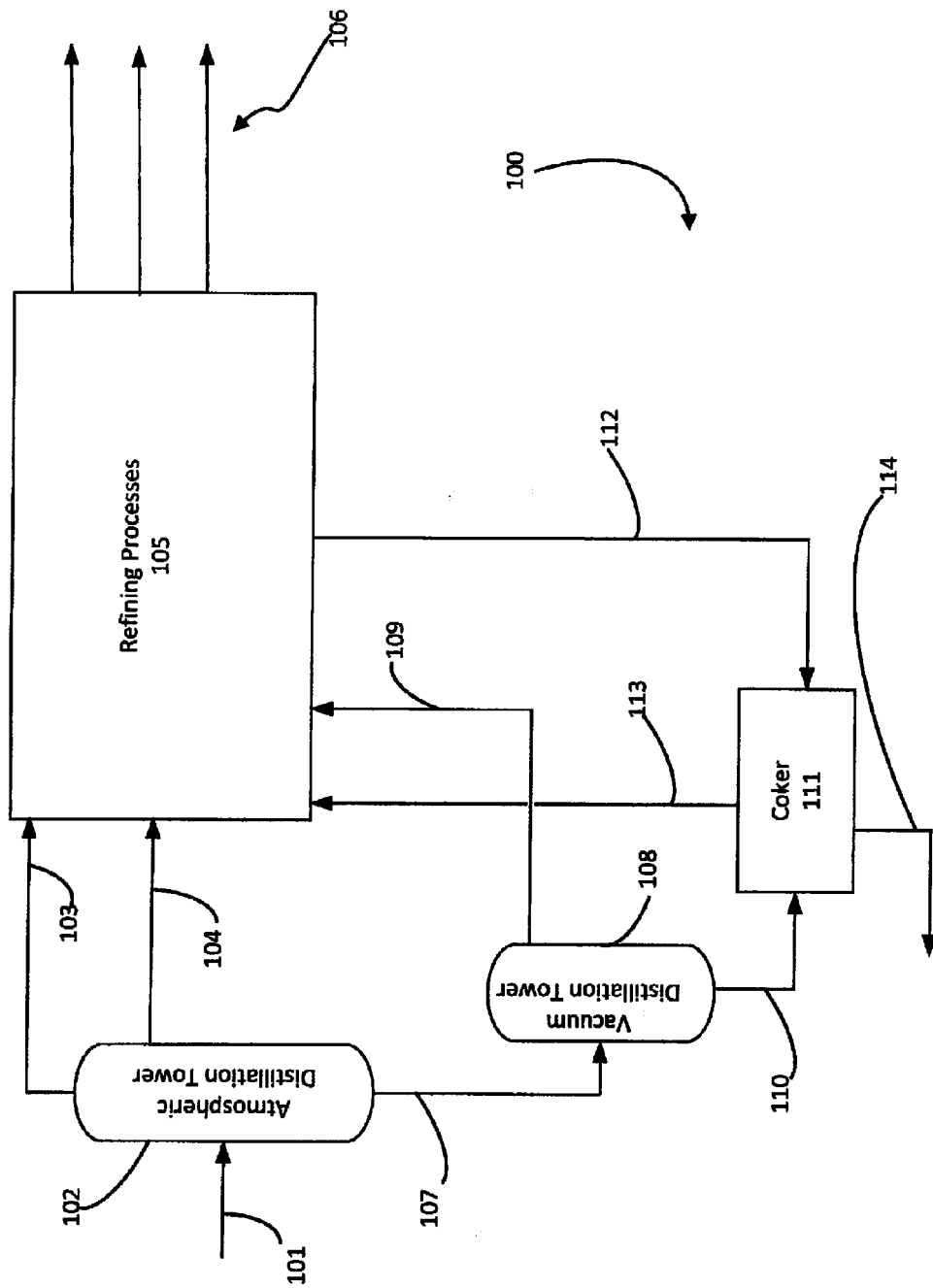

FIG. 1 (PRIOR ART)

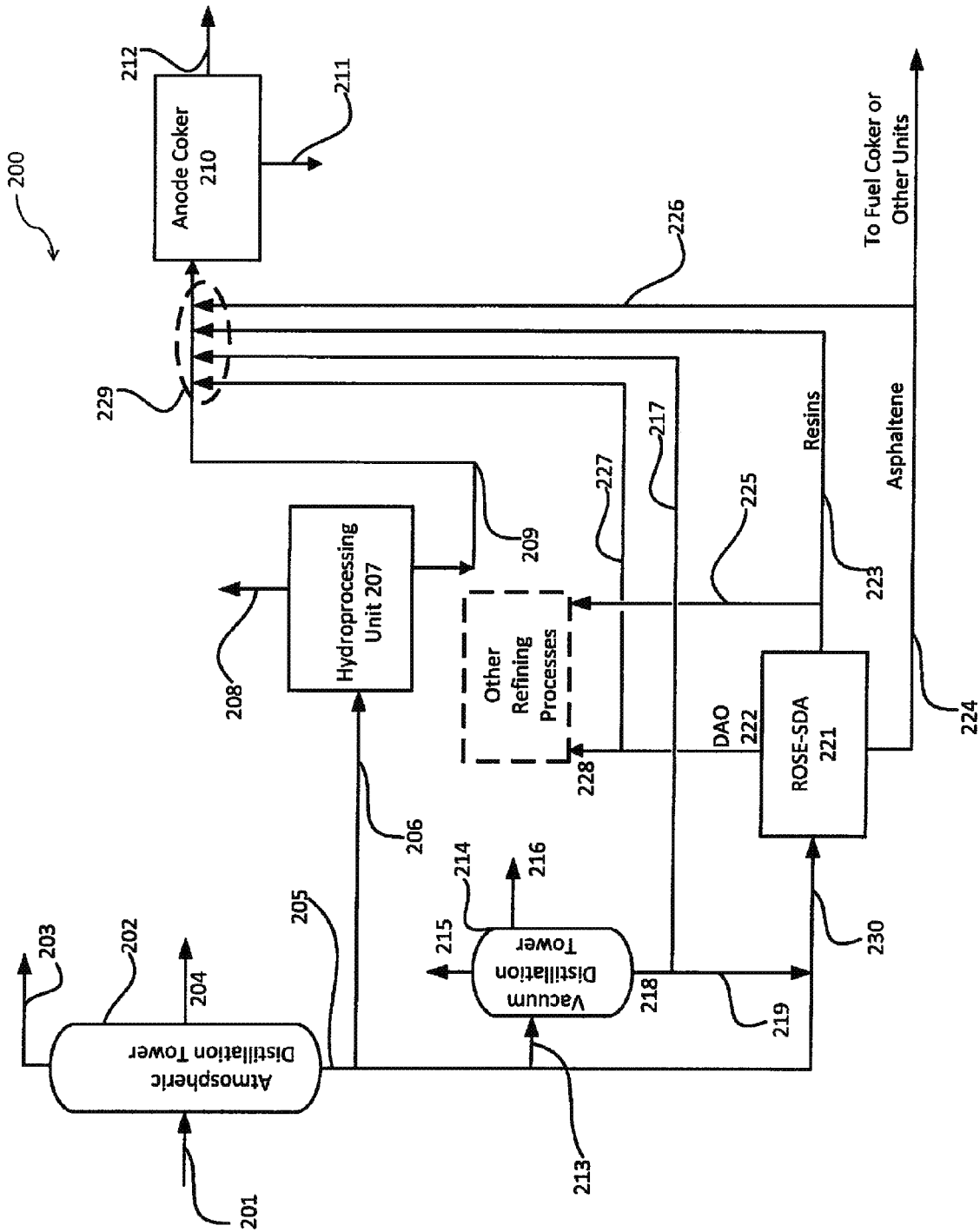

FIG. 2

Table 2

	301	302	303	304	305	306	307	308 (Klb / Day)
Arab Heavy Crude	24.1	13.2	1.3	11.9	20.6	9.2	2.7	1215
Arab Medium Crude	22.9	13.0	2.6	10.4	19.6	8.1	2.3	1125
Arab Light Crude	10.5	11.1	0	11.1	9.2	8.7	2.5	474
Arab Light Crude*	12.6	10.4	2.6	7.8	11.1	6.1	1.7	621

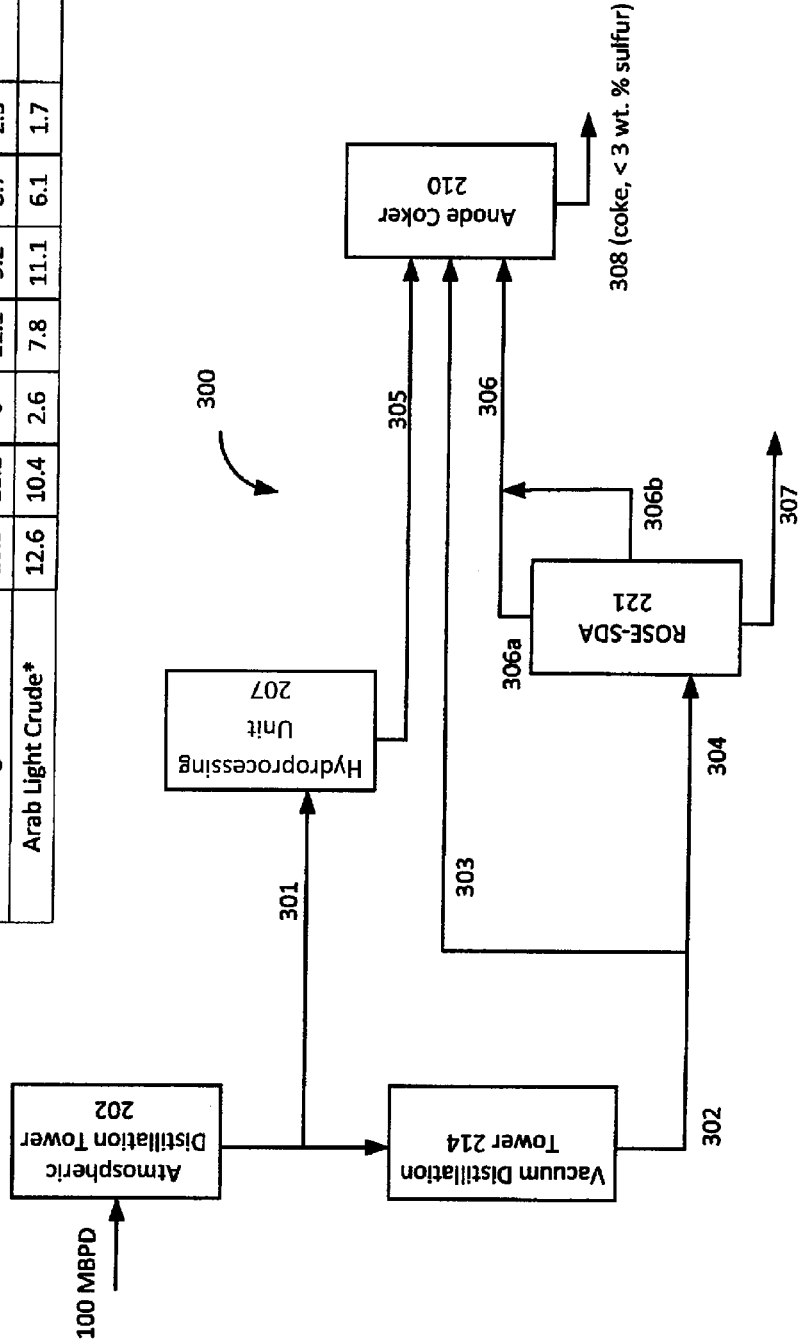

FIG. 3

SYSTEMS FOR PRODUCING ANODE GRADE COKE FROM HIGH SULFUR CRUDE OILS

CROSS REFERENCE TO RELATED APPLICATION

[0001] This application claims priority to U.S. Provisional Patent Application having Ser. No. 62/340,172 filed on May 23, 2016, which is incorporated by reference herein.

FIELD OF THE INVENTION

[0002] The present invention relates generally to the field of refining and more particularly to methods for making anode grade coke from crude oil with high levels of sulfur.

BACKGROUND

[0003] Crude oil is a complex mixture of thousands of chemical species, most of which are hydrocarbons, i.e., they are made of carbon and hydrogen. Some chemical species in crude oil contain other elements (referred to as “hetero elements”), such as sulfur, nitrogen, or metals such as vanadium or nickel. Crude oils from different locations on the earth have vastly different composition; the types and relative amounts of compounds they contain can vary greatly. For example, “heavy” crude oils contain a relatively higher amount of large hydrocarbon molecules whereas “light” crude oil contains a relatively higher amount of small hydrocarbon molecules. “Sweet” crude oil contains little sulfur (typically less than about 0.5 weight percent) whereas “sour” crude oil contains a higher amount of sulfur (typically 1-2 weight percent or more).

[0004] Crude oil itself is generally not very useful; it must be refined and processed to yield valuable products. Refining and processing involves subjecting the crude oil to various separations and chemical reactions that ultimately yield a spectrum of useful products such as transportation fuels (aviation gasoline, automobile gasoline, and diesel fuel), heating oil, and kerosene, asphalt and petroleum coke.

[0005] The highest value products, such as transportation fuels, are typically obtained in the highest quantities and with the least effort from light sweet crude oils. However, light sweet crude oil sells at a premium because of its desirability. The high price of light sweet crude oil has incentivized efforts to obtain valuable petroleum products from lower grades of crude oil, i.e., heavier crude oil having more sulfur and metals. Such crude oils require more complex refining and processing.

[0006] Petroleum coke (also referred to as petcoke and referred to herein simply as coke) is a high carbon product of petroleum refining. Coke is obtained by heating the heavy residue left over from distillation processes (also referred to as resid) in the presence of steam to produce a solid, carbonaceous material. The marketability of coke depends on the amount of sulfur it contains. Coke with a relatively high sulfur content is referred to as fuel grade coke and is sold as fuel for coal-burning boilers, typically for power generation. Coke with a relatively low sulfur content can be used to make electrodes that are valuable for use in dry cells and in industrial electrical process, such as the production of aluminum.

[0007] Anode grade coke generally must have a sulfur content less than 3 weight percent, a nickel content less than 200 ppm, a vanadium content less than 350 ppm and a total

metals content less than 500 ppm. In addition to heteroatom content, anode grade coke is subject to other constraints. For example, anode grade coke that is suitable for making carbon anodes suitable for aluminum manufacture preferably has an HGI grindability index greater than 70, a bulk density of at least 50 lbs/ft³, and a volatile carbonaceous material content of less than 10 or 12 weight percent. It is more desirable to produce anode grade coke since this is a higher value product than fuel grade coke. Anode grade coke is about three to five times more valuable than fuel coke.

[0008] The quality of crude oil that a refining process uses as a feedstock largely determines the grade of coke obtained from the process. Light sweet crude produces a higher yield of anode grade coke. However, as economic forces drive refiners to using heavier and more sour crude, anode grade coke is more difficult to obtain. The distillation of the crude tends to concentrate sulfur and other contaminants into the resid.

[0009] Hydroprocessing generally refers to hydrotreating and hydrocracking processes. Hydroprocessing is a method of improving the quality of distillate products and occasionally treating residues from distillation processes. Hydroprocessing involves reacting the distillate products and at times residue from distillation with hydrogen in the presence of a catalyst to remove sulfur. Hydrocracking is used to convert the high boiling distillates and at times petroleum residue into a higher proportion of more valuable lower-boiling products. The residue remaining after the lower-boiling products are removed from the hydroprocessing unit effluent generally has a lower sulfur and metal content.

[0010] It has been suggested to hydrotreat the distillate residues obtained from high sulfur crude to remove the sulfur and provide a higher grade of coke. Unfortunately, hydrotreating of the petroleum residue affects the physical characteristics of the resulting resid, rendering it unsuitable for the anode manufacturing process. Therefore, for the production of anode grade coke, feedstocks have been historically limited to virgin residues with inherently low sulfur and metals content.

[0011] There is a need, therefore, for improved methods of processing lower grade crude to obtain higher amounts of valuable products, such as anode-grade coke.

BRIEF DESCRIPTION OF THE DRAWINGS

[0012] FIG. 1 illustrates a generic refining process, as known in the prior art.

[0013] FIG. 2 depicts a refining process including a hydrotreating unit and a ROSE-SDA for providing a synthetic product stream to an anodic coking unit.

[0014] FIG. 3 depicts a schematic illustration of a process as illustrated in FIG. 2 operated under four different conditions.

DETAILED DESCRIPTION

[0015] FIG. 1 illustrates a simplified generic refining process 100 according to the prior art. A crude oil feed stream 101 enters an atmospheric distillation tower 102. Atmospheric distillation produces an overhead stream 103 comprising gas components and one or more light liquid streams 104 comprising components such as naphtha, kerosene, and gas oil. The streams 103 and 104 from the atmospheric distillation tower feed into further refining processes 105 to produce a range of products 106. The

further refining processes **105** are not particularly relevant in the instant disclosure and are not discussed further. The bottom stream **107** from the atmospheric distillation tower feeds into a vacuum distillation tower **108**. Distillates exit the vacuum distillation tower **108** via one or more streams **109** for further refining. The bottom stream **110** of the vacuum distillation tower **108** feeds into a coker or a coking unit **111**. The bottom stream **110** generally contains large concentrations of resins asphaltenes and heteroatom compounds such as compounds containing sulfur, nitrogen, oxygen and metals. Heavy streams **112** from other processes can feed into the coking unit **111** for further process. Coking results in one or more products such as naphtha, light oil, or heavy oil, which exit the coking unit **111** via stream **113**. Coke exits the coking unit **111** via stream **114**.

[0016] As explained above, the coke produced by the coking unit **111** is preferably low in sulfur content for the coke to be useful as anode materials. When the crude feedstock **101** has a high sulfur content, the resulting coke generally also has a high sulfur content, rendering it unsuitable as an anode material. The coke thus produced therefore is not as valuable.

[0017] FIG. 2 illustrates an embodiment **200** of the process disclosed herein for producing anode grade coke from high sulfur crude oils. A stream of high sulfur crude **201** enters an atmospheric distillation tower **202** and is separated into an overhead stream **203** (typically liquefied petroleum gas, LPG), one or more mid-distillate product streams **204**, and an atmospheric distillation tower bottoms stream **205** which includes mostly resid. A portion **206** of the atmospheric distillation tower bottoms stream **205** feeds into a hydroprocessing unit or a hydrotreating unit **207**.

[0018] Sulfur removal by hydroprocessing (hydrotreating and/or hydrocracking) is well known in the art. The hydroprocessing unit **207** can generally be any type of hydrogen addition unit known in the art, for example, a Fixed bed unit, a slurry-phase unit, or an ebullated bed unit. Hydroprocessing unit **207** may be a once through unit, a single stage recycle, or a multi-stage unit. The hydroprocessing process may use one or more of multiple commonly used catalysts using Nickel, Cobalt, Molybdenum, or noble metals.

[0019] The hydroprocessing unit **207** produces one or more product streams **208** (typically containing jet fuel, diesel, low sulfur fuel oil (LSFO), and/or naphtha) and bottoms stream **209** (typically containing desulfurized resid). The hydroprocessing unit bottoms stream **209** (also referred to as hydrotreated resid) is provided to an anode coking unit **210**. The anode coking unit **210** can generally be any type of coking unit known in the art, but is typically a delayed coking unit. The anode coking unit **210** may include one or more pairs of drums, for example, one pair, two pairs, three pairs, four pairs, or more, as is known in the art. The anode coking unit **210** produces low sulfur anode-grade coke (stream **211**) and one or more product streams **212** (containing products such as naphtha and light and heavy coker gas oils).

[0020] A second portion **213** of the atmospheric distillation tower bottoms stream **205** feeds into a vacuum distillation tower **214**, where it is separated into a vacuum tower overhead stream **215** (LPG), one or more mid-distillate streams **216** (heavy and/or light vacuum gas oil, gasoline), and a vacuum distillation tower bottoms stream **218** (resid). A portion **217** of the vacuum distillation tower bottoms **218** can be blended with the stream **209** from the hydroprocess-

ing unit **207** and fed to the anode coker **210**. Another portion **219** of the vacuum distillation tower bottoms stream **218** can be blended with the atmospheric distillation tower bottoms stream **205** to provide a feed **230** to a solvent deasphalting unit **221**. The solvent deasphalting unit **221** may be a three-product solvent deasphalting unit such as a three-product residuum oil supercritical extraction-solvent deasphalting (ROSE-SDA) unit.

[0021] ROSE-SDA is described in US 2011/0094937 ("the '937 publication"). According to certain embodiments, a three-product ROSE-SDA unit, as illustrated in FIG. 2 of the '937 publication and described at paragraphs [0066]-[0085] of the '937 publication (the referenced contents of which are hereby incorporated herein by reference), is used for solvent deasphalting.

[0022] In the embodiment illustrated in FIG. 2, feed **230** to the deasphalting unit **221** includes a portion of the atmospheric distillation tower bottoms stream **205** and a portion **219** of the vacuum distillation tower bottoms stream **218**. It should be noted, however, that in other embodiments, the feed **230** to the solvent deasphalting unit may include only one or the other of streams **205** and **218**.

[0023] The solvent deasphalting unit **221** produces a top stream **222** (containing deasphalted oil a.k.a. light deasphalted oil, (L-DAO)), one or more streams **223** (containing heavy deasphalted oil (H-DAO), a.k.a., resin), and a bottom stream **224** (primarily containing asphaltenes). According to some embodiments, a portion **225** of stream **223** (resin) and/or a portion **228** of stream **222** (L-DAO) can be routed to other processes within the refinery for blending or other further processing. It should be noted that one such other processes can include hydroprocessing, such as by hydrotreating and or hydrocracking unit(s) **207**.

[0024] A portion of stream **223** (resin), a portion **226** stream **224** (asphaltenes), and/or a portion **227** of stream **222** (L-DAO) can be blended with the hydroprocessing unit product stream **209** to produce a synthetic stream **229** as feed to the anode coking unit **210**. The specific composition of stream **229** can be adjusted to 1) provide adequate quality material for making anode-grade coke, while 2) optimizing the economics of the upstream processes (i.e., energy use, catalyst use and lifetime, yield of high value products, etc.).

[0025] The availability of multiple streams of processed tower bottoms for anode coking overcomes several of the difficulties mentioned in the Background section. As described in the Background section, the feedstock for producing anode grade coke must be low in sulfur and metals content. Hydrotreating a portion of the atmospheric distillation tower bottoms stream (portion **206** in FIG. 2) can provide a stream **209** that is well within the sulfur and metals concentration tolerances for anode coking as well as providing an overhead stream **208** of lighter, more valuable components. However, as mentioned above, hydrotreated resid generally yields coke not meeting the physical specifications (an HGI grindability index greater than 70, a bulk density of at least 50 lbs/ft³, and a volatile carbonaceous material content of less than 10 or 12 weight percent) for anode grade coke.

[0026] Another drawback of hydroprocessing residual oil to remove sulfur and metals is that it is a severe process, requiring intensive hydrogenation (using large amounts of hydrogen), a great amount of energy, frequent catalyst replacement. Relying on hydroprocessing of atmospheric distillation tower bottoms and vacuum distillation tower

bottoms as the sole source of the feedstock for the coking unit is prohibitively expensive.

[0027] The process **200** illustrated in FIG. 2 does not suffer from those drawbacks because the hydroprocessing unit is not used to remove sulfur and heavy metals from the entire resid feedstock for the anodic coking unit. Instead, process **200** provides multiple resid streams that can be blended into a feed **229** for the anodic coking unit. Each of the streams can have different sulfur and heavy metals concentrations. Each of the streams also may have a different cost associated with producing that stream.

[0028] For example, stream **209** has a very low sulfur and metals content but is also relatively expensive to produce, due to the costs associated with operating the hydroprocessing unit. Likewise, the amount of sulfur and metals in stream **217** may exceed the amount specified for feed to the anodic coker, but stream **217** is much less expensive to produce than stream **209** (on a barrel per day basis). By blending streams **209** and **217** together, it may be possible to produce a stream that is both within specification for anodic coking unit and is also economically feasible. Generally, stream **209** has the lowest sulfur/metal concentration but is the most expensive and stream **217** has the highest sulfur/metal concentration but is the least expensive. Streams **227**, **223**, and **226** are intermediate in both costs and sulfur content.

[0029] Reducing the resid-treating demand of the hydroprocessing unit **207** allows the unit to be operated more economically without bottlenecking the resid-treating process. Since the hydroprocessing unit **207** has less resid to treat, it can be operated under less severe conditions and uses less hydrogen and catalyst. Catalyst lifetimes can be extended. Moreover, the hydroprocessing unit **207** (which typically must be made of specialized and expensive metallurgical materials) can be smaller (and therefore less costly to build).

[0030] The process **200** described above is re-illustrated as a more simplified schematic **300** in FIG. 3 for providing relative amounts of material in the various streams in the process. For clarity, several of the overhead streams illustrated in FIG. 2 are omitted in FIG. 3. Based on a crude feed of 100,000 barrels per day (100 MBPD), the following are typical ranges for the amounts of material in each of the streams: 5-35 MBPD in stream **301**; 5-30 MBPD in stream **302**; 0-15 MBPD in stream **301** 5-30 MBPD in stream **304**; 2-25 MBPD in stream **305**; 1.5-20 MBPD in stream **306** (typically with a 1.5-20 MBPD contribution of deasphalted oil via stream **306a** and a 0-15 MBPD contribution of resin via stream **306b**); 2-25 MBPD in stream **307** and 2-20 MBPD in stream **308**.

[0031] A person of skill in the art will recognize that the relative amounts of material in each stream can be adjusted depending on the various considerations, including the amount of sulfur in the crude feed material. Table 1 lists the approximate amount of sulfur in three grades of Arab Crude Oil:

TABLE 1

Sulfur Content of Various Grades of Arab Crude Oil.	
Grade	Sulfur (%)
Arab Light	1.97
Arab Medium	2.59
Arab Heavy	2.87

[0032] Note that the amount of sulfur in each of the grades of Arab Crude Oil becomes much more concentrated in the residues from the atmospheric distillation tower and the vacuum distillation tower.

[0033] Table 2, illustrated in FIG. 3, lists the amount of material directed through each of the streams of process **300** under various operating conditions. Column **308** of Table 2 lists the amount (in KLb/Day) of anodic coke produced by anode coking unit **210** under each of the operating conditions. The relative amounts of materials in streams **301** and **304** are greater for the Arab Heavy Crude than for the other grades of crude. Arab Heavy Crude contains more sulfur and therefore requires more hydrotreating and/or solvent deasphalting to yield anodic coke.

[0034] Another notable observation from Table 2 is the increased anodic coke yield when vacuum distillation tower residue is mixed into the anodic coking unit feed stream. In the first example of processing Arab Light Crude, no vacuum tower residue is fed directly to the anodic coking unit (i.e., no material is provided via stream **303**). That processing operation yields 474 KLb/day of anodic coke. But when 2.6 MBPD of vacuum tower residue is fed to the anodic coking unit, the production of anodic coke increases to 621 KLb/day.

[0035] Certain embodiments and features have been described using a set of numerical upper limits and a set of numerical lower limits. It should be appreciated that ranges including the combination of any two values, e.g., the combination of any lower value with any upper value, the combination of any two lower values, and/or the combination of any two upper values are contemplated unless otherwise indicated. Certain lower limits, upper limits, and ranges appear in one or more claims below. All numerical values are “about” or “approximately” the indicated value, and take into account experimental error and variations that would be expected by a person having ordinary skill in the art.

[0036] Various terms have been defined above. To the extent a term used in a claim is not defined above, it should be given the broadest definition persons in the pertinent art have given that term as reflected in at least one printed publication or issued patent. Furthermore, all patents, test procedures, and other documents cited in this application are fully incorporated by reference to the extent such disclosure is not inconsistent with this application and for all jurisdictions in which such incorporation is permitted.

[0037] While the foregoing is directed to embodiments of the present invention, other and further embodiments of the invention may be devised without departing from the basic scope thereof; and the scope thereof is determined by the claims that follow.

What is claimed is:

1. A system for producing anode grade coke comprising: a vacuum distillation tower, a hydroprocessing unit, a solvent deasphalting unit; and an anode coker; wherein feed to the anode coker comprises bottoms from the vacuum distillation tower, hydrotreated resid from the hydroprocessing unit, and a stream from the deasphalting unit.
2. The system of claim 1, wherein feed to the solvent deasphalting unit comprises bottoms from the vacuum distillation tower.
3. The system of claim 1, further comprising an atmospheric distillation tower.

4. The system of claim 3, wherein feed to the hydroprocessing unit comprises bottoms from the atmospheric distillation tower.

5. The system of claim 3, wherein feed to the solvent deasphalting unit comprises bottoms from the atmospheric distillation tower.

6. The system of claim 1, wherein the solvent deasphalting unit comprises a residuum oil supercritical extraction process.

7. The system of claim 1, wherein the stream from the deasphalting unit comprises a resins stream.

8. The system of claim 1, wherein the stream from the deasphalting unit comprises a deasphalted oil stream.

9. The system of claim 1, wherein the stream from the deasphalting unit comprises two or more of a deasphalted oil stream, a resins stream, and an asphaltene stream.

10. The system of claim 1, wherein the anode coker is configured to produce anode grade coke.

11. The system of claim 1, wherein the anode coker is configured to produce coke comprising less than 3 wt. % sulfur.

12. A method for producing anode grade coke, comprising:

blending a synthetic feed stream, the synthetic stream comprising hydrotreated resid and one or more streams from a solvent deasphalting unit, and providing the synthetic feed stream to a coker unit.

13. The method of claim 12, wherein the hydrotreated resid comprises hydrotreated atmospheric distillation tower bottoms.

14. The method of claim 12, wherein the one or more streams from a solvent deasphalting unit comprises one or more resin streams.

15. The method of claim 12, wherein the one or more streams from a solvent deasphalting unit comprises deasphalted oil.

16. The method of claim 12, wherein the one or more streams from a solvent deasphalting unit comprises asphaltene.

17. The method of claim 12, wherein the one or more streams from a solvent deasphalting unit comprises at least of deasphalted oil, resins, and asphaltene.

18. The method of claim 12, wherein the synthetic stream further comprises vacuum distillation tower bottoms.

19. The method of claim 12, wherein the anode anode grade coke comprises less than 3 wt. % sulfur.

20. The method of claim 12, wherein the solvent deasphalting unit comprises a residuum oil supercritical extraction process.

* * * * *