



(19) **United States**

(12) **Patent Application Publication**
McSchooler

(10) **Pub. No.: US 2017/0339067 A1**

(43) **Pub. Date: Nov. 23, 2017**

(54) **SYSTEMS, METHODS AND APPARATUS FOR RESTRICTING NETWORK ACCESS**

(52) **U.S. CL.**
CPC **H04L 47/808** (2013.01); **H04L 67/22** (2013.01); **H04L 67/306** (2013.01)

(71) Applicant: **EchoStar Technologies L.L.C.**,
Englewood, CO (US)

(57) **ABSTRACT**

(72) Inventor: **Jeffrey McSchooler**, Parker, CO (US)

Various embodiments of systems, apparatus, and/or methods are described for restricting user devices from accessing a communication network. In one implementation, multiple user devices are assigned to a user profile. At least one access parameter is designated for the user profile. An access device monitors data usage, time usage, and content usage of each of the devices associated with the user profile. In some examples, the access device may consolidate the data usage and time usage of all of the devices. If one or more of the consolidated data usage, consolidated time usage, or content usage violates the access parameter of the user profile, the access device restricts at least one of the multiple user devices from accessing the communication network.

(21) Appl. No.: **15/157,751**

(22) Filed: **May 18, 2016**

Publication Classification

(51) **Int. Cl.**
H04L 12/927 (2013.01)
H04L 29/08 (2006.01)

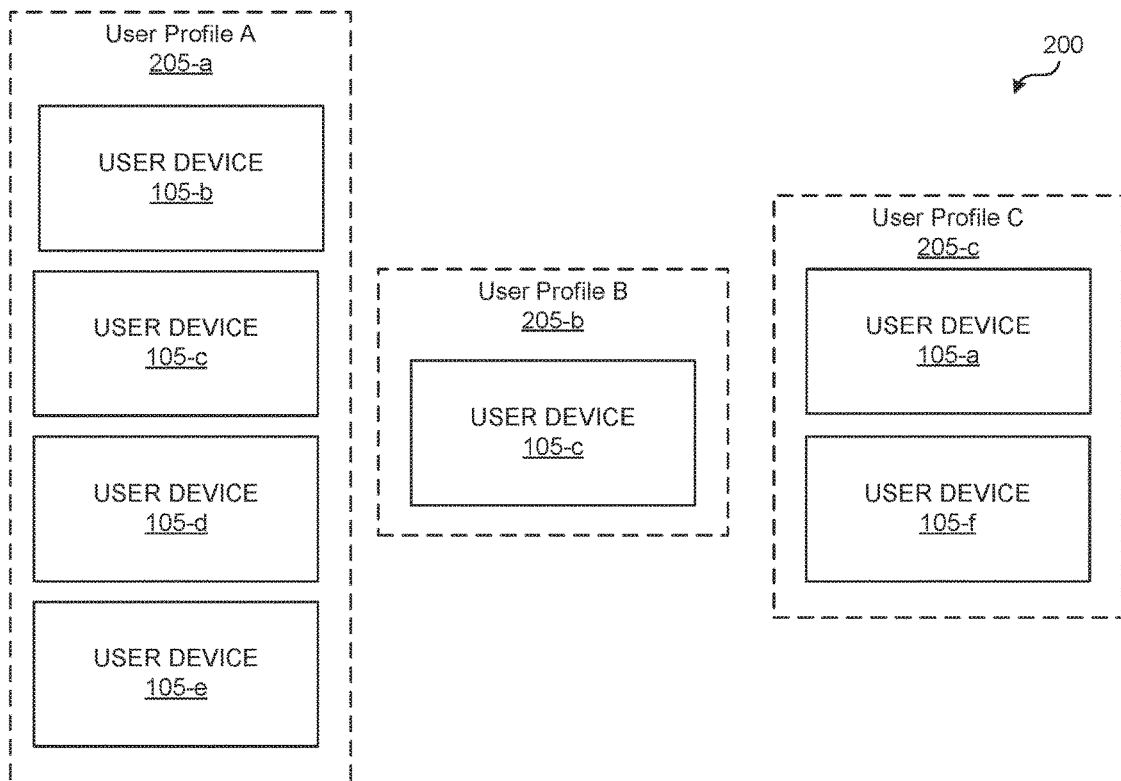

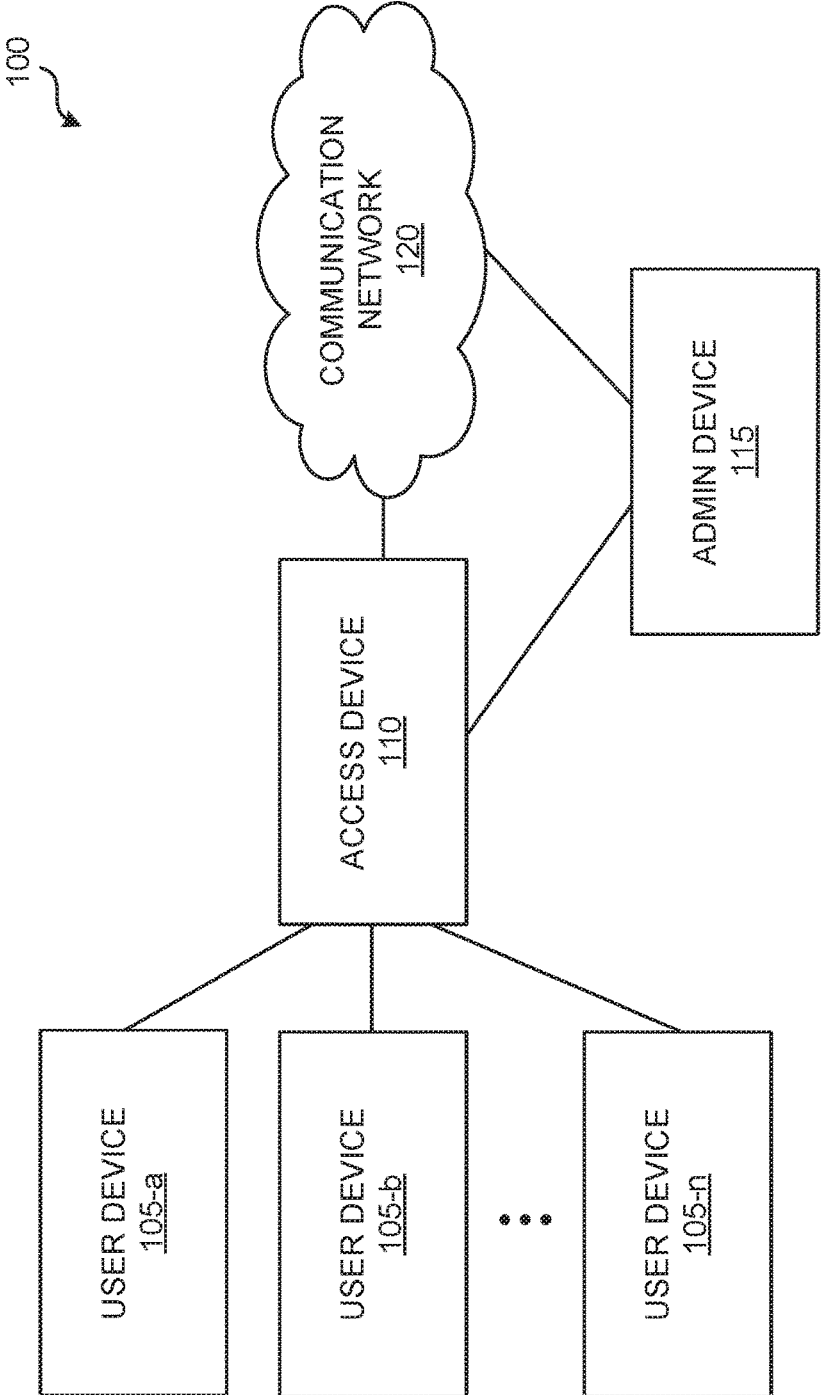

FIG. 1

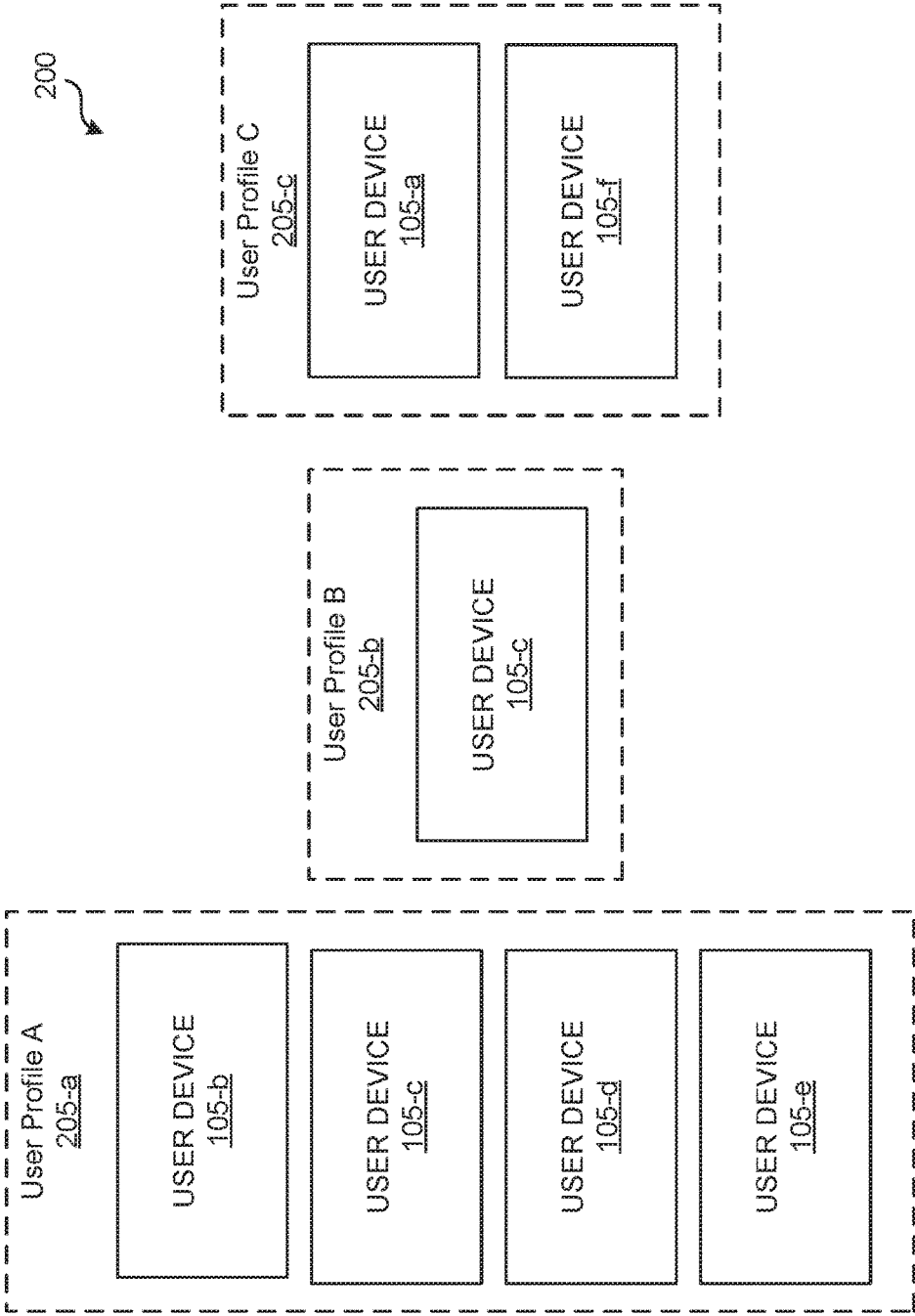

FIG. 2

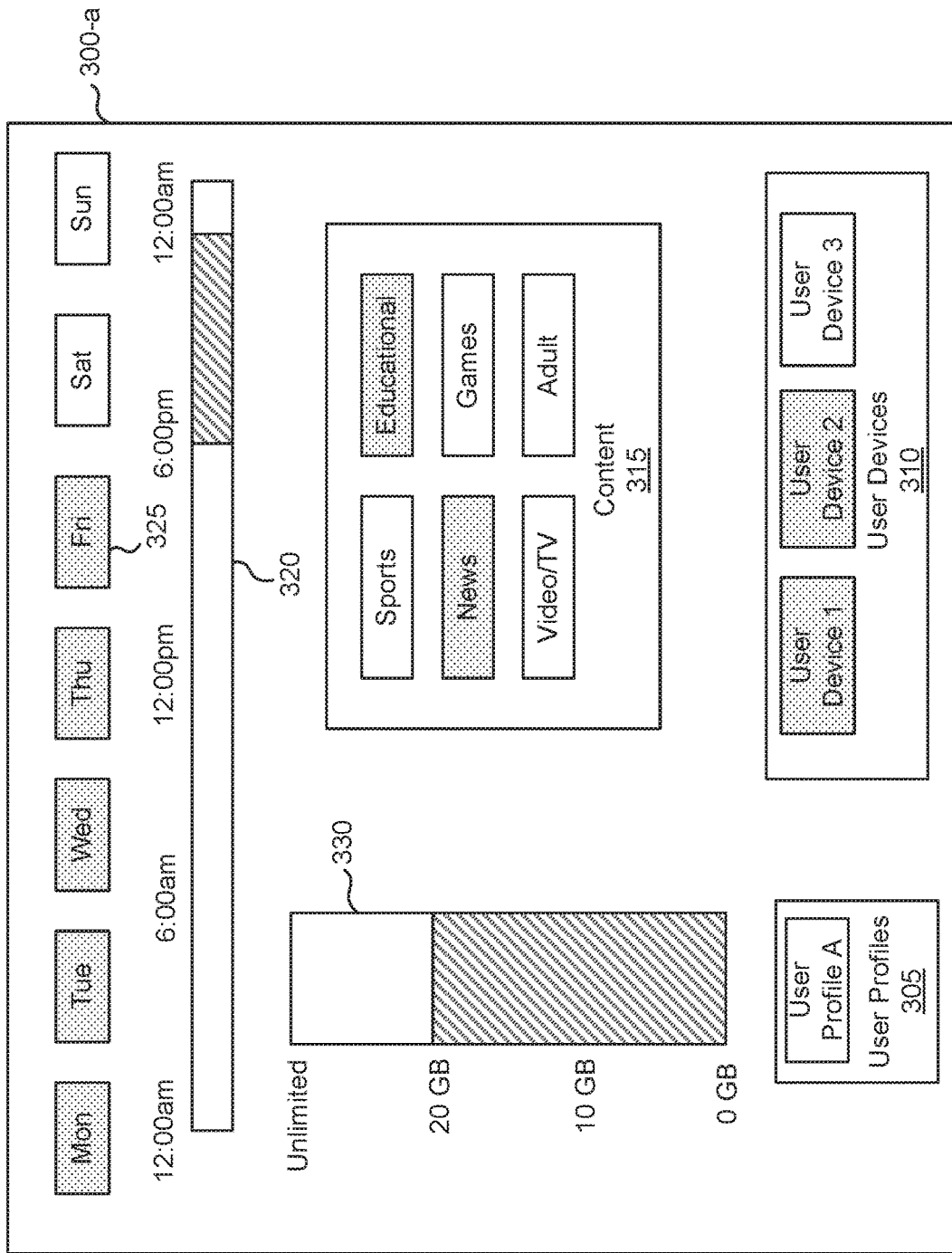

FIG. 3A

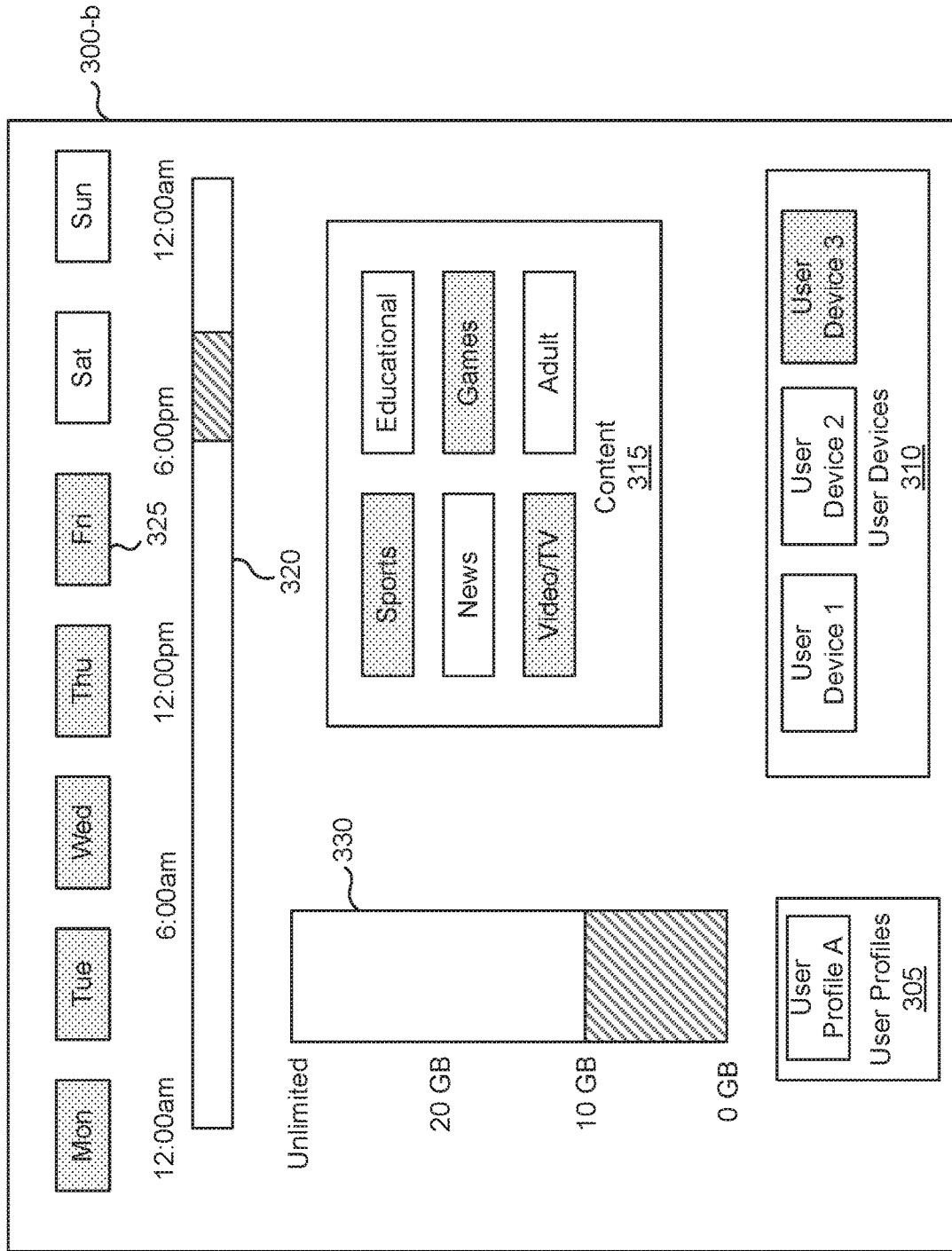

FIG. 3B

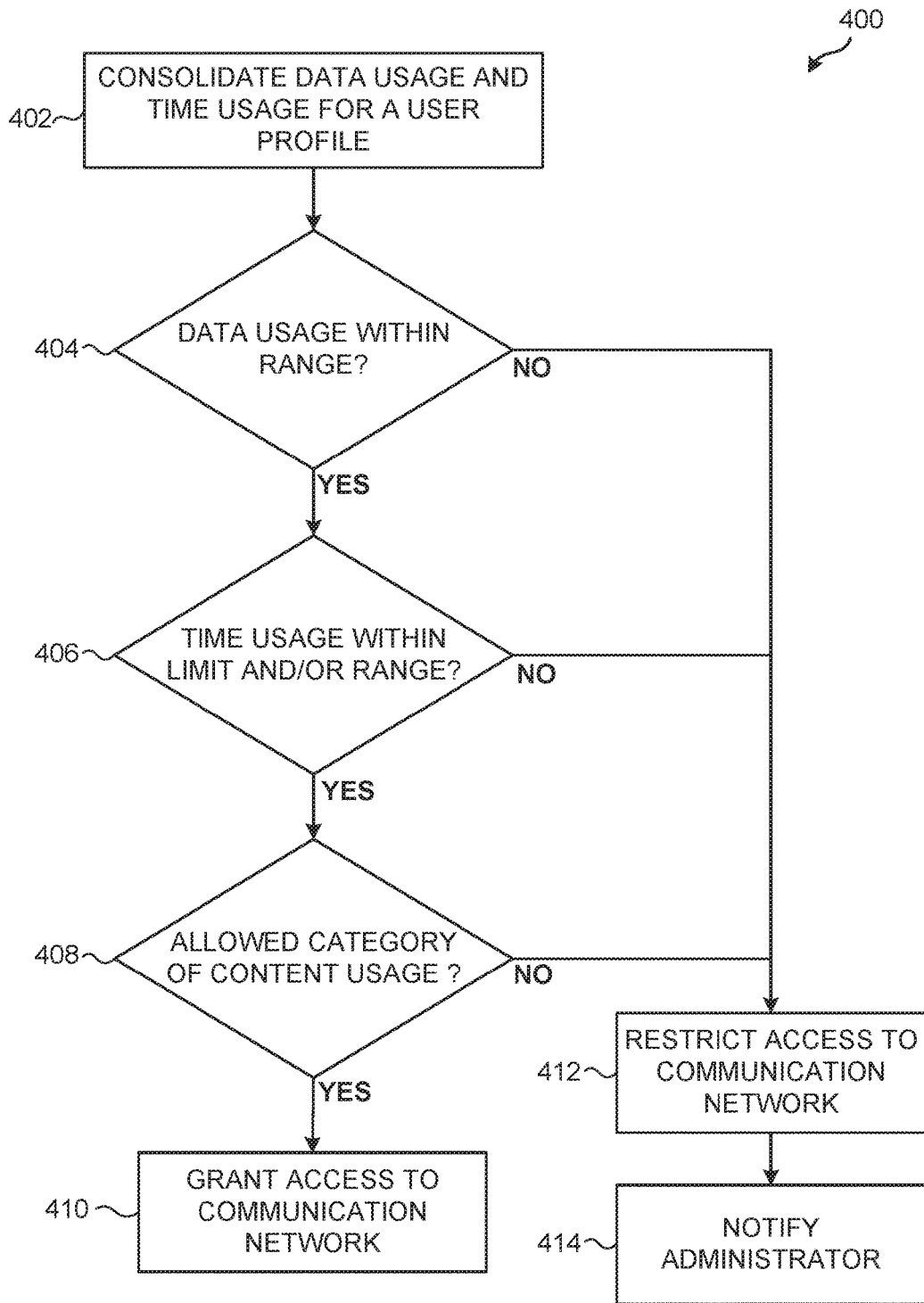

FIG. 4

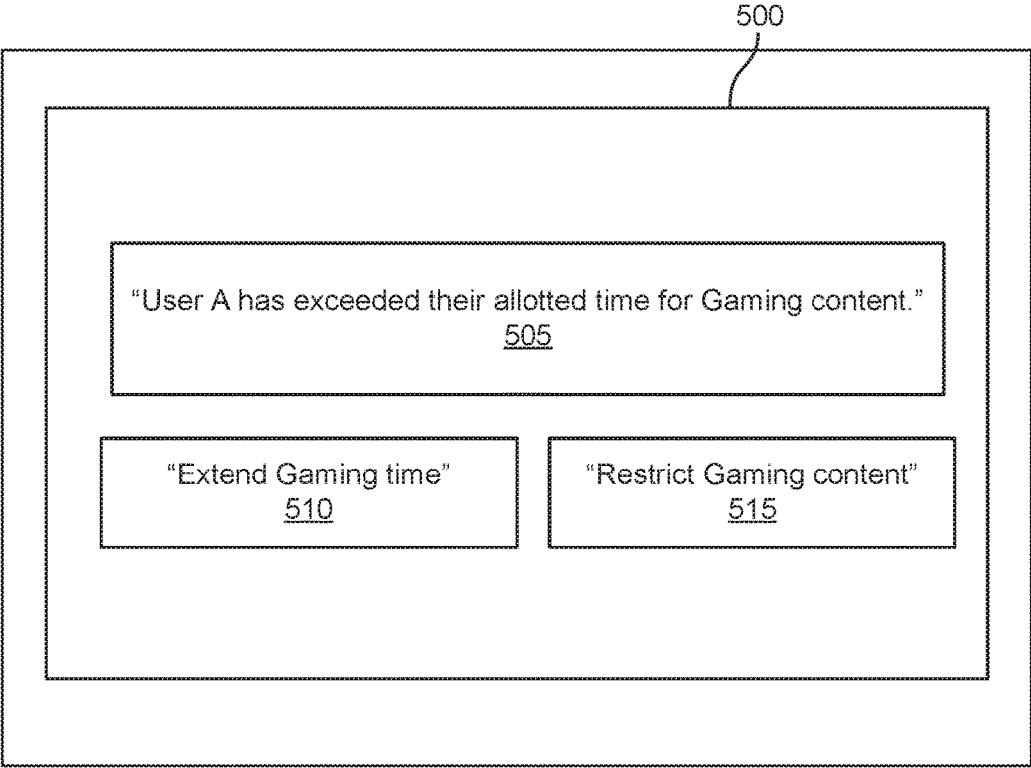

FIG. 5

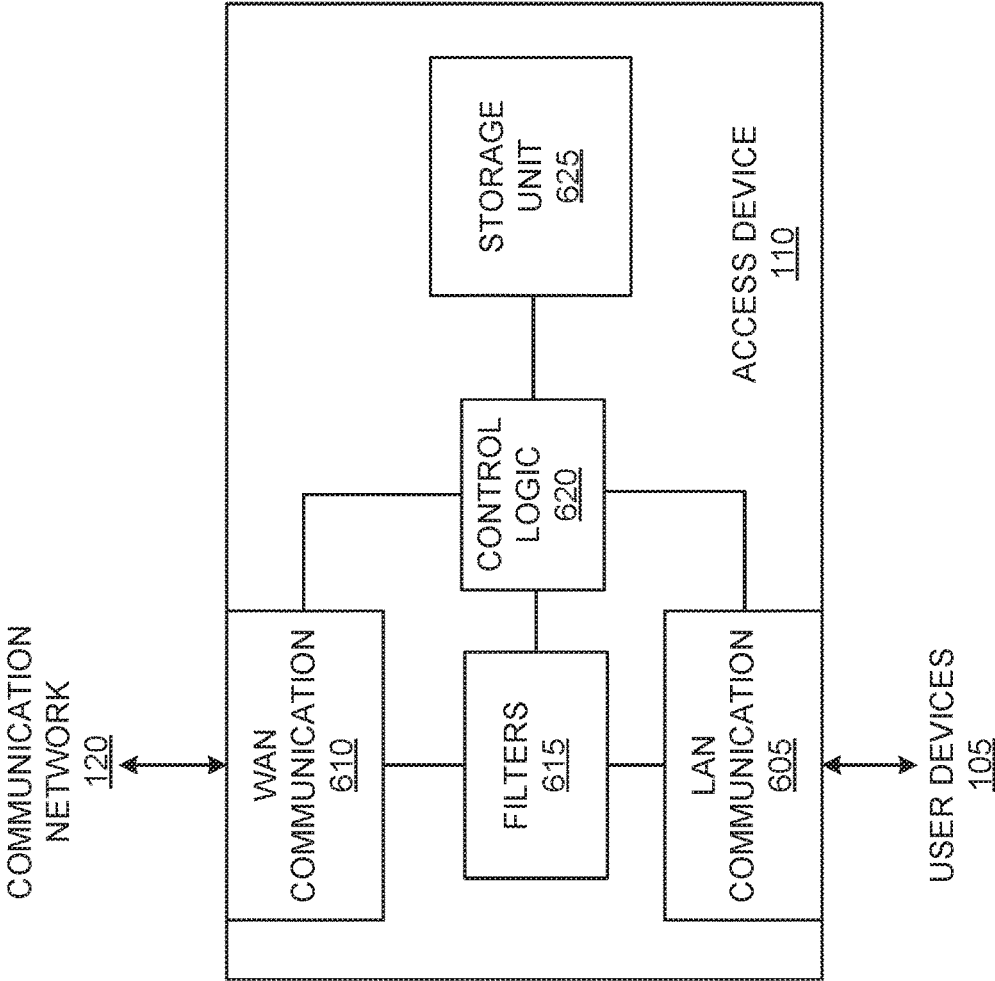

FIG. 6

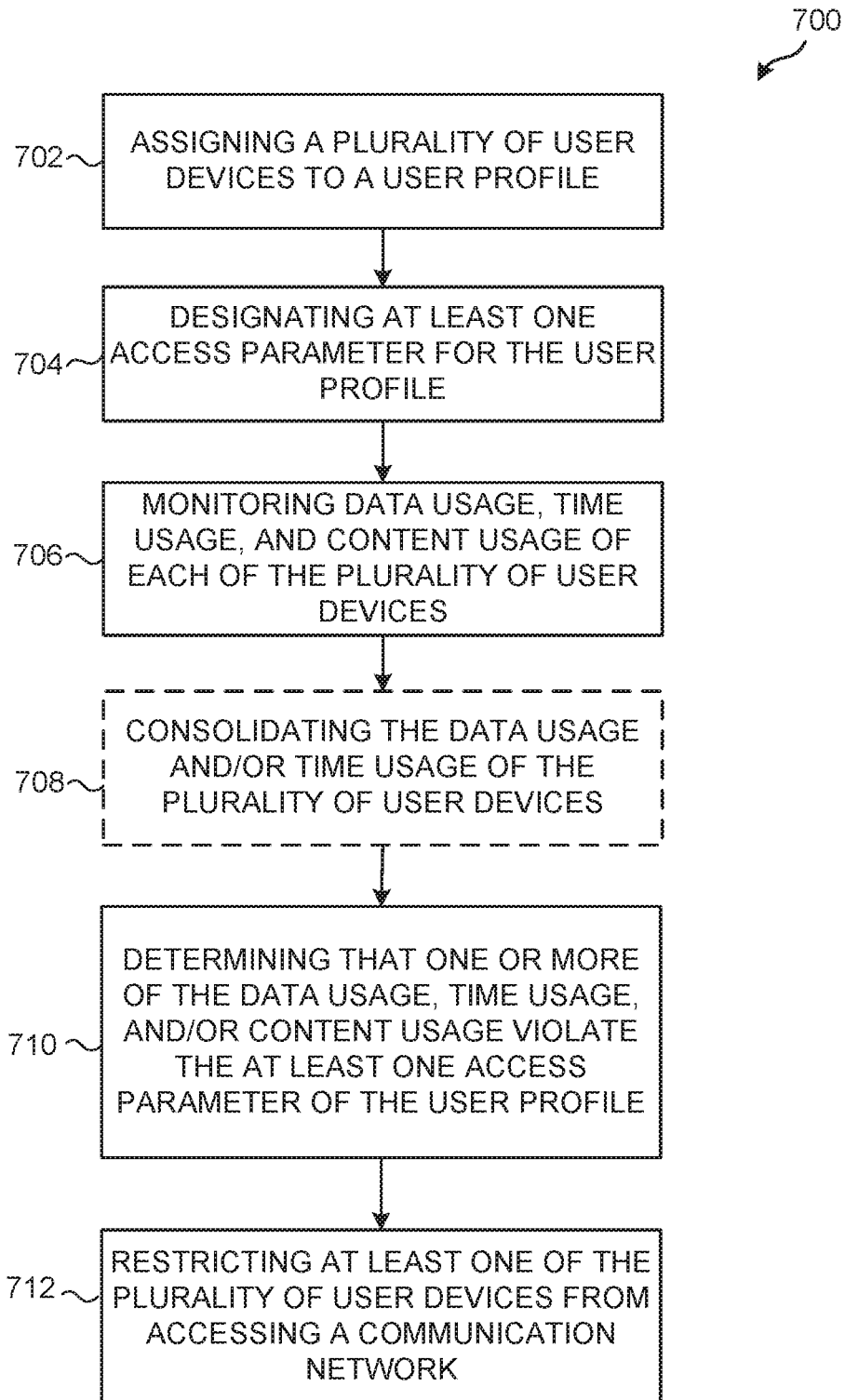

FIG. 7

SYSTEMS, METHODS AND APPARATUS FOR RESTRICTING NETWORK ACCESS

BACKGROUND

[0001] Parents, schools and businesses may utilize content filtering technology that automatically identifies and filters (i.e., blocks) access to certain content. Filters can be implemented in many different ways, such as with software on a personal computer, or via network infrastructure such as routers, proxy servers, DNS servers, firewalls, or other devices that provide network access. Filters that are part of network infrastructure often subject all users connected to the network infrastructure to the same access policies. Whereas software-based filters on a personal computer may be customized, but must be installed on every device where filtering is desired.

SUMMARY

[0002] The present disclosure relates to systems, methods, and apparatus for controlling internet access. In one implementation, the method includes assigning a plurality of user devices to a user profile; designating at least one access parameter for the user profile; monitoring data usage, time usage, and content usage of each of the plurality of user devices; determining that one or more of the data usage, time usage, or content usage violate the at least one access parameter of the user profile; and restricting at least one of the plurality of user devices from accessing a communication network.

[0003] In some examples, the at least one access parameter includes one or more of a data usage limit, a time usage limit, a time usage range, and content categories. In some examples, the method further includes notifying an administrator device when at least one of the plurality of user devices is restricted from accessing the communication network. In some examples, the notification comprises one or more of a visual notification, an audio notification, and a tactile notification. In some examples, the notification comprises an indication of the at least one access parameter that was violated. In some examples, the method further includes receiving an instruction from the administrator device to allow the at least one of the plurality of user devices to continue accessing the communication network.

[0004] In some examples, the method further includes consolidating the data usage and time usage of the plurality of user devices. In some examples, consolidating the data usage comprises summing the total data used by the plurality of user devices. In some examples, consolidating the time usage comprises summing the total time the plurality of user devices have been used. In some examples, the content usage comprises one or more categories of content accessed by the plurality of user devices. In some examples, the method further includes designating two or more access parameters for the user profile; and determining that two or more of the data usage, time usage, or content usage violate two or more of the access parameters.

[0005] In one implementation, the access device includes a local area network (LAN) communication module in communication with a plurality of user devices; a wide area network (WAN) communication module in communication with an external network; at least one filter to selectively restrict communications between the plurality of user devices and the external network; a storage unit to store at

least one user profile associated with the plurality of user devices and at least one access parameter for the at least one user profile; and a control logic to configure the at least one filter based on the user profile and the at least one access parameter, wherein the control logic monitors data usage, time usage, and content usage of each of the plurality of user devices and consolidates the data usage and time usage of the plurality of user devices, and wherein the at least one filter restricts at least one of the plurality of user devices from accessing the external network based on one or more of the consolidated data usage, consolidated time usage, or content usage violating the at least one access parameter.

[0006] In some examples, the control logic is configured to notify an administrator device when at least one of the plurality of user devices is restricted from accessing the communication network. In some examples, the control logic is configured to receive an instruction from the administrator device to allow the at least one of the plurality of user devices to continue accessing the communication network. In some examples, the control logic is configured to consolidate the data usage and time usage of the plurality of user devices. In some examples, the storage unit stores two or more access parameters for the user profile, and the at least one filter restricts at least one of the plurality of user devices from accessing the external network based on two or more of the data usage, time usage, or content usage violating two or more of the access parameters.

[0007] It is to be understood that both the foregoing summary and the following detailed description are for purposes of example and explanation and do not necessarily limit the present disclosure. The accompanying drawings, which are incorporated in and constitute a part of the specification, illustrate subject matter of the disclosure. Together, the descriptions and the drawings serve to explain the principles of the disclosure.

BRIEF DESCRIPTION OF THE DRAWINGS

[0008] The same number represents the same element or same type of element in all drawings.

[0009] FIG. 1 illustrates an example of a communications system, in accordance with various aspects of the present disclosure.

[0010] FIG. 2 illustrates an example of groupings of user devices, in accordance with various aspects of the present disclosure.

[0011] FIG. 3A is an example of a configuration interface for configuring access parameters for a user profile, in accordance with various aspects of the present disclosure.

[0012] FIG. 3B is another example of a configuration interface for configuring access parameters for a user profile, in accordance with various aspects of the present disclosure.

[0013] FIG. 4 is a flow diagram illustrating example operations of an access device, in accordance with various aspects of the present disclosure.

[0014] FIG. 5 illustrates an example of a display presenting a notification interface to an administrator, in accordance with various aspects of the present disclosure.

[0015] FIG. 6 illustrates an example of an access device, in accordance with various aspects of the present disclosure.

[0016] FIG. 7 is a flow diagram illustrating an example of a process for restricting access to a communication network, in accordance with various aspects of the present disclosure.

DETAILED DESCRIPTION OF THE DRAWINGS

[0017] The various embodiments described herein generally provide apparatus, systems and methods which facilitate access to one or more communication networks. More particularly, the various embodiments described herein provide for a parent or administrator to restrict one or more user devices from accessing particular content on a communication network.

[0018] FIG. 1 illustrates an example of a communications system 100, in accordance with various aspects of the present disclosure. In FIG. 1, a household or company may have multiple user devices 105a-105n. The user devices 105a-105n may be any hardware device that is capable of sending and receiving information over a communication network 120. Examples of user devices may include computers, mobile phones, PDAs, game consoles, televisions, set-top boxes, and the like. The communication network 120 may include one or more networks capable of connecting the user devices 105a-105n to entertainment content, informational content, and/or interactive content, such as the Internet, a cable distribution network, a satellite distribution network, a local area network, and the like.

[0019] An access device 110 provides the user devices 105a-105n with access to the communication network 120. The access device 110 may be a router (wired or wireless), an access point, a modem, or other device capable of providing multiple user devices with access to the communication network 120.

[0020] The access device 110 includes filters for restricting particular user devices from accessing particular content on the communication network 120. For example, the access device 110 may restrict one more user devices belonging to a child from accessing adult content. The access device 110 may also restrict particular user devices from accessing particular content during certain times or after certain durations of time. The access device 110 may also restrict particular user devices from accessing particular content based on the user devices based on the total data usage of the user devices. In some embodiments, the access device 110 restricts access based on the content accessed by multiple user devices belonging to (or assigned to) a user. The access device 110 may also restrict access based on a combination of conditions, such as accessing particular content during a certain time of day.

[0021] An admin device 115 configures the filters on the access device 110. The admin device 115 may be one or more of the user devices 105a-105n that belong or are assigned to a parent or administrator. Alternatively or in addition, the admin device 115 may be integrated into the access device 110, or may be software running on other computer or network devices. For example, a home router may include embedded software that allows it to operate as an admin device 115.

[0022] The admin device 115 has elevated privileges with the access device 110, which allows the admin device 115 to configure the filters for restricting access to other user devices 105a-105n. The admin device 115 may also receive notifications if one or more of the user devices 105a-105n trigger the access device 110 to restrict content and/or access to the communication network 120. The notifications may be sent from the access device 110 directly to the admin device 115, or the notifications may be sent via the communication network 120.

[0023] FIG. 2 illustrates an example of groupings 200 of user devices 105, in accordance with various aspects of the present disclosure. An administrator (or parent) may assign multiple user devices 105 to certain user profiles 205. Each user profile 205 may be associated with a particular user (such as a child, the administrator themselves, or a spouse). For example, a first user (such as an older child) may be associated with User Profile A 205a. The first user may regularly utilize four different user devices 105 to access the communication network 120. For example, user device 105b may be a personal computer, user device 105c may be a television, user device 105d may be a game console, and user device 105e may be a mobile phone. The administrator may assign each of the user devices 105b-105e to the User Profile A 205a associated with the first user. The access device 110 may then consolidate the time usage, data usage, and content usage across all of the devices utilized by the first user. Based on this consolidated usage, the access device 110 may restrict one or more of the user devices 105b-105e from accessing the communication network 120 and/or particular content on the communication network 120.

[0024] A second user (such as a younger child) may be associated with User Profile B 205b. The second user may only regularly utilize one user device 105c. The user device 105c may be, for example, a television. The administrator may assign the user device 105c to the User Profile B 205b associated with the second user. In this way, a user device 105 may be assigned to two different user profiles 205. The access device 110 may track the time usage, data usage, and content usage of the user device 105c separately for each user profile 205a and 205b.

[0025] The administrator (such as a parent) may be associated with User Profile C 205c. The User Profile C 205c may be designated as an administrator profile in the access device 110, which grants administrative privileges to the profile. The administrator may designate user device 105a and 105f as admin devices 115. User device 105a may be, for example, a mobile phone, and user device 105f may be, for example, a laptop computer. The administrator may utilize the user devices 105a or 105f to configure the access device 110, and to receive notifications from the access device 110. The administrator may also optionally set time usage, data usage, and/or content usage limits for the user device 105a and/or user device 105f.

[0026] The administrator may assign user devices 105 to user profiles 205 through an interface provided by the access device 110. For example, the access device 110 may present the administrator with a list of all user devices 105 connected to the access device 110. The administrator may then assign each user device 105 to one or more user profiles 205. In one embodiment, the administrator may create user profiles for each user accessing the communication network 120, and then assign each of the user devices 105 to the user profiles 205 by dragging and dropping each user device 105 to a user profile 205. The administrator may also assign each of the user devices 105 to the user profiles 205 by manually entering user device information into the user profiles 205.

[0027] FIG. 3A is an example of a configuration interface 300a for configuring access parameters for a user profile, in accordance with various aspects of the present disclosure. The configuration interface 300a may be transmitted from the access device 110 to an admin device 115, and displayed on the admin device 115. Alternatively, in some embodi-

ments, the configuration interface **300a** may be displayed directly by the access device **110**.

[0028] The configuration interface **300a** includes a user profile section **305** for selecting a user profile. For example, the administrator may select the user profile using a drop down menu. With a user profile is selected (such as User Profile A), the user devices assigned to the user profile are displayed in a user device section **310**. If no user devices are assigned to the user profile, the administrator may be given an option to assign user devices to the user profile, as described in reference to FIG. 2. The administrator may then select particular user devices assigned to the user profile to configure their access parameters. For example, three User Devices 1, 2, and 3 may be assigned to User Profile A. The administrator may then select User Devices 1 and 2 to configure the access parameters for those two user devices.

[0029] The access parameters may include a content usage parameter **315**, time and day usage parameters **320** and **325**, and/or a data usage parameter **330**. The content usage parameter **315** allow the administrator to select certain categories of content the selected user devices are permitted to access. For example, the administrator may select educational content and news content. Other categories of content may include sports content, gaming content (e.g. content associated with a video game console), video/TV content (e.g., streaming video websites, cable television, satellite television, etc.), and adult content. It should be noted that categories of content in addition to those listed may also be selected. Furthermore, the administrator may define custom categories of content for the content usage parameter **315**. After certain categories of content are selected for the content usage parameter **315**, the selected user devices may be restricted from accessing content that violates the content usage parameter **315**.

[0030] The time usage parameter **320** and day usage parameter **325** allow the administrator to select particular days and times that the selected user devices are permitted to access the selected categories of content. For example, the administrator may select weekdays for the day usage parameter **325**, and a time range between 6:00 pm and 10:00 pm for the time usage parameter **320**. The selected user devices may then be restricted from accessing all categories of content outside of the selected days and time range. During the selected days and time range, the selected user devices may only be permitted to access the categories of content selected for the content usage parameter **315**, as described above.

[0031] Alternatively or in addition to the time range shown in FIG. 3A, the time usage parameter **320** may include a time limit. The time limit may be set by the administrator to limit the total amount of time that the selected user devices are allowed to access the selected categories of content. For example, the administrator may set the time limit to two hours. Then the selected user devices may have a two hour limit for accessing the selected categories of content. The time limit may be set in combination with the day and time range. For example, the selected user devices may access the selected categories of content for a total of two hours between 6:00 pm and 10:00 pm on weekdays. The access device **110** may consolidate the amount of time each of the selected user devices spend accessing the selected categories of content. In this way, the time limit may represent the total amount of time that all of the selected user devices are allowed to access the content.

[0032] The data usage parameter **330** allows the administrator to limit the total amount of data that the selected user devices are permitted to use when accessing the selected content. For example, the administrator may set the data usage parameter **330** to 20 GB. After the selected user devices have consumed 20 GB of data, they may be restricted from accessing any additional content. The amount of data consumed may be consolidated across the selected user devices. In this way, the data usage parameter **330** may represent the total amount of data that all of the selected user devices are allowed to consume.

[0033] FIG. 3B is another example of a configuration interface **300b** for configuring access parameters for a user profile, in accordance with various aspects of the present disclosure. The configuration interface **300b** is similar to the configuration **300a** described in reference to FIG. 3A. However, in configuration interface **300b**, the third User Device 3 assigned to User Profile A is selected in the user device section **310**. In this way, different access parameters may be selected for User Device 3 as compared to User Devices 1 and 2, while they are all assigned to the same User Profile A.

[0034] As shown in FIG. 3B, the administrator may configure a different content usage parameter **315**, time and day usage parameters **320** and **325**, and data usage parameter **330** for the User Device 3. The content usage parameter **315** may be configured to allow sports content, gaming content, and video/TV content. The time usage parameters **320** may be configured to allow the User Device 3 to access the selected categories of content between 6:00 pm and 8:00 pm. The day usage parameter **325** may be configured to allow access to the selected content on weekdays. And the data usage parameter **330** may be configured to allow User Device 3 to use a maximum of 10 GB accessing the selected content **315**.

[0035] Time spent accessing the selected categories of content by User Device 3 may not apply to a time limit set for User Devices 1 and 2. Similarly, time spent accessing the selected categories of content by User Devices 1 and 2 may not apply to a time limit set for User Device 3. In this way, different user devices may be given different time limits. The same may also apply to the data usage parameter **330**. Data consumed by User Device 3 may not apply to the data usage parameter **330** of User Devices 1 and 2, and vice versa.

[0036] It should be noted that the the interfaces **300a** and **300b** shown in FIGS. 3A and 3B are examples. Other layouts and functionality may be included in the interfaces to allow an administrator to view or change the access parameters of the access device **110**.

[0037] FIG. 4 is a flow diagram **400** illustrating example operations of an access device **110**, in accordance with various aspects of the present disclosure. The operations of FIG. 4 are discussed in reference to the access device **110** described in reference to FIGS. 1-3. The operations of FIG. 4 are not all-inclusive, and may comprise additional operations described herein, and/or other operations not illustrated for the sake of brevity.

[0038] In one implementation, the access device **110** consolidates the data usage and time usage of multiple user devices associated with a user profile (operation **402**). The access device then identifies whether the consolidated data usage falls within a data usage range defined by the data usage parameter (operation **404**). If the user devices associated with the user profile have exceeded the data usage

range, then the access device **110** may restrict one or more of the user devices from accessing the communication network (operation **412**).

[0039] The access device **110** also identifies whether the consolidated time usage falls within a time usage limit and/or range defined by the time and day parameters (operation **406**). The time usage limit may be a total duration the user devices have spent accessing content. The time usage range may be a start and end time within which the user devices are allowed to access the content. If the user devices associated with the user profile have exceeded (and/or are outside of) their allowed time usage, then the access device **110** may restrict one or more of the user devices from accessing the communication network (operation **412**).

[0040] The access device **110** also identifies whether the content being accessed falls within the allowed categories of content defined by the content usage parameter (operation **408**). If the user devices associated with the user profile have tried to access content outside of the allowed categories, then the access device may restrict one or more of the user devices from accessing the communication network (operation **412**).

[0041] It should be noted that the operations **404**, **406**, and **408** may be carried out in any order.

[0042] If any of the operations **404**, **406**, or **408** cause access to the communication network to be restricted, then the administrator may be notified (operation **414**). The notification may provide information about why the access was restricted, and which devices and/or user profiles have been restricted.

[0043] If none of the operations **404**, **406**, or **408** cause access to the communication network to be restricted, then the user devices may continue to access the communication network (operation **410**), in accordance with the access parameters.

[0044] FIG. 5 illustrates an example of a display presenting a notification interface **500** to an administrator, in accordance with various aspects of the present disclosure. The notification interface **500** may include information **505** about why a user device and/or user profile has been restricted from accessing the communication network. For example, notification interface **500** may inform the administrator that “User A has exceeded the time limit for Gaming content.” The notification interface **500** may provide the administrator with options **510** and **515** to either allow the user profile to continue accessing the communication network (option **510**) or to confirm that access should be restricted (option **515**). For example, the administrator may be provided with an option to “Extend Gaming time” and an option to “Restrict Gaming content.”

[0045] The notification interface **500** may also present other information to the administrator. For example, the administrator may view the current status of user devices connected to the access device **110**. The status may include the current content being accessed, the total time spent accessing the content, and the current amount of data that has been consumed. The administrator may also view or change the access parameters, as described in reference to FIGS. 3A and 3B.

[0046] In addition or alternatively to the displayed notification interface **500**, the access device may provide the administrator with an audio notification and/or a tactile notification. The audio notification may include an alarm or a spoken message associated with the user device and/or

user profile being restricted from accessing the communication network. The tactile notification may include a vibration or pattern of vibrations associated with the user device and/or user profile being restricted from accessing the communication network.

[0047] FIG. 6 illustrates an example of an access device **110**, in accordance with various aspects of the present disclosure. The access device **110** may be an example of the access devices described in reference to FIGS. 1-5. The access device **110** includes a local area network (LAN) communication module **605** and a wide area network (WAN) communication module **610**. The LAN communication module **605** connects to the user devices **105** and allows the user devices to communicate with one another. The WAN communication module **610** connects to the external communication network **120**.

[0048] The access device **110** allows the user devices to access the external communication network **120** by routing communications from the LAN communication module **605** to the WAN communication module **610**. Some of the communications from the user devices **105** may be restricted by filters **615** based on how the access device is configured, as described in reference to FIGS. 3A and 3B. For example, certain user devices **105** may only be allowed to access the communication network **120** at certain times of day, so the filters may block communications from those user devices when they try to communicate outside of the allowed time range.

[0049] The filters **615** and communications between the LAN communication module **605** and WAN communication module **610** may be controlled or configured by a control logic **620**. The control logic **620** may utilize access parameters stored in a storage unit **625** to configure the filters **615**. The access parameters may include a data usage parameter, time and day usage parameters, and a content usage parameter. The storage unit **625** may also store user profile information. The user profile information may link particular user devices connected to the access device **110** with certain users or administrators. Each user profile may be associated with a different set of access parameters.

[0050] FIG. 7 is a flow diagram illustrating an example of a process **700** for restricting access to a communication network, in accordance with various aspects of the present disclosure. The process may be performed by an access device **110**, as described in reference to FIGS. 1-6.

[0051] At **702**, a plurality of user devices are assigned to a user profile. The user devices may correspond to devices that are connected to the access device, and the user profile may correspond to a particular user that owns or utilizes the assigned user devices. An administrator may assign the user devices to a user profile by, for example, dragging and dropping each user device into a user profile on an interface provided by the access device.

[0052] At **704**, at least one access parameter is designated for the user profile. The access parameter may include a data usage parameter, a time usage parameter, a day usage parameter, and a content usage parameter. The content usage parameter may define particular categories of content that the user devices assigned to the user profile are allowed to access. The time usage parameter may define a time range and/or a time limit for accessing the categories of content and/or a communication network. The day usage parameter may define particular days of the week for accessing the categories of content and/or the communication network.

The data usage parameter may define a data usage limit for the user profile to access the categories of content and/or the communication network.

[0053] At **706**, the data usage, time usage, and content usage of each of the plurality of user devices are monitored by the access device.

[0054] At **708**, the data usage and/or time usage of the plurality of user devices may optionally be consolidated by the access device. The access device may consolidate the data usage by summing the total data used by the plurality of user devices while accessing particular content and/or the communication network. The access device may consolidate the time usage by summing the total time the plurality of user devices have spent accessing particular content and/or the communication network.

[0055] At **710**, the access device determines that one or more of the data usage, time usage, and/or content usage violate the at least one access parameter designated for the user profile. In some examples, the data usage and/or time usage may be the consolidated across all user devices assigned to a user profile. For example, the data usage may violate a data usage parameter by exceeding a data usage limit. The time usage may violate a time usage parameter by exceeding a time usage limit. The content usage may violate a content usage parameter by attempting to access content that is outside of certain categories of content.

[0056] At **712**, the access device restricts at least one of the plurality of user devices from accessing a communication network. Alternatively, the user device may be restricted from accessing particular content on the communication network. For example, the user may be restricted from accessing gaming content if one or more access parameters are violated.

[0057] In some embodiments, the access device may also notify an administrator device when at least one of the plurality of user devices is restricted from accessing the communication network and/or particular content. The notification may include a visual notification, an audio notification, and/or a tactile notification. The notification may indicate the access parameter that was violated. The access device may also receive an instruction from the administrator device to allow the restricted user device to continue accessing the communication network.

[0058] The process **700** may include additional acts, omit some acts, and/or may perform the acts in a different order than set out in the FIG. **7**.

[0059] Although specific embodiments were described herein, the scope of the invention is not limited to those specific embodiments. The scope of the invention is defined by the following claims and any equivalents therein.

What is claimed is:

1. A method, comprising:

- assigning a plurality of user devices to a user profile;
- designating at least one access parameter for the user profile;
- monitoring data usage, time usage, and content usage of each of the plurality of user devices;
- determining that one or more of the data usage, time usage, or content usage violate the at least one access parameter of the user profile; and
- restricting at least one of the plurality of user devices from accessing a communication network.

2. The method of claim **1**, wherein the at least one access parameter comprises one or more of a data usage limit, a time usage limit, a time usage range, and content categories.

3. The method of claim **1**, further comprising:
notifying an administrator device when at least one of the plurality of user devices is restricted from accessing the communication network.

4. The method of claim **3**, wherein the notification comprises an indication of the at least one access parameter that was violated.

5. The method of claim **3**, further comprising:
receiving an instruction from the administrator device to allow the at least one of the plurality of user devices to continue accessing the communication network.

6. The method of claim **1**, further comprising:
consolidating the data usage and time usage of the plurality of user devices.

7. The method of claim **6**, wherein consolidating the data usage comprises summing the total data used by the plurality of user devices.

8. The method of claim **6**, wherein consolidating the time usage comprises summing the total time the plurality of user devices have been used.

9. The method of claim **1**, wherein the content usage comprises one or more categories of content accessed by the plurality of user devices.

10. The method of claim **1**, further comprising:
designating two or more access parameters for the user profile; and
determining that two or more of the data usage, time usage, or content usage violate two or more of the access parameters.

11. An access device, comprising:

- a local area network (LAN) communication module in communication with a plurality of user devices;
- a wide area network (WAN) communication module in communication with an external network;

at least one filter to selectively restrict communications between the plurality of user devices and the external network;

a storage unit to store at least one user profile associated with the plurality of user devices and at least one access parameter for the at least one user profile; and

a control logic to configure the at least one filter based on the user profile and the at least one access parameter, wherein the control logic monitors data usage, time usage, and content usage of each of the plurality of user devices, and

wherein the at least one filter restricts at least one of the plurality of user devices from accessing the external network based on one or more of the data usage, time usage, or content usage violating the at least one access parameter.

12. The access device of claim **11**, wherein the at least one access parameter comprises one or more of a data usage limit, a time usage limit, a time usage range, and content categories.

13. The access device of claim **11**, wherein the control logic is configured to notify an administrator device when at least one of the plurality of user devices is restricted from accessing the communication network.

14. The access device of claim **13**, wherein the notification comprises an indication of the at least one access parameter that was violated.

15. The access device of claim **13**, wherein the control logic is configured to receive an instruction from the administrator device to allow the at least one of the plurality of user devices to continue accessing the communication network.

16. The access device of claim **11**, wherein the control logic is further configured to consolidate the data usage and time usage of the plurality of user devices.

17. The access device of claim **16**, wherein consolidating the data usage comprises summing the total data used by the plurality of user devices.

18. The access device of claim **16**, wherein consolidating the time usage comprises summing the total time the plurality of user devices have been used.

19. The access device of claim **11**, wherein the content usage comprises one or more categories of content accessed by the plurality of user devices.

20. The access device of claim **11**, wherein the storage unit stores two or more access parameters for the user profile, and wherein the at least one filter restricts at least one of the plurality of user devices from accessing the external network based on two or more of the 4 data usage, time usage, or content usage violating two or more of the access parameters.

* * * * *