



US 20200026003A1

(19) **United States**

(12) **Patent Application Publication**
Coolbaugh et al.

(10) **Pub. No.: US 2020/0026003 A1**

(43) **Pub. Date: Jan. 23, 2020**

(54) **INTEGRATED PHOTONICS INCLUDING GERMANIUM**

(71) Applicant: **The Research Foundation for the State University of New York, Albany, NY (US)**

(72) Inventors: **Douglas Coolbaugh, Highland, NY (US); Thomas Adam, Slingerlands, NY (US); Gerald L. Leake, Delmar, NY (US)**

(21) Appl. No.: **16/396,128**

(22) Filed: **Apr. 26, 2019**

Related U.S. Application Data

(60) Continuation of application No. 15/864,651, filed on Jan. 8, 2018, now Pat. No. 10,295,745, which is a division of application No. 14/987,693, filed on Jan. 4, 2016, now Pat. No. 9,864,138.

(60) Provisional application No. 62/099,848, filed on Jan. 5, 2015.

Publication Classification

(51) **Int. Cl.**
G02B 6/13 (2006.01)
H01L 27/146 (2006.01)
H01L 31/028 (2006.01)

H01L 21/02 (2006.01)
H01L 21/203 (2006.01)
H01L 21/205 (2006.01)
H01L 31/0232 (2006.01)
H01L 31/105 (2006.01)
H01L 31/0224 (2006.01)
H01L 31/18 (2006.01)
G02B 6/12 (2006.01)
(52) **U.S. Cl.**
CPC **G02B 6/13** (2013.01); **G02B 6/43** (2013.01); **H01L 31/028** (2013.01); **H01L 21/02532** (2013.01); **H01L 21/0245** (2013.01); **H01L 21/02381** (2013.01); **H01L 21/2033** (2013.01); **H01L 21/2053** (2013.01); **H01L 31/02327** (2013.01); **H01L 31/105** (2013.01); **H01L 31/022408** (2013.01); **H01L 31/1808** (2013.01); **H01L 21/02505** (2013.01); **H01L 21/02573** (2013.01); **H01L 21/0262** (2013.01); **H01L 21/02639** (2013.01); **G02B 6/12002** (2013.01); **H01L 31/0232** (2013.01); **H01L 27/14629** (2013.01); **Y02E 10/52** (2013.01); **Y02E 10/547** (2013.01); **H01L 27/14625** (2013.01)

(57) **ABSTRACT**

A photonic structure can include in one aspect one or more waveguides formed by patterning of waveguiding material adapted to propagate light energy. Such waveguiding material may include one or more of silicon (single-, poly-, or non-crystalline) and silicon nitride.

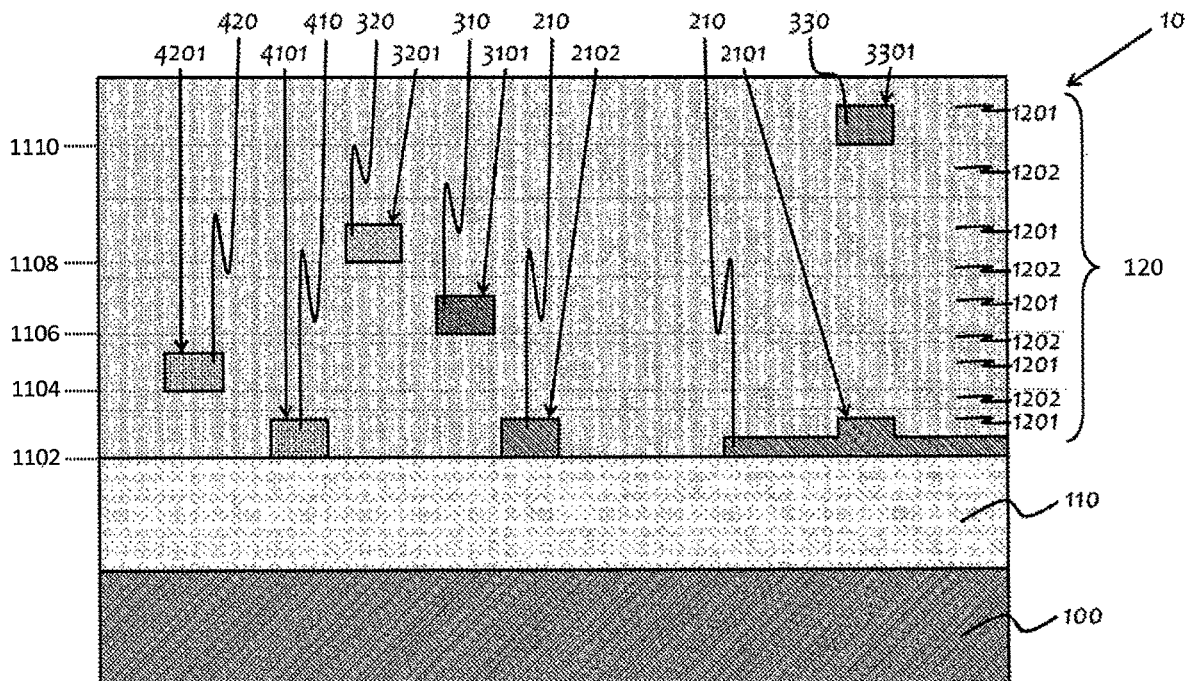

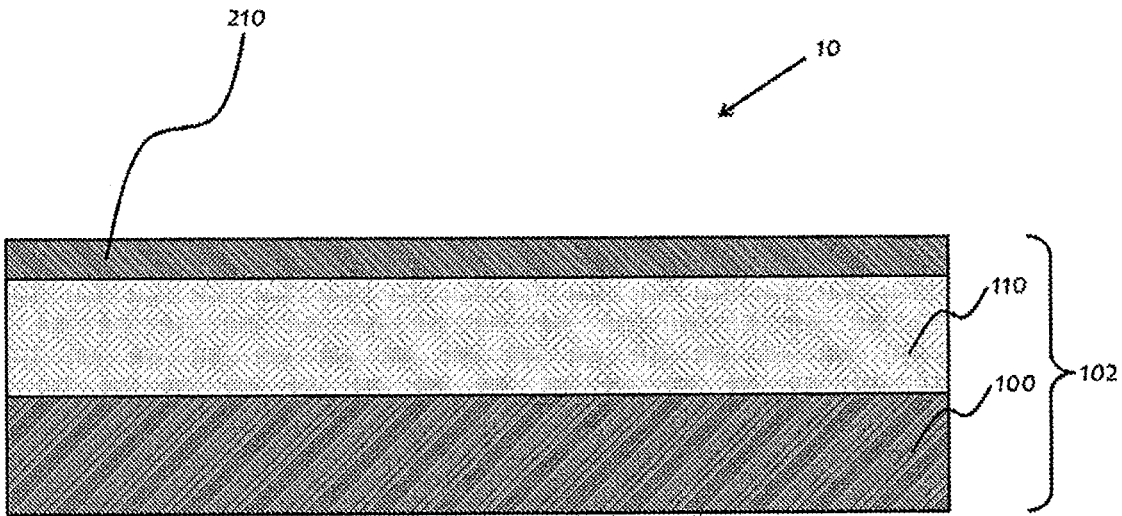

FIG. 1

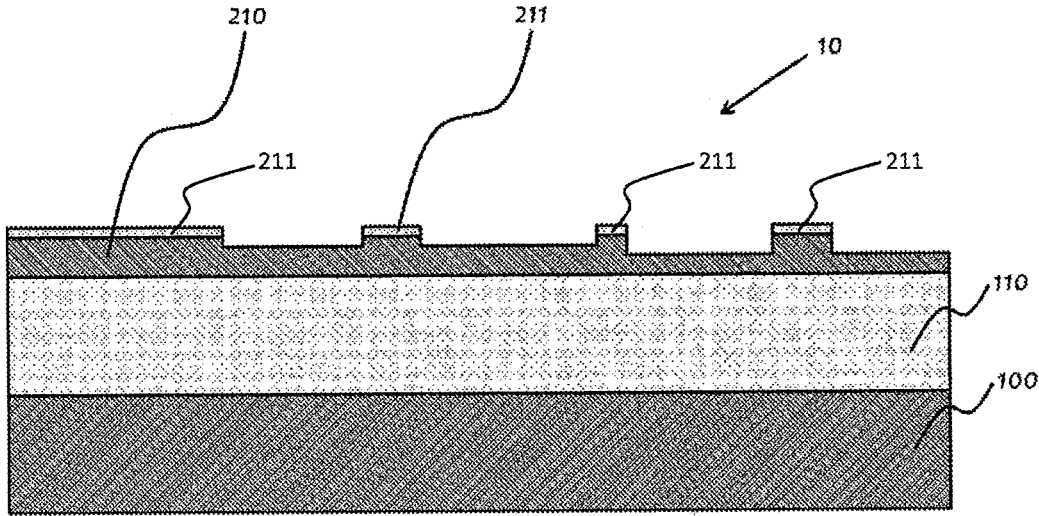

FIG. 2

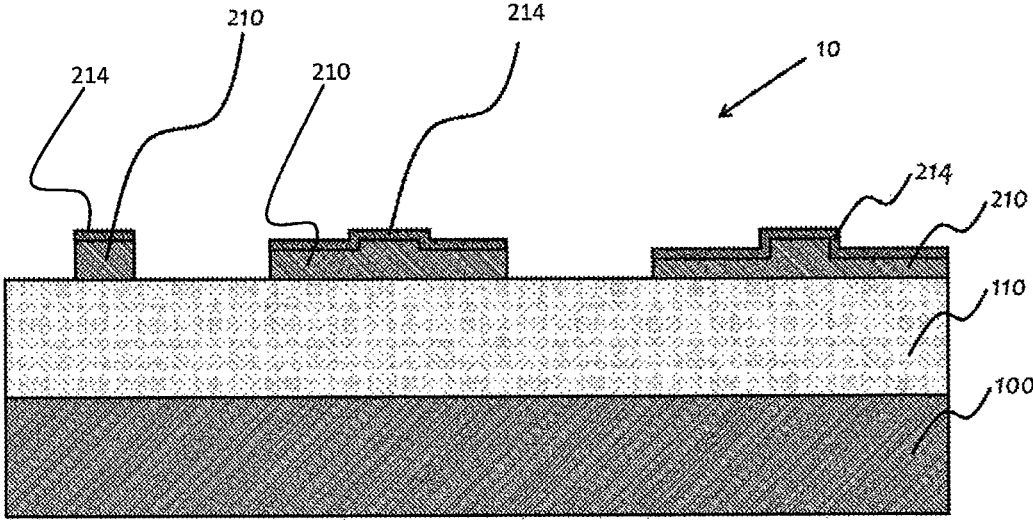

FIG. 3

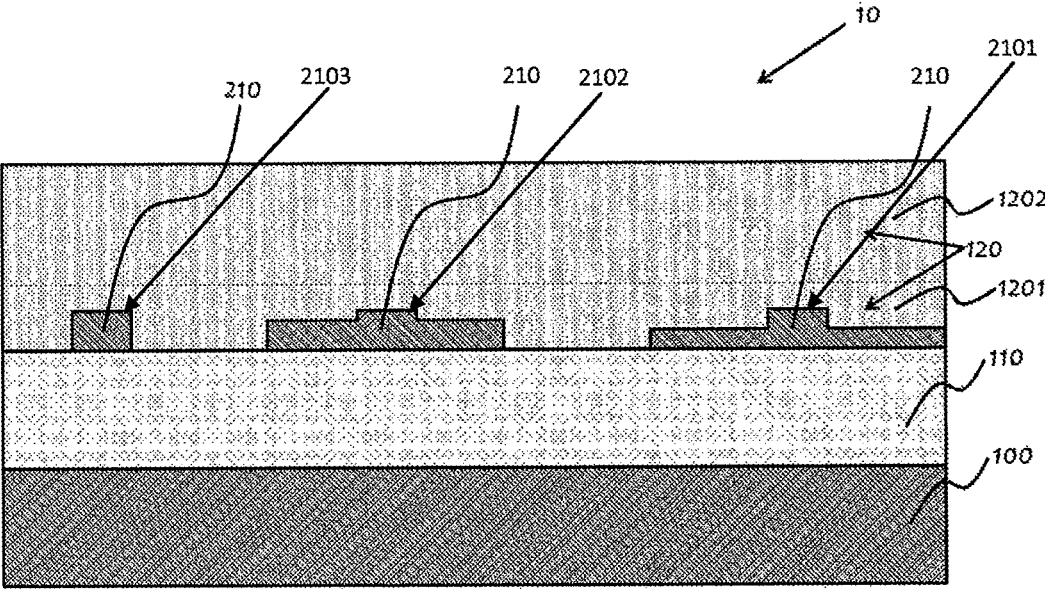

FIG. 4

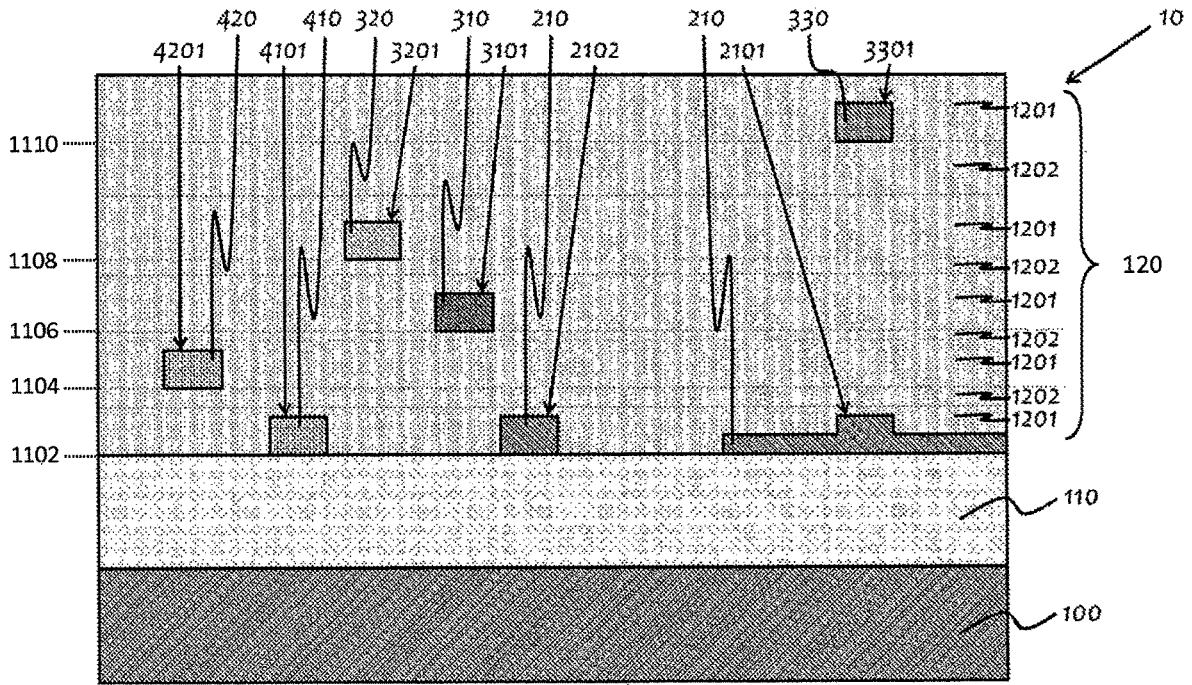

FIG. 5

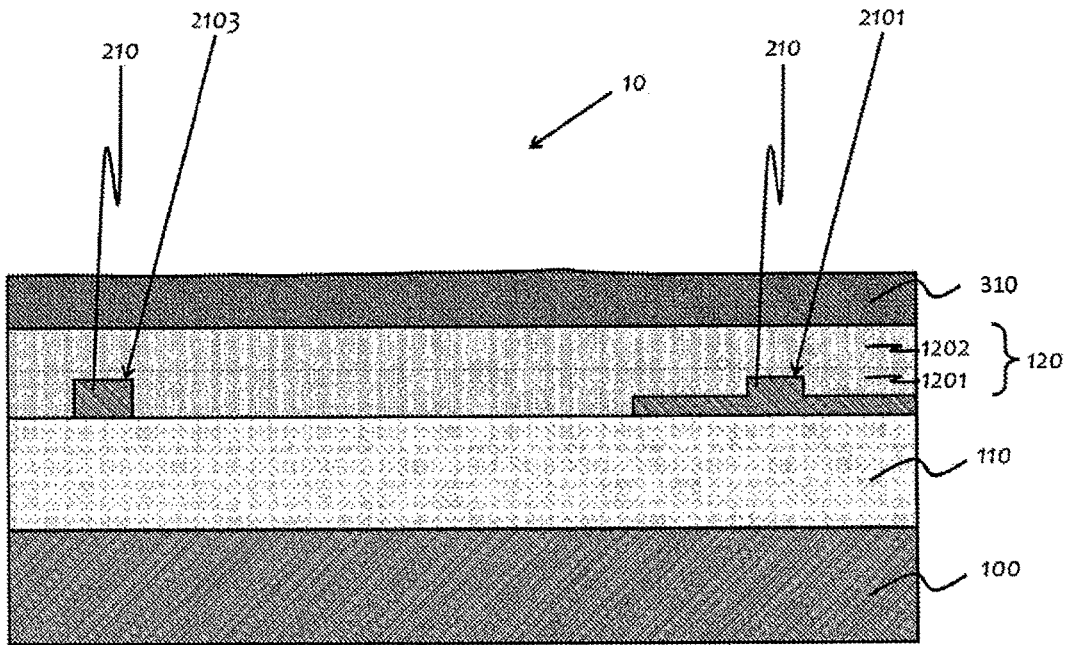

FIG. 6

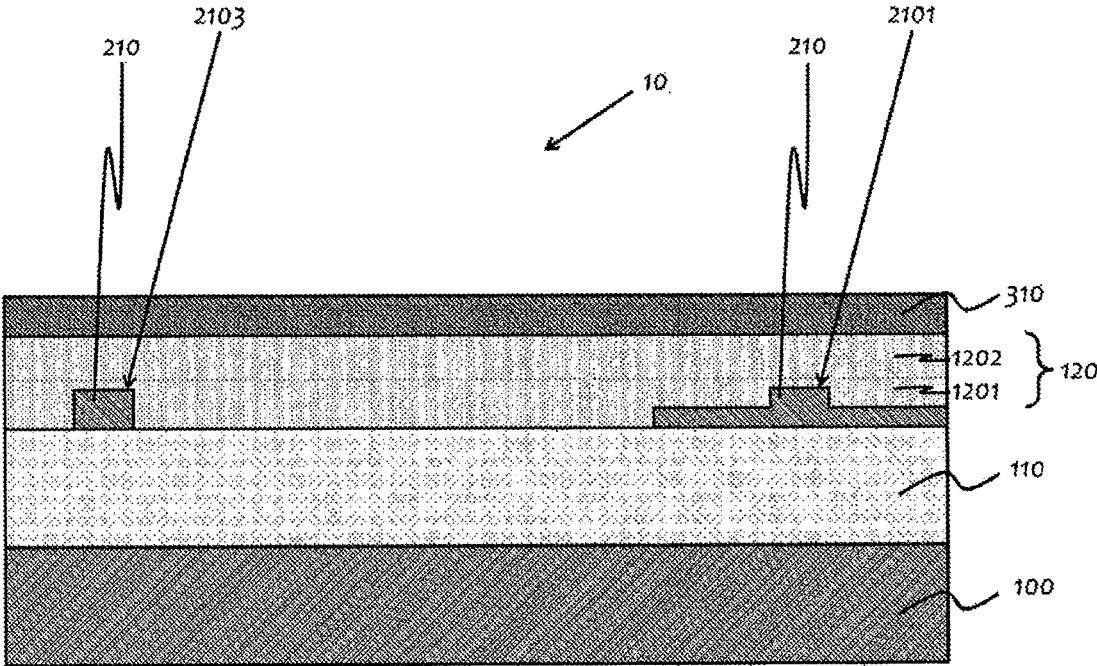

FIG. 7

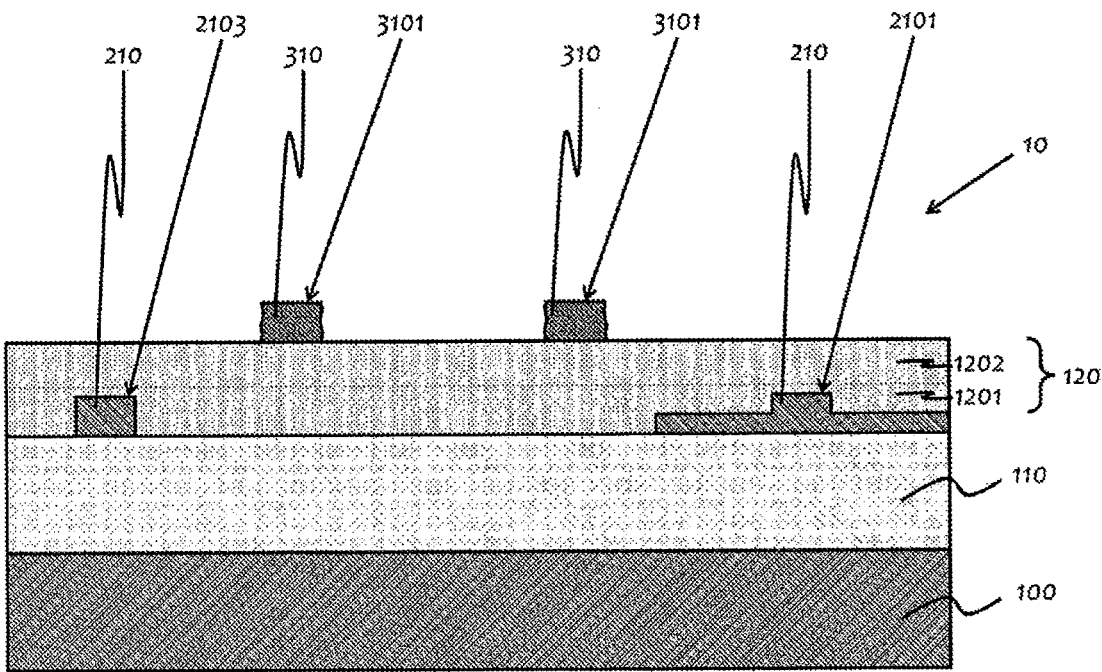

FIG. 8

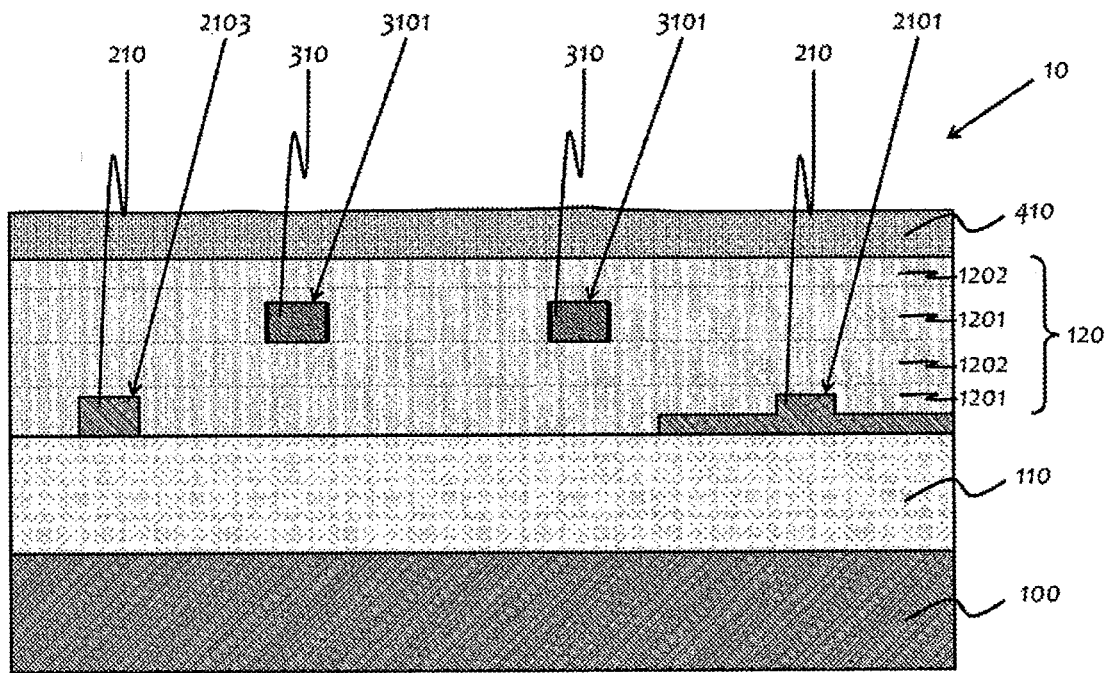

FIG. 9

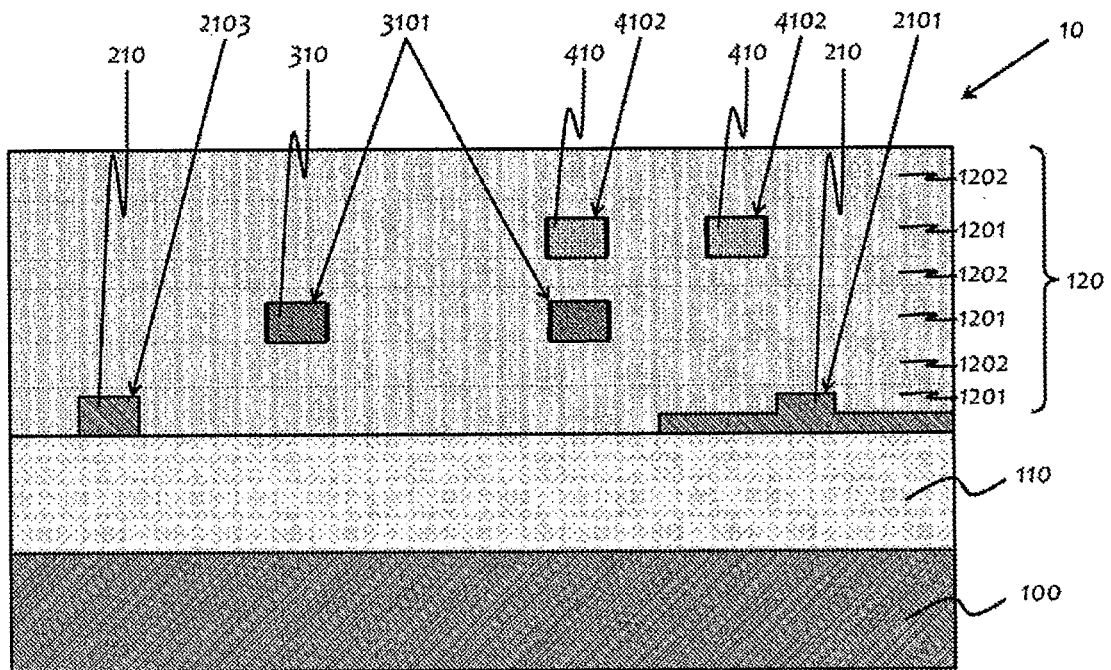

FIG. 10

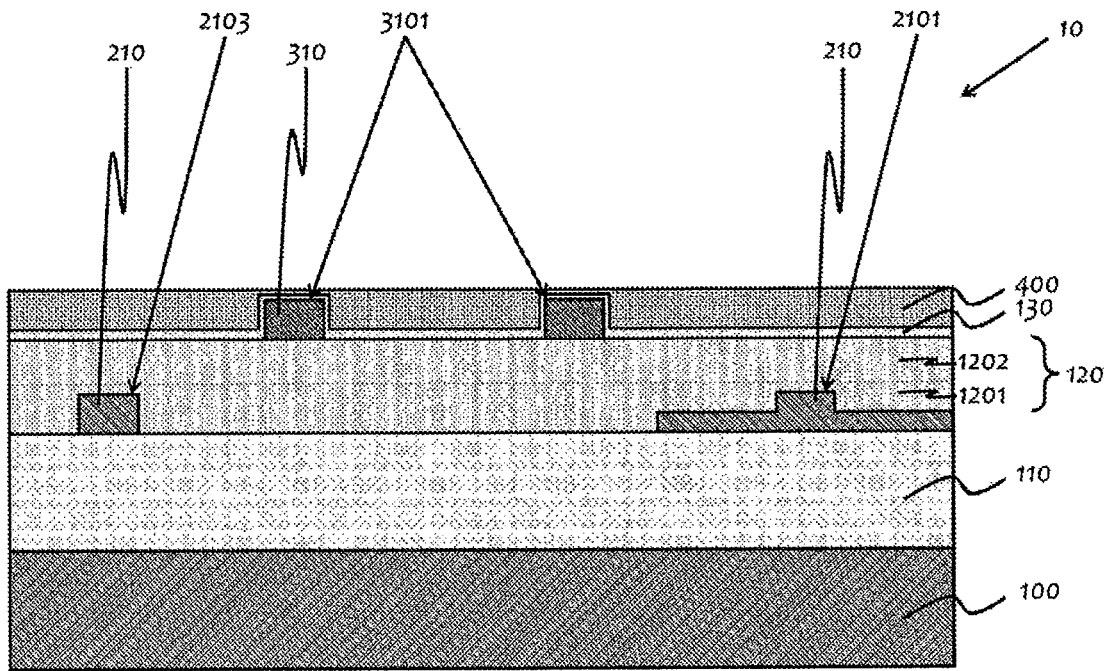

FIG. 11

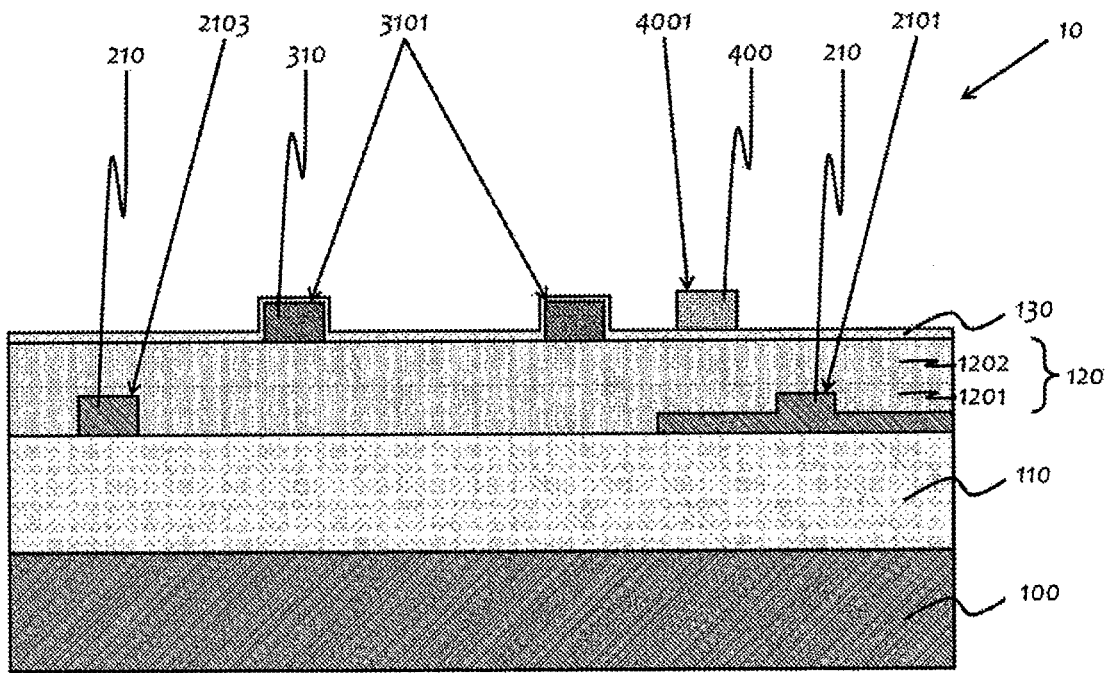

FIG. 12

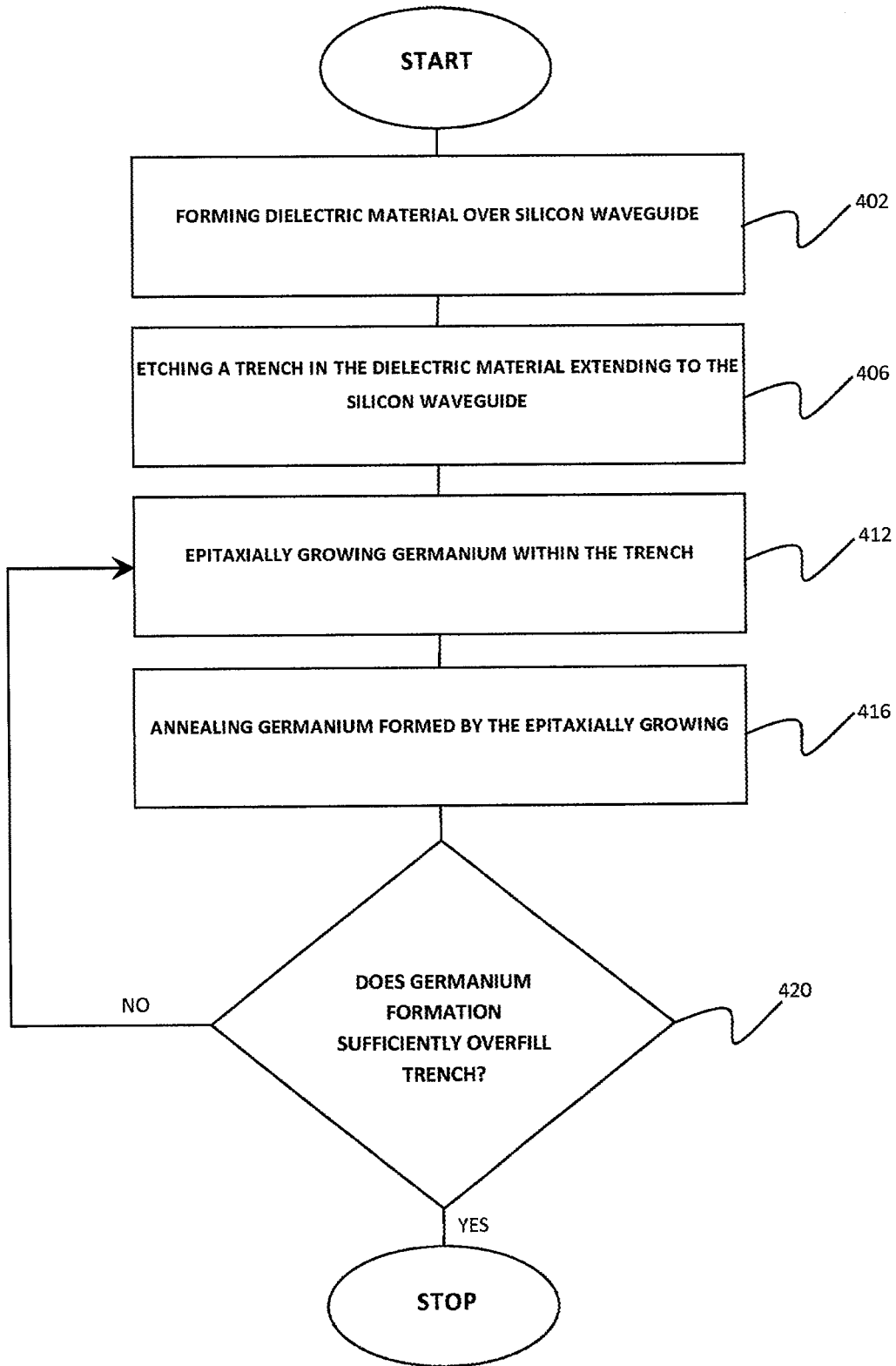

FIG. 13

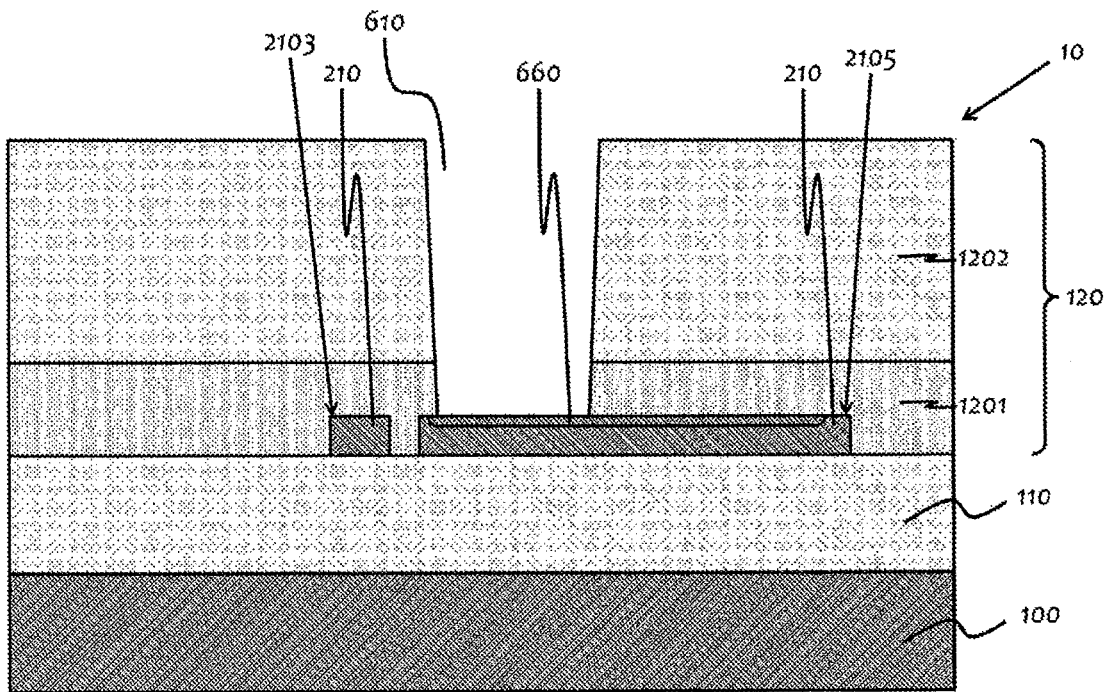

FIG. 14

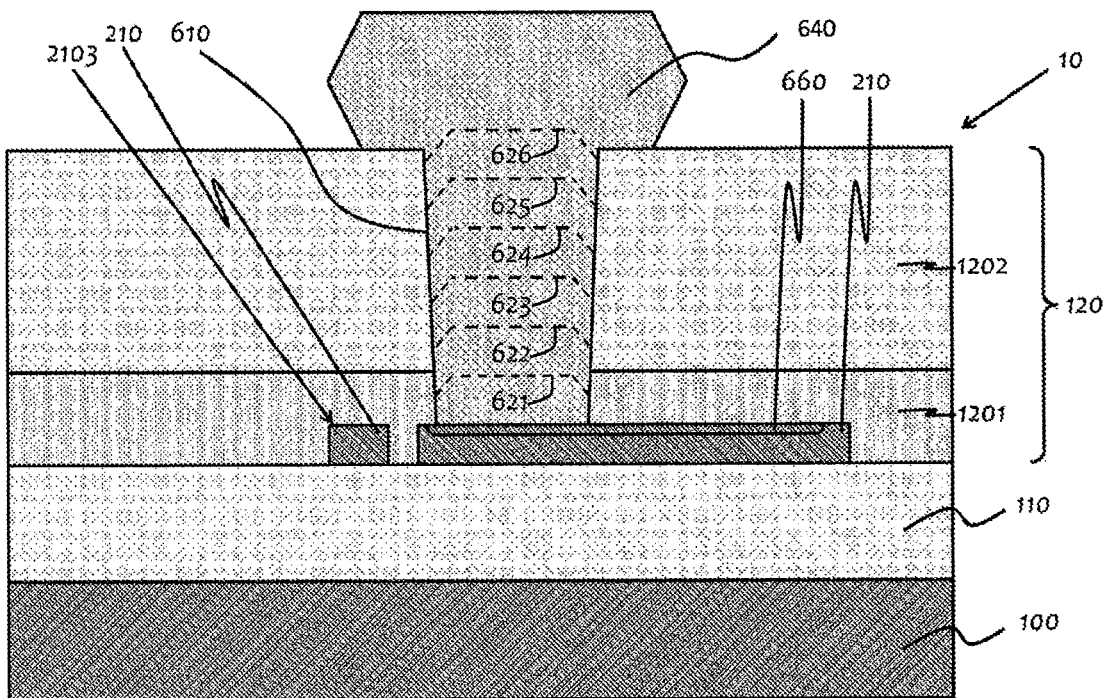

FIG. 15

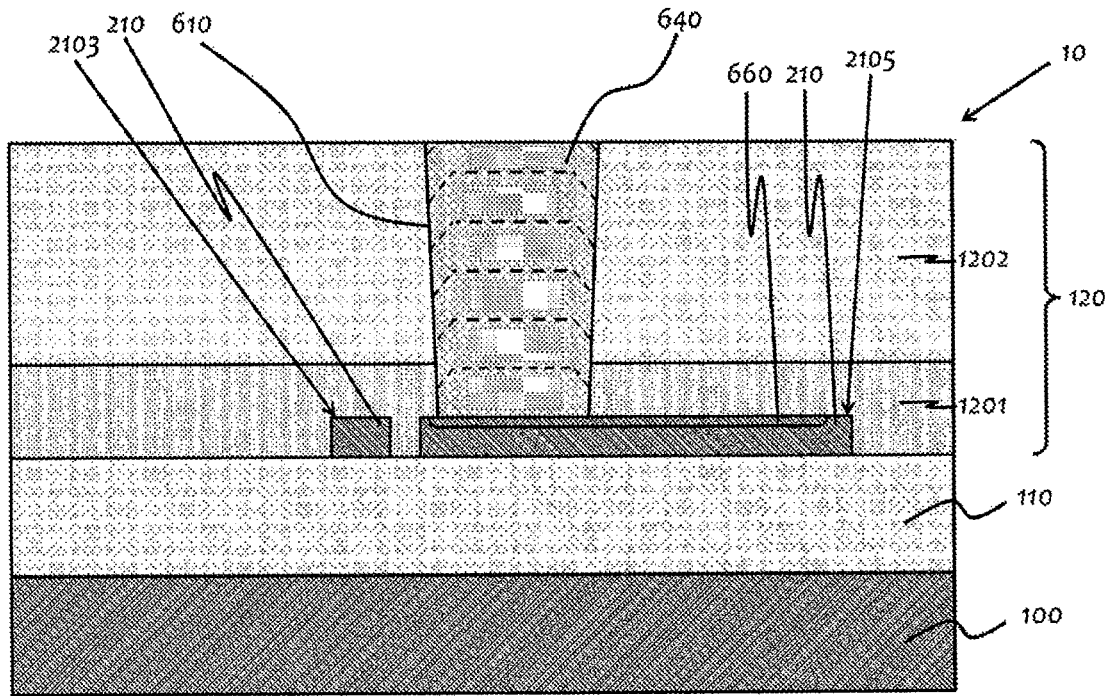

FIG. 16

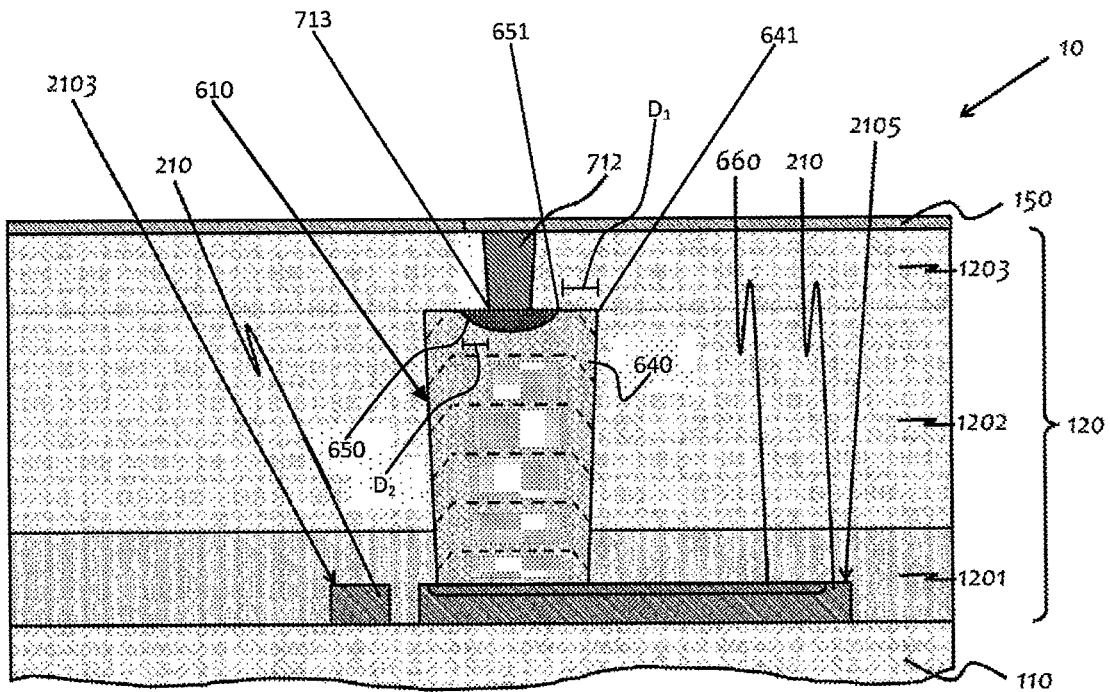

FIG. 17

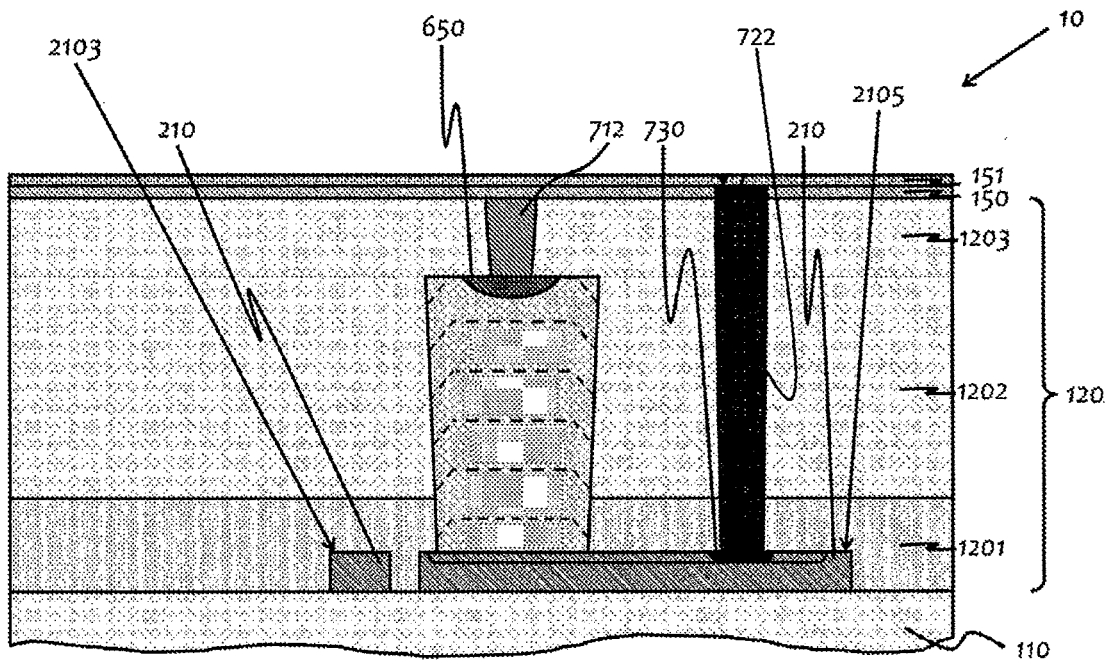

FIG. 18

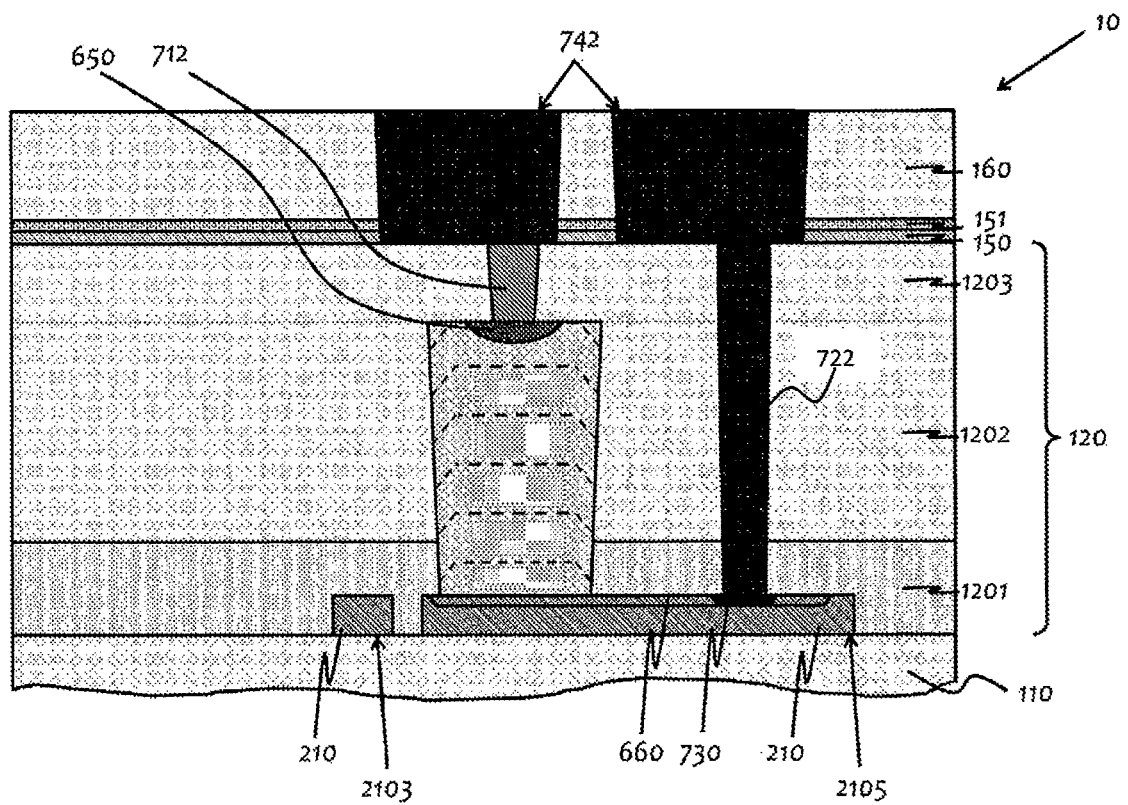

FIG. 19

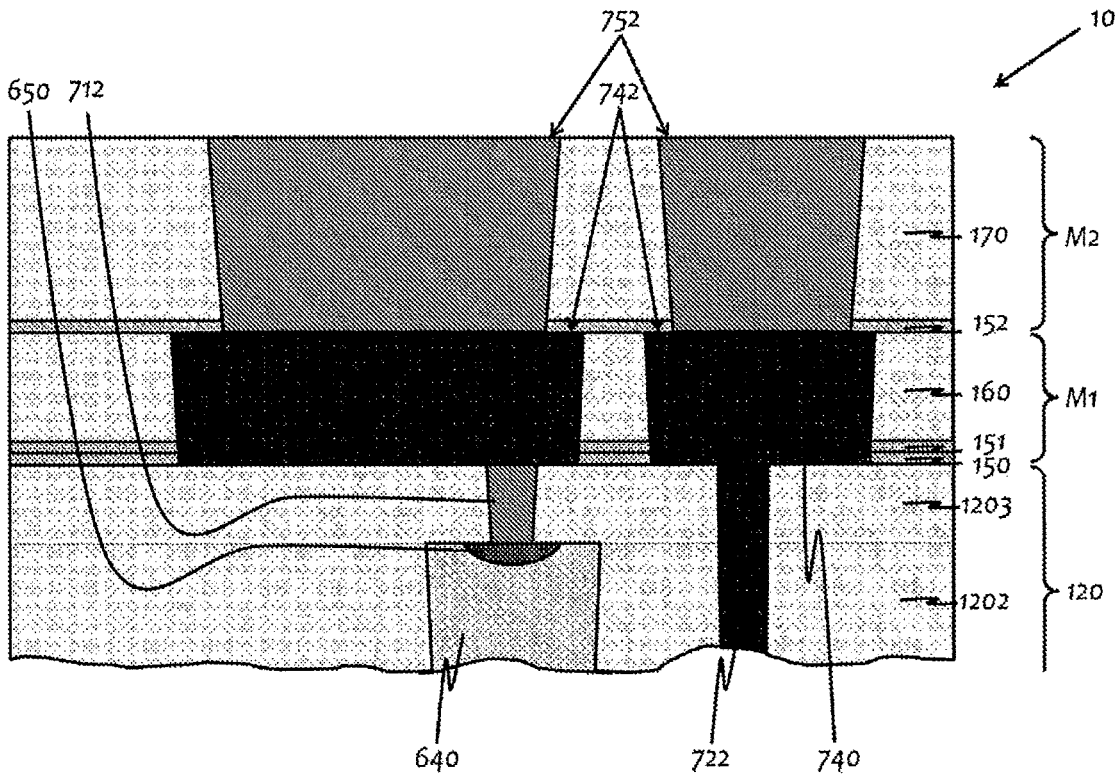

FIG. 20

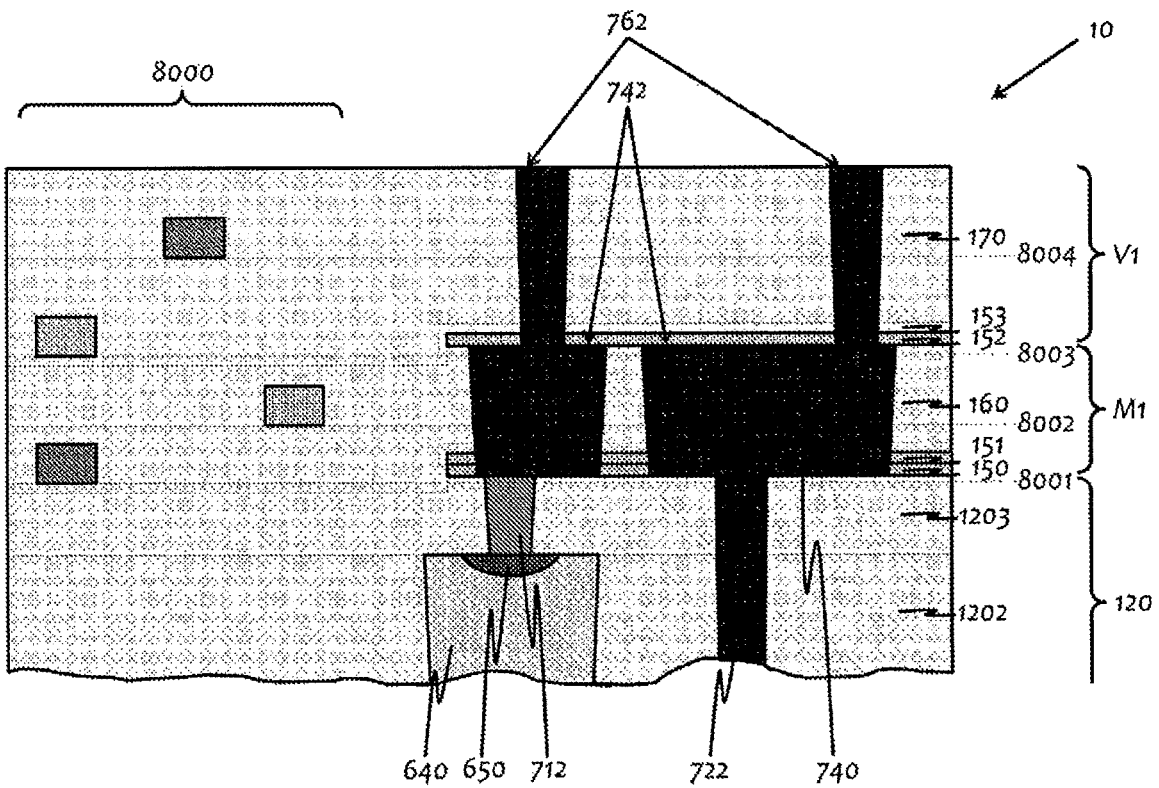

FIG. 21

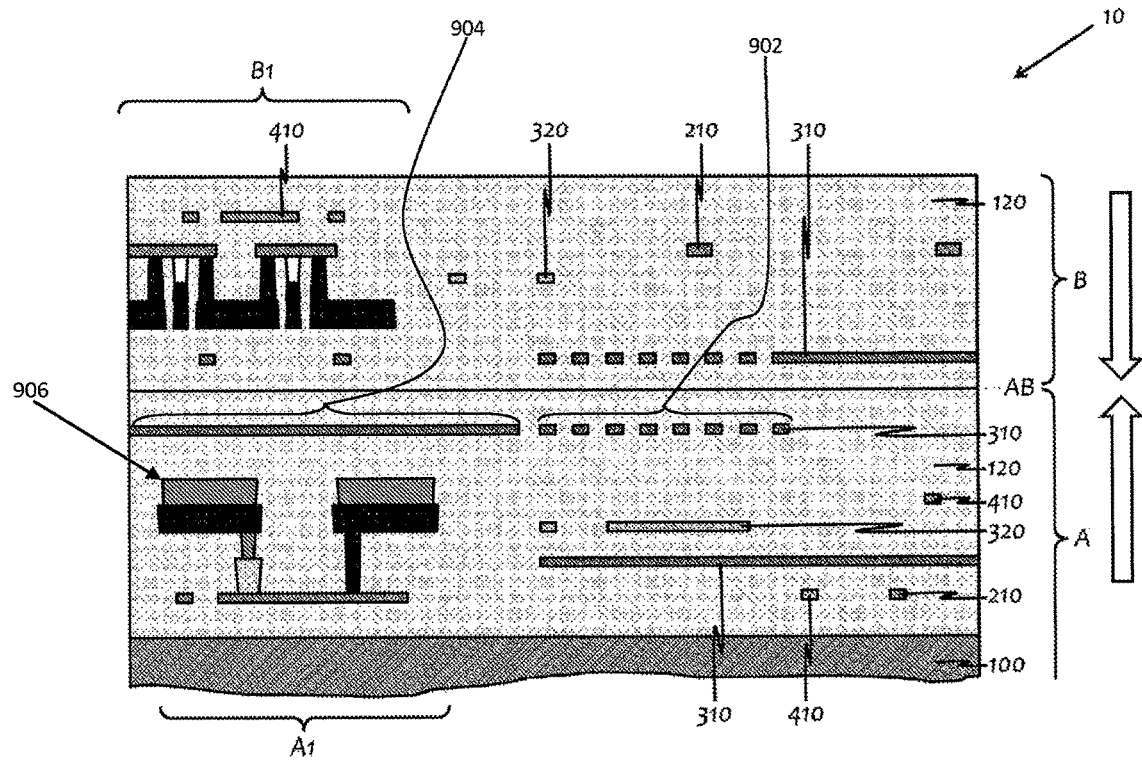

FIG. 22

**INTEGRATED PHOTONICS INCLUDING
GERMANIUM****CROSS REFERENCE TO RELATED
APPLICATIONS**

[0001] This application is a continuation of U.S. application Ser. No. 15/864,651, filed Jan. 8, 2018, titled “Integrated Photonics Including Germanium”, which is incorporated by referenced herein in its entirety, which is a divisional of U.S. patent application Ser. No. 14/987,693, filed Jan. 4, 2016, entitled “Integrated Photonics Including Germanium,” which is incorporated herein by reference in its entirety, which claims the benefit of priority of U.S. Provisional Application No. 62/099,848 filed on Jan. 5, 2015 entitled “Integrated Photonics Process on SOI Wafer,” which is incorporated herein by reference in its entirety.

GOVERNMENT RIGHTS STATEMENT

[0002] This invention was made with government support under Defense Advanced Research Projects Agency (DARPA) of the United States, under grant contract number HR0011-12-2-0007. The government may have certain rights in the invention.

FIELD

[0003] The present disclosure relates to photonics generally and specifically to photonic structures and processes for fabrication.

BACKGROUND

[0004] Commercially available photonic integrated circuits are fabricated on wafers, such as bulk silicon or silicon-on-insulator wafers.

[0005] In one aspect photonics integrated circuits can include waveguides for transmission of optical signals between different areas of a photonic integrated circuit chip as well as on and off the chip. Commercially available waveguides are of rectangular or ridge geometry and are fabricated in silicon (single or polycrystalline) or silicon nitride.

[0006] Commercially available photonics integrated circuits can include photodetectors and other optical components. Photonic integrated circuits rely on the emission, modulation and the detection of light in the communication band (about 1.3 μm to about 1.55 μm). A bandgap absorption edge in germanium is near 1.58 μm . Germanium has been observed to provide sufficient photo-response for optoelectronic applications using 1.3 μm and 1.55 μm carrier wavelengths.

BRIEF DESCRIPTION

[0007] The shortcomings of the prior art are overcome, and additional advantages are provided, through the provision, in one aspect, of a photonic structure.

[0008] A photonic structure can include in one aspect one or more waveguides formed by patterning of waveguiding material adapted to propagate light energy. Such waveguiding material may include one or more of silicon (single-, poly-, or non-crystalline) or silicon nitride.

[0009] Additional features and advantages are realized through the techniques of the present disclosure.

**BRIEF DESCRIPTION OF THE SEVERAL
VIEWS OF THE DRAWINGS**

[0010] One or more aspects of the present disclosure are particularly pointed out and distinctly claimed as examples in the claims at the conclusion of the specification. The foregoing and other objects, features, and advantages of the disclosure are apparent from the following detailed description taken in conjunction with the accompanying drawings in which:

[0011] FIG. 1 is a cross sectional view of a wafer pre-constructed for the fabrication of photonic structures;

[0012] FIG. 2 is a cross sectional view of the photonic structure in an intermediary stage of fabrication after patterning of multiple exemplary ridge-type waveguides using a first set of hardmask materials;

[0013] FIG. 3 is a cross sectional view of a photonic structure in an intermediary stage of fabrication after formation of multiple exemplary geometries of waveguides (rectangular and ridge) using a second set of hardmask materials;

[0014] FIG. 4 is a cross sectional view of a photonic structure in an intermediary stage of fabrication after removal of hardmask/softmask materials and deposition, planarization, and encapsulation using low-temperature oxide;

[0015] FIG. 5 is a cross sectional view of an exemplary photonic structure having multiple-geometry waveguides formed at multiple elevations;

[0016] FIG. 6 is a cross sectional view of a photonic structure after deposition of a second waveguiding layer over a first waveguiding layer;

[0017] FIG. 7 is a cross sectional view of a photonic structure in an intermediary stage of fabrication after being subject to planarization and surface smoothing;

[0018] FIG. 8 is a cross sectional view of a photonic structure in an intermediary stage of fabrication after waveguide patterning and sidewall roughness treatment;

[0019] FIG. 9 is a cross sectional view of a photonic structure in an intermediary stage of fabrication after deposition of a third waveguide over a second waveguiding layer;

[0020] FIG. 10 is a cross sectional view of a photonic structure in an intermediary stage of fabrication after waveguiding layer planarization and smoothing, patterning of waveguides from a layer formed of a second waveguiding material, sidewall roughness treatment, and deposition, planarization, and encapsulation using low-temperature oxide;

[0021] FIG. 11 is a cross sectional view of a photonic structure in an intermediary stage of fabrication after formation and planarization of a layer of waveguiding material (for example: amorphous or poly-crystalline silicon);

[0022] FIG. 12 is a cross sectional view of a photonic structure in an intermediary stage of fabrication after patterning and sidewall roughness treatment of a layer formed of waveguiding material;

[0023] FIG. 13 is a flow diagram illustrating a method for fabrication of a photonic structure for use in photodetectors;

[0024] FIG. 14 is a photonic structure in an intermediary stage of fabrication after formation of a detector trench in planarized oxide over waveguiding features in crystalline silicon;

[0025] FIG. 15 is a photonic structure in an intermediary stage of fabrication after cycles of selective epitaxial growth and in-situ annealing to form a low defect-count single-crystalline germanium formation that overfills a trench;

[0026] FIG. 16 is a photonic structure in an intermediary stage of fabrication after planarizing the overgrown portion of the germanium formation;

[0027] FIG. 17 is a photonic structure in an intermediary stage of fabrication after formation of conductive top contact and capping with a layer formed of a first hardmask material;

[0028] FIG. 18 is a photonic structure in an intermediary stage of fabrication after formation of a conductive bottom contact and capping with a layer formed of a second hardmask material;

[0029] FIG. 19 is a photonic structure in an intermediary stage of fabrication after formation of a patterned conductive first wiring level;

[0030] FIG. 20 is a photonic structure in an intermediary stage of fabrication after formation of a patterned conductive second wiring level;

[0031] FIG. 21 is a photonic structure in an intermediate stage of fabrication having a waveguiding layer at a common elevation with a wiring level;

[0032] FIG. 22 is a photonic structure in an intermediate stage of fabrication having a photonic component embedded in an assembly created by bonding.

DETAILED DESCRIPTION

[0033] Aspects of the present disclosure and certain features, advantages, and details thereof, are explained more fully below with reference to the non-limiting examples illustrated in the accompanying drawings. Descriptions of well-known materials, fabrication tools, processing techniques, etc., are omitted so as not to unnecessarily obscure the disclosure in detail. It should be understood, however, that the detailed description and the specific examples, while indicating aspects of the disclosure, are given by way of illustration only, and not by way of limitation. Various substitutions, modifications, additions, and/or arrangements, within the spirit and/or scope of the underlying inventive concepts will be apparent to those skilled in the art from this disclosure.

[0034] A photonic structure can include in one aspect one or more waveguides formed by patterning of waveguiding material adapted to propagate light energy. Such waveguiding material may include one or more of silicon (single-, poly-, or non-crystalline) and silicon nitride. Additional dielectric material over the one or more waveguides may serve as cladding and separation material.

[0035] In one embodiment, one or more photosensitive detectors fabricated from embedded epitaxial germanium may be included in the photonic structure to allow high-speed and efficient detection of optical signals.

[0036] In one embodiment, a pre-constructed wafer can be used for the fabrication of the disclosed photonic structure.

[0037] In one embodiment, there is set forth herein a photonic structure fabricated using one or more layers formed of hardmask material. The one or more layers of hardmask material allow for in-situ and ex-situ cleaning of residue generated by dry-etching equipment, and concurrently preventing the consumption of material from a waveguiding layer during fabrication.

[0038] In one embodiment, a photonic structure can include waveguides of one or more geometries (for example, rectangular or ridge-type) and one or more different sizes-patterned using a single layer of waveguiding material or distributed over multiple levels of similar or dissimilar

waveguiding material layers. Waveguiding layers herein can be regarded as photonic layers.

[0039] In one embodiment, the fabrication processes can include forming a cladding layer using non-conformal materials over one or more formed waveguide employing high-aspect-ratio processing (HARP). Non-conformality may be achieved using plasma enhancements during the deposition process, with conditions tuned to enhance deposition rates on horizontal surfaces while suppressing deposition rates on vertical surfaces (at step edges). Thus, voids and other defects resulting from pinch off of a cladding layer can be avoided, and detrimental effects of the same on optical properties can be minimized.

[0040] In one embodiment, a photonic structure can be fabricated to include one or more nitride waveguides using high-quality low-thermal-budget plasma-enhanced chemical vapor deposition (PECVD).

[0041] In one embodiment, a photonic structure can be fabricated to include one or more poly-crystalline or amorphous waveguides using chemical vapor deposition from various precursors (for example, silane for poly-crystalline, and disilane for amorphous).

[0042] In one embodiment, a photonic structure can include waveguides patterned from one or more waveguiding layers of dissimilar waveguiding material. The waveguiding materials of the different layers may also include a combination of common and dissimilar materials. A dielectric layer can separate the different waveguiding layers. Where a photonic structure includes a plurality of waveguiding layers, the plurality of waveguiding layers can be provided at a common elevation or at different elevations.

[0043] In one embodiment, a photonic structure can include a photodetector formed of germanium adjacent to a silicon layer. In particular, this disclosure describes a method that eliminates the need for low-temperature buffer layers between the germanium formation and the layer formed of silicon. In one embodiment, the germanium photodetector material can be formed using a process wherein volumes of germanium are iteratively deposited and in-situ annealed.

[0044] In one embodiment, the disclosed photodetector includes a via top contact arrangement wherein a spacing distance between a germanium formation perimeter (in contact with trench oxide) and an ion implantation region perimeter can be equal to or greater than a threshold distance. In another aspect a spacing distance between an ion implantation region perimeter and a contact perimeter can be equal to or greater than a threshold distance. Providing a photodetector to include a substantial trench to ion implantation region distance and trench to contact distance can avoid formation of leakage paths about a formed photodetector.

[0045] In one embodiment a top most contact wiring layer of a fabricated photodetector can be formed of an appropriate metal contact. The termination wiring layer formed of an appropriate metal contact can be adapted to accommodate wiring bonds and allow for improved temperature-dependent operation.

[0046] In one embodiment, a dual damascene process can be employed for fabrication of a wiring layer, where connecting vias and wiring trenches are produced in separate patterning steps, but filled with a conductive metal material and planarized with a common deposition and planarization process.

[0047] In one embodiment, a method of fabricating a photonic structure can include forming a layer of dielectric material over a waveguide, etching a trench in the layer of the dielectric material, epitaxially growing germanium within the trench, annealing germanium formed by the epitaxially growing, repeating the epitaxially growing and annealing until formed germanium sufficiently overfills the trench, and planarizing a portion of the germanium that overfills the trench. Processes for fabrication of n and p regions, contact interfaces, and contacts can be performed to define a photonic structure having a photodetector.

[0048] Epitaxially grown and annealed germanium may contain doped or undoped portions. Where a semiconductor structure includes intrinsic germanium, a semiconductor structure can define a p-i-n or n-i-p photodetector structure by in-situ doping or other ion-implantation methods. In one embodiment, a vertical photodetector can be formed on a silicon-on-insulator (SOI) wafer, wherein a top silicon layer of the SOI wafer can be etched to define a silicon waveguide. In one aspect a formed photodetector can include germanium and silicon and can be absent a low-temperature silicon germanium (SiGe) or Ge buffer between the silicon and the germanium.

[0049] In one aspect, a photonic structure and method of fabrication can be provided wherein waveguides of different geometries can be fabricated over a thick buried-oxide (BOX) silicon-on-insulator (SOI) wafer. In one embodiment, waveguides of different geometries and/or sizes can be fabricated by patterning of a layer of waveguiding material. In one embodiment, waveguides of different geometries and/or sizes can be fabricated by patterning of a layer of waveguiding material where the layer of waveguiding material can be provided by a top layer of a SOI wafer. In one embodiment, there can be used one or more layer of hardmask material e.g. silicon dioxide (SiO₂) for fabrication of waveguides.

[0050] Referring to FIG. 1 there is shown a pre-constructed silicon on insulator (SOI) wafer 102 appropriate for the fabrication of photonic structures. SOI wafer 102 can include a substrate 100 formed of silicon, a layer 110 formed of a dielectric material, e.g. oxide and layer 210 formed of silicon. SOI wafer 102 can be a photonics modified SOI wafer having layer 110 which can be a thickened oxide layer for suppressing propagation losses in substrate 100. Layer 110 in one embodiment can include a thickness of between about 1 μm and about 4 μm. Layer 210 of a photonic optimized SOI wafer in one embodiment can be formed of intrinsic (undoped) or lightly-doped crystalline silicon. Layer 110 and layer 210 of SOI wafer 102 can be fabricated e.g. by wafer bonding or implantation of oxygen followed by annealing.

[0051] Further referring to FIG. 1, the top silicon layer 210 can be tailored to the thickness desired by photonics design e.g. by epitaxial growth (thickening), or chemical etching or oxidation and oxide removal (thinning).

[0052] In one aspect, photonic structure 10 can include formed waveguides of one or more different geometries and/or one or more different sizes. In reference to FIGS. 1-12 there is described fabrication of a photonic structure 10 in one particular embodiment wherein waveguides e.g. waveguides 2101, 2102 and 2103 of multiple geometries and multiple minimal thicknesses can be fabricated from a

single layer of silicon, e.g. layer 210. In one embodiment, layer 210 can be provided by a top layer of SOI wafer 102 formed of silicon.

[0053] A method of fabrication of a photonic structure having one or more waveguide is described with reference to FIGS. 1-12.

[0054] Referring to FIG. 1 there is shown a SOI wafer 102 having a layer 100 provided by silicon substrate, layer 110 which can be provided by buried oxide (BOX), and layer 210 which can be provided by intrinsic (undoped) or lightly-doped silicon.

[0055] FIG. 2 illustrates an exemplary photonic structure 10 having a layer 210 which can be regarded as a waveguiding layer and patterning for fabrication of multiple single-crystalline silicon waveguides. The figure depicts photonic structure 10 after multiple patterning and partial etching of waveguiding layer 210 which can be formed of silicon, as well as removal of a softmask material, achieved using layer 211 which can be a thin layer formed of first hardmask material. Layer 211 can assist in maintaining the lithography feature definition, preventing attack of the remaining full-height silicon of waveguiding layer 210 during the etch process, and can allow for sufficient removal of dry-etching residue in both in-situ and ex-situ cleaning. Not shown here are intermediate steps, such as lithography and softmask patterning.

[0056] Similar to FIG. 2, FIG. 3 illustrates a second exemplary photonic structure 10 consisting of multiple types of single-crystalline silicon waveguides. The figure depicts photonic structure 10 after patterning and complete etching of waveguiding layer 210 which can be formed of silicon, as well as removal of the softmask (e.g. organic stack) material, achieved using a layer 214 which can be a thin layer formed of second hardmask material. Layer 214 which can be hardmask material can also assist in maintaining the lithography feature definition, preventing attack of the top surface of waveguiding layer 210 during the etch process, and can allow for sufficient removal of dry-etching residue in both in-situ and ex-situ cleaning. Also, not shown here are intermediate steps, such as lithography and softmask patterning.

[0057] Use of one or more of layer 211 or layer 214 which can be formed of hardmask material can reduce defects in fabricated waveguides. It was observed that reactive ion etching (RIE) can result in polymer residue formations on sidewalls of softmasks, hardmasks, and final features. It was further observed that cleaning of polymer residue formations without layers 211 and 214, can introduce abnormal surface defects into waveguiding layer 210 defining formed waveguides by micro-masking in further processing. In addition, polymer residue embedded between waveguiding layer 210 formed of silicon and layer 120 formed of oxide (FIG. 4) can introduce a substantial increase in propagation loss in the communications band (about 1.3 μm to about 1.55 μm). Use of one or more of layer 211 or layer 214 can protect waveguiding layer 210 from damage (e.g. via silicon consumption) when cleaning processes are performed for removal of polymer residue formations. In another aspect layers 211 and 214 formed of hardmask material can serve as a screening layer for ion implantation for formation e.g. of contacts, sub-contacts, photonics or CMOS junctions. Regarding patterning of waveguiding layer 210, patterning of waveguiding layer 210 can be performed using a stack of organic lithography material (a mask) formed over one or

more or layer 211 or layer 214. There is set forth herein a method including forming a stack of hardmask material over a layer of waveguiding material; depositing a stack of softmask material formed of organic lithography material over the stack of hardmask material; and patterning the stack of organic lithography material, wherein the patterning includes stopping at the stack of hardmask material. One or more of layer 211 or layer 214 as set forth herein can be formed of hardmask material, e.g., silicon dioxide (SiO₂).

[0058] Referring to FIG. 4, high aspect ratio processing (HARP) or other low loss dielectric such as plasma enhanced chemical vapor deposition (PECVD) TEOS can be performed for the formation of a layer of dielectric material that surrounds a fabricated waveguide. Layer 1201 can be formed about waveguides 2101, 2102, and 2103 defined by waveguiding layer 210. In one embodiment, layer 1201 can be formed of a non-conformal oxide material. Use of a non-conformal oxide material for layer 1201 can reduce an incidence of voids and other defects in oxide that surrounds waveguides 2101, 2102, and 2103. A non-conformal oxide material can be a material that is adapted to deposit at a higher rate on horizontal surfaces while exhibiting a suppressed sidewall deposition rate. In one embodiment of a method for providing non-conformal oxide material, a deposition of oxide material can be plasma enhanced. It can be envisioned (but is not depicted) that with use of conformal material for layer 1201, pinch off can occur when layer 1201 is deposited over high aspect ratio features and accordingly can result in introduction of voids with oxide surrounding waveguides 2101, 2102, and 2103.

[0059] Further referring to FIG. 4, the photonic structure 10 is shown after planarization of a dielectric layer 1201 and capping with a dielectric layer 1202 for providing the correct total thickness of dielectric material of layer 120 for further processing. On planarization of layer 1201 a top elevation of layer 1201 can be reduced. On planarization of layer 1202 a top elevation of layer 1202 can be reduced.

[0060] With use of the fabrication stages described with reference to FIGS. 1-12, waveguides of multiple different geometries and multiple minimal heights can be defined by layer 210 of SOI wafer 102. Waveguide 2101 can be a ridge waveguide having first minimal thickness. Waveguide 2102 can be a ridge waveguide having a second minimal thickness greater than the first minimal thickness. Waveguide 2103 can be a rectangular waveguide having a third minimal thickness greater than the second minimal thickness.

[0061] Referring to FIG. 5, photonic structure 10 in one embodiment can include waveguides defined in multiple layers of common or dissimilar material. Exemplary photonic structures 10 as set forth herein can include one to four or more levels of waveguiding layers with one to two or more waveguiding materials in each level. Waveguides fabricated of different materials within a photonic structure 10 can be used for the performance of different functions. For example, silicon is easily adapted for conducting electrical current and accordingly waveguides formed of silicon can be used to include active devices such as photodetectors and other photonic components. Dielectric waveguides (such as silicon nitride) can be adapted for transmission of light waves over longer distances owing to a reduced figure of absorption in the communications wavelength range. Waveguides fabricated of other materials such as amorphous silicon or polycrystalline silicon can have a balance of electrical and optical properties and can be particularly

useful for functions having a balance of current conduction and distance light transmission aspects.

[0062] To aid in the fabrication of a photonic structure 10 having waveguides defined by different waveguiding layers, photonic structure 10 can include layers in the form of one or more dielectric separating layers in the form of films between layers of different material.

[0063] Referring to FIG. 5 dielectric layer 1201 which can be regarded as a cladding layer can be a gap-filling cladding oxide that can be planarized by the application of a polishing process, while capping layer 1202 can be a second distance correcting low temperature oxide film. There can be provided a dielectric layer in the form of capping layer 1202 above the dielectric layer 1201 to provide corrected dielectric separation distance to one or more additional waveguiding layer.

[0064] In one embodiment, capping layer 1202 can be designed to enhance the fabrication and the operation of one or more additional waveguides defined within a waveguiding layer formed of waveguiding material formed above a waveguiding layer 210 formed of waveguiding material defining one or more base waveguides. Where capping layer 1202 supports one or more device layer above layer 1202, layer 1202 can be regarded as a dielectric separation layer of compatible optical properties. Layer 1202 can provide physical and optical isolation between waveguiding layers e.g., waveguiding layer 210 and waveguiding layer 310 in which waveguides can be defined. Layer 1202 can provide a separation between waveguiding layers that can be tailored for isolation or intentional optical coupling. Layer 1202 can provide corrected dielectric separation distance between waveguiding layers. Material of layer 1202 can be selected to provide low propagation loss and optimize process compatibility, especially with regard to temperature.

[0065] Further referring to FIG. 5, an exemplary fabricated photonic structure 10 wherein the photonic structure 10 includes multiple waveguides is illustrated. Layer 120 can be formed of dielectric material and can include in the specific embodiment layer 1201 formed of dielectric material surrounding waveguides (e.g. waveguide 2101 and waveguide 2102) defined by waveguiding layer 210 and waveguiding layer 410 (e.g. waveguide 4101) and layer 1202 serving as dielectric capping layer formed on the cladding layer 1201 surrounding waveguides defined by waveguiding layer 210 and waveguiding layer 410. Layer 120 in the embodiment of FIG. 5 can further include layer 1201 formed of dielectric material surrounding waveguides defined by layer 420 (e.g. waveguide 4201) and layer 1202 serving as an dielectric capping layer formed on the layer 1201 surrounding waveguides defined by waveguiding layer 420. Layer 120 in the embodiment of FIG. 5 can further include layer 1201 formed of dielectric material surrounding waveguides (e.g. waveguide 3101) defined by waveguiding layer 310, and layer 1202 serving as an dielectric capping layer formed on the layer 1201 surrounding waveguides defined by waveguiding layer 310. Layer 120 in the embodiment of FIG. 5 can further include layer 1201 formed of dielectric material surrounding waveguides defined by waveguiding layer 320 (e.g. waveguide 3201), and layer 1202 serving as a dielectric capping layer formed on the layer 1201 surrounding waveguides defined by waveguiding layer 320. Layer 120 in the embodiment of FIG. 5 can further include layer 1201 formed of dielectric material surrounding waveguides defined by waveguiding layer 330

(e.g. waveguide 3301), and layer 1202 serving as a dielectric capping layer formed on the layer 1201 surrounding waveguides defined by waveguiding layer 330. Layers 1201 can be regarded as cladding layers and layers 1202 can be regarded as capping layers. Layers 1201 and layers 1202 can be formed of dielectric material e.g. oxide.

[0066] Referring to FIG. 5, waveguides 2101 and 2102, waveguides 3101, 3201, and 3301, and waveguides 4101 and 4201 can be encapsulated within layer 120. Referring to FIG. 5, a bottom of waveguide 2101 and waveguide 2103 can be formed at elevation 1102, a bottom of waveguide 4201 can be formed at elevation 1104, a bottom of waveguide 3101 and waveguide 3201 can be formed at elevation 1106 and 1108, respectively. A bottom of waveguide 3301 can be formed at elevation 1110. Waveguides of the photonic structure 10 as set forth in FIG. 5 can be formed of different materials. Waveguide 2101 and waveguide 2102 can be formed of single-crystalline silicon, and waveguide 3101, 3201, and 3301 can be formed of silicon nitride. Waveguides 4101 and 4201 can be formed of amorphous or polycrystalline silicon. Waveguides of photonic structure 10 can have different geometries. Waveguide 2101 as shown in FIG. 5 can have a ridge geometry. Waveguides 2102, 4101, 4201, 3201, 3301 can have rectangular geometries.

[0067] In reference to FIG. 5 there is set forth a photonic structure 10 having photonic layer 210, photonic layer 420, photonic layer 310, and photonic layer 320. In one embodiment, the layers 210, 420, 310, and 320 can be regarded as first, second, third and fourth photonic layers. In one embodiment, each of the layers 210, 420, 310, and 320 can be formed at a different elevation. Photonic structure 10 can include less than or greater than the noted number of photonic layers. In one embodiment as set forth in FIG. 5, photonic structure 10 can include photonic layer 330 at an elevation different than an elevation of each of layers 210, 420, 310, and 320. Photonic layer 330 can be regarded as a fifth photonic layer.

[0068] Referring to FIG. 6 through FIG. 10, exemplary fabrication of different waveguides of photonic structure 10 having characteristics of the photonic structure 10 are shown. Referring to FIG. 6, photonic structure 10 can include waveguide 2101, waveguide 2103 and layer 120 formed over waveguide 2101 and waveguide 2103 wherein layer 120 can be formed of a dielectric, e.g., oxide material. Layer 120 in one embodiment can include a combination of layer 1201 which can be regarded as a cladding layer and layer 1202 which can be regarded as a capping layer as set forth herein. Waveguide 2101 and waveguide 2103 can be patterned in and defined by common waveguiding layer 210.

[0069] Further referring to FIG. 6, there can be formed waveguiding layer 310 over layer 120. Waveguiding layer 310 can be a nitride waveguiding layer for use in patterning waveguides. Referring to FIG. 7, FIG. 7 illustrates the photonic structure 10 of FIG. 6 after planarization of waveguiding layer 310. Waveguiding layer 310 can be utilized in the fabrication of a nitride waveguide, e.g., formed of silicon nitride (SiN).

[0070] In one embodiment, plasma enhanced chemical vapor deposition (PECVD) can be employed for deposition of silicon nitride forming layer 310. PECVD can be performed with use of reduced thermal budget, e.g., at a temperature in a temperature range of from about 300 degrees Celsius to about 500 degrees Celsius. It was observed that certain photonic device fabrication flows

cannot sustain thermal treatments of that nature. Accordingly, PECVD silicon nitride can be advantageous.

[0071] Use of PECVD processing for deposition of waveguiding layer 310 formed of silicon nitride can be combined with additional processes for reducing the optical absorption of formed nitride. For example, layer 1202 which can provide a capping layer formed of oxide and waveguiding layer 310 which can be formed of nitride can be subject to controlled fabrication process, e.g., chemical-mechanical polishing processes to smooth the surfaces of the oxide and nitride layers. Furthermore, deposition conditions can be controlled to adjust properties of formed material. Exemplary deposition adjustments can include the alteration of substrate temperature, plasma power, forward bias, chamber pressure conditions, and precursor flow ratios. The indicated condition changes greatly depend on the chamber configuration and exact nature of precursors, and are therefore omitted from this disclosure. It is noted, however, that stoichiometric silicon nitride, i.e., nitride with a 3:4 silicon-to-nitride ratio, can be attained under a multitude of process conditions, and a great degree of freedom exists to tailor the optical properties to the desired values (refractive index \approx 2.0 and low propagation losses $<$ 0.5 db/cm). Further annealing processes can be performed on waveguiding layer 310 to remove contaminants and gaseous inclusions, thus further improving structural and optical properties.

[0072] In addition, formed nitride waveguides can be subject to line edge roughness treatment. A steam or high-pressure oxidation at moderate to high temperatures can convert the few outermost nanometers of the silicon nitride to silicon dioxide. After removal of said silicon dioxide in an aqueous hydrofluoric acid solution, the average surface roughness of the silicon nitride is improved.

[0073] It was observed that silicon nitride waveguides can have indices of refraction (near 2.0) close to indices of refraction of a surrounding dielectric material (1.45) and accordingly can co-transmit a relatively larger portion of the propagating light waves in a surrounding dielectric material. Defects (voids) and optical absorption in dielectric material surrounding formed waveguides can be particularly important in the case of nitride waveguides. Low overall levels of optical propagation loss can only be maintained with use of appropriate dielectric cladding material, e.g., gap-filling low-temperature oxide as set forth herein.

[0074] FIG. 7 depicts the photonic structure 10 after chemical-mechanical polish to smooth the top surface of waveguiding layer 310 formed of silicon nitride.

[0075] Referring to FIG. 8, the photonic structure 10 is shown after patterning of waveguiding layer 310 to form waveguides 3101 which can be followed by line-edge roughness mitigating treatment. The processing performed can be wet oxidation followed by a brief immersion in an HF-based solution to remove the resulting oxide on the surface of nitride waveguides 3101.

[0076] In a similar fashion, FIG. 9 illustrates the photonic structure 10 shown in FIG. 8 after forming of layer 120 over patterned sections of waveguiding layer 310. Layer 120 can include layer 1201 which can be a deposited cladding layer formed of oxide and layer 1202 which can be a deposited capping layer formed of oxide. Layer 1201 can extend to an elevation above a top elevation of waveguide 3101 and waveguide 3102. Further referring to FIG. 9 there can be formed on layer 120, waveguiding layer 410. Waveguiding layer 410 in one embodiment can be an amorphous or

polycrystalline silicon layer for use in fabrication of one or more waveguide formed of amorphous silicon or polycrystalline silicon, subsequently subjected—but not shown—to a smoothing polish, patterning to define waveguide features, and line-edge roughness mitigation treatment.

[0077] Line edge roughness treatments for silicon waveguides e.g. waveguide 2101 or waveguide 2103 may also include techniques such as H₂ annealing using reduced pressure chemical vapor deposition (RPCVD) or rapid thermal chemical vapor deposition (RTCVD) processing or depositing epitaxial silicon on silicon waveguides. The H₂ annealing can be performed at a temperature of between about 700 degrees Celsius and about 950 degrees Celsius and at a pressure of from about 1 Torr to about 1 Atmosphere. In one example the annealing condition can include a temperature of about 900 degrees Celsius and a pressure of about 100 Torr.

[0078] Referring to FIG. 10, a photonic structure 10 is schematically depicted after patterning of waveguiding layer 410 to define waveguides 4102 and after formation of a section of layer 120 over waveguiding layer 410. As shown in FIG. 10, layer 120 can include layer 1201 which can be a cladding layer surrounding waveguides 4102 defined by waveguiding layer 410 and layer 1202 formed on layer 1201 surrounding waveguides 4102 defined by waveguiding layer 410. Layer 1201 and layer 1202 can be formed of dielectric material, e.g., oxide.

[0079] FIGS. 11 and 12 illustrate a method for fabricating exemplary implementation of photonic structure 10 as shown in FIG. 8 having waveguides of different materials (e.g. waveguides 3101 and 4001) formed at a common elevation.

[0080] Referring to FIG. 11, layer 130 which can be a thin dielectric material and layer 400 which can be formed of amorphous silicon or polycrystalline silicon can be deposited conformally over dielectric layer 120 and waveguides 3101 (not shown). Referring further to FIG. 11, the exemplary photonic structure 10 is depicted after a treatment of planarization that serves to correct the thickness of waveguiding layer 400, smooth the top surface of waveguiding layer 400, and remove almost completely excess material of waveguiding layer 400 over waveguides 3101 defined in waveguiding layer 310.

[0081] Referring to FIG. 12, the exemplary photonic structure 10 as illustrated in FIG. 11 is shown after patterning of waveguiding layer 400 to define waveguide 4001. Waveguiding layer 400 can be formed of amorphous silicon or polycrystalline silicon. Further referring to FIG. 12, waveguide 3101 and waveguide 4001 formed of different materials can be formed at a common elevation, disregarding the finite thickness of layer 130. Structures e.g. first and second waveguides can be regarded to have a common elevation herein if an imaginary horizontal plane extending parallel to substrate 100 can extend through the structures e.g. the first and second waveguide. In one embodiment, layer 130 can be omitted prior to formation of layer 400, resulting in the bottom of waveguide 3101 and a bottom of waveguide 4001 to be formed at a common elevation. Omission of layer 130 is challenging but possible owing to the material dissimilarities between layer 310 and layer 400.

[0082] In one embodiment, photonic structure 10 can be adapted for detection of light in the communications wavelength range. A flow diagram illustrating a method for fabricating a photonic structure 10 having a photodetector is

illustrated in FIG. 13. According to a method in one embodiment, there is performed at block 402 forming a layer of dielectric material over a silicon waveguide and at block 406 etching a trench in the layer extending to the silicon waveguide. There can be performed at block 412 epitaxially growing germanium within the trench and at block 416 annealing germanium formed by the epitaxial growing. There can be performed repeating of the epitaxial growing and annealing until the germanium overfills the trench sufficiently (block 420).

[0083] As a result of performance of the method of FIG. 13 there can be formed a germanium-based photodetector that can be absent of a low-temperature buffer layer connecting the germanium formation to the silicon surface. The resulting photonic structure 10 defining a photodetector provides for low leakage current and increased signal to noise ratio.

[0084] Further aspects of the method of FIG. 13 are described with reference to FIGS. 14-17 showing a photonic structure in various intermediary stages of fabrication. There is set forth herein a silicon photonic structure and process wherein vertical photodetector integrated on a silicon-on-insulator (SOI) wafer 102. In one embodiment, a vertical photodetector can be integrated on a SOI top silicon waveguiding level by patterning trenches within a layer of dielectric material, e.g., oxide, filling with crystalline germanium, planarizing the overfill of the germanium, and forming top and bottom contacts.

[0085] FIG. 14 depicts photonic structure 10 in an intermediary stage of fabrication that illustrates performance of block 402 (forming dielectric material over a silicon waveguide) and block 406 (patterning a trench). Photonic structure 10 can include a substrate 100 formed of silicon, a layer 110 formed of buried oxide, a waveguide 2105 of which a detector plateau section is shown in FIG. 14, a waveguide 2103, and a layer 1201 which can be a cladding layer formed of dielectric material e.g. oxide formed over waveguide 2105 and waveguide 2103, which waveguides can be patterned in and defined by waveguiding layer 210 which can be formed of silicon. Layer 120 formed over waveguide 2105 and waveguide 2103 can include layer 1201 which can be a cladding layer and layer 1202 which can be a capping layer. Layer 1201 and layer 1202 can have a combined thickness of greater than about 500 nm, and in one embodiment between about 500 nm and about 1500 nm. In one embodiment, cladding layer 1201 in combination with a capping layer 1202 has a combined thickness of about 1000 nm so that a height of a formed photodetector structure has a height of about 800 nm to about 1000 nm.

[0086] Further details of block 406 (formation of trench) are set forth with reference to FIG. 14. Photonic structure 10 as shown in FIG. 14 is illustrated after formation of a detector trench 610 which can be patterned to extend to an underlying silicon waveguide 2105. Patterning may be performed using e.g. one or more of lithography, dry etching, or wet chemical processing. In one embodiment, a formed trench 610 can have a depth of greater than about 500 nm, and in one embodiment in the range of from about 500 nm and about 1500 nm. In one embodiment, trench 610 can have a depth of about 800 nm to about 1000 nm.

[0087] Further details of block 412 (epitaxially growing), block 416 (annealing), and loop 420 (repeating of epitaxial growing an annealing) are set forth with reference to FIG. 15

illustrating a photonic structure **10** in an intermediary stage of fabrication wherein a germanium formation **640** overfills trench **610**.

[0088] Prior to performance of block **412** (epitaxially growing of germanium) the photonic structure **10** as shown in FIG. **14** can be subject to an ex-situ and/or in-situ surface cleaning process consisting of a wet chemical or dry native oxide removal followed by a short in-situ high-temperature bake in a reducing hydrogen atmosphere. The latter can be responsible for removing sub-stoichiometric surface oxide reformed by exposure to air between the cleaning tools and epitaxial reactor.

[0089] FIG. **15** illustrates the photonic structure of FIG. **14** after formation of germanium within a trench **610**. By epitaxial growing and annealing of germanium, trench **610** patterned in layer **120** can be filled with doped or intrinsic crystalline germanium.

[0090] Referring to block **412** (epitaxially growing) and block **416** (annealing) sections of germanium can be selectively grown and annealed within trench **610**. In one embodiment, germanium can be selectively grown at block **412** using reduced pressure chemical vapor deposition (RPCVD). Referring to block **412** (epitaxially growing of germanium) a multi-step high-rate deposition process can be performed at a temperature of between about 550 to about 850 degrees Celsius and at a pressure of between about 10 Torr and about 300 Torr using germane and H₂ as the precursor and carrier gas, respectively. The temperature can be a stable temperature or a variable temperature. The pressure can be a stable pressure or a variable pressure. Epitaxially growing at block **412** can be performed without use of a doping gas (e.g. diborane for p-type, arsine or phosphine for n-type). At block **412** in one particular embodiment, about 200 nm of intrinsic (or doped) Ge can be grown selectively (to elevation **621**) using germane and hydrogen at a temperature in the temperature range of between about 550 degrees Celsius to about 700 degrees Celsius and at a pressure in the temperature range of between about 10 Torr to about 25 Torr.

[0091] Referring to block **416** (annealing) in one embodiment a deposition chamber can be purged and the germanium deposited by epitaxially growing at block **412** can be annealed at a temperature of between about 650 degrees Celsius to about 850 degrees Celsius and at a pressure of between about 100 Torr and about 600 Torr (300 Torr in one embodiment). The temperature can be a stable temperature or a variable temperature. The pressure can be a stable pressure or a variable pressure.

[0092] A germanium film formed by epitaxially growing and annealing can include intrinsic germanium or doped germanium. For doping of formed germanium, dopant gases (such as diborane, phosphine, arsine) can be added to the source gas, e.g., H₂, used during RPCVD epitaxial growing.

[0093] Referring to FIG. **13**, block **410** and block **416** (epitaxially growing and annealing) can be repeated until (block **420**) deposited germanium sufficiently overfills trench **610**. In one embodiment, an overfill can be regarded to be sufficient when an overfill allows appropriate corner coverage. In one embodiment, six epitaxially growing and annealing cycles (about 200 nm each) can be used to overfill trench **610**. For example, after a first (initial) epitaxially growing and annealing cycle, deposited germanium can extend to elevation **621** as shown in FIG. **15**. After a second epitaxially growing and annealing cycle, deposited germanium

can extend to elevation **622**. After a third epitaxially growing and annealing cycle, deposited germanium can extend to elevation **623**. After a fourth epitaxially growing and annealing cycle, deposited germanium can extend to elevation **624**. After a fifth epitaxially growing and annealing cycle, deposited germanium can extend to elevation **625**. After a sixth epitaxially growing and annealing cycle, deposited germanium can extend to elevation **626** and can overfill trench **610** as is depicted in FIG. **15**. The misfit of the Ge to the Si lattice due to atomic size results in a vast amount of strain-related crystal defects that can extend well past the initial growth interface. The annealing within each growing and annealing cycle can serve to annihilate dislocations and other extended defects inside formed germanium of germanium formation **640**.

[0094] As noted epitaxially growing (block **412**) and annealing (block **416**) can be repeated in a cycle until the desired fill height is achieved which can occur e.g. when deposited germanium sufficiently overfills trench **610**. It was observed that epitaxial germanium can grow at much reduced rates in the <110> and <111> crystal directions relative to the vertical <100> direction. This lag in epitaxial growth near the edges and corners of trench **610** can be overcome by overfilling trench **610**. In one embodiment, an overfill of about 1.0 μm can be used to ensure high quality fill of trench edges and corner points. After six cycles in the embodiment depicted in FIG. **15**, the top of the <100> Ge growth front has reached the top of trench **610**. For final processing, a 0.5 μm overfill deposition/annealing cycle followed by a 0.5 μm final growth can be employed to finalize the Ge fill. Finalizing the growth/annealing sequence with growth rather than annealing can be advantageous due to observed redistribution of the Ge feature, especially near the corner points.

[0095] In an alternative method described with reference to the intermediary fabrication stage depicted in FIG. **15**, a silicon germanium (SiGe) or Ge buffer layer can be formed on a top surface of silicon waveguide **2105** prior to formation of germanium (Ge). A SiGe or Ge buffer can be deposited using reduced pressure chemical vapor deposition (RPCVD) at temperatures in the range of from about 300 degrees Celsius to about 450 degrees Celsius. Such processing can be useful in various embodiments. In one embodiment, a formed SiGe or Ge buffer can be in-situ doped (n-type or p-type). For formation of a SiGe or Ge buffer, silane (SiH₄) can be used as Si source gas and germane (GeH₄) can be used as a Ge source gas. For formation of doped buffer layer, diborane (B₂H₆), phosphine (PH₃), or arsine (AsH₃) can be used as doping gases. However, it was observed that the aforementioned low temperature range can furnish excessively low growth rates and can necessitate disproportionately long process durations. In addition, reactor and gas purity requirements can become increasingly stringent as temperature is lowered.

[0096] With the method set forth in reference to FIG. **13** a resulting photonic structure **10** can be absent of a challenging low-temperature SiGe or Ge buffer and can rather include germanium formed adjacent to and directly on a waveguide e.g. waveguide **2105** which can be formed of silicon. According to the method provided in FIG. **13**, the formed photonic structure **10** for use in a photodetector structure that is absent a low-temperature SiGe or Ge buffer can feature a reduced amount of extended defects and

therefore reduced reverse leakage current—important for efficiency and speed of detection of light.

[0097] The method of FIG. 13 is particularly adapted for use in creating germanium formations in trenches having widths of less than about 150 m. Trenches having widths of greater than about 150 μm can exhibit a reduced fill height as well as severe surface roughening. Because common optical device trench widths in photonic devices are less than about 10 m, the method is well suitable for use with a wide range of photonic devices. It was observed that restricting an area for growth of germanium e.g. to an area defined by a width of trench 610 can reduce formation of anomalous features and can facilitate growth of germanium on a layer of silicon without a low-temperature SiGe or Ge buffer between a germanium formation and a silicon layer. Trench 610 can have a width of less than about 10 μm and in one embodiment can feature excellent fill character to widths as small as 200 nm or smaller.

[0098] Referring again to the flow diagram of FIG. 13 planarization processing can be performed subsequent to block 420. FIG. 16 illustrates the photonic structure of FIG. 15 after planarizing of germanium. An overfill portion of germanium can be removed and planarized so that a top elevation of a germanium formation 640 can be in common with a top elevation of layer 1202 which can be a capping layer. A chemical mechanical planarization (CMP) process can be used for performance of planarization. A CMP process can be used that selectively removes Ge with insignificant erosion of layer 1202 which can be formed of oxide. An overgrown germanium formation 640 can exhibit a mushroom like structure as shown in FIG. 15 with well-defined facets and sharp corners and crests. For removal of such features, a CMP process can include using a modified slurry (hydroxide based) and a first soft pad followed by the use of second hard (or standard) pad.

[0099] Subsequent to planarizing, the photonic structure 10 as depicted in FIG. 16 can be subject to further processing to complete fabrication of a photodetector structure. FIG. 17 illustrates the photonic structure of FIG. 16 after formation of top contact ion implantation region 650, depositing of a layer 1203 formed of dielectric material e.g. oxide over layer 1202, and patterning and filling of a trench shown occupied by conductive material formation 712 with a conductive material formation 712. Layer 120 formed of dielectric material can include layer 1201 which can be a cladding layer, layer 1202 which can be a capping layer, and layer 1203 which can be a contact spacer layer. Further in reference to FIG. 17 a bottom contact ion implantation region 660 can be formed in waveguide 2105 of layer 210 prior to the construction of dielectric layer 120 and trench 610 defined in layer 120. In an alternative embodiment, a bottom contact ion implantation region 660 can alternatively be formed in germanium formation 640. In an alternative embodiment, a bottom contact ion implantation region 660 can alternatively be formed partially in waveguide 2105 and partially in germanium formation 640. Formation of ion implantation region 650 and ion implantation region 660 in germanium formation 640 or in a structure adjacent to germanium formation 640 as set forth herein defines a p-i-n photodetector structure (p region at bottom) or n-i-p photodetector structure (n region at bottom).

[0100] In one aspect, a location of ion implantation region 650 can be restricted to a reduced area of germanium formation 640. Ion implantation region 650 in one embodi-

ment can be defined within a perimeter 651. In one aspect, ion implantation region 650 can be formed to have a trench to ion implantation region spacing distance D_1 equal to or greater than a threshold distance, L_1 . Spacing distance D_1 can be the distance between perimeter 651 of ion implantation region 650 and the perimeter 641 of germanium formation 640 (in contact with layer 120 which can be formed of oxide). Because perimeter 641 of germanium formation 640 can be in contact with layer 120 that can define trench 610, the spacing distance D_1 can also be the distance between perimeter 651 of ion implantation region 650 and trench 610. In one embodiment, spacing distance D_1 can be substantially uniform throughout a top area of germanium formation 640 and can be in a direction extending normally to perimeter 651 of ion implantation region 650 and perimeter 641 of germanium formation 640. In such embodiment, the spacing distance D_1 can be equal to or greater than the noted threshold distance throughout an entirety of perimeter 651 of ion implantation region 650 and the entirety of perimeter 641 of germanium formation 640. In one embodiment L_1 is 100 nm; in another embodiment 200 nm; in another embodiment 300 nm; in another embodiment 400 nm, in another embodiment 500 nm; in another embodiment 600 nm; in another embodiment 700 nm; in another embodiment 800 nm; in another embodiment 900 nm; in another embodiment 1.0 m. A spacing distance D_1 can be designed based on, e.g., dimensional widening of features during processing, minimum printable feature dimensions, and reliable maximum feature printing misalignment.

[0101] A silicon photonic structure and process is set forth herein where the germanium photodetector structure may contain a reduced area top ion implantation region 650 of the opposite polarity compared to the bottom ion implantation region 660. By forming ion implantation region 650 to have a trench to implantation spacing distance of D_1 an incidence of leakage current paths can be reduced. Reverse leakage current densities of less than about 1 nanoamperes per square micrometer can be achieved in one embodiment using top ion implantation region 650 spaced to a trench to implantation region spacing distance D_1 of equal to or greater than a threshold distance L_1 of 0.75 μm from the oxide trench (at perimeter 651) on each edge. Doses and energies can be tailored for producing a shallow ohmic contact to the conductor contact provided by conductive material formation 712, and a thin implant screening oxide can be employed to avoid Ge sputter removal. In one embodiment, ion implantation region 650 can be formed to define a shallow top ion implantation.

[0102] Further referring to FIG. 17, a trench shown occupied by conductive material formation 712 can be formed in layer 1203. Subsequently to formation of such trench, a conductive material formation 712 can be formed in the trench shown occupied by conductive material formation 712. For patterning of the trench shown occupied by conductive material formation 712, layer 150 formed of hard-mask material can be formed over layer 1203. Layer 150 in one embodiment can have a thickness of from about 5 nm to about 150 nm and can be formed of dielectric hardmask material (e.g. silicon dioxide) and can serve to enhance dry etching performance and furnish a stopping layer in a subsequent conductor polishing process. Conductive material formation 712 can be formed of semiconductor-compatible metallization material that is reflective to wavelengths in the range of from about 900 nm to about 1600 nm.

Conductive material formation **712** can be a germanide-free (refractory) conductive material formation. In one aspect, the trench shown occupied by conductive material formation **712** can be patterned so that conductive material formation **712** has a perimeter **713** that is spaced apart from a perimeter **651** of ion implantation region **650**. Referring to FIG. **17**, spacing distance D_2 can be the distance between perimeter **713** of contact formation **712** and perimeter **651** of ion implantation region **650**. In one embodiment, the spacing distance D_2 can be equal to or greater than a threshold distance L_2 . In one embodiment, spacing distance D_2 can be substantially uniform throughout an area of ion implantation region **650** and can be in a direction extending normally to perimeter **713** of contact formation **712** and perimeter **651** of ion implantation region **650**. In such embodiment, the spacing distance D_2 can be equal to or greater than the noted threshold distance throughout an entirety of perimeter **713** of conductive material formation **712** and the entirety of perimeter **651** of ion implantation region **650**. In one embodiment L_2 is 100 nm; in another embodiment 200 nm; in another embodiment 300 nm; in another embodiment 400 nm, in another embodiment 500 nm; in another embodiment 600 nm; in another embodiment 700 nm; in another embodiment 800 nm; in another embodiment 900 nm; in another embodiment 1.0 m. Forming conductive material formation **712** to be spaced from a perimeter **651** of ion implantation region **650** assures that conductive material formation **712** can be fully contained within an area of ion implantation region **650**. There is set forth herein a silicon photonic structure and process wherein a germanium photodetector structure may include a reduced area top metal conductive material formation **712** that is fully contained in an area of top ion implantation region **650**. A spacing distance D_2 can be designed based on, e.g., dimensional widening of features during processing, minimum printable feature dimensions, and reliable maximum feature printing misalignment.

[**0103**] Prior to formation of conductive material formation **712**, the trench shown occupied by conductive material formation **712** can be subject to various processes so that conductive material formation **712** can be substantially free of metal germanide phases (such as nickel germanide). Ion implantation region **650** allows for a reduced resistance connection to a germanide-free metal top contact formed of conductive material formation **712**. In one embodiment, bottom ion implantation region **660** can be formed in waveguide **2105** defined by layer **210** formed of silicon.

[**0104**] Referring to FIG. **18**, a method of fabrication of photonic structure **10** having a silicide contact interface is set forth herein. The photonic structure **10** pertains to an intermediate step of fabrication after formation of the trench shown occupied by conductive material formation **722**. The trench shown occupied by conductive material formation **722** can be formed in layer **120** which can be formed of dielectric e.g. oxide material. After formation of the trench shown occupied by conductive material formation **722**, a silicide formation **730** can be formed at a bottom of such trench, and then conductive material formation **722** can be formed in such trench.

[**0105**] In another aspect, photonic structure **10** can include a silicide formation **730**. For formation of silicide formation **730**, a metal, e.g., nickel (Ni) or nickel platinum (NiPt) layer can be sputtered into the trench shown as being occupied by conductive material formation **722** and subsequently annealed during a silicide formation stage so that the formed

metal reacts with silicon of layer **210** to form silicide formation **730** which can define a silicide contact interface. Silicide formation **730** can be formed, e.g. of nickel silicide (NiSi) or nickel platinum silicide. In areas of photonic structure **10** other than at an interface to layer **210** formed of silicon, e.g., at sidewalls defining the trench shown as being occupied by conductive material formation **722** and at a top of layer **150**, the deposited metal can remain unreacted. Prior to annealing in one embodiment, a thin capping layer (not shown, e.g., formed of titanium nitride (TiN)) can be formed over the formed nickel or nickel platinum. The thin capping layer can protect processing tools which might be negatively affected by metal evaporation. Unreacted metal (e.g., Ni, NiPt) and the thin capping layer can then be removed in an appropriate wet chemical solution. Photonic structure **10** can then be subject to further annealing in a transformation stage to transform silicide formation **730** into a low resistivity phase. The transformation stage annealing can be performed at a higher temperature than the silicide formation annealing. In one embodiment, transformation stage annealing can be performed at a temperature of between about 300 degrees Celsius and about 550 degrees Celsius. In one embodiment, the silicide formation stage annealing can be performed at a temperature of between about 350 degrees Celsius and about 500 degrees Celsius.

[**0106**] It was observed that challenges to the formation of silicide formation **730** as shown in FIG. **18** can be imposed by the configuration of the trench shown as being occupied by conductive material formation **722**. In some embodiments wherein the trench shown as being occupied by conductive material formation **722** includes a narrow width, e.g. less than about 400 nm, it was observed that formed metal, e.g. Ni, NiPt may form preferentially on a top surface of photonic structure **10** (a top of layer **150**) or sidewalls of the trench shown as being occupied by conductive material formation **722** relative to a bottom of trench at an interface to layer **210** which can be formed of silicon. In one embodiment, the trench shown as being occupied by conductive material formation **722** can include a depth of greater than about 1.3 μm and the width of greater than about 350 nm. To address such challenges, formed metal formed in the trench shown as being occupied by conductive material formation **722** for the formation of silicide can be overfilled within the trench shown as being occupied by conductive material formation **722** to assure that an appropriate volume of metal is formed at an interface to layer **210** which can be formed of silicon. In one embodiment, wherein the trench shown as being occupied by conductive material formation **722** includes depth of greater than about 1.3 μm and a width of greater than about 350 nm, of formed metal, e.g., Ni or NiPt can be deposited, e.g., via sputtering, to a depth of four times (4 \times) a desired depth at a bottom of the trench shown as being occupied by conductive material formation **722**. In one embodiment, a formed metal can be deposited to a thickness of about 40 nm at a top of photonic structure **10** as shown in the intermediary fabrication stage of FIG. **18** to yield a thickness of about 10 nm at a bottom of the trench shown as being occupied by conductive material formation **722**.

[**0107**] Further referring to FIG. **18**, the photonic structure **10** is illustrated after formation of a conductive material formation **722** in the trench shown occupied by conductive material formation **722**. Conductive material formation **722** can be formed of copper (Cu) in one embodiment by performing sputtering, plating, and a planarizing polish.

Further referring to FIG. 18, layer 151 can be deposited on layer 150 prior to formation of a contact within the trench shown as being occupied by conductive material formation 722. Layer 151 can be formed of a dielectric hardmask material (e.g., silicon nitride) to a thickness of from about 5 nm to about 150 nm and serves to enhance dry etching performance and furnish a stopping layer for a polishing process in which conductive material formation 722 can be polished.

[0108] Aspects of top metal wire layers of photonic structure 10 are described with reference to FIGS. 19 and 20.

[0109] Referring to FIG. 19, the photonic structure 10 is illustrated after formation of layer 160, patterning to form trenches shown occupied by conductive material formations 742, and filling such trenches with conductive material formations 742. Layer 160 can be formed of a dielectric material e.g. oxide and can be formed over layer 151. Trenches shown occupied by conductive material formations 742 can be formed to extend through layer 160, layer 151 and layer 150 to expose conductive material formations 712 and conductive material formations 722. Conductive material formations 722 can include, e.g., copper, densified in a low-temperature anneal, and finally planarized so that conductive material formations 742 define flat wiring assemblies 742 as are depicted in FIG. 19.

[0110] Referring to FIG. 20, the photonic structure 10 shown in FIG. 19 is depicted after formation of layer 152 on layer 160 and formations 742 and after formation of layer 170 on layer 152, followed by patterning to form trenches shown occupied by conductive material formation 752, and filling such trenches with conductive material formations 752. Layer 170 can be a dielectric material e.g. oxide and formed over layer 152 and conductive material formations 742 that define wires. Trenches shown occupied by conductive material formations 752 can extend through layer 170 and layer 152 to expose conductive material formations 742.

[0111] Conductive material formations 752 can be formed of e.g. copper, tungsten, or aluminum, densified in a low-temperature anneal, and finally planarized so that conductive material formations 752 that define wires define flat wiring assemblies. Conductive material formations 752 as set forth in FIG. 20 can be formed of aluminum (Al) in one embodiment.

[0112] Photonic structure 10 set forth in reference to FIG. 20 can include a first metallization level M1 having first conductive material formations 742 in contact with conductive material formations 712 and 722 respectively, and a second metallization level M2 having second conductive material formations 752 in contact with conductive material formations 742 respectively. In the embodiment of FIG. 20, metallization layer M1 can include a conductive material formed of copper (Cu) and metallization level M2 can include a metal formation formed of aluminum (Al). Metallization level M2 including aluminum conductive metal can define a contact pad for accommodation of bonded wires or low temperature and high temperature device measurements.

[0113] Metallization level M2 as shown in FIG. 20 like metallization level M1 can be formed by a single layer damascene process wherein there is provided single-level patterning, filling, and planarization of conductive metallization material.

[0114] An alternative metallization damascene process is set forth in reference to FIG. 20, although not shown. If

intermediate via connections are required between metallization level M1 and metallization level M2 as a consequence of circuit design, a dual damascene metallization process may be employed where the vias and metal wire trenches for accommodating conductive material formations 742 and conductive material formations 752 are formed first through sequential patterning and etching, and then filled and planarized in a common deposition (e.g., sputter), plating, and polishing process. Via connections may be required if for example metallization level M2 wire levels need to cross metallization level M1 wire levels without electrical contact. Dual damascene processes shorten the process flow and reduce complexity compared to two separate single damascene applications.

[0115] It was observed that commercially available deposition conditions that form waveguiding core materials (e.g., silicon or silicon nitride) require processing temperatures of greater than about 500 degrees Celsius. As an example, disilane is commonly used to deposit amorphous silicon at 550 degrees Celsius, and LPCVD silicon nitride is grown using substrate temperatures of greater than about 750 degrees Celsius. As the temperature of commercially available processing steps to complete the metal wiring formations on wafers can be limited to 400 degrees Celsius for the case of copper, traditional waveguiding core materials are not capable of integration into the wiring level modules. However, methods as set forth herein allow for significantly reduced substrate temperatures, thus enabling the integration of photonic elements in the back-end modules. For example, plasma enhancement during nitride CVD can reduce the processing temperature to a temperature in the range of 400 degrees Celsius. Similar temperatures can also be obtained using new long-chain precursors (such as pentasilane) during amorphous silicon CVD.

[0116] In one embodiment, with use of fabrication methods as are set forth herein the structure 10 can include photonic elements embedded in the back-end-of-the-line (BEOL) stack, after metallization is present on the wafer. Referring to FIG. 21, each via or wire metallization level such as the shown M1 and V1, can include waveguiding features 8000 (e.g., waveguides at an elevation in common with a bottom elevation of a wiring level, e.g., elevation 8001 or elevation 8003) or embedded within the bulk of a wiring level (e.g., at elevation 8002 or elevation 8004). Materials for waveguiding features embedded in BEOL assemblies can be formed, e.g., of silicon nitride or silicon. Regarding metallization layer V1, metallization layer V1 can be a vias metallization layer and can include conductive material formations 762 extending through layer 170, layer 153, and layer 152. Conductive material formations 762 can be in contact with conductive material formations 742. Regarding conductive material formations herein, e.g., formations 712, 722, 742, 752, 762, conductive material formations 712, 722, 742, 752, 762 herein can be formed, e.g., of semiconductor-compatible metallization materials. In one embodiment, conductive material formations 712, 722, 742, 752, 762 herein each can be formed of a metallization material that is adapted to reflect light at wavelengths within a communication band of wavelengths of from about 1.3 μm to about 1.55 μm . In one embodiment, conductive material formations 712, 722, 742, 752, 762 herein each can be formed of a metallization material that is adapted to reflect light at wavelengths within a band of wavelengths of from about 900 nm to about 1600 nm.

[0117] In one embodiment, fabrication of a photonic structure **10** as set forth in FIG. **21** having photonic elements embedded in BEOL assembly can include the removal of films of high refractive index (e.g., silicon nitride or nitrogen-rich SiC) from areas **8000** in the optical vicinity (typically from about 1 μm to about 10 μm) surrounding said embedded photonic elements. Furthermore, by way of altering the lithography mask design, fill and other shapes of the respective wiring levels can be eliminated from areas **8000** in the optical vicinity (typically from about 1 μm to about 10 μm) surrounding said embedded photonic elements.

[0118] In one embodiment, photonic structure **10** that includes photonic elements embedded in BEOL assembly can be subjected during the fabrication process to low-temperature line-edge roughness mitigation treatments, such as high-pressure oxidation followed by wet chemical oxide etching.

[0119] In one embodiment as depicted schematically in FIG. **22**, photonic structure **10** can include photonic elements embedded in assemblies created by wafer-level or chip-level bonding, where full wafers or individual chips can be aligned and bonded to handle wafers. Handle wafer A and bonding wafer B can each include one or more photonic layers (e.g., waveguiding layer **210** waveguiding layer **310** waveguiding layer **320** and waveguiding layer **410** as shown in FIG. **22**) distributed over FEOL and BEOL modules, and may be of common or dissimilar functionality. Regarding waveguiding layer **310** waveguiding layer **310** can be a silicon nitride waveguiding layer. At area **902** waveguiding layer **310** can be patterned into a plurality of waveguides. At area **904** waveguiding layer **310** can remain unpatterned. At area **904** common waveguiding layer **310** formed at an elevation higher than wiring assembly **906** can be aligned to the one or more conductive material formation defining wiring assembly **906** and function as a protect layer for protecting wiring assembly **906** which can include one or more copper conductive material formation. Waveguiding layer **310** at area **904** can inhibit diffusion of wiring assembly **906**. Waveguiding layer **310** at area **904** can function as an etch stop layer for protection of one or more conductive material formation of wiring assembly **906**. Wiring assembly **906** can be configured in accordance with any of the wiring assemblies set forth herein, e.g. in relation to FIGS. **19-21**, and in one embodiment can be coupled to a defined photo-detector structure as set forth in reference to FIGS. **19-21**. Wiring assembly **906** can include one or more wiring level e.g. M1, M2, V1 as set forth herein. In one embodiment, structure **10** that includes layers of photonic elements embedded in the bonded wafer assembly can host waveguiding features that can be waveguiding layers formed of silicon nitride or silicon.

[0120] In another embodiment, photonic structure **10** that includes layers of photonic elements embedded in the bonded wafer assembly shown in the example of FIG. **22** can include waveguiding features defined by waveguiding layers formed of low-temperature silicon nitride (PECVD) or silicon (using long-chain precursors) on either wafer where temperatures were limited to those of metal processing. In one embodiment, photonic structure **10** that includes layers of photonic elements embedded in the bonded wafer assembly can include silicon nitride photonic elements, e.g., defined by waveguiding layer **310** formed of silicon nitride near the bonding interface if optical coupling from

handle to bonded portion is desired. Mode confinement in silicon nitride can be reduced, thus allowing relaxed bonding alignment and cladding layer thickness control compared to a silicon waveguide core.

[0121] In one embodiment, fabrication of a photonic structure **10** having photonic elements embedded in the bonded assembly can include the removal of films of high refractive index (e.g., silicon nitride or nitrogen-rich SiC) from areas in the optical vicinity (typically from about 1 μm to about 10 μm) surrounding said embedded photonic elements, on both the handle and bonding portion. Furthermore, by way of altering the lithography mask design, fill and other shapes of the respective wiring levels are eliminated from areas in the optical vicinity (typically from about 1 μm to about 10 μm) surrounding said embedded photonic elements, on both the handle and bonding portion.

[0122] In one embodiment, photonic structure **10** that includes photonic elements embedded in a bonded assembly can be subjected during the fabrication process to low-temperature line-edge roughness mitigation treatments, such as high-pressure oxidation followed by wet chemical oxide etching.

[0123] A small sample of methods apparatus and systems herein include the following.

[0124] A1. A method of fabricating a photonic structure comprising: forming a stack of hardmask material over a layer of waveguiding material; depositing a stack of organic lithography material over the stack of hardmask materials; and patterning the stack of organic lithography material, wherein the patterning includes stopping at the stack of hardmask material. A2. The method of A1, wherein the method includes patterning waveguide features in the layer of waveguiding material using the stack of organic lithography material. A3. The method of A1, wherein the patterning includes using reactive ion etching and wherein the method includes cleaning formed residue formed by the reactive ion etching. A4. The method of A1, wherein the patterning includes using reactive ion etching, wherein the method includes cleaning residue formed by the reactive ion etching, wherein the method includes patterning waveguide features in the layer of waveguiding material using the stack of organic material, and wherein the cleaning is performed subsequent to the patterning.

[0125] B1. A photonic structure comprising: a plurality of photonic layers formed of a waveguiding material; wherein the plurality of photonic layers includes a first photonic layer and a second photonic layer; and one or more waveguide defined by each of the first photonic layer and the second photonic layer. B2. The photonic structure of B1, wherein the first photonic layer and the second photonic layer are formed of different waveguiding materials. B3. The photonic structure of B2, wherein each of the first photonic layer and the second photonic layer is formed of a waveguiding material selected from the group consisting of crystalline silicon, poly-crystalline silicon, amorphous silicon, and silicon nitride. B4. The photonic structure of B1, wherein the first photonic layer and the second photonic layer are formed of a common waveguiding material. B5. The photonic structure of B1, wherein each of the first photonic layer and the second photonic layer is formed of a waveguiding material selected from the group consisting of crystalline silicon, poly-crystalline silicon, amorphous silicon, and silicon nitride. B6. The photonic structure of B1, wherein the first photonic layer and the second photonic layer are formed

of different waveguiding material and are formed at different elevations. B7. The photonic structure of B1, wherein the first photonic layer and the second photonic layer are formed of different waveguiding material and wherein the first photonic layer and the second photonic layer are at a common elevation. B8. The photonic structure of B7, wherein a bottom elevation of the first photonic layer and a bottom elevation of the second photonic layer are formed at a common elevation. B9. The photonic structure of B1, wherein the photonic structure includes an inter-level dielectric layer separating the first photonic layer and the second photonic layer. B10. The photonic structure of B1, wherein the one or more waveguide is of a geometry selected from the group consisting of a rectangular geometry and a ridge geometry. B11. The photonic structure of B1, wherein the first photonic layer is at an elevation below the second photonic layer. B12. The photonic structure of B1, wherein the first photonic layer is at an elevation above the second photonic layer. B13. The photonic structure of B1, wherein the photonic structure is further characterized by a feature selected from the group consisting of: (a) first and second waveguides of different minimum thicknesses are defined in the first photonic layer, (b) a first waveguide having a first minimum thicknesses is defined by the first photonic layer and a second waveguide having a second minimum thickness is defined by the second photonic layer; (c) waveguides of different geometries are defined by the first photonic layer; (d) a first waveguide of a first geometry is defined by the first photonic layer and a second waveguide of a second geometry is defined by the second photonic layer. B14. The photonic structure of B1, wherein the plurality of photonic layers includes the first photonic layer, the second photonic layer, a third photonic layer and fourth photonic layer. B15. The photonic structure of B1, wherein the plurality of photonic layers includes the first photonic layer, the second photonic layer, a third photonic layer and fourth photonic layers, and wherein each of the first photonic layer, the second photonic layer, the third photonic layer and the fourth photonic layer is formed at a different elevation.

[0126] C1. A photonic structure comprising: a photonic layer and one or more waveguide defined by the photonic layer, wherein the photonic structure includes a feature selected from the group consisting of (a) first and second waveguides of different minimum thicknesses are defined in the photonic layer and (b) waveguides of different geometries are defined by the photonic layer. C2. The photonic structure of C1, wherein the photonic layer is formed of a waveguiding material selected from the group consisting of crystalline silicon, poly-crystalline silicon, amorphous silicon, and silicon nitride.

[0127] D1. A method of fabricating a photonic structure comprising: patterning a first waveguide in a first photonic layer, the first photonic layer formed of a first waveguiding material; and forming a dielectric layer about the first waveguide. D2. The method of D1, wherein dielectric material of the dielectric layer includes a plasma-enhanced deposited oxide. D3. The method of D1, wherein the forming includes using plasma enhanced chemical vapor deposition (PECVD). D4. The method of D1, wherein the forming includes forming plasma-enhanced oxide material over the first photonic layer so that the plasma enhanced oxide material preferentially deposits on horizontal surfaces with suppressed deposition rates on vertical surface proximate feature edges, resulting in an overall non-conformal film

topography. D5. The method of D1, wherein the forming includes applying process conditions for deposition of non-conformal oxide material deposition in a manner to provide void-minimized filling of minimum feature size gaps. D6. The method of D1, wherein the method includes planarizing the dielectric layer to provide processing planarity for further layers. D7. The method of D1, wherein the method includes forming a second dielectric layer above the dielectric layer to provide corrected dielectric separation distance to one or more additional waveguiding layer.

[0128] E1. A method of fabricating a photonic structure comprising: patterning a first waveguide in a first layer, the first layer formed of a first waveguiding material. E2. The method of E1, wherein processing of waveguiding layers and layers above the one or more waveguiding levels include: removal of silicon nitride material in an optical vicinity of waveguides and other photonic elements using lithography, etching, and cleaning; removal of nitrogen-rich silicon carbide material in the optical vicinity of waveguides and other photonic elements using lithography, etching, and cleaning; omission in mask design of filling features in each waveguiding layer; omission in mask design of filling features in each metal wiring layer; omission in mask design of filling features in each connecting metal via layer. E3. The method of E1, wherein the first waveguiding material is silicon, and wherein the method includes performing line edge roughness treatment of the first waveguide using H₂ annealing. E4. The method of E3, wherein the H₂ annealing is performed at a temperature of between about 700 degrees Celsius and about 950 degrees Celsius.

[0129] F1. A method of fabricating a photonic structure comprising: depositing a layer formed of nitride waveguiding material; and patterning the layer formed of nitride waveguiding material to define a waveguide, wherein the depositing includes using plasma-enhanced chemical vapor deposition. F2. The method of F1, wherein the method includes performing treatment of the layer formed of nitride waveguiding material for correction of one or more or contamination, inclusions, voids, or non-stoichiometries, wherein the treatment is selected from the group consisting of thermal annealing or exposure to radiation. F3. The method of F1, wherein the method further includes planarizing and smoothing the layer formed of nitride waveguiding material. F4. The method of F1, further comprising depositing a non-conformal high-aspect-ratio gap-filling dielectric material over the waveguide. F5. The method of F, wherein the depositing a layer includes using PECVD.

[0130] G1. A method of fabricating a photodetector structure comprising: forming dielectric material over a silicon waveguide; etching a trench in the dielectric material extending to the silicon waveguide; epitaxially growing germanium within the trench; annealing germanium formed by the epitaxially growing; repeating the epitaxially growing and the annealing until the germanium overfills the trench; planarizing an overfill portion of the germanium; and creating top and bottom contacts using ion implantation and metallization. G2. The method of G1, wherein the epitaxially growing is performed so that germanium is formed on the silicon waveguide. G3. The method of G1, wherein the epitaxially growing is performed so that the photodetector structure is absent a low-temperature SiGe or Ge buffer structure adjacent to the silicon waveguide. G5. The method of G1, wherein the epitaxially growing of germanium is performed without use of a doping gas so that intrinsic

germanium is formed by the epitaxially growing. G6. The method of G1, wherein the epitaxially growing of germanium is performed using a dopant precursor so that in-situ doped germanium is formed by the epitaxially growing. G7. The method of G1, wherein the epitaxially growing includes performing epitaxial growing at a temperature in the range of from about 550 to about 850 degree Celsius. G8. The method of G1, wherein the epitaxially growing includes performing epitaxial growing at a temperature in the range of from about 550 to about 850 degree Celsius and wherein the annealing includes annealing at a temperature of between about 650 degrees Celsius to about 850 degrees Celsius. G9. The method of G1, wherein the epitaxially growing includes performing epitaxial growing at a temperature in the range of from about 550 to about 850 degree Celsius at a pressure in the range of from about 10 Torr to about 300 Torr using germane (GeH_4) and H_2 as a precursor and carrier gas, and wherein the annealing includes annealing at a temperature of between about 650 degrees Celsius to about 850 degrees Celsius at a pressure of between about 100 Torr to about 600 Torr. G10. The method of G1, wherein the growing is preceded by an ex-situ wet-chemical and an in-situ dry cleaning process for removal of organic and metallic contamination and native oxide. G11. The method of G1, wherein the growing is further preceded by an in-situ thermal treatment in a reducing H_2 -environment for removal of sub-stoichiometric surface silicon oxide. G12. The method of G1, wherein the method includes performing a shallow top contact ion implantation and depositing a capping oxide. G13. The method of G1, wherein the method includes forming a reduced area ion implantation region spaced apart from an oxide trench. G14. The method of G1, wherein the method includes forming a reduced area shallow top ion implantation spaced apart from an oxide trench so that there is defined spacing distance between a perimeter of the germanium and a perimeter of the ion implantation. G15. The method of G1, wherein the method includes forming a reduced area shallow top implantation region spaced apart from an oxide trench by a spacing distance equal to or greater than a threshold distance. G16. The method of G1, wherein the method includes forming a reduced area top metal contact that is fully contained in a top ion implant region.

[0131] H1. A photonic structure comprising: a waveguide; a germanium formation formed on the waveguide; a first ion implantation region and a second ion implantation region, the second ion implantation region being of opposite polarity to the first ion implantation region to form a p-i-n or n-i-p formation. H2. The photonic structure of H1, wherein the photonic structure is absent of a low-temperature SiGe or Ge buffer between the waveguide and the germanium formation. H3. The photonic structure of H1, wherein the first ion implantation region is formed in the germanium formation. H4. The photonic structure of H1, wherein the second ion implantation region is formed in the waveguide. H5. The photonic structure of H1, wherein the second ion implantation region is formed in the waveguide and in the germanium formation.

[0132] I1. A photonic structure comprising: a waveguide; dielectric material formed over the waveguide; a trench formed in the dielectric material extending to the waveguide; a germanium formation formed in the trench; and an ion implantation region formed in an area of the germanium formation so that the ion implantation region is spaced from

the trench by a spacing distance equal to or greater than a threshold distance. I2. The photonic structure of I1, wherein an entire perimeter of the ion implantation region is spaced from the trench by a spacing distance equal to or greater than a threshold distance. I3. The photonic structure of I1, wherein the threshold distance is 750 nm. I4. The photonic structure of I1, further comprising a contact formed on the ion implantation region in an area of the ion implantation region so that the contact is spaced from a perimeter of the ion implantation region by a spacing distance that is equal to or greater than a threshold distance. I5. The photonic structure of I1, further comprising a contact formed on the ion implantation region in an area of the ion implantation region so that an entire perimeter of the contact is spaced from a perimeter of the ion implantation region by a spacing distance that is equal to or greater than a threshold distance.

[0133] J1. A photonic structure comprising: a waveguide having an ion implantation region; a germanium formation adapted to receive light transmitted by the waveguide; an oppositely doped ion implantation region formed on the germanium formation; a silicide formation formed on the ion implantation region of the waveguide; a conductive material formation formed on the silicide formation; and a conductive material formation formed on the germanium formation. J2. The photonic structure of J1, wherein the conductive material formation formed on the germanium formation is a germanide-free (refractory) conductive material formation. J3. The photonic structure of J1, comprising dielectric material formed over the waveguide, and a trench formed in the dielectric material, wherein the silicide formation and the conductive material formation are formed in the trench. J4. The photonic structure of J1, comprising dielectric material formed over the germanium formation, and a trench formed in the dielectric material, wherein the conductive material formation is formed in the trench.

[0134] K1. A photonic structure comprising: a wiring level having a conductive material formation that defines a wiring assembly, wherein the conductive material formation is formed of a metallization material; and a waveguiding layer; wherein the waveguiding layer is formed at an elevation of the photonic structure that is in common with or higher than an elevation of the wiring level. K2. The photonic structure of K1, wherein the conductive material formation is formed of a metallization material that is adapted to reflect light at wavelengths within a communication band of wavelengths of from about 1.3 μm to about 1.55 μm . K3. The photonic structure of K1, wherein the conductive material formation is formed of a metallization material that is adapted to reflect light at wavelengths within a band of wavelengths of from about 900 nm to about 1600 nm. K4. The photonic structure of K1, wherein the waveguiding layer is formed of silicon nitride deposited using plasma enhanced chemical vapor deposition. K5. The photonic structure of K1, wherein the waveguiding layer is formed at an elevation higher than an elevation of the wiring level. K6. The photonic structure of K1, wherein the waveguiding layer is formed at an elevation higher than an elevation of the wiring level and includes a first patterned section patterned to define one or more waveguide and a second section aligned to the conductive material formation. K7. The photonic structure of K1, wherein the waveguiding layer is formed at an elevation higher than an elevation of the wiring level and includes a first patterned section pat-

terned to define one or more waveguide and a second section aligned to the conductive material formation so that the second section functions as a protect layer for the conductive material formation.

[0135] L1. A method of fabricating a photodetector structure comprising: forming dielectric material over silicon; etching a trench in the dielectric material extending to the silicon; epitaxially growing germanium within the trench; annealing germanium formed by the epitaxially growing; repeating the epitaxially growing and the annealing until the germanium overfills the trench; planarizing an overfill portion of the germanium; and creating top and bottom contacts using doping and metallization. L2. The method of L1, wherein the epitaxially growing is performed so that germanium is formed on the silicon. L3. The method of L1, wherein the epitaxially growing is performed so that the photodetector structure is absent a low-temperature SiGe or Ge buffer structure adjacent to the silicon. L4. The method of L1, wherein the epitaxially growing of germanium is performed without use of a doping gas so that intrinsic germanium is formed by the epitaxially growing. L5. The method of L1, wherein the epitaxially growing of germanium is performed using a dopant precursor so that in-situ doped germanium is formed by the epitaxially growing. L6. The method of L1, wherein the epitaxially growing includes performing epitaxial growing at a temperature in the range of from about 550 to about 850 degree Celsius. L7. The method of L1, wherein the epitaxially growing includes performing epitaxial growing at a temperature in the range of from about 550 to about 850 degree Celsius and wherein the annealing includes annealing at a temperature of between about 650 degrees Celsius to about 850 degrees Celsius. L8. The method of L1, wherein the epitaxially growing includes performing epitaxial growing at a temperature in the range of from about 550 to about 850 degree Celsius at a pressure in the range of from about 10 Torr to about 300 Torr using germane (GeH₄) and H₂ as a precursor and carrier gas, and wherein the annealing includes annealing at a temperature of between about 650 degrees Celsius to about 850 degrees Celsius at a pressure of between about 100 Torr to about 600 Torr. L9. The method of L1, wherein the growing is preceded by an ex-situ wet-chemical and an in-situ dry cleaning process for removal of organic and metallic contamination and native oxide. L10. The method of L1, wherein the growing is further preceded by an in-situ thermal treatment in a reducing H₂-environment for removal of sub-stoichiometric surface silicon oxide. L11. The method of L1, wherein the method includes performing a shallow top contact doping region and depositing a capping oxide. L12. The method of L1, wherein the method includes forming a reduced area doping region spaced apart from an oxide trench. L13. The method of L1, wherein the method includes forming a reduced area shallow top doping region spaced apart from an oxide trench so that there is defined spacing distance between a perimeter of the germanium and a perimeter of a doping region. L14. The method of L1, wherein the method includes forming a reduced area shallow top doping region spaced apart from an oxide trench by a spacing distance equal to or greater than a threshold distance. L15. The method of L1, wherein the method includes forming a reduced area top metal contact that is fully contained in a top doping region. L16. The method of L1,

wherein the photonic structure is absent of a low-temperature SiGe or Ge buffer between the silicon and the germanium formation.

[0136] M1. A photonic structure comprising: dielectric material formed over silicon; a trench formed in the dielectric material extending to the silicon; a germanium formation formed in the trench; and a doping region formed in an area of the germanium formation so that the doping region is spaced from the trench by a spacing distance equal to or greater than a threshold distance. M2. The photonic structure of M1, wherein an entire perimeter of the doping region is spaced from the trench by a spacing distance equal to or greater than a threshold distance. M3. The photonic structure of M1, wherein the threshold distance is selected from the group consisting of (a) 200 nm to 1000 nm and (b) 750 nm. M4. The photonic structure of M1, wherein the threshold distance is 750 nm. M5. The photonic structure of M1, further comprising a contact formed on the doping region in an area of the doping region so that the contact is spaced from a perimeter of the doping region by a spacing distance that is equal to or greater than a threshold distance. M6. The photonic structure of M1, further comprising a contact formed on the doping region in an area of the doping region so that an entire perimeter of the contact is spaced from a perimeter of the doping region by a spacing distance that is equal to or greater than a threshold distance.

[0137] N1. A photonic structure comprising: silicon having a doping region; a germanium formation adapted to receive light transmitted by the silicon; an oppositely doped doping region formed on the germanium formation; a silicide formation formed on the doping region of the silicon; a conductive material formation formed on the silicide formation; and a conductive material formation formed on the germanium formation. N2. The photonic structure of N1, wherein the conductive material formation formed on the germanium formation is a germanide-free (refractory) conductive material formation.

[0138] O1. A method of fabricating a photonic structure comprising: depositing a layer formed of nitride waveguiding material; and patterning the layer formed of nitride waveguiding material to define photonic features, wherein the depositing includes using plasma-enhanced chemical vapor deposition. O2. The method of O1, wherein the method includes performing treatment of the layer formed of nitride waveguiding material for correction of one or more or contamination, inclusions, voids, or non-stoichiometries, wherein the treatment is selected from the group consisting of thermal annealing and exposure to radiation. O3. The method of O1, wherein the method further includes planarizing and smoothing the layer formed of nitride waveguiding material. O4. The method of O1, further comprising depositing a non-conformal high-aspect-ratio gap-filling dielectric material over the waveguide.

[0139] P1. A method comprising: depositing a metal within a trench, the trench having a bottom formed of silicon and sidewalls formed of dielectric material; performing silicide formation annealing so that metal reacts with the silicon to form a silicide formation at the bottom of the trench; performing transformation stage annealing so that the silicide formation is transformed into a low resistivity phase. P2. The method of P1, wherein the depositing a metal results in unreacted metal being formed on the sidewalls, and wherein the method includes forming a capping layer over the unreacted metal prior to the performing silicide

formation annealing. P3. The method of P1, wherein the depositing a metal results in unreacted metal being formed on the sidewalls, wherein the method includes forming a capping layer over the unreacted metal prior to the performing silicide formation annealing, and wherein the method includes removing the capping layer and the unreacted metal prior to the performing transformation stage annealing. P4. The method of P1, wherein the transformation stage annealing is performed at a higher annealing temperature than the silicide formation annealing. P5. The method of P1, wherein the metal is selected from the group consisting of nickel and nickel platinum. P6. The method of P1, wherein the depositing a metal is followed by a second metal deposition overfilling the trench so that the second metal has a thickness at a top of the trench that is multiple times a desired thickness at a bottom of the trench. P7. The method of P1, wherein the depositing a metal is followed by a second metal deposition overfilling the trench so that the second metal has a thickness at a top of the trench that is more than three times a desired thickness at a bottom of the trench. P8. The method of P1, wherein the method of depositing a second metal includes forming copper within the trench subsequent to formation of the silicide formation (first metal).

[0140] Q1. A method of forming a photonic structure comprising: forming a photodetector having a bottom and top contact; forming a dielectric layer defining a trench over the top contact; forming an aluminum metallization layer within the trench, the aluminum metallization layer being in communication with the top contact. Q2. The method of Q1, wherein the method includes subjecting the aluminum metallization layer to processing so that the aluminum metallization layer defines a termination layer. Q3. The method of Q1, wherein the method includes using a damascene process to form the aluminum metallization layer, and wherein the method is performed so that the aluminum metallization layer defines an aluminum termination over a copper conductive material formation. Q4. The method of Q1, wherein the forming an aluminum metallization layer includes depositing aluminum using a process selected from the group consisting of physical vapor deposition (PVD), chemical vapor deposition (CVD) and evaporation. Q5. The method of Q1, wherein the method includes performing a low temperature anneal to densify, reflow, or recrystallize the aluminum metallization layer. Q6. The method of Q1, wherein the method includes performing a moderate temperature aluminum metallization compatible with existing (Cu) metallization formations. Q7. The method of Q1, wherein the method includes subjecting the aluminum metallization layer to processing to define a contact pad. Q8. The method of Q1, wherein the method includes planarizing the aluminum metallization layer so that the aluminum metallization layer defines a flat wiring assembly. Q9. The method of Q1, wherein the method includes performing a dual-patterning and single fill/planarization process where the aluminum metallization layer simultaneously fills the trench and a via below the trench, and wherein the method includes planarizing the aluminum metallization layer.

[0141] R1. A method of fabricating a photonic structure comprising: forming a stack of hardmask material over a layer of waveguiding material; depositing a stack of organic lithography material over the stack of hardmask materials; and patterning the stack of organic lithography material, wherein the patterning includes stopping at the stack of hardmask material. R2. The method of R1, wherein the stack

of hardmask material includes silicon dioxide. R3. The method of R1, wherein the method includes patterning photonic features (in the layer of waveguiding material using the stack of organic lithography material. R4. The method of R1, wherein the patterning includes using reactive ion etching and wherein the method includes cleaning residue formed by the reactive ion etching. R5. The method of R1, wherein the patterning includes using reactive ion etching, wherein the method includes cleaning residue formed by the reactive ion etching, wherein the method includes patterning photonic features in the layer of waveguiding material using the stack of organic lithography material, and wherein the cleaning is performed subsequent to the patterning.

[0142] S1. A method of fabricating a photonic structure comprising: patterning a first set of photonic features in a first photonic layer, the first photonic layer formed of a first waveguiding material; and forming a dielectric layer about the first set of photonic features, wherein dielectric material of the dielectric layer includes a plasma-enhanced oxide. S2. The method of S1, wherein the forming includes using plasma enhanced chemical vapor deposition (PECVD), and wherein the method includes forming a second dielectric layer above the dielectric layer to provide corrected dielectric separation distance to one or more additional waveguiding layer. S3. The method of S1, wherein the forming includes using plasma enhanced chemical vapor deposition (PECVD). S4. The method of S1, wherein the forming includes forming plasma-enhanced oxide material over the first photonic layer so that the plasma-enhanced oxide material preferentially deposits on horizontal surfaces with suppressed deposition rates on vertical surface proximate feature edges, resulting in an overall non-conformal film topography. S5. The method of S1, wherein the forming includes applying process conditions for deposition of non-conformal oxide material deposition in a manner to provide void-minimized filling of minimum feature size gaps. S6. The method of S1, wherein the method includes planarizing the dielectric layer to provide processing planarity for further layers. S7. The method of S1, wherein the method includes forming a second dielectric layer above the dielectric layer to provide corrected dielectric separation distance to one or more additional waveguiding layer.

[0143] T1. A method of fabricating a photonic structure comprising: forming a plurality of photonic layers; wherein the plurality of photonic layers includes a first photonic layer and a second photonic layer; and patterning the first photonic layer and the second photonic layer so that each of the first photonic layer and the second photonic layer defines one or more set of photonic features. T2. The method of T1, wherein the first photonic layer and the second photonic layer are formed of different waveguiding materials. T3. The method of T2, wherein each of the first photonic layer and the second photonic layer is formed of a waveguiding material selected from the group consisting of crystalline silicon, poly-crystalline silicon, amorphous silicon, silicon nitride, and silicon oxynitride. T4. The method of T1, wherein each of the first photonic layer and the second photonic layer is formed of a waveguiding material selected from the group consisting of crystalline silicon, poly-crystalline silicon, amorphous silicon, silicon nitride, and silicon oxynitride. T5. The method of T1, wherein the first photonic layer and the second photonic layer are formed of different waveguiding material and are formed at different elevations.

T6. The method of T1, wherein the first photonic layer and the second photonic layer are formed of different waveguiding material and wherein the first photonic layer and the second photonic layer are at a common elevation. T7. The method of T1, wherein a bottom elevation of the first photonic layer and a bottom elevation of the second photonic layer are formed at a common elevation. T8. The method of T1, wherein the first photonic layer is at an elevation below the second photonic layer. T9. The method of T1, wherein the plurality of photonic layers includes the first photonic layer, the second photonic layer, a third photonic layer and a fourth photonic layer. T10. The method of T1, wherein the plurality of photonic layers includes the first photonic layer, the second photonic layer, a third photonic layer and fourth photonic layers, and wherein each of the first photonic layer, the second photonic layer, the third photonic layer and the fourth photonic layer is formed at a different elevation.

[0144] U1. A method of fabricating a photonic structure comprising: forming a photonic layer; and patterning the photonic layer to define one or more set of photonic features, wherein the method is characterized by one or more of the following selected from the group consisting of: (a) the method is performed so that first and second sets of photonic features of different minimum thicknesses are defined in the photonic layer and (b) the method is performed so that sets of photonic features of different geometries are defined by the photonic layer. U2. The method of U1, wherein the photonic layer is formed of a waveguiding material selected from the group consisting of, poly-crystalline silicon, amorphous silicon, silicon nitride, and silicon oxynitride.

[0145] V1. A photonic structure comprising: a wiring level having a conductive material formation that defines a wiring assembly, wherein the conductive material formation is formed of a metallization material; and a waveguiding layer patterned to define photonic features; wherein the waveguiding layer is formed at an elevation of the photonic structure that is in common with or higher than an elevation of the wiring level. V2. The photonic structure of V1, wherein the conductive material formation is formed of a metallization material that is adapted to reflect light at wavelengths within a communication band of wavelengths of from about 1.3 m to about 1.55 m. V3. The photonic structure of V1, wherein the conductive material formation is formed of a metallization material that is adapted to reflect light at wavelengths within a band of wavelengths of from about 900 nm to about 1600 nm. V4. The photonic structure of V1, wherein the waveguiding layer is formed of silicon nitride. V5. The photonic structure of V1, wherein the waveguiding layer is formed of a material selected from the group consisting of amorphous silicon and polysilicon. V6. The photonic structure of V1, wherein the waveguiding layer is formed of silicon nitride deposited using plasma enhanced chemical vapor deposition. V7. The photonic structure of V1, wherein the waveguiding layer is formed at an elevation higher than an elevation of the wiring level. V8. The photonic structure of V1, wherein the waveguiding layer is formed at an elevation higher than an elevation of the wiring level and includes a first patterned section patterned to define one or more set of photonic features and a second section aligned to the conductive material formation. V9. The photonic structure of V1, wherein the waveguiding layer is formed at an elevation higher than an elevation of the wiring level and includes a first patterned section patterned to define one or

more set of photonic features and a second section aligned to the conductive material formation so that the second section functions as a protect layer for the conductive material formation.

[0146] W1. A photonic structure comprising: a first photonic feature; a second photonic feature; a third photonic feature; wherein the first photonic feature, the second photonic feature and the third photonic feature are at a common elevation; wherein one or more of the first second or third photonic feature is formed of a material other than monocrystalline silicon. W2. The photonic structure of W1, wherein each of the first photonic feature, second photonic feature and third photonic feature is formed of a material selected from the group consisting of monocrystalline silicon, polycrystalline silicon, amorphous silicon, silicon nitride, and silicon oxynitride.

[0147] The corresponding structures, materials, acts, and equivalents of all means or step plus function elements in the claims below, if any, are intended to include any structure, material, or act for performing the function in combination with other claimed elements as specifically claimed. The description of the present invention has been presented for purposes of illustration and description, but is not intended to be exhaustive or limited to the invention in the form disclosed. Many modifications and variations will be apparent to those of ordinary skill in the art without departing from the scope and spirit of the invention. The embodiment was chosen and described in order to best explain the principles of one or more aspects of the invention and the practical application, and to enable others of ordinary skill in the art to understand one or more aspects of the invention for various embodiments with various modifications as are suited to the particular use contemplated.

What is claimed is:

1. A method of fabricating a photodetector structure comprising:

forming dielectric material over a silicon waveguide;
etching a trench in the dielectric material extending to the silicon waveguide;
epitaxially growing germanium within the trench;
annealing germanium formed by the epitaxially growing;
repeating the epitaxially growing and the annealing;
depositing metal within a second trench, the second trench having a bottom defined by the silicon waveguide and a sidewall defined by the dielectric material;
performing silicide formation annealing so that the metal reacts with the silicon to form a silicide formation at a bottom of the trench; and
performing transformation stage annealing so that the silicide formation is transformed into a low resistivity phase.

2. The method of claim 1, wherein the depositing metal results in unreacted metal being formed on a sidewall of the second trench, and wherein the method includes forming a capping layer over the metal with the metal in an unreacted state prior to the performing silicide formation annealing.

3. The method of claim 1, wherein the depositing metal results in unreacted metal being formed on a sidewall of the second trench, wherein the method includes forming a capping layer over the metal with the metal in an unreacted state prior to the performing silicide formation annealing, and wherein the method includes removing the capping layer and the unreacted metal prior to the performing transformation stage annealing.

4. The method of claim 1, wherein the transformation stage annealing is performed at a higher annealing temperature than the silicide formation annealing.

5. The method of claim 1, wherein the metal is selected from the group consisting of nickel and nickel platinum.

6. The method of claim 1, wherein the depositing metal is followed by a second metal deposition overfilling the second trench so that the second metal has a thickness at a top of the second trench that is more than three times a thickness if the silicide formation at the bottom of the second trench.

7. The method of claim 1, wherein the method of depositing a second metal includes forming copper within the second trench subsequent to formation of the silicide formation (first metal).

8. A photonic structure comprising:

dielectric material formed over a silicon waveguide;

a trench formed in the dielectric material extending to the silicon waveguide;

a germanium formation formed in the trench, the germanium formation adapted to receive light transmitted by the silicon waveguide; and

a top doping region formed in an area of the germanium formation so that the top doping region is spaced from the trench by a spacing distance equal to or greater than a threshold distance.

9. The photonic structure of claim 8, wherein a bottom of the trench is defined by a top surface of the silicon waveguide.

10. The photonic structure of claim 8, wherein a sidewall of the trench at a bottom elevation of the sidewall is delimited by the dielectric material.

11. The photonic structure of claim 8, having a top contact formed on the top doping region, wherein the top contact is formed of a semiconductor compatible reflective metallization material.

12. The photonic structure of claim 8, having a top contact formed on the top doping region, wherein the top doping region throughout an area on which the top contact is formed defines a planar surface.

13. The photonic structure of claim 8, having a top contact formed on the top doping region, wherein the top doping region throughout an area on which the top contact is formed defines a planar surface, wherein the top contact formed on the doping region is formed in an area of the doping region so that an entire perimeter of the contact is spaced from a perimeter of the doping region by a spacing distance that is equal to or greater than a threshold distance.

14. A method comprising:

forming a photodetector having a bottom and top contact; forming a dielectric layer defining a trench, the trench having an elevation above an elevation of the top contact; and

forming an aluminum metallization layer within the trench, the aluminum metallization layer being in electrical communication with the top contact.

15. The method of claim 14, wherein the method includes subjecting the aluminum metallization layer to processing so that the aluminum metallization layer defines a termination layer.

16. The method of claim 14, wherein the forming a dielectric layer defining the trench is performed so that a bottom of the trench has an elevation above a top elevation of the top contact, wherein the method includes using a damascene process to form the aluminum metallization layer, and wherein the method is performed so that the aluminum metallization layer defines an aluminum termination over a copper conductive material formation.

17. The method of claim 14, wherein the method includes forming a waveguide so that the waveguide occupies elevations in common with elevations occupied by the aluminum metallization layer.

18. The method of claim 14, wherein the forming the aluminum metallization layer includes depositing aluminum using a process selected from the group consisting of physical vapor deposition (PVD), chemical vapor deposition (CVD) and evaporation, wherein the method includes performing a low temperature anneal to densify, reflow, or recrystallize the aluminum metallization layer, wherein the forming the aluminum metallization layer includes performing a moderate temperature aluminum metallization compatible with existing (Cu) metallization formations, and wherein the method includes subjecting the aluminum metallization layer to processing to define a contact pad.

19. The method of claim 14, wherein the method includes planarizing the aluminum metallization layer so that the aluminum metallization layer defines a flat wiring assembly.

20. The method of claim 14, wherein the method includes performing a dual-patterning and single fill/planarization process where the aluminum metallization layer simultaneously fills the trench and a via below the trench, and wherein the method includes planarizing the aluminum metallization layer.

* * * * *