



US 20200326764A1

(19) **United States**

(12) **Patent Application Publication**

Goergen et al.

(10) **Pub. No.: US 2020/0326764 A1**

(43) **Pub. Date: Oct. 15, 2020**

(54) **DELIVERY OF AC POWER WITH HIGHER POWER POE (POWER OVER ETHERNET) SYSTEMS**

(60) Provisional application No. 62/641,203, filed on Mar. 9, 2018.

(71) Applicant: **CISCO TECHNOLOGY, INC.**, San Jose, CA (US)

Publication Classification

(51) **Int. Cl.**
G06F 1/26 (2006.01)
H04L 12/40 (2006.01)
H04L 12/10 (2006.01)

(72) Inventors: **Joel Richard Goergen**, Soulsbyville, CA (US); **Chad M. Jones**, Doylestown, OH (US); **Dylan T. Walker**, Austin, TX (US)

(52) **U.S. Cl.**
CPC *G06F 1/266* (2013.01); *H04L 12/40032* (2013.01); *H04L 12/10* (2013.01); *H04L 12/40045* (2013.01)

(73) Assignee: **CISCO TECHNOLOGY, INC.**, San Jose, CA (US)

(57) **ABSTRACT**

(21) Appl. No.: **16/913,632**

In one embodiment, a method includes grouping a plurality of ports at power sourcing equipment receiving pulse power and transmitting power from the group of ports at the power sourcing equipment to a power interface module operable to combine the power and provide an AC (alternating current) outlet configured to provide AC power to one or more devices.

(22) Filed: **Jun. 26, 2020**

Related U.S. Application Data

(63) Continuation of application No. 16/040,745, filed on Jul. 20, 2018, now Pat. No. 10,732,688.

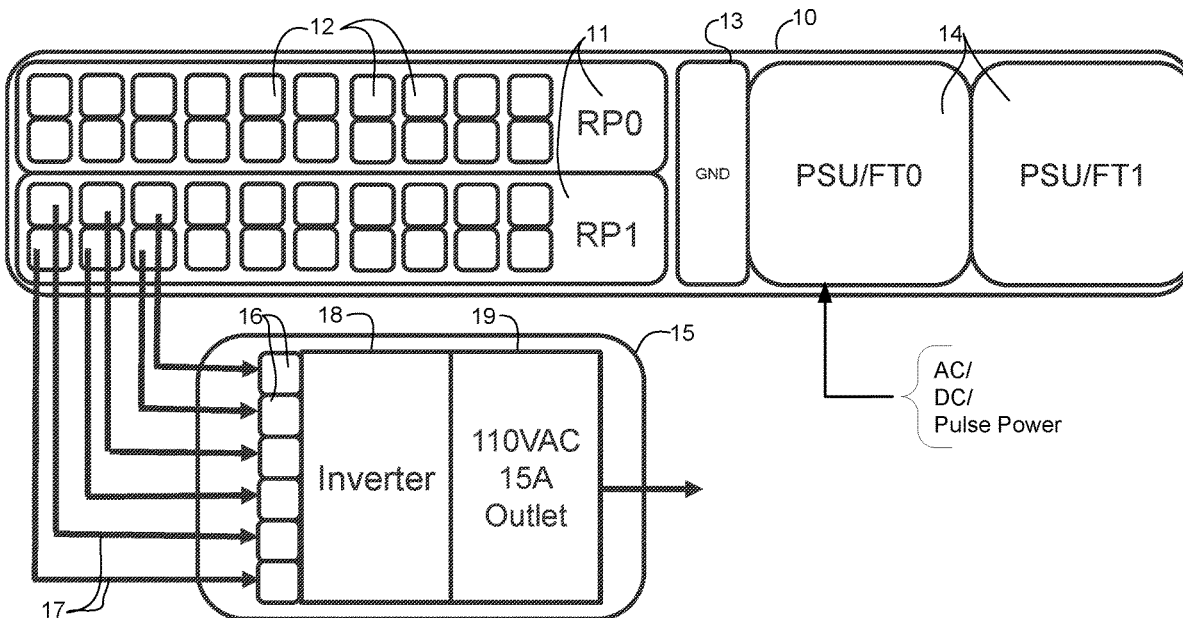

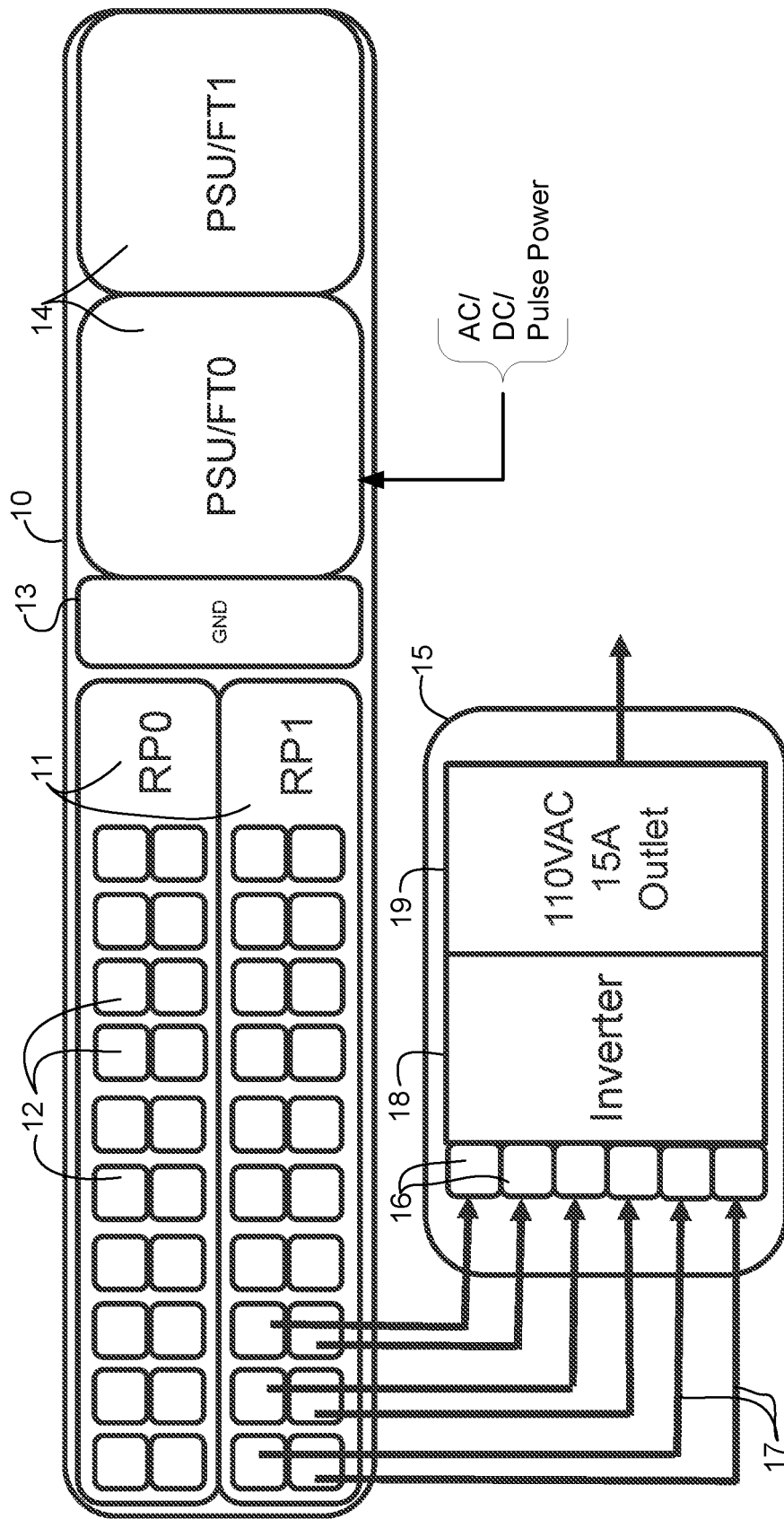

FIGURE 1

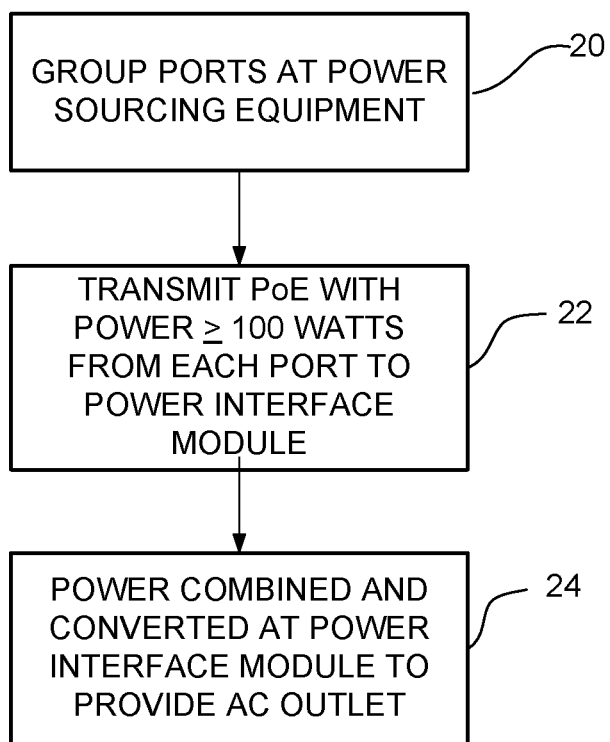

FIGURE 2

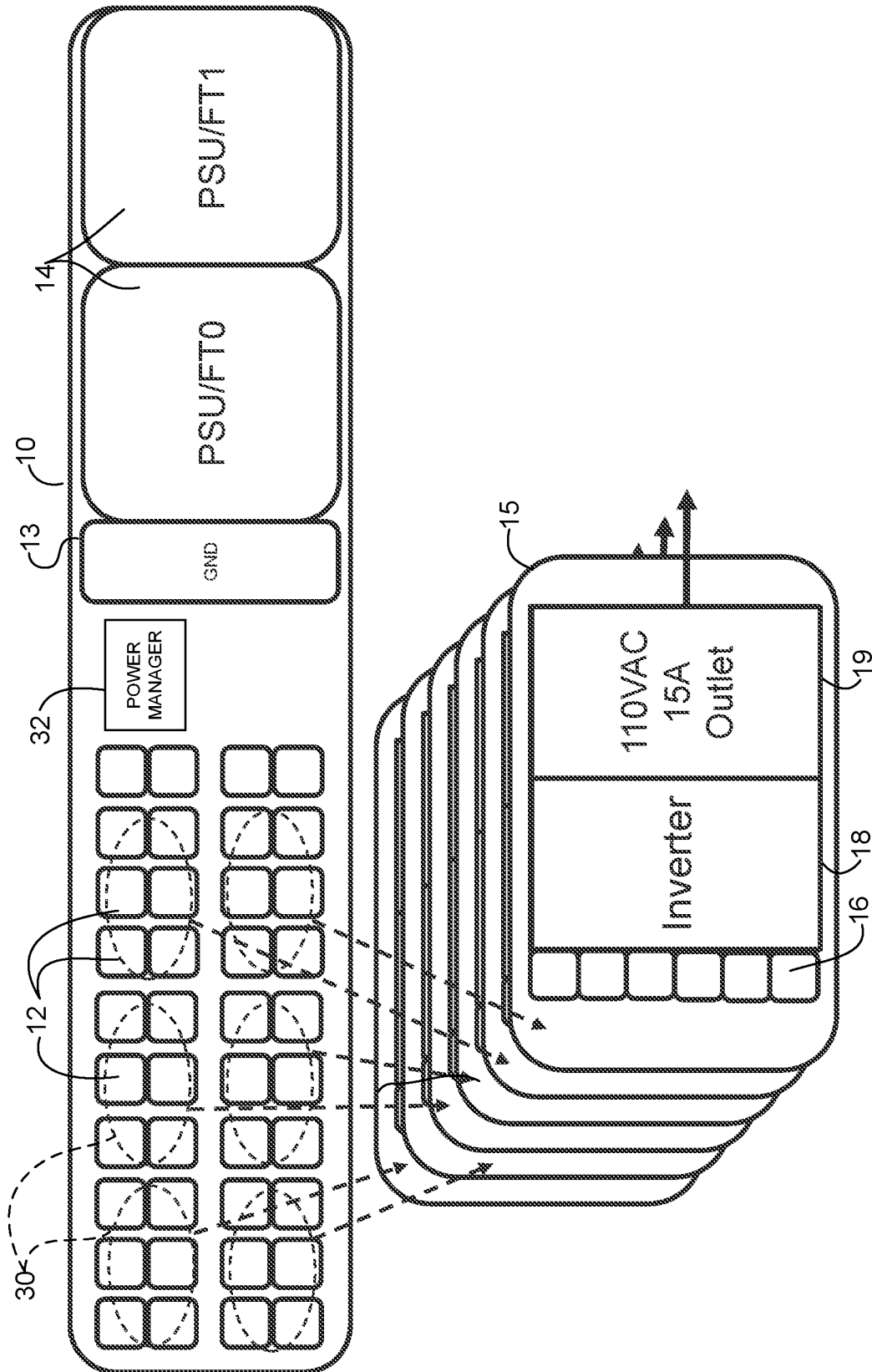

FIGURE 3

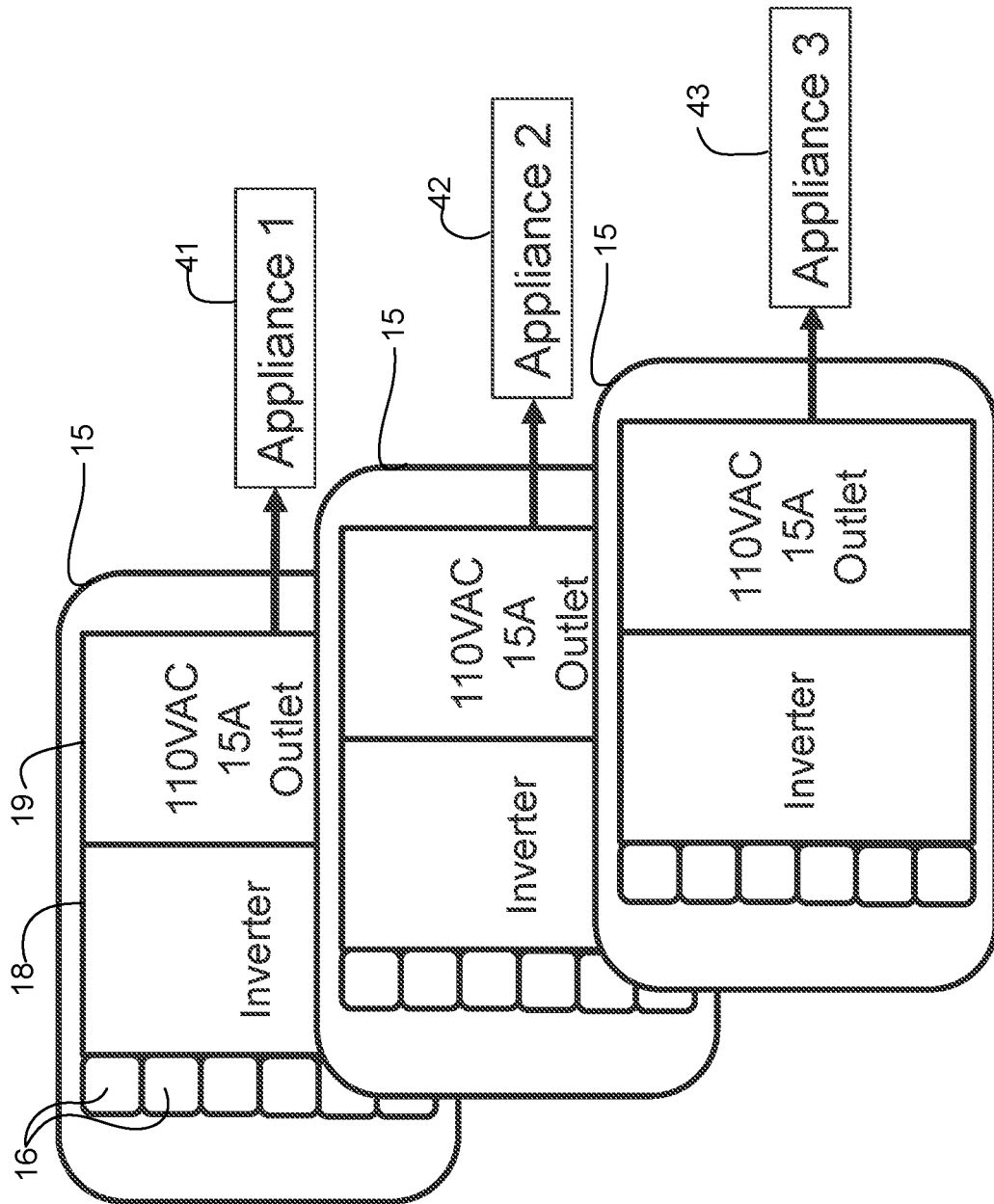

FIGURE 4

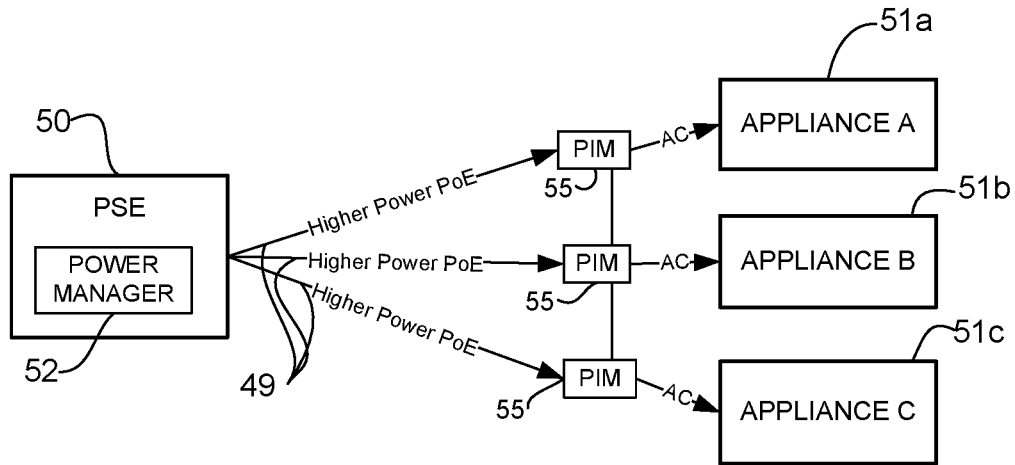

FIGURE 5A

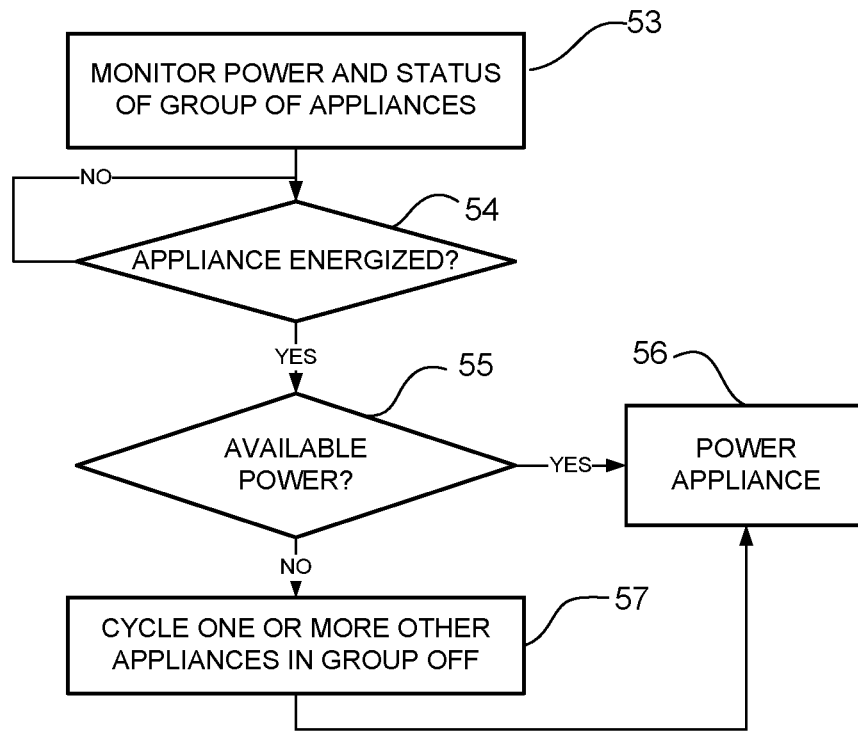

FIGURE 5B

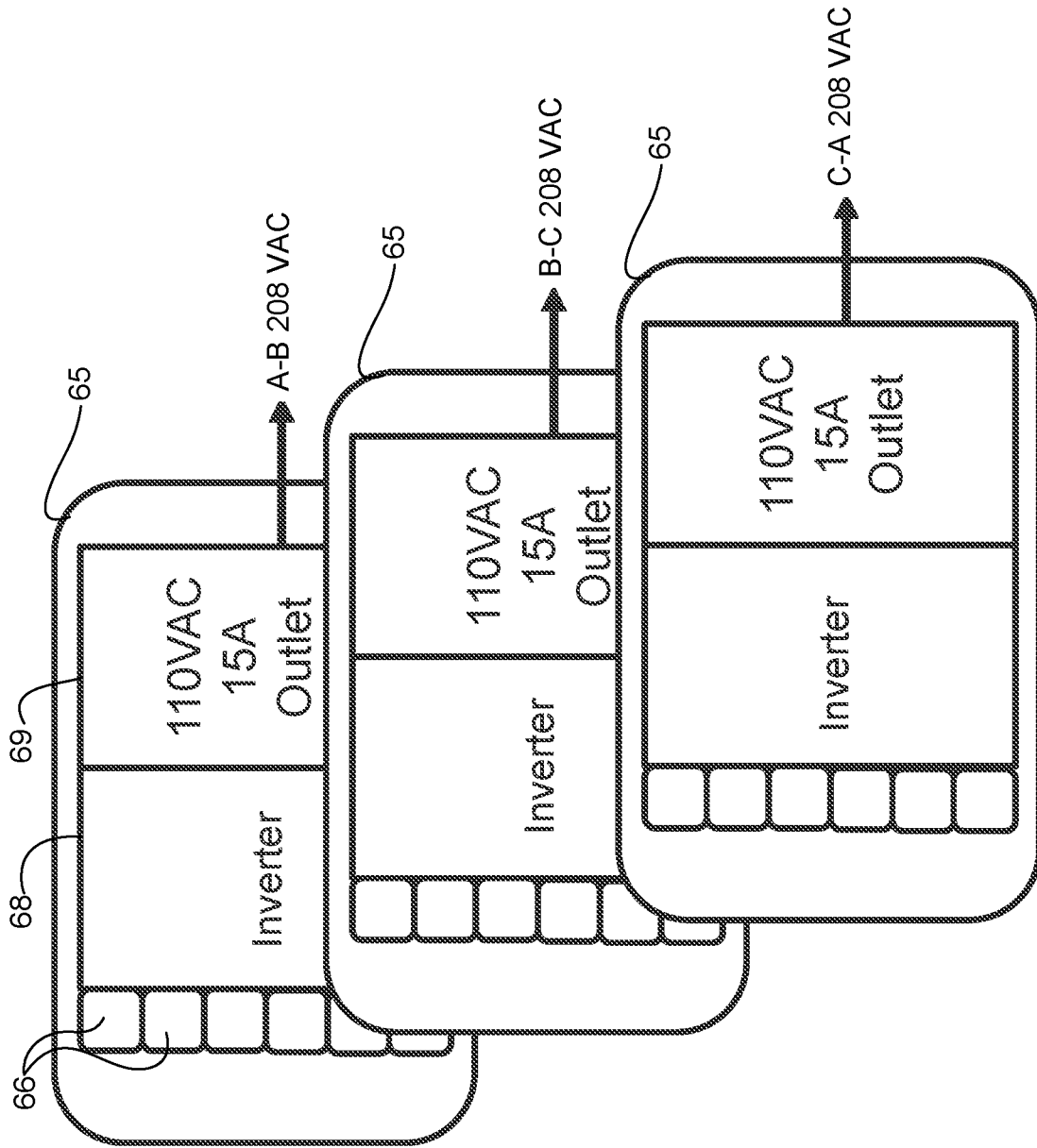

FIGURE 6

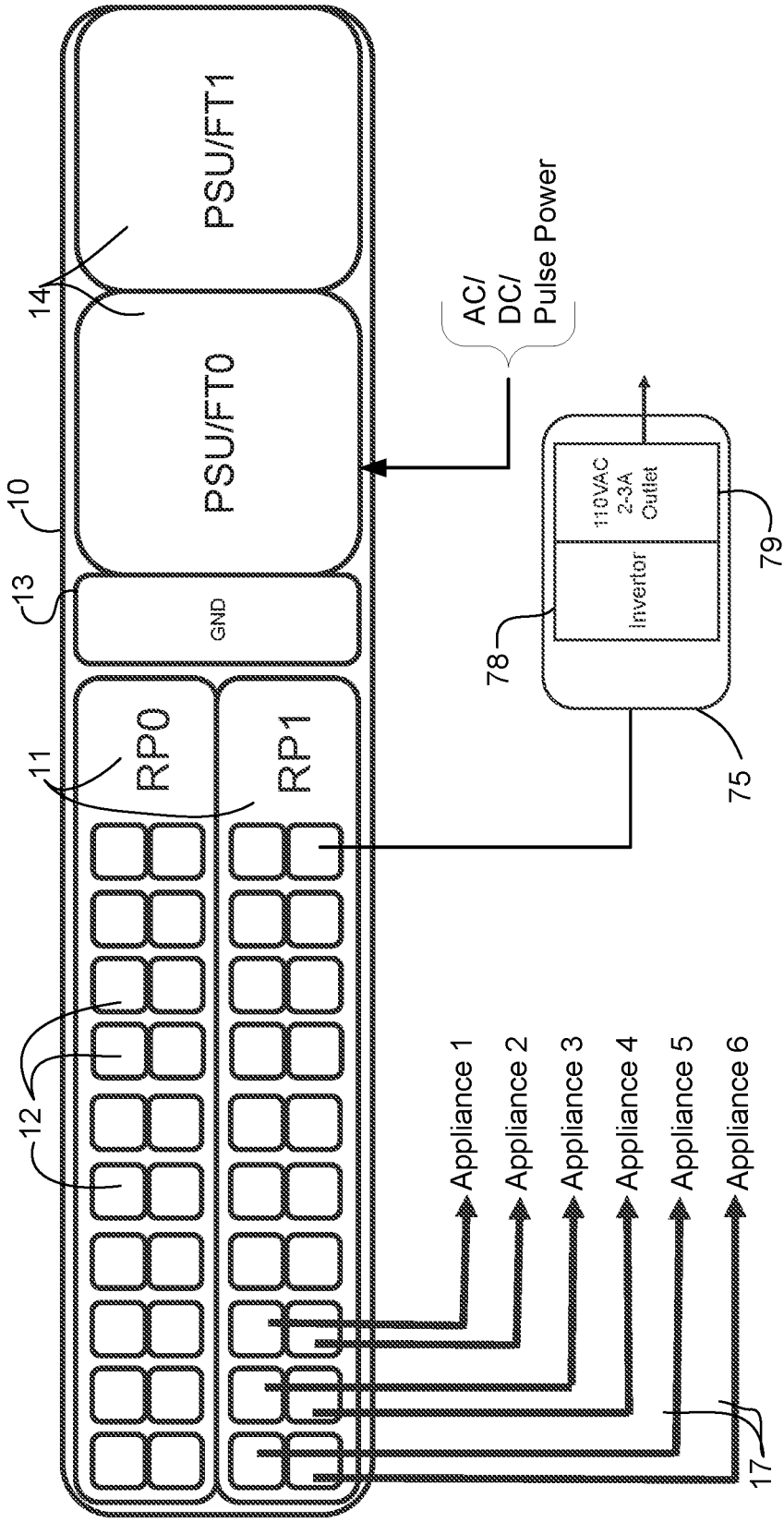

FIGURE 7

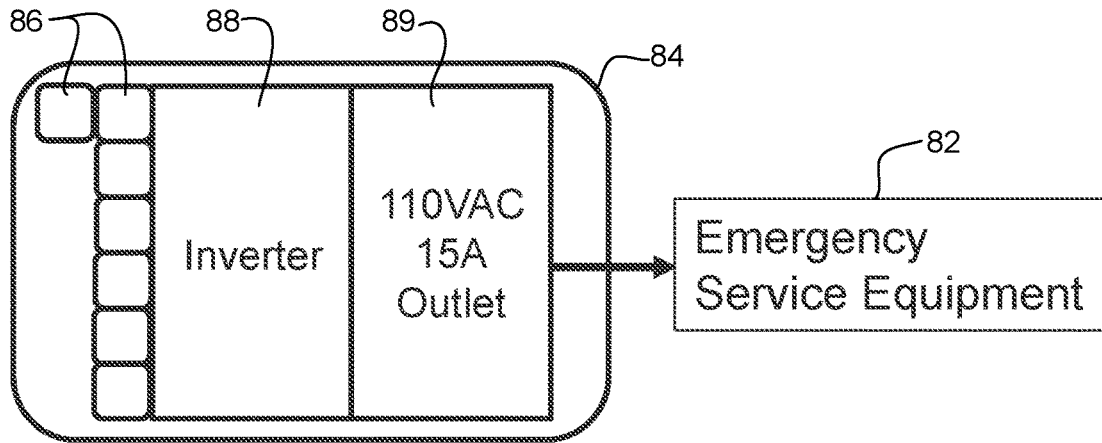

FIGURE 8A

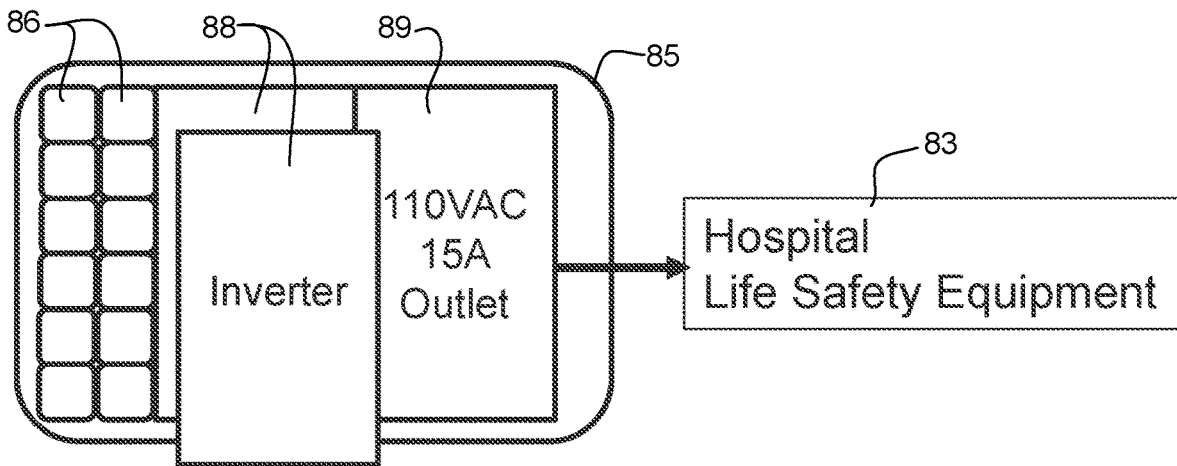

FIGURE 8B

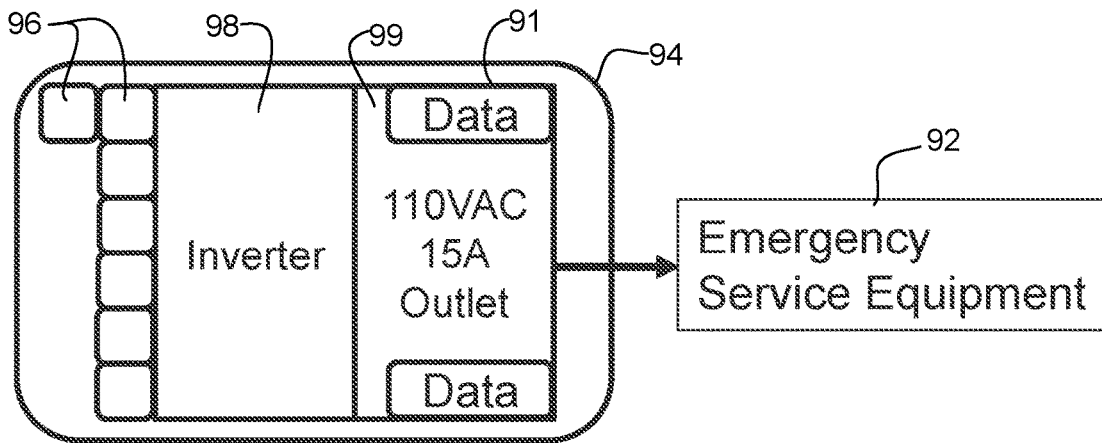

FIGURE 9A

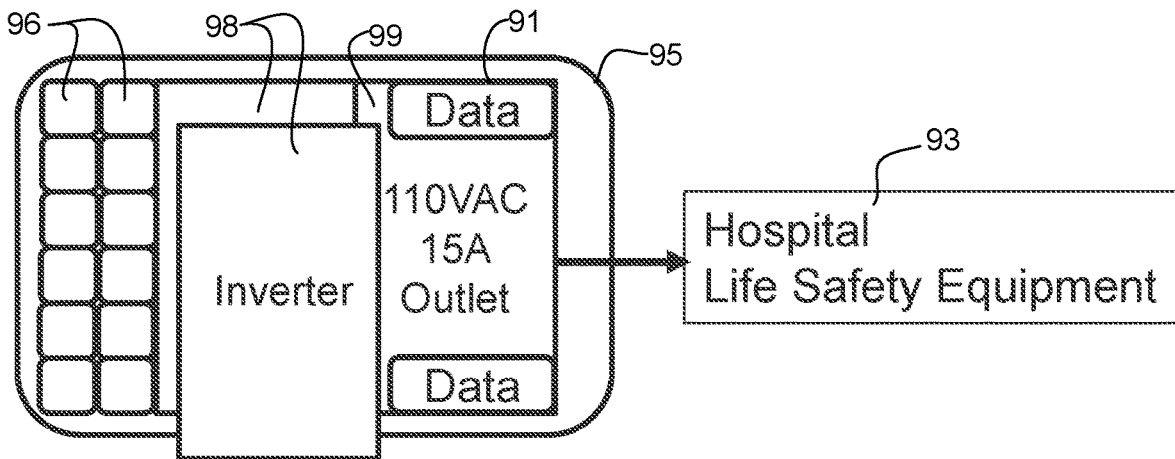

FIGURE 9B

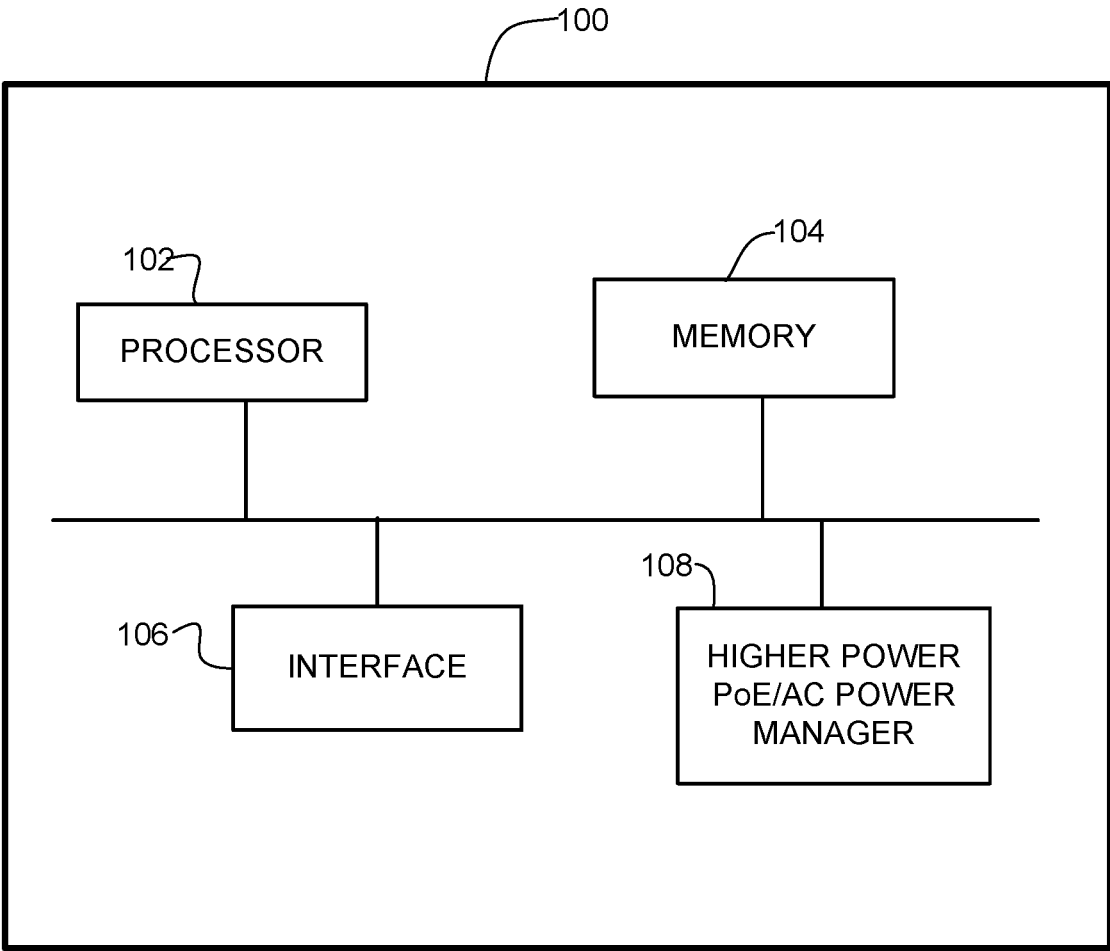

FIGURE 10

DELIVERY OF AC POWER WITH HIGHER POWER POE (POWER OVER ETHERNET) SYSTEMS

STATEMENT OF RELATED APPLICATION

[0001] The present application is a continuation of U.S. patent application Ser. No. 16/040,745, entitled DELIVERY OF AC POWER WITH HIGHER POWER PoE (POWER OVER ETHERNET) SYSTEMS, filed Jul. 20, 2018 (Attorney Docket No. CISCPI343), which claims priority from U.S. Provisional Application No. 62/641,203, entitled DELIVERING AC POWER WITH HIGHER POWER PoE SYSTEMS, filed on Mar. 9, 2018 (Attorney Docket No. CISCPI343+). The contents of these applications are incorporated herein by reference in their entirety.

TECHNICAL FIELD

[0002] The present disclosure relates generally to delivering AC power, and more particularly, to use of higher power PoE systems to power devices with AC power.

BACKGROUND

[0003] Power over Ethernet (PoE) is a technology for providing electrical power over a wired telecommunications network from power sourcing equipment (PSE) to a powered device (PD) over a link section. The maximum power delivery capacity of conventional PoE is approximately 90 watts, but many classes of devices would benefit from higher power PoE.

BRIEF DESCRIPTION OF THE DRAWINGS

[0004] FIG. 1 illustrates a system for delivering higher power PoE to an AC power outlet through combined ports, in accordance with one embodiment.

[0005] FIG. 2 is a flowchart illustrating an overview of a process for combining power from PoE ports at power sourcing equipment to create an AC power outlet, in accordance with one embodiment.

[0006] FIG. 3 illustrates grouping of ports at power sourcing equipment to power multiple AC power outlets, in accordance with one embodiment.

[0007] FIG. 4 illustrates sharing of power transmitted to the AC power outlets of FIG. 3.

[0008] FIG. 5A is a block diagram illustrating a power manager at power sourcing equipment in a higher power PoE system, in accordance with one embodiment.

[0009] FIG. 5B is a flowchart illustrating an overview of a process for sharing a power allotment from power sourcing equipment at a plurality of devices receiving power from AC power outlets, in accordance with one embodiment.

[0010] FIG. 6 illustrates combining higher power PoE to provide three-phase AC power outlets, in accordance with one embodiment.

[0011] FIG. 7 illustrates delivery of PoE through telecommunications cabling directly to higher power devices, in accordance with one embodiment.

[0012] FIGS. 8A and 8B illustrate reliable outlets for emergency service and life safety equipment, in accordance with one embodiment.

[0013] FIGS. 9A and 9B illustrate reliable outlets with data for emergency service and life safety equipment, in accordance with one embodiment.

[0014] FIG. 10 depicts an example of a network device useful in implementing embodiments described herein.

[0015] Corresponding reference characters indicate corresponding parts throughout the several views of the drawings.

DESCRIPTION OF EXAMPLE EMBODIMENTS

Overview

[0016] In one embodiment, a method generally comprises grouping a plurality of ports at power sourcing equipment in a Power over Ethernet (PoE) system, the ports receiving power from at least one power supply, and transmitting power from the group of ports at the power sourcing equipment to a plurality of ports at a power interface module. The power transmitted at each of the ports is at least 100 watts and the power interface module is operable to combine the power received at the plurality of ports and provide an AC outlet.

[0017] In another embodiment, a system generally comprises a power supply, a plurality of ports for receiving power from the power supply, each of the ports configured to transmit at least 100 watts of power in a Power over Ethernet (PoE) system, and a power manager for managing power delivery from the ports. The system is operable to power one or more devices with AC power.

[0018] In yet another embodiment, a system generally comprises power sourcing equipment comprising a power supply and a plurality of ports each configured for transmitting Power over Ethernet (PoE) at a power of at least 100 watts, and a plurality of power interface modules, each of the power interface modules comprising a plurality of ports for communication with a group of the ports at the power sourcing equipment and an AC (alternating current) outlet delivering combined power received at the ports.

[0019] Further understanding of the features and advantages of the embodiments described herein may be realized by reference to the remaining portions of the specification and the attached drawings.

EXAMPLE EMBODIMENTS

[0020] The following description is presented to enable one of ordinary skill in the art to make and use the embodiments. Descriptions of specific embodiments and applications are provided only as examples, and various modifications will be readily apparent to those skilled in the art. The general principles described herein may be applied to other applications without departing from the scope of the embodiments. Thus, the embodiments are not to be limited to those shown, but are to be accorded the widest scope consistent with the principles and features described herein. For purpose of clarity, details relating to technical material that is known in the technical fields related to the embodiments have not been described in detail.

[0021] In order to create an all PoE (Power over Ethernet) port environment within a home, hotel, office space, or other residential or commercial location, there are several obstacles to overcome. These include availability of electrical outlets configured for 120 VAC (Volts Alternating Current)/20 A (amps) (or other standard AC power outlet) for the purpose of powering dishwashers, washing machines, refrigerators, hair dryers, vacuum cleaners, and other

devices (appliances, equipment). These devices typically use higher than 90 W (watts) provided by conventional PoE systems.

[0022] In AC power environments in a home or business, there is typically a minimum number of AC outlets specified in the electrical code for each room. Conventional PoE systems (90 W or less), cannot sufficiently support these AC outlets and therefore cannot meet code requirements.

[0023] The embodiments described herein provide the delivery of power to meet AC power needs in commercial and residential environments in a higher power PoE system. In one or more embodiments, a shared circuit delivery system manages real time power to minimize the total required input power to the PoE system.

[0024] Referring now to the drawings, and first to FIG. 1, an example of a modular system that may be used to deliver power over communications cabling (also referred to herein as higher power or enhanced PoE) for power distribution at higher power levels (e.g., ≥ 100 watts) is shown. The modular system shown in the example of FIG. 1 includes a dual route processor (RP) card chassis **10** supplying control and power over PoE cables **17** to a power interface module **15** operable to combine power received from multiple ports **12** at a route processor **11** and convert PoE DC (direct current) power to AC (alternating current) power and create an AC power outlet.

[0025] It is to be understood that the term AC power outlet as used herein refers to any AC power outlet including standard outlets (e.g., 120 VAC outlet (e.g., 110-125 volts), 110 VAC, 220 VAC, 240 VAC, three-phase 208 VAC) or any other AC outlet for use in a residential or commercial environment.

[0026] The term higher power as used herein refers to power exceeding 90 watts (e.g., ≥ 100 W, 150 W, 300 W, 450 W) and the term lower power as used herein refers to power ≤ 90 watts.

[0027] In the example shown in FIG. 1, the route processor card chassis **10** is a two RU (rack unit) chassis comprising two route processors **11** (RP0, RP1) each comprising twenty downlink ports **12**, a dual port ground system **13**, and two combination power supply unit (PSU) and fan tray modules **14** (PSU/FT0, PSU/FT1). Each downlink port **12** may support, for example, a 300 W power system. In one example, the power supply provides dual 2 kW AC or DC redundant power modules (1+1). In this example, the RP card chassis **10** operates as the PSE (Power Sourcing Equipment) and the power interface module **15** or the device connected to the power interface module **15** is the PD (Powered Device) in the PoE distribution system. In one or more embodiments, the system may include an extended power system to supply four 2 kW redundant power modules (2+2) (e.g., double the delivered power capacity of the RP chassis **10** shown in FIG. 1).

[0028] In the example shown in FIG. 1, the power interface module **15** includes six ports **16** receiving power from a group of six 300 W ports **12** at the PSE **10** to provide an 1800 W circuit. The power interface module **15** comprises an inverter **18** for converting (changing) received DC power to AC power to create an AC power outlet **19** (e.g., outlet providing 110 VAC/15 A (amp ampere)) power as shown in FIG. 1). In one example, the module **15** combines power received at the six ports **16** and changes 54 VDC power to 110 VAC power. In this example, the power inverter **18** may

scale from 400 W to 1800 W based on port power availability and power allocation for those ports.

[0029] The cables **17** are configured to transmit both power and data from the PSE **10** to the power interface module **15**. The cables **17** may be formed from any material suitable to carry both power and data. The cables **17** may comprise, for example Catx cable (e.g., category **5** twisted pair (e.g., four-pair) Ethernet cabling) or any other type of cable. The cables **17** may be arranged in any configuration. The cable **17** may be rated for one or more power levels, a maximum power level, a maximum temperature, or identified according to one or more categories indicating acceptable power level usage, for example. In one example, the cables **17** correspond to a standardized wire gauge system such as AWG (American Wire Gauge).

[0030] In one embodiment, the ports **12**, **16** comprise interconnect ports that combine data and PoE utilizing an RJ45 (or similar connector) connected to cable **17**. For example, the cable and connector system may comprise RJ45 cat7 style, four-pair communications cabling. The ports (jacks) **12**, **16** may be labeled to identify capability for power exceeding 90 W. In one example, the cable and connector system may support ampacity per pin or wire to 2000 ma minimum.

[0031] For example, 22 AWG wire may be used to support 1500 ma-2000 ma per wire in a cat7/cat5e cable system. In one example, the system may support a cable length of up to 15 meters (based on technology of cat7 cable, 22 AWG at 300 W). In one or more embodiments, the internal PSE power supply voltage may operate in the 56V to 57V range, 57V to 58V range, or 56V to 58V range. For example, the output voltage at the PSE may be 57V with an input voltage at the power interface module **15** of 56V. For a 15 meter cable, a 56V power supply at the PSE can deliver approximately 300 W power. Other cable lengths, cable types, and power settings may also be used.

[0032] The system may include, for example, safety and fault detection systems as described in U.S. patent application Ser. Nos. 16/020,881 and 16/020,917, filed Jun. 27, 2018, which are incorporated herein by reference in their entirety. For PoE applications exceeding 100 W, safety systems may include, for example, a fault detection system to detect shorts, opens, electrical imbalance, exceeding ampacity limits, or life safety concerns. In one or more embodiments, the power may be applied at a low power setting (e.g., ≤ 90 W) and increased to higher power after safe operating conditions have been verified. The system may, for example, cycle through and check each wire at the port or look for an electrical imbalance between wires or pairs of wires. The safety system may also identify that the correct cable/connector assembly is used for delivered power on the PoE port and provide for reduced load cable removal to allow for safe removal of the cable and plug from a powered jack.

[0033] The PSE (e.g., route processor chassis **10**, route processor **11**, or any routing device (e.g., network device (router, switch) operable to route, switch, or forward data) may be in communication with any number of power interface modules **15** via cables **17**, as described below with respect to FIG. 3. The PSE may be configured to deliver power at one or more output levels (e.g., programmable PoE) and is provided power by at least one power supply unit **14**. The PSE **10** may receive power from a DC power,

AC power, or pulse power (PP) source. For example, as shown in FIG. 1, each PSU 14 may receive DC power, AC power, or pulse power.

[0034] In one or more embodiments, the PSE 10 may receive high power PoE (e.g., ≥ 1000 watts) as described in U.S. patent application Ser. No. 15/707,976 (“Power Delivery Through an Optical System”, filed Sep. 18, 2017) or U.S. patent application Ser. No. 15/910,203 (“Combined Power, Data, and Cooling Delivery in a Communications Network”), filed Mar. 2, 2018, which are incorporated herein by reference in their entirety.

[0035] It is to be understood that the PoE system shown in FIG. 1 is only an example, and other arrangements (e.g., number of route processors 11, PSUs 14, power interface modules 15, ports 12, 16, or port groupings) may be used without departing from the scope of the embodiments. Furthermore, the connectors (jacks, plugs), cables, cable lengths, and power ranges described herein are only examples and other types of connectors, lengths of cable, type of cable systems, safety systems, or power levels may be used without departing from the scope of the embodiments.

[0036] FIG. 2 is a flowchart illustrating an overview of a process for combining higher power PoE to provide one or more AC outlets, in accordance with one embodiment. At step 20, a plurality of ports 12 are grouped at power sourcing equipment 10 (FIGS. 1 and 2). As described above, each port 12 provides higher power PoE (e.g., ≥ 100 W, 300 W, 450 W). The PSE 10 transmits the higher power PoE from each port 12 in the group to the power interface module 15 (step 22). The power received at the ports of the power interface module is combined and converted to provide an AC outlet (e.g., 120 VAC outlet) (step 24).

[0037] It is to be understood that the process shown in FIG. 2 and described above is only an example and that steps may be modified or added, without departing from the scope of the embodiments.

[0038] FIG. 3 illustrates an example in which port management is used to link two or more groups of ports to share an allotment of power. As previously described with respect to FIG. 1, an AC outlet 19 (e.g., 120 VAC outlet) may be created at some usable ampacity, such as 15 A or 20 A, by combining multiple ports 12 at the PSE 10. In the case of 300 W ports, six ports may be combined to deliver 110 VAC at 15 A. In the example shown in FIG. 3, ports 12 at the PSE 10 are grouped into six port groups 30, each group comprising six ports. Each port group 30 provides power to one power interface module 15 comprising six ports 16, the inverter 18, and the AC power outlet 19, as described above with respect to FIG. 1.

[0039] For residential or commercial applications, it is common practice to place up to eight 120 VAC power outlets on a 20 A circuit, or six to eight outlets on a 15 A circuit. The PoE power distribution described herein may be used to deliver all power to the AC power outlets through communications cables. In the example shown in FIG. 3, six groupings 30 of six 300 W ports 12 are used to create six AC outlets 19 that can handle 15 A on the same circuit. Since it is desirable to not allocate 1800 W to each of the six groupings of six ports, 1800 W may be allocated across the groupings. This allows communications wiring supporting PoE to be used for each outlet 19, with the power allocated

across each outlet, thereby mirroring a typical AC power outlet installation of six outlets attached to a single 15 A circuit breaker.

[0040] In one or more embodiments, management software (power manager 32) supports an electronic circuit breaker that manages the total 1800 W for the six groupings 30 such that when all six groupings exceed the 1800 W maximum current allocation, all ports are powered down until a reset is initiated. This allows the entire circuit to perform in a similar manner as to how six conventional power outlets on a 15 A circuit would perform. In one or more embodiments, the power management system prioritizes which grouping of ports in the set of groups can allocate from one allotment zone of multiple allotment zones, as described below with respect to FIG. 4.

[0041] For simplification, the PSE 10 of FIG. 1 is not shown in FIGS. 4, 6, 8A, 8B, 9A, and 9B. The power interface modules shown in those Figures may receive higher power PoE from a PSE as described above with respect to FIGS. 1 and 3, for example.

[0042] FIG. 4 illustrates three of the power interface modules 15 shown in FIG. 3 with each interface module in communication with a different appliance (device) 41, 42, 43 (Appliance 1, Appliance 2, Appliance 3). The appliance may comprise, for example, a refrigerator, garbage disposal, dishwasher, washing machine, hair dryer, vacuum, garage door opener, sprinkler system, water heater, or any other electronic device, appliance, or equipment. The outlets 19 may share, for example, the same 1800 W power allocation and the power management system 32 is operable to disable one or more of the appliances to allow other appliances to operate over a short duration (FIGS. 3 and 4). The power may also be allocated to different outlets in the same group block.

[0043] In one example, the six port groupings 30 with six ports 12 per group are managed to mimic six outlets as a 15 A circuit with management software prioritizing group power allocation based on priority use of a particular residential or commercial application. For example, one port group 30 assigned to appliance 41 (via power interface module 15) may have power suspended for a time period acceptable to power down the appliance 41 so that this power can be re-allocated to other groupings of ports assigned to the same 15 A allocated circuit and power one or more other appliances 42, 43. The power manager 32 may disable the appliance by shutting off power at the corresponding PSE ports 12 or by sending a message to the power interface module 15.

[0044] In another example, a dishwasher (Appliance 1), refrigerator (Appliance 2), and garbage disposal (Appliance 3) may all use the same 15 A circuit (FIG. 4). When the dishwasher is energized, the refrigerator can be disabled for a period of time (e.g., five minutes), and then the dishwasher can be disabled for a period of time, with the refrigerator turned back on during that period to continue operating to reach the appropriate required cold temperature. The cycle may then repeat as needed. In another example, energizing the garbage disposal may temporarily disable other units on the line. With this level of power management on a 15 A 110 VAC circuit, power may be effectively allocated across various devices without allocating separate 15 A circuits. The embodiments thus allow the entire system to operate more efficiently, at a lower cost, and with more flexibility.

[0045] It is to be understood that the arrangement shown in FIG. 4 is only an example and that any number of power interface modules 15 may be in communication with any number of devices to share a power allotment from the PSE.

[0046] FIG. 5A is a block diagram illustrating a power manager 52 at a PSE 50 in communication with three appliances 51a, 51b, 51c (Appliance A, Appliance B, Appliance C) through power interface modules (PIMs) 55. PSE 50 provides higher power PoE to the power interface modules 55 over cables 49.

[0047] The cables 49 may also transmit control signaling and status information between the power manager 52 and power interface modules 55 or appliances 51a, 51b, 51c. The power interface module 55 delivers AC power to the appliance (e.g., for non-PoE applications) and may also transmit data (PoE) to or from a smart appliance. Connections between the PIMs 55 allow sharing of AC power between the PIMs to provide power sharing between the appliances 51a, 51b, 51c. The power manager 52 may store information (e.g., profile stored in database or programmed) for each appliance identifying appropriate power cycles (e.g., how long an appliance may be powered down, power needed for operation, time for operation, etc.) for use in selecting appliances to power down and how long to power down. In one or more embodiments, the power manager 52 makes decisions as to which appliance to power down or how long to power down the appliance based on available power and power requirements of the appliances, without receiving input from the appliances (e.g., power manager does not negotiate power allocation with power interface module or appliances).

[0048] FIG. 5B is a flowchart illustrating an overview of a process for shared power allocation, in accordance with one embodiment. At step 53, a power management system (e.g., power manager 52 in FIG. 5A) monitors power and status of a group of devices (e.g., appliances 51a, 51b, 51c in FIG. 5A). Each appliance may be associated with a profile identifying its power needs. For example, a refrigerator may have a profile that specifies that it can be powered down for a limited time period (e.g., five minutes or any other suitable time period). If sufficient power is available, the appliance will be powered on as needed (steps 55 and 56). If there is not sufficient power available when an appliance is energized (e.g., garbage disposal activated), the power manager 52 identifies one or more other appliances (e.g., refrigerator) for which power can be temporarily reduced or turned off (steps 55 and 57). If an appliance runs for an extended period of time (e.g., dishwasher), the power manager may cycle other appliances on and off, as needed. Each appliance may have a default profile or the power manager may be programmed for specific equipment or user needs.

[0049] It is to be understood that the system shown in FIG. 5A and the process shown in FIG. 5B and described above are only examples and that the system may include additional components or the process may include additional or different steps without departing from the scope of the embodiments.

[0050] FIG. 6 illustrates combining PoE power to provide one or more three-phase AC power outlets, in accordance with one embodiment. Three distinct but related groupings may be used to create the three-phase power. In the example shown in FIG. 6, each power interface module 65 comprises six ports 66 and an inverter 68 for creating a 208 VAC three-phase power outlet 69 (A-B 208 VAC, B-C 208 VAC,

C-A 208 VAC). In this example, powering of a 15 A circuit with six 300 W ports may be scaled such that three groupings of six ports 66 can deliver power to the inverter 68, with the inverter creating three separate phases with phase-to-phase voltage of 208 VAC. Each inverter circuit may be phased current in a standard delta or Y configuration. The three managed groups of six ports per group may effectively control phase-to-phase imbalance by lowering voltage slightly on a single phase, or adjusting current per phase as needed to maximize power factor.

[0051] The circuit shown in FIG. 6 may be used to power, for example, an L6 or L14 type AC outlet used in various applications in a residential or commercial environment. Communications cable may be used to deliver power to the three-phase load such that minimal electrical system build out is needed. This eliminates the need to build out AC electrical systems and allows communications cabling to deliver power to AC electrical system outlets based on growth or demand. In one or more embodiment, pulse power may be provided to the PSE and converted to AC power, as previously described.

[0052] For applications that have low enough power needs (e.g., some vacuum cleaners, refrigerators, or garage door openers), it is possible to directly connect the PoE cable to those devices, as shown in FIG. 7. The devices may be connected via typical RJ45 Ethernet jacks, for example, and may benefit from Ethernet connectivity. The appliances (e.g., Appliance 1, Appliance 2, Appliance 3, Appliance 4, Appliance 5, Appliance 6 in FIG. 7) may include, for example, a vacuum, garage door, sprinkler system, water heater, or any other appliance, device, or equipment. In one example, the PSE 10 may provide 450 W power per port. If the PoE power source is battery backed, applications such as garage doors may still open or close when AC power is unavailable (e.g., power outage).

[0053] In one or more embodiments, a managed PoE port to a garage door opener (or other device or appliance) may be programmed or allow other avenues of control. In one example, when residents are away from home on a trip, the PoE power to the garage door opener may be limited until an Ethernet packet is sent to enable full power. This would prevent others from opening the garage door. In this example, the power is only restored via a managed command to the power manager.

[0054] As shown in FIG. 7, one or more of the ports 12 may deliver power to a PIM (power interface module) 75 comprising an inverter 78 and an AC outlet 79 (e.g., 110 VAC, 2-3 amp). The outlet 79 may be used, for example, to power a phone charger, laptop, or other device. As previously described, the PSUs 14 may receive AC power, DC power, or pulse power. In one example, one or more of the ports 12 may provide a direct flow through of power to one or more devices (e.g., Appliance 1-6 in FIG. 7), one or more ports may individually provide power to an AC outlet 79 (FIG. 7), and a group of ports 12 may provide power to an AC outlet 19 (FIG. 1). Thus, the ports 12 at the PSE 10 may be used for multiple applications, either individually or in groups. The PSE 10 may be used, for example, to provide power for devices or appliances in a residence, business, hotel room, or other environment.

[0055] FIGS. 8A, 8B, 9A, and 9B illustrate examples of reliable outlets that may be used to power emergency service equipment 82, 92 or life safety equipment (e.g., hospital equipment) 83, 93. Priority power may be allocated to life

safety circuits, emergency systems, critical systems, and then general availability, in this order, for example. Power management software may be used to reorganize or prioritize in a different order.

[0056] Each power interface module **84**, **85**, **94**, **95** comprises ports **86**, **96** and one or more inverters **88**, **98**. In one example, all outlets share the same 1800 W power allocation. An emergency services outlet **89**, **99** is shown in a 6+1 cabling configuration. Powering of a 15 A circuit with six 300 W ports may be made more reliable by adding a single cable (6+1) (FIGS. **8A** and **9A**). In this configuration, the system now has increased reliability in the unlikely event of a conductor, cable, connector, or port power fault condition. A life safety outlet is shown in a 6+6 cabling configuration for improved backup and reliability (FIGS. **8B** and **9B**). Powering the same inverter circuit in a 6+6 configuration has the additional ability to provide redundant switch systems where some ports come from one switch system and some ports come from other switch systems powering the AC circuit. In this manner, at least two switch systems provide PoE power to the inverter circuit **88**, **98**. The system may include dual inverters **88**, **98** as shown in FIGS. **8B** and **9B**, with one inverter powered by six ports **86**, **96** and the second inverter powered by the other six ports.

[0057] In one example, six ports **86**, **96** may receive power from one UPS (Uninterruptible Power Supply) driven switch and the other six ports may receive power from a second UPS driven switch. All twelve ports **86**, **96** may be served from one UPS backed switch if cable reliability is the only concern. However, true redundancy with at least two switches may be preferred. In another example, four groups of three ports may receive power from four UPS backed switches.

[0058] As shown in FIGS. **9A** and **9B** the AC outlets **99** may also include data ports **91** with data connectivity provided by the PoE cables.

[0059] It is to be understood that the higher power PoE systems, network devices (switches, routers), appliances, power levels, current ranges, number of ports, size of port groupings, sharing of power, and power allocation described herein are only examples and that other systems, devices, appliances, arrangements, power levels, or power control/management may be used, without departing from the scope of the embodiments.

[0060] FIG. **10** illustrates an example of a network device **100** (e.g., transport system, route processor card chassis in FIG. **1**) that may be used to implement the embodiments described herein. In one embodiment, the network device **100** is a programmable machine that may be implemented in hardware, software, or any combination thereof. The network device **100** includes one or more processors **102**, memory **104**, interface **106**, and higher power PoE/AC power manager module **108**.

[0061] Memory **104** may be a volatile memory or non-volatile storage, which stores various applications, operating systems, modules, and data for execution and use by the processor **102**. For example, components of the power manager module **108** (e.g., code, logic, or firmware, etc.) may be stored in the memory **104**. The network device **100** may include any number of memory components.

[0062] The network device **100** may include any number of processors **102** (e.g., single or multi-processor computing device or system), which may communicate with a forwarding engine or packet forwarder operable to process a packet

or packet header. The processor **102** may receive instructions from a software application or module, which causes the processor to perform functions of one or more embodiments described herein.

[0063] Logic may be encoded in one or more tangible media for execution by the processor **102**. For example, the processor **102** may execute codes stored in a computer-readable medium such as memory **104**. The computer-readable medium may be, for example, electronic (e.g., RAM (random access memory), ROM (read-only memory), EPROM (erasable programmable read-only memory)), magnetic, optical (e.g., CD, DVD), electromagnetic, semiconductor technology, or any other suitable medium. In one example, the computer-readable medium comprises a non-transitory computer-readable medium. Logic may be used to perform one or more functions described above with respect to the flowcharts of FIGS. **2** and **5B** or other functions described herein. The network device **100** may include any number of processors **102**.

[0064] The interface **106** may comprise any number of interfaces or network interfaces (line cards, ports, connectors) for receiving data or power, or transmitting data or power to other devices. The network interface may be configured to transmit or receive data using a variety of different communications protocols and may include mechanical, electrical, and signaling circuitry for communicating data over physical links coupled to the network or wireless interfaces. For example, line cards may include port processors and port processor controllers. The interface **106** may be configured for PoE, enhanced PoE, higher power PoE, PoE+, UPoE, or similar operation.

[0065] It is to be understood that the network device **100** shown in FIG. **10** and described above is only an example and that different configurations of network devices may be used. For example, the network device **100** may further include any suitable combination of hardware, software, algorithms, processors, devices, components, or elements operable to facilitate the capabilities described herein.

[0066] The embodiments described herein may operate in the context of a data communications network including multiple network devices. The network may include any number of network devices in communication via any number of nodes (e.g., routers, switches, gateways, controllers, access points, or other network devices), which facilitate passage of data within the network. The network devices may communicate over or be in communication with one or more networks (e.g., local area network (LAN), metropolitan area network (MAN), wide area network (WAN), virtual private network (VPN) (e.g., Ethernet virtual private network (EVPN), layer 2 virtual private network (L2VPN)), virtual local area network (VLAN), wireless network, enterprise network, corporate network, data center, Internet of Things (IoT), Internet, intranet, or any other network).

[0067] Although the method and apparatus have been described in accordance with the embodiments shown, one of ordinary skill in the art will readily recognize that there could be variations made to the embodiments without departing from the scope of the invention. Accordingly, it is intended that all matter contained in the above description and shown in the accompanying drawings shall be interpreted as illustrative and not in a limiting sense.

What is claimed is:

1. A method comprising:
 - grouping a plurality of ports at power sourcing equipment receiving pulse power; and
 - transmitting power from the group of ports at the power sourcing equipment to a power interface module operable to combine said power and provide an AC (alternating current) outlet configured to provide AC power to one or more devices.
2. The method of claim 1 wherein each of the ports transmits Power over Ethernet (PoE) at a power level of at least 100 watts.
3. The method of claim 1 wherein each of the ports transmits at least 300 watts of power.
4. The method of claim 1 wherein grouping said plurality of ports comprises grouping said plurality of ports into multiple groups of ports at the power sourcing equipment, each of the groups of ports transmitting said power to different power interface modules.
5. The method of claim 4 wherein said power is shared among the power interface modules and further comprising allocating power from the power sourcing equipment to the power interface modules.
6. The method of claim 4 further comprising temporarily reducing said power to one of the power interface modules to provide said power to another one of the power interface modules.
7. The method of claim 1 wherein the AC outlet comprises a 120 VAC outlet.
8. The method of claim 1 wherein the power sourcing equipment comprises a card chassis comprising said plurality of ports.
9. A method comprising:
 - receiving DC (direct current) pulse power at a network device;
 - converting the DC pulse power to AC (alternating current) power; and
 - providing the AC power at an AC outlet configured to power one or more devices.
10. The method of claim 9 further comprising converting the DC pulse power to Power over Ethernet (PoE) at the network device and transmitting the PoE to a power interface module operable to convert the PoE to the AC power.
11. The method of claim 10 wherein transmitting the PoE comprises transmitting the PoE at a plurality of ports to the power interface module, the power interface module operable to combine the PoE received at the plurality of ports.
12. A method comprising:
 - transmitting DC power to a plurality of power interface modules operable to convert the DC power to AC (alternating current) power for powering a plurality of devices;
 - monitoring power at said plurality of devices; and
 - signaling one of the power interface modules to reduce power at one of the devices when power required at said plurality of devices exceeds an available power.
13. The method of claim 12 wherein monitoring the power comprises monitoring the power at a power manager comprising a power profile for each of said plurality of devices for use in selecting the device at which to reduce the power.
14. The method of claim 12 wherein said plurality of devices comprises a plurality of appliances.
15. The method of claim 12 wherein the DC power comprises Power over Ethernet and further comprising transmitting the PoE directly to a PoE powered device.
16. A system comprising:
 - a network device configured for receiving pulse power;
 - a plurality of ports at the network device, each of the ports configured to transmit Power over Ethernet (PoE); and
 - a power interface module configured for receiving the PoE from at least one of the ports and converting the PoE to AC (alternating current) power to provide an AC outlet configured to provide the AC power to one or more devices.
17. The system of claim 16 wherein the network device comprises a chassis card.
18. The system of claim 16 wherein the AC outlet comprises a 120 VAC outlet.
19. The system of claim 16 further comprising a power manager operable to reduce power at one or more of the power interface modules.
20. The system of claim 16 wherein at least one of the ports provides the PoE for direct input to power a PoE powered device.

* * * * *