



(19) **United States**

(12) **Patent Application Publication**
SUZUKI et al.

(10) **Pub. No.: US 2020/0328712 A1**

(43) **Pub. Date: Oct. 15, 2020**

(54) **ELECTRIC WORKING MACHINE, AND METHOD FOR SUPPLYING ELECTRIC POWER TO CONTROLLER OF ELECTRIC WORKING MACHINE**

Publication Classification

(51) **Int. Cl.**
H02P 27/06 (2006.01)
B25F 5/02 (2006.01)
(52) **U.S. Cl.**
CPC *H02P 27/06* (2013.01); *B25B 21/02* (2013.01); *B25F 5/02* (2013.01)

(71) Applicant: **MAKITA CORPORATION**, Anjo-shi (JP)

(72) Inventors: **Hitoshi SUZUKI**, Anjo-shi (JP);
Akihiro NAKAMOTO, Anjo-shi (JP)

(73) Assignee: **MAKITA CORPORATION**, Anjo-shi (JP)

(57) **ABSTRACT**

An electric working machine in one aspect of the present disclosure includes a driving device, a controller, a control power source, and an operation state determiner. The control power source includes a first converter and a second converter. The control power source transitions to a first conversion state when the operation state determiner determines that the controller is in a control operation state. The control power source in the first conversion state supplies a first control current to the controller. The control power source transitions to a second conversion state when the operation state determiner determines that the controller is in a low power operation state. The control power source in the second conversion state (i) stops operation of the first converter, and (ii) supplies a second control current to the controller.

(21) Appl. No.: **16/832,443**

(22) Filed: **Mar. 27, 2020**

(30) **Foreign Application Priority Data**

Apr. 11, 2019 (JP) 2019-075684
Jun. 5, 2019 (JP) 2019-105681

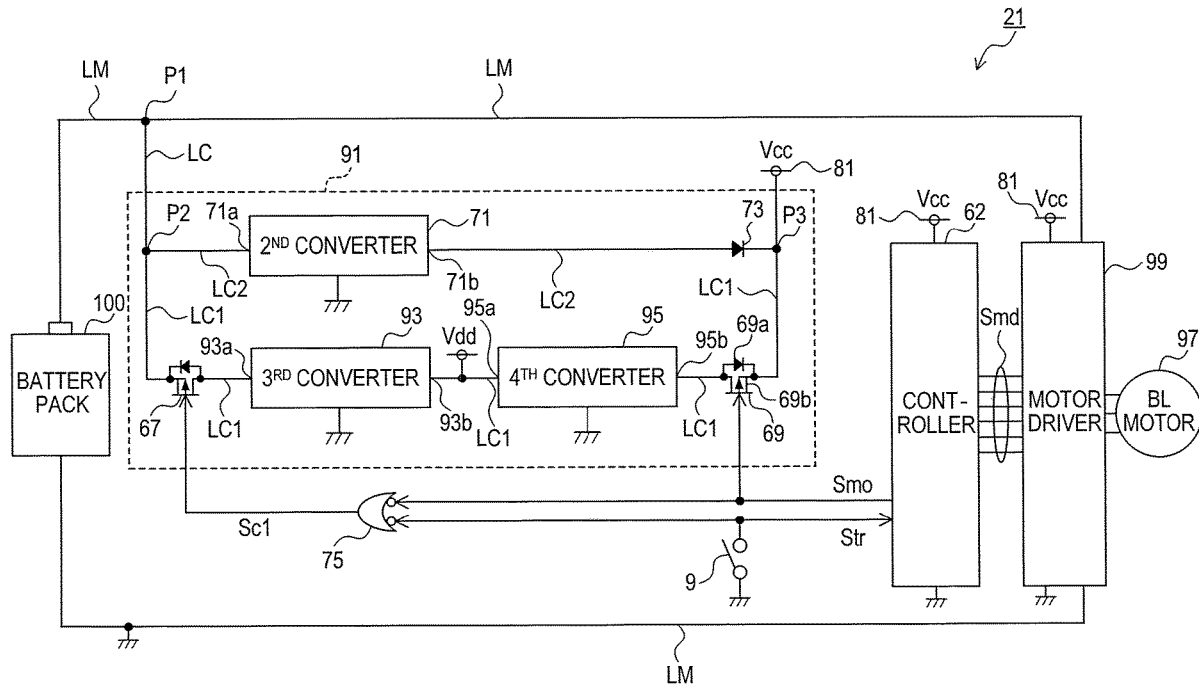

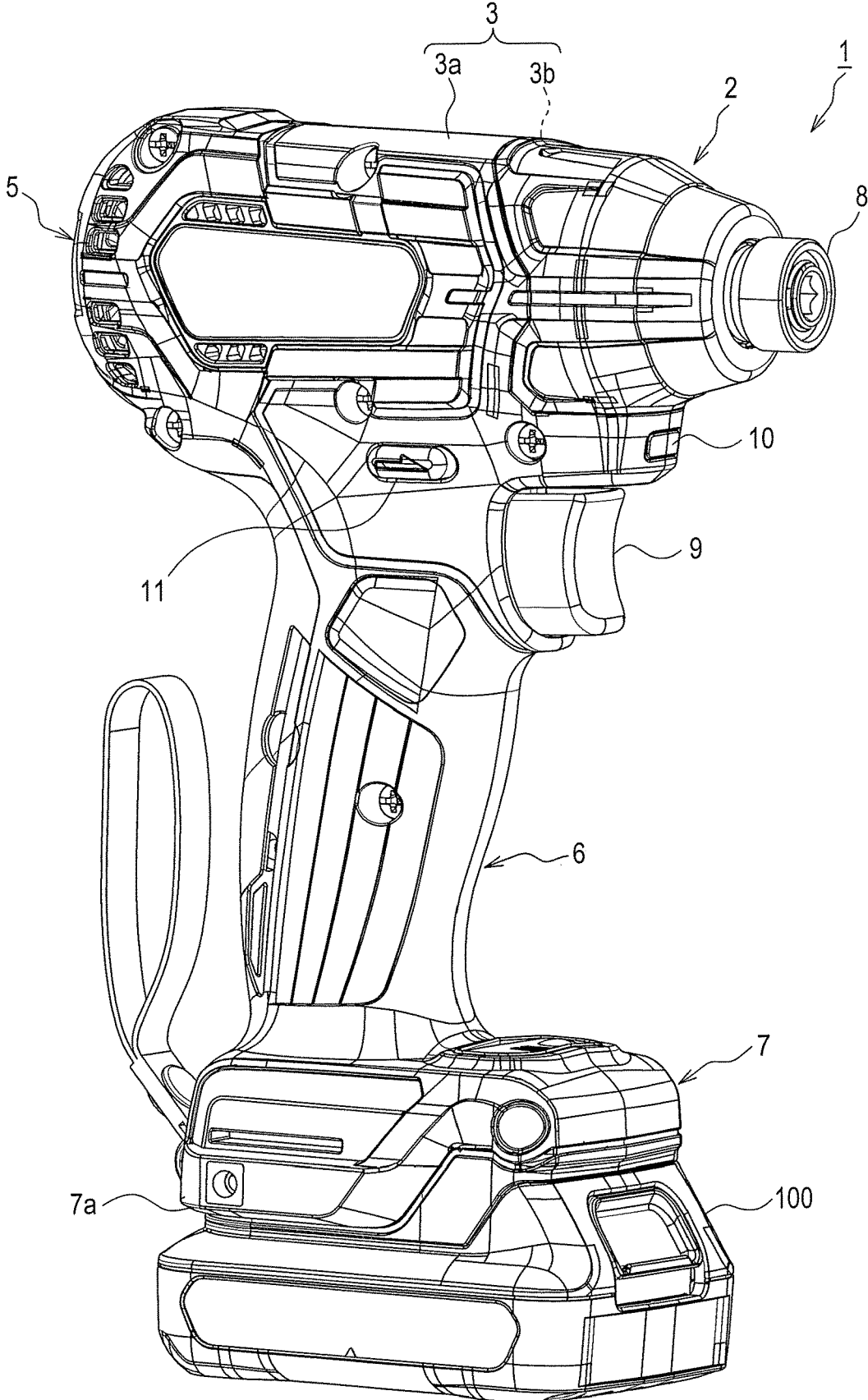

FIG. 1

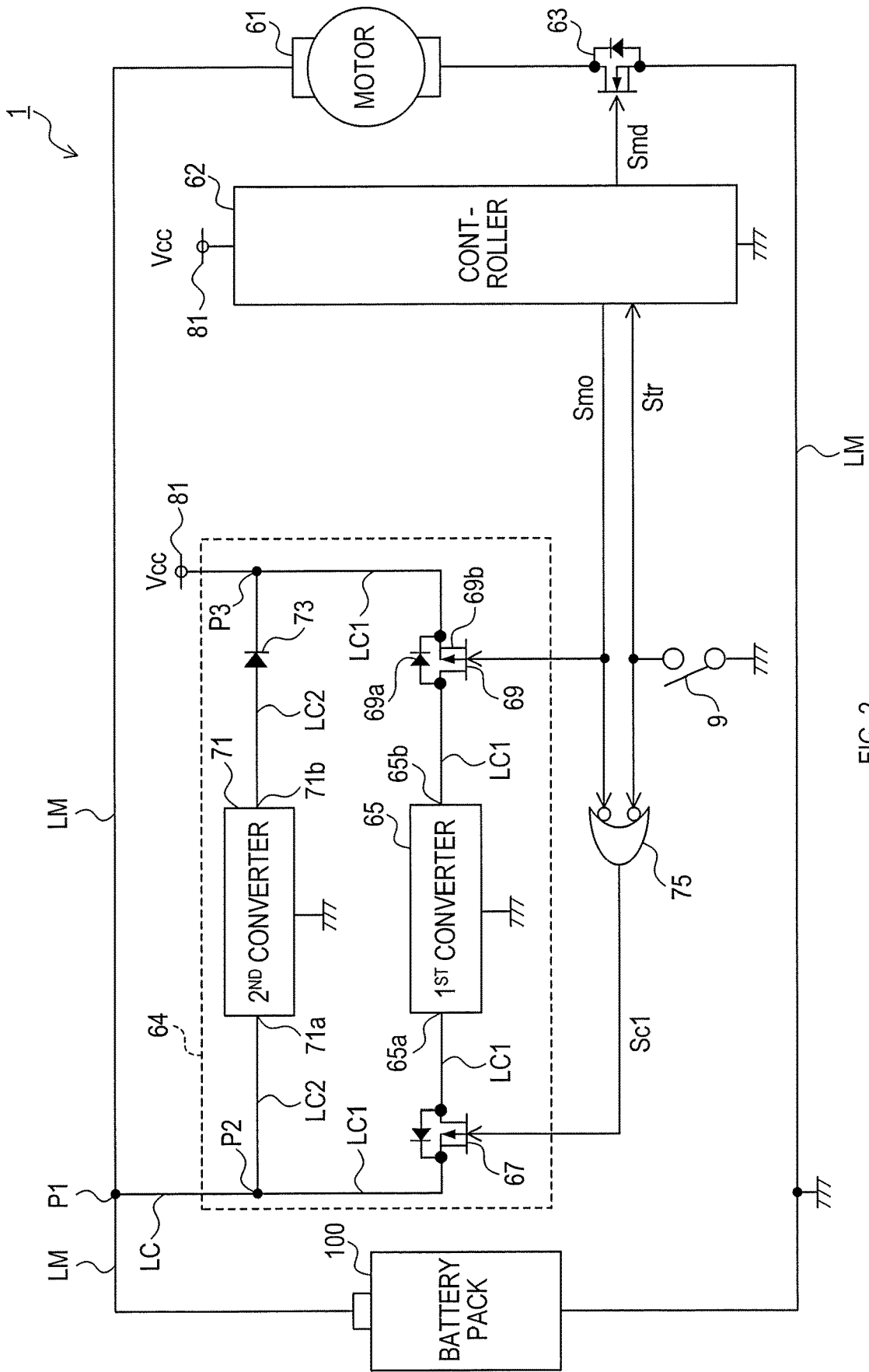

FIG. 2

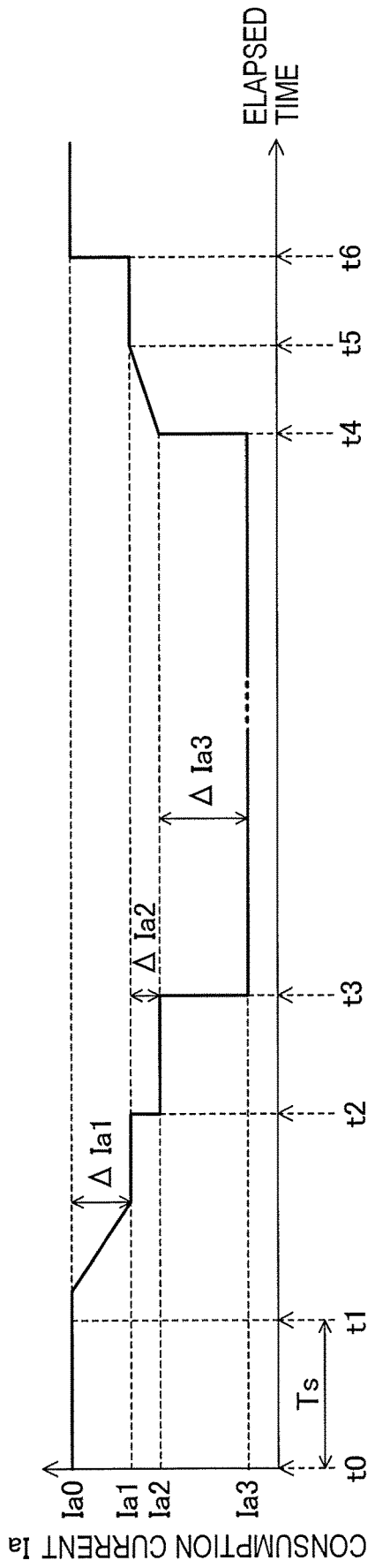

FIG. 3

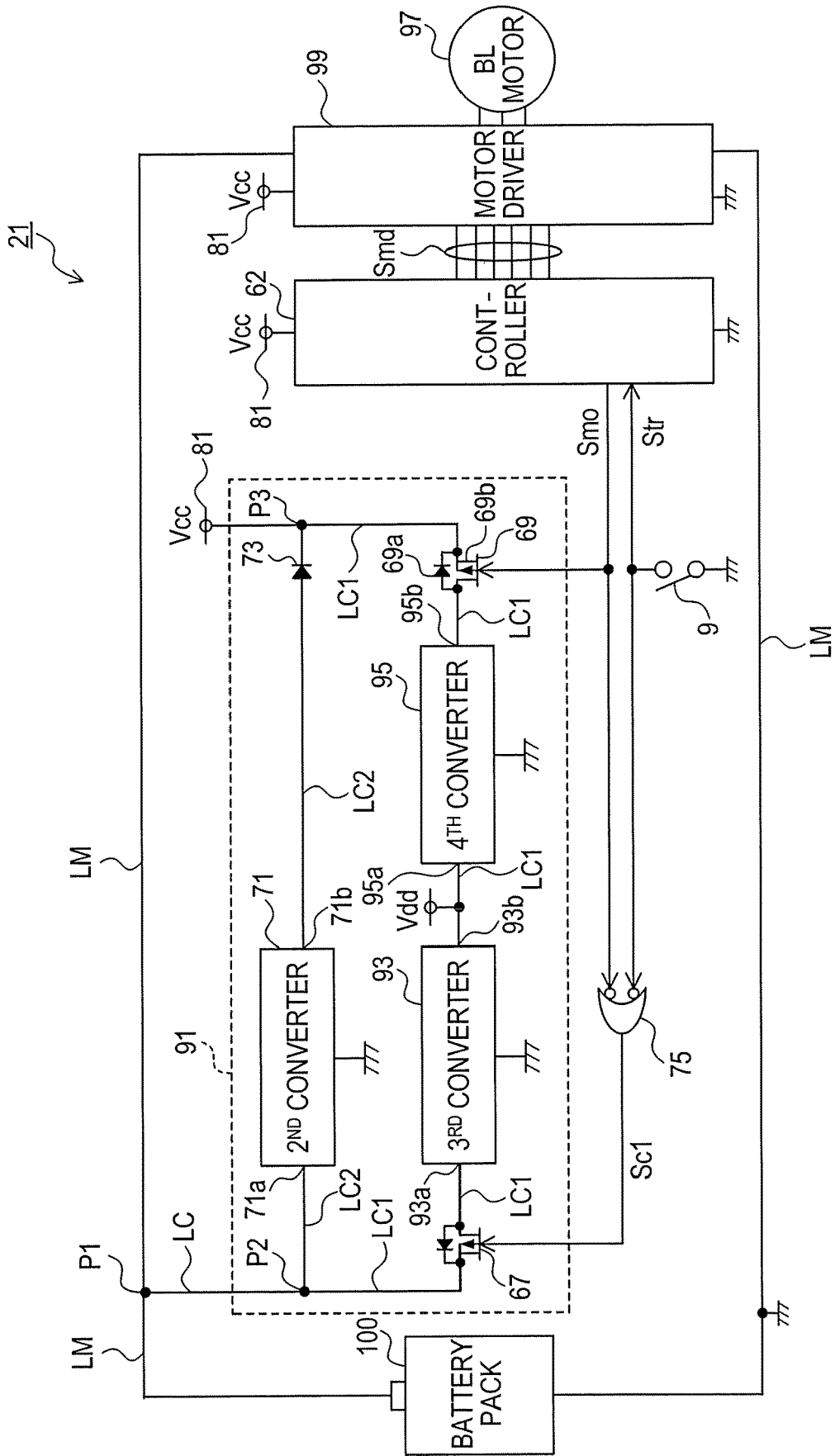

FIG. 4

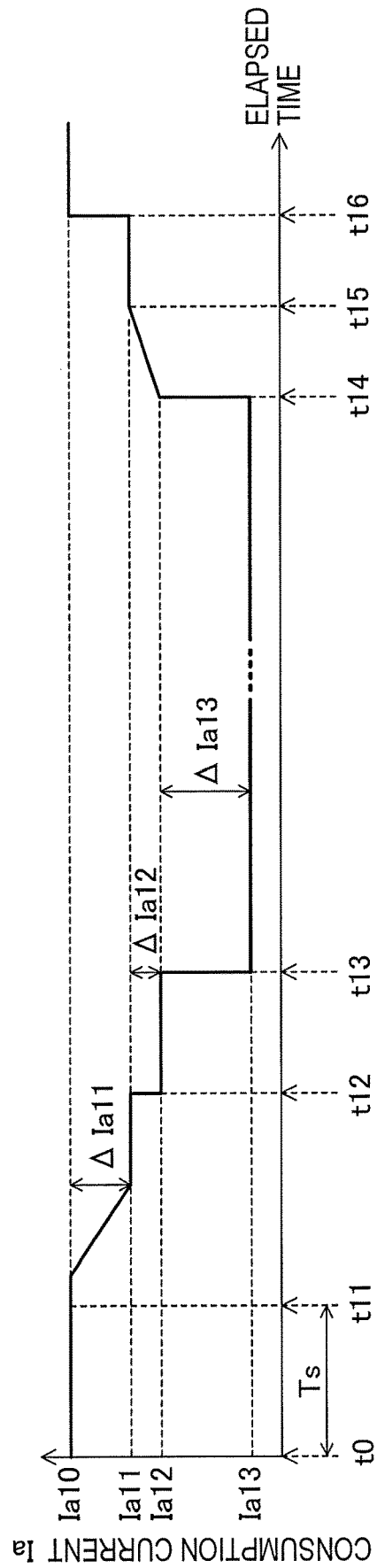

FIG. 5

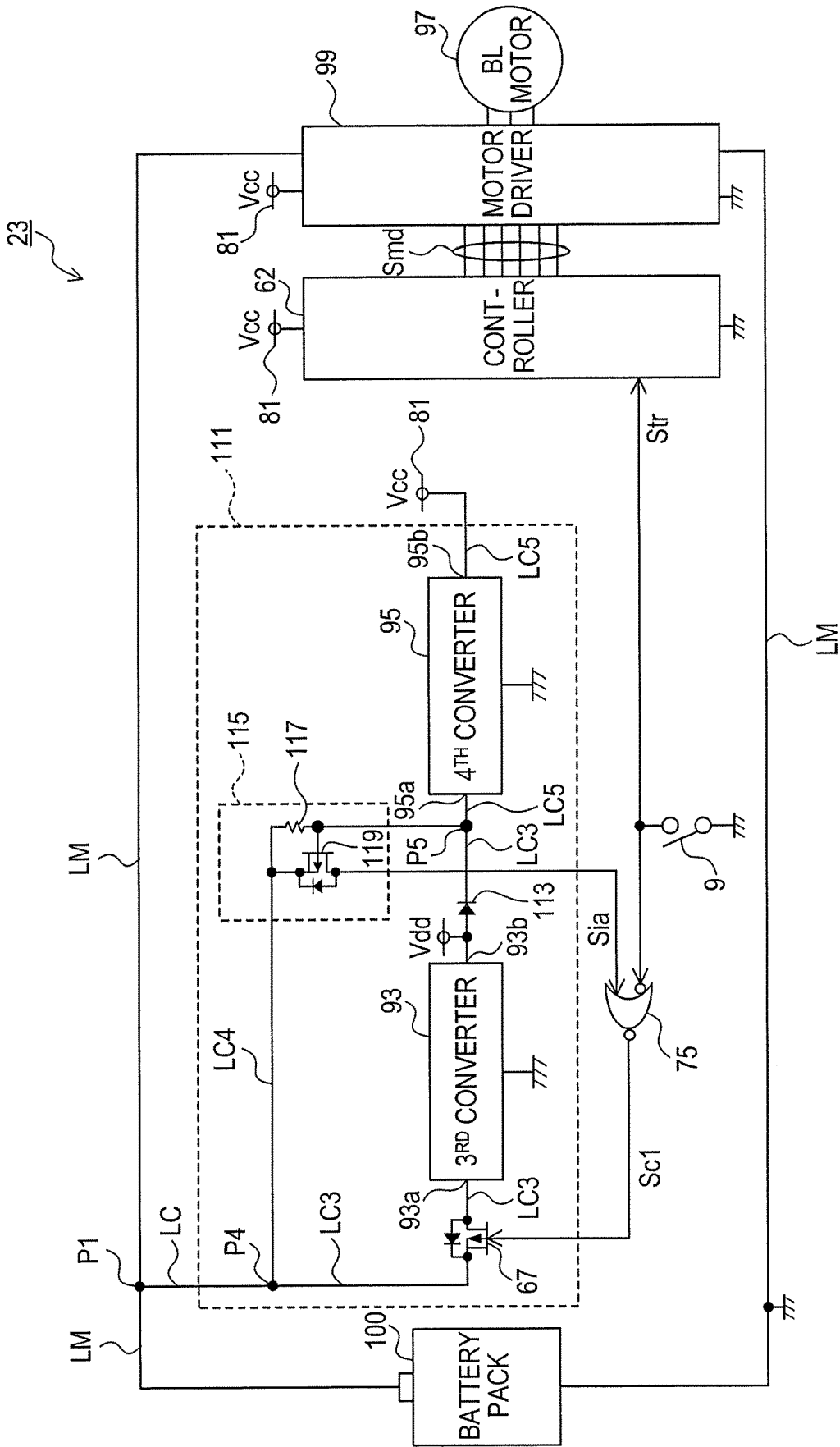

FIG. 6

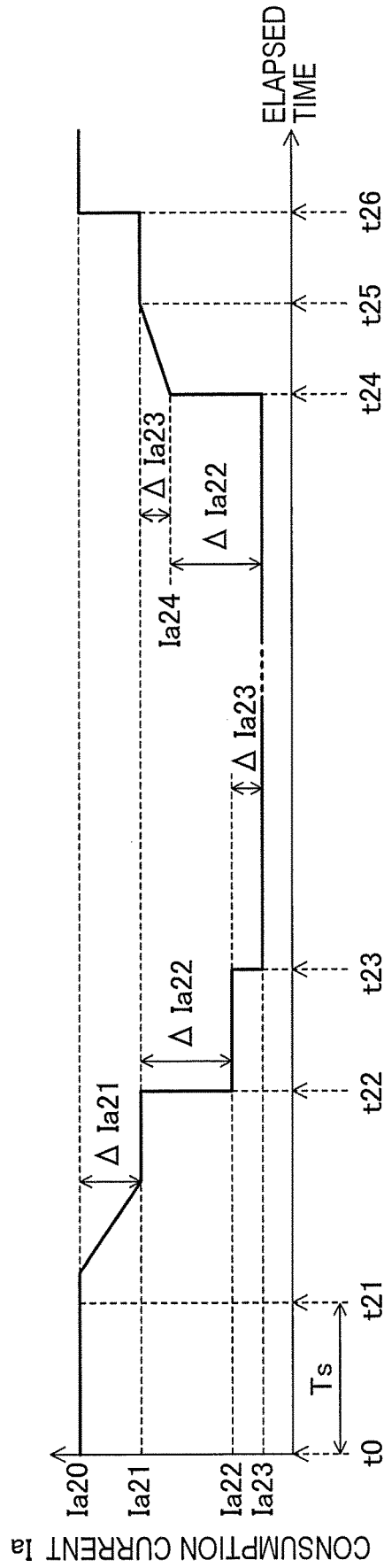

FIG. 7

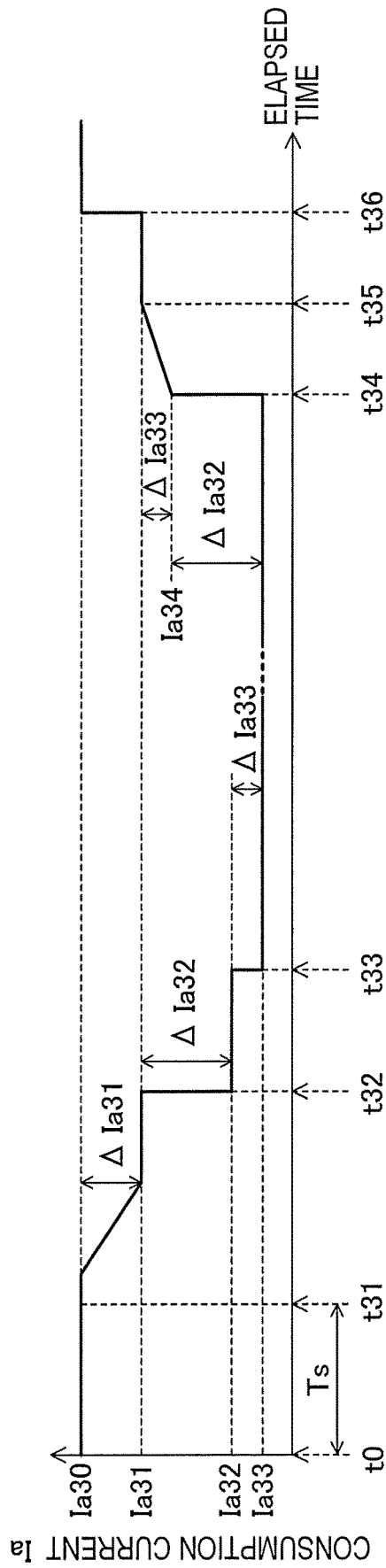

FIG. 9

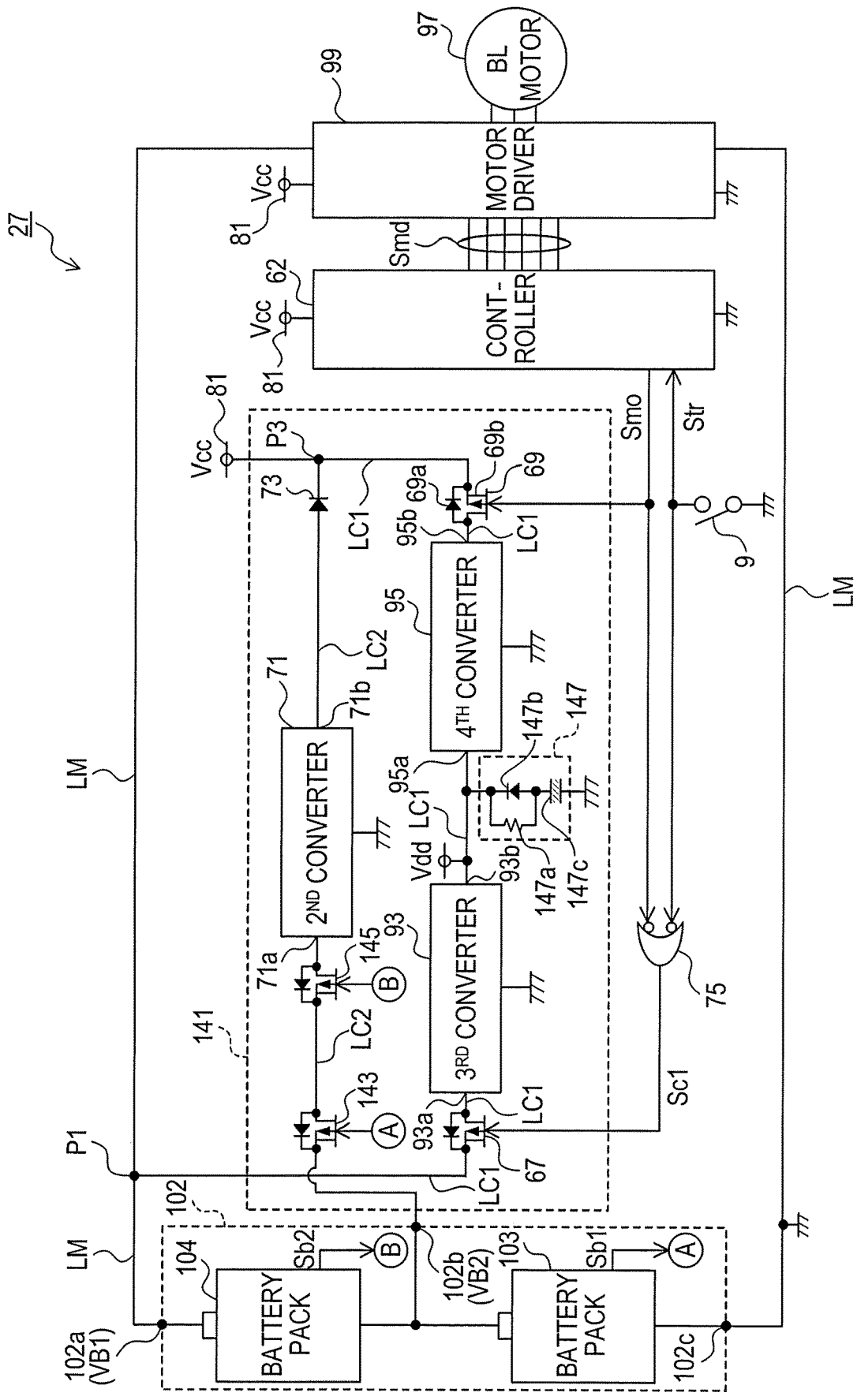

FIG. 10

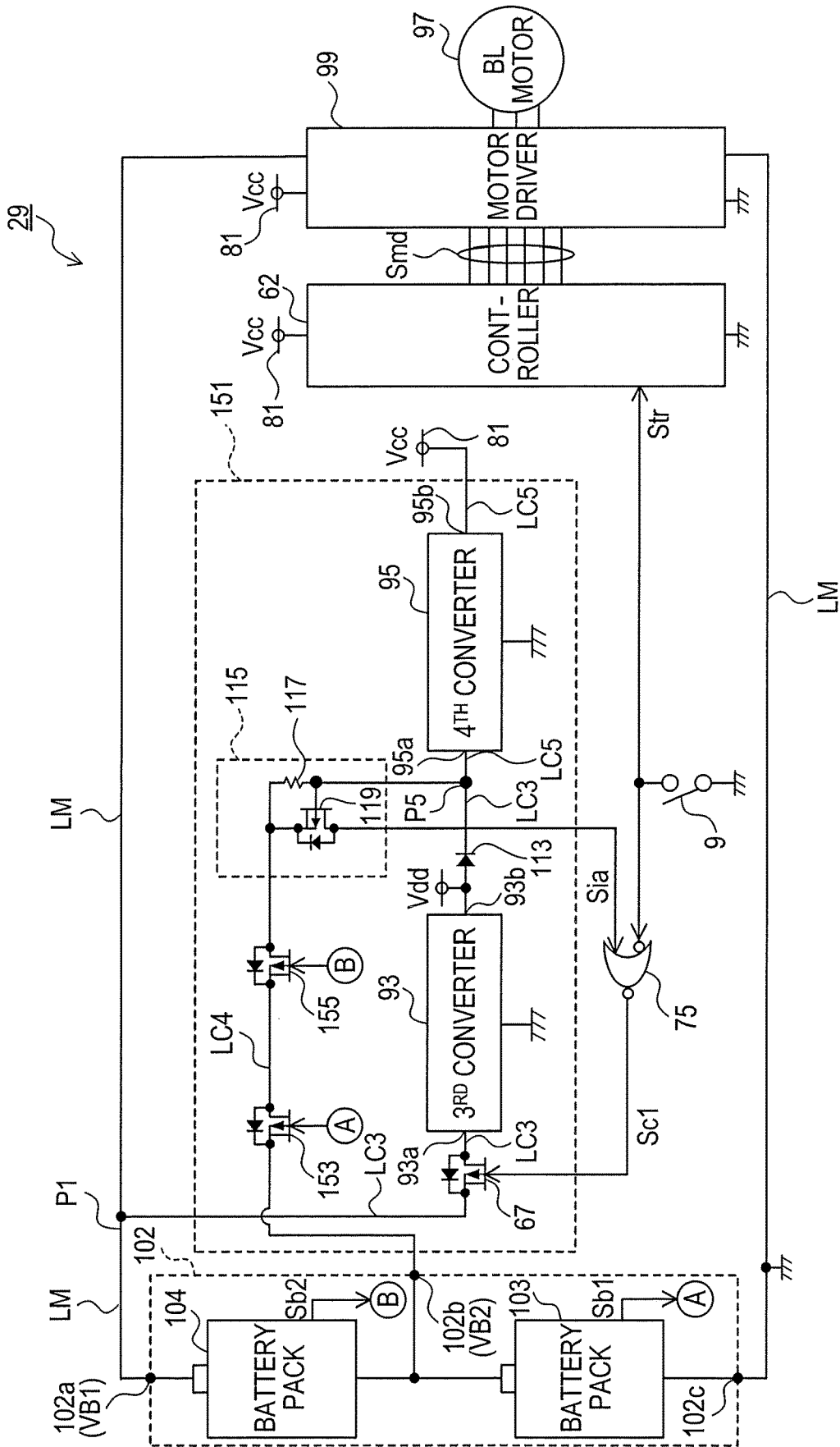

FIG. 11

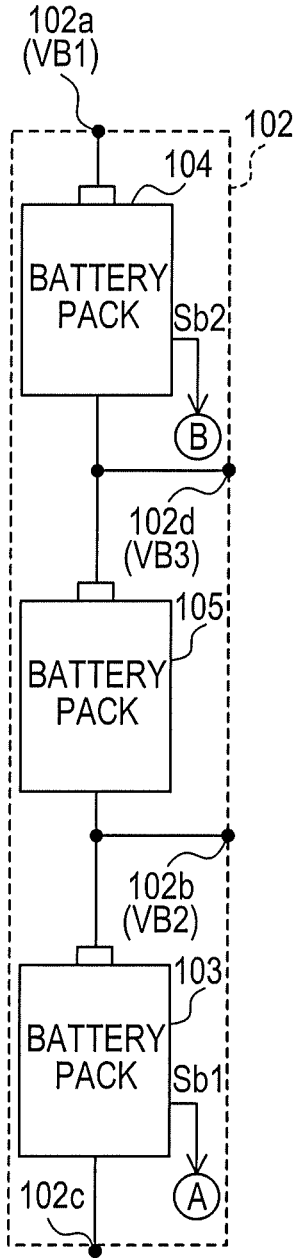

FIG. 12

**ELECTRIC WORKING MACHINE, AND
METHOD FOR SUPPLYING ELECTRIC
POWER TO CONTROLLER OF ELECTRIC
WORKING MACHINE**

CROSS-REFERENCE TO RELATED
APPLICATIONS

[0001] This application claims the benefit of Japanese Patent Applications No. 2019-075684 filed on Apr. 11, 2019 and No. 2019-105681 filed on Jun. 5, 2019 with the Japan Patent Office, the entire disclosures of which are incorporated herein by reference.

BACKGROUND

[0002] The present disclosure relates to an electric working machine.

[0003] Japanese Unexamined Patent Application Publication No. 2006-341325 discloses an electric working machine provided with a driving device that is driven by power supply from a battery (i.e. a power source). The electric working machine includes a controller that controls the driving device, and a control power source that supplies an electric power to the controller based on an electric power from the battery. Examples of the driving device includes a motor, a heater, etc. The electric working machine interrupts power supply from the control power source in order to suppress overdischarge of the battery when the electric working machine is not used. This allows the electric working machine to reduce power consumption in the controller or the control power source to zero (0).

[0004] In case that power supply from the control power source is interrupted, events as below may occur: (1) communications between the electric working machine and external devices becomes unavailable while the electric power is interrupted, and (2) a time lag occurs between re-manipulation of a trigger of the electric working machine and restart of the motor of the electric working machine so that feeling of use decreases.

[0005] In contrast, it is conceivable to transition the controller to a low power operation state (so-called sleep mode), instead of interrupting power supply from the control power source, while the electric working machine is not used. For example, it is conceivable to use a controller configured such that its operation state is transitioned to a control operation state or a low power operation state. In the control operation state, the driving device is controlled when the user manipulates the electric working machine. In the low power operation state, power consumption in the controller is reduced. In other words, this controller is configured to transition to the low power operation state in order to suppress overdischarge of the battery.

SUMMARY

[0006] In the aforementioned electric working machine, although power consumption in the controller can be reduced by transitioning the operation state of the controller to the low power operation state, there is a possibility that power consumption in the control power source cannot be reduced since the control power source performs a power conversion operation.

[0007] For example, in case that a linear regulator is used as the control power source, when an output voltage (power-supply voltage) of the battery increases, loss L_s ($=V_{in}$ -

V_{out}) $\times I_o$) in the linear regulator increases. V_{in} represents an input voltage (in other words, output voltage of the battery) to the linear regulator, V_{out} represents an output voltage from the regulator, and I_o represents an output current of the linear regulator. In other words, at the time of normal operation, as the power-supply voltage increases, power consumption due to the loss L_s occurs in the control power source.

[0008] In order to suppress increase in power consumption due to increase in power-supply voltage, a switching regulator such as a DC-DC converter may be used as the control power source. However, the switching regulator as such generally consumes a large operation current. Thus, even if the controller transitions to the sleep mode, it is difficult to reduce power consumption as a whole due to the large operation current of the switching regulator.

[0009] In other words, even if the controller transitions to the sleep mode while the electric working machine is not used, and power consumption in the controller can be reduced, electric power is consumed in the control power source, so that electric power of the battery (power source) is reduced.

[0010] In one aspect of the present disclosure, it is desirable that power consumption in an electric working machine can be reduced when the electric working machine is not used.

[0011] An electric working machine in one aspect of the present disclosure includes a driving device, a controller, an operation state determiner, a control power source, and/or an operation state determiner.

[0012] The driving device is driven with power-supply power from the power source.

[0013] The controller switches an operation state of the controller to one of multiple operation states. The multiple operation states include a control operation state and a low power operation state. The controller in the control operation state controls the driving device. The controller in the low power operation state consumes electric power smaller than power consumption of the controller in the control operation state.

[0014] The operation state determiner determines the operation state of the controller.

[0015] The control power source includes a first converter and a second converter. The first converter outputs a first control current based on the power-supply power. The first control current has a maximum value corresponding to a maximum consumption current value of the controller in the control operation state.

[0016] The second converter outputs a second control current based on the power-supply power. The second control current has a maximum value (i) smaller than the maximum value of the first control current and (ii) corresponding to a maximum consumption current value of the controller in the low power operation state.

[0017] Further, the control power source transitions to a first conversion state in response to the operation state determiner determining that the controller is in the control operation state. The control power source in the first conversion state supplies the first control current to the controller. The control power source transitions to the second conversion state in response to the operation state determiner determining that the controller is in the low power operation state. The control power source in the second

conversion state (i) stops operation of the first converter, and (ii) supplies the second control current to the controller.

[0018] The electric working machine can suppress power consumption in the first converter in order to stop operation of the first converter when the controller is in the low power operation state. Therefore, in case that the operation state of the controller is transitioned from the control operation state to the low power operation state when the electric working machine is not used, the electric working machine can reduce not only power consumption in the controller but also power consumption in the first converter. This allows the electric working machine to reduce power consumption when the electric working machine is not used.

[0019] The control power source may transition to the first conversion state in response to a user manipulating the electric working machine.

[0020] In other words, in case that the user manipulates the electric working machine when the control power source is in the second conversion state, the control power source transitions from the second conversion state to the first conversion state. As a result, the first control current is supplied to the controller at least by the first converter. This allows the controller to receive supply of the first control current required in the control operation state, and control the driving device. An example manipulation of the electric working machine by the user includes manipulation of a trigger switch by the user, etc.

[0021] The first converter may include a first outputter. The electric working machine may include a first reverse flow suppressor. The first reverse flow suppressor suppresses inflow of reverse current to the first outputter. The electric working machine can suppress inflow of the second control current to the first outputter. The first reverse flow suppressor may include a switching element such as a diode or FET coupled in series to the first outputter.

[0022] The control power source may include a first current path and a second current path. The first current path may be a part of a current path from the power source to the controller. The first converter may be provided in the first current path. The second current path may be coupled in parallel to the first current path. The second converter may be provided in the second current path.

[0023] The control power source in the first conversion state may supply the first control current to the controller via the first current path. The control power source in the second conversion state may supply the second control current to the controller via the second current path.

[0024] The electric working machine can suppress power consumption in the first converter when the controller is in the low power operation state, since the control power source transitions to the second conversion state, and stops power supply using the first converter. Thus, in case that the controller transitions from the control operation state to the low power operation state when the electric working machine is not used, the electric working machine can reduce not only power consumption in the controller but also power consumption in the first converter. As a result, the electric working machine can reduce power consumption when the electric working machine is not used.

[0025] The second converter may include a second outputter. The electric working machine may include a second reverse flow suppressor. The second reverse flow suppressor may be provided in the second current path between the

second converter and the controller. The second reverse flow suppressor may suppress inflow of reverse current to the second outputter.

[0026] The electric working machine as such can keep the first control current from flowing toward the second outputter as a reverse current. The second reverse flow suppressor may include a switching element such as a diode or FET coupled in series to the second converter.

[0027] The power source may output a power-supply voltage. The first converter may output a first control voltage based on the power-supply voltage. The first control voltage may be lower than the power-supply voltage. The second converter may output a second control voltage based on the power-supply voltage. The first control voltage may be approximately equal to the second control voltage. The electric working machine can keep applied voltage to the controller constant regardless of whether the first converter or the second converter is used. Thus, the electric working machine can suppress malfunction due to fluctuation in the applied voltage at the time of switching between the first converter and the second converter.

[0028] The operation state determiner may receive a first state notification signal and a second state notification signal. The operation state determiner may determine that the operation state of the controller is the control operation state in response to receipt of the first state notification signal. The operation state determiner may determine that the operation state of the controller is the low power operation state in response to receipt of the second state notification signal. The first state notification signal indicates that the operation state of the controller is the control operation state. The second state notification signal indicates that the operation state of the controller is the low power operation state. In the electric working machine, the operation state determiner can determine the operation state of the controller based on the first state notification signal and the second state notification signal.

[0029] The control power source may include a third current path, a bypass current path, and a common current path. The third current path may be a part of the current path from the power source to the controller. The first converter may be provided in the third current path. The bypass current path may be coupled in parallel to the third current path. The common current path may have a first end coupled to the third current path and the bypass current path. The second converter may be provided in the common current path.

[0030] The power source may output a power-supply voltage.

[0031] The first converter may convert the power-supply voltage to the first control voltage. The first control voltage may be lower than the power-supply voltage.

[0032] The second converter may convert the power-supply voltage or the first control voltage to the second control voltage. The second control voltage may be lower than the first control voltage.

[0033] The control power source in the first conversion state may operate the first converter and the second converter so that the second converter converts the first control voltage to the second control voltage. The control power source in the first conversion state may supply the second control voltage to the controller. The control power source in the first conversion state may operate the second converter so that the second converter converts the power-supply voltage to the second control voltage.

[0034] The electric working machine can suppress power consumption in the first converter when the controller is in the low power operation state, since the control power source transitions to the second conversion state and stops operation of the first converter. Therefore, in case that the controller transitions from the control operation state to the low power operation state when the electric working machine is not used, the electric working machine can reduce not only power consumption in the controller but also power consumption in the first converter. This allows the electric working machine to reduce power consumption when the electric working machine is not used.

[0035] The bypass current path may receive a bypass current. The operation state determiner may determine whether a value of the bypass current flowing through the bypass current path is larger than a predefined operation reference value. Further, the operation state determiner may determine that the controller is in the control operation state in response to the value of the bypass current being larger than the operation reference value. Further, the operation state determiner may determine that the controller is in the low power operation state in response to the value of the bypass current being equal to or smaller than the operation reference value. The operation state determiner can determine the operation state of the controller based on a result of comparison between the bypass current and the operation reference value.

[0036] The operation state determiner may receive the first state notification signal and the second state notification signal. The operation state determiner may determine that the controller is in the control operation state in response to the value of the bypass current being larger than the operation reference value or in response to receipt of the first state notification signal. The operation state determiner may determine that the controller is in the low power operation state (i) in response to the value of the bypass current being equal to or smaller than the operation reference value and (ii) in response to receipt of the second state notification signal. The first state notification signal indicates that the operation state of the controller is the control operation state. The second state notification signal indicates that the operation state of the controller is the low power operation state. The operation state determiner can determine the operation state of the controller based on the first state notification signal and the second state notification signal, in addition to the result of comparison between the bypass current and the operation reference value.

[0037] The power source may include a first voltage outputter and a second voltage outputter. The first converter may be coupled to the first voltage outputter. The second converter may be couple to the second voltage outputter.

[0038] In other words, the power source can change a maximum output voltage by employing different configurations for an output voltage of the first voltage outputter and an output voltage of the second voltage outputter. This allows the electric working machine to operate an increased output based on the increased power-supply voltage.

[0039] The electric working machine as such stops operation of the first converter when the controller is in the low power operation state. Thus, the electric working machine can suppress power consumption in the first converter, and can reduce power consumption when the electric working machine is not used.

[0040] The first voltage outputter may output a first output voltage. The second voltage outputter may output a second output voltage. The first output voltage may be higher than the second output voltage. As a result, electric energy that can be outputted from the first converter is larger than electric energy that can be outputted from the second converter. Thus, the first converter, as compared to the second converter, can supply sufficient electric power to the controller. This can reduce voltage change for voltage conversion in the second converter, and reduce power loss due to voltage conversion as compared to a case of large voltage change.

[0041] The power source may further include a third voltage outputter. The third voltage outputter may output a third output voltage. The second output voltage may be lower than the third output voltage. In other words, the second voltage outputter outputs a voltage lower than those of the first voltage outputter and the third voltage outputter. This can reduce voltage change for voltage conversion in the second converter, and reduce power loss due to power conversion as compared to a case of large voltage change.

[0042] Another aspect of the present disclosure provides a method for supplying electric power to a controller in an electric working machine. The method includes supplying a first control current from a first converter to the controller in response to the controller being in a control operation state, and/or supplying a second control current from a second converter to the controller in response to the controller being in a low power operation state. The first converter is configured to output the first control current based on power-supply power of the electric working machine. The first control current has a maximum value corresponding to a maximum consumption current value of the controller in the control operation state. The second converter is configured to output the second control current based on the power-supply power. The second control current has a maximum value (i) smaller than the maximum value of the first control current and (ii) corresponding to a maximum consumption current value of the controller in the low power operation state.

BRIEF DESCRIPTION OF THE DRAWINGS

[0043] Exemplary embodiments of the present disclosure will be described hereinafter with reference to the accompanying drawings, in which:

[0044] FIG. 1 is a perspective view of an electric working machine of embodiments;

[0045] FIG. 2 is a block diagram showing an electrical configuration of the electric working machine in a first embodiment;

[0046] FIG. 3 is a timing chart showing a relationship between switching of operation state of a controller and consumption current in a control power source, in the first embodiment;

[0047] FIG. 4 is a block diagram showing an electrical configuration of the electric working machine in a second embodiment;

[0048] FIG. 5 is a timing chart showing a relationship between switching of operation state of the controller and consumption current in a second control power source, in the second embodiment;

[0049] FIG. 6 is a block diagram showing an electrical configuration of the electric working machine in a third embodiment;

[0050] FIG. 7 is a timing chart showing a relationship between switching of operation state of the controller and consumption current in a third control power source, in the third embodiment;

[0051] FIG. 8 is a block diagram showing an electrical configuration of the electric working machine in a fourth embodiment;

[0052] FIG. 9 is a timing chart showing a relationship between switching of operation state of the controller and consumption current in a fourth control power source, in the fourth embodiment;

[0053] FIG. 10 is a block diagram showing an electrical configuration of the electric working machine in a fifth embodiment;

[0054] FIG. 11 is a block diagram showing an electrical configuration of the electric working machine in a sixth embodiment; and

[0055] FIG. 12 is a block diagram showing an electrical configuration of a multiple-output power source including three voltage outputters.

DETAILED DESCRIPTION OF EXEMPLARY EMBODIMENTS

1. First Embodiment

1-1. Overall Configuration

[0056] As shown in FIG. 1, an electric working machine 1 is configured as a rechargeable impact driver, for example. The rechargeable impact driver is driven with electric power supplied from a later-described battery pack 100. The rechargeable impact driver is used to rotate a fastening member such as a screw, a bolt and the like. The rechargeable impact driver is configured to apply hammering in a rotation direction in accordance with a load at the time of rotating the fastening member, thereby generating a large torque in the rotation direction.

[0057] As shown in FIG. 1, the electric working machine 1 of the present embodiment includes a main body 2 and the battery pack 100. The battery pack 100 is configured to be attached to and detached from the main body 2.

[0058] The main body 2 includes a housing 3. The housing 3 includes two half housings 3a, 3b divided into right and left. These half housings 3a, 3b are combined to form the housing 3. The housing 3 may be, for example, an injection molded member including resin.

[0059] The main body 2 includes a first storage 5, a grip 6, and a second storage 7. The first storage 5 is provided with a chuck sleeve 8, a LED 10, and a rotation direction switching manipulator 11. The LED 10 emits light to outside of the electric working machine 1. The grip 6 extends from the first storage 5. The second storage 7 extends from the grip 6. The second storage 7 is provided with a battery port 7a to and from which the battery pack 100 is attached and detached.

[0060] The battery pack 100 includes a rechargeable battery (not shown) that can be repeatedly charged and discharged. The rechargeable battery, for example, may be a lithium-ion battery, or may be a different type of rechargeable battery than lithium-ion battery. The battery pack 100 has an output voltage VB (hereinafter, battery voltage VB) of 36 [V].

[0061] The grip 6 is gripped by a user of the electric working machine 1 when the user uses the electric working

machine 1. The grip 6 is provided with a trigger manipulator 9. The user, while gripping the grip 6, can perform a pulling operation of the trigger manipulator 9 (trigger ON manipulation) by a finger.

1-2. Electrical Configuration of Electric Working Machine

[0062] FIG. 2 shows an electrical configuration of the electric working machine 1 with the battery pack 100 attached to the main body 2.

[0063] As shown in FIG. 2, the electric working machine 1 includes a motor 61, a controller 62, a motor driver 63, a control power source 64, and an operation state determiner 75. The electric working machine 1 includes a motor conduction path LM, a voltage conversion path LC, a first current path LC1, and a second current path LC2.

[0064] The motor conduction path LM is a current path from a positive electrode of the battery pack 100 to a negative electrode of the battery pack 100 via the motor 61 and the motor driver 63. A first end of the voltage conversion path LC is coupled to a first junction P1 of the motor conduction path LM, and a second end of the voltage conversion path LC is coupled to the control power source 64 (second junction P2 in detail). The first current path LC1 and the second current path LC2 are provided in the control power source 64.

[0065] The motor 61 is a brushed motor. The motor 61 is driven by current conduction using electric power supplied from the battery pack 100 via the motor conduction path LM.

[0066] The motor driver 63 is provided with a switcher (such as a FET) coupled in series to the motor conduction path LM. The motor driver 63 is configured to switch the switcher to a conduction state (ON state) or a non-conduction state (OFF state), and switch the motor conduction path LM to a conduction state or a non-conduction state, based on a motor drive command Smd from the controller 62.

[0067] The controller 62 includes a microcomputer provided with a CPU, memory devices (ROM and RAM), a signal I/O, etc. The controller 62 receives power supply via a later-described constant voltage supply line 81. The controller 62 executes various processes as the CPU executes various programs stored in the recorders. Examples of various processes include a motor control process to control the motor 61 by the motor drive command Smd, a failure determination process to determine whether there is failure in the electric working machine 1, an operation state switching process to selectively switch operation state of the controller 62 to one of multiple operation states, etc.

[0068] The operation state at least includes a control operation state and a low power operation state. The control operation state is a state in which the motor control process, the failure determination process, etc. can be executed. In the control operation state, the controller 62 performs A-D conversion of measurement signals from various sensors (not shown) that measure states (motor temperature, motor current, etc.) of each part of the electric working machine 1 and executes the failure determination process, etc. In case of the control operation state, a constant voltage Vcc supplied from the constant voltage supply line 81 is a reference voltage for A-D conversion. Therefore, high voltage accuracy is required so that voltage error can be reduced. The low power operation state has lower power consumption than the control operation state. The low power operation state is a

so-called sleep state in which power consumption in the controller 62 is reduced. In the low power operation state, the controller 62 does not execute A-D conversion, etc., and does not perform comparison processes between the reference voltage (constant voltage Vcc) and measurement signals from various sensors. In case of the low power operation state, the constant voltage Vcc supplied from the constant voltage supply line 81 is not used as the reference voltage for A-D conversion. Therefore, required voltage accuracy is lower than that in the control operation state. A maximum consumption current value of the controller 62 in the control operation state (first control current value ICmax) is 100 mA, and a maximum consumption current value of the controller 62 in the low power operation state (second control current value ISmax) is 50 μ A.

[0069] The controller 62 is configured to transition the operation state of the controller 62 from the control operation state to the low power operation state when the user does not perform manipulation (such as manipulation of the trigger manipulator 9) for a predefined sleep determination time Ts (5 mins, for example).

[0070] The controller 62 is configured to output a state notification signal Smo corresponding to the operation state in execution. In other words, the controller 62 outputs the state notification signal Smo indicating the control operation state (hereinafter, first state notification signal Smo1) when the operation state is transitioned to the control operation state, and outputs the state notification signal Smo indicating the low power operation state (hereinafter, second state notification signal Smo2) when the operation state is transitioned to the low power operation state. The controller 62 outputs the state notification signal Smo at least to the control power source 64 (later-described first reverse flow suppressor 69 in detail) and the operation state determiner 75.

[0071] The trigger manipulator 9 is configured to output a trigger signal Str when the user performs the pulling operation. The trigger manipulator 9 is configured to output the trigger signal Str having the same potential as a ground potential during execution of the pulling operation by the user. The trigger signal Str is outputted at least to the controller 62 and the operation state determiner 75.

[0072] The operation state determiner 75 is configured to determine whether the operation state of the controller 62 is the control operation state or the low power operation state. The operation state determiner 75 is configured to receive the state notification signal Smo and the trigger signal Str, and output a conduction command signal Sc1 in accordance with each state of the state notification signal Smo and the trigger signal Str.

[0073] The operation state determiner 75 is configured to determine that the controller 62 is in the control operation state when the first state notification signal Smo1 or the trigger signal Str is received (in other words, during execution of the pulling operation by the user). The operation state determiner 75 is configured to determine that the controller 62 is in the low power operation state when the second state notification signal Smo2 is received and the trigger signal Str is not received (in other words, the pulling operation by the user is not executed). The operation state determiner 75 is configured to output the conduction command signal Sc1 corresponding to a determination result.

1-3. Control Power Source

[0074] The control power source 64 converts the battery voltage VB from the battery pack 100 to the constant voltage Vcc, and outputs the constant voltage Vcc to the constant voltage supply line 81. The constant voltage Vcc is supplied to each component (such as the controller 62) of the electric working machine 1 via the constant voltage supply line 81. In the present embodiment, the constant voltage Vcc is 5 [V]. Electric power supplied from the control power source 64 via the constant voltage supply line 81 is used for operation of the controller 62, for example.

[0075] The control power source 64 includes a first converter 65, a first switcher 67, the first reverse flow suppressor 69, a second converter 71, a second reverse flow suppressor 73, the first current path LC1, and the second current path LC2.

[0076] The first current path LC1 is a part of a current path from the battery pack 100 to the controller 62, and is provided with the first converter 65. The second current path LC2 is coupled in parallel to the first current path LC1, and is provided with the second converter 71. A first end of the first current path LC1 and a first end of the second current path LC2 are coupled to the second junction P2 and the voltage conversion path LC. A second end of the first current path LC1 and a second end of the second current path LC2 are coupled to a third junction P3 and the constant voltage supply line 81.

[0077] The first switcher 67, the first converter 65, and the first reverse flow suppressor 69 are arranged in this order from the second junction P2 to the third junction P3 in the first current path LC1.

[0078] The first converter 65 includes a DC-DC converter that converts direct voltage and outputs a resulting voltage. The first converter 65 converts the battery voltage VB inputted to the input device 65a to the constant voltage Vcc, and outputs the constant voltage Vcc through a first outputter 65b. The first converter 65 outputs 5 [V] as the constant voltage Vcc. The constant voltage Vcc is supplied to each component (such as the controller 62) of the electric working machine 1 via the constant voltage supply line 81. The first converter 65 has a performance of 100 mA or more in maximum output current for voltage conversion, and is configured to supply the maximum consumption current value of the controller 62 in the control operation state (first control current value ICmax). Power consumption required for voltage conversion in the first converter 65 corresponds to consumption current in mA order.

[0079] The first switcher 67 is provided in the first current path LC1 between the second junction P2 and the first converter 65. The first switcher 67 is provided with a switcher (such as a FET) coupled in series to the first current path LC1. The first switcher 67 is configured to switch the switcher to a conduction state (ON state) or a non-conduction state (OFF state) based on the conduction command signal Sc1 from the operation state determiner 75. The first switcher 67 is configured to switch electric conduction of the first current path LC1 from the second junction P2 to the first converter 65 to a conduction state or a non-conduction state. This allows the first switcher 67 to switch an input state of the battery voltage VB to the first converter 65 based on the conduction command signal Sc1.

[0080] The first reverse flow suppressor 69 is provided in the first current path LC1 between the first converter 65 and the third junction P3. The first reverse flow suppressor 69

includes a diode **69a** coupled in series to the first current path **LC1**, and a switcher **69b** in parallel with the diode **69a**. The diode **69a** allows electric conduction from the first converter **65** to the third junction **P3**, and suppresses electric conduction from the third junction **P3** to the first converter **65**. In case that the switcher **69b** is a FET, a parasitic diode always present in the FET may be used as the diode **69a**. The first reverse flow suppressor **69** is configured to switch the switcher **69a** to a conduction state (ON state) or a non-conduction state (OFF state) and switch the first current path **LC1** to a conduction state or a non-conduction state based on the state notification signal **Smo** from the controller **62**.

[0081] As a result, when the switcher **69b** enters the non-conduction state, the first reverse flow suppressor **69** allows current conduction from the first outputter **65b** of the first converter **65** to the constant voltage supply line **81** via the diode **69a**, and suppresses inflow of reverse current from the third junction **P3** to the first outputter **65b** of the first converter **65**. At the time of current conduction from the first outputter **65b** to the constant voltage supply line **81** via the diode **69a**, the constant voltage **Vcc** outputted from the first outputter **65b** drops by a forward voltage (**Vf**) of the diode **69a** and is outputted to the constant voltage supply line **81**. Also, in the first reverse flow suppressor **69**, when the switcher **69b** enters the conduction state, the constant voltage **Vcc** outputted from the first outputter **65b** of the first converter **65** does not drop at the diode **69a** and is outputted to the constant voltage supply line **81**.

[0082] The second converter **71** and the second reverse flow suppressor **73** are arranged in this order in the second current path **LC2** from the second junction **P2** to the third junction **P3**.

[0083] The second converter **71** includes a series regulator that converts direct voltage and outputs a resulting voltage. The second converter **71** converts the battery voltage **VB** inputted to the input device **71a** to the constant voltage **Vcc**, and outputs the constant voltage **Vcc** through a second outputter **71b**. The second converter **71** outputs **5 [V]** as the constant voltage **Vcc**. The constant voltage **Vcc** is supplied to each component (such as the controller **62**) of the electric working machine **1** via the constant voltage supply line **81**. The second converter **71** has a performance of **50 μ A** or more in maximum output current for voltage conversion, and is configured to supply the maximum consumption current value of the controller **62** in the low power operation state (second control current value **ISmax**). Power consumption required for voltage conversion in the second converter **71** corresponds to consumption current in μ A order. The second converter **71** has smaller maximum output current than the first control current value **ICmax**, and thus has smaller power consumption required for voltage conversion than the first converter **65**.

[0084] The second reverse flow suppressor **73** is provided in the second current path **LC2** between the second converter **71** and the third junction **P3**. The second reverse flow suppressor **73** includes a diode coupled in series to the second current path **LC2**. This diode is arranged to allow electric conduction from the second converter **71** to the third junction **P3** and suppress electric conduction from the third junction **P3** to the second converter **71**. Thus, the second reverse flow suppressor **73** allows output of voltage dropped from the constant voltage **Vcc** by the forward voltage (**Vf**) of the diode from the second outputter **71b** of the second converter **71** to the constant voltage supply line **81**, and

suppresses inflow of reverse current from the third junction **P3** to the second outputter **71b** of the second converter **71**.

[0085] The control power source **64** configured as above outputs the constant voltage **Vcc** using the first converter **65** and the second converter **71** when receiving the conduction command signal **Sc1** indicating the control operation state from the operation state determiner **75**, thereby transitioning to a state in which control power is supplied to the controller **62** (hereinafter, first conversion state).

[0086] Also, the control power source **64** stops voltage conversion by the first converter **65** and outputs the constant voltage **Vcc** using the second converter **71** when receiving the conduction command signal **Sc1** indicating the low power operation state from the operation state determiner **75**, thereby transitioning to a state in which control power is supplied to the controller **62** (hereinafter, second conversion state).

1-4. Change in Consumption Current Due to Switching of Operation State in Controller

[0087] Change in the consumption current **Ia** in the control power source **64** due to switching of the operation state of the controller **62** will be described with reference to FIG. 3.

[0088] FIG. 3 shows switching of the operation state of the controller **62** and change in consumption current due to elapse of time with time **t0** as time when the user has ended the pulling operation of the trigger manipulator **9**.

[0089] During a period from time **t0** to time **t1** when the sleep determination time **Ts** has elapsed, when a state continues in which the user does not perform the pulling operation of the trigger manipulator **9**, the controller **62** starts a process to transition the operation state (operation state switching process) from the control operation state to the low power operation state.

[0090] The controller **62**, when starting the operation state switching process, first executes a process to sequentially stop power supply to various devices and various circuits provided in the electric working machine **1**. Along with this, the consumption current **Ia** gradually decreases from an initial consumption current **IA0** (time **t1** to **t2**), and electric current equivalent to current consumption (first current variation $\Delta Ia1$) in various devices before stopping is reduced. The consumption current **Ia** at this time decreases to the first consumption current **Ia1**.

[0091] The controller **62** then executes a process to output the state notification signal **Smo** indicating the low power operation state, as one step of the operation state switching process (time **t2**). As a result, voltage conversion by the first converter **65** is stopped, and electric current equivalent to current consumption (second current variation $\Delta Ia2$) required for voltage conversion in the first converter **65** is reduced. The consumption current **Ia** at this time decreases to the second consumption current **Ia2**.

[0092] The controller **62** then executes a process to transition the controller **62** itself to the low power operation state (sleep mode), as a first step in the operation state switching process (time **t3**). As a result, electric current equivalent to current consumption (third current variation $\Delta Ia3$) corresponding to a difference between current consumption in the control operation state and current consumption in the low power operation state of the controller **62** is reduced, and the consumption current **Ia** at this time decreases to a third consumption current **Ia3**.

[0093] By executing these steps, the controller 62 completes the operation state switching process and maintains the low power operation state until the user performs the pulling operation of the trigger manipulator 9.

[0094] Thereafter, when the user performs the pulling operation of the trigger manipulator 9 (time t_4), the trigger signal Str is inputted to the controller 62. As a result, the controller 62 itself transitions to the control operation state (wakes up) from the low power operation state (sleep mode). The controller 62 that has waken up starts the operation state switching process to transition the operation state from the low power operation state to the control operation state. Also, when the trigger signal Str from the trigger manipulator 9 is inputted also to the operation state determiner 75, and the conduction command signal Sc1 from the operation state determiner 75 is inputted to the control power source 64, voltage conversion by the first converter 65 is started. Accordingly, along with wake-up of the controller 62 and the voltage conversion operation by the first converter 65, the consumption current I_a gradually increases to the first consumption current I_{a1} (time t_4 to t_5).

[0095] The controller 62 then executes a process to output a state notification signal Smo (first state notification signal Smo1) indicating the control operation state, as one step of the operation state switching process (time t_5). As a result, the constant voltage Vcc outputted from the first outputter 65b of the first converter 65 is supplied to the constant voltage supply line 81 without voltage drop.

[0096] The controller 62 then executes a process to sequentially start power supply to various devices and various circuits provided in the electric working machine 1, as one step of the operation state switching process (time t_6). Along with this, the consumption current I_a increases to the initial consumption current I_{a0} .

[0097] As above, in case that the operation state of the controller 62 is transitioned to the low power operation state, the electric working machine 1 of the present embodiment can stop voltage conversion in the first converter 65 to reduce the consumption current I_a equivalent to the second current variation ΔI_{a2} .

1-5. Effect

[0098] As described above, in the electric working machine 1 of the present embodiment, in case that the controller 62 is in the low power operation state, the control power source 64 transitions to the second conversion state, and the first converter 65 is not used for voltage conversion in the control power source 64. Thus, power consumption in the first converter 65 can be suppressed. As a result, in case that the operation state of the controller 62 is transitioned from the control operation state to the low power operation state when the electric working machine 1 is not used, not only power consumption in the controller 62 but also power consumption in the first converter 65 can be reduced. Thus, power consumption when the electric working machine 1 is not used can be reduced.

[0099] In the electric working machine 1, the control power source 64 is configured to transition to the operation state to the first conversion state when the electric working machine 1 is manipulated (for example, the pulling operation of the trigger manipulator 9, etc.) by the user. In other words, in case that the trigger manipulator 9 is manipulated by the user when the operation state of the control power source 64 is the second conversion state, the control power

source 64 transitions the operation state of the control power source 64 from the second conversion state to the first conversion state. As a result, since at least the first converter 65 supplies the constant voltage Vcc, the controller 62 can receive supply of the first control current value I_{Cmax} required in the control operation state, and control the motor 61.

[0100] The electric working machine 1 includes the first reverse flow suppressor 69. Therefore, inflow of reverse current to the first outputter 65b of the first converter 65 can be suppressed. As a result, the electric working machine 1 can suppress inflow of electric current outputted from the second converter 71 to the first outputter 65b of the first converter 65 via the third junction P3 by the first reverse flow suppressor 69.

[0101] The electric working machine 1 includes the second reverse flow suppressor 73. Therefore, inflow of reverse current to the second outputter 71b of the second converter 71 can be suppressed. As a result, the electric working machine 1 can suppress inflow of electric current outputted from the first converter 65 to the second outputter 71b of the second converter 71 via the third junction P3 by the second reverse flow suppressor 73.

[0102] In the electric working machine 1, the output voltage (constant voltage Vcc=5 [V]) of the first converter 65 and the output voltage (constant voltage Vcc=5 [V]) of the second converter 71 have the same voltage value, and the first reverse flow suppressor 69 is provided with the switcher 69b in parallel with the diode 69a and the second reverse flow suppressor 73 includes a diode. Thus, in case that the controller 62 enters the control operation state and both the first converter 65 and the second converter 71 output voltage, as well as the switcher 69b is ON, the voltage outputted from the first converter 65 to the constant voltage supply line 81 and the voltage outputted from the second converter 71 to the constant voltage supply line 81 via the second reverse flow suppressor 73 have different values. Specifically, in case that the controller 62 is in the control operation state, the voltage outputted from the first converter 65 to the constant voltage supply line 81 is the constant voltage Vcc while the voltage outputted from the second converter 71 to the constant voltage supply line 81 via the second reverse flow suppressor 73 is a voltage dropped from the constant voltage Vcc by the forward voltage (Vf) of the diode. Accordingly, in case that the controller 62 is in the control operation state, only the voltage outputted from the first converter 65 is supplied to the controller 62. Thus, it is possible to refrain from supplying the maximum consumption current value of the controller 62 from the second converter 71 having no supply capacity.

[0103] In the electric working machine 1, the operation state determiner 75 is configured to receive the first state notification signal Smo1 and the second state notification signal Smo2. The operation state determiner 75, when receiving the first state notification signal Smo1, determines that the operation state of the controller 62 is the control operation state, and, when receiving the second state notification signal Smo2, determines that the operation state of the controller 62 is the low power operation state. In other words, the operation state determiner 75 can determine the operation state of the controller 62 based on the first state notification signal Smo1 and the second state notification signal Smo2.

1-6. Correspondence Relationship Between Terms

[0104] The motor **61** corresponds to one example of a driving device, and the battery pack **100** corresponds to one example of a power source.

[0105] The controller **62** and the motor driver **63** correspond to one example of a controller.

2. Second Embodiment

[0106] As the second embodiment, a second electric working machine **21** configured by replacing some components of the electric working machine **1** in the aforementioned embodiment (hereinafter, first embodiment) will be described.

[0107] As shown in FIG. 4, the second electric working machine **21** includes a second control power source **91**, a brushless motor **97**, and a motor driver **99** in place of the control power source **64**, the motor **61**, the motor driver **63** of the electric working machine **1**.

2-1. Second Control Power Source

[0108] The second control power source **91** includes a third converter **93** and a fourth converter **95** in place of the first converter **65** of the control power source **64**.

[0109] The third converter **93** includes a DC-DC converter that converts direct voltage and outputs a converted voltage. The third converter **93** converts the battery voltage V_B inputted to the input device **93a** to a second constant voltage V_{dd} , and outputs the second constant voltage V_{dd} through the outputter **93b**. The third converter **93** outputs **15** [V] as the second constant voltage V_{dd} . The third converter **93** has a maximum output current of 150 mA for voltage conversion.

[0110] The fourth converter **95** includes a series regulator that converts direct voltage and outputs a converted voltage. The fourth converter **95** converts the second constant voltage V_{dd} inputted to the input device **95a** to the constant voltage V_{cc} , and outputs the constant voltage V_{cc} through the outputter **95b**. The fourth converter **95** outputs **5** [V] as the constant voltage V_{cc} . The fourth converter **95** has a maximum output current of 100 mA for voltage conversion.

[0111] In other words, the second control power source **91** can convert the battery voltage V_B to the constant voltage V_{cc} using the third converter **93** and the fourth converter **95**. The constant voltage V_{cc} is supplied to each component (such as the controller **62**) of the second electric working machine **21** via the constant voltage supply line **81**. Power consumption required for voltage conversion in the third converter **93** and the fourth converter **95** corresponds to consumption current in mA order.

[0112] The second control power source **91** configured as above, when receiving the conduction command signal $Sc1$ indicating the control operation state from the operation state determiner, outputs the constant voltage V_{cc} using the third converter **93** and the fourth converter **95**, and outputs the constant voltage V_{cc} using the second converter **71**, thereby transitioning to a state to supply control power to the controller **62** (hereinafter, first conversion state).

[0113] Also, the second control power source **91**, when receiving the conduction command signal $Sc1$ indicating the low power operation state from the operation state determiner **75**, stops voltage conversion by the third converter **93** and the fourth converter **95**, and outputs the constant voltage V_{cc} using the second converter **71**, thereby transitioning to

a state to supply control power to the controller **62** (hereinafter, second conversion state).

[0114] The brushless motor **97** includes a 3-phase brushless motor. The motor driver **99** converts a direct current from the battery pack **100** to 3-phase AC current (U-PHASE drive current, V-PHASE drive current, and W-PHASE drive current) for driving the brushless motor **97** and outputs the current to the brushless motor **97**. The motor driver **99** drives the brushless motor **97** in accordance with the motor drive command Smd inputted from the controller **62**.

2-2. Change in Consumption Current Due to Switching of Operation State in Controller

[0115] Change in the consumption current I_a in the second control power source **91** due to switching of the operation state of the controller **62** will be described with reference to FIG. 5.

[0116] FIG. 5 shows switching of the operation state of the controller **62** and change in the consumption current I_a due to elapse of time with time t_0 as time when the user has ended the pulling operation of the trigger manipulator **9**.

[0117] During a period from time t_0 to time t_{11} when the sleep determination time T_s has elapsed, when a state continues in which the user does not perform the pulling operation of the trigger manipulator **9**, the controller **62** starts a process to transition the operation state (operation state switching process) from the control operation state to the low power operation state.

[0118] The controller **62**, when starting the operation state switching process, first executes a process to sequentially stop power supply to various devices and various circuits provided in the second electric working machine **21**. Along with this, the consumption current I_a gradually decreases from a tenth consumption current I_{a10} (time t_{11} to t_{12}), and electric current equivalent to current consumption (first current variation ΔI_{a11}) in various devices before stopping is reduced. The consumption current I_a at this time decreases to an eleventh consumption current I_{a11} .

[0119] The controller **62** then executes a process to output the state notification signal Smo indicating the low power operation state, as one step of the operation state switching process (time t_{12}). As a result, voltage conversion by the third converter **93** and the fourth converter **95** is stopped, and electric current equivalent to current consumption (second current variation ΔI_{a12}) required for voltage conversion in the third converter **93** and the fourth converter **95** is reduced. The consumption current I_a at this time decreases to a twelfth consumption current I_{a12} .

[0120] The controller **62** executes a process to transition the controller **62** itself to the low power operation state (sleep mode), as one step of the operation state switching process (time t_{13}). As a result, electric current equivalent to current consumption (third current variation ΔI_{a13}) corresponding to a difference between current consumption in the control operation state and current consumption in the low power operation state of the controller **62** is reduced. The consumption current I_a at this time decreases to a thirteenth consumption current I_{a13} .

[0121] By executing these steps, the controller **62** completes the operation state switching process and maintains the low power operation state until the user performs the pulling operation of the trigger manipulator **9**.

[0122] Thereafter, when the user performs the pulling operation of the trigger manipulator 9 (time t14), the controller 62 receives the trigger signal Str. As a result, the controller 62 itself transitions to the control operation state (wakes up) from the low power operation state (sleep mode). The controller 62 that has waken up starts the operation state switching process to transition the operation state from the low power operation state to the control operation state. Also, the trigger signal Str from the trigger manipulator 9 is inputted also to the operation state determiner 75, and the conduction command signal Sc1 from the operation state determiner 75 is inputted to the second control power source 91. As a result, voltage conversion by the third converter 93 and the fourth converter 95 is started. Accordingly, along with wake-up of the controller 62 and the voltage conversion operation of the third converter 93 and the fourth converter 95, the consumption current Ia gradually increases to the eleventh consumption current Ia11 (time t14 to t15).

[0123] The controller 62 then executes a process to output the state notification signal Smo (first state notification signal Smo1) indicating the control operation state, as one step of the operation state switching process (time t15). As a result, the constant voltage Vcc outputted from the outputter 95b of the fourth converter 95 is supplied to the constant voltage supply line 81 without voltage drop.

[0124] The controller 62 then executes a process to sequentially start power supply to various devices and various circuits provided in the second electric working machine 21, as one step of the operation state switching process (time t16). Along with this, the consumption current Ia increases to the tenth consumption current Ia10.

[0125] As above, the second electric working machine 21 stops voltage conversion in the third converter 93 and the fourth converter 95 in case that the operation state of the controller 62 is transitioned to the low power operation state. Thus, the consumption current Ia equivalent to the second current variation $\Delta Ia12$ can be reduced.

2-3. Effect

[0126] As described above, in the second electric working machine 21 of the second embodiment, in case that the controller 62 is in the low power operation state, the second control power source 91 transitions to the second conversion state, and the third converter 93 and the fourth converter 95 are not used for voltage conversion in the second control power source 91. Thus, the power consumption in the third converter 93 and the fourth converter 95 can be suppressed. As a result, in case that the operation state of the controller 62 is transitioned from the control operation state to the low power operation state when the second electric working machine 21 is not used, not only power consumption in the controller 62 but also power consumption in the third converter 93 and the fourth converter 95 can be reduced. Thus, power consumption when the second electric working machine 21 is not used can be reduced.

2-4. Correspondence Relationship Between Terms

[0127] The controller 62 and the motor driver 99 correspond to one example of the controller, the brushless motor 97 corresponds to one example of the driving device, and the third converter 93 and the fourth converter 95 correspond to one example of the first converter.

3. Third Embodiment

[0128] As the third embodiment, a third electric working machine 23 configured by replacing some components of the second electric working machine 21 in the second embodiment will be described.

[0129] As shown in FIG. 6, the third electric working machine 23 includes a third control power source 111 in place of the second control power source 91 of the second electric working machine 21.

3-1. Third Control Power Source

[0130] The third control power source 111 converts the battery voltage VB to the constant voltage Vcc, and outputs the constant voltage Vcc to the constant voltage supply line 81. The constant voltage Vcc is supplied to each part (such as the controller 62) of the third electric working machine 23 via the constant voltage supply line 81. In the third embodiment, the constant voltage Vcc is 5 [V]. Electric power supplied via the constant voltage supply line 81 is used, for example, as operating power of the controller 62, etc.

[0131] The third control power source 111 includes the third converter 93, the first switcher 67, a reverse flow suppressor 113, the fourth converter 95, a bypass current determiner 115, a third current path LC3, a bypass current path LC4, and a common current path LC5.

[0132] The third converter 93, the first switcher 67, the fourth converter 95 in the third embodiment have the same configuration as those in the second embodiment.

[0133] The third current path LC3 is a part of the current path from the battery pack 100 to the controller 62, and is provided with the third converter 93. The bypass current path LC4 is coupled in parallel to the third current path LC3. The common current path LC5 is directly coupled to the third current path LC3 and the bypass current path LC4, and is provided with the fourth converter 95.

[0134] A first end of the third current path LC3 and a first end of the bypass current path LC4 are coupled to a fourth junction P4 and the voltage conversion path LC. A second end of the third current path LC3 and a second end of the bypass current path LC4 are coupled to a fifth junction P5 and are coupled to a first end of the common current path LC5. A second end of the common current path LC5 is coupled to the constant voltage supply line 81.

[0135] The reverse flow suppressor 113 is provided in the third current path LC3 between the third converter 93 and the fifth junction P5. The reverse flow suppressor 113 is provided with a diode coupled in series to the third current path LC3. This diode is arranged to allow electric conduction from the third converter 93 to the fifth junction P5 and suppress electric conduction from the fifth junction P5 to the third converter 93. Thus, the reverse flow suppressor 113 allows output of the constant voltage Vcc from the outputter 93b of the third converter 93 to the fifth junction P5 and suppresses inflow of reverse current from the fifth junction P5 to the outputter 93b of the third converter 93.

[0136] The bypass current determiner 115 is provided in the bypass current path LC4. The bypass current determiner 115 includes a detection resistor 117 and a current determiner 119. The detection resistor 117 includes a resistive element coupled in series to the bypass current path LC4 and can output detection voltage corresponding to bypass current Ibp flowing through the bypass current path LC4. The current determiner 119 includes a FET, and is configured to

output current notification signal S_{ia} corresponding to the bypass current I_{bp} to the operation state determiner 75 based on voltage between both ends of the detection resistor 117.

[0137] In case that the first switcher 67 is OFF, and the operation state of the controller 62 is in the control operation state, power consumption in the controller 62 and the like via the constant voltage supply line 81 increases and the bypass current I_{bp} increases. Thus, potential of the input device 95a of the fourth converter 95 decreases. Also, in case that the first switcher 67 is OFF and the operation state of the controller 62 is in the low power operation state, power consumption in the controller 62 and the like via the constant voltage supply line 81 decreases and the bypass current I_{bp} decreases. Thus, potential of the input device 95a of the fourth converter 95 increases.

[0138] The current determiner 119 is configured to output the current notification signal S_{ia} corresponding to the bypass current I_{bp} . In case that the bypass current I_{bp} is larger than a predefined operation reference value I_{th} (for example, 5 [mA]), the FET is turned on, and the current determiner 119 outputs the current notification signal S_{ia} having the same potential as that of the battery voltage VB (hereinafter, first current notification signal S_{ia1}). In case that the bypass current I_{bp} is equal to or smaller than the operation reference value I_{th} , the FET is turned off, and the current determiner 119 outputs the current notification signal S_{ia} having potential lower than that of the battery voltage VB (hereinafter, second current notification signal S_{ia2}).

[0139] In other words, the bypass current determiner 115 is configured to determine whether the operation state of the controller 62 is the control operation state or the low power operation state based on a result of comparison between the bypass current I_{bp} and the operation reference value I_{th} .

[0140] The current determiner 119, when determining that the operation state of the controller 62 is the control operation state, outputs the first current notification signal S_{ia1} to the operation state determiner 75. As a result, the conduction command signal S_{c1} indicating the control operation state is outputted from the operation state determiner 75 to the first switcher 67, and voltage conversion by the third converter 93 is executed. At this time, the third control power source 111 outputs the constant voltage V_{cc} using the third converter 93 and the fourth converter 95, thereby transitioning a state to supply control power to the controller 62 (hereinafter, first conversion state).

[0141] The current determiner 119, when determining that the operation state of the controller 62 is the low power operation state, outputs the second current notification signal S_{ia2} to the operation state determiner 75. As a result, the conduction command signal S_{c1} indicating the low power operation state is outputted from the operation state determiner 75 to the first switcher 67, and voltage conversion by the third converter 93 is stopped. At this time, the third control power source 111 outputs the constant voltage V_{cc} using the fourth converter 95, thereby transitioning to a state to supply control power to the controller 62 (hereinafter, second conversion state)

3-2. Change in Consumption Current Due to Switching of Operation State in Controller

[0142] Change in the consumption current I_a in the third control power source 111 due to switching of the operation state of the controller 62 will be described with reference to FIG. 7.

[0143] FIG. 7 shows switching of the operation state of the controller 62 and change in consumption current due to elapse of time with time t_0 as time when the user has ended the pulling operation of the trigger manipulator 9.

[0144] During a period from time t_0 to time t_{21} when the sleep determination time T_s has elapsed, when a state continues in which the user does not perform the pulling operation of the trigger manipulator 9, the controller 62 starts a process to transition the operation state (operation state switching process) from the control operation state to the low power operation state.

[0145] The controller 62, when starting the operation state switching process, first executes a process to sequentially stop power supply to various devices and various circuits provided in the third electric working machine 23. Along with this, the consumption current I_a gradually decreases from a twentieth consumption current I_{a20} (time t_{21} to t_{22}), and electric current equivalent to the current consumption (first current variation ΔI_{a21}) in various devices before stopping is reduced. The consumption current I_a at this time decreases to a twenty-first consumption current I_{a21} .

[0146] The controller 62 then executes a process to transition the controller 62 itself to the low power operation state (sleep mode), as one step of the operation state switching process (time t_{22}). As a result, electric current equivalent to current consumption (second current variation ΔI_{a22}) corresponding to a difference between current consumption in the control operation state and current consumption in the low power operation state of the controller 62 is reduced, and the consumption current I_a at this time decreases to a twenty-second consumption current I_{a22} . The second current variation ΔI_{a22} corresponds to the third current variation ΔI_{a3} of the first embodiment and the third current variation ΔI_{a13} of the second embodiment.

[0147] Thereafter, when the bypass current determiner 115 determines that the operation state of the controller 62 is the low power operation state due to decrease in current consumption of the controller 62, the conduction command signal S_{c1} indicating the low power operation state is outputted from the operation state determiner 75 to the first switcher 67, and voltage conversion by the third converter 93 is stopped. As a result, electric current equivalent to current consumption (third current variation ΔI_{a23}) required for voltage conversion in the third converter 93 is reduced, and the consumption current I_a at this time decreases to a twenty-third consumption current I_{a23} . The third current variation ΔI_{a23} corresponds to the second current variation ΔI_{a2} of the first embodiment and the second current variation ΔI_{a12} of the second embodiment.

[0148] By executing these steps, the controller 62 completes the operation state switching process, and maintains the low power operation state until the user performs the pulling operation of the trigger manipulator 9.

[0149] Thereafter, when the user performs the pulling operation of the trigger manipulator 9 (time t_{24}), the trigger signal S_{tr} is inputted to the controller 62. As a result, the controller 62 itself transitions to the control operation state (wakes up) from the low power operation state (sleep mode). The controller 62 that has woken up starts the operation state switching process to transition the operation state from the low power operation state to the control operation state. Also, when the trigger signal S_{tr} from the trigger manipulator 9 is inputted also to the operation state determiner 75, and the conduction command signal S_{c1} from the operation

state determiner 75 is inputted to the third control power source 111, voltage conversion by the third converter 93 is started. Accordingly, along with wake-up of the controller 62 and the voltage conversion operation by the third converter 93, the consumption current Ia gradually increases to the twenty-first consumption current Ia21 (time t24 to t25). The consumption current Ia is increased by the second current variation $\Delta Ia22$ from the twenty-third consumption current Ia23 by wake-up of the controller 62 and becomes a twenty-fourth consumption current Ia24 (time t24). Thereafter, the consumption current Ia is increased by the third current variation $\Delta Ia23$ by the voltage conversion operation of the third converter 93 and becomes the twenty-first consumption current Ia21 (time t25).

[0150] At this time, when the bypass current determiner 115 determines that the operation state of the controller 62 is the control operation state due to increase in current consumption in the controller 62, the conduction command signal Sc1 indicating the control operation state is outputted from the operation state determiner 75 to the first switcher 67. At this time, voltage conversion by the third converter 93 is already executed based on the trigger signal Str from the trigger manipulator 9. However, even if manipulation of the trigger manipulator 9 by the user is ended, the control operation state of the controller 62 is maintained and voltage conversion by the third converter 93 continues until the sleep determination time Ts elapses.

[0151] The controller 62 then executes a process to sequentially start power supply to various devices and various circuits provided in the third electric working machine 23, as one step in the operation state switching process (time t26). Along with this, the consumption current Ia increases to a twentieth consumption current Ia20.

[0152] As above, the third electric working machine 23, when the operation state of the controller 62 is transitioned to the low power operation state, stops voltage conversion in the third converter 93 based on the determination result by the bypass current determiner 115, thereby reducing the consumption current Ia equivalent to the third current variation $\Delta Ia23$.

3-3. Effect

[0153] As described above, in the third electric working machine 23 of the third embodiment, in case that the controller 62 is in the low power operation state, the third control power source 111 transitions to the second conversion state based on the determination result by the bypass current determiner 115, and the third converter 93 is not used for voltage conversion in the third control power source 111. Thus, power consumption in the third converter 93 can be suppressed. As a result, in case that the operation state of the controller 62 is transitioned from the control operation state to the low power operation state when the third electric working machine 23 is not used, not only power consumption in the controller 62 but also power consumption in the third converter 93 can be reduced. Thus, power consumption when the third electric working machine 23 is not used can be reduced.

3-4. Correspondence Between Terms

[0154] The controller 62 and the motor driver 99 correspond to one example of the controller, the brushless motor 97 corresponds to one example of the driving device, the

third converter 93 corresponds to one example of the first converter, and the fourth converter 95 corresponds to one example of the second converter.

[0155] The operation state determiner 75 and the bypass current determiner 115 corresponds to one example of the operation state determiner, and the second constant voltage Vdd corresponds to one example of a first control voltage.

4. Fourth Embodiment

[0156] As the fourth embodiment, a fourth electric working machine 25 configured by replacing some components of the third electric working machine 23 in the third embodiment will be described.

[0157] As shown in FIG. 8, the fourth electric working machine 25 includes a fourth control power source 121 and a second bypass current determiner 131 in place of the third control power source 111 and the bypass current determiner 115 of the third electric working machine 23, respectively.

4-1. Fourth Control Power Source

[0158] The fourth control power source 121 converts the battery voltage VB to the constant voltage Vcc, and outputs the constant voltage Vcc to the constant voltage supply line 81. The constant voltage Vcc is supplied to each part (such as the controller 62) of the fourth electric working machine 25 via the constant voltage supply line 81. In the fourth embodiment, the constant voltage Vcc is 5 [V]. Electric power supplied from the fourth control power source 121 via the constant voltage supply line 81 is used, for example, as operating power of the controller 62, etc.

[0159] The fourth control power source 121 includes the third converter 93, the first switcher 67, the reverse flow suppressor 113, the fourth converter 95, a limiting resistor 123, the third current path LC3, the bypass current path LC4, and the common current path LC5.

[0160] The third converter 93, the first switcher 67, the fourth converter 95, the third current path LC3, the bypass current path LC4, and the common current path LC5 in the fourth embodiment have the same configuration as those of the third embodiment.

[0161] The limiting resistor 123 is coupled in series to the bypass current path LC4. The limiting resistor 123 includes a resistive element, and keeps the bypass current Ibp flowing through the bypass current path LC4 from becoming excessive.

[0162] The second bypass current determiner 131 includes a hysteresis comparator 133, a resistor 135, a resistor 134, and a reference voltage 136. The second bypass current determiner 131 is electrically coupled to the fifth junction P5 via the sixth path LC6, and is configured to detect potential of the input device 95a of the fourth converter 95 and detect the bypass current Ibp. The second bypass current determiner 131 is configured to output the current notification signal Sia corresponding to the bypass current Ibp to the operation state determiner 75.

[0163] As described in the third embodiment, in case that the first switcher 67 is OFF, and the operation state of the controller 62 is the control operation state, power consumption in the controller 62, etc. via the constant voltage supply line 81 increases, and the bypass current Ibp increases. Thus, potential of the input device 95a of the fourth converter 95 decreases. Also, in case that the first switcher 67 is OFF, and the operation state of the controller 62 is the low power

operation state, power consumption in the controller 62, etc. via the constant voltage supply line 81 decreases, and the bypass current I_{bp} decreases. Thus, potential of the input device 95a of the fourth converter 95 increases.

[0164] The second bypass current determiner 131, outputs the current notification signal S_{ia} having the same potential as the battery voltage V_B (hereinafter, first current notification signal S_{ia1}), when a specific condition is satisfied. The specific condition herein is that the bypass current I_{bp} is larger than a predefined operation reference value I_{th} (for example, 5 [mA]), and potential of the fifth junction P5 (inputter 95a of the fourth converter 95) is lower than a determination voltage V_{th} . The second bypass current determiner 131, when the bypass current I_{bp} is equal to or lower than the operation reference value I_{th} , and potential of the fifth junction P5 (input device 95a of the fourth converter 9) exceeds the determination voltage V_{th} , outputs the current notification signal S_{ia} having lower potential than the battery voltage V_B (hereinafter, second current notification signal S_{ia2}).

[0165] In other words, the second bypass current determiner 131 is configured to determine whether the operation state of the controller 62 is the control operation state or the low power operation state based on the result of comparison between the bypass current I_{bp} and the operation reference value I_{th} .

[0166] The second bypass current determiner 131 includes the hysteresis comparator 133, and can set the determination voltage V_{th} used for output determination of the first current notification signal S_{ia1} (hereinafter, first determination voltage V_{th1}) and the determination voltage V_{th} used for output determination of the second current notification signal S_{ia2} (hereinafter, second determination voltage V_{th2}) to different values.

[0167] For example, in case that output voltage of the reference voltage 136 is set to be the determination voltage V_{th} ($=V_{dd}+\Delta V_a=17$ [V]) obtained by adding a specified adjustment voltage ΔV_a ($=2$ [V]) to the second constant voltage V_{dd} , and a hysteresis width by the the hysteresis comparator 133 is set to 1 [V], the first determination voltage V_{th1} is 16 [V] and the second determination voltage V_{th2} is 18 [V].

[0168] In this case, when potential of the fifth junction P5 (input device 95a of the fourth converter 95) falls below 16 [V], the second bypass current determiner 131 determines that the operation state of the controller 62 is the control operation state, and starts output of the first current notification signal S_{ia1} . Thereafter, while potential of the fifth junction P5 is equal to or below 18 [V], the second bypass current determiner 131 determines that the operation state of the controller 62 is the control operation state, and continues output of the first current notification signal S_{ia1} . Thereafter, when potential of the fifth junction P5 exceeds 18 [V], the second bypass current determiner 131 determines that the operation state of the controller 62 is the low power operation state, and starts output of the second current notification signal S_{ia2} . Thereafter, while potential of the fifth junction P5 is equal to or above 16 [V], the second bypass current determiner 131 determines that the operation state of the controller 62 is the low power operation state, and continues output of the second current notification signal S_{ia2} . Thereafter, when potential of the fifth junction P5 falls below 16 [V], the second bypass current determiner 131 starts output of the first current notification signal S_{ia1} .

[0169] The second bypass current determiner 131 outputs the first current notification signal S_{ia1} to the operation state determiner 75 when determining that the operation state of the controller 62 is the control operation state. As a result, the conduction command signal S_{c1} indicating the control operation state is outputted from the operation state determiner 75 to the first switcher 67, and voltage conversion by the the third converter 93 is executed. At this time, the fourth control power source 121 outputs the constant voltage V_{cc} using the third converter 93 and the fourth converter 95, thereby transitioning to a state to supply control power to the controller 62 (hereinafter, first conversion state).

[0170] The second bypass current determiner 131 outputs the second current notification signal S_{ia2} to the operation state determiner 75 when determining that the operation state of the controller 62 is the low power operation state. As a result, the conduction command signal S_{c1} indicating the low power operation state is outputted from the operation state determiner 75 to the first switcher 67, and voltage conversion by the third converter 93 is stopped. At this time, the fourth control power source 121 outputs the constant voltage V_{cc} using the fourth converter 95, thereby transitioning to a state to supply control power to the controller 62 (hereinafter, second conversion state).

4-2. Change in Consumption Current Due to Switching of Operation State in Controller

[0171] Change in the consumption current I_a in the fourth control power source 121 due to switching of the operation state of the controller 62 will be described with reference to FIG. 9.

[0172] FIG. 9 shows switching of the operation state of the controller 62 and change in consumption current due to elapse of time with time t_0 as time when the user has ended the pulling operation of the trigger manipulator 9.

[0173] During a period from time t_0 to time t_{31} when the sleep determination time T_s has elapsed, when a state continues in which the user does not perform the pulling operation of the trigger manipulator 9, the controller 62 starts a process to transition the operation state (operation state switching process) from the control operation state to the low power operation state.

[0174] The controller 62, when starting the operation state switching process, first executes a process to sequentially stop power supply to various devices and various circuits provided in the fourth electric working machine 25. Along with this, the consumption current I_a gradually decreases from a thirtieth consumption current I_{a30} (time t_{31} to t_{32}), and electric current equivalent to the current consumption (first current variation ΔI_{a31}) in various devices before stopping is reduced. The consumption current I_a at this time decreases to a thirty-first consumption current I_{a31} .

[0175] The controller 62 then executes a process to transition the controller 62 itself to the low power operation state (sleep mode), as one step of the operation state switching process (time t_{32}). As a result, electric current equivalent to current consumption (second current variation ΔI_{a32}) corresponding to a difference between current consumption in the control operation state and current consumption in the low power operation state of the controller 62 is reduced, and the consumption current I_a at this time decreases to a thirty-second consumption current I_{a32} .

[0176] Thereafter, when the second bypass current determiner 131 determines that the operation state of the con-

troller 62 is the low power operation state due to decrease in current consumption of the controller 62, the conduction command signal Sc1 indicating the low power operation state is outputted from the operation state determiner 75 to the first switcher 67, and voltage conversion by the third converter 93 is stopped. As a result, electric current equivalent to current consumption (third current variation $\Delta Ia33$) required for voltage conversion in the third converter 93 is reduced, and the consumption current Ia at this time decreases to a thirty-third consumption current Ia33.

[0177] By executing these steps, the controller 62 completes the operation state switching process, and maintains the low power operation state until the user performs the pulling operation of the trigger manipulator 9.

[0178] Thereafter, when the user performs the pulling operation of the trigger manipulator 9 (time t34), the trigger signal Str is inputted to the controller 62. As a result, the controller 62 itself transitions to the control operation state (wakes up) from the low power operation state (sleep mode). The controller 62 that has waken up starts the operation state switching process to transition the operation state from the low power operation state to the control operation state. Also, when the trigger signal Str from the trigger manipulator 9 is inputted also to the operation state determiner 75, and the conduction command signal Sc1 from the operation state determiner 75 is inputted to the fourth control power source 121, voltage conversion by the third converter 93 is started. Accordingly, along with wake-up of the controller 62 and the voltage conversion operation by the third converter 93, the consumption current Ia gradually increases to the thirty-first consumption current Ia31 (time t34 to t35). The consumption current Ia is increased by the second current variation $\Delta Ia32$ from the thirty-third consumption current Ia33 by wake-up of the controller 62 and becomes a thirty-fourth consumption current Ia34 (time t34). Thereafter, the consumption current Ia is increased by the third current variation $\Delta Ia33$ by the voltage conversion operation of the third converter 93 and becomes the thirty-first consumption current Ia31 (time t35).

[0179] At this time, when the second bypass current determiner 131 determines that the operation state of the controller 62 is the control operation state due to increase in current consumption in the controller 62, the conduction command signal Sc1 indicating the control operation state is outputted from the operation state determiner 75 to the first switcher 67. At this time, voltage conversion by the third converter 93 is already executed based on the trigger signal Str from the trigger manipulator 9. However, even if manipulation of the trigger manipulator 9 by the user is ended, the control operation state of the controller 62 is maintained and voltage conversion by the third converter 93 continues until the sleep determination time Ts elapses.

[0180] The controller 62 then executes a process to sequentially start power supply to various devices and various circuits provided in the fourth electric working machine 25, as one step in the operation state switching process (time t36). Along with this, the consumption current Ia increases to a thirtieth consumption current Ia30.

[0181] As above, the fourth electric working machine 25, when the operation state of the controller 62 is transitioned to the low power operation state, stops voltage conversion in the third converter 93 based on the determination result by

the second bypass current determiner 131, thereby reducing the consumption current Ia equivalent to the third current variation $\Delta Ia33$.

4-3. Effect

[0182] As described above, in the fourth electric working machine 25 of the fourth embodiment, in case that the controller 62 is in the low power operation state, the fourth control power source 121, based on determination result in the second bypass current determiner 131, transitions to the second conversion state, and the third converter 93 is not used for voltage conversion in the fourth control power source 121. Thus, power consumption in the third converter 93 can be suppressed. As a result, in case that the operation state of the controller 62 is transitioned from the control operation state to the low power operation state when the fourth electric working machine 25 is not used, not only power consumption in the controller 62 but also power consumption in the third converter 93 can be reduced. Thus, power consumption when the fourth electric working machine 25 is not used can be reduced.

4-4. Correspondence Between Terms

[0183] The fourth electric working machine 25 corresponds to one example of the electric working machine, and the operation state determiner 75 and the second bypass current determiner 131 correspond to one example of the operation state determiner.

5. Fifth Embodiment

[0184] As the fifth embodiment, a fifth electric working machine 27 configured by replacing some components of the second electric working machine 21 in the second embodiment will be described.

[0185] As shown in FIG. 10, the fifth electric working machine 27 includes a fifth control power source 141 and a multiple-output power source 102 in place of the second control power source 91 and the battery pack 100 of the second electric working machine 21, respectively.

[0186] The multiple-output power source 102 includes battery packs (first battery pack 103 and second battery pack 104), voltage outputters (first voltage outputter 102a and second voltage outputter 102b), and a reference voltage 102c.

[0187] The first battery pack 103 and the second battery pack 104 are coupled in series. Each of the first battery pack 103 and the second battery pack 104 includes a rechargeable battery (not shown) that can be repeatedly charged and discharged. The first battery pack 103 has an output voltage of 36 [V]. The second battery pack 104 has an output voltage of 36 [V].

[0188] The first voltage outputter 102a is coupled to a positive electrode of the second battery pack 104. The second voltage outputter 102b is coupled to a positive electrode of the first battery pack 103 and a negative electrode of the second battery pack 104. The reference voltage 102c is coupled to a negative electrode of the first battery pack 103.

[0189] The multiple-output power source 102 is configured such that each of the voltage outputters (first voltage outputter 102a and second voltage outputter 102b) outputs a different voltage based on the reference voltage 102c. The multiple-output power source 102 outputs a first battery

voltage VB1 (VB1=72 [V]) from the first voltage outputter **102a**, and outputs a second battery voltage VB2 (VB2=36 [V]) from the second voltage outputter **102b**.

[0190] The first battery pack **103** outputs a first interruption command signal Sb1 in case of a faulty state such as dropped output voltage. The second battery pack **104** outputs a second interruption command signal Sb2 in case of a faulty state such as dropped output voltage.

5-1. Fifth Control Power Source

[0191] The fifth control power source **141** converts the first battery voltage VB1 or the second battery voltage VB2 to the constant voltage Vcc, and outputs the constant voltage Vcc (Vcc=5 [V]) to the constant voltage supply line **81**.

[0192] The fifth control power source **141** is configured by the second control power source **91** to which the second switcher **143** and the third switcher **145** are added, and in which a coupling destination of the second current path LC2 is changed. The following description mainly describes a difference between the second control power source **91** and the fifth control power source **141**.

[0193] A first end of the second current path LC2 is coupled to the second voltage outputter **102b** of the multiple-output power source **102**. A second end of the second current path LC2 is coupled to the third junction P3 and the constant voltage supply line **81**.

[0194] The second switcher **143** and the third switcher **145** are provided in the second current path LC2 between the input device **71a** of the second converter **71** and the second voltage outputter **102b** of the multiple-output power source **102**. Each of the second switcher **143** and the third switcher **145** is provided with a switcher (such as a FET) coupled in series to the second current path LC2.

[0195] The second switcher **143** is configured to switch the switcher to a conduction state (ON state) or a non-conduction state (OFF state) based on the first interruption command signal Sb1 from the first battery pack **103**. The third switcher **145** is configured to switch the switcher to a conduction state (ON state) or a non-conduction state (OFF state) based on the second interruption command signal Sb2 from the second battery pack **104**.

[0196] The second switcher **143** and the third switcher **145** are configured to switch electric conduction in the second current path LC2 from the second voltage outputter **102b** to the second converter **71** to a conduction state or a non-conduction state. This allows the second switcher **143** and the third switcher **145** to switch an input state of the second battery voltage VB2 to the second converter **71** based on the first interruption command signal Sb1 and the second interruption command signal Sb2.

[0197] The third converter **93** is provided with a DC-DC converter that converts direct voltage and outputs a converted voltage. The third converter **93** converts the first battery voltage VB1 (VB1=72 [V]) inputted to the input device **93a** to the second constant voltage Vdd, and outputs the second constant voltage Vdd through the outputter **93b**. The third converter **93** outputs 15 [V] as the second constant voltage Vdd. The third converter **93** has a maximum output current of 150 mA for voltage conversion.

[0198] The fifth control power source **141** configured as above, when receiving the conduction command signal Sc1 indicating the control operation state from the operation state determiner **75**, outputs the constant voltage Vcc using the third converter **93** and the fourth converter **95**, and

outputs the constant voltage Vcc using the second converter **71**, thereby transitioning to a state to supply control power to the controller **62** (hereinafter, first conversion state).

[0199] Also, the fifth control power source **141**, when receiving the conduction command signal Sc1 indicating the low power operation state from the operation state determiner **75**, stops voltage conversion by the third converter **93** and the fourth converter **95**, and outputs the constant voltage Vcc using the second converter **71**, thereby transitioning to a state to supply control power to the controller **62** (hereinafter, second conversion state).

[0200] Further, the fifth control power source **141** sets the second switcher **143** or the third switcher **145** to a non-conduction state based on the first interruption command signal Sb1 from the first battery pack **103** or the second interruption command signal Sb2 from the second battery pack **104**, thereby stopping input of the second battery voltage VB2 to the second converter **71**. In other words, when at least one of the first battery pack **103** and the second battery pack **104** is in a faulty state, the fifth control power source **141** is configured to stop input of the second battery voltage VB2 to the second converter **71**, thereby stopping output of the constant voltage Vcc by the second converter **71**.

[0201] Also, the fifth control power source **141** may include a power holding circuit **147**. The power holding circuit **147** is coupled to the first current path LC1 between the third converter **93** and the fourth converter **95**. The power holding circuit **147** includes a resistor **147a**, a diode **147b**, and a capacitor **147c**.

[0202] The power holding circuit **147** is configured to charge the capacitor **147c** via the resistor **147a**, and discharge the capacitor **147c** via the diode **147b**. This allows the power holding circuit **147** to quickly discharge the capacitor **147c** while suppressing the second constant voltage Vdd due to inrush-current at the start of charging the capacitor **147c**.

[0203] With the power holding circuit **147**, the second constant voltage Vdd and the constant voltage Vcc can be maintained by an electrical charge charged to the capacitor **147c** of the power holding circuit **147** during a certain period after the third converter **93** stops output of the second constant voltage Vdd, and the controller **62** can be driven. Therefore, even if the multiple-output power source **102** is suddenly removed or output (power source) from the multiple-output power source **102** is lost due to some failure, the second constant voltage Vdd and the constant voltage Vcc are maintained by discharge of the capacitor **147c**. Therefore, the controller **62** can appropriately practice a shutdown process. The shutdown process includes, for example, a process of writing various history information and various setting states to a non-volatile memory.

5-2. Effect

[0204] As described above, in the fifth electric working machine **27** of the fifth embodiment, in case that the controller **62** is in the low power operation state, the fifth control power source **141** transitions to the second conversion state, and the third converter **93** and the fourth converter **95** are not used for voltage conversion in the fifth control power source **141**. Thus, power consumption in the third converter **93** and the fourth converter **95** can be suppressed. As a result, in case that the operation state of the controller **62** is transitioned from the control operation state to the low power operation state when the fifth electric working machine **27** is

not used, not only power consumption in the controller **62** but also power consumption in the third converter **93** and the fourth converter **95** can be reduced. Thus, power consumption when the fifth electric working machine **27** is not used can be reduced.

[0205] Also, the fifth electric working machine **27** uses the multiple-output power source **102** having multiple battery packs as the power source. Thus, as compared to a configuration using one battery pack, increased output operation based on increased voltage is possible. The multiple-output power source **102** can increase a maximum voltage that can be outputted in accordance with the number of battery packs by employing a configuration with multiple battery packs.

[0206] In the fifth electric working machine **27**, the second converter **71** is coupled not to the first voltage outputter **102a** having the largest output voltage but coupled to the second voltage outputter **102b** having the smallest output voltage. In other words, the second converter **71** is configured not to convert the first battery voltage $VB1$ ($VB1=72$ [V]) to the constant voltage Vcc ($Vcc=5$ [V]) but configured to convert the second battery voltage $VB2$ ($VB1=36$ [V]) to the constant voltage Vcc .

[0207] This allows the second converter **71** to reduce voltage change in voltage conversion in the second converter **71** as compared to a case of voltage conversion from the first battery voltage $VB1$ to the constant voltage Vcc . Therefore, the fifth electric working machine **27** can reduce power loss due to voltage conversion in the second converter **71** as compared to a case of large voltage change.

[0208] In the fifth electric working machine **27**, “the third converter **93** and the fourth converter **95**” (corresponding to one example of the first converter) are coupled to the first voltage outputter **102a** having a larger output voltage ($VB1=72$ [V]) than the second voltage outputter **102b** having the output voltage ($VB2=36$ [V]) to which the second converter **71** is coupled. As a result, electric energy that can be outputted from “the third converter **93** and the fourth converter **95**” is larger than electric energy that can be outputted from the second converter **71**. “The third converter **93** and the fourth converter **95**” can supply sufficient electric power to the controller **62** as compared to the second converter **71**.

5-3. Correspondence Between Terms

[0209] The multiple-output power source **102** corresponds to one example of the power source, and the third converter **93** and the fourth converter **95** correspond to one example of the first converter.

6. Sixth Embodiment

[0210] As the sixth embodiment, a sixth electric working machine **29** configured by replacing some components of the third electric working machine **23** in the third embodiment will be described.

[0211] As shown in FIG. **11**, the sixth electric working machine **29** includes a sixth control power source **151** and the multiple-output power source **102** in place of the third control power source **111** and the battery pack **100** of the third electric working machine **23**, respectively.

[0212] The multiple-output power source **102** in the sixth embodiment has the same configuration as that of the fifth embodiment, and thus will not be further described.

6-1. Sixth Control Power Source

[0213] The sixth control power source **151** converts the first battery voltage $VB1$ or the second battery voltage $VB2$ to the constant voltage Vcc , and outputs the constant voltage Vcc ($Vcc=5$ [V]) to the constant voltage supply line **81**.

[0214] The sixth control power source **151** is configured by the third control power source **111** to which a fourth switcher **153** and a fifth switcher **155** are added, and in which a coupling destination of the bypass current path **LC4** is changed. The following description mainly describes a difference between the third control power source **111** and the sixth control power source **151**.

[0215] The first end of the bypass current path **LC4** is coupled to the second voltage outputter **102b** of the multiple-output power source **102**. The second end of the bypass current path **LC4** is coupled to the fifth junction **P5** and the first end of the common current path **LC5**.

[0216] The fourth switcher **153** and the fifth switcher **155** are provided in the bypass current path **LC4** between the bypass current determiner **115** and the second voltage outputter **102b** of the multiple-output power source **102**. Each of the fourth switcher **153** and the fifth switcher **155** includes a switcher (such as a FET) coupled in series to the bypass current path **LC4**.

[0217] The fourth switcher **153** is configured to switch the switcher to a conduction state (ON state) or a non-conduction state (OFF state) based on the first interruption command signal $Sb1$ from the first battery pack **103**. The fifth switcher **155** is configured to switch the switcher to a conduction state (ON state) or a non-conduction state (OFF state) based on the second interruption command signal $Sb2$ from the second battery pack **104**.

[0218] The fourth switcher **153** and the fifth switcher **155** are configured to switch electric conduction in the bypass current path **LC4** from the second voltage outputter **102b** to the fourth converter **95** via the bypass current determiner **115** to a conduction state or a non-conduction state. This allows the fourth switcher **153** and the fifth switcher **155** to switch an input state of the second battery voltage $VB2$ to the fourth converter **95** via the bypass current determiner **115** based on the first interruption command signal $Sb1$ and the second interruption command signal $Sb2$.

[0219] The third converter **93** is provided with a DC-DC converter that converts direct voltage and outputs a converted voltage. The third converter **93** converts the first battery voltage $VB1$ ($VB1=72$ [V]) inputted to the input device **93a** to the second constant voltage Vdd , and outputs the second constant voltage Vdd through the outputter **93b**. The third converter **93** outputs 15 [V] as the second constant voltage Vdd . The third converter **93** has a maximum output current of 150 mA for voltage conversion.

[0220] In the sixth control power source **151** configured as above, when the first current notification signal $Sia1$ is outputted from the current determiner **119** to the operation state determiner **75**, the conduction command signal $Sc1$ indicating the control operation state is outputted from the operation state determiner **75** to the first switcher **67**, and voltage conversion by the third converter **93** is executed. At this time, the sixth control power source **151** converts the first battery voltage $VB1$ to the constant voltage Vcc using the third converter **93** and the fourth converter **95** and outputs the constant voltage Vcc , thereby transitioning to a state to supply control power to the controller **62** (hereinafter, first conversion state).

[0221] Also, in the sixth control power source 151, when the second current notification signal Sia_2 is outputted from the current determiner 119 to the operation state determiner 75, the conduction command signal Sc_1 indicating the low power operation state is outputted from the operation state determiner 75 to the first switcher 67, and voltage conversion by the third converter 93 is stopped. At this time, the sixth control power source 151 converts the second battery voltage VB_2 to the constant voltage V_{cc} using the fourth converter 95 and outputs the constant voltage V_{cc} , thereby transitioning to a state to supply control power to the controller 62 (hereinafter, second conversion state).

[0222] Further, the sixth control power source 151 sets the fourth switcher 153 or the fifth switcher 155 to a non-conduction state based on the first interruption command signal Sb_1 from the first battery pack 103 or the second interruption command signal Sb_2 from the second battery pack 104, thereby stopping input of the second battery voltage VB_2 to the fourth converter 95 via the bypass current path LC4. In other words, when at least one of the first battery pack 103 and the second battery pack 104 is in faulty state, the sixth control power source 151 is configured to stop input of the second battery voltage VB_2 to the fourth converter 95 via the bypass current path LC4, thereby stopping output of the constant voltage V_{cc} by the fourth converter 95 via the bypass current path LC4.

6-2. Effect

[0223] As described above, in the sixth electric working machine 29 of the sixth embodiment, in case that the controller 62 is in the low power operation state, the sixth control power source 151 transitions to the second conversion state, and the third converter 93 is not used for voltage conversion in the sixth control power source 151. Thus, power consumption in the third converter 93 can be suppressed. As a result, in case that the operation state of the controller 62 is transitioned from the control operation state to the low power operation state when the sixth electric working machine 29 is not used, not only power consumption in the controller 62 but also power consumption in the third converter 93 can be reduced. Thus, power consumption when the sixth electric working machine 29 is not used can be reduced.

[0224] Also, the sixth electric working machine 29 uses the multiple-output power source 102 having multiple battery packs as the power source. Thus, as compared to a configuration using one battery pack, increased output operation based on increased voltage is possible.

[0225] In the sixth electric working machine 29, the fourth converter 95 is coupled not to the first voltage outputter 102a having the largest output voltage but coupled to the second voltage outputter 102b having the smallest output voltage. In other words, the fourth converter 95 is configured not to convert the first battery voltage VB_1 ($VB_1=72$ [V]) to the constant voltage V_{cc} ($V_{cc}=5$ [V]) but configured to convert the second battery voltage VB_2 ($VB_2=36$ [V]) to the constant voltage V_{cc} .

[0226] This allows the fourth converter 95 to reduce voltage change in voltage conversion in the fourth converter 95 as compared to a case of voltage conversion from the first battery voltage VB_1 to the constant voltage V_{cc} . Therefore, the sixth electric working machine 29 can reduce power loss due to voltage conversion in the fourth converter 95 as compared to a case of large voltage change.

[0227] In the sixth electric working machine 29, “the third converter 93 and the fourth converter 95” (corresponding to one example of the first converter) are coupled to the first voltage outputter 102a having a larger output voltage ($VB_1=72$ [V]) than the second voltage outputter 102b having the output voltage ($VB_2=36$ [V]) to which the fourth converter 95 (corresponding to one example of the second converter) is coupled. As a result, electric energy that can be outputted from “the third converter 93 and the fourth converter 95” is larger than electric energy that can be outputted when the fourth converter 95 is used alone. “The third converter 93 and the fourth converter 95” can supply sufficient electric power to the controller 62 as compared to the case in which the fourth converter 95 is used alone.

6-3. Correspondence Between Terms

[0228] The multiple-output power source 102 corresponds to one example of the power source, “the third converter 93 and the fourth converter 95” correspond to one example of the first converter, and the fourth converter 95 alone corresponds to one example of the second converter.

7. Other Embodiments

[0229] The embodiments of present disclosure have been described in the above. The present disclosure is not limited to the aforementioned embodiments and can be practiced in various forms without departing from the gist of the present disclosure.

[0230] (a) In the aforementioned third embodiment and fourth embodiment, the state notification signal Smo outputted from the controller 62 is not used. However, as in the first embodiment and the second embodiment, the state notification signal Smo may be used. For example, in the third electric working machine 23 of the third embodiment, the state notification signal Smo (first state notification signal Smo_1 and second state notification signal Smo_2), in addition to the current notification signal Sia outputted from the bypass current determiner 115, may be inputted to the operation state determiner 75. In other words, the operation state determiner 75 may be configured to receive the first state notification signal Smo_1 and the second state notification signal Smo_2 .

[0231] This operation state determiner 75 determines that the operation state of the controller 62 is the control operation state when the bypass current I_{bp} is larger than the operation reference value I_{th} or when the first state notification signal Smo_1 is received. This operation state determiner 75 determines that the operation state of the controller 62 is the low power operation state when the bypass current I_{bp} is equal to or smaller than the operation reference value I_{th} and the second state notification signal Smo_2 is received.

[0232] In this electric working machine, the operation state determiner 75 can determine the operation state of the controller 62 based on the first state notification signal Smo_1 and the second state notification signal Smo_2 , in addition to the result of comparison between the bypass current I_{bp} and the operation reference value I_{th} .

[0233] In the fourth electric working machine 25 of the fourth embodiment as well, the state notification signal Smo (first state notification signal Smo_1 and second state notification signal Smo_2), in addition to the current notification

signal *Sia* outputted from the second bypass current determiner **131**, may be inputted to the operation state determiner **75**.

[0234] Also, the operation determination process executed in the operation state determiner **75** may be replaced with an operation determination process as an internal process of the controller **62**. For example, the controller **62** may generate the conduction command signal *Sc1* using the trigger signal *Str* and the state notification signal *Smo* and output the conduction command signal *Sc1* to the first switcher **67**, thereby controlling the first switcher **67**. Alternatively the controller **62** may be configured to receive the current notification signal *Sia*, generate the conduction command signal *Sc1* using the trigger signal *Str* and the current notification signal *Sia* and output the conduction command signal *Sc1* to the first switcher **67**, thereby controlling the first switcher **67**.

[0235] (b) The first reverse flow suppressor **69** is not limited to the configuration provided with a switcher such as a FET. Any configuration such as a schottky diode can be employed as long as it can suppress inflow of reverse current, and has low voltage drop when electric current flows in forward direction. The same applies to the second reverse flow suppressor **73**.

[0236] (c) In the aforementioned embodiments, the constant voltage $V_{cc}=5$ [V], the battery voltage $V_B=36$ [V], and the second constant voltage $V_{dd}=15$ [V]. These voltages are not limited to the above values, and may be other appropriate values depending on usage of the electric working machine.

[0237] As shown in FIG. **12**, the multiple-output power source **102** may include three battery packs (first battery pack **103**, second battery pack **104**, and third battery pack **105**), three voltage outputters (first voltage outputter **102a**, second voltage outputter **102b**, and third voltage outputter **102d**), and a reference voltage **102c**. The multiple-output power source **102** may output a first battery voltage V_{B1} ($V_{B1}=108$ [V]) from the first voltage outputter **102a**, output a third battery voltage V_{B3} ($V_{B3}=72$ [V]) from the third voltage outputter **102d**, and output the second battery voltage V_{B2} ($V_{B2}=36$ [V]) from the second voltage outputter **102b**.

[0238] In the aforementioned embodiments, only the converter that steps down the voltage is provided. The electric working machine of the present disclosure may be provided with a converter that steps up the voltage. For example, in the second embodiment, the third converter **93** steps down the battery voltage V_B to the second constant voltage V_{dd} . As another form, after the third converter **93** steps up the battery voltage V_B (36 [V]) to a third constant voltage V_{ee} (for example, 51 [V]), a fifth converter (not shown) may step down the third constant voltage V_{ee} to the second constant voltage V_{dd} (15 [V]). The third constant voltage V_{ee} has higher voltage than the battery voltage V_B , and can be used as a power source of a high side FET. Also, presence of the converter that steps up the voltage allows generation of the second constant voltage V_{dd} , even if the battery voltage V_B falls below the second constant voltage V_{dd} (15 [V]) due to failure of the battery pack **100**, for example.

[0239] (d) The electric working machine to which the present disclosure is applicable is not limited to a rechargeable impact driver, and may be, for example, an electric hammer, an electric hammer drill, an electric drill, an electric driver, an electric wrench, an electric reciprocating

saw, an electric jigsaw, an electric cutter, an electric chain-saw, and electric planer, an electric tacker, an electric nailer, an electric hedge trimmer, an electric lawn mower, an electric grass trimmer, an electric grass cutter, an electric cleaner, an electric blower, an electric grinder, an electric impact driver, an electric circular saw, an electric hammer driver, etc.

[0240] (e) Functions of one component in the aforementioned embodiments may be distributed as two or more components, and functions of two or more components may be integrated as one component. At least a part of the configuration of the aforementioned embodiments may be replaced with known configurations having the same function. A part of the aforementioned embodiments may be omitted. At least a part of the configuration of the aforementioned embodiment may be added to or may replace the configuration of the other embodiment. It should be noted that any and all modes that are encompassed in the technical ideas defined by the languages in the scope of the claims are embodiments of the present disclosure.

What is claimed is:

1. An electric working machine comprising:

a battery pack configured to output power-supply power;
a battery port configured to detachably attach to the battery pack;

a motor configured to be driven with the power-supply power;

a controller configured to selectively switch operation state of the controller to a control operation state and a low power operation state, the controller in the control operation state controlling the motor, the controller in the low power operation state consuming electric power smaller than power consumption of the controller in the control operation state,

an operation state determiner configured to determine the operation state of the controller; and

a control power source including a first current path, a second current path, a first converter, and a second converter,

the first current path being a part of a current path from the battery port to the controller,

the second current path being coupled in parallel to the first current path,

the first converter being (i) provided in the first current path, and (ii) configured to output a first control current based on the power-supply power, the first control current having a maximum value corresponding to a maximum consumption current value of the controller in the control operation state,

the second converter being (i) provided in the second current path, and (ii) configured to output a second control current based on the power-supply power, the second control current having a maximum value (i) smaller than the maximum value of the first control current and (ii) corresponding to a maximum consumption current value of the controller in the low power operation state,

the control power source being configured to transition to a first conversion state in response to the operation state determiner determining that the controller is in the control operation state, the control power source in the first conversion state being configured to supply the first control current to the controller via the first current path, and

- the control power source being configured to transition to a second conversion state in response to the operation state determiner determining that the controller is in the low power operation state, the control power source in the second conversion state being configured to (i) stop operation of the first converter, and (ii) supply the second control current to the controller via the second current path.
2. An electric working machine comprising:
 a driving device configured to be driven with power-supply power from a power source;
 a controller configured to selectively switch an operation state of the controller to one of multiple operation states, the multiple operation states including a control operation state and a low power operation state, the controller in the control operation state being configured to control the driving device, the controller in the low power operation state being configured to consume electric power smaller than power consumption of the controller in the control operation state;
 an operation state determiner configured to determine the operation state of the controller; and
 a control power source including a first converter and a second converter,
 the first converter being configured to output a first control current based on the power-supply power, the first control current having a maximum value corresponding to a maximum consumption current value of the controller in the control operation state,
 the second converter being configured to output a second control current based on the power-supply power, the second control current having a maximum value (i) smaller than the maximum value of the first control current and (ii) corresponding to a maximum consumption current value of the controller in the low power operation state,
 the control power source being configured to transition to a first conversion state in response to the operation state determiner determining that the controller is in the control operation state, the control power source in the first conversion state being configured to supply the first control current to the controller, and
 the control power source being configured to transition to a second conversion state in response to the operation state determiner determining that the controller is in the low power operation state, the control power source in the second conversion state being configured to (i) stop operation of the first converter, and (ii) supply the second control current to the controller.
3. The electric working machine according to claim 2, wherein
 the control power source is configured to transition to the first conversion state in response to a user manipulating the electric working machine.
4. The electric working machine according to claim 2, wherein
 the first converter includes a first outputter, and
 the electric working machine includes a first reverse flow suppressor configured to suppress inflow of reverse current to the first outputter.
5. The electric working machine according to claim 2, wherein
 the control power source includes a first current path and a second current path,
 the first current path is a part of a current path from the power source to the controller,
 the first converter is provided in the first current path,
 the second current path is coupled in parallel to the first current path,
 the second converter is provided in the second current path,
 the control power source in the first conversion state is configured to supply the first control current to the controller via the first current path, and
 the control power source in the second conversion state is configured to supply the second control current to the controller via the second current path.
6. The electric working machine according to claim 5, wherein
 the second converter includes a second outputter, and
 the electric working machine further comprises a second reverse flow suppressor provided in the second current path between the second converter and the controller, the second reverse flow suppressor being configured to suppress inflow of reverse current to the second outputter.
7. The electric working machine according to claim 5, wherein
 the power source is configured to output a power-supply voltage,
 the first converter is configured to output a first control voltage based on the power-supply voltage, the first control voltage being lower than the power-supply voltage, and
 the second converter is configured to output a second control voltage based on the power-supply voltage, the second control voltage being approximately equal to the first control voltage.
8. The electric working machine according to claim 5, wherein
 the operation state determiner is configured to receive a first state notification signal and a second state notification signal, the first state notification signal indicating that the operation state of the controller is the control operation state, the second state notification signal indicating that the operation state of the controller is the low power operation state,
 the operation state determiner is configured to determine that the operation state of the controller is the control operation state in response to receipt of the first state notification signal, and
 the operation state determiner being configured to determine that the operation state of the controller is the low power operation state in response to receipt of the second state notification signal.
9. The electric working machine according to claim 2, wherein
 the control power source includes a third current path, a bypass current path, and a common current path,
 the third current path is a part of a current path from the power source to the controller,
 the first converter is provided in the third current path,
 the bypass current path is couple in parallel to the third current path,
 the common current path has a first end coupled to the third current path and the bypass current path,
 the second converter is provided in the common current path,

the power source is configured to output a power-supply voltage,
 the first converter is configured to convert the power-supply voltage to a first control voltage,
 the first control voltage is lower than the power-supply voltage,
 the second converter is configured to convert the power-supply voltage or the first control voltage to a second control voltage,
 the second control voltage is lower than the first control voltage,
 the control power source in the first conversion state is configured to (i) operate the first converter and the second converter so that the second converter converts the first control voltage to the second control voltage, and (ii) supply the second control voltage to the controller, and
 the control power source in the second conversion state is configured to operate the second converter so that the second converter converts the power-supply voltage to the second control voltage.

10. The electric working machine according to claim **9**, wherein

the bypass current path is configured to receive a bypass current,
 the operation state determiner is configured to determine whether a value of the bypass current flowing through the bypass current path is larger than a predefined operation reference value,
 the operation state determiner is configured to determine that the controller is in the control operation state in response to the value of the bypass current being larger than the operation reference value, and
 the operation state determiner is configured to determine that the controller is in the low power operation state in response to the value of the bypass current being equal to or lower than the operation reference value.

11. The electric working machine according to claim **10**, wherein

the operation state determiner is configured to receive a first state notification signal and a second state notification signal, the first state notification signal indicating that the operation state of the controller is the control operation state, the second state notification signal indicating that the operation state of the controller is the low power operation state,
 the operation state determiner is configured to determine that the operation state of the controller is the control operation state in response to the value of the bypass current being larger than the operation reference value or in response to receipt of the first state notification signal, and

the operation state determiner is configured to determine that the operation state of the controller is the low power operation state (i) in response to the value of the bypass current being equal to or lower than the operation reference value and (ii) in response to receipt of the second state notification signal.

12. The electric working machine according to claim **2**, wherein

the power source includes a first voltage outputter and a second voltage outputter,
 the first converter is coupled to the first voltage outputter, and
 the second converter is coupled to the second voltage outputter.

13. The electric working machine according to claim **12**, wherein

the first voltage outputter is configured to output a first output voltage,
 the second voltage outputter is configured to output a second output voltage, and
 the first output voltage is higher than the second output voltage.

14. The electric working machine according to claim **13**, wherein

the power source further includes a third voltage outputter configured to output a third output voltage, and
 the second output voltage is lower than the third output voltage.

15. A method for supplying electric power to a controller of an electric working machine, the method comprising:

supplying a first control current from a first converter to the controller in response to the controller being in a control operation state, the first converter being configured to output the first control current based on power-supply power of the electric working machine, the first control current having a maximum value corresponding to a maximum consumption current value of the controller in the control operation state; and

supplying a second control current from a second converter to the controller in response to the controller being in a low power operation state, the second converter being configured to output the second control current based on the power-supply power, the second control current having a maximum value (i) smaller than the maximum value of the first control current and (ii) corresponding to a maximum consumption current value of the controller in the low power operation state.

* * * * *