



US 20150357741A1

(19) **United States**

(12) **Patent Application Publication**

Nazzaro et al.

(10) **Pub. No.: US 2015/0357741 A1**

(43) **Pub. Date: Dec. 10, 2015**

(54) **ELECTRONIC DEVICE WITH HIDDEN CONNECTOR**

(52) **U.S. Cl.**
CPC *H01R 13/44* (2013.01); *H01R 13/46* (2013.01)

(71) Applicant: **APPLE INC.**, Cupertino, CA (US)

(72) Inventors: **David I. Nazzaro**, Saratoga, CA (US);
Tyler S. Bushnell, Mountain View, CA (US);
Ibuki Kamei, San Jose, CA (US)

(57) **ABSTRACT**

(21) Appl. No.: **14/299,921**

(22) Filed: **Jun. 9, 2014**

An electronic device has a self-healing elastomer applied over one or more external electronic connectors. The self-healing elastomer may obscure the electronic connectors from the user as well as provide environmental protection for the connector and the electronic device. Electronic probes may temporarily penetrate the self-healing elastomer to mate with the electronic connector. After removal of the probes the self-healing elastomer may elastically reform and self-heal.

Publication Classification

(51) **Int. Cl.**
H01R 13/44 (2006.01)
H01R 13/46 (2006.01)

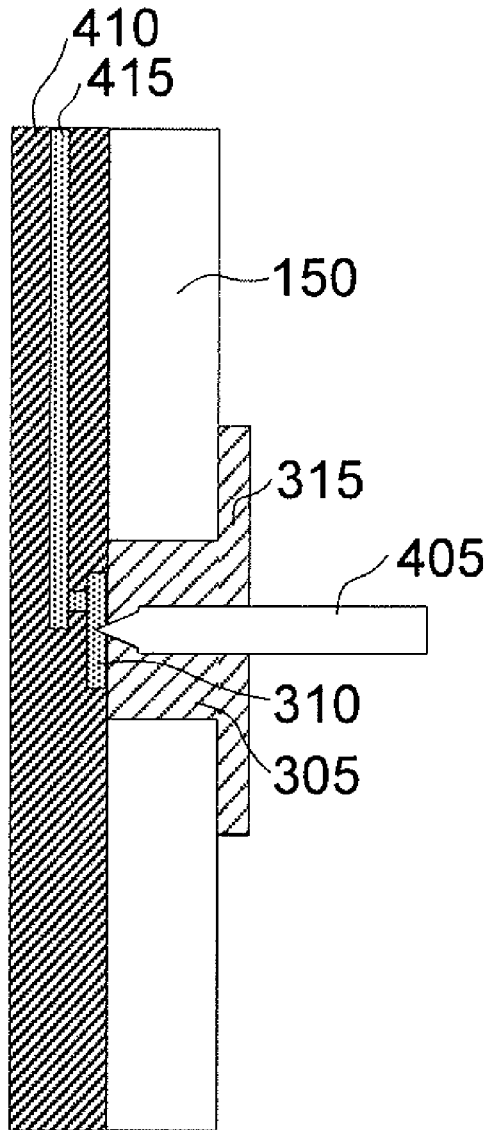

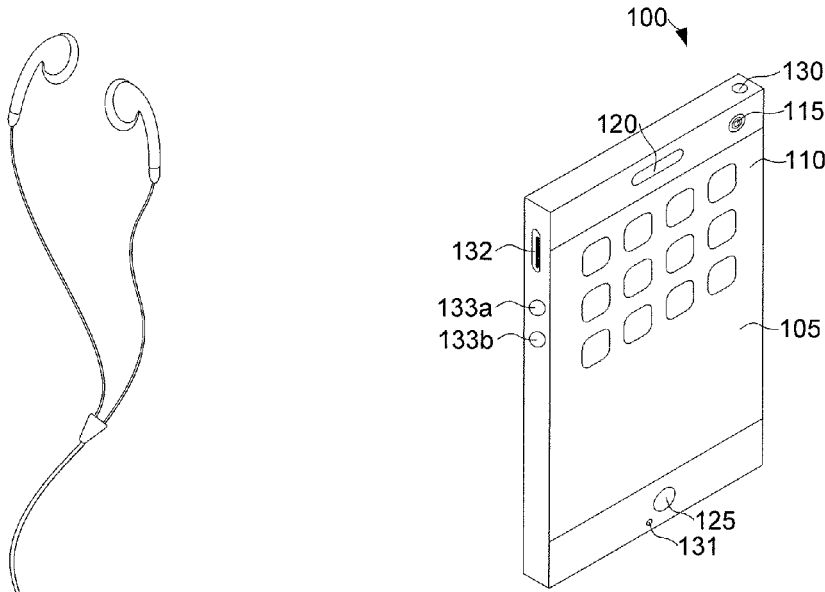

FIG. 1

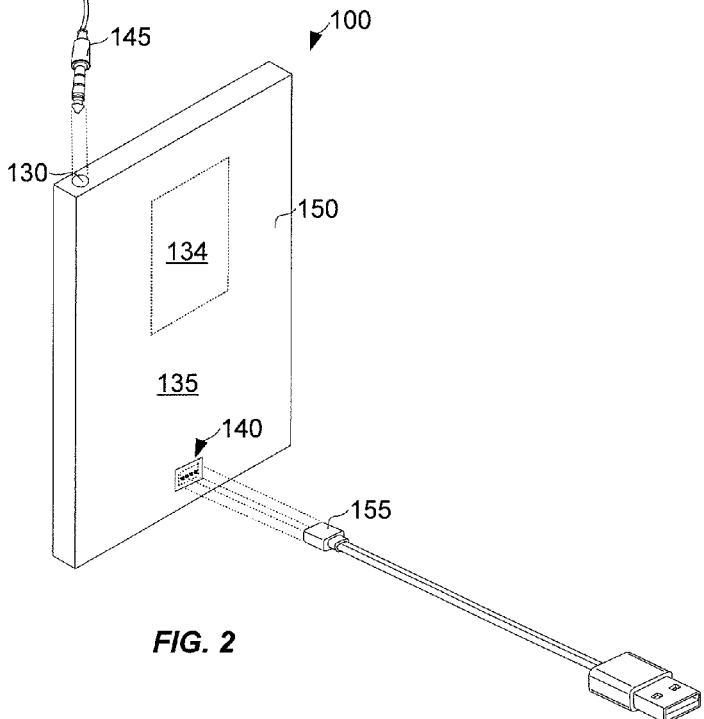

FIG. 2

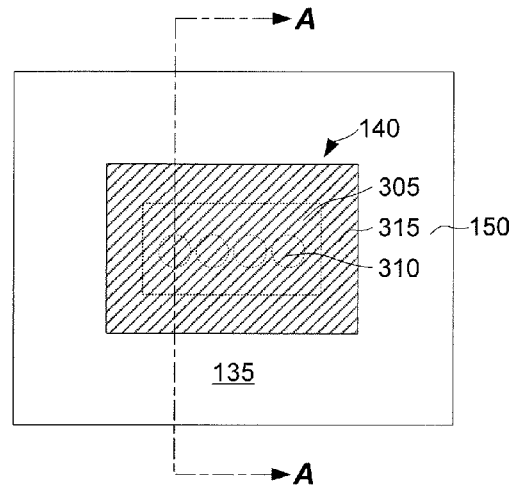

FIG. 3

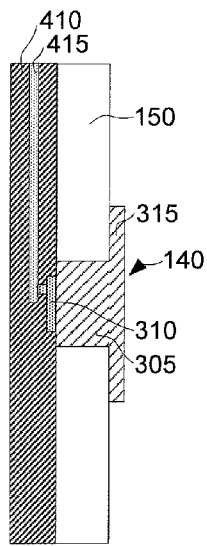

FIG. 4

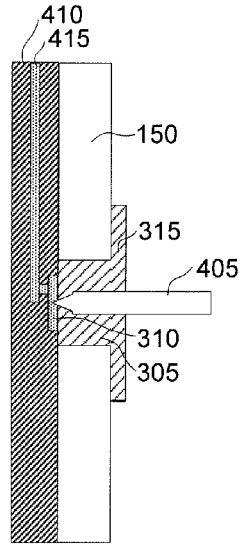

FIG. 5

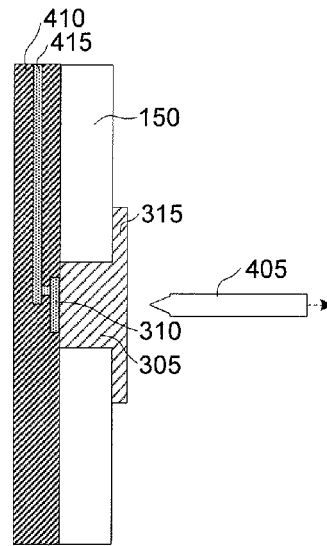

FIG. 6

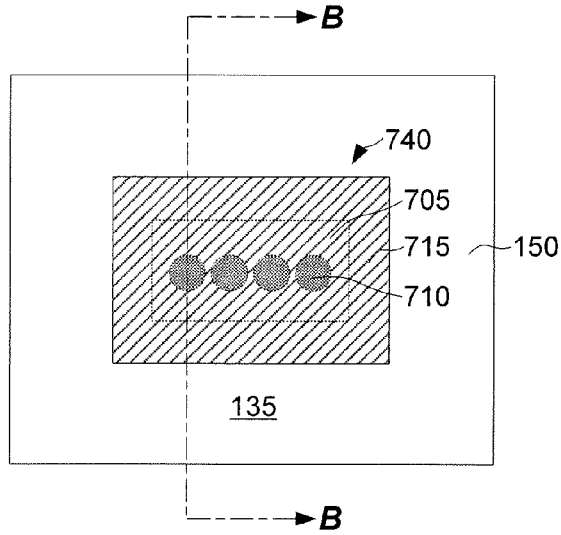

FIG. 7

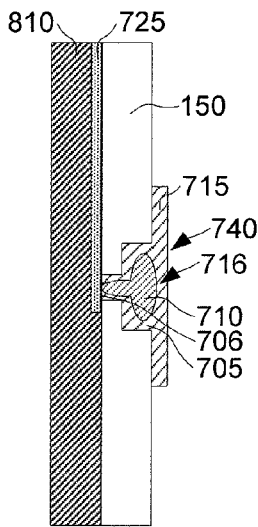

FIG. 8

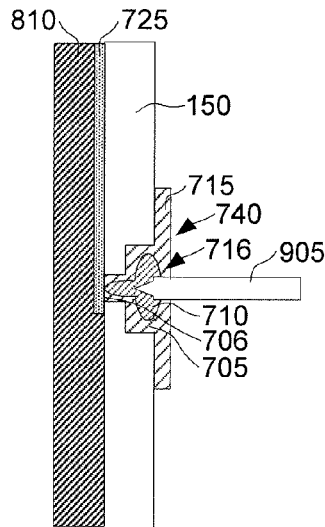

FIG. 9

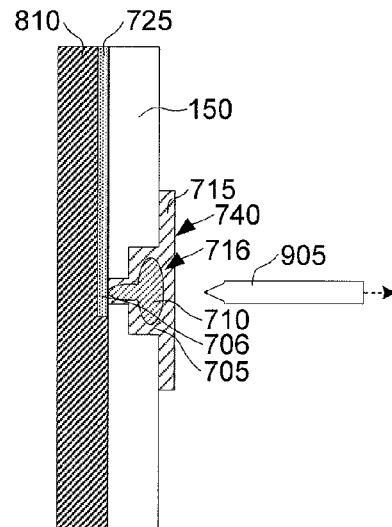

FIG. 10

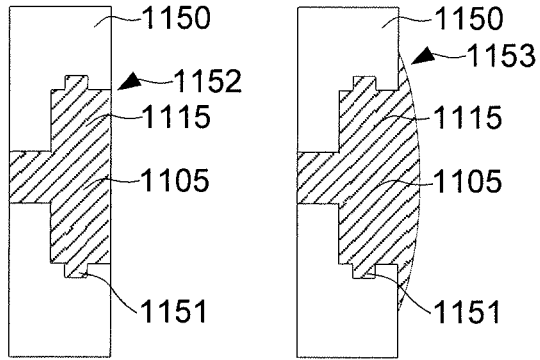

FIG. 11

FIG. 12

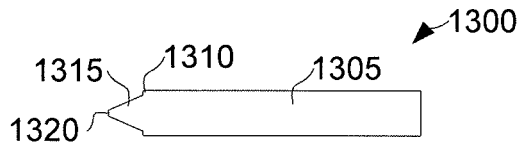

FIG. 13A

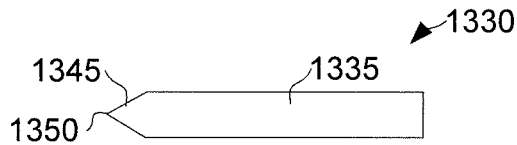

FIG. 13B

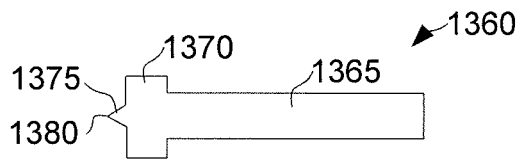

FIG. 13C

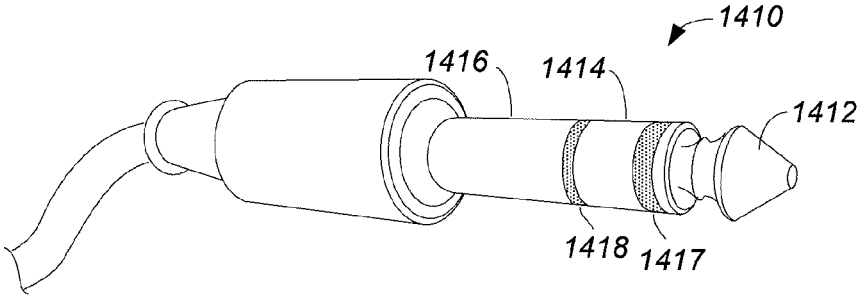

FIG. 14

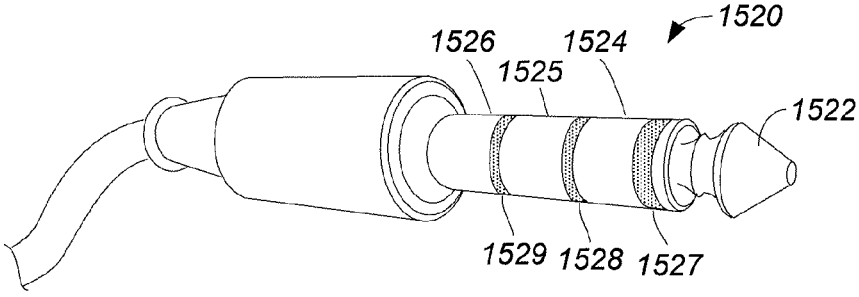

FIG. 15

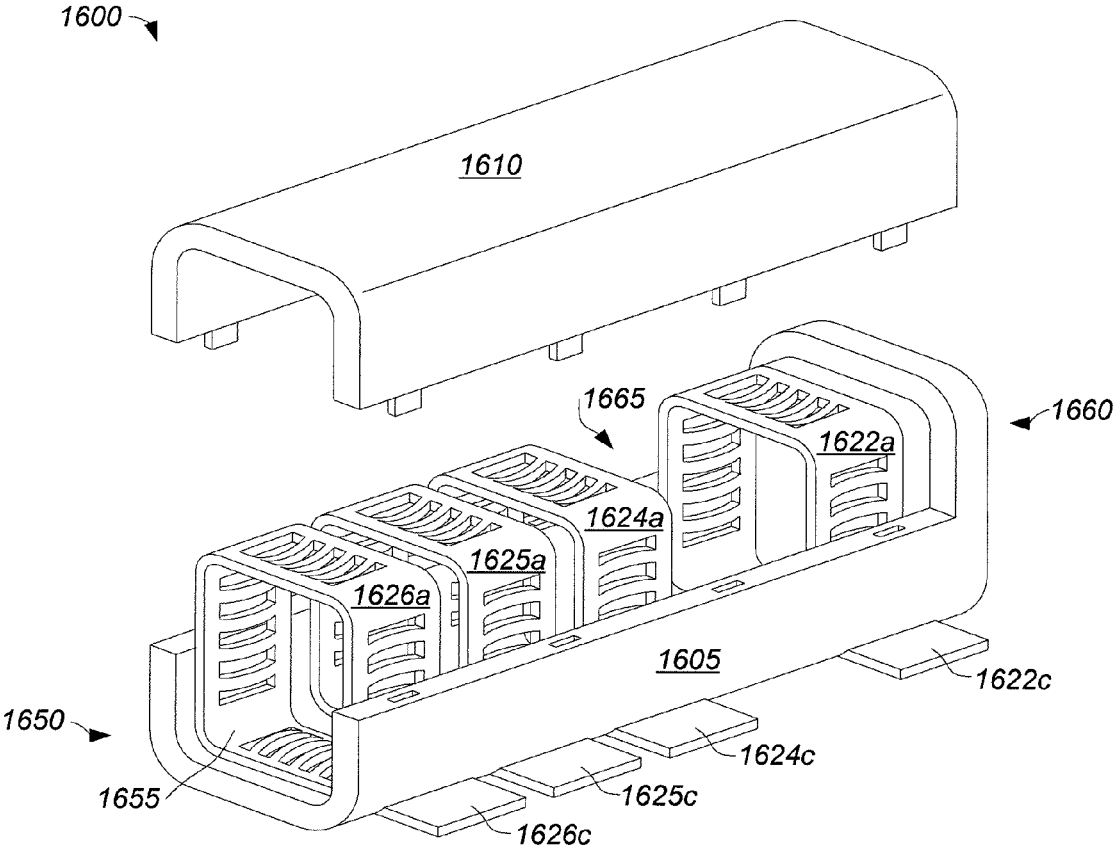

FIG. 16

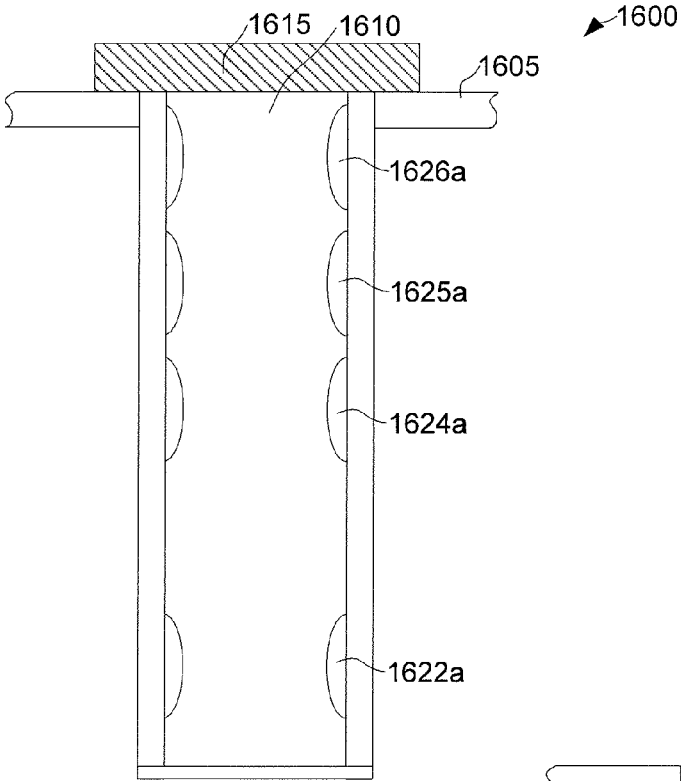

FIG. 17

1600

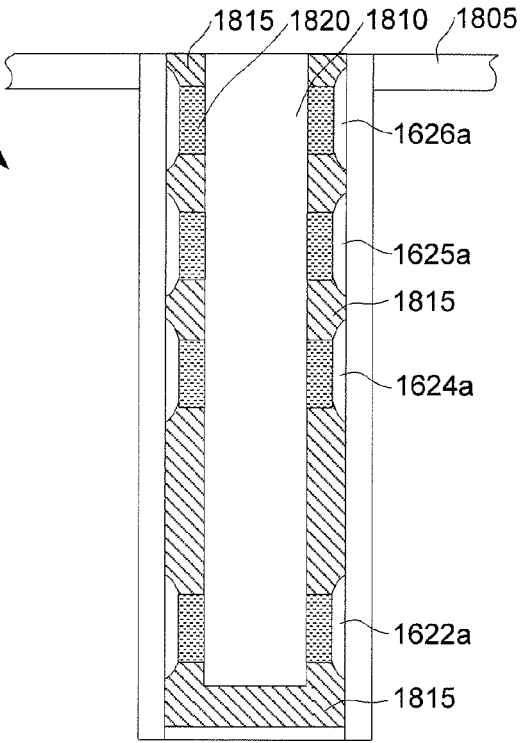

FIG. 18

+

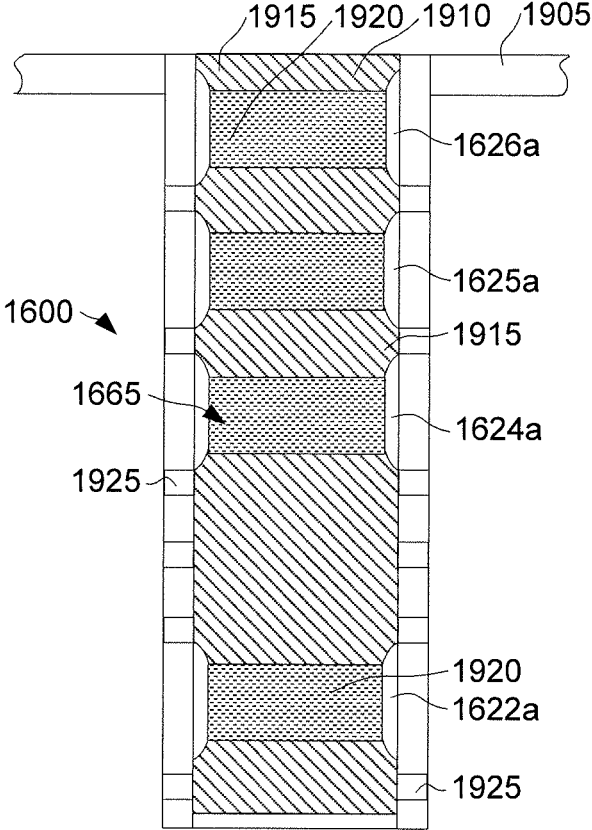

FIG. 19

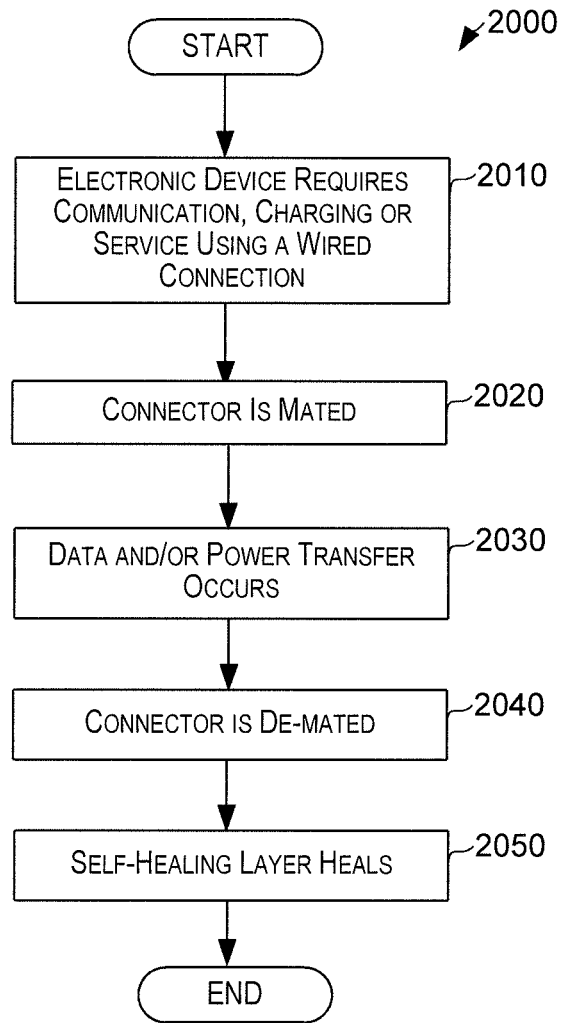

FIG. 20

ELECTRONIC DEVICE WITH HIDDEN CONNECTOR

FIELD

[0001] The present invention relates generally to electronic devices and in particular to electronic devices that include one or more electrical connectors that enable connection to an external device.

BACKGROUND

[0002] A wide variety of electronic devices are available for consumers today that employ a broad range of external electronic connectors to facilitate communication with other devices and/or charging of the device.

[0003] As an example, audio jack and data connectors are sometimes positioned on one or more of the external surfaces of an electronic device and mounted to a printed circuit board (PCB) within the device. As smart-phones, media players, charging stations and other electronic devices are reduced in size, external connectors may consume a large proportion of the outside surface of the device, marring its aesthetic appeal. Additionally, as electronic devices become more indispensable to their operators, the devices are with their operators more frequently and are more likely to be exposed to harsh environments that may damage the connectors and the electronic device.

[0004] For example, miniature portable media players may be equipped with wireless communication and/or charging systems to increase their appeal to consumers. As wireless connections become more and more prevalent, an electrical connector on a device may be used less frequently. In some applications electronic devices may still require at least one external electrical connector for data exchange or charging when a wireless connection is not available and/or for diagnostic and repair purposes. In addition, the portable media player may frequently be with the consumer and exposed to rain and other harsh environments.

SUMMARY

[0005] Embodiments of the invention pertain to electrical connectors for use with a variety of electronic devices. In some embodiments, the electrical connectors are configured to be equipped with a self-healing barrier layer providing an aesthetic covering for the connector as well as protection for the contacts within the connector and for circuitry within the device housing.

[0006] One particular embodiment employs a connector having a plurality of contacts accessible through an opening in the housing of the electronic device. The connector is operatively coupled to electronic circuitry within the housing. A layer of self-healing elastomer covers the opening in the housing providing an aesthetic covering for the connector as well as environmental protection for the connector and the electronic device. In some embodiments the self-healing elastomer extends over the housing beyond the opening. In other embodiments the self-healing elastomer may be disposed only within the opening in the housing. One or more electrical probes may temporarily penetrate the self-healing elastomer to make contact with the connector contacts. After the electrical probes are removed, the self-healing elastomer may heal, regaining all, most or at least some of its aesthetic and protective properties.

[0007] Other embodiments may incorporate one or more conductively doped regions within the self-healing elastomer. The conductively doped regions may be disposed over each of the plurality of contacts of the connector. The electrical probes may then penetrate the self-healing elastomer and make contact with the conductively doped regions. The conductively doped regions may include conductive particulates such as, but not limited to, silver, gold, palladium, copper or metal coated spheres. In this embodiment, electrical current may pass through the electrical probe, through the conductively doped region to the connector contact.

[0008] In further embodiments an electronic connector with a plurality of contacts may be installed within the housing of an electronic device. The plurality of contacts may be accessible through an opening in the housing. The connector may have a cavity wherein the plurality of contacts are sequentially positioned within and spaced apart along the depth of the cavity. A layer of self-healing elastomer may be disposed over each of the plurality of contacts.

[0009] To better understand the nature and advantages of the present invention, reference should be made to the following description and the accompanying figures. It is to be understood, however, that each of the figures is provided for the purpose of illustration only and is not intended as a definition of the limits of the scope of the present invention. Also, as a general rule, and unless it is evident to the contrary from the description, where elements in different figures use identical reference numbers, the elements are generally either identical or at least similar in function or purpose.

BRIEF DESCRIPTION OF THE DRAWINGS

[0010] FIG. 1 is a front perspective view of an electronic device according to an embodiment of the invention;

[0011] FIG. 2 is a rear perspective view of the electronic device shown in FIG. 1 with an audio connector and a data connector;

[0012] FIG. 3 is a plan view of the electrical connector shown in FIG. 1 covered by a self-healing elastomer and accessible through an opening in the device housing;

[0013] FIG. 4 is a cross-sectional view of the electrical connector shown in FIG. 3 before probe penetration;

[0014] FIG. 5 is a cross-sectional view of the electrical connector shown in FIG. 3 during probe penetration;

[0015] FIG. 6 is a cross-sectional view of the electrical connector shown in FIG. 3 after probe penetration;

[0016] FIG. 7 is a plan view of an electrical connector covered by a self-healing elastomer with conductively doped regions according to an embodiment of the invention;

[0017] FIG. 8 is a cross-sectional view of the electrical connector shown in FIG. 7 before probe penetration;

[0018] FIG. 9 is a cross-sectional view of the electrical connector shown in FIG. 7 during probe penetration;

[0019] FIG. 10 is a cross-sectional view of the electrical connector shown in FIG. 7 after probe penetration;

[0020] FIG. 11 is a cross-sectional view of an opening in a housing filled with a self-healing elastomer according to an embodiment of the invention;

[0021] FIG. 12 is a cross-sectional view of an opening in a housing filled with a self-healing elastomer according to an embodiment of the invention;

[0022] FIG. 13A is a side view of an electrical probe according to an embodiment of the invention;

[0023] FIG. 13B is a side view of an electrical probe according to an embodiment of the invention;

[0024] FIG. 13C is a side view of an electrical probe according to an embodiment of the invention;

[0025] FIG. 14 is a perspective view of an audio plug connector according to an embodiment of the invention;

[0026] FIG. 15 is a perspective view of an audio plug connector according to an embodiment of the invention;

[0027] FIG. 16 is an exploded perspective view of an audio receptacle connector according to an embodiment of the invention;

[0028] FIG. 17 is a cross-sectional view of an audio connector installed in a housing having a self-healing elastomer barrier layer according to an embodiment of the invention;

[0029] FIG. 18 is a cross-sectional view of an audio connector installed in a housing having a self-healing elastomer barrier layer with conductively doped regions over the connector contacts according to an embodiment of the invention;

[0030] FIG. 19 is a cross-sectional view of an audio connector installed in a housing having a self-healing elastomer barrier layer with conductively doped regions over the connector contacts according to an embodiment of the invention; and

[0031] FIG. 20 is a method for mating a data or audio connector with an external connector on an electronic device having a self-healing layer.

DETAILED DESCRIPTION

[0032] Certain embodiments of the present invention relate to electronic devices. While the present invention can be useful for a wide variety of electronic devices, some embodiments of the invention are particularly useful for electronic devices that have a layer of self-healing elastomer disposed over one or more external electronic connectors, as described in more detail below.

[0033] FIG. 1 depicts a simplified diagram of an example electronic device 100 that may incorporate an embodiment. Device 100 is used for illustration only; the concepts/techniques of the invention can be employed in myriad electronic devices. For example, it is understood that embodiments of the invention are not limited to smartphones and may be employed in any type of electronic device including, but not limited to, wrist watches, portable media players, notebook computers, docking stations, desktop computers, portable radios, televisions, and set top boxes.

[0034] In the embodiment depicted in FIG. 1, electronic device 100 includes a front face 105 having a display screen 110, a sensor 115, a speaker 120, a home button 125, an audio connector 130 and a microphone 131. In some embodiments sensor 115 may be a camera, an infra-red detector or an ultrasonic detector. Although the embodiment in FIG. 1 shows only one display screen, sensor, speaker, home button, audio connector and microphone, it is understood that myriad configurations and quantities of these features are possible without departing from the invention. Electronic device 100 also includes on/off switch 132 and volume buttons 133a, 133b.

[0035] FIG. 2 depicts a simplified diagram of the rear of electronic device 100. Electronic device 100 includes housing 150 configured to be a rectangular prism having a back face 135 positioned opposite front face 105. In other embodiments, housing 150 may be shaped differently, for example in one embodiment the housing is curved and shaped to be worn on a user's wrist. Electronic circuitry 134 is disposed within housing 150 and is coupled to display screen 110, sensor 115, speaker 120, home button 125, audio connector 130, micro-

phone 131, on/off switch 132 and volume buttons 133a, 133b. FIG. 2 also depicts an audio plug connector 145 that is mateable with audio connector 130, and data plug connector 155 that is mateable with data connector 140. In certain embodiments, one or more of connectors 130, 140 may employ an embodiment of the invention. Embodiments of the invention may be used on a variety of different electrical connectors.

[0036] FIG. 3 depicts a simplified close up plan view of data connector 140 and a portion of housing 150 (see FIG. 2), and FIG. 4 illustrates a simplified cross-section (see section A-A in FIG. 3) through one of plurality of contacts 310. Housing 150 has an opening 305. Data connector 140 is operatively coupled to electronic circuitry 134 (see FIG. 2) within housing 150. Data connector 140 includes plurality of contacts 310 disposed on a substrate 410 and accessible through opening 305. Although plurality contacts 310 are illustrated as four circular pads arranged in a linear pattern, the plurality of contacts may be of any number, any shape and any pattern. Further, in some embodiments, plurality of contacts 310 may not be pads, but may be other electrical contacts, such as, but not limited to blade-type connectors, sliding-type connectors or cylindrical-type pin and socket connectors. Substrate 410 may be a part of electronic circuitry 134 (see FIG. 2) disposed within housing 150.

[0037] Unlike in a typical electrical connector in which the contacts are exposed for an electrical connection to a corresponding connector, contacts 310 are buried beneath a layer of self-healing elastomer 315 which covers opening 305 and plurality of contacts 310. Elastomer 315 thus provides a strong environmental seal that protects contacts 310 from the environment including dust, debris, moisture and gas and prevents the contacts from being accessed without a tool or corresponding connector that can penetrate self-healing elastomer 315. In some embodiments, self-healing elastomer 315 may be filled with a pigment and blended with housing 150 such that it may appear contiguous with the housing and be substantially imperceptible thus hiding the connector such that a user may not even realize the electronic device even has an external connector.

[0038] In some embodiments self-healing elastomer 315 extends over housing 150, beyond opening 305. In other embodiments self-healing elastomer 315 may be disposed only within opening 305 and may not extend over housing 150. The size and thickness of self-healing elastomer 315 may depend on the size of opening 305, which in turn is dependent on the size and shape of connector 140 and the thickness of housing 150. In some embodiments where it is desirable for electronic device 100 to be thin, self-healing elastomer 315 may be less than 0.5 mm thick. In other embodiments self-healing elastomer 315 may be between 0.5 mm to 0.1 mm thick. In further embodiments self-healing elastomer 315 may be between 0.1 mm to 0.2 mm thick. In yet further embodiments self-healing elastomer 315 may be greater than 0.2 mm thick. In other embodiments the thickness of self-healing elastomer 315 may be greater than 0.5 mm.

[0039] Self-healing elastomer 315 may be a polymer with elastic properties such as a low Young's modulus and a high failure strain. In further embodiments, self-healing elastomer 315 may comprise a silicone material, also known as a polymerized siloxane. In some embodiments, the polymerized siloxane may be mixed inorganic-organic polymers with the chemical formula $[R_2SiO]_n$, where R is an organic group such as methyl, ethyl, or phenyl. In these embodiments the

silicone material may comprise an inorganic silicon-oxygen backbone with organic side groups attached to the silicon atoms. In further embodiments self-healing elastomer 315 may include one or more materials that change its color. In some embodiments self-healing elastomer 315 may approximately match a color of housing 150. Other formulations may be used without departing from the invention.

[0040] As illustrated in FIG. 4, plurality of contacts 310 may be disposed on substrate 410 and connected by electrical traces 415 to electronic circuitry 134 (see FIG. 2). During normal operation self-healing elastomer 315 may provide an aesthetic cover over connector 140 and opening 305. That is, the user may not be able to discern connector 140 upon a casual inspection of electronic device 100. In some embodiments, self-healing elastomer 315 may provide a protective barrier for and/or a hermetic around opening 305 thus providing protection for connector 140, contacts 310 and housing 150 against debris, water, water vapor, and/or gasses. moisture and such that water and debris may not penetrate the self-healing elastomer.

[0041] To manufacture electronic device 100 with self-healing elastomer 315, the self-healing elastomer may be applied to housing 150 in liquid form and cured in place. In other embodiments, self-healing elastomer 315 may be insert-molded on housing 150. In further embodiments, self-healing elastomer 315 may be pre-molded and subsequently attached to housing 150 with an adhesive or by other means. In some embodiments, housing 150 includes one or more retention features formed in the sidewall of the housing around opening 150 that helps improve adhesion between the elastomer and sidewall thus better secure self-healing elastomer 315 to the housing as described below in conjunction with FIG. 11. Myriad methods may be used to form self-healing elastomer 315 and attach it to housing 150 without departing from the invention.

[0042] Reference is now made to FIGS. 5 and 6, which illustrate simplified cross-sectional views of connector 140 and self-healing elastomer 315 during penetration by an electronic probe 405 and after removal of the electronic probe, respectively. In some embodiments, electronic probe 405 may be integrated within data plug connector 155 (see FIG. 2) while in other embodiments it may be a separate device. In further embodiments there may be as many electronic probes within data plug connector 155 (see FIG. 2) as there are contacts 310.

[0043] As illustrated in FIGS. 5 and 6, electronic probe 405 may be relatively thin and generally pointed with a sharp tip to penetrate self-healing elastomer 315 and make an electrical connection with contacts 310. In some embodiments, contacts 310 may be metallic and may be plated with one or more layers of metal including, but not limited to gold, silver, palladium or tin.

[0044] When electrical probe 405 is engaged with connector contact 310, electrical current may pass between electrical probe 405 and contact 310 through trace 415 to electrical circuitry 134 (see FIG. 2) disposed within housing 150. In some embodiments data and/or power may be transferred to and from electronic device 100 by one or more electrical probes 405 disposed within data plug 155 (see FIG. 2). More specifically, in some embodiments plurality of contacts 310 may comprise a power contact, a ground contact and a pair of data contacts. Other embodiments may have different configurations for contacts 310. For example, in one embodiment contacts 310 may not transfer data or power, but may simply

be shorted together to perform a reset function or other operation on electronic device 100 (see FIG. 1). Contacts 310 may have myriad configurations and purposes without departing from the scope of the invention.

[0045] FIG. 6 illustrates self-healing elastomer 315 after electrical probe 405 has been removed. As illustrated, self-healing elastomer 315 heals in the penetration region after removal of electrical probe 405. As defined herein, heals shall mean that self-healing elastomer 315 may reseal itself and regain at least some of its aesthetic, mechanical and/or protective properties. That is, in some embodiments self-healing elastomer 315 may elastically resume its prior shape, resuming its aesthetic appearance prior to penetration. In further embodiments, self-healing elastomer 315 may also resume providing a water resistant barrier and/or debris protection for contacts 310 and housing 150.

[0046] Because of its self-healing nature, elastomer 315 may be penetrated multiple times by electrical probe 405 while retaining its protective properties. In some embodiments, self-healing elastomer may “heal” by reforming chemical bonds, regaining at least some of its mechanical properties in the penetration region. In yet further embodiments, self-healing elastomer 315 may reform covalent bonds in the penetration region and regain at least 30 percent of its tensile strength in the penetration region. In other embodiments, it may regain at least 50 percent of its tensile strength in the penetration region. In further embodiments it may regain at least 70 percent of its tensile strength in the penetration region. In yet further embodiments it may regain at least 90 percent of its tensile strength in the penetration region. In some embodiments the recovery of tensile strength may be temperature dependent. For example, in some embodiments recovery may occur between 44 and 92 degrees centigrade. In other embodiments the recovery of tensile strength may be temperature dependent and may improve with an increase in temperature. In some embodiments the recovery of tensile strength may occur between 52 and 84 degrees centigrade. In other embodiments the recovery of tensile strength may occur between 60 and 76 degrees centigrade. In further embodiments the recovery of tensile strength may occur at approximately 68 degrees centigrade. In some embodiments self-healing elastomer 315 may be applied to housing 150, and while in a partially cured condition it may be penetrated by electrical probe 405 and fully cured after removal of the electrical probe.

[0047] FIG. 7 depicts a simplified close up plan view of another embodiment of the invention showing data connector 740 having a plurality of contacts 710 and a self-healing elastomer 715. Data connector 740 may be employed on electronic device 100 (see FIG. 1) or any other electronic device. Electronic device 100 is used for example only and is not intended to be limiting. In this embodiment, plurality of contacts 710 are conductively doped regions 716, which will be described in more detail below. FIG. 8 illustrates a simplified cross-section (see section B-B in FIG. 7) through one of plurality of contacts 710. Housing 150 has an opening 705. Data connector 740 is operatively coupled to electronic circuitry within housing 150. Data connector 740 includes a plurality of contacts 710 connected to substrate 810 and accessible through opening 705. Although plurality contacts 710 are illustrated as four circular conductively doped regions 716 arranged in a linear pattern, the plurality of contacts may

be of any number, any shape and any pattern. Substrate **810** may be a part of electronic circuitry **134** (see FIG. 2) disposed within housing **150**.

[0048] A layer of self-healing elastomer **715** covers opening **705** and plurality of contacts **710**. In some embodiments self-healing elastomer **715** extends over housing **150**, beyond opening **705**. In other embodiments self-healing elastomer **715** may be disposed only within opening **705** and may not extend over housing **150**. The size and thickness of self-healing elastomer **715** may depend on the size of opening **705**, which in turn is dependent on the size and shape of connector **740** and the thickness of housing **150**. Self-healing elastomer **715** may entirely cover opening **705** such that plurality of contacts **710** cannot be seen. In further embodiments, self-healing elastomer **715** may be filled with a pigment and blended with housing **150** such that it may appear contiguous with the housing and substantially imperceptible. In some embodiments where the thickness of the electronic device is critical, self-healing elastomer **715** may be less than 0.5 mm thick. In other embodiments self-healing elastomer **715** may be between 0.5 mm to 0.1 mm thick. In further embodiments self-healing elastomer **715** may be between 0.1 mm to 0.2 mm thick. In yet further embodiments self-healing elastomer **715** may be greater than 0.2 mm thick. In other embodiments the thickness of self-healing elastomer **715** may be greater than 0.5

[0049] MM.

[0050] As discussed above, self-healing elastomer **715** may be a polymer with elastic properties such as a low Young's modulus and a high failure strain. In further embodiments self-healing elastomer **715** may include one or more materials that change its color. In some embodiments self-healing elastomer **715** may approximately match a color of housing **150**. Other formulations may be used without departing from the invention.

[0051] To manufacture electronic device **100** (see FIG. 1) with self-healing elastomer **715**, the self-healing elastomer may be applied to housing **150** in liquid form and cured in place. In other embodiments, self-healing elastomer **715** may be insert-molded on housing **150**. In further embodiments, self-healing elastomer **715** may be pre-molded and subsequently attached to housing **150** with an adhesive or by other means. To form plurality of contacts **710** using conductively doped regions **716**, conductive particulates such as, but not limited to, silver, gold, palladium, copper or metal coated spheres may be introduced into self-healing elastomer **715**.

[0052] More specifically, in one embodiment, electrically conductive particulates may be dispersed in self-healing elastomer **715** by a dispenser or other method before it is cured. In another embodiment a mixture of an elastomer and conductive particulates may be dispersed in self-healing elastomer **715** by a dispenser or other method before it is cured. In other embodiments, conductively doped regions **716** may be formed by first casting or molding the conductively doped regions, then forming self-healing elastomer **715** around the conductively doped regions. In yet further embodiments, self-healing elastomer **715** and conductively doped regions **716** may be manufactured from multiple sequentially deposited layers in a laminate format. That is, in one embodiment each layer may be 0.1 mm thick and thus a 0.5 mm thick self-healing elastomer **715** may be made from approximately five layers. The layers may employ the self-healing nature of elastomer **715** to bond together. Myriad methods may be used to form self-healing elastomer **715** and attach it to housing

150 without departing from the invention. Conductively doped regions **716** may be in electrical contact with an exposed region **706** of trace **725**. Conductively doped regions **716** may not be visible from the outside of electronic device **100** (see FIG. 1).

[0053] FIG. 8 illustrates a cross-sectional view self-healing elastomer **715** on device **100** (see FIG. 1) while in a normal operating state, and FIGS. 9 and 10 illustrate cross-sectional views of the self-healing elastomer during penetration by electronic probe **905** and after removal of the electronic probe, respectively. In some embodiments, electronic probe **905** may be integrated within data plug connector **155** (see FIG. 2) while in other embodiments it may be a separate device. In further embodiments there may be as many electronic probes within data plug connector **155** (see FIG. 2) as there are contacts **710**.

[0054] As illustrated in FIG. 8, plurality of contacts **710** may be connected to substrate **810** and coupled by electrical traces **725** to electronic circuitry **134** (see FIG. 2). During normal operation self-healing elastomer **715** may provide an aesthetic cover over connector **740** including plurality of contacts **710** and opening **705**. That is, one may not be able to discern connector **740** upon a casual inspection of electronic device **100** (see FIG. 1).

[0055] In other embodiments, self-healing elastomer **715** may provide moisture and debris protection for connector **740**, contacts **710** and housing **150** such that water and debris may not penetrate the self-healing elastomer. In further embodiments, self-healing elastomer **715** may provide a barrier against water vapor and in yet further embodiments may provide a hermetic seal (i.e., impervious to gasses). Self-healing elastomer **715** may be sufficiently bonded to housing **150** such that the self-healing elastomer also provides a protective barrier for opening **705** against debris, water, water vapor, and/or gasses.

[0056] As illustrated in FIGS. 9 and 10 electronic probe **905** may be generally pointed with a sharp tip to penetrate self-healing elastomer **715** and make an electrical connection with contacts **710**. In this embodiment, contacts **710** may consist of one or more conductively doped regions **716** within self-healing elastomer **715** and may be disposed over one or more of each of exposed regions **706** of traces **725**. In some embodiments, exposed regions **706** may be metallic and may be plated with one or more layers of metal including, but not limited to gold, silver, palladium or tin.

[0057] When electrical probe **905** is engaged with contact **710**, electrical current may pass through electrical probe **905**, through conductively doped region **716** to exposed region **706** and through trace **725** to electrical circuitry **134** (see FIG. 2) disposed within housing **150**. Electrical conduction within conductively doped regions **716** may occur by conduction from one conductive particle to another conductive particle. In some embodiments data and/or power may be transferred to and from electronic device **100** by one or more electrical probes **905** disposed within data plug **155** (see FIG. 2). More specifically, in some embodiments plurality of contacts **710** may comprise a power contact, a ground contact and a pair of data contacts. Other embodiments may have different configurations for contacts **710**. For example, in one embodiment contacts **710** may not transfer data or power, but may simply be shorted together to perform a reset function or other operation on electronic device **100** (see FIG. 1). Contacts **710** may have myriad configurations and purposes without departing from the scope of the invention.

[0058] FIG. 10 illustrates self-healing elastomer 715 after electrical probe 905 has been removed. As discussed above, self-healing elastomer 715 heals in the penetration region after removal of electrical probe 905. Further, in some embodiments, conductively doped regions 716 may also include a self-healing elastomer that heals after removal of probe 905. The healing may restore all or some of the aesthetic, protective and/or mechanical properties of self-healing elastomer 715 and conductively doped regions 714.

[0059] In another embodiment, self-healing elastomer 715 may contain one or more conductively doped regions 716 for the purposes of improving and/or enhancing electrical contact between electrical probe 905 and exposed region 706 of trace 725. More specifically, in such embodiments, electrical probe 905 may partially or nearly contact exposed region 706 and conductively doped region 716 may make the electrical connection more reliable and consistent by compressing conductive particulates against the electrical probe and the exposed region.

[0060] FIG. 11 illustrates another embodiment of a housing 1150 that may be employed on an electronic device such as device 100 (see FIG. 1). This embodiment includes one or more retention features 1151 that are formed in one or more sidewalls of opening 1105 that may provide access to an electronic connector such as connector 140 (see FIG. 1). Similar to the previous embodiments, opening 1105 is filled with self-healing elastomer 1115 such that one or more probes may temporarily penetrate it to access one or more contacts (not shown) of the electrical connector. Self-healing elastomer 1115 may or may not contain conductively doped regions, as discussed above. In addition, in this particular embodiment, edges 1152 of self-healing elastomer 1115 are flush with housing 1150.

[0061] Retention features 1151 formed in sidewalls of opening 1105 may improve the adhesion of self-healing elastomer 1115 to housing 1150. In some embodiments, retention features 1151 may be formed by an injection molding process while in other embodiments the features may be formed by a post-processing operation on housing 1150 such as machining, melting or grinding. In further embodiments, other manufacturing methods may be used to form retention features 1151. Improved adhesion of self-healing elastomer 1115 may result in more reliable retention of the self-healing elastomer in housing 1150. Additionally, retention features 1151 may result in an improved barrier against water, water vapor, debris and/or gas penetration by creating an improved mechanical lock between self-healing elastomer 1115 and housing 1150 such that delamination does not occur. In further embodiments retention features 1151 may be different than those illustrated and may be a roughened surface or other type of mechanical locking feature. In other embodiments, a primer or surface treatment may be used on housing 1150 prior to application of self-healing elastomer 1115 to improve the adhesion of the self-healing elastomer to the housing.

[0062] Edges 1152 of self-healing elastomer 1115 that are flush with housing 1150 may improve the blending of the self-healing elastomer with the housing. The improved blending may result in improved aesthetics, making self-healing elastomer 1115 more difficult to discern from housing 1150. This feature may be beneficial when it is desirable to obscure the connector from the user. For example, an electronic device may be so small that it may be undesirable to have an external connector consume a significant portion of the outside surface, marring the aesthetics of the device. In addition,

it may be desirable to deliver an electronic device that is completely wireless, however an external connector may be required for manufacturing and/or diagnostics so methods to obscure the connector from view may at least provide the appearance of a completely wireless device. Further, flush edges 1152 may reduce the likelihood of self-healing elastomer 1115 from being torn or disassociated from housing 1150. Other edge 1152 designs may be employed on self-healing elastomer 1115 such as tapered edges, illustrated in FIG. 12. Flush edge 1152 may be formed during formation of self-healing elastomer 1115, or after formation with a material removal process such as cutting, laser cutting, grinding or the like.

[0063] FIG. 12 illustrates another embodiment of a housing 1150 that may be employed on an electronic device such as device 100 (see FIG. 1), similar to the embodiment described in FIG. 11. This embodiment also includes one or more retention features 1151 formed in opening 1105 that is filled with self-healing elastomer 1115. However, this embodiment has tapered edges 1153 on self-healing elastomer 1115.

[0064] Tapered edges 1153 of self-healing elastomer 1115 may improve the blending of the self-healing elastomer with housing 1150. The improved blending may result in improved aesthetics, making self-healing elastomer 1115 more difficult to discern from housing 1150. As discussed above, this feature may be beneficial when it is desirable to obscure the connector from the user and/or reduce the likelihood of self-healing elastomer 1115 from being torn or disassociated from housing 1150. Other edge 1153 designs may be employed on self-healing elastomer 1115 such as, for example, a radius, a chamfer or a sub-flush edge. A sub-flush edge is where self-healing elastomer 1115 is disposed below an outer surface of housing 1150.

[0065] FIGS. 13A through 13C illustrate various embodiments of electrical probes that may be used to temporarily penetrate the self-healing elastomer to connect with the connector contacts. In some embodiments the electrical probes may be designed to minimize damage to the self-healing elastomer, and/or to make electrical contact with the connector contacts. In further embodiments the probes may be made from an electrically conductive material such as, but not limited to, brass, copper, bronze, steel or nickel. In other embodiments, the electrical probes may have one or more layers of plating such as, but not limited to, nickel, gold, silver, tin or palladium. The plating may be used to decrease contact resistance between the probe and the contact and/or to improve the durability of the probe. Myriad probe designs may be used without departing from the invention. In further embodiments, the electrical probes may not be oriented perpendicular to the contacts (as illustrated in FIGS. 4-6) during penetration and may approach the contacts at an obtuse angle. In other embodiments, the electrical probes may be guided to the electrical contacts by the opening in the housing or another alignment feature on the electronic device. In further embodiments, external fixturing may align the electrical probes with the contacts.

[0066] FIG. 13A illustrates electrical probe 1300 having a shaft 1305 with a shoulder 1310 and a tapered nose portion 1315 terminating in a blunt tip 1320. Blunt tip 1320 may increase the physical contact area with contact 310 (see FIG. 3) and may minimize penetration of probe 1300 into the contact.

[0067] FIG. 13B illustrates an electrical probe 1330 having a shaft 1335 with a tapered nose portion 1345 terminating in

a sharp tip **1350**. Sharp tip **1350** may decrease the damage to self-healing elastomer and may allow probe **1330** to penetrate contact **310** (see FIG. 3) making a more reliable electrical connection.

[0068] FIG. 13C illustrates an electrical probe **1360** having a shaft **1365** with an enlarged shoulder **1370**, a short tapered nose portion **1375** terminating in a sharp tip **1380**. Sharp tip **1380** may allow probe **1360** to penetrate contact **310** (see FIG. 3) making a more reliable electrical connection, and enlarged shoulder **1370** may limit the penetration depth of probe **1360** into contact **310** (see FIG. 3).

[0069] Embodiments of the present invention may include a connector disposed in an electronic device for receiving an audio plug such as plug **145** in FIG. 2. Standard audio plugs, such as those illustrated in FIGS. 14 and 15, are available in three sizes according to the outside diameter of the plug: a 6.35 mm (1/4") plug, a 3.5 mm (1/8") miniature plug and a 2.5 mm (3/32") subminiature plug. Plugs **1410** and **1520** include multiple conductive regions that extend along the length of the connectors in distinct portions of the plug such as the tip, sleeve and one or more middle portions or "rings" located between the tip and sleeve, resulting in the connectors often being referred to as TRS (tip, ring and sleeve) connectors.

[0070] More specifically, FIGS. 14 and 15 illustrate examples of audio plugs **1410** and **1520** having three and four conductive portions, respectively. As shown in FIG. 14, plug **1410** includes a conductive tip **1412**, a conductive sleeve **1416** and a conductive ring **1414** electrically isolated from tip **1412** and sleeve **1416** by insulating rings **1417** and **1418**. The three conductive portions **1412**, **1414**, **1416** are for left and right audio channels and a ground connection, respectively.

[0071] Plug **1520**, shown in FIG. 15, includes four conductive portions: a conductive tip **1522**, a conductive sleeve **1526** and two conductive rings **1524**, **1525** and is thus sometime referred to as a TRRS (tip, ring, ring, sleeve) connector. The four conductive portions **1522**, **1524**, **1525** and **1526** are electrically isolated by insulating rings **1527**, **1528** and **1529** and are typically used for left and right audio, ground and microphone signals, respectively.

[0072] When plugs **1410** and **1520** are 3.5 mm miniature connectors, the outer diameter of conductive sleeve **1416**, **1526** and conductive rings **1414**, **1524**, **1525** is 3.5 mm and the insertion length of the connector is 14 mm. For 2.5 mm subminiature connectors, the outer diameter of the conductive sleeves is 2.5 mm and the insertion length of the connector is 11 mm long. Such TRS and TRRS connectors are used in many commercially available MP3 players and smart phones as well as other electronic devices.

[0073] Plugs **1410** and **1520** may interface with a connector, such as connector **1600** in FIG. 16, mounted in an electronic device such as device **100** in FIG. 2. Because connector **1600** is accessible from the exterior of electronic device **100**, it may be exposed to moisture or debris that pose little or no risk to the consumer, but present a harsh environment for the connector contacts and electronic circuitry within the electronic device. For example, electronic devices and their connectors regularly come into contact with water, sweat, and other elements that may corrode or contaminate the contacts and may penetrate the electronic device, harming circuitry within its housing. Embodiments of the invention may include the use of a self-healing elastomer on such audio connectors to provide improved reliability and/or improved resistance to liquid, moisture and/or gas ingress. However,

these embodiments should in no way limit the applicability of the invention to other connectors.

[0074] FIG. 16 is a simplified exploded perspective view of audio connector **1600**, in accordance with one embodiment of the invention. Connector **1600** may include a body having an opening **1655** that communicates with a cavity **1665** having height, width and depth dimensions. Connector **1600** may have a receiving face **1650** with front opening **1655** to receive a plug portion of a mating audio plug connector **145** (e.g., FIGS. 14 and 15) and rear face **1660** disposed opposite of the receiving face. Housing **1605**, **1610** may extend between receiving face **1650** and rear face **1660** and define a cavity **1665** that communicates with front opening **1655**. A plurality of sequentially arranged contacts **1622a**, **1624a**, **1625a**, **1626a**, may be sequentially positioned within and spaced apart along a depth of the cavity and each may have external portions **1622c**, **1624c**, **1625c**, **1626c** disposed outside of housing **1605**, **1610**. External portions **1622c**, **1624c**, **1625c**, **1626c** may be configured to mount connector **1600** to a printed circuit board or similar structure and provide an electrical path from contacts **1622a**, **1624a**, **1625a**, **1626a** to circuitry within the electronic device. Other types and configurations of audio connectors may be used without departing from the invention.

[0075] FIG. 17 illustrates a cross-sectional view of audio connector **1600** (see FIG. 16) installed within housing **1605** of an electronic device such as device **100** in FIG. 2. Contacts **1622a**, **1624a**, **1625a**, **1626a** are accessible through opening **1610** in housing **1605**. A layer of self-healing elastomer **1615** is disposed over opening **1610** in housing **1605**. Self-healing elastomer **1615** may provide a protective barrier for contacts **1622a**, **1624a**, **1625a**, **1626a** and housing **1605**. More specifically, in some embodiments, self-healing elastomer **1615** may provide moisture and debris protection to contacts **1622a**, **1624a**, **1625a**, **1626a** and housing **1605** such that water and debris may not penetrate the self-healing elastomer. In further embodiments, self-healing elastomer **1615** may provide a barrier against water vapor and in further embodiments may provide a hermetic seal (i.e., impervious to gases). Self-healing elastomer may be bonded to housing **1605** and may have flush or tapered edges as discussed above. In other embodiments, self-healing elastomer **1615** may be filled with one or more pigments to obscure contacts **1622a**, **1624a**, **1625a**, **1626a** and opening **1610** as also discussed above.

[0076] Audio connectors such as those illustrated in FIGS. 14 and 15 may penetrate self-healing elastomer **1615** to make electrical contact with contacts **1622a**, **1624a**, **1625a** and **1626a**. Once the audio connector is removed, self-healing elastomer **1615** may self-heal, regaining at least some of its aesthetic, protective and/or mechanical properties.

[0077] FIG. 18 illustrates another embodiment showing a cross-sectional view of audio connector **1600** (see FIG. 16) installed within housing **1805** of an electronic device such as device **100** in FIG. 2. In this embodiment, a self-healing elastomer **1815** with conductively doped regions **1820** is disposed inside of audio connector **1600**. Contacts **1622a**, **1624a**, **1625a**, **1626a** are accessible through opening **1810** in housing **1805**. A layer of self-healing elastomer **1815** is disposed in a cylindrical shape over the interior of audio connector **1600**. Self-healing elastomer **1815** may provide a protective barrier for contacts **1622a**, **1624a**, **1625a**, **1626a** and housing **1805**. More specifically, in some embodiments, self-healing elastomer **1815** may provide moisture and debris

protection to contacts **1622a**, **1624a**, **1625a**, **1626a** and housing **1805** such that water and debris may not penetrate the self-healing elastomer. In further embodiments, self-healing elastomer **1815** may provide a barrier against water vapor and in further embodiments may provide a hermetic seal (i.e., impervious to gasses). Self-healing elastomer may be bonded to housing **1805** and may have flush or tapered edges as discussed above. In other embodiments, self-healing elastomer **1815** may be filled with one or more pigments to obscure contacts **1622a**, **1624a**, **1625a**, **1626a** and opening **1810** as also discussed above.

[0078] As further illustrated, one or more conductively doped regions **1820** may be disposed over each of contacts **1622a**, **1624a**, **1625a**, **1626a**. Thus, when conductive sleeves **1416**, **1526** and conductive rings **1414**, **1524**, **1525** of audio connectors **1410** and **1520** (see FIGS. **14** and **15**) come into contact with conductively doped regions **1820**, electrical contact is made between the audio connectors and the circuitry within housing **1805**. In some embodiments an additional layer of self-healing elastomer may be placed over opening **1810**.

[0079] In some embodiments self-healing elastomer **1820** may be manufactured as discussed above, and subsequently inserted into cavity **1665** (see FIG. **16**) of connector **1600**. In other embodiments, self-healing elastomer may be molded around contacts **1622a**, **1624a**, **1625a**, **1626a** and installed as an assembly into housing **1605**, **1610** (see FIG. **16**). Other methods may be used to manufacture the embodiment illustrated in FIG. **18** without departing from the invention.

[0080] FIG. **19** illustrates another embodiment showing a cross-sectional view of audio connector **1600** (see FIG. **16**) installed within housing **1905** of an electronic device such as device **100** in FIG. **2**. Similar to the embodiment described in FIG. **18**, a self-healing elastomer **1915** having conductively doped regions **1920** is disposed inside of audio connector **1600**. However, in this embodiment substantially the entire cavity **1665** (see FIG. **16**) of connector **1600** is filled with self-healing elastomer **1915**. Contacts **1622a**, **1624a**, **1625a**, **1626a** are accessible through opening **1910** in housing **1905**. Layers of self-healing elastomer **1915** are disposed in a cylindrical shape in the interior of audio connector **1600**. Layers of conductively doped regions **1920** are also disposed in cylindrical shapes in the interior of audio connector **1600**. Layers of self-healing elastomer **1915** are disposed between layers of conductively doped regions **1920** to provide electrical isolation.

[0081] As further illustrated, one or more conductively doped regions **1920** may be disposed over each of contacts **1622a**, **1624a**, **1625a**, **1626a**. Thus, when conductive sleeves **1416**, **1526** and conductive rings **1414**, **1524**, **1525** of audio connectors **1410** and **1520** (see FIGS. **14** and **15**) come into contact with conductively doped regions **1920**, electrical contact is made between the audio connectors and the circuitry within housing **1905**. In some embodiments an additional layer of self-healing elastomer may be placed over opening **1910**.

[0082] Displacement ports **1925** may be disposed within the audio connector housing to provide for displacement of self-healing elastomer **1910** and conductively doped regions **1920** when an audio connector plug (e.g., FIGS. **14** and **15**) is inserted in audio connector **1600**. Upon removal of audio connector plug, self-healing elastomer **1910** and conductively doped regions **1920** may regain at least some of their aesthetic, protective and/or mechanical properties.

[0083] As discussed above, self-healing elastomer **1910** may provide a protective barrier for contacts **1622a**, **1624a**, **1625a**, **1626a** and housing **1905**. Self-healing elastomer **1910** may be bonded to housing **1905** and may have flush or tapered edges as discussed above. In other embodiments, self-healing elastomer **1910** may be filled with one or more pigments to obscure contacts **1622a**, **1624a**, **1625a**, **1626a** and opening **1910** as also discussed above.

[0084] In some embodiments self-healing elastomer **1920** may be manufactured as discussed above, and subsequently inserted into cavity **1665** (see FIG. **16**) of connector **1600**. In other embodiments, self-healing elastomer **1920** may be molded around contacts **1622a**, **1624a**, **1625a**, **1626a** and installed as an assembly into housing **1605**, **1610** (see FIG. **16**). In further embodiments, layers of self-healing elastomer **1920** may be deposited within cavity **1556** and alternated with layers of conductively doped regions **1920**. Other methods may be used to manufacture the embodiment illustrated in FIG. **19** without departing from the invention.

[0085] FIG. **20** depicts a simplified flowchart **2000** illustrating a general method for interfacing with an electronic device equipped with a hidden connector. The particular series of processing steps depicted in FIG. **20** is not intended to be limiting.

[0086] As depicted in FIG. **20**, the method may be initiated at **2010** when an electronic device equipped with one or more external connectors requires communication, charging or service using a wired connection. The external connector may have a self-healing elastomer disposed over the connector to improve the device aesthetics and/or to protect the connector and the device from damage.

[0087] In some embodiments, such an electronic device may require programming at the manufacturing facility and a wired communication system may be the most tractable method. In other embodiments, such an electronic device may require a wired connection for charging or servicing. More specifically, in some embodiments, an electronic device may be completely wireless (e.g., equipped with wireless communication and charging capabilities) except for a single connector covered by a self-healing elastomer. Thus, in some scenarios the most tractable method to service the device may be through a wired connection, such as, for example, when the internal battery is drained and the wireless communication system is unavailable. In other embodiments an audio system may require a wired connection to the electronic device.

[0088] At **2020**, a data or audio connector may be mated with the external connector on the electronic device. The data or audio connector may have one or more probes, each having a relatively pointed tip to effectively penetrate the self-healing elastomer to make contact with the external connector's electrical contacts. In some embodiments the external connector contacts are metallic pads on a substrate while in other embodiments the external connector contacts may be conductively doped regions within the self-healing elastomer. The data or audio plug may be aligned with the external connector using alignment features in the electronic device and/or external fixtures. The probes within the data or audio connector may pierce the self-healing elastomer in a penetration region, temporarily displacing the self-healing elastomer to make an electrical connection with the external connector contacts.

[0089] At **2030**, the data or audio connectors are mated with the external connector on the electronic device and the power and/or data transfer occurs. Current may flow through the

electronic probes, through the external connector contacts and to the circuitry within the electronic device.

[0090] At **2040**, the data or audio connectors may be demated from the external connector of the electronic device. More specifically, the probes may be removed from the self-healing elastomer and the elastomer may elastically resume its shape prior to the penetration.

[0091] At **2050**, the self-healing elastomer heals in the penetration region. More specifically, self-healing elastomer may reseal itself and regain at least some of its aesthetic, mechanical and/or protective properties. That is, in some embodiments the self-healing elastomer may resume providing an aesthetic covering, a water resistant barrier and/or debris protection for the external connector and the electronic device.

[0092] In further embodiments, the self-healing elastomer may “heal” by reforming chemical bonds, regaining at least some of its mechanical properties in the penetration region. In yet further embodiments, the self-healing elastomer may reform covalent bonds in the penetration region and regain at least 30 percent of its tensile strength in the penetration region. In other embodiments, it may regain at least 50 percent of its tensile strength in the penetration region. In further embodiments it may regain at least 70 percent of its tensile strength in the penetration region. In yet further embodiments it may regain at least 90 percent of its tensile strength in the penetration region. In some embodiments the recovery of tensile strength may occur at approximately 68 degrees centigrade. In other embodiments the recovery of tensile strength may be temperature dependent and may improve with an increase in temperature. In some embodiments the recovery of tensile strength may occur between 60 and 76 degrees centigrade. In other embodiments the recovery of tensile strength may occur between 52 and 84 degrees centigrade. In further embodiments the recovery of tensile strength may occur between 44 and 92 degrees centigrade. In some embodiments the self-healing elastomer may only be penetrated once by the electrical probes, while in further embodiments it may be penetrated numerous times, self-healing after each penetration. In some embodiments the self-healing elastomer may be applied to the device housing, and while in a partially cured condition it may be penetrated by the electrical probes and fully cured after removal of the electrical probes.

[0093] In the foregoing specification, embodiments of the invention have been described with reference to numerous specific details that may vary from implementation to implementation. The specification and drawings are, accordingly, to be regarded in an illustrative rather than a restrictive sense. The sole and exclusive indicator of the scope of the invention, and what is intended by the applicants to be the scope of the invention, is the literal and equivalent scope of the set of claims that issue from this application, in the specific form in which such claims issue, including any subsequent correction.

What is claimed is:

1. An electronic device comprising:

a housing having an opening;

electronic circuitry disposed within the housing;

an electrical connector operatively coupled to the electronic circuitry, the electrical connector comprising a plurality of contacts accessible through the opening in the housing; and

a layer of self-healing elastomer covering the opening and the plurality of contacts.

2. The electronic device of claim **1** wherein a sidewall of the opening has a retention feature formed in it to anchor the self-healing elastomer to the housing.

3. The electronic device of claim **1** wherein there are one or more conductively doped regions within the self-healing elastomer aligned with the plurality of contacts.

4. The electronic device of claim **3** wherein there is one conductively doped region for each contact of the plurality of contacts.

5. The electronic device of claim **1** wherein the self-healing elastomer comprises silicone.

6. The electronic device of claim **1** wherein the self-healing elastomer regains at least 50 percent of its tensile strength in a penetration region after penetration by an electronic probe.

7. The electronic device of claim **1** wherein the self-healing elastomer reforms a water resistant barrier in a penetration region after penetration by an electronic probe.

8. The electronic device of claim **1** wherein the plurality of contacts comprises a power contact, a ground contact and a pair of data contacts.

9. The electronic device of claim **1** wherein the plurality of contacts are disposed on a substrate and are connected by electrical traces to the electronic circuitry.

10. The electronic device of claim **1** further comprising a display operatively coupled to the electronic circuitry.

11. The electronic device of claim **1** wherein the electronic device is a portable media player.

12. The electronic device of claim **1** wherein the electronic device is a wearable device.

13. The electronic device of claim **12** wherein the housing is curved and shaped to be worn on a user's wrist.

14. The electronic device of claim **1** wherein the electrical connector includes a plurality of contacts spaced apart along a depth of the connector.

15. The electronic device of claim **14** wherein conductively doped regions within the self-healing elastomer are disposed over each of the plurality of the contacts.

16. An electronic device comprising:

a housing having an opening;

electronic circuitry disposed within the housing;

an electrical connector operatively coupled to the electronic circuitry, the electrical connector comprising a cavity having a plurality of contacts sequentially positioned within and spaced apart along a depth of the cavity and accessible through the opening in the housing; and

a layer of self-healing elastomer disposed over each of the plurality of contacts.

17. The electronic device of claim **16** wherein the layer of self-healing elastomer disposed over each of the plurality of contacts includes a conductively doped region disposed over each of the plurality of the contacts.

18. The electronic device of claim **16** wherein a layer of self-healing elastomer is disposed over the opening.

19. An electronic device comprising:

a housing having an opening;

a substrate disposed adjacent to the housing, the substrate having one or more electrically conductive contacts arranged to be accessible through the opening; and

a self-healing elastomer disposed over the one or more contacts, the elastomer having a penetration region that is temporarily penetrable by one or more probes, the elastomer capable of reforming chemical bonds in the penetration region after the one or more probes are

removed such that at least 50 percent of the self-healing elastomer's tensile strength is regained in the penetration region.

20. The electronic device of claim **19** wherein there are one or more conductively doped regions within the self-healing elastomer.

* * * * *