

No. 723,808.

PATENTED MAR. 31, 1903.

J. BARDSLEY.
DOOR CLOSER AND CHECK.
APPLICATION FILED MAY 24, 1902.

NO MODEL.

3 SHEETS—SHEET 1.

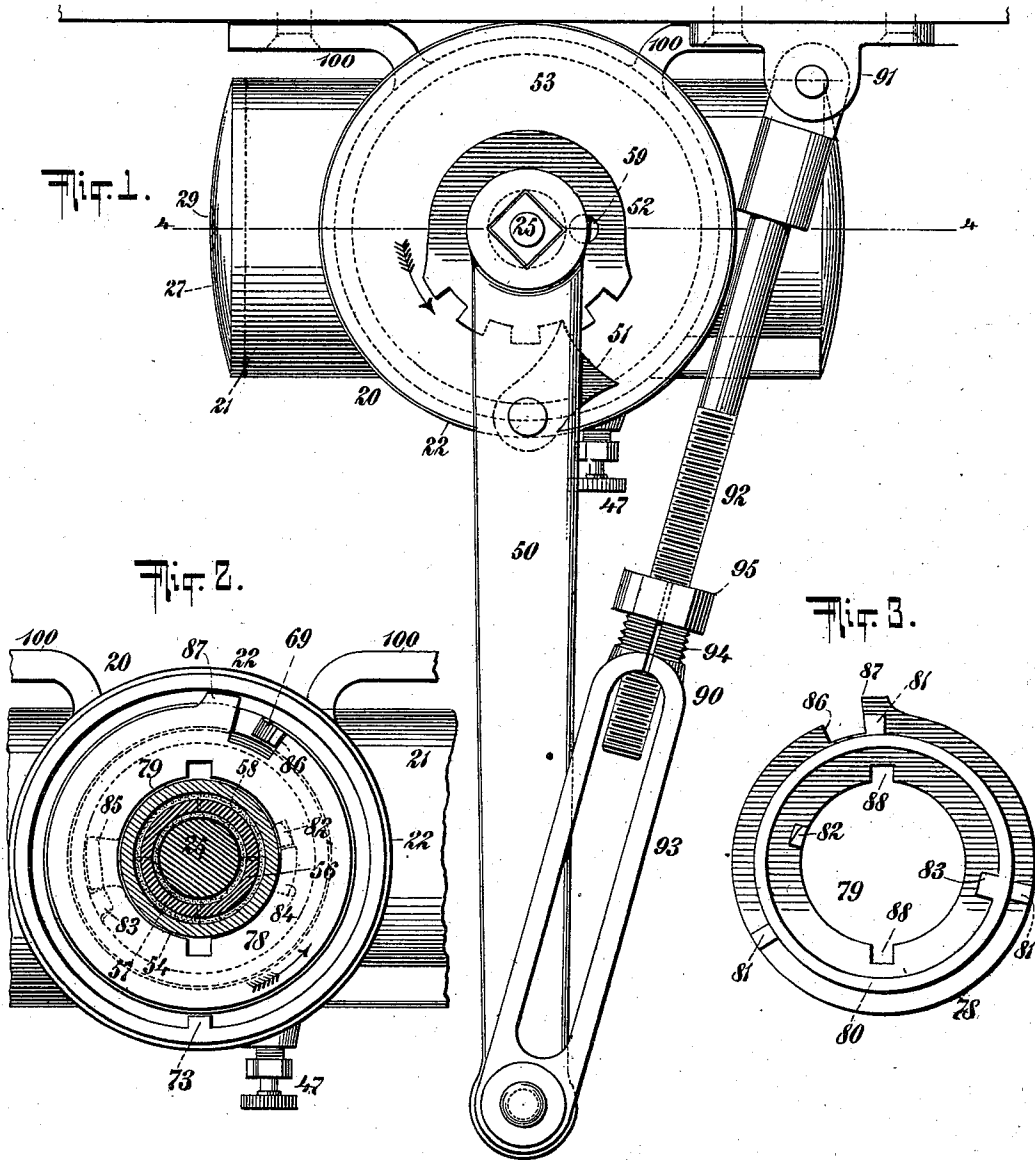

WITNESSES:

Gustav Dietrich
Edwin N. Dietrich

INVENTOR

Joseph Bardsley

BY

Chas. C. Gill
ATTORNEY

J. BARDSLEY.
DOOR CLOSER AND CHECK.
APPLICATION FILED MAY 24, 1902.

NO MODEL.

3 SHEETS—SHEET 2.

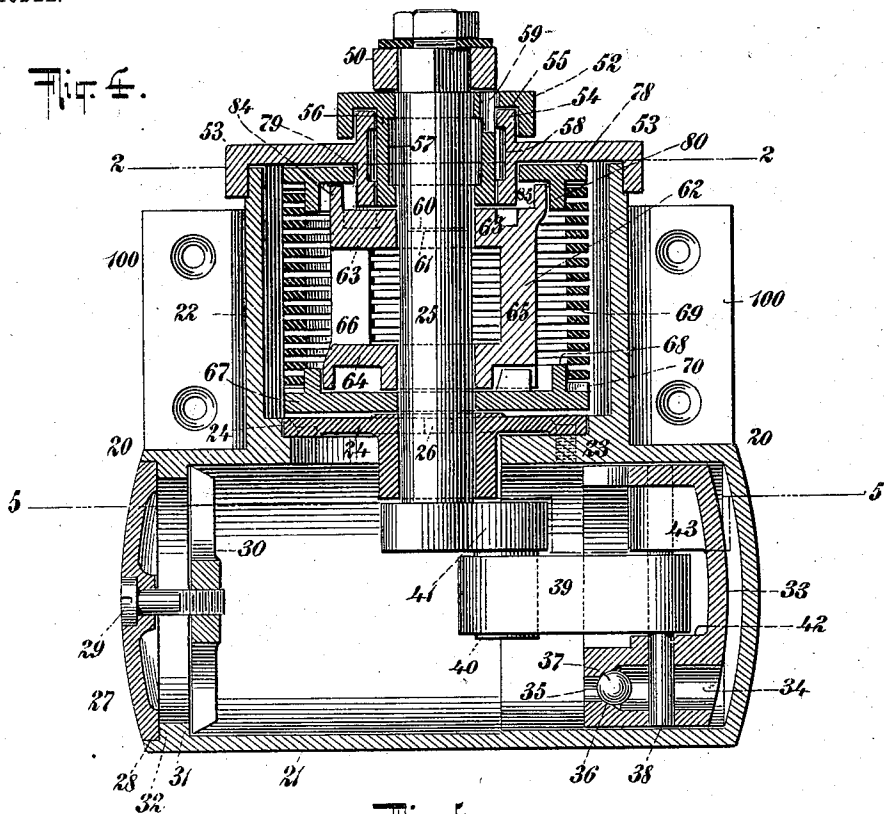
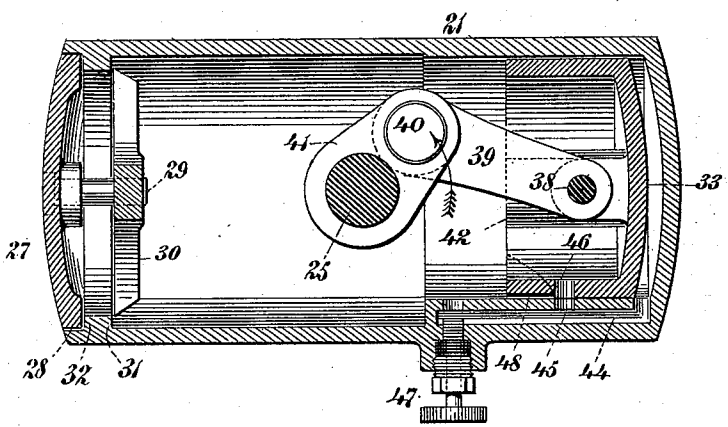

Fig. 5.



WITNESSES:

Gustave Dietsch.

Edwin N. Britnich.

INVENTOR

Joseph Bardsley

BY

Chas. C. Gill
ATTORNEY

J. BARDSLEY.
DOOR CLOSER AND CHECK.
APPLICATION FILED MAY 24, 1902.

NO MODEL.

3 SHEETS—SHEET 3.

Fig. 6.

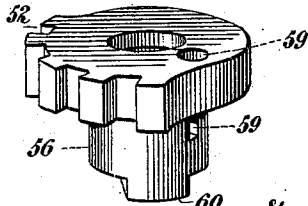

Fig. 12.

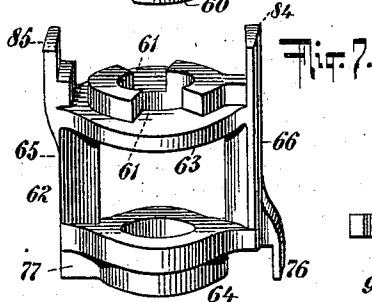
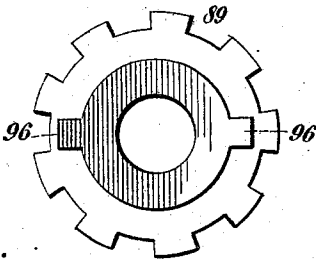

Fig. 13.

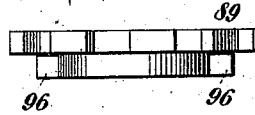

Fig. 10.

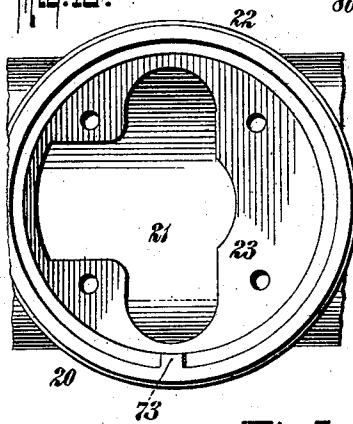

Fig. 8.

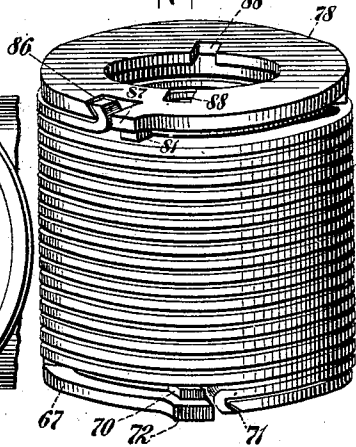

Fig. 11.

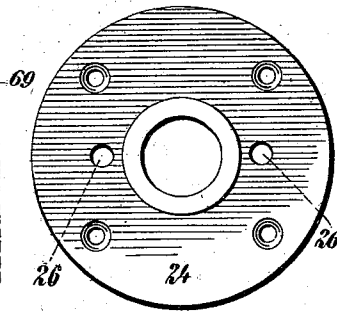
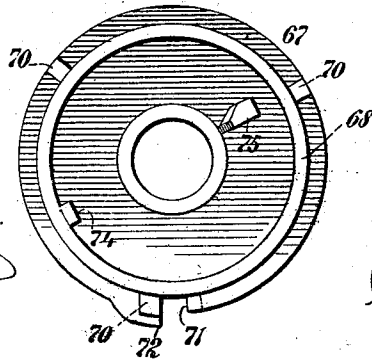

Fig. 9.



WITNESSES:

Gustave Dietrich
Edwin H. Dietrich

INVENTOR

Joseph Bardsley

BY

Chas. C. Gill
ATTORNEY

UNITED STATES PATENT OFFICE.

JOSEPH BARDSLEY, OF MONTCLAIR, NEW JERSEY.

DOOR CLOSER AND CHECK.

SPECIFICATION forming part of Letters Patent No. 723,808, dated March 31, 1903.

Application filed May 24, 1902. Serial No. 108,772. (No model.)

To all whom it may concern:

Be it known that I, JOSEPH BARDSLEY, a citizen of the United States, and a resident of Montclair, in the county of Essex and State of New Jersey, have invented certain new and useful Improvements in Door Closers and Checks, of which the following is a specification.

The invention relates to improvements in door closers and checks; and it consists in the novel features, arrangement, and combinations of parts hereinafter described, and particularly pointed out in the claims.

The object of the invention is to provide an entirely efficient and durable door check and closer adaptable for either right or left hand doors, the closer embracing a double-acting spring, which may be wound from one end during the opening of a right-hand door and from the other end during the opening of a left-hand door.

A further object of the invention is to produce a door check and closer having an inclosing casing embracing a spring-chamber and liquid-cylinder in free communication with each other, but from which the liquid cannot escape during the shipment or handling of the device, the upper end of said casing being rendered liquid-tight by means which will not retard the movement of the parts extending through the same.

In carrying out my invention I provide a structure embracing the usual actuating-spindle and operating lever-arm thereon, with suitable intermediate connections for operating the checking-piston from said spindle and either end of said spring from said lever-arm, said spring and its connecting parts being free of said spindle and not depending for their operation upon said spindle.

The door check and closer of my invention also embraces certain novel details of form, arrangement, and construction, whereby the several features of the apparatus are rendered entirely efficient, durable, and convenient of use.

The invention will be fully understood from the detailed description hereinafter presented, reference being had to the accompanying drawings, in which—

Figure 1 is a top view of a door check and closer constructed in accordance with and

embodying the invention, the several parts being shown in the position they occupy when the door is in its closed position. Fig. 2 is a top view, partly broken away and partly in section, of same, the section being on the dotted line 2 2 of Fig. 4. Fig. 3 is a bottom view of the rotary plate, which engages the upper end of the spring for winding the latter during the opening of the door when the device is applied to right-hand doors. Fig. 4 is a central vertical section of the door check and closer on the dotted line 44 of Fig. 1. Fig. 5 is a horizontal section of same on the dotted line 55 of Fig. 4. Fig. 6 is a detached perspective view of a ratchet-plate and sleeve to be applied upon the upper end of the actuating-spindle, said ratchet-plate to be engaged by a pawl carried by the lever-arms and said sleeve being adapted to engage an intermediate rotary part for rotating plates connected with the ends of the closing-spring whereby to wind said spring from either end. Fig. 7 is a detached perspective view of the intermediate rotary frame mounted upon the actuating-spindle and to be engaged at its upper central portion by the sleeve shown in Fig. 6, while the outer end portions of said frame are to engage the top and bottom plates shown in Figs. 3 and 9 connected with the ends of the closing-spring. Fig. 8 is a detached perspective view of the closing-spring with the top and bottom plates applied thereto. Fig. 9 is a top view of the bottom plate connected with the lower end of the closing-spring. Fig. 10 is a top view, partly broken away and with the closing-cap removed, of the exterior casing of the check and closer, this figure being presented for the purpose of illustrating the partition at the base of the spring-chamber. Fig. 11 is a top view of a bearing-plate which is to be applied upon the actuating-spindle and secured by screws to the partition shown in Fig. 10 at the base of the spring-chamber. Fig. 12 is a detached bottom view of a tool employed for winding the closing-spring preparatory to its inclosure within the spring-chamber, and Fig. 13 is an edge view of same.

In the drawings, 20 designates the exterior casing, comprising the cylinder 21 and spring-chamber 22, said cylinder being disposed below said spring-chamber, as usual, and par-

tially separated therefrom by means of a partition 23, disposed at the base of the spring-chamber and adapted to receive the bearing-plate 24, which has a vertical tubular central portion fitting upon the actuating-spindle 25 and is adapted to be secured by screws to the said partition 23, as shown in Fig. 4. The bearing-plate 24 is formed with apertures 26, which afford a free communication for the liquid between the cylinder 21 and spring-chamber 22. The cylinder 21 is in one integral casting, except at one end, where said cylinder is closed by means of the cap 27, fitting within an annular recess 28, formed in the end of said cylinder and detachably held in place by means of the screw 29 and spider-frame 30, the latter engaging an annular shoulder 31, formed with the cylinder 21 and having a central threaded aperture to receive the inner threaded end of the screw 29. It will be observed that upon the tightening of the screw 29 the head of the latter bearing against the cap 27 will operate to bind said cap very tightly against the shoulder 32, formed at the base of the aforesaid recess 28.

Within the cylinder 21 is placed the piston 33, within which is formed an aperture comprising the sections 34 35, the latter being less in diameter than the section 34 and being at the inner end of the piston. At the junction of the sections 34 35 is formed the valve-seat 36 for the ball-valve 37, which when against said seat will close the passage through the piston, as during the closing of the door, and which is prevented from escaping from the larger section 34 by means of the pin 38, which extends entirely through the piston, as shown in Fig. 4, and serves the twofold purpose of confining the ball-valve 37 and pivotally receiving the outer end of the piston-rod 39, whose inner end receives a pin 40, depending from the crank-arm 41, carried by the lower end of the actuating-spindle 25. The piston 33 is of cup shape and is formed in its interior with the thickened sections 42 43, said section 42 containing the passage through the piston and said sections 42 43 affording substantial bearing-surfaces for the pin 38. The outer end of the piston-rod 39 fits freely, though rather snugly, between the facing sides of the sections 42 43, and hence the pin 38 is capable of withstanding all of the strain to which it may be subjected during the use of the door check and closer. The fact that the pin 38 crosses the larger section 34 of the aperture through the piston enables the employment of the maximum length of piston-rod 39 and the securing of the outer end of said rod as nearly as may be desired to the outer face of the piston 33, and this construction and arrangement is desirable because the long piston-rod is more effective in uniformly moving the piston, and side thrust on the piston is prevented.

The cylinder 21 is provided with the by-pass 44, extending around the piston 33 and connected with a release-port 45 for cooperation

with a port 46, formed in the wall of the piston 33. The cylinder 21 is also provided with the adjusting-screw 47 for controlling the passage of the liquid through the by-pass 44 in a well-known manner. The port 46 in the piston 33 is intended to pass into alinement with the release-port 45 when the door has reached a nearly-closed position, so that there may be sudden release for the liquid from the by-pass 44 through the ports 45 46 at such time as it may be desired that the closing-spring may exert its force to firmly close and latch the door. Adjacent to the inner edge of the port 46 I cut away the surface of the piston 33, as at 48, so that upon the piston 33 reaching the position at which the release of the liquid in the by-pass 44 should be effected the said liquid may flow through the space 48 as well as through the port 46, and more particularly through the space 48 for any reason the port 46 pass outward beyond the release-port 45, the object being to assuredly effect the release of the liquid when the door has reached a nearly-closed position. There may be occasions, due to irregularities in the construction of the apparatus or in the wear or disposition of the parts thereof, when the port 46 would pass partly beyond the release-port 45 at a time when the release from the by-pass ought to take place, and under any such condition the space 48 cut into the surface of the piston 33 will pass into communication with the release-port 45 and afford a convenient outlet for the liquid.

The actuating-spindle 25 extends upward through the spring-chamber 22 and has detachably secured upon its upper polygonal end the lever-arm 50, carrying a pivoted double-pointed pawl 51 for engagement with the ratchet-plate 52, which is exposed over the cap 53, closing the upper end of the spring-chamber 22, and having a central vertical tubular hub portion 54, whose upper end passes within an annular recess 55, formed in the under side of the ratchet-plate 52. The ratchet-plate 52 is formed with a central depending tubular hub portion 56, which is free upon the upper end of the actuating-spindle 25 and passes snugly within without binding against the hub 54 of the cap 53. The inner surfaces of the hub 56 are cut away to form an annular chamber 57, and the inner surfaces of the hub 54 are cut away to form the annular chamber 58, and the entrance to both of the chambers 57 58 is through the aperture 59, formed in the ratchet-plate 52, said aperture 59, as shown in Fig. 4, opening at its lower end into both of the said chambers 57 58. The chambers 57 and 58 will be filled with any suitable soft packing material forced downward through the aperture 59, in order that a liquid-tight joint, when the same is desired, may be formed between the spindle 25 and hub 56 and between the hub 56 and the hub 54. The packing within the chambers 57 58 will also aid in securing a free movement of the hub 56 upon the spin-

dle 25 and within the hub 54 and in avoiding friction between the contacting surfaces of the said parts. The hub 56 extends downward and forms a substantial bearing for the upper end of the actuating-spindle 25, and the lower end of the hub 56 is formed with projecting lugs 60 to engage the recesses 61, formed at the upper part of the intermediate frame 62, which is also free upon the actuating-spindle 25 and comprises the upper and lower plates 63 64, respectively, and connecting side arms 65 66, as illustrated in Fig. 7. The engagement of the lower end of the hub 56 with the intermediate frame 62 is for the purpose of enabling the ratchet-plate 52 to rotate said frame 62 in either direction in accordance with the movement imparted to said ratchet-plate from the lever-arm 50.

Within the lower end of the spring-chamber 22 is placed the bottom plate 67, which has a central opening enabling said plate to pass downward upon the actuating-spindle 25 and turn freely around the same. The plate 67 is formed with the vertical hub 68 adapted to pass within the lower end of the closing-spring 69, and exterior to said hub 68, the said plate 67 is formed with a series of lugs 70, upon which the lower end of the spring 69 rests and which vary in height corresponding with the inclination of the lower coil of said spring, so as to afford a substantially uniform bearing for the lower end of said spring. The bottom plate 67 is also formed with a lip 71 and laterally-projecting arm 72, as shown in Figs. 8 and 9, the said lip 71 serving to receive the lower hooked end of the spring 69, and the arm 72 being adapted to engage the vertical rib 73, formed on the inner wall of the spring-chamber 22, said arm 72 and said rib 73 cooperating to form a stop for preventing the plate 67 from rotating in one direction beyond a given extent. The plate 67 is also formed with the upwardly-extending lugs 74 75, these lugs being adapted to be respectively engaged by the lugs 76 77, formed at the lower end of the intermediate frame 62, so that the motion of said frame 62 when turned in one direction or toward the left (looking at Figs. 7, 8, and 9) will result in the lugs 76 77 pressing against the lugs 74 75 and compelling the plate 67 to turn with said frame 62 and wind the spring 69 from the lower end of the latter.

Within the upper end of the spring-chamber 22 and resting upon the upper end of the spring 69 is the top plate 78, which has a central opening 79 snugly receiving the downwardly-projecting portion of the hub 54 of the cap 53, as shown in Figs. 2 and 4. The top plate 78 is formed with the depending hub 80 to enter the upper end of the spring 69 and with the series of lugs 81 to bear upon the upper coil of the spring 69, said lugs 81 corresponding substantially with the lugs 70, formed on the bottom plate 67. The top plate 78 is also formed with the depending lugs 82 83, to be engaged, respec-

tively, by the upwardly-projecting lugs 84 85, formed on the upper end of the intermediate frame 62, the purpose of the engagement of the said lugs 84 85 of the frame 62 with the lugs 82 83 of the top plate 78 being to communicate the rotary motion of said frame 62 when said frame 62 is moved in one direction to the top plate 78, whereby to wind the spring 69 from its upper end. The top plate 78 is formed with a lip 86 and arm 87, corresponding with but arranged reversely to the lip 71 and arm 72 of the bottom plate 67, the said lip 86 being provided to receive the upper hooked end of the spring 69 and the arm 87 being for contact with the vertical rib 73, above referred to, said arm 87 contacting with one edge of said rib 73 and the arm 72 contacting with the opposite edge of said rib. The contact of the arm 87 with the rib 73 is to limit the rotation in one direction of the top plate 78. The top plate 78 is also formed with the key-slots 88, which perform no function in the usual operation of the door-closer, but which are utilized in connection with the key 89 (shown in Figs. 12 and 13) for winding the spring 69, so that said spring may be placed under an initial tension, as hereinafter explained.

The spring 69 will preferably consist of a flat wire coil, although I do not limit the invention to the use of flat wire for the spring 69, since springs coiled from flat wire and round wire have been equally well known for very many years.

In the disposition of the intermediate frame 62 upon the actuating-spindle 25 the lugs 76 77 at the lower end of said frame will be arranged at reverse sides of the lugs 74 75 on the bottom plate 67 with the lug 76 against that side of the lug 74 nearer to the stop-arm 72, so that upon the rotation toward the left (looking at Figs. 7, 8, and 9) of said frame 62 the said lugs 76 77 may be enabled to turn the bottom plate 67 toward the left or in a direction carrying its stop-arm 72 from the rib 73, this motion of the plate 67 serving through the lip 71 to wind the spring 69 from its lower end. The lugs 84 85 at the upper end of the frame 62 will also be arranged at opposite sides of the lugs 82 83 of the top plate 78, but reversely to the relation of the lower lugs 76 77 with the lugs 74 75 of the bottom plate 67, so that upon the rotation of the frame 62 to turn the lower plate 67 the upper lugs 84 85 will recede from said lugs 82 83 of said top plate and so that upon the rotation of the said top plate by the engagement of the lugs 84 85 with said lugs 82 83 the top plate may turn and wind the spring 69 from its upper end, the lower lugs 76 77 at such time receding from the lugs 74 75 of the lower plate 67, the latter being thus allowed to remain at rest with its arm 72 pressing against the rib 73. When the parts of the door check and closer are arranged for a right-hand door, as shown in Fig. 1, the rotation of the frame 62 from the lever 50 and ratchet-plate 52 will wind the spring

69 from its upper end, said frame 62 then engaging the lugs of the top plate 78, and when the lever-arms and pawl 51 are arranged for a left-hand door the rotation of the frame 62 from the said ratchet-plate 52 will impart rotary motion to the lower plate 67 and wind the spring 69 from its lower end.

I desire to direct special attention to the fact that all of the parts inclosed within the spring-chamber, including the spring, are free of and in no manner connected to the actuating-spindle 25, said spindle being employed mainly for imparting motion from the lever-arm 50 to the piston 33. The spring 69 may, as above explained, be wound from either its upper end or lower end, and under either condition the winding of the spring will be effected solely from the lever-arm 50, acting through the pawl 51 and ratchet-plate 52, the latter, as hereinbefore explained, being keyed to the intermediate frame 62, whose motion results in winding the spring.

The lever-arm 50 is of usual character and is pivotally connected at its outer end with the adjustable connecting-rod 90, having at one end the usual bracket 91, adapted to be secured to the lintel over the door. The rod 90 is comprised of the threaded section 92 and split section 93, whose end adjoining the said section 92 is in the form of a split sleeve 94, threaded on its interior to engage the thread of the section 92 and threaded on its exterior to receive the clamping-nut 95. The sleeve 94 on its exterior is slightly tapered, and the members of the section 93 have a tendency at the sleeve 94 to spring outward from each other. When the nut 95 is unscrewed from the sleeve 94, the said sleeve will open sufficiently to allow of a free sliding movement of the section 92 within it for the purpose of adjusting the length of the rod 90, and when the nut 95 is returned upon the sleeve 94 it will draw the members of said sleeve toward each other and snugly clamp the same against the threaded section 92, so as to prevent endwise motion of the latter. It will thus be seen that the rod 90 of the construction described may be very readily and conveniently adjusted as to its length, and said lever-arm constitutes a feature of the present invention.

The operation of the door check and closer will be fully understood from the description presented hereinbefore. It may be mentioned, however, that the spring 69 is always under an initial tension, and the manner of applying this initial tension to the spring 69 may be explained. This tension is applied to the spring 69 after the spring has been inserted within the spring-chamber 22, but before the cap 53 has been placed over the spring. Upon the first insertion of the lower plate 67, spring 69, and upper plate 78 the upper end of the spring will extend above the upper edges of the spring-chamber 22, and at such time I apply the tool 89 (shown in Figs. 12 and 13) to the top plate 78, the lugs 96 of said tool entering the

recesses 88 of said top plate and the hole in the center of said tool 89 passing over the upper end of the spindle 25. The tool 89 is recessed along its edges, and when it has been inserted to engage the top plate 78 the said tool 89 may by means of an ordinary spanner be turned to rotate the plate 78 and, through the latter, wind the spring 69, so as to create therein the initial tension desired, the plate 78 at such time being permitted to be turned as much as requisite, because of its arm 87 being above the upper edge of the spring-chamber 22, and consequently free of the rib 73. After the spring 69 has been wound by the tool 89 as much as desired downward pressure will be supplied upon the upper end of said tool and said spring and top plate 78 be pressed downward thereby into the spring-chamber 22, the unwinding of the spring after the same has been pressed downward into the chamber 22 being prevented by the fact that the stop-arm 87 on the top plate 78 will be engaged by the rib 73. After the spring and top plate 78 have been pressed downward into the spring-chamber 22 and said top plate secured by the contact of the arm 87 with the rib 73 the tool 89 will be withdrawn upward over the spindle 25, and thereupon the cap 53 and ratchet-plate 52 will be applied, after which the lever-arm 50 will be secured upon the upper end of the spindle 25. The packing material for the chambers 57 58 may be forced into said chambers at any convenient time.

The means shown for securing the end cap 27 at the end of the cylinder or liquid-chamber 21 are of importance, because they not only enable said cap to be firmly and conveniently secured, but permit of the employment of a cap 27, having plain surfaces corresponding with the surfaces at the opposite end of said cylinder, the ends of said cylinder thus corresponding with each other and neither end having any unnecessary features for enabling it to correspond with the other. The means shown for securing the cap 27 also avoid any threading of the cap or cylinder, the only screw-threads employed being those on the screw 29 and in the spider-frame 30.

The spring and liquid chambers freely communicate with each other, and the liquid will be poured into the spring-chamber until the same fills the liquid-chamber and partly fills the spring-chamber, thus assuring the proper operation of the piston and the constant lubrication of the operative parts within the spring-chamber. The liquid will be introduced into the spring and liquid chambers before the cap 53 is applied to position, and the liquid will then be sealed within the device by the application of said cap and the introduction of the packing material to the annular recesses or chambers 57 58. No difficulty will be experienced in rendering liquid-tight the joint between the outer edges of the spring-chamber and the cap 53, and my present invention removes the great difficulty which has heretofore existed in

sealing the joint between the walls of the central opening in said cap and the working parts extending through the same, since in accordance therewith I provide means for sealing said joint or joints in a simple and inexpensive manner, and which will not result in any material frictional or binding action against said working parts. The packing material for the chambers 57 58 will be introduced through the aperture 59 from the exterior of the device, and this material will be of a semiplastic character and capable of becoming firm within the chambers 57 58 without unduly hardening therein or creating friction. The packing material for the chambers 57 58 should also be of such nature as not to dissolve under the action of the oil or checking liquid. In practice this packing material firmly fills the chambers 57 58 and tends to lessen rather than create friction.

It is of advantage to be enabled to seal the upper end of the spring-chamber, since under such condition the checking liquid may be introduced into the device before the same is shipped and all danger of leakage during shipment or the handling of the device is avoided. The sealing of the spring-chamber is in the present instance especially desirable, since the double-acting spring and its coöperative parts, arranged as described, render it entirely unnecessary for the user of the device to remove the cap 53 in applying the same to right or left hand doors.

What I claim as my invention, and desire to secure by Letters Patent, is—

1. In a door-closer, the operating lever-arm, and the spindle to which said lever-arm is connected, combined with a double-acting coiled-wire spring encompassing but free of said spindle, and means intermediate said lever-arm and the upper and lower ends of said spring and free of said spindle for winding said spring at its respective ends from said lever-arm in accordance with its direction of motion; substantially as set forth.

2. In a door-closer, the operating lever-arm, the actuating-spindle to which said lever-arm is secured, the double-acting coiled-wire spring encompassing but free of said spindle, and means intermediate said lever-arm and the upper and lower ends of said spring and free of said spindle for winding said spring at its respective ends from said lever-arm in accordance with its direction of motion, combined with the cylinder, the checking-piston therein and means connecting said spindle and piston for operating the latter from said spindle; substantially as set forth.

3. In a door-closer, the operating lever-arm, and the spindle to which said lever-arm is connected, combined with a double-acting spring encompassing but free of said spindle, the rotary top plate connected with the upper end of said spring, the rotary bottom plate connected with the lower end of said spring, the intermediate rotary frame adapted to engage and turn the said bottom plate when rotated

in one direction and to engage and turn said top plate when rotated in the reverse direction, and a locking device connected with said lever-arm and extending into engagement with said intermediate frame for rotating the same in either direction in accordance with the direction of motion of said lever-arm, said plates, spring, frame and locking device being free of said spindle; substantially as set forth.

4. In a door-closer, the operating lever-arm, and the spindle to which said lever-arm is connected, combined with the double-acting spring encompassing but free of said spindle, a rotary frame free of said spindle and adapted to effect when rotated in one direction the winding of said spring from its upper end and when rotated in the reverse direction the winding of said spring from its lower end, and means connecting said frame with said lever-arm for rotating said frame in accordance with the direction of motion of said lever-arm; substantially as set forth.

5. In a door-closer, the main lever-arm, and the spindle to which said lever-arm is connected, combined with the double-acting spring encompassing but free of said spindle, the plate 52 mounted loosely upon the upper end of said spindle and having a downwardly-extending key, means for detachably connecting said plate with said lever-arm so that the latter may rotate said plate in either direction, a rotary frame also loosely mounted upon said spindle and engaged by said key for enabling said plate to rotate said frame in either direction, means connected with the opposite ends of said spring and adapted to be alternately engaged by the said frame for enabling said frame when rotated in one direction to wind said spring from one end and when rotated in the reverse direction to wind said spring from its other end, and a stop for holding one end of said spring while the other end thereof is in action; substantially as set forth.

6. In a door-check, the liquid-cylinder having the by-pass and release-port for the liquid, combined with the actuating-spindle, and the piston connected with said spindle, the said piston being adapted when the door is reaching its closed position to uncover the said release-port and allow a sudden escape of the liquid through the same from said by-pass into the said cylinder in rear of said piston; substantially as set forth.

7. In a door-closer, the operating lever-arm, and the spindle to which said lever-arm is connected, combined with the double-acting spring encompassing but free of said spindle, a rotary frame free of said spindle and adapted to effect when rotated in one direction the winding of said spring from its upper end and when rotated in the reverse direction the winding of said spring from its lower end, means connecting said frame with said lever-arm for rotating said frame in accordance with the direction of motion of said lever-arm, the cylinder for liquid, the piston in said cyl-

inder, and means connecting said piston with said spindle for enabling said spindle to operate the same; substantially as set forth.

8. In a door-closer, the exterior casing forming a spring-chamber, the spindle extending through said chamber, the main lever-arm connected to said spindle, and the cap for closing said chamber, said cap having at its center the tubular hub 54 containing the annular recess 58, combined with the spring within said chamber, the plate 52 exposed above said cap and having the hub 56 receiving and free upon said spindle and also having the recess 57 and aperture 59, the latter leading to said recesses 57, 58, a rotary frame freely mounted upon said spindle and engaged by the hub 56 for winding said spring in accordance with the direction of rotation of said plate 52, means connecting said plate and said lever-arm, the cylinder for containing liquid, the piston in said cylinder, and means connecting said piston with the lower end of said spindle for enabling said spindle to operate said piston; substantially as set forth.

9. In a door-closer, the main lever-arm, and the spindle to which said lever-arm is connected, combined with the double-acting spring encompassing but free of said spindle, the inclosing casing having the vertical rib 73, the rotary top plate connected with the upper end of said spring and having the stop-arm 87 for engaging said rib and also the downwardly-extending lugs 82, 83, the rotary bottom plate connected with the lower edge of said spring and having the stop-arm 72 for engaging said rib 73 and also the upwardly-extending lugs 74, 75, the intermediate rotary frame freely mounted on said spindle and having the lugs 76, 77, at its lower end to engage said lugs 74, 75, of the bottom plate and also having the lugs 84, 85 at its upper end to engage said lugs 82, 83 of said top plate, and a tubular locking device freely mounted upon said spindle and connected with said lever-arm and extending into engagement with said intermediate frame for rotating the same in either direction in accordance with the direction of motion of said lever-arm, whereby to wind said spring from either end from said lever-arm; substantially as set forth.

10. In a door-closer, the main lever-arm, and the spindle to which said lever-arm is connected, combined with the double-acting spring encompassing but free of said spindle, the inclosing casing having the vertical rib 73, the rotary top plate connected with the upper end of said spring and having the stop-arm 87 for engaging said rib and also the downwardly-extending lugs 82, 83, the rotary bottom plate connected with the lower edge of said spring and having the stop-arm 72 for engaging said rib 73 and also the upwardly-extending lugs 74, 75, the intermediate rotary frame freely mounted on said spindle and having the lugs 76, 77, at its lower end to

engage said lugs 74, 75, of the bottom plate and also having the lugs 84, 85 at its upper end to engage said lugs 82, 83 of said top plate, the plate 52 freely mounted on said spindle and having its hub portion extending downward into engagement with said intermediate frame for rotating said frame in either direction, and means detachably connecting said plate 52 with said lever-arm for enabling the latter to rotate said plate in either direction, whereby to wind said spring from either end; substantially as set forth.

11. In a door-closer, the spring-chamber, spring, actuating-spindle, and main lever-arm 50 connected with said spindle, combined with the rod 90 pivotally secured at one end to said lever-arm 50 and at its other end carrying the securing-bracket 91, said arm 90 comprising the threaded section 92, split section 93 and nut 95, and said section 93 having the sleeve 94 tapered on its outer surface, threaded on its inner surface to receive said section 92, and threaded on its outer surface to receive said nut 95, and said sleeve having a normal tendency to spring outward from said section 92; substantially as set forth.

12. In a door check and closer, the exterior casing forming the spring-chamber and liquid-chamber, a double-acting spring within said spring-chamber, the actuating-spindle, and the lever-arm, combined with the piston in said cylinder, means connecting said piston with said spindle, the cap 27 set into a recess in the end of said cylinder and engaging an inner shoulder 32 within said cylinder, the frame 30 engaging a shoulder 31 within said cylinder, and the screw 29 passing through said cap and engaging a threaded aperture in said frame 30; substantially as set forth.

13. In a door-check, the liquid-cylinder, and the actuating-spindle, combined with the piston in said cylinder and having the passage through it at one side of its center and comprising the sections 34, 35, and valve-seat 36, the ball-valve 37 in said passage-section 34, the pin 38 extending through the diameter of said piston and crossing said passage-section 34 to confine said ball-valve 37, the crank-arm having the pin 40, carried at the lower end of said spindle, and the connecting-rod 39 pivotally mounted at one end upon said pin 40 and at the other end upon said pin 38, said pin 38 thus serving the twofold purpose of confining said ball-valve 37 and receiving the outer end of said rod 39; substantially as set forth.

14. In a door-closer, the operating lever-arm and the spindle to which said lever-arm is connected, combined with the double-acting spring encompassing said spindle, the inclosing casing forming the spring-chamber, means for restraining the lower end of said spring, the plate 78 connected with the upper end of said spring and having the stop-arm 87, a stop 73 on the inner wall of said casing to be engaged by said stop-arm 87, and means independent of said spindle for connecting

said plate 78 with said lever-arm for enabling said arm to wind said spring, said plate 78 being, also, recessed, as at 88, for permitting the placing of said spring under tension by means of a suitable tool, as shown, prior to the inclosing of the upper end of said spring within said casing; substantially as set forth.

15. In a door check and closer, the exterior casing forming the spring-chamber and liquid-cylinder, the spindle extending through said chamber, the main lever-arm connected to said spindle, and the cap for the upper end of said chamber, said cap having the tubular hub 54 containing the annular recess 58 adapted to contain a packing material, combined with a closing-spring within said chamber, the plate 52 exposed above said cap and having the hub 56 for effecting the winding of said spring and containing the annular recess 57 adapted to contain a packing material, means for permitting the introduction of a sealing frictionless packing material from

without the apparatus to said recesses, and the piston connected with said spindle; substantially as set forth.

16. In a door check and closer, the exterior casing forming the spring-chamber and liquid-cylinder, the spindle, lever-arm, piston, closing-spring, and cap for said chamber, combined with a tubular hub receiving said spindle at the center of said cap and containing the annular recess surrounding said spindle, and means for permitting the introduction from without the device of a sealing frictionless packing material to said recess to become firm therein and prevent leakage around said spindle; substantially as set forth.

Signed at New York, in the county of New York and State of New York, this 23d day of May, A. D. 1902.

JOSEPH BARDSLEY.

Witnesses:

CHAS. C. GILL,
ARTHUR MARION.