



(19) **United States**

(12) **Patent Application Publication** (10) **Pub. No.: US 2017/0346308 A1**

Kain et al.

(43) **Pub. Date: Nov. 30, 2017**

(54) **POWER BALANCING COMMUNICATION FOR BATTERY MANAGEMENT**

(52) **U.S. Cl.**
CPC *H02J 7/0014* (2013.01); *H04L 12/42* (2013.01); *H02J 7/0021* (2013.01); *H02J 2007/0096* (2013.01)

(71) Applicant: **Infineon Technologies AG**, Neubiberg (DE)

(57) **ABSTRACT**

(72) Inventors: **Clemens Kain**, Kammern (AT); **Guenter Hofer**, St. Oswald (AT); **Jesus Ruiz Sevillano**, Zorneding (DE)

A battery management system is described that includes a controller configured to control electrical charging and discharging of a plurality of blocks of a battery. The battery management system also includes an inter-block communication network including a master node and a plurality of slave nodes arranged in a ring-type daisy-chain configuration with the master node. The master node is coupled to the controller and configured to initiate all command messages sent through the inter-block communication network and terminate all reply messages sent through the inter-block communication network. The plurality of slave nodes is bounded by an initial node coupled to the master node and a last node coupled to the master node.

(21) Appl. No.: **15/169,475**

(22) Filed: **May 31, 2016**

Publication Classification

(51) **Int. Cl.**
H02J 7/00 (2006.01)
H04L 12/42 (2006.01)

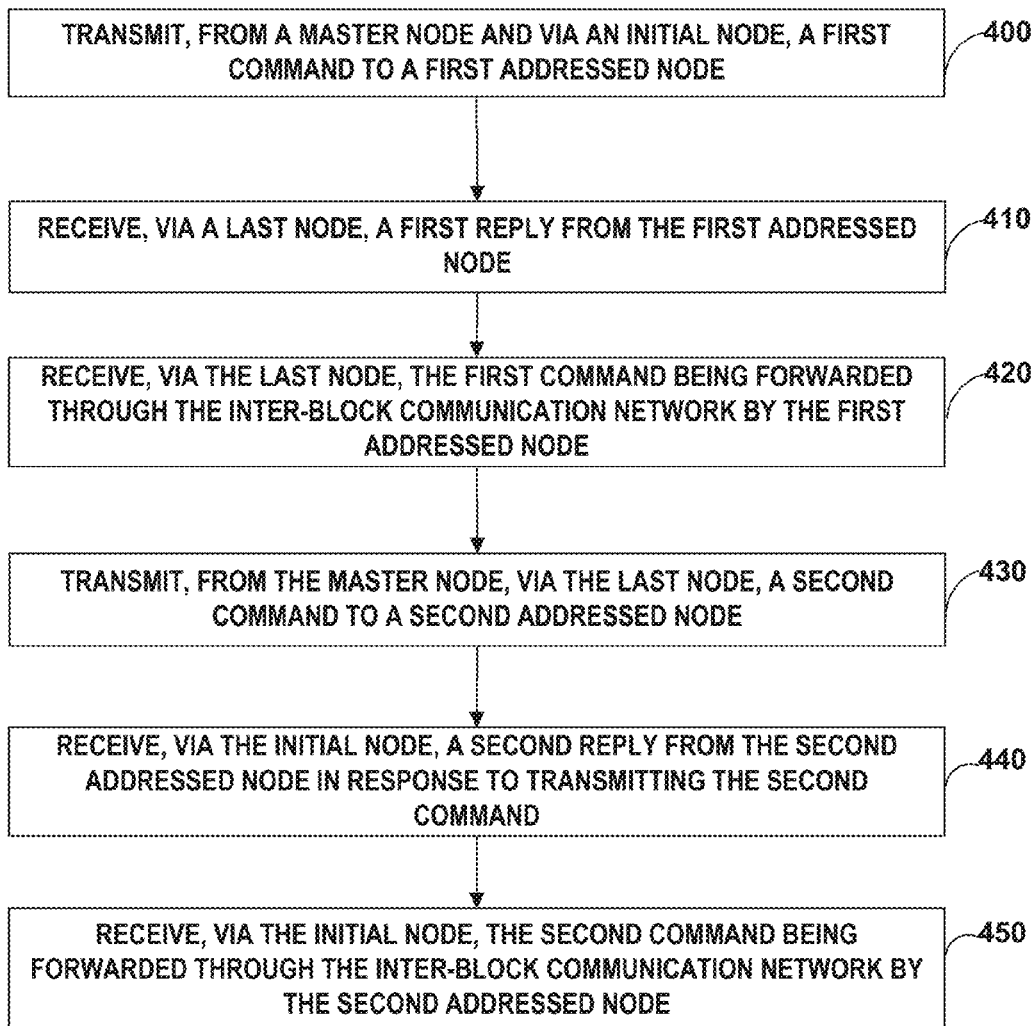

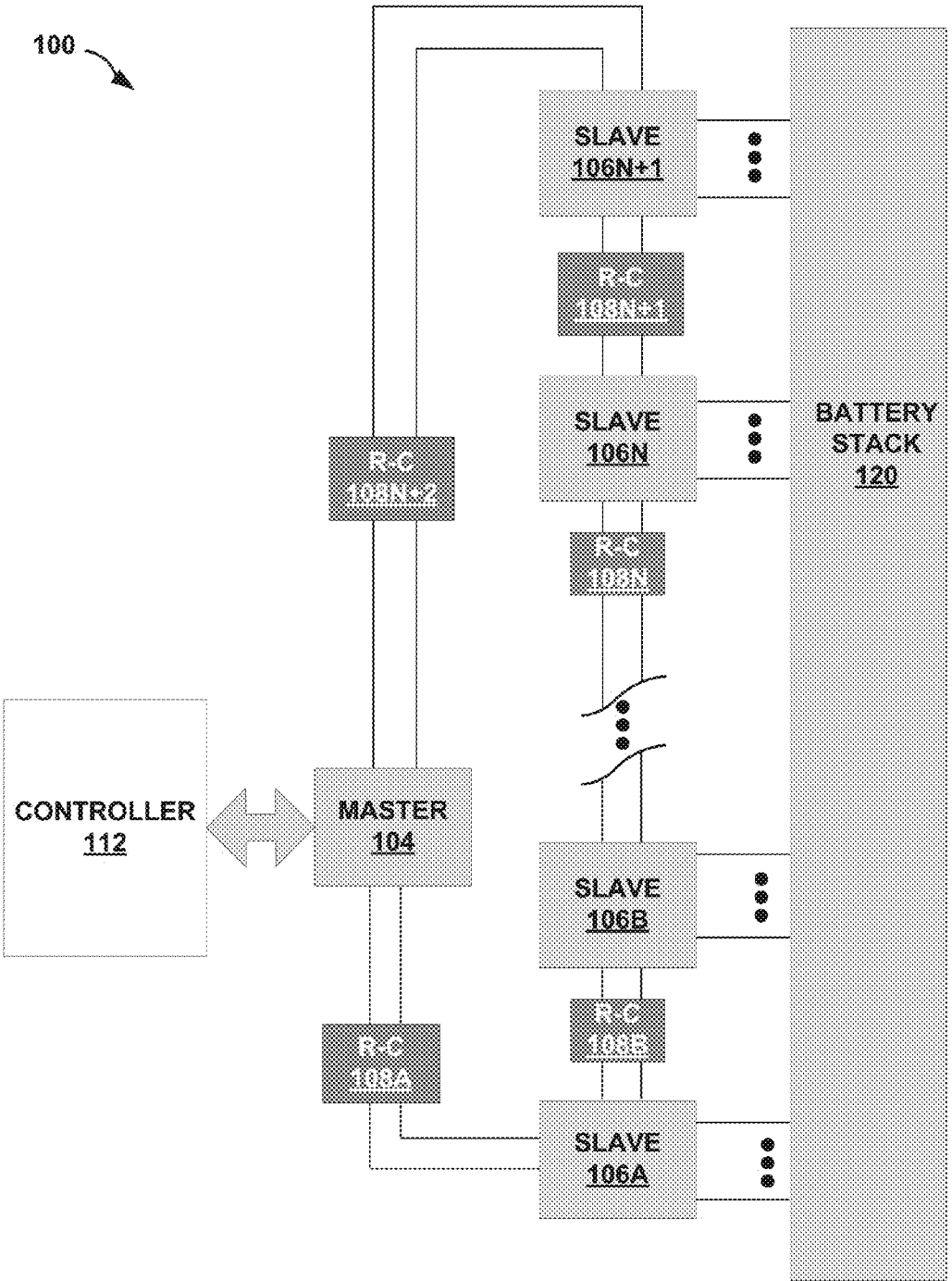

FIG. 1

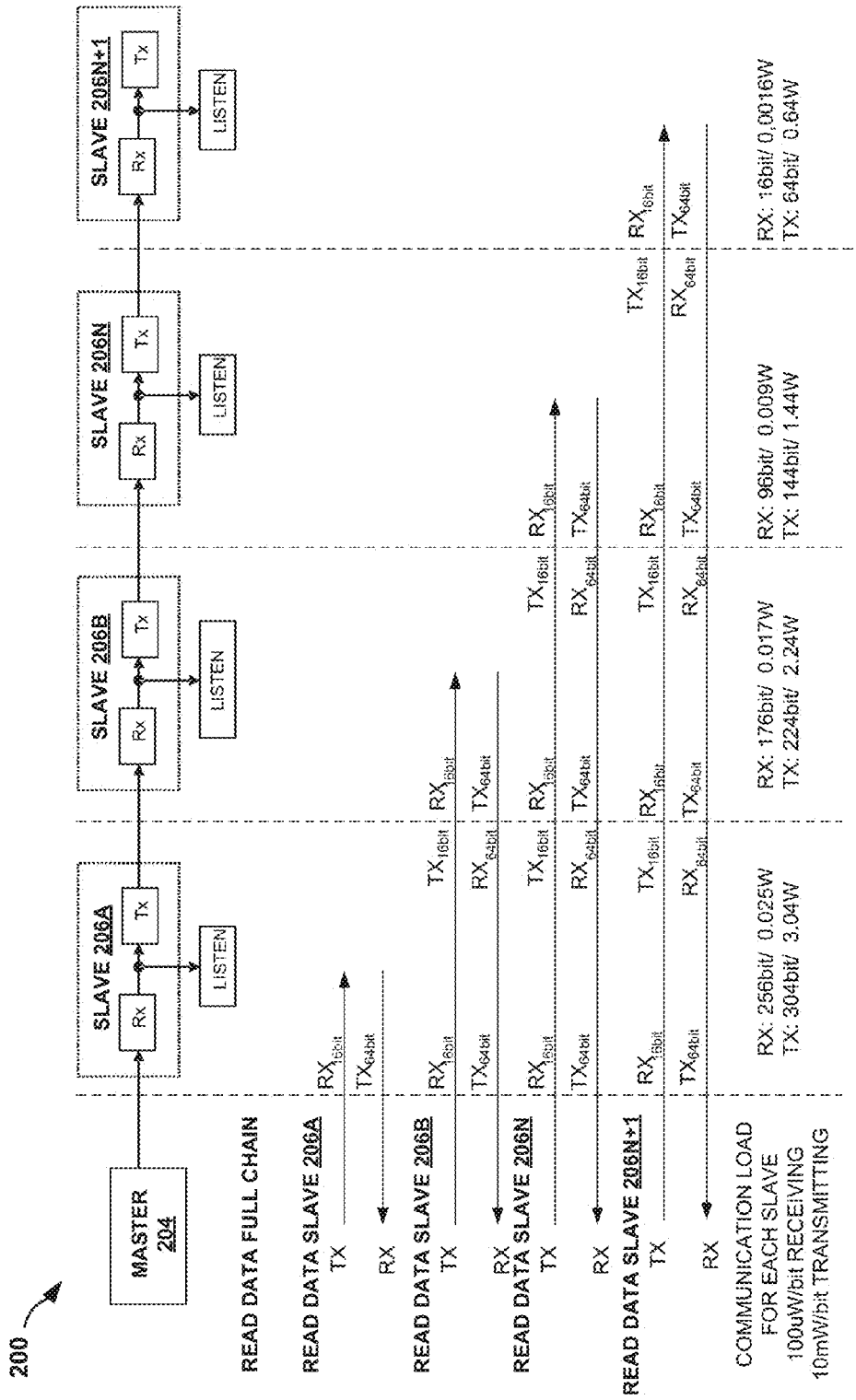

FIG. 2

300 →

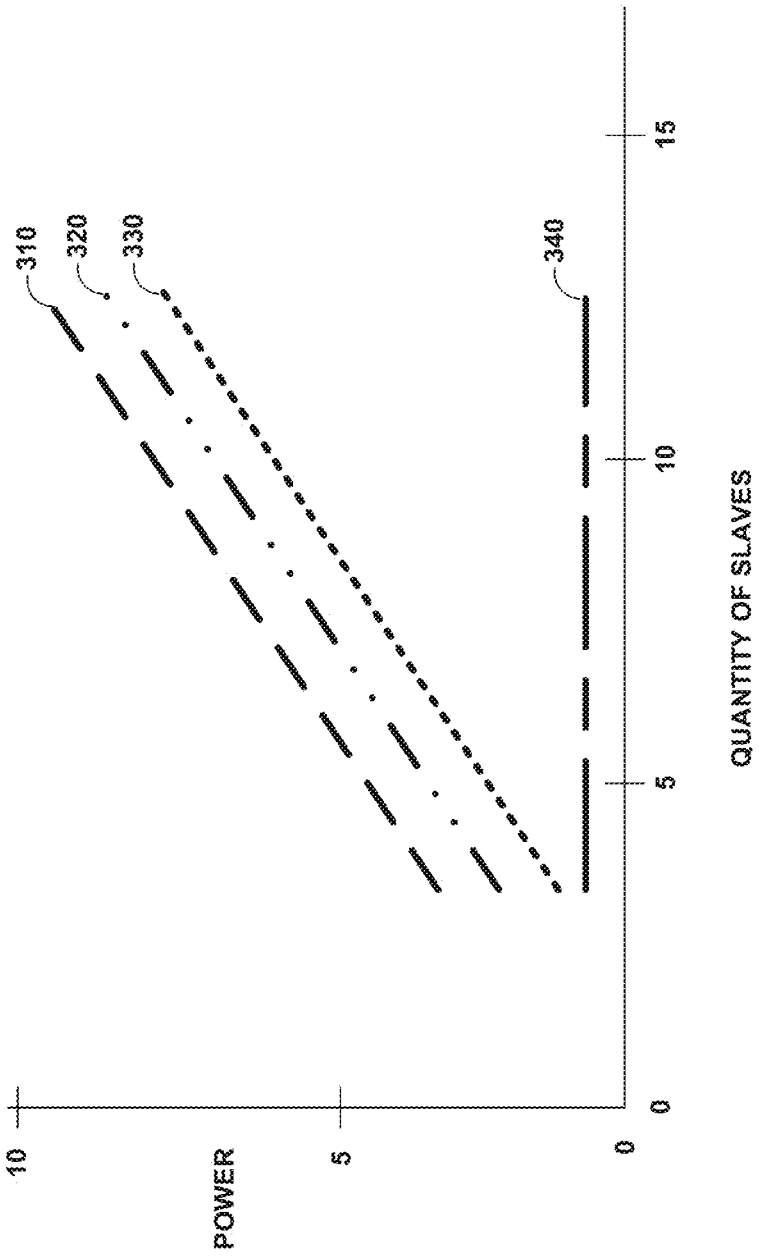

FIG. 3

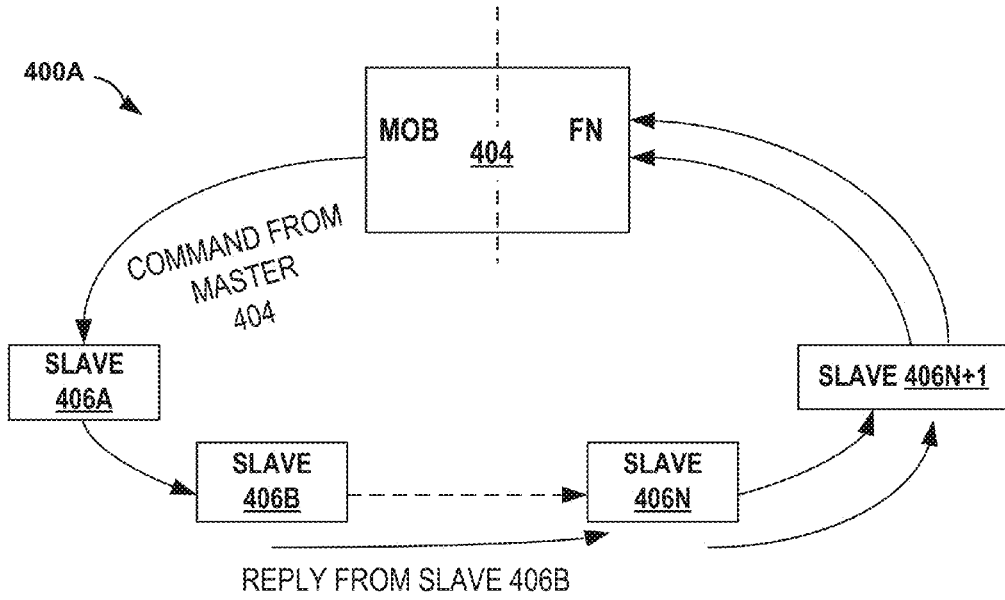

FIG. 4A

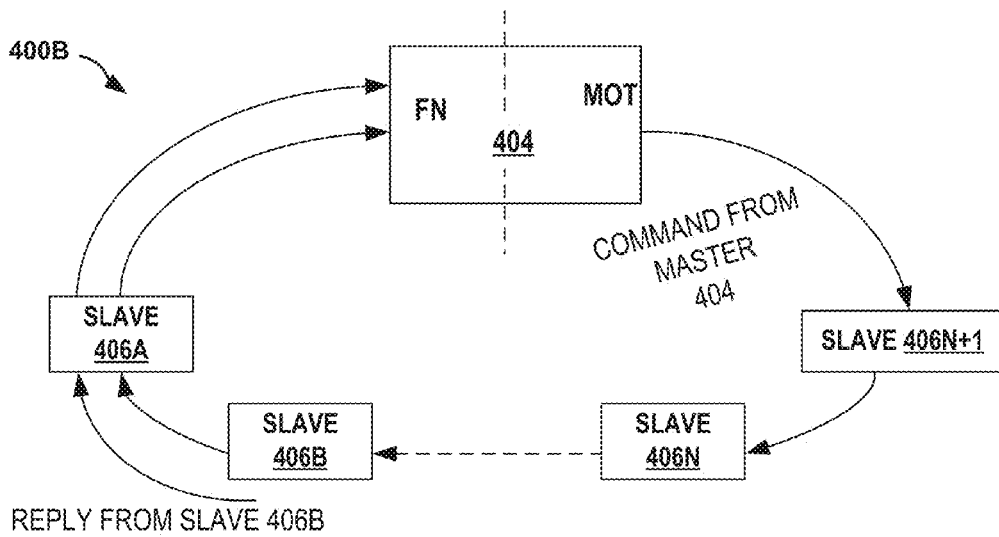

FIG. 4B

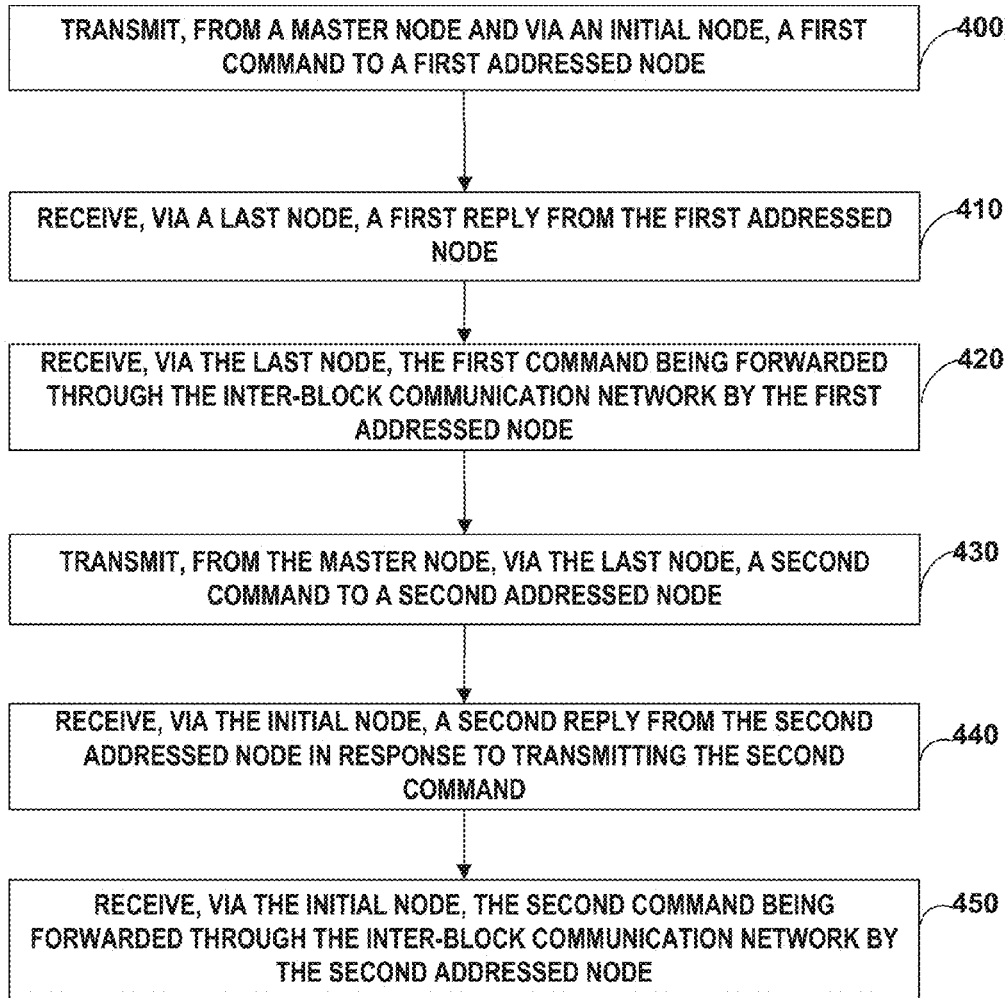

FIG. 4C

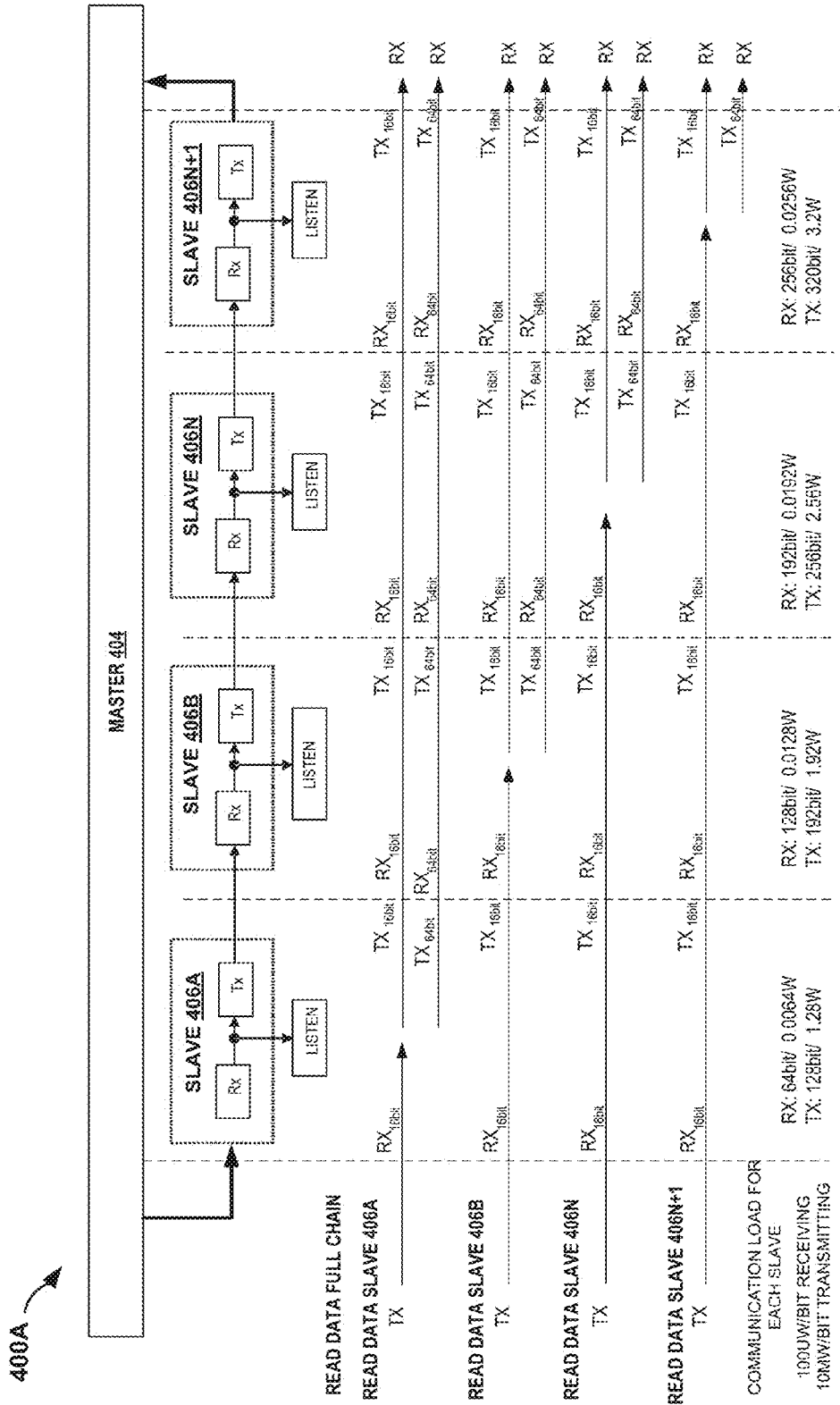

FIG. 4D

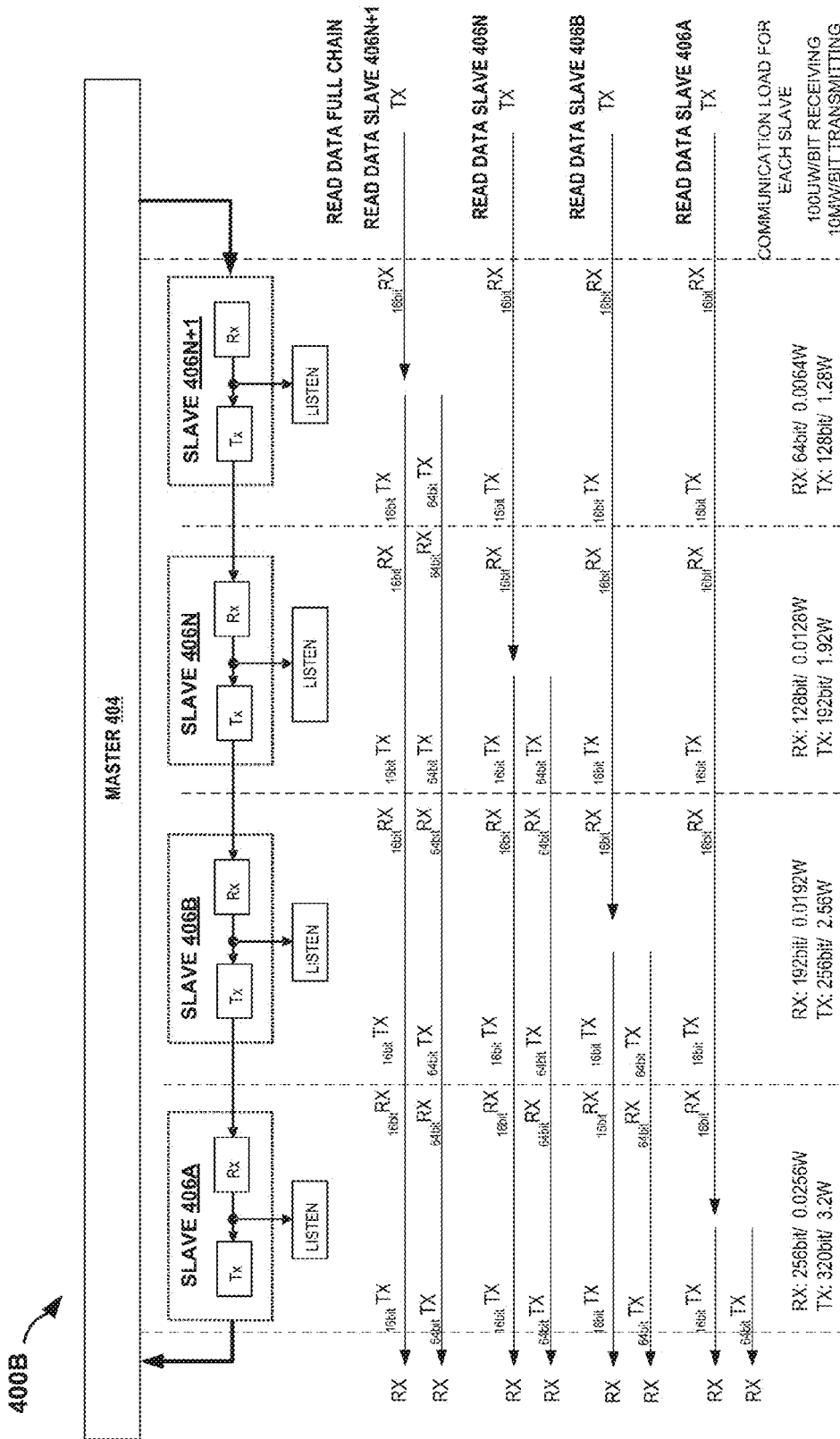

FIG. 4E

Version with changing MoB and MoT Configuration

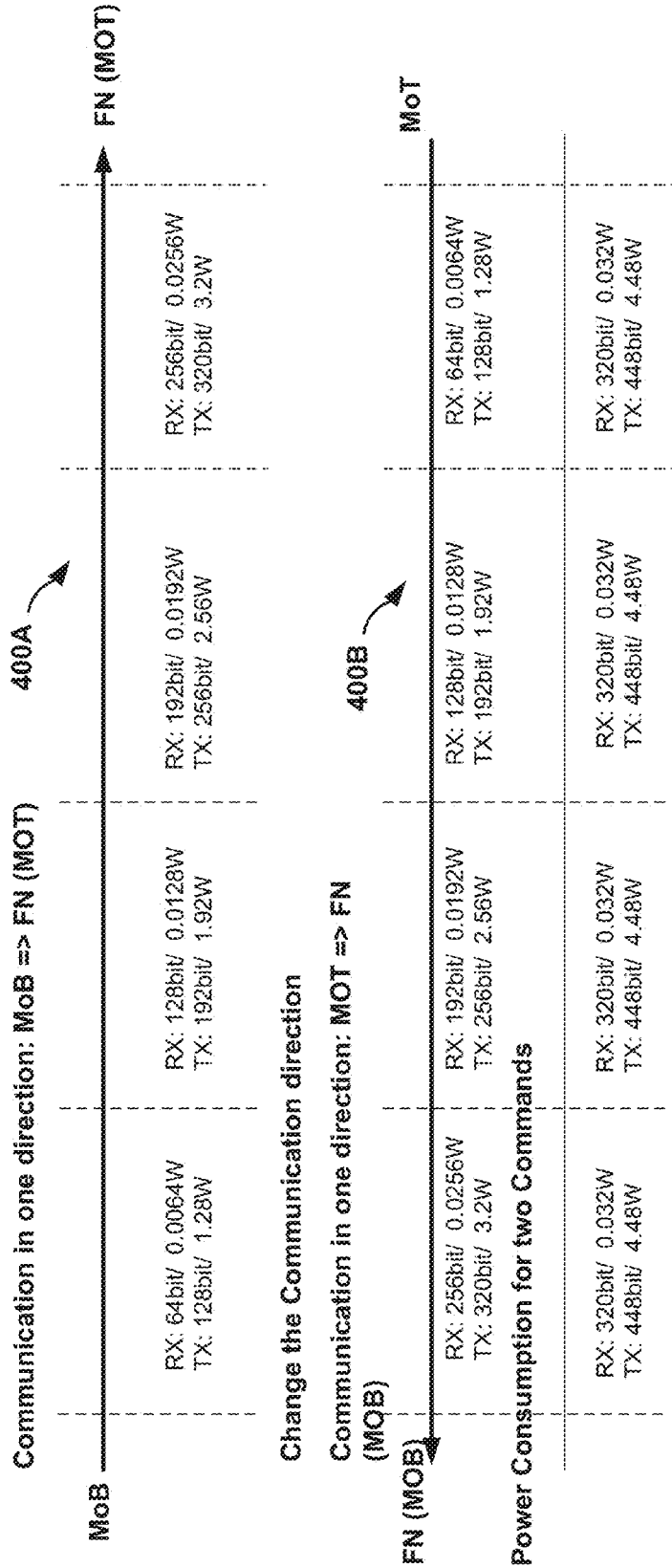

FIG. 4F

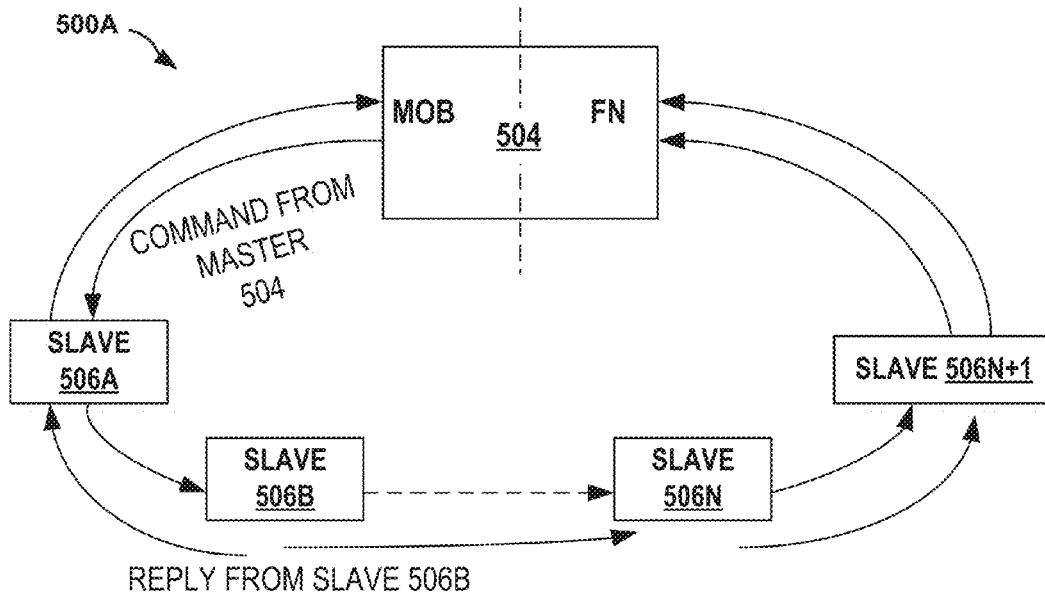

FIG. 5A

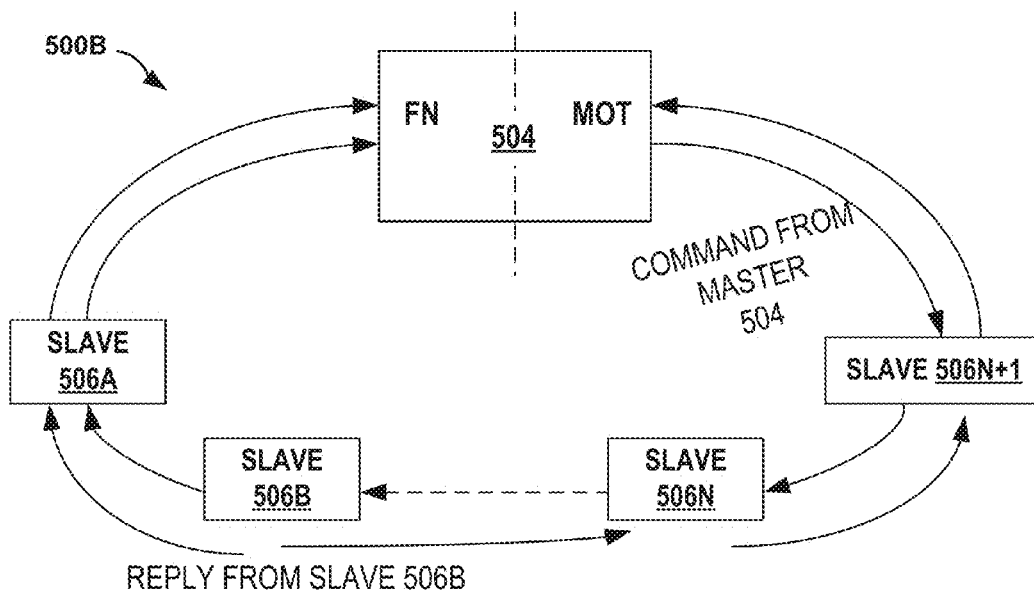

FIG. 5B

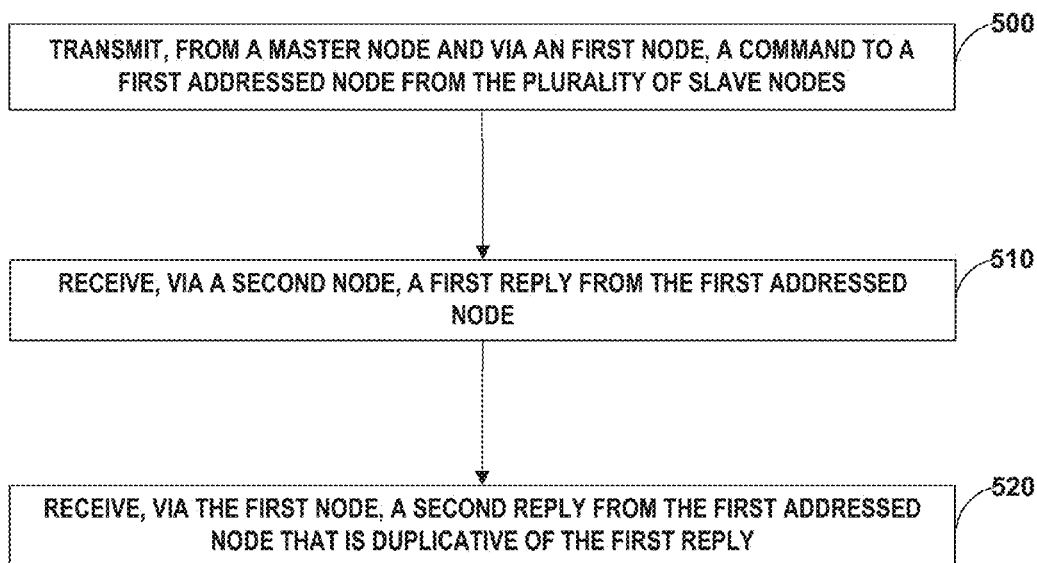

FIG. 5C

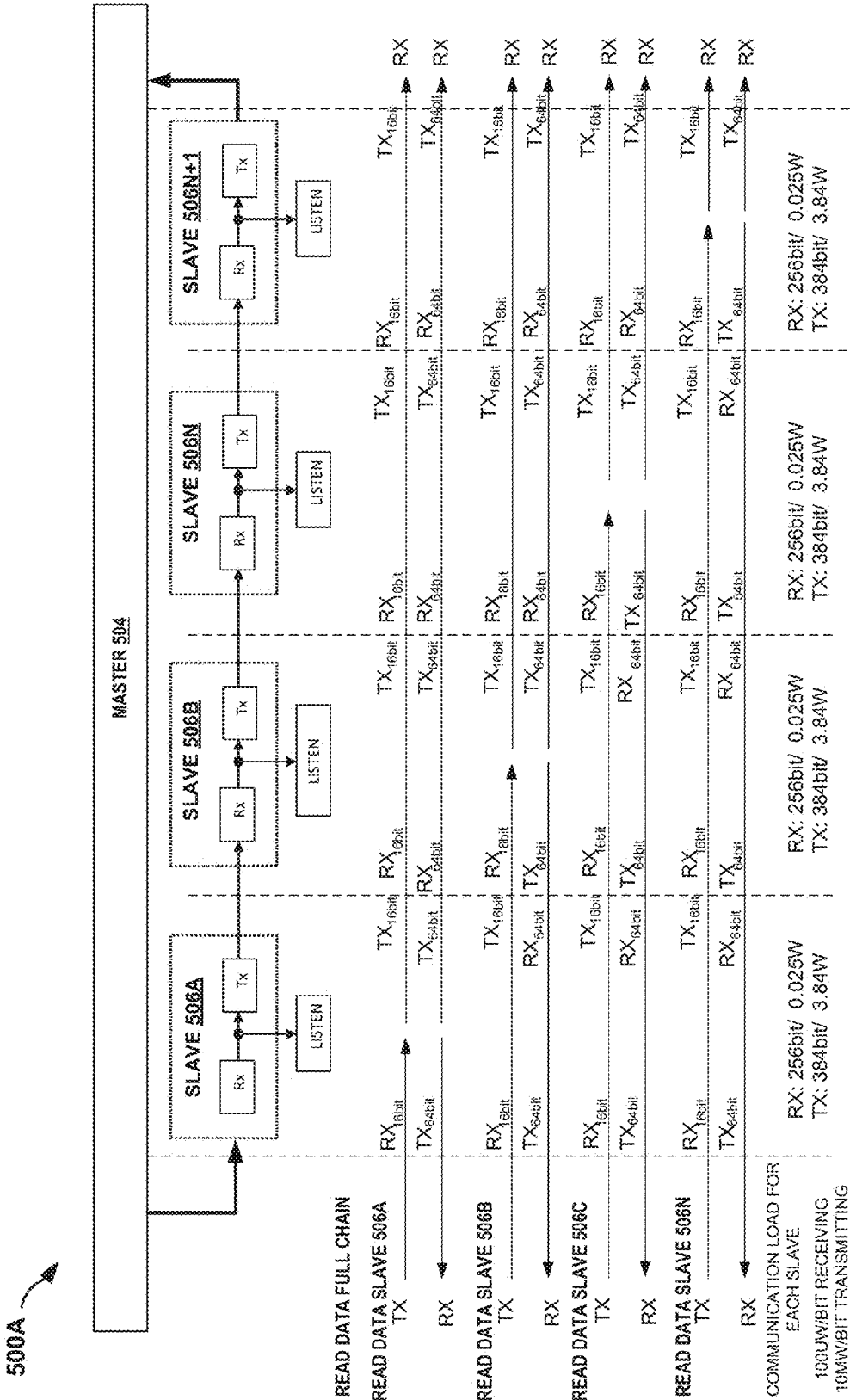

FIG. 5D

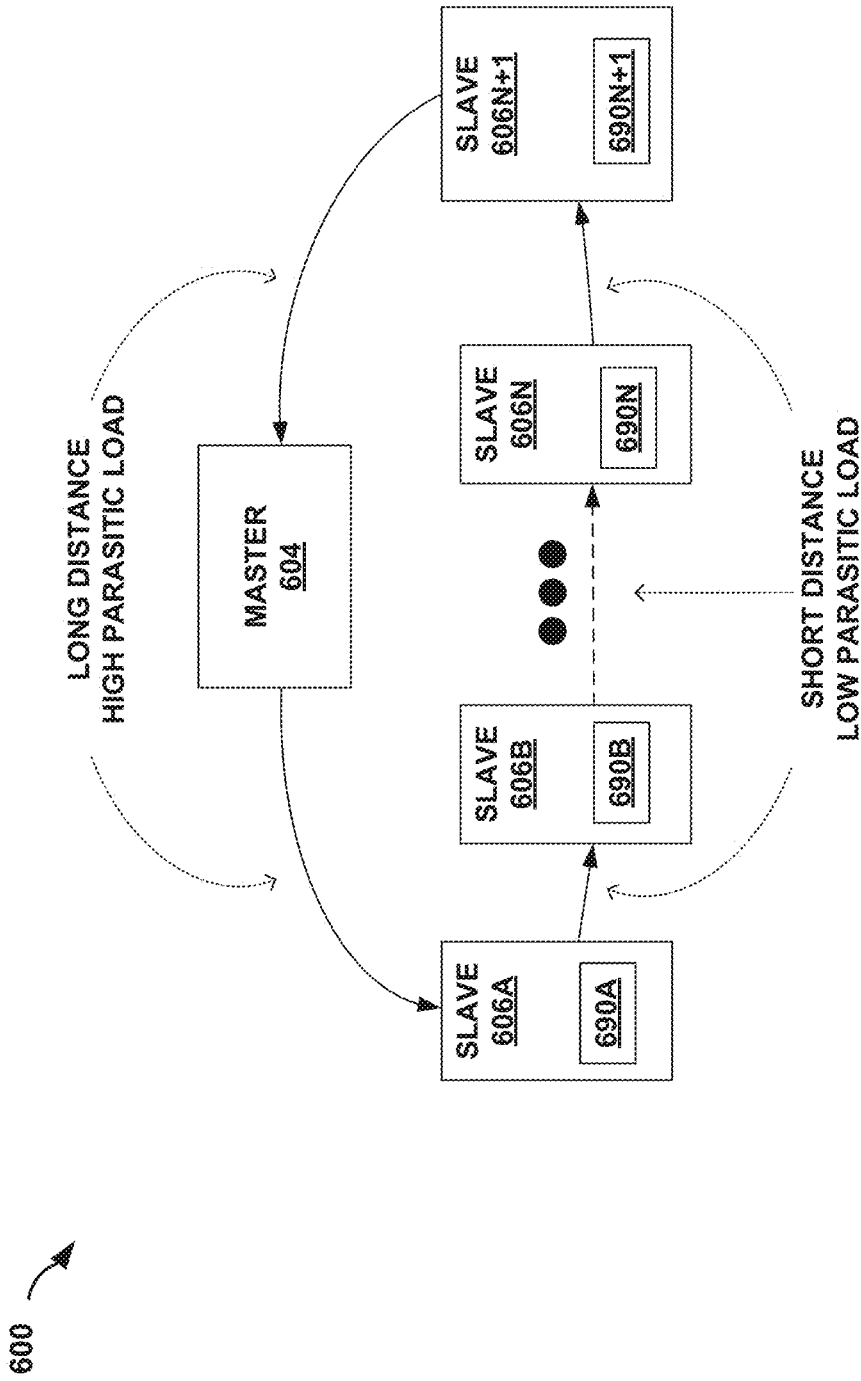

FIG. 6

POWER BALANCING COMMUNICATION FOR BATTERY MANAGEMENT

TECHNICAL FIELD

[0001] The following disclosure relates to battery management systems.

BACKGROUND

[0002] A controller of a battery management system may coordinate the charging and discharging of a high-voltage battery system to ensure that each block or battery cell discharges and charges to the same voltage level. The battery management system may rely on a daisy-chained communication network (e.g., an inter-block communication network) that communicatively couples the controller to each block. The controller may act as a master node located at an initial position in the network and the respective monitoring and balancing circuits (also referred to herein as “balancing and monitoring circuits”) assigned to each block may act as individual slave nodes located at subsequent positions in the network.

[0003] During a broadcast phase of the network, the slave nodes may listen to a low-side bus interface and replicate broadcast data received via the low-side bus interface, via a high-side bus interface and up the chain, until the broadcast data reaches an addressed node. During a reply phase of the network, the direction of bus communication may be inverted. The addressed node may reply to the broadcast by transmitting reply data via the high-side bus interface and back down the chain. Each subsequent slave node in the network, below the addressed node, may replicate the reply data received via the high side bus interface to the low side bus interface until the reply data reaches the master node.

[0004] Each slave node may draw power needed for each phase of communication on the network from its respective battery block. By having to more frequently replicate broadcast and replies on the network, the slave nodes that are positioned towards the start of the chain (e.g., nearest to the master node) may consume more power, over time, than the slave nodes located near the end of the chain (e.g., furthest from the master node). For example, depending on the position of a particular node along the chain, the node may have to communicate a different quantity of bits and may have a different communication load (e.g., due to a variation in wire length and parasitic loads).

[0005] Therefore, implementing an inter-block communication network such as this may lead to an overall imbalance in communication related power consumption amongst the blocks. Since imbalance in the cell system leads to longer charging times and less overall battery capacity, a consistent imbalance in power consumption amongst the blocks due to intrinsically necessary communication power draw is undesired.

SUMMARY

[0006] In general, circuits and techniques are described for enabling a battery management system to balance the power being drawn by the blocks of an inter-block communication network. Rather than automatically terminate a command message at an addressed node in the inter-block communication network, or automatically inverse the direction of communications being transmitted during the reply phase of the inter-block communication network, an example battery

management system may cause command and reply messages to move through the communication network so that, over-time, each node in the network draws approximately the same amount of communication related power from its respective block.

[0007] In one example, the disclosure is directed to a battery management system that includes a controller configured to control electrical charging and discharging of a plurality of blocks of a battery, and an inter-block communication network. The inter-block communication network includes a master node and a plurality of slave nodes arranged in a ring-type daisy-chain configuration with the master node, the master node being coupled to the controller and configured to initiate all command messages sent through the inter-block communication network and terminate all reply messages sent through the inter-block communication network, and the plurality of slave nodes being bounded by an initial node coupled to the master node and a last node coupled to the master node.

[0008] In another example, the disclosure is directed to a method that includes transmitting, by a controller of a battery management system, from a master node of an inter-block communication network and via an initial node from a plurality of slave nodes of the inter-block communication network, a first command to a first addressed node from the plurality of slave nodes, and responsive to transmitting the first command, receiving, by the controller, via a last node from the plurality of slave nodes, a first reply from the first addressed node. The method further includes after receiving the first reply, transmitting, by the controller, from the master node, via the last node, a second command to a second addressed node from the plurality of slave nodes, and receiving, by the controller, via the initial node, a second reply from the second addressed node in response to transmitting the second command.

[0009] In another example, the disclosure is directed to a method that includes transmitting, by a controller of a battery management system, from a master node of an inter-block communication network and via a first node from a plurality of slave nodes of the inter-block communication network, a command to a first addressed node from the plurality of slave nodes. The method further includes, responsive to transmitting the command: receiving, by the controller, via a second node from the plurality of slave nodes, a first reply from the first addressed node, and receiving, by the controller, via the first node, a second reply from the first addressed node that is duplicative of the first reply.

[0010] The details of one or more examples are set forth in the accompanying drawings and the description below. Other features, objects, and advantages of the disclosure will be apparent from the description and drawings, and from the claims.

BRIEF DESCRIPTION OF DRAWINGS

[0011] FIG. 1 is a block diagram illustrating an example battery system configured to balance communication related power consumption of blocks of a battery stack, in accordance with one or more aspects of the present disclosure.

[0012] FIG. 2 is a conceptual diagram illustrating communication related power consumption of a traditional battery system that is configured to implement a traditional inter-block communication network.

[0013] FIG. 3 is a conceptual diagram illustrating communication related power consumption of individual slave nodes of a traditional inter-block communication chain.

[0014] FIGS. 4A and 4B are conceptual diagrams illustrating example inter-block communication networks of an example battery system configured to balance communication related power consumption of blocks of a battery stack, in accordance with one or more aspects of the present disclosure.

[0015] FIG. 4C is a flow diagram illustrating example operations performed by the example battery systems of FIGS. 4A and 4B.

[0016] FIGS. 4D through 4F are conceptual diagrams illustrating communication related power consumption of the example battery systems of FIG. 4A and FIG. 4B.

[0017] FIGS. 5A and 5B are conceptual diagrams illustrating example inter-block communication networks of an example battery system configured to balance communication related power consumption of blocks of a battery stack, in accordance with one or more aspects of the present disclosure.

[0018] FIG. 5C is a flow diagram illustrating example operations performed by the example battery systems of FIGS. 5A and 5B.

[0019] FIGS. 5D and 5E are conceptual diagrams illustrating communication related power consumption of the example battery system of FIGS. 5A and 5B.

[0020] FIG. 6 is a conceptual diagram illustrating an example inter-block communication network of an example battery system configured to balance communication related power consumption of blocks of a battery stack, in accordance with one or more aspects of the present disclosure.

DETAILED DESCRIPTION

[0021] In general, circuits and techniques are described for enabling a battery management system to balance the power being drawn by the blocks of an inter-block communication network. The example inter-block communication network may include a ring-type, daisy-chain of slave nodes with a first slave node in the chain being coupled to a master node that is coupled to the controller. Unlike other inter-block communication networks of other battery systems, the example inter-block communication network of the example battery system is not simply terminated by a final slave node in the network. Instead, the example inter-block communication network is configured in a ring topology in which both the first slave node and the final slave node in the daisy-chain are coupled to the master node. Rather than automatically terminating a command message at an addressed node in the inter-block communication network, or automatically inverting the direction of communications during the reply phase of the inter-block communication network, the ring topology of the example inter-block communication network enables the inter-block communication network to transmit command and reply messages through the network so that, over-time, each node in the network draws approximately the same amount of communication related power from its respective block.

[0022] For example, in some versions, an example inter-block communication network acts as an alternating master-on-top (MoT) and master-on-bottom (MoB) network. In the alternating MoT and MoB implementation, the slave nodes of the inter-block communication network may be configured to forward command messages through the entire

communication network (e.g., without terminating the command message at an addressed node) and may be further configured to send reply messages in the same direction in which command messages are received. Lastly, the controller of the alternating MoT and MoB implementation may cause the master node to alternate, after transmission of each command message, the direction that the master node broadcasts a command message to the network.

[0023] In other versions, an example inter-block communication network acts as a fixed MoT or MoB network. In the fixed MoT or MoB implementation, the slave nodes of the inter-block communication network may be configured to forward command messages through the entire communication network (e.g., without terminating the command message at an addressed node). Unlike the alternating MoT and MoB implementation however, the slave nodes may be further configured to send instances of reply messages in the both direction through the network. In other words, an addressed node may send a first instance of a reply message in the same direction in which command messages are received as well as a second instance of the same reply message in the opposite direction in which the command message was received.

[0024] In this way, each version of the example inter-block communication network described herein may balance the amount of communication related power being drawn by each slave node from its respective battery block. By evenly distributing, over-time, the quantity of command and reply broadcasts that each slave node has to perform on the network, each slave node on the network may consume approximately the same amount of power communicating on the network. Implementing an example inter-block communication network such as this may lead to an overall balance in communication related power consumption amongst the blocks. A consistent balance in communication related power consumption amongst the blocks may cause an overall, reduced charging time of the battery system.

[0025] FIG. 1 is a block diagram illustrating system 100 as an example battery system configured to balance communication related power consumption of blocks of a battery stack, in accordance with one or more aspects of the present disclosure. System 100 represents any type of battery management system, particularly in the field of high-voltage battery management. For example, system 100 may form part of an electric energy storage system of an electric or hybrid-electric automobile, a commercial or home electrical energy storage system, or any other type of electrical energy storage system that relies on an inter-block communication system to manage energy storage at individual battery blocks of the system. System 100 includes controller 112, battery stack 120, master node 104, an “n+1” quantity of slave nodes 106A-106N+1 (collectively “slave nodes 106”), and an “n+2” quantity of coupling elements 108A-108N+1 (collectively “coupling elements 108”), where n is any integer greater than or equal to one.

[0026] Battery stack 120 represents a high-voltage battery system that includes any quantity of series connected, and lower-voltage, battery cells that store electrical energy used to power a system (e.g., an electric propulsion system for an automobile). The voltage of battery stack 120 at a particular time corresponds to a sum of the individual voltage of each cell in battery stack 120 at that time. For example, battery stack 120 may include one hundred fifty individual battery cells that when combined in series, provide the voltage

required by system 100. To facilitate battery management of system 100, the battery cells of battery stack 120 may be grouped into blocks of one or more cells with each block having its own monitoring and balancing electronics. For example, each block may include a single cell, twelve cells, fourteen cells, sixteen cells, or any other quantity of cells that may be required for battery management.

[0027] Controller 112 performs functions related to battery management on behalf of system 100 including being configured to control electrical charging and discharging of a plurality of blocks of a battery stack 120. As some examples, controller 112 may monitor the overall voltage of battery stack 120 as well as the voltage of the individual blocks of battery stack 120 to determine whether to initiate charging or enable discharging of the electrical energy stored by battery stack 120. Controller 112 may comprise any suitable arrangement of hardware, software, firmware, or any combination thereof, to perform the techniques attributed to controller 112 that are described herein. Controller 112 may be coupled to master node 104 via a communication interface that controller 112 shares with master node 104 (e.g., a serial peripheral interface [SPI] bus). Controller 112 may initiate a command via master node 104 that is addressed to one or more of slave nodes 106 and causes the one or more addressed node to report back a voltage status in a reply. Controller 112 and master node 104 may be powered separately from slave nodes 106 and therefore do not draw current from a cell of battery stack 120, therefore does not generate communication related power imbalance.

[0028] Controller 112 may include any one or more microprocessors, digital signal processors (DSPs), application specific integrated circuits (ASICs), field programmable gate arrays (FPGAs), or any other equivalent integrated or discrete logic circuitry, as well as any combinations of such components. When controller 112 includes software or firmware, controller 112 further includes any necessary hardware for storing and executing the software or firmware, such as one or more processors or processing units. In general, a processing unit may include one or more microprocessors, DSPs, ASICs, FPGAs, or any other equivalent integrated or discrete logic circuitry, as well as any combinations of such components.

[0029] Master node 104, slave nodes 106, and coupling elements 108 form an inter-block communication network of system 100. Master node 104 and slave nodes 106 are arranged in a ring-type daisy-chain configuration along a low-side bus and a high-side bus. Master node 104 is coupled to controller 112 and configured to initiate all command messages sent through the inter-block communication network over the high-side bus and terminate all reply messages sent through the inter-block communication network via the low-side bus. Each of master node 104 and slave nodes 106 is communicatively coupled to the low side bus and high-side bus of the inter-block communication network via one or more of coupling elements 108. Due to their relative positioning with respect to master node 104, slave nodes 106 are bounded by slave node 106A which acts as an initial node coupled to master node 104 and slave node 106N+1 which acts as a last node or "final node" coupled to master node 104.

[0030] Each of coupling elements 108 represents an individual RC (resistor-capacitor) or RCL (resistor-capacitor-inductor) type coupling circuit for communicatively cou-

pling nodes 104 and 106 to the low-side and high-side buses of the inter-block communication network of system 100. For example: when communicating up the chain (e.g., in a direction that goes from master node 104 via slave node 106A and to slave node 106N+1) slave node 106A may listen, via coupling element 108A, to the low-side and high-side bus in order to detect a command being transmitted from master node 104 slave node 106B may listen, via coupling element 108B, to the low-side and high-side bus in order to detect a command or reply being relayed up the chain from slave node 106A, and so on. Similarly, when communicating down the chain (e.g., in a direction that goes from master node 104 via slave node 106N+1 and to slave node 106A) slave node 106N+1 may listen, via coupling element 108N+1, to the low-side bus and high-side bus in order to detect a command being transmitted from master node 104; slave node 106B may listen, via coupling element 108N, to the low-side and high-side bus in order to detect a command or reply being relayed down the chain from slave node 106N+1, and so on.

[0031] Each of slave nodes 106 includes monitoring and balance electronics associated with a different battery block of battery stack 120. For example, slave nodes 106 may each include a voltage monitoring circuit that detects the voltage level of a particular battery block of battery stack 120 and reports the detected voltage back as data to controller 112. As described in greater detail below, each of slave nodes 106 may include a respective current balancing unit to compensate for variations in power consumption due to differences in parasitic capacitances amongst the transmission lines that are coupling nodes 104 and 106 to the network. Each of slave nodes 106 also includes communication electronics for interpreting a command based on data received from controller 112 and packaging a measured voltage level into data for a reply message that gets transmitted back to controller 112. Each slave node 106 may draw power needed for each phase of communication (e.g., transmit and reply) on the network from its respective battery block.

[0032] As an example, slave node 106A may receive a command message via the inter-block communication network from master node 104, determine the command message is addressed to slave node 106A, and perform an action in response to the command (e.g., slave node 106A may close a switch that completes a voltage detection circuit for measuring the voltage level of a battery block of stack 120). Slave node 106A may package the detected voltage into a data reply message and send the data reply message via the inter-block communication network back to master node 104.

[0033] As described below in greater detail, by arranging master node 104 and slave nodes 106 in a ring-type (also referred to herein as being "circular") daisy-chain configuration, controller 112 may cause each of slave nodes 106 to draw approximately the same amount of power performing communication related operations of system 100.

[0034] Controller 112 may cause commands from master node 104 to pass all slave nodes 106 from one side of the daisy-chain and come back to master node 104 from the other side of the daisy-chain. Controller 112 may further cause replies from slave nodes 106 to reach master node 104 from both sides of the daisy-chain.

[0035] Controller 112 may cause master node 104 and slave nodes 106 to, over-time, transmit and receive the same quantity of command and reply messages on the network. In

doing so, regardless as to the position of each of slave nodes **106** along the chain relative to master node **104**, controller **112** may cause each of nodes **106** to, over time, consume the same amount of communication related power from each of their respective battery blocks of stack **120**. Controller **112** may cause each slave node **106** to have the same communication load requiring each slave node **106** to transmit and receive the same quantity of bits.

[0036] In this way, controller **112** may enable battery stack **120** to experience a shorter balancing time than battery systems that rely on other types of battery management systems. The shorter balancing time may enable battery stack **120** to have a faster charging time a compared to these other battery systems.

[0037] FIG. 2 is a conceptual diagram illustrating communication related power consumption of system **200** which represents a traditional battery management system that is configured to implement a traditional (i.e., non-circular) inter-block communication protocol. System **200** includes master node **204** coupled to a controller (not shown in FIG. 2) and slave nodes **206A-206N+1**. System **200** includes a traditional, non-circular daisy chain inter-block communication network, in other words, unlike system **100** of FIG. 1 that includes a ring-type or circular daisy-chain inter-block communication network, the communication network made up of master node **104** and slave nodes **106** is non-circular and instead has a definite, initial position and a definite, final position. Slave node **206A** of system **200** is at the initial position of the non-circular daisy-chain and slave node **206N+1** is at the final position of the non-circular daisy-chain.

[0038] Every command being transmitted from master **204** enters the communication network of system **200** via slave **206A**. Each of slave nodes **206A** may listen to a low-side bus interface and replicate the command data received via the low-side bus interface, via a high-side bus interface and up the chain, until the command data reaches an addressed node (e.g., equaling any one of slave nodes **206** up to and including slave node **206N+1**). During a reply phase of the network, the direction of bus communication may be inverted. The addressed node **206** may reply to the command by transmitting reply data via the high-side bus interface and back down the chain. Each subsequent slave node **206** in the network, below the addressed node **206**, may replicate the reply data received via the high side bus interface to the low side bus interface until the reply data reaches master node **204**.

[0039] By having to more frequently replicate broadcast and replies on the network, the one or more slave nodes **206** (e.g., slave node **206A**) that are positioned towards the start of the chain (e.g., nearest to master node **204**) may consume more power, over time, than the one or more slave nodes **206** (e.g., slave node **206N+1**) located near the end of the chain (e.g., furthest from the master node **204**). For example, FIG. 2 shows the total quantity of bits and amount of power drawn by each of slave nodes **206** during sequential commands down the chain.

[0040] During an initial command addressed to slave node **206A**, slave node **206A** may receive 16 bits of data from master **204** and in response transmit 64 bits of data. During a subsequent command addressed to slave node **206B**, slave node **206A** may receive a total of 16+64 bits of data and transmit a total of 64+16 bits of data, while slave node **206B** may receive 16 bits of data and transmit a total of 64 bits of

data. During a third command addressed to slave node **206N**, slave node **206A** and slave node **2069** may each receive a total of 16+64 bits of data and transmit a total of 64+16 bits of data, while slave node **206N** may receive 16 bits of data and transmit a total of 64 bits of data. Lastly, during a final command addressed to slave node **206N+1**, slave nodes **206A**, **2069**, and **206N** may each receive a total of 16+64 bits of data and transmit a total of 64+16 bits of data, while slave node **206N+1** may receive 16 bits of data and transmit a total of 64 bits of data. In total, over the course of the four transmissions, each of slave nodes **206** draws a different amount of power from its respective battery cell as slave node **206A** may transmit 304 bits of data and receive 256 bits of data, slave node **2069** may transmit 224 bits of data and receive 176 bits of data, slave node **206N** may transmit 144 bits of data and receive 96 bits of data, and slave node **206N+1** may transmit 64 bits of data and receive 16 bits of data.

[0041] Therefore, implementing a traditional inter-block communication network such as the network shown in FIG. 2 shows that a non-circular inter-block communication protocol may lead to an overall imbalance in communication related power consumption amongst the blocks of a battery system. Since imbalance in the cell system leads to longer charging times and less overall battery capacity, a consistent imbalance in power consumption amongst the blocks due to intrinsically necessary communication power draw is undesired.

[0042] FIG. 3 is a conceptual diagram illustrating communication related power consumption of individual slave nodes of a traditional inter-block communication chain such as the inter-block communication chain of system **200** of FIG. 2. For ease of description, FIG. 3 is described within the context of system **200** of FIG. 2. FIG. 3 shows chart **300** which illustrates the total, communication related power consumption (e.g., watts) of each of slave nodes **206** depending on the total quantity "n" of slave nodes.

[0043] For example, waveform **310** shows the projected amount of power consumed by slave node **206A** which is the initial slave node in a non-ring-type or non-circular inter-block communication network, waveform **320** shows the projected power consumed by slave node **206B** which is the second slave node in a non-ring-type or non-circular inter-block communication network, waveform **330** shows the projected power consumed by slave node **206N** which is the third slave node in a non-ring-type or non-circular inter-block communication network, and waveform **340** shows the projected power consumed by slave node **206N+1** which is the final slave node (FN) in a non-ring-type or non-circular inter-block communication network.

[0044] As shown in FIG. 3 and a comparison between waveforms **310-340**, when a non-ring-type or non-circular inter-block communication network includes twelve slave nodes, the final node needs approximately $\frac{1}{3}$ the power of slave node **206A** (e.g., the initial slave node in the chain). This imbalance of communication power being drawn from the blocks of cells of a battery system may result in a longer passive balancing, resulting in a longer charging time.

[0045] FIGS. 4A and 4B are conceptual diagrams illustrating systems **400A** and **400B**, respectively, as example battery systems configured to balance communication related power consumption of blocks of a battery stack, in accordance with one or more aspects of the present disclosure. Systems **400A** and **400B** each include master node **404**

and a plurality of slave nodes **406A-406N+1** (collectively “slave nodes **406**”). Master node **404** is analogous to master node **104** of system **100** and slave nodes **406** are each analogous to slave nodes **106** of system **100**. Systems **400A** and **400B** are described below in the context of system **100** of FIG. 1. Although not shown, systems **400A** and **400B** may include coupling elements, a battery stack and a controller that are analogous to coupling elements **108**, battery stack **120** and controller **112** of system **100**. Systems **400A** and **400B** are described below as being controlled by controller **112** of system **100**.

[0046] System **400A** and system **400B** together, show a first version of the ring-type communication network of system **100** in which controller **112** may cause the ring-type inter-block communication network to alternate between MoT mode and MoB mode. System **400A** shows an example of system **100** operating in MoB mode to implement the ring-type communication network of system **100** and system **400B** shows an example of system **100** operating in MoT mode to implement the ring-type communication network of system **100**. Controller **112** may be configured to control the inter-block communication network of systems **100** by alternating between the one-way MoB messaging scheme illustrated as system **400A** of FIG. 4A and the one-way MoT messaging scheme illustrated as system **400B** of FIG. 4B.

[0047] With reference to FIG. 4A, when controlling an inter-block communication network in a one-way MoB messaging scheme, controller **112** may cause master node **404** to transmit, via the initial node **406A**, a command to an addressed node (e.g., any of nodes **406**) and receive, via the last node or final node **406N**, a reply from the addressed node. For example, controller **112** may cause master node **404** to transmit a command that is addressed to slave node **406B** by initially transmitting the command to slave node **406A**. Slave node **406A** may relay the command to slave node **406B**. Upon receipt of the command from master node **404**, slave node **406B** may send a reply up the chain to slave nodes **406N** and **406N+1** until the reply reaches master node **404**.

[0048] In addition to transmitting the reply up the chain, slave node **406B** may also relay the original command received from master node **404**. In other words controller **112** may be further configured to cause the addressed node **406B** to forward, through the inter-block communication network and to the last node **406N+1**, the command and the reply when controlling the inter-block communication network in the one-way MoB messaging scheme. In the end, master node **404** receives from slave node **406N+1**, a copy of the original command that master node **404** transmitted to slave node **406A** as well as a reply from slave node **406B**.

[0049] In the example above, slave nodes **406A** and **406B** may have consumed a lesser amount of power implementing the one-way MoB messaging scheme as compared to all the other slave nodes **406**. That is, each of slave nodes **406N-406N+1** received copies of the command and reply and transmitted copies of the command and reply whereas slave node **406A** only received and transmitted a copy of the command and slave node **406B** only received a copy of the command and transmitted copies of the command and reply.

[0050] In order to balance out the power consumed by the ring-type inter-block communication network, controller **112** may alternate the messaging scheme in a subsequent command such that system **100** implements the one-way MoT messaging scheme illustrated as system **400B** of FIG.

4B. In other words, in some examples, controller **112** may be configured to switch between controlling the inter-block communication network using the one-way MoT messaging scheme or the one-way MoB messaging scheme each time the master node receives the reply.

[0051] With reference to FIG. 4B, when controlling an inter-block communication network in a one-way MoT messaging scheme, controller **112** may cause master node **404** to transmit, via the last node or final node **406N**, a command to an addressed node and receive, via the initial node **406A**, the reply from the addressed node. For example, controller **112** may cause master node **404** to transmit a command that is addressed to slave node **406B** by initially transmitting the command to slave node **406N+1**. Slave node **406N+1** may relay the command down the chain to slave node **406N**, which relays the command further down the chain until eventually slave node **406B** receives the command. Upon receipt of the command from master node **404**, slave node **406B** may send a reply down the chain to slave nodes **406A** until the reply reaches master node **404**.

[0052] In addition to transmitting the reply down the chain, slave node **406B** may also relay the original command received from master node **404**. That is, controller **112** may be further configured to cause the addressed node **406B** to forward, through the inter-block communication network and to the initial node **406A**, the command and the reply when controlling the inter-block communication network in the one-way MoT messaging scheme. In the end, master node **404** receives from slave node **406A**, a copy of the original command that master node **404** transmitted to slave node **406N+1** as well as a reply from slave node **406B**.

[0053] This time, in the example above, slave nodes **406A** and **406B** may have consumed a greater amount of power implementing the one-way MoT messaging scheme as compared to all the other slave nodes **406**. That is, each of slave nodes up the chain from slave node **406B** only received copies of the command and only transmitted copies of the command whereas slave node **406B** received and transmitted a copy of the command and transmitted a copy of the reply, and slave node **406A** both received and transmitted copies of the command and reply. However, the resulting imbalance from the one-way MoT transmission is offset by the resulting imbalance from the earlier one-way MoB type transmission. That is, by alternating between a one-way MoT communication scheme and a one-way MoB communication scheme, controller **112** may cause the inter-block communication network to consume a balanced amount of power across all slave nodes in the network.

[0054] FIG. 4C is a flow diagram illustrating example operations performed by the example battery systems of FIGS. 4A and 4B. FIG. 4C is described below in the context of controller **112** of system **100** of FIG. 1 controlling the components of systems **400A** and **400B** of FIGS. 4A and 4B.

[0055] In operation, controller **112** may transmit, from a master node, a first command to a first addressed node from a plurality of slave nodes (**400**). For example, when operating in MoB mode, controller **112** may cause master node **404** to transmit a command that is addressed to slave node **406B** via slave node **406A**. Slave node **406A** may forward the command up the chain to slave node **406B**. Slave node **406B** may receive the forwarded command and in response, forward the command and a reply to the command further up the chain to slave nodes **406N** and **406N+1**.

[0056] Responsive to transmitting the first command, controller 112 may receive, via a last node from the plurality of slave nodes, a first reply from the first addressed node (410). For example, controller 112 may receive, from master node 404, a copy of the reply from addressed node 406B that master node 404 receives from slave node 406N+1.

[0057] Controller 112 may receive, via the last node 406N+1, the first command being forwarded through the inter-block communication network by the first addressed node 406B (420). For example, in addition to receiving the copy of the reply, controller 112 may receive, from master node 404 and via slave node 406N+1, a copy of the first command that was sent by master node 404 to addressed node 406B.

[0058] After receiving the first reply, controller 112 may transmit, from the master node, via the last node, a second command to a second addressed node from the plurality of slave nodes (430). For example, controller 112 may switch to MoT mode. While operating in MoT mode, controller 112 may cause master node 404 to transmit a command that is addressed to slave node 406B via slave node 406N+1. Slave node 406N+1 may forward the command down the chain to slave node 406B. Slave node 406B may receive the forwarded command and in response, forward the command and a reply to the command further down the chain to initial node 406A.

[0059] Controller 112 may receive, via the initial node, a second reply from the second addressed node in response to transmitting the second command (440). For example, controller 112 may receive, from master node 404, a copy of the reply from addressed node 406B that master node 404 receives from slave node 406A.

[0060] Controller 112 may receive, via the initial node, the second command being forwarded through the inter-block communication network by the second addressed node (450). For example, in addition to receiving the copy of the reply, controller 112 may receive, from master node 404 and via slave node 406A, a copy of the second command that was sent by master node 404 to addressed node 406B.

[0061] FIGS. 4D through 4F are conceptual diagrams illustrating communication related power consumption of the example battery systems of FIG. 4A and FIG. 4B. FIGS. 4D through 4F are described in the context of FIG. 1 and FIGS. 4A through 4C.

[0062] As shown in FIG. 4D, when controller 112 is operating in MoB mode, every command being transmitted from master 404 enters the communication network of system 400A via slave 406A. Each of slave nodes 406 may replicate command data up the chain, until the command data reaches a last node or a final node 406N+1 and at which point exits the network back to master 404. During a reply phase of the network, the direction of bus communication may continue to move in the same direction as during the command phase. The addressed node 406 may reply to the command by transmitting reply data up the chain until the command data reaches a last node or a final node 406N+1 and at which point exits the network back to master 404.

[0063] As shown in FIG. 4E, when controller 112 is operating in MoT mode, every command being transmitted from master 404 enters the communication network of system 400B via slave 406N+1. Each of slave nodes 406 may replicate command data down the chain, until the command data reaches an initial node 406A and at which point exits the network back to master 404. During a reply

phase of the network, the direction of bus communication may continue to move in the same direction as during the command phase. The addressed node 406 may reply to the command by transmitting reply data down the chain until the command data reaches an initial node 406A and at which point exits the network back to master 404.

[0064] As shown in FIG. 4F, the power consumption for two commands, the first moving up the chain in MoB mode and the second moving down the chain in MoT mode, causes each of slave nodes 406 to transmit the same quantity of bits and therefore consume approximately the same amount of power. Note: FIG. 4F illustrates an ideal situation in which all commands and responses through the system have an equal bit length. This communication scheme may therefore prevent an overall imbalance in communication related power consumption amongst the blocks of a battery system and lead to a faster charging time as compared to other battery management communication systems. In addition, by sending the command through the entire chain, master node 404 can double check that the chain is accurately receiving its commands.

[0065] FIGS. 5A and 5B are conceptual diagrams illustrating example battery systems configured to balance communication related power consumption of blocks of a battery stack, in accordance with one or more aspects of the present disclosure. Systems 500A and 500B each include master node 504 and a plurality of slave nodes 506A-506N+1 (collectively "slave nodes 506"). Master node 504 is analogous to master node 104 of system 100 and slave nodes 506 are each analogous to slave nodes 106 of system 100. Systems 500A and 500B are described below in the context of system 100 of FIG. 1. Although not shown, systems 500A and 500B may include coupling elements, a battery stack and a controller that are analogous to coupling elements 108, battery stack 120 and controller 112 of system 100. Systems 500A and 500B are described below as being controlled by controller 112 of system 100.

[0066] System 500A and system 500B show two examples of a second version of the ring-type communication network of system 100 in which controller 112 may cause the ring-type inter-block communication network to operate in a fixed, MoT mode or a fixed MoB mode. System 500A shows an example of system 100 operating in a fixed MoB mode to implement the ring-type communication network of system 100 and system 500B shows an example of system 100 operating in a fixed MoT mode to implement the ring-type communication network of system 100. Unlike systems 400A and 400B in which controller 112 alternated between MoB and MoT modes, controller 112 may be configured to control the inter-block communication network of systems 100 by implementing either the one-way MoB messaging scheme illustrated as system 500A of FIG. 5A or by implementing the one-way MoT messaging scheme illustrated as system 500B of FIG. 5B.

[0067] With reference to FIG. 5A, when controlling an inter-block communication network in a fixed, one-way MoB messaging scheme, controller 112 may cause master node 504 to transmit, via the initial node 506A, a command to an addressed node (e.g., any of nodes 506) and receive, via the last node or final node 506N+1, a first reply from the addressed node and also receive, via the initial node 506A, a second reply that is duplicative of the first reply. For example, controller 112 may cause master node 504 to transmit a command that is addressed to slave node 506B by

initially transmitting the command to slave node **506A**. Slave node **506A** may relay the command to slave node **506B**. Upon receipt of the command from master node **504**, slave node **506B** may send a reply up the chain to slave nodes **506N** and **506N+1** until the reply reaches master node **504**. In addition to the reply being sent up the chain, slave node **506B** may send a reply down the chain to slave nodes **506A** until the reply reaches master node **504**.

[0068] In addition to transmitting replies up and down the chain, slave node **506B** may also relay the original command received from master node **504** up the chain. In other words controller **112** may be further configured to cause the addressed node **506B** to forward, through the inter-block communication network and to the last node **406N+1**, the command and the reply when controlling the inter-block communication network in the fixed one-way MoB messaging scheme. In the end, master node **504** receives from slave node **506N+1**, a copy of the original command that master node **504** transmitted to slave node **506A** as well as a reply from slave node **506B** and master node **504** additionally receives from slave node **506A** a second copy of the reply from slave node **506B**.

[0069] With reference to FIG. **5B**, when controlling an inter-block communication network in a fixed, one-way MoT messaging scheme, controller **112** may cause master node **504** to transmit, via the last node **506N+1**, a command to an addressed node (e.g., any of nodes **506**) and receive, via the initial node **506A**, a first reply from the addressed node and also receive, via the last node node **506N+1**, a second reply that is duplicative of the first reply. For example, controller **112** may cause master node **504** to transmit a command that is addressed to slave node **506B** by initially transmitting the command to slave node **506N+1**. Slave node **506N+1** may relay the command to slave node **506B**. Upon receipt of the command from master node **504**, slave node **506B** may send a reply down the chain to slave node **506A** until the reply reaches master node **504**. In addition to the reply being sent down the chain, slave node **506B** may send a reply up the chain to slave nodes **506N+1** until the reply reaches master node **504**.

[0070] In addition to transmitting replies up and down the chain, slave node **506B** may also relay the original command received from master node **504** down the chain. In other words controller **112** may be further configured to cause the addressed node **506B** to forward, through the inter-block communication network and to the initial node **506A**, the command and the reply when controlling the inter-block communication network in the fixed one-way MoT messaging scheme. In the end, master node **504** receives from slave node **506A**, a copy of the original command that master node **504** transmitted to slave node **506N+1** as well as a reply from slave node **506B** and master node **504** additionally receives from slave node **506N+1** a second copy of the reply from slave node **506B**.

[0071] Whether implemented as a MoB network or a MoT network, controller **112** may cause commands and replies to be sent throughout the chain of systems **500A** and **500B**. In this way, controller **112** may balance out the power consumed by the ring-type inter-block communication network. In addition, by sending the command and the reply, through the entire chain, master node **504** can double check that the chain is accurately receiving its commands and that master

node **504** is accurately receiving the reply. Furthermore, the data from slave to master is fail-safe as replies have two paths to return to the master.

[0072] FIG. **5C** is a flow diagram illustrating example operations performed by the example battery systems of FIGS. **5A** and **5B**. FIG. **5C** is described below in the context of controller **112** of system **100** of FIG. **1** controlling the components of systems **500A** and **500B** of FIGS. **5A** and **5B**.

[0073] In operation, with reference to FIG. **5A**, when implementing a fixed MoB scheme, controller **112** may transmit, from master node and via a first node from a plurality of slave nodes, a command to a first addressed node from the plurality of slave nodes (**500**). For example, controller **112** may cause master node **504** to send a command to slave node **506B**, via slave node **506A**, which replicates the command up the chain until to slave node **506B**. In this case, slave node **506A** acts as the “first node” in the chain.

[0074] Controller **112** may receive, via a second node from the plurality of slave nodes, a first reply from the first addressed node (**510**). For example, controller **112** may receive from master node **504** a reply to the command. The reply may arrive at master **504** by way of slave node **506N+1** after slave node **506B** transmits the reply up the chain. In this case, slave node **506N+1** acts as the “second node” in the chain.

[0075] Controller **112** may further receive, via the first node, a second reply from the first addressed node that is duplicative of the first reply (**520**). For example, controller **112** may receive from master node **504** a second reply to the command, the second reply may arrive at master **504** by way of slave node **506A** after slave node **506B** transmits a duplicate of the reply down the chain.

[0076] With reference to FIG. **5B**, when implementing a fixed MoT scheme, controller **112** may repeat operations **500-520**, however, rather than slave node **506A** acting as the “first node” and slave node **506N+1** acting as the “second node”, their roles are reversed. In other words, slave node **506N+1** may act as the “first node” and slave node **506A** may act as the “second node”.

[0077] FIGS. **5D** and **5E** are conceptual diagrams illustrating communication related power consumption of the example battery system of FIGS. **5A** and **5B**. FIGS. **5D** and **5E** are described in the context of FIG. **1** and FIGS. **5A** through **5C**.

[0078] As shown in FIG. **5D**, when controller **112** is operating in fixed MoB mode, every command being transmitted from master **504** enters the communication network of system **500A** via slave **506A**. Each of slave nodes **506** may replicate command data up the chain, until the command data reaches a last node or a final node **506N+1** and at which point exits the network back to master **504**. During a reply phase of the network, the direction of bus communication may move in both directions along the chain. The addressed node **506** may reply to the command by transmitting reply data both up the chain until the command data reaches a last node or a final node **506N+1** and at which point exits the network back to master **504** and also down the chain until the command data reaches initial node **506A** and at which point exits the network back to master **504**. Similar power consumption and bit transmissions occur when controller **112** is operating in fixed MoT mode only commands are initiated at the last node **506N+1** and replies are again received at nodes **506A** and **506N+1**.

[0079] As shown in FIG. 5E, the power consumption for two commands, both moving up the chain in a fixed, MoB mode, causes each of slave nodes 506 to transmit the same quantity of bits and therefore consume approximately the same amount of power. This communication scheme may therefore prevent an overall imbalance in communication related power consumption amongst the blocks of a battery system and lead to a faster charging time as compared to other battery management communication systems. In addition, by sending the command through the entire chain, master node 504 can double check that the chain is accurately receiving its commands and that master node 504 is accurately receiving replies to those commands.

[0080] FIG. 6 is a conceptual diagram illustrating system 600 as an example inter-block communication network of an example battery system configured to balance communication related power consumption of blocks of a battery stack, in accordance with one or more aspects of the present disclosure. System 600 include master node 604 and a plurality of slave nodes 606A-606N+1 (collectively "slave nodes 606"). Master node 604 is analogous to master node 104 of system 100 and slave nodes 606 are each analogous to slave nodes 106 of system 100 except each of slave nodes 606 also includes a respective one of current balancing units 690A-690N+1 (collectively current balancing units 690). System 600 is described below in the context of system 100 of FIG. 1. Although not shown, system 600 may include coupling elements, a battery stack and a controller that are analogous to coupling elements 108, battery stack 120 and controller 112 of system 100. System 600 is described below as being controlled by controller 112 of system 100.

[0081] Controller 112 may operate system 600 as either an alternating MoT and MoB ring-type inter-block communication network or as a fixed, MoT or fixed, MoB, ring-type inter-block communication network described above. System 600 is an enhanced version of systems 400 and 500 in that system 600 also compensates for differences in parasitic capacitances in the transmission lines between nodes in the network.

[0082] For example, as shown in FIG. 6, the length of a transmission line, and therefore the parasitic capacitance associated with the transmission line, between master node 604 and the first slave node 606A and the final slave node 606N+1 is generally greater than the length of transmission lines between each of slave nodes 606. This difference in parasitic capacitance may cause the first slave node 606A and the final slave node 606N+1 to draw more current communicating on the network, and therefore consume a greater amount of power communicating on the network, than each of the other slave nodes 606B-606N in the network.

[0083] To compensate for this variation in power consumption due to differences in parasitic capacitances amongst the transmission lines that are coupling nodes 604 and 606 to the network, some or all of slave nodes 606 may include a respective current balancing unit 690. Each current balancing unit 690 may adjust the power consumed by each of slave nodes 690, so that the slave nodes 606B-606N that would otherwise consume less power, consume approximately the same amount of power as slave nodes 606A and 606N+1. For example, current balancing units 690 may include resistors or other electrical components that increase the current drawn by one of slave nodes 690 to communicate with a different one of slave nodes 690.

[0084] In some examples, although not shown, the first slave node 606A and the final slave node 606N+1 in the network may not include current balancing unit 690. In other examples, current balancing units 690 may be external to slave nodes 606 and instead, included as part of the transmission lines linking slave nodes 606 together. And in other examples, system 600 may forgo the use of current balancing units 690 altogether. Instead, a first type of transmission line may be used by system 600 for linking two slave nodes 606 together that has an inherent parasitic capacitance that matches the inherent parasitic capacitance of a second type of transmission line that is used by system 600 for linking master node 604 to each of the first slave node 606A and the final slave node 606N+1.

[0085] Clause 1. A battery management system comprising: a controller configured to control electrical charging and discharging of a plurality of blocks of a battery; and an inter-block communication network including: a master node and a plurality of slave nodes arranged in a ring-type daisy-chain configuration with the master node; the master node being coupled to the controller and configured to initiate all command messages sent through the inter-block communication network and terminate all reply messages sent through the inter-block communication network; and the plurality of slave nodes being bounded by an initial node coupled to the master node and a last node coupled to the master node.

[0086] Clause 2. The battery management system of clause 1, wherein the controller is configured to control the inter-block communication network by alternating between: a one-way master-on-bottom messaging scheme in which the controller causes the master node to transmit, via the initial node, a command to an addressed node from the plurality of slave nodes and receive, via the last node, a reply from the addressed node; and a one-way master-on-top messaging scheme in which the controller causes the master node to transmit, via the last node, the command to the addressed node and receive, via the initial node, the reply from the addressed node.

[0087] Clause 3. The battery management system of clause 2, wherein the controller is configured to switch between controlling the inter-block communication network using the one-way master-on-top messaging scheme or the one-way master-on-bottom messaging scheme each time the master node receives the reply.

[0088] Clause 4. The battery management system of any of clauses 2-3, wherein: the inter-block communication network is configured to forward the command and the reply from the addressed node through the inter-block communication network and to the last node when the controller is controlling the inter-block communication network in the one-way master-on-bottom messaging scheme; and the inter-block communication network is configured to forward the command and the reply from the addressed node through the inter-block communication network and to the initial node when the controller is controlling the inter-block communication network in the one-way master-on-top messaging scheme.

[0089] Clause 5. The battery management system of any of clause 1, wherein the controller is configured to control the inter-block communication network using either: a one-way master-on-bottom messaging scheme in which the controller causes the master node to: transmit, via the initial node, a command to an addressed node from the plurality of

slave nodes; receive, via the last node, a first reply from the addressed node; and receive, via the initial node, a second reply that is duplicative of the first reply; or a one-way master-on-top messaging scheme in which the controller causes the master node to: transmit, via the last node, the command to the addressed node; receive, via the last node, the first reply from the addressed node; and receive, via the initial node, the second reply that is duplicative of the first reply.

[0090] Clause 6. The battery management system of clause 5, wherein: the inter-block communication network is configured to forward from the addressed node the command and the first and second replies through the inter-block communication network and to the last node when the controller is controlling the inter-block communication network in the one-way master-on-bottom messaging scheme; and the inter-block communication network is configured to forward the command and the first and second replies from the addressed node through the inter-block communication network and to the initial node when the controller is controlling the inter-block communication network in the one-way master-on-top messaging scheme.

[0091] Clause 7. The battery management system of any of clauses 1-6; wherein the inter-block communication network includes a low-side bus and a high-side bus, and wherein the master node and each of the plurality of slave nodes via the low-side bus and the high-side bus.

[0092] Clause 8. The battery management system of any of clauses 1-7, wherein each of the master node and the plurality of slave nodes is coupled to the low-side bus and the high-side bus via a respective resistor-capacitor coupling circuit.

[0093] Clause 9. The battery management system of any of clauses 1-8, wherein each slave node from the plurality of slave nodes is associated with a different respective block from the plurality of blocks.

[0094] Clause 10. The battery management system of clause 8, wherein each slave node from the plurality of slave nodes comprises respective balancing and monitoring circuitry.

[0095] Clause 11. A method comprising: transmitting, by a controller of a battery management system, from a master node of an inter-block communication network and via an initial node from a plurality of slave nodes of the inter-block communication network, a first command to a first addressed node from the plurality of slave nodes; responsive to transmitting the first command, receiving, by the controller, via a last node from the plurality of slave nodes, a first reply from the first addressed node; after receiving the first reply, transmitting, by the controller, from the master node, via the last node; a second command to a second addressed node from the plurality of slave nodes; and receiving, by the controller, via the initial node, a second reply from the second addressed node in response to transmitting the second command.

[0096] Clause 12. The method of clause II, further comprising: receiving, by the controller, via the last node, the first command being forwarded through the inter-block communication network by the first addressed node.

[0097] Clause 13. The method of any of clauses 11-12, fluffier comprising: receiving, by the controller, via the initial node, the second command being forwarded through the inter-block communication network by the second addressed node.

[0098] Clause 14. The method of any of clauses 11-13, wherein the first addressed node is the second addressed node.

[0099] Clause 15. The method of any of clauses 11-14, wherein each slave node from the plurality of slave nodes comprises balancing and monitoring circuitry associated with a different respective block from a plurality of blocks of a battery.

[0100] Clause 16. A method comprising: transmitting, by a controller of a battery management system, from a master node of an inter-block communication network and via an first node from a plurality of slave nodes of the inter-block communication network, a command to a first addressed node from the plurality of slave nodes; responsive to transmitting the command: receiving, by the controller, via a second node from the plurality of slave nodes, a first reply from the first addressed node; and receiving, by the controller, via the first node, a second reply from the first addressed node that is duplicative of the first reply.

[0101] Clause 17. The method of clause 16, wherein the plurality of slave nodes are arranged in a ring-type daisy-chain configuration with the master node, the plurality of slave nodes being bounded by an initial node coupled to the master node and a last node coupled to the master node.

[0102] Clause 18. The method of clause 17, wherein the first node is the initial node and the second node is the last node.

[0103] Clause 19. The method of clause 17, wherein the first node is the last node and the second node is the initial node.

[0104] Clause 20. The method of any of clauses 16-19, wherein each slave node from the plurality of slave nodes is associated with a different respective block from a plurality of blocks of a battery.

[0105] Clause 21. A system comprising means for performing any of the methods of clauses 11-20.

[0106] Clause 22. A computer-readable storage medium comprising instructions, that when executed, causes at least one processor of a controller of a system to perform any of the methods of clauses 11-20.

[0107] In one or more examples, the functions described may be implemented in hardware, software, firmware, or any combination thereof, if implemented in software, the functions may be stored on or transmitted over, as one or more instructions or code, a computer-readable medium and executed by a hardware-based processing unit. Computer-readable media may include computer-readable storage media, which corresponds to a tangible medium such as data storage media, or communication media including any medium that facilitates transfer of a computer program from one place to another, e.g., according to a communication protocol, in this manner, computer-readable media generally may correspond to (1) tangible computer-readable storage media, which is non-transitory or (2) a communication medium such as a signal or carrier wave. Data storage media may be any available media that can be accessed by one or more computers or one or more processors to retrieve instructions, code and/or data structures for implementation of the techniques described in this disclosure. A computer program product may include a computer-readable medium.

[0108] By way of example, and not limitation, such computer-readable storage media can comprise RAM, ROM, EEPROM, CD-ROM or other optical disk storage, magnetic disk storage, or other magnetic storage devices, flash

memory, or any other medium that can be used to store desired program code in the form of instructions or data structures and that can be accessed by a computer. Also, any connection is properly termed a computer-readable medium. For example, if instructions are transmitted from a website, server, or other remote source using a coaxial cable, fiber optic cable, twisted pair, digital subscriber line (DSL), or wireless technologies such as infrared, radio, and microwave, then the coaxial cable, fiber optic cable, twisted pair, DSL, or wireless technologies such as infrared, radio, and microwave are included in the definition of medium. It should be understood, however, that computer-readable storage media and data storage media do not include connections, carrier waves, signals, or other transient media, but are instead directed to non-transient, tangible storage media. Disk and disc, as used herein, includes compact disc (CD), laser disc, optical disc, digital versatile disc (DVD), floppy disk and Blu-ray disc, where disks usually reproduce data magnetically, while discs reproduce data optically with lasers. Combinations of the above should also be included within the scope of computer-readable media.

[0109] Instructions may be executed by one or more processors, such as one or more digital signal processors (DSPs), general purpose microprocessors, application specific integrated circuits (ASICs), field programmable logic arrays (FPGAs), or other equivalent integrated or discrete logic circuitry. Accordingly, the term “processor,” as used herein may refer to any of the foregoing structure or any other structure suitable for implementation of the techniques described herein. In addition, in some aspects, the functionality described herein may be provided within dedicated hardware and/or software modules. Also, the techniques could be fully implemented in one or more circuits or logic elements.

[0110] The techniques of this disclosure may be implemented in a wide variety of devices or apparatuses, including an integrated circuit (IC) or a set of ICs (e.g., a chip set). Various components, modules, or units are described in this disclosure to emphasize functional aspects of devices configured to perform the disclosed techniques, but do not necessarily require realization by different hardware units. Rather, as described above, various units may be combined in a hardware unit or provided by a collection of interoperable hardware units, including one or more processors as described above, in conjunction with suitable software and/or firmware.

What is claimed is:

1. A battery management system comprising:

a controller configured to control electrical charging and discharging of a plurality of blocks of a battery; and
an inter-block communication network including:

a master node and a plurality of slave nodes arranged in a ring-type daisy-chain configuration with the master node;

the master node being coupled to the controller and configured to initiate all command messages sent through the inter-block communication network and terminate all reply messages sent through the inter-block communication network; and

the plurality of slave nodes being bounded by an initial node coupled to the master node and a last node coupled to the master node.

2. The battery management system of claim **1**, wherein the controller is configured to control the inter-block communication network by alternating between:

a one-way master-on-bottom messaging scheme in which the controller causes the master node to transmit, via the initial node, a command to an addressed node from the plurality of slave nodes and receive, via the last node, a reply from the addressed node; and

a one-way master-on-top messaging scheme in which the controller causes the master node to transmit, via the last node, the command to the addressed node and receive, via the initial node, the reply from the addressed node.

3. The battery management system of claim **2**, wherein the controller is configured to switch between controlling the inter-block communication network using the one-way master-on-top messaging scheme or the one-way master-on-bottom messaging scheme each time the master node receives the reply.

4. The battery management system of claim **2**, wherein: the inter-block communication network is configured to forward the command and the reply from the addressed node through the inter-block communication network and to the last node when the controller is controlling the inter-block communication network in the one-way master-on-bottom messaging scheme; and

the inter-block communication network is configured to forward the command and the reply from the addressed node through the inter-block communication network and to the initial node when the controller is controlling the inter-block communication network in the one-way master-on-top messaging scheme.

5. The battery management system of claim **1**, wherein the controller is configured to control the inter-block communication network using either:

a one-way master-on-bottom messaging scheme in which the controller causes the master node to:
transmit, via the initial node, a command to an addressed node from the plurality of slave nodes;
receive, via the last node, a first reply from the addressed node; and
receive, via the initial node, a second reply that is duplicative of the first reply; or

a one-way master-on-top messaging scheme in which the controller causes the master node to:
transmit, via the last node, the command to the addressed node;
receive, via the last node, the first reply from the addressed node; and
receive, via the initial node, the second reply that is duplicative of the first reply.

6. The battery management system of claim **5**, wherein: the inter-block communication network is configured to forward the command and the first and second replies from the addressed node through the inter-block communication network and to the last node when the controller is controlling the inter-block communication network in the one-way master-on-bottom messaging scheme; and

the inter-block communication network is configured to forward the command and the first and second replies from the addressed node through the inter-block communication network and to the initial node when the

controller is controlling the inter-block communication network in the one-way master-on-top messaging scheme.

7. The battery management system of claim **1**, wherein the inter-block communication network includes a low-side bus and a high-side bus, and wherein the master node and each of the plurality of slave nodes via the low-side bus and the high-side bus.

8. The battery management system of claim **1**, wherein each of the master node and the plurality of slave nodes is coupled to the low-side bus and the high-side bus via a respective resistor-capacitor coupling circuit.

9. The battery management system of claim **1**, wherein each slave node from the plurality of slave nodes is associated with a different respective block from the plurality of blocks.

10. The battery management system of claim **8**, wherein each slave node from the plurality of slave nodes comprises respective balancing and monitoring circuitry.

11. A method comprising:

transmitting, by a controller of a battery management system, from a master node of an inter-block communication network and via an initial node from a plurality of slave nodes of the inter-block communication network, a first command to a first addressed node from the plurality of slave nodes;

responsive to transmitting the first command, receiving, by the controller, via a last node from the plurality of slave nodes, a first reply from the first addressed node; after receiving the first reply, transmitting, by the controller, from the master node, via the last node, a second command to a second addressed node from the plurality of slave nodes; and

receiving, by the controller, via the initial node, a second reply from the second addressed node in response to transmitting the second command.

12. The method of claim **11**, further comprising:

receiving, by the controller, via the last node, the first command being forwarded through the inter-block communication network by the first addressed node.

13. The method of claim **11**, further comprising:

receiving, by the controller, via the initial node, the second command being forwarded through the inter-block communication network by the second addressed node.

14. The method of claim **11**, wherein the first addressed node is the second addressed node.

15. The battery management system of claim **1**, wherein each slave node from the plurality of slave nodes comprises balancing and monitoring circuitry associated with a different respective block from a plurality of blocks of a battery.

16. A method comprising:

transmitting, by a controller of a battery management system, from a master node of an inter-block communication network and via an first node from a plurality of slave nodes of the inter-block communication network, a command to a first addressed node from the plurality of slave nodes;

responsive to transmitting the command:

receiving, by the controller, via a second node from the plurality of slave nodes, a first reply from the first addressed node; and

receiving, by the controller, via the first node, a second reply from the first addressed node that is duplicative of the first reply.

17. The method of claim **16**, wherein the plurality of slave nodes are arranged in a ring-type daisy-chain configuration with the master node, the plurality of slave nodes being bounded by an initial node coupled to the master node and a last node coupled to the master node.

18. The method of claim **17**, wherein the first node is the initial node and the second node is the last node.

19. The method of claim **17**, wherein the first node is the node and the second node is the initial node.

20. The method of claim **16**, wherein each slave node from the plurality of slave nodes is associated with a different respective block from a plurality of blocks of a battery.

* * * * *