

(12) INTERNATIONAL APPLICATION PUBLISHED UNDER THE PATENT COOPERATION TREATY (PCT)

(19) World Intellectual Property

Organization

International Bureau

(43) International Publication Date

03 December 2020 (03.12.2020)



(10) International Publication Number

WO 2020/243069 A1

(51) International Patent Classification:

C08J 7/04 (2020.01) C08J 7/12 (2006.01)

C08J 7/06 (2006.01) C08J 7/14 (2006.01)

TR), OAPI (BF, BJ, CF, CG, CI, CM, GA, GN, GQ, GW, KM, ML, MR, NE, SN, TD, TG).

(21) International Application Number:

PCT/US2020/034504

Published:

- with international search report (Art. 21(3))
- before the expiration of the time limit for amending the claims and to be republished in the event of receipt of amendments (Rule 48.2(h))

(22) International Filing Date:

26 May 2020 (26.05.2020)

(25) Filing Language:

English

(26) Publication Language:

English

(30) Priority Data:

16/423,838 28 May 2019 (28.05.2019) US

(71) Applicant: **BOSE CORPORATION** [US/US]; The Mountain Road, MS3B1, Framingham, MA 01701 (US).

(72) Inventors: **GAO, Kai**; Bose Corporation, The Mountain Road, MS3B1, Framingham, MA 01701 (US). **PREVOIR, Shawn**; Bose Corporation, The Mountain Road, MS3B1, Framingham, MA 01701 (US). **IRWIN, Alexander**; Bose Corporation, The Mountain Road, MS3B1, Framingham, MA 01701 (US).

(74) Agent: **ANDREASEN, David, S**; Bose Corporation, The Mountain Road, MS3B1, Framingham, MA 01701 (US).

(81) Designated States (unless otherwise indicated, for every kind of national protection available): AE, AG, AL, AM, AO, AT, AU, AZ, BA, BB, BG, BH, BN, BR, BW, BY, BZ, CA, CH, CL, CN, CO, CR, CU, CZ, DE, DJ, DK, DM, DO, DZ, EC, EE, EG, ES, FI, GB, GD, GE, GH, GM, GT, HN, HR, HU, ID, IL, IN, IR, IS, JO, JP, KE, KG, KH, KN, KP, KR, KW, KZ, LA, LC, LK, LR, LS, LU, LY, MA, MD, ME, MG, MK, MN, MW, MX, MY, MZ, NA, NG, NI, NO, NZ, OM, PA, PE, PG, PH, PL, PT, QA, RO, RS, RU, RW, SA, SC, SD, SE, SG, SK, SL, ST, SV, SY, TH, TJ, TM, TN, TR, TT, TZ, UA, UG, US, UZ, VC, VN, WS, ZA, ZM, ZW.

(84) Designated States (unless otherwise indicated, for every kind of regional protection available): ARIPO (BW, GH, GM, KE, LR, LS, MW, MZ, NA, RW, SD, SL, ST, SZ, TZ, UG, ZM, ZW), Eurasian (AM, AZ, BY, KG, KZ, RU, TJ, TM), European (AL, AT, BE, BG, CH, CY, CZ, DE, DK, EE, ES, FI, FR, GB, GR, HR, HU, IE, IS, IT, LT, LU, LV, MC, MK, MT, NL, NO, PL, PT, RO, RS, SE, SI, SK, SM,

(54) Title: SURFACE TREATMENTS FOR SILICONE ACOUSTIC DIAPHRAGMS

(57) Abstract: A method of treating a silicone component for an electro-acoustic driver, the method including: forming a body of an elastomeric material having a polymeric backbone, where a portion of the polymeric backbone includes alternating silicon and oxygen atoms without carbon atoms, the body having a front surface and a back surface where the front surface and the back surface have a first level of surface tack; and forming an outermost layer on or within at least one part of the front surface or the back surface, the outermost layer having a second level of surface tack that is less than the first level of surface tack. The outermost layer includes a permanent silicone coating applied on the front or back surface or an altered surface chemistry within the front or back surface generated using ultraviolet/ozone treatment.



WO 2020/243069 A1

SURFACE TREATMENTS FOR SILICONE ACOUSTIC DIAPHRAGMS

Background

[0001] This disclosure relates to surface treatments for silicone acoustic diaphragms to reduce surface tack and debris accumulation.

[0002] Components that are made of soft materials, such as rubber, can have a tacky surface that can disrupt manufacturing processes and/or affect the functionality of these components. For example, electro-acoustic drivers (*e.g.*, microspeakers that can be used in miniature earbuds) have a compliant diaphragm made of very soft liquid silicone rubber (LSR) to achieve the desired acoustic performance. During assembly, the tacky surface of the diaphragm made of liquid silicone rubber can collect dust or dirt from the air, and the collected dust or dirt can alter the acoustic property of the component and/or affect the aesthetics of the component. Additionally, the tacky surface of the diaphragm may stick to parts and fixtures during assembly underneath and in operation, *i.e.*, a bobbin, and tear if not released carefully.

[0003] Conventional methods for reducing surface tack involve application of one or more anti-sticking powders. However, such powders can cause dusting which is problematic.

[0004] Accordingly, there is a need in the art for inexpensive, efficient, and effective methods for treating surfaces of silicone components to reduce surface tack with minimal impact on acoustic performance and without producing any mess.

Summary

[0005] All examples and features mentioned below can be combined in any technically possible way.

[0006] In one aspect, a method of treating a silicone component for an electro-acoustic driver is provided. The method includes forming a body of an elastomeric material having a polymeric backbone, where a portion of the polymeric backbone includes alternating silicon and oxygen atoms without carbon atoms, the body having a front surface and a back surface where the front surface and the back surface have a first level of surface tack. The method further includes forming an outermost layer on or within at least one part of the front surface or the back surface, the outermost layer having a second level of surface tack that is less than the first level of surface tack.

[0007] Implementations may include one or more of the following. The step of forming the outermost layer can include oxidizing at least one part of the front surface or the back

surface to incorporate at least one functional group on the polymeric backbone of the elastomeric material. The at least one functional group can consist of a hydroxyl diol, a carboxylic acid, a ketone, and/or an aldehyde on the polymeric backbone. In another implementation, the step of forming the outermost layer comprises generating SiO₂ on or within at least one part of the front surface or the back surface.

[0008] The step of forming the outermost layer can include generating surface oxidation using ultraviolet/ozone treatment. The ultraviolet/ozone treatment can include an ultraviolet light source emitting energy at two different wavelengths.

[0009] In some implementations, the step of forming the outermost layer includes altering the surface chemistry of the outermost layer within the front surface or the back surface. In other implementations, the step of forming the outermost layer includes forming a permanent coating of silicone on top of the body.

[0010] In another aspect, a diaphragm for an electro-acoustic driver is provided where a body of an elastomeric material having a polymeric backbone is included. A portion of the polymeric backbone includes alternating silicon and oxygen atoms without carbon atoms. The body has a front surface and a back surface where the front surface and the back surface have a first level of surface tack. An outermost layer on or within at least one part of the front surface or the back surface has a second level of surface tack that is less than the first level of surface tack.

[0011] Implementations may include one or more of the following. The outermost layer can include a permanent coating made of silicone on top of the body. The permanent coating can be uniformly distributed on the front surface and the back surface. The outermost layer can include a top-most layer within the front surface or the back surface. The outermost layer can include at least one functional group incorporated on the polymeric backbone via surface oxidation. The surface oxidation can be generated using ultraviolet/ozone treatment. The at least one functional group can consist of a hydroxyl diol, a carboxylic acid, a ketone, and/or an aldehyde on the polymeric backbone. The outermost layer can comprise SiO₂ on or within at least one part of the front surface or the back surface.

[0012] In a further aspect, an electro-acoustic driver is provided. The electro-acoustic driver includes a housing having an opening at both ends; a bobbin arranged within the housing, the bobbin having an opening at both ends; and a diaphragm secured to the bobbin and the housing, the diaphragm formed of an elastomeric material having a polymeric backbone. A portion of the polymeric backbone includes alternating silicon and oxygen atoms without carbon atoms, and the diaphragm includes a front surface and a back surface

having a first level of surface tack. An outermost layer on or within at least one part of the front surface or the back surface has a second level of surface tack that is less than the first level of surface tack.

[0013] Implementations may include one or more of the following. The outermost layer can include a permanent coating made of silicone on top of the front surface or the back surface. The outermost layer can include a top-most layer within the front surface or the back surface. The outermost layer can include at least one functional group incorporated on the polymeric backbone via surface oxidation or SiO₂.

[0014] Other features and advantages will be apparent from the description and the claims.

Brief Description of the Drawings

[0015] FIG. 1A is an example perspective view of an electro-acoustic driver.

[0016] FIG. 1B is an example cutaway view of an electro-acoustic driver.

[0017] FIG. 1C is an example partially exploded cutaway view of the electro-acoustic driver of FIG. 1B.

[0018] FIG. 2 is an example perspective view of the diaphragm of FIGS. 1A to 1C.

[0019] FIG. 3 is a flowchart of an example method of treating a silicone component of an electro-acoustic driver to reduce surface tack.

[0020] FIG. 4 is a schematic representation of a diaphragm of an electro-acoustic driver including a permanent coating.

[0021] FIG. 5 is a schematic representation of a diaphragm of an electro-acoustic driver including surface oxidation.

Detailed Description

[0022] While silicone components are commonly used for wearable devices because they are biocompatible, soft and resilient, such components tend to have a high coefficient of friction, which causes them to collect dust or dirt or stick to itself or other components. The rubber diaphragm can also stick to other components (*e.g.*, a bobbin) within the driver and tear easily. Dusting agents, such as talc, mica, clay and calcium carbonate, have been used historically to prevent rubbers from sticking together. Metallic stearates have also been used as anti-tack materials historically. Unfortunately, these anti-tack materials cause dusting, snowing, and foaming, which are hazardous and messy. The surface treatments described herein reduce the surface tack of materials made of silicone while avoiding the hazards and mess associated with conventional anti-tack materials. The surface treatments described

herein also reduce the surface tack without significantly impacting the acoustic properties of the material.

[0023] The embodiments and implementations disclosed or otherwise envisioned herein can be utilized with any modern in-ear headphones, or earbuds, including microspeakers having an elastomeric component made of silicone, for example. However, the disclosure is not limited to these enumerated devices, and thus the disclosure and embodiments disclosed herein can encompass any device including one or more silicone components.

[0024] Referring to FIGS. 1A, 1B, and 1C, an example electro-acoustic driver 10 (*e.g.*, a microspeaker) that can be used in a miniature earbud is shown. The electro-acoustic driver 10 includes a housing 12 that can be cylindrical and include an opening at both ends. A bobbin 14 can be included inside the housing 12 and the bobbin 14 can be cylindrical in shape and include an opening at both ends. The housing 12 can be made of stainless steel and the bobbin 14 can be made of a polyimide (*e.g.*, KAPTON[®]) or polyethylene terephthalate (PET) (*e.g.*, MYLAR[®]). The housing 12 and bobbin 14 can be secured at one of their open ends to a diaphragm, or membrane, 16 formed of a compliant material, such as, an elastomer. The electro-acoustic driver 10 can also include a coil assembly 18 wound onto an outside surface of the bobbin 14. The coil assembly 18 can include a winding of an electrical conductor. The electro-acoustic driver 10 can also include a magnet assembly 20 secured to a platform at an end of the housing 12 that is opposite to the diaphragm 16. The magnet assembly 20 can include magnet pieces 20A and 20B that can be, for example, neodymium magnets, and an intervening coin 20C. The magnet assembly 20 extends along a housing axis 24 (*i.e.*, a cylinder axis) and into an open region inside the bobbin 14. The axis of the bobbin 14 can be substantially co-axial with the housing axis 24. The outer diameter of the housing 12 can be approximately less than 8 mm, and in some embodiments, approximately between 3.0 mm and 4.5 mm. The diameter of the diaphragm ϕ_D can be approximately less than 4.7 mm. The magnet pieces 20A, 20B, and 20C can have a diameter ϕ_M that is approximately between 1.5 mm and 4.5 mm. The radiating area is approximately equal to the area of an inner region of the diaphragm 16.

[0025] The compliant material used to form the diaphragm 16 is generally tacky and has a high coefficient of friction, which can cause the diaphragm 16 to collect dust or dirt from the air during assembly. Such debris can alter the acoustic properties of the diaphragm when in use. The tackiness of the diaphragm 16 may also cause the diaphragm to stick to the bobbin 14 and tear if not released carefully. With reference to FIG. 2, the diaphragm 16 can be formed of a liquid silicone rubber that can be cured to provide the desired thickness t , which

can be approximately a few tens of microns to more than 100 μm . The diaphragm 16 includes a front surface 32, a back surface 34, and an inner region within the dashed circular line 36 of radius R_i that is approximately equal to the outer diameter of the bobbin 14. The outer radius R_o is approximately equal to the outer diameter of the housing 12.

[0026] When assembled and in use, the bobbin 14 moves substantially along its axis and the housing axis 24 in response to an electrical current conducted through the winding of the coil assembly 18. This motion causes the inner region of the diaphragm 16 to move axially and displace air to thereby generate an acoustic signal. The diaphragm 16 has a substantially planar shape when at rest, that is, when no electrical signal is applied to the winding of the coil assembly 18 to generate sound. When the microspeaker 10 is driven by an electrical signal to cause a motion of the bobbin 14 along the housing axis 24, the compliant nature of the diaphragm 16 results in its deformation.

[0027] Although the diaphragm 16 can be made of any suitable compliant material, one suitable material is liquid silicone rubber (*e.g.*, ELASTOSIL[®] LR 3070/OO-20 A/B material available from Wacker Chemie AG of Munich, Germany). Generally, any suitable polymeric organosilicon compound or silicone, also known as Poly(dimethyl)siloxane (PDMS), is suitable. The ELASTOSIL liquid silicone rubber has a hardness of around 20 Shore OO durometer, for example and exhibits the desired acoustic performance for the electro-acoustic driver 10.

[0028] One technique for fabricating the diaphragm 16 includes placing an open end of the housing 12 and an open end of the bobbin 14 into a single thin layer of liquid silicone. The liquid silicone is then cured to form the diaphragm 16. The central region of the diaphragm 16 can be stiffened while the annular region that surrounds the central region remains compliant. The methods described herein focus on altering surface chemistries occurring on the outer sub-micron level of the material to lower the coefficient of friction without impacting the bulk properties. The methods described herein also focus on applying a very thin coating to the surface of the material to lower the coefficient of friction without significantly impacting the acoustic performance of the material.

[0029] FIG. 3 is a flowchart representation of an example method 100 of treating a silicone component for an electro-acoustic driver. According to the method, at step S100 a diaphragm 16 is formed where the diaphragm is made of an elastomeric material having a polymeric backbone. The diaphragm can be formed by creating one or more elastomeric layers 22 (as shown in FIGS. 4 and 5), which are at least partially cured. The term “partially cured” means that a skin coat is formed on top of an elastomeric layer to a degree that the

elastomeric material in that layer will not flow or mix with a new layer of liquid elastomeric material deposited on the partially cured layer. The elastomeric material can be a liquid silicone rubber (*e.g.*, ELASTOSIL[®] LR 3070/00-20) which includes a polymeric backbone that includes alternating silicon and oxygen atoms without carbon atoms. The formation of the diaphragm 16 can also include curing the liquid silicone rubber using a platinum catalyst in a 150° C. environment for approximately 45 minutes. Optionally, the step of creating one or more elastomeric layers can be repeated to form a multi-layer membrane by depositing one or more additional layers of a liquid elastomeric material and then partially or fully curing each of these layers before applying an additional layer.

[0030] The diaphragm 16 includes a front surface 32 and a back surface 34 having a first coefficient of friction. As described herein, the material used to form diaphragm 16 is selected based on the desired acoustic properties for the electro-acoustic driver. However, such materials tend to have a high coefficient of friction. Accordingly, front surface 32 and back surface 34 have a first high coefficient of friction.

[0031] To lower the coefficient of friction of front surface 32 and/or back surface 34, the method continues at step S110 by forming an outermost layer 36 on or within at least a part of the front surface 32 and/or the back surface 34. As shown in FIG. 4, an outermost layer 36 can be formed as a permanent coating on top of front surface 32 and/or back surface 34. By using an appropriate silicone, this coating can be bonded to the substrate permanently. For example, silicone coatings can bond with silicone substrates due to their compatibility in chemistry. The coatings can be applied with the aid of thin solvents during the standard spraying or dipping process. Example suitable coatings include, but are not limited to, Product Name X-93-1710-1 available from Shin-Etsu Silicones of America, Inc. of Akron, OH and Product Name HCD-25371 available from Momentive Performance Materials Inc. of Waterford, NY.

[0032] The outermost layer 36 can be formed on back surface 34 with or without front surface 32 depending on the application. Similarly, the outermost layer 36 can be formed on front surface 32 with or without back surface 34 depending on the application. Although FIG. 4 shows the outermost layer 36 formed uniformly on top of front surface 32, the outermost layer 36 can be formed on any part of front surface 32 and/or back surface 34 and does not necessarily include the entirety of either surface.

[0033] As shown in FIG. 5, an outermost layer 36 can also be formed within the outermost nanometer layers (<20 nm) of the front surface 32 and the back surface 34. In other words, the outermost layer 36 can be integral within the front surface 32 and the back surface

34 as opposed to resting on top of the surfaces as shown in FIG. 4. For example, the outermost layer 36 can be generated using ultraviolet/ozone (UV/O) treatment, which creates surface oxidation within front surface 32 and back surface 34. The surface oxidation that is created with UV/O treatment can also be accompanied by the generation of SiO₂ on or within the surface of the front surface 32 and/or the back surface 34. The UV/O treatment can be conducted in any suitable gas chamber including oxygen. Generally, such chambers include UV lamp stations that emit multiple wavelengths. Such chambers can be filled with atmospheric air or oxygen. For example, the atmospheric oxygen in such chambers can be irradiated with UV rays having a wavelength of 184.9 nm to form ozone (O₃). Ozone decomposes through irradiation with UV rays having a wavelength of 253.7 nm. Atomic oxygen is generated during these processes. Although the embodiments and implementations disclosed or otherwise envisioned herein include UV lamps, any suitable source of light may be employed, such as, mercury lights, electric arcs, sunlight, lasers tuned to a suitable wavelength, flash tubes, etc., instead.

[0034] To achieve a reduced tackiness, the electro-acoustic drivers or diaphragms 16 can be exposed to the UV/O treatment for at least 4 minutes, and preferably at least 5-10 minutes at ambient temperature. Prolonged treating time and elevated temperature show increased surface chemistry change. Effective surface oxidation using the UV/O treatment is observed at 50 degrees Celsius, and even further surface oxidation is observed at 100 and 150 degrees Celsius. There is minimal impact on the surface chemistry from using different oxygen flow rates.

[0035] Advantageously, the UV/O treatment alters the surface chemistry of the top-most nanometer layer (<20 nm) of the front surface 32 and/or the back surface 34 without changing the overall acoustic property of the diaphragm 16.

[0036] Other implementations are within the scope of the following claims and other claims to which the applicant may be entitled.

Claims

What is claimed is:

1. A method of treating a silicone component for an electro-acoustic driver, the method comprising:
forming a body comprising an elastomeric material having a polymeric backbone, wherein a portion of the polymeric backbone includes alternating silicon and oxygen atoms without carbon atoms, the body having a front surface and a back surface where the front surface and the back surface have a first level of surface tack; and
forming an outermost layer on or within at least one part of the front surface or the back surface, the outermost layer having a second level of surface tack that is less than the first level of surface tack.
2. The method of claim 1, wherein the step of forming the outermost layer comprises oxidizing at least one part of the front surface or the back surface to incorporate at least one functional group on the polymeric backbone of the elastomeric material.
3. The method of claim 2, wherein the at least one functional group consists of a hydroxyl diol, a carboxylic acid, a ketone, and/or an aldehyde on the polymeric backbone.
4. The method of claim 1, wherein the step of forming the outermost layer comprises generating SiO₂ on or within at least one part of the front surface or the back surface.
5. The method of claim 1, wherein the step of forming the outermost layer comprises generating surface oxidation using ultraviolet/ozone treatment.
6. The method of claim 5, wherein the ultraviolet/ozone treatment comprises an ultraviolet light source emitting energy at two different wavelengths.
7. The method of claim 1, wherein the step of forming the outermost layer comprises forming a permanent coating comprising silicone on top of the body.
8. The method of claim 1, wherein the step of forming the outermost layer comprises altering the surface chemistry of the outermost layer within the front surface or the back surface.

9. A diaphragm for an electro-acoustic driver, comprising:
 - a body comprising an elastomeric material having a polymeric backbone, wherein a portion of the polymeric backbone includes alternating silicon and oxygen atoms without carbon atoms, the body having a front surface and a back surface where the front surface and the back surface have a first level of surface tack; and
 - an outermost layer on or within at least one part of the front surface or the back surface, the outermost layer having a second level of surface tack that is less than the first level of surface tack.
10. The diaphragm of claim 9, wherein the outermost layer comprises a permanent coating made of silicone on top of the body.
11. The diaphragm of claim 10, wherein the permanent coating is uniformly distributed on the front surface and the back surface.
12. The diaphragm of claim 9, wherein the outermost layer comprises a top-most layer within the front surface or the back surface.
13. The diaphragm of claim 9, wherein the outermost layer comprises at least one functional group incorporated on the polymeric backbone via surface oxidation.
14. The diaphragm of claim 13, wherein the at least one functional group consists of a hydroxyl diol, a carboxylic acid, a ketone, and/or an aldehyde on the polymeric backbone.
15. The diaphragm of claim 13, wherein the outermost layer comprises SiO₂ on or within at least one part of the front surface or the back surface.
16. The diaphragm of claim 13, wherein the surface oxidation is generated using ultraviolet/ozone treatment.
17. An electro-acoustic driver, comprising:
 - a housing having an opening at both ends;
 - a bobbin arranged within the housing, the bobbin having an opening at both ends;

a diaphragm secured to the bobbin and the housing, the diaphragm formed of an elastomeric material having a polymeric backbone, wherein a portion of the polymeric backbone includes alternating silicon and oxygen atoms without carbon atoms, and wherein the diaphragm comprises a front surface and a back surface having a first level of surface tack; and

an outermost layer on or within at least one part of the front surface or the back surface, the outermost layer having a second level of surface tack that is less than the first level of surface tack.

18. The electro-acoustic driver of claim 17, wherein the outermost layer comprises a permanent coating made of silicone on top of the front surface or the back surface.

19. The electro-acoustic driver of claim 17, wherein the outermost layer comprises a top-most layer within the front surface or the back surface.

20. The electro-acoustic driver of claim 19, wherein the outermost layer comprises at least one functional group incorporated on the polymeric backbone via surface oxidation or SiO₂.

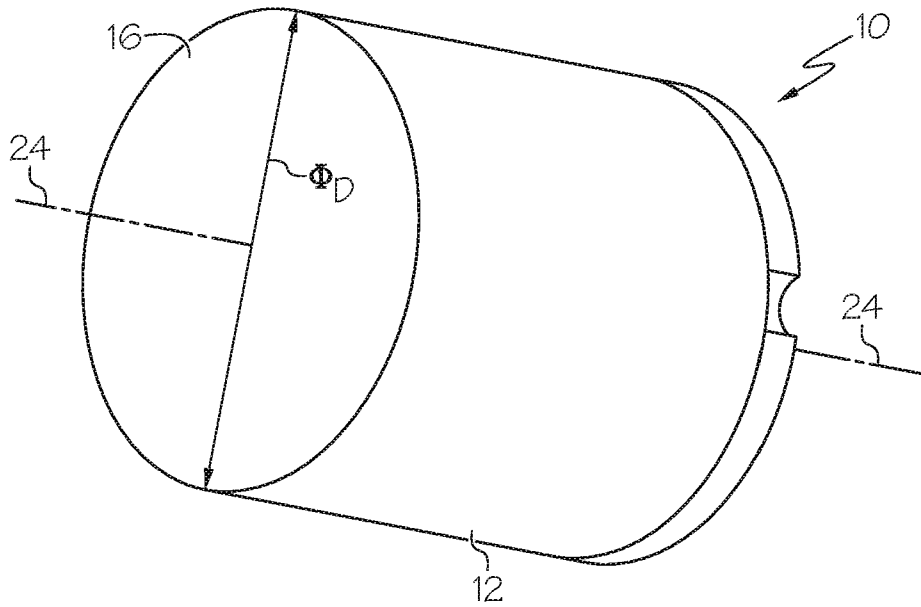

Fig. 1A

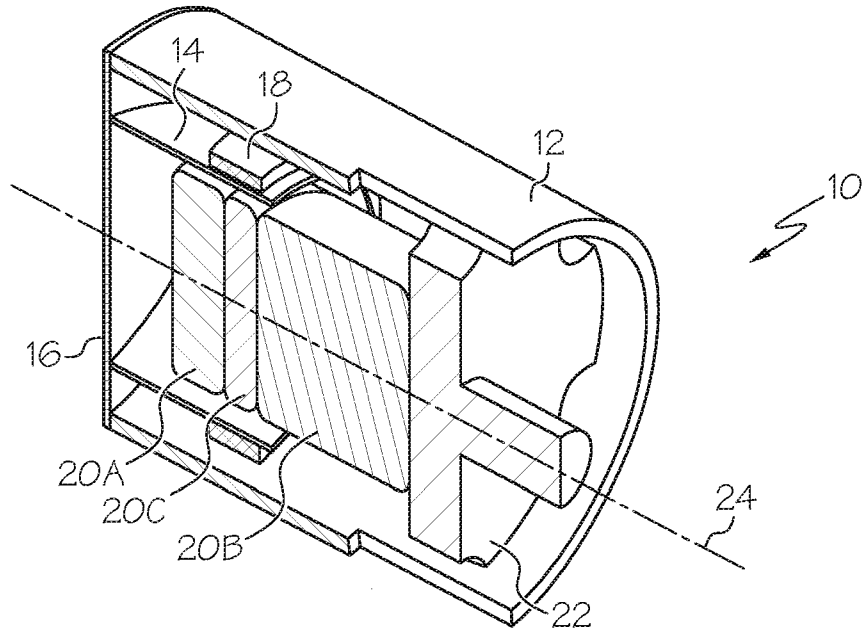

Fig. 1B

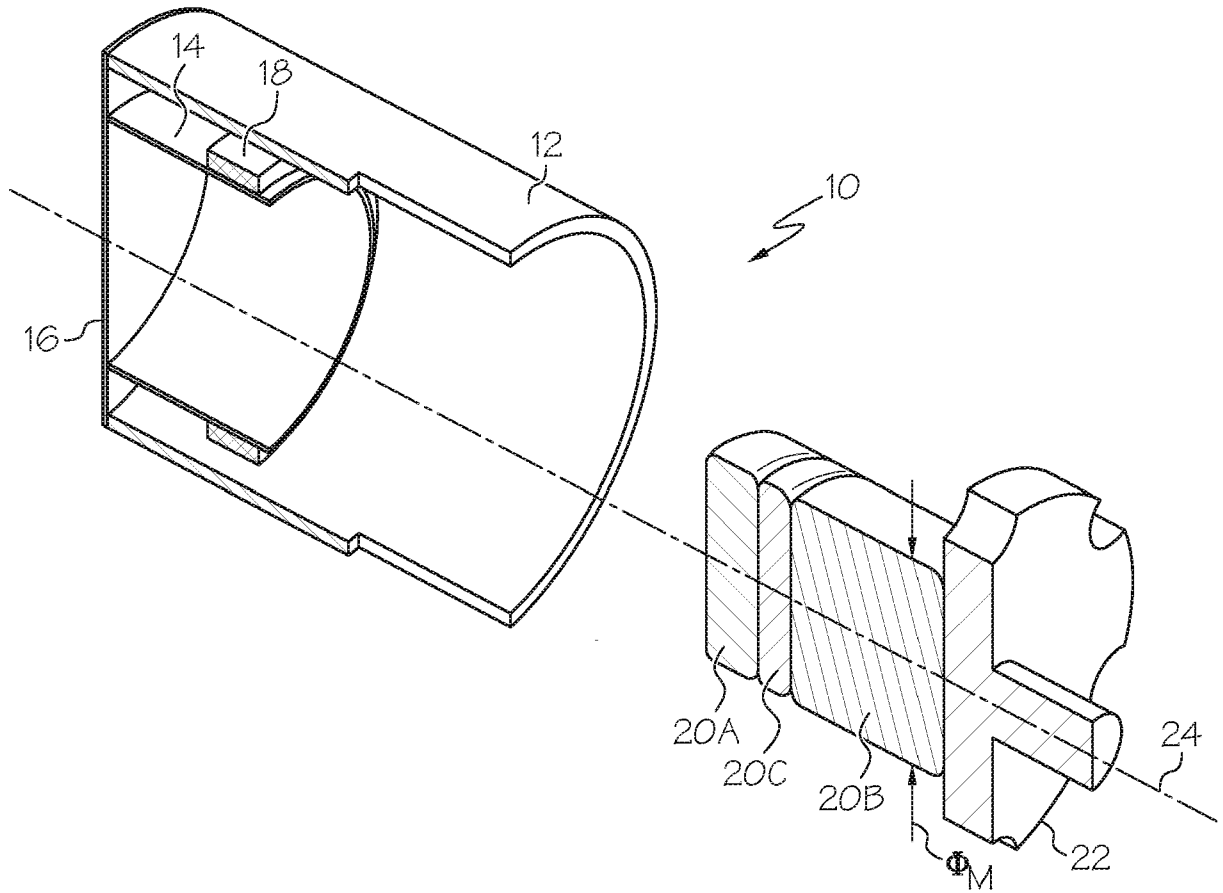

Fig. 1C

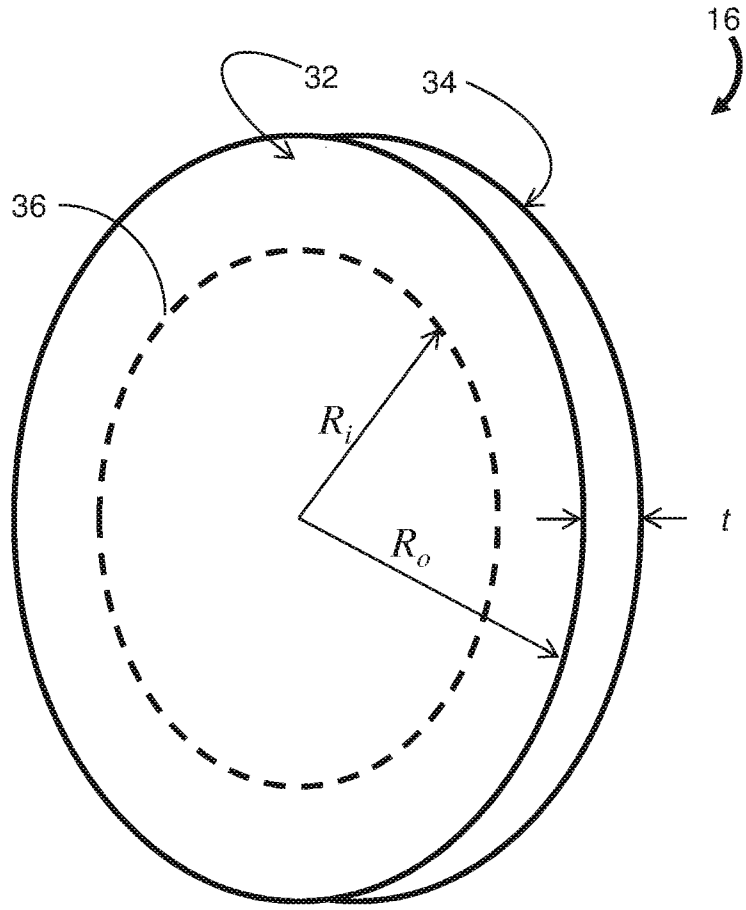

Fig. 2

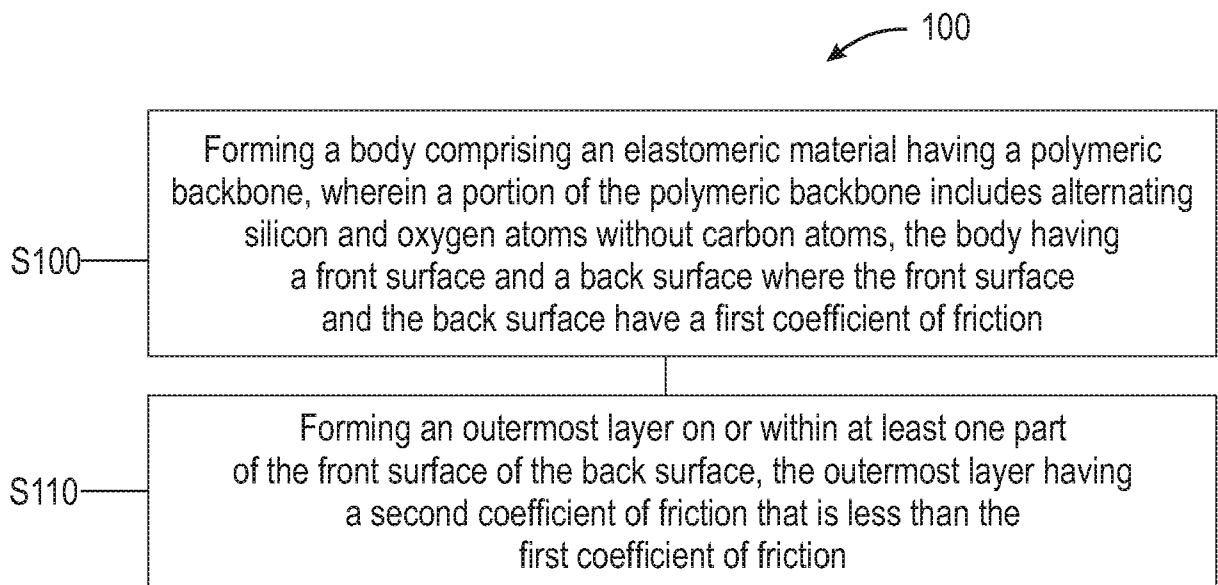

Fig. 3

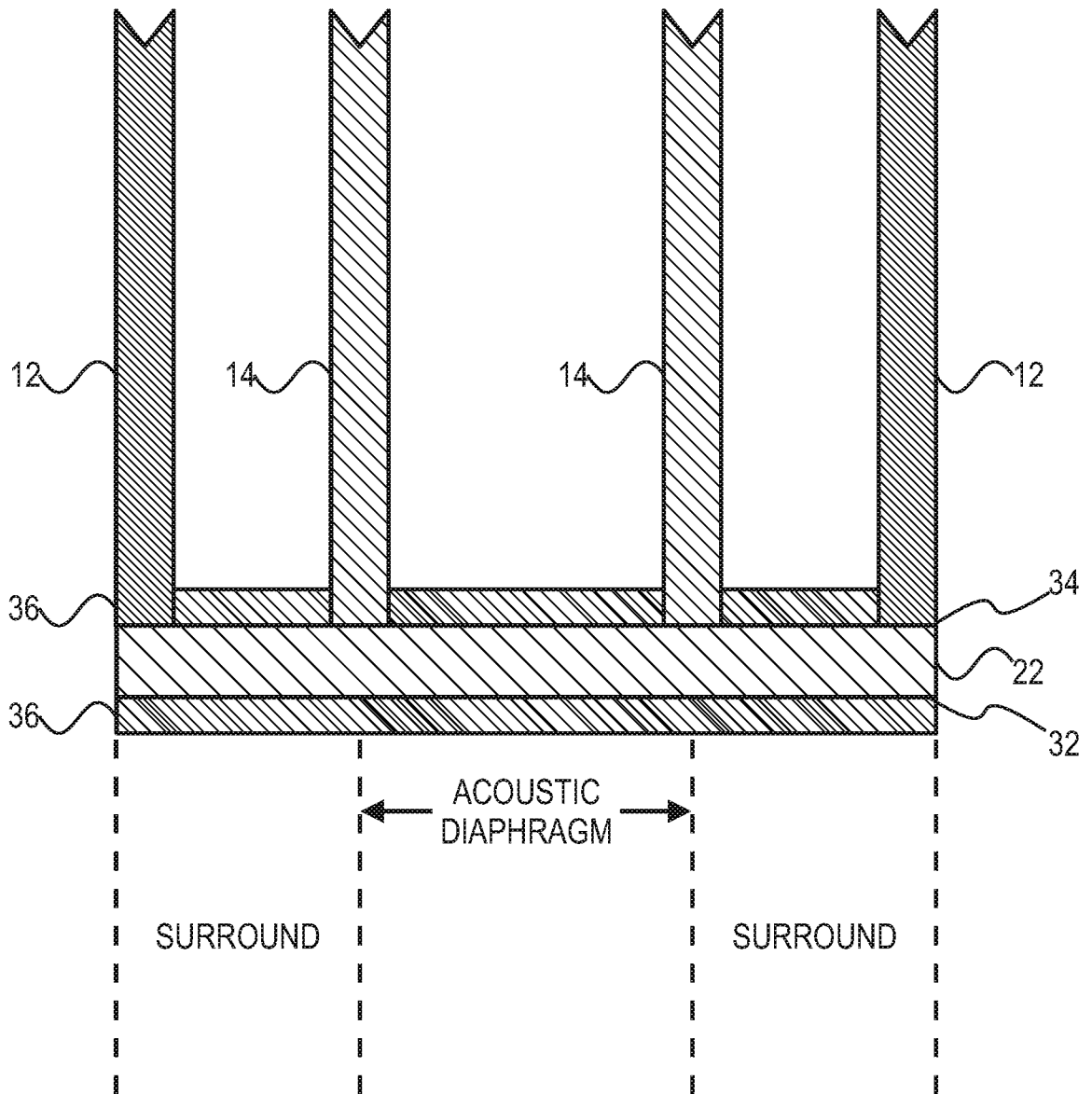

Fig. 4

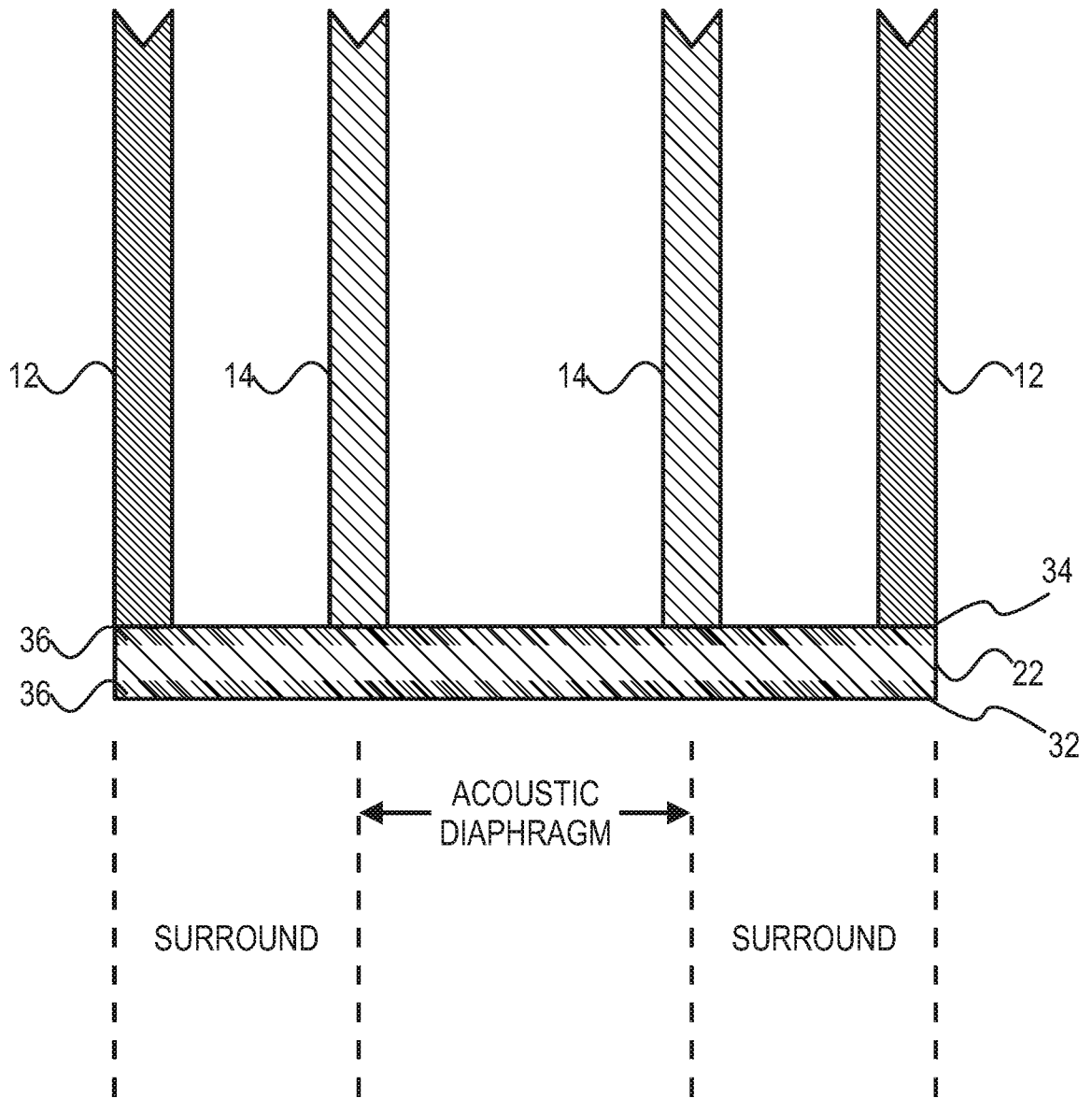

Fig. 5

INTERNATIONAL SEARCH REPORT

International application No
PCT/US2020/034504

A. CLASSIFICATION OF SUBJECT MATTER
 INV. C08J7/04 C08J7/06 C08J7/12 C08J7/14
 ADD.
 According to International Patent Classification (IPC) or to both national classification and IPC

B. FIELDS SEARCHED
 Minimum documentation searched (classification system followed by classification symbols)
 C08J
 Documentation searched other than minimum documentation to the extent that such documents are included in the fields searched

Electronic data base consulted during the international search (name of data base and, where practicable, search terms used)
 EPO-Internal

C. DOCUMENTS CONSIDERED TO BE RELEVANT

Category*	Citation of document, with indication, where appropriate, of the relevant passages	Relevant to claim No.
X A	WO 2016/030183 A1 (FRAUNHOFER GES ZUR FÖRDERUNG DER ANGEWANDTEN FORSCHUNG E V [DE]) 3 March 2016 (2016-03-03) page 1, lines 7-11; claims 1,3-5,9,111 page 1, line 15 - page 2, line 2 page 5, lines 4-11 page 6, lines 15-19 page 7, lines 9-17 page 12, lines 13-25 page 19, lines 12-15	1-3,5,6, 8,9, 12-14,16 17,19,20
X	----- WO 2016/166227 A1 (DOW CORNING [US]; WOLF HANS PETER [DE]; BACKER MICHAEL [DE]) 20 October 2016 (2016-10-20) paragraphs [0001], [0053] - [0056]; claims 1-5,14-17 ----- -/--	1,8,9,12

Further documents are listed in the continuation of Box C.

See patent family annex.

* Special categories of cited documents :

- "A" document defining the general state of the art which is not considered to be of particular relevance
- "E" earlier application or patent but published on or after the international filing date
- "L" document which may throw doubts on priority claim(s) or which is cited to establish the publication date of another citation or other special reason (as specified)
- "O" document referring to an oral disclosure, use, exhibition or other means
- "P" document published prior to the international filing date but later than the priority date claimed

- "T" later document published after the international filing date or priority date and not in conflict with the application but cited to understand the principle or theory underlying the invention
- "X" document of particular relevance; the claimed invention cannot be considered novel or cannot be considered to involve an inventive step when the document is taken alone
- "Y" document of particular relevance; the claimed invention cannot be considered to involve an inventive step when the document is combined with one or more other such documents, such combination being obvious to a person skilled in the art
- "&" document member of the same patent family

Date of the actual completion of the international search 25 August 2020	Date of mailing of the international search report 02/11/2020
Name and mailing address of the ISA/ European Patent Office, P.B. 5818 Patentlaan 2 NL - 2280 HV Rijswijk Tel. (+31-70) 340-2040, Fax: (+31-70) 340-3016	Authorized officer Pamies Olle, Silvia

INTERNATIONAL SEARCH REPORT

International application No
PCT/US2020/034504

C(Continuation). DOCUMENTS CONSIDERED TO BE RELEVANT		
Category*	Citation of document, with indication, where appropriate, of the relevant passages	Relevant to claim No.
X	WO 2018/007372 A1 (ISOVOLTA [AT]) 11 January 2018 (2018-01-11)	1,9
Y	page 1, paragraph 1; claims 1,10,13-15 page 5, paragraph 3 page 6, paragraph 6 page 8, last paragraph page 9, paragraph 1 -----	17,19
Y	US 2017/359657 A1 (BUSHKO WIT [US] ET AL) 14 December 2017 (2017-12-14) paragraphs [0001], [0004], [0012] - [0018], [0032], [0038]; claims 1,2,7,8,12-19 -----	17,19

INTERNATIONAL SEARCH REPORT

International application No.
PCT/US2020/034504

Box No. II Observations where certain claims were found unsearchable (Continuation of item 2 of first sheet)

This international search report has not been established in respect of certain claims under Article 17(2)(a) for the following reasons:

1. Claims Nos.:
because they relate to subject matter not required to be searched by this Authority, namely:

2. Claims Nos.:
because they relate to parts of the international application that do not comply with the prescribed requirements to such an extent that no meaningful international search can be carried out, specifically:

3. Claims Nos.:
because they are dependent claims and are not drafted in accordance with the second and third sentences of Rule 6.4(a).

Box No. III Observations where unity of invention is lacking (Continuation of item 3 of first sheet)

This International Searching Authority found multiple inventions in this international application, as follows:

see additional sheet

1. As all required additional search fees were timely paid by the applicant, this international search report covers all searchable claims.

2. As all searchable claims could be searched without effort justifying an additional fees, this Authority did not invite payment of additional fees.

3. As only some of the required additional search fees were timely paid by the applicant, this international search report covers only those claims for which fees were paid, specifically claims Nos.:

4. No required additional search fees were timely paid by the applicant. Consequently, this international search report is restricted to the invention first mentioned in the claims; it is covered by claims Nos.:
2, 3, 5, 6, 13, 14, 16(completely); 1, 8, 9, 12, 17, 19, 20(partially)

Remark on Protest

- The additional search fees were accompanied by the applicant's protest and, where applicable, the payment of a protest fee.
- The additional search fees were accompanied by the applicant's protest but the applicable protest fee was not paid within the time limit specified in the invitation.
- No protest accompanied the payment of additional search fees.

FURTHER INFORMATION CONTINUED FROM PCT/ISA/ 210

This International Searching Authority found multiple (groups of) inventions in this international application, as follows:

1. claims: 2, 3, 5, 6, 13, 14, 16(completely); 1, 8, 9, 12, 17, 19, 20(partially)

method for treating a silicone component, diaphragm and electro-acoustic driver, wherein the lower tackiness is obtained by oxidizing at least one part of the surface to incorporate at least one functional group on the silicone elastomer or by treating with UV/ozone

2. claims: 4, 15(completely); 1, 8, 9, 12, 17, 19, 20(partially)

method for treating a silicone component, diaphragm and electro-acoustic driver, wherein the lower tackiness is obtained by generating SiO₂ on or within at least one part of the surface

3. claims: 7, 10, 11, 18(completely); 1, 9, 12, 17, 19(partially)

method for treating a silicone component, diaphragm and electro-acoustic driver, wherein the lower tackiness is obtained by forming a permanent silicone coating on top of the body

INTERNATIONAL SEARCH REPORT

Information on patent family members

International application No PCT/US2020/034504

Patent document cited in search report	Publication date	Patent family member(s)	Publication date
WO 2016030183 A1	03-03-2016	DE 102014217000 A1 DE 202015009591 U1 EP 3186300 A1 WO 2016030183 A1	03-03-2016 13-09-2018 05-07-2017 03-03-2016

WO 2016166227 A1	20-10-2016	EP 3283558 A1 EP 3283683 A1 JP 2018511686 A JP 2018511687 A US 2018100267 A1 US 2018104889 A1 WO 2016166224 A1 WO 2016166227 A1	21-02-2018 21-02-2018 26-04-2018 26-04-2018 12-04-2018 19-04-2018 20-10-2016 20-10-2016

WO 2018007372 A1	11-01-2018	CN 109417670 A WO 2018007372 A1	01-03-2019 11-01-2018

US 2017359657 A1	14-12-2017	CN 109328465 A EP 3469811 A1 JP 2019522414 A US 2017359657 A1 US 2018160231 A1 US 2019268699 A1 WO 2017218134 A1	12-02-2019 17-04-2019 08-08-2019 14-12-2017 07-06-2018 29-08-2019 21-12-2017
