



US 20150360776A1

(19) **United States**

(12) **Patent Application Publication**
Briod et al.

(10) **Pub. No.: US 2015/0360776 A1**

(43) **Pub. Date: Dec. 17, 2015**

(54) **VERTICAL TAKE-OFF AND LANDING
AERIAL VEHICLE**

Publication Classification

(71) Applicant: **Ecole Polytechnique Federale de
Lausanne (EPFL), Lausanne (CH)**

(51) **Int. Cl.**
B64C 29/00 (2006.01)

(72) Inventors: **Adrien Briod, Lausanne (CH); Mariusz
Przemyslaw Kornatowski, Ecublens
VD (CH); Adam Klaptocz, Lausanne
(CH); Jean-Christophe Zufferey,
Etagneries (CH); Dario Floreano,
St-Prex (CH)**

(52) **U.S. Cl.**
CPC **B64C 29/0091** (2013.01)

(57) **ABSTRACT**

A VTOL (vertical take-off and landing) aerial flying vehicle comprising an inner frame, a gimbal system and an outer frame, the inner frame comprising a propulsion system and a control system. The propulsion system being able to generate a lift force. The control system being able to control the orientation of the inner frame. The gimbal system connecting the inner frame to the outer frame with at least two rotation axis allowing rotation freedom between the outer frame to rotate independently from the inner frame.

(21) Appl. No.: **14/301,639**

(22) Filed: **Jun. 11, 2014**

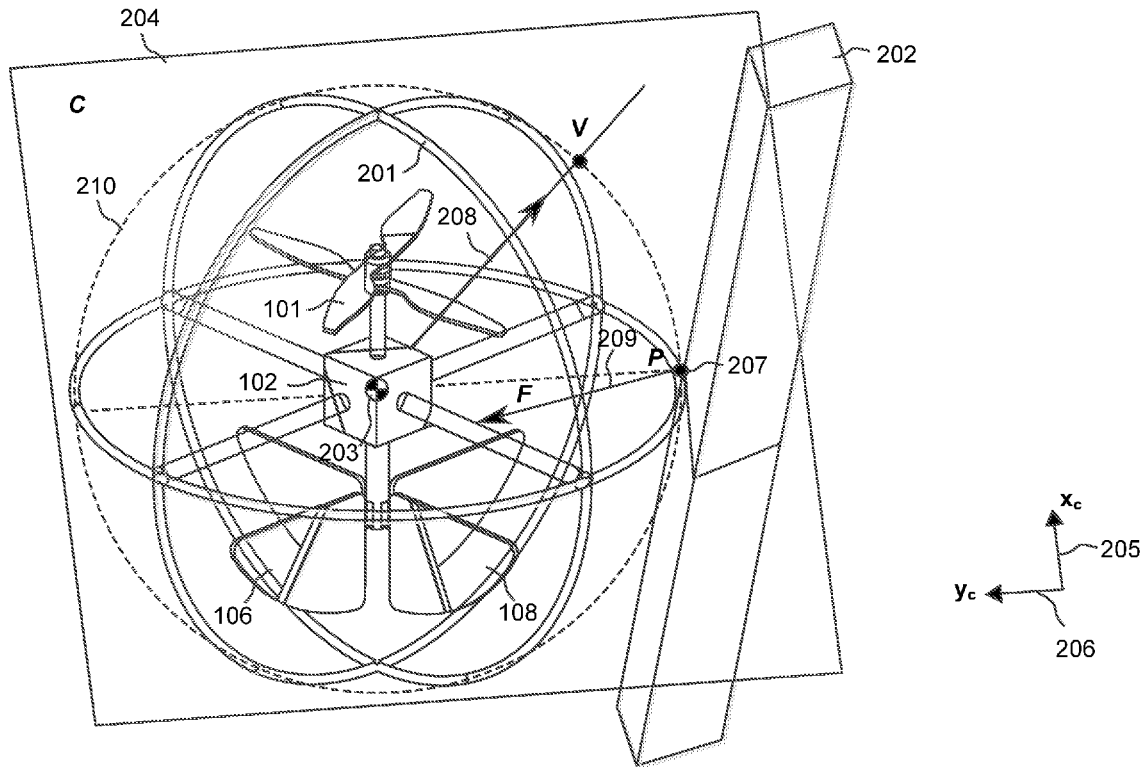

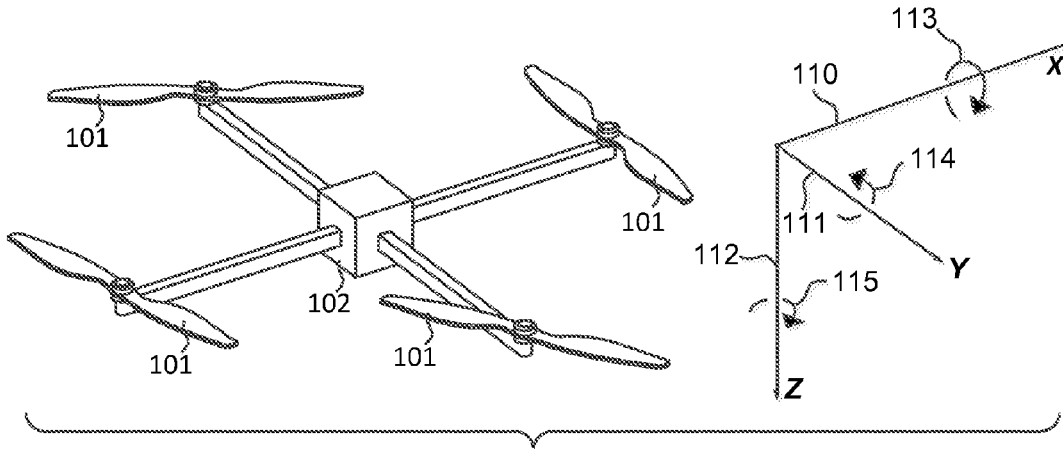

FIG. 1A
PRIOR ART

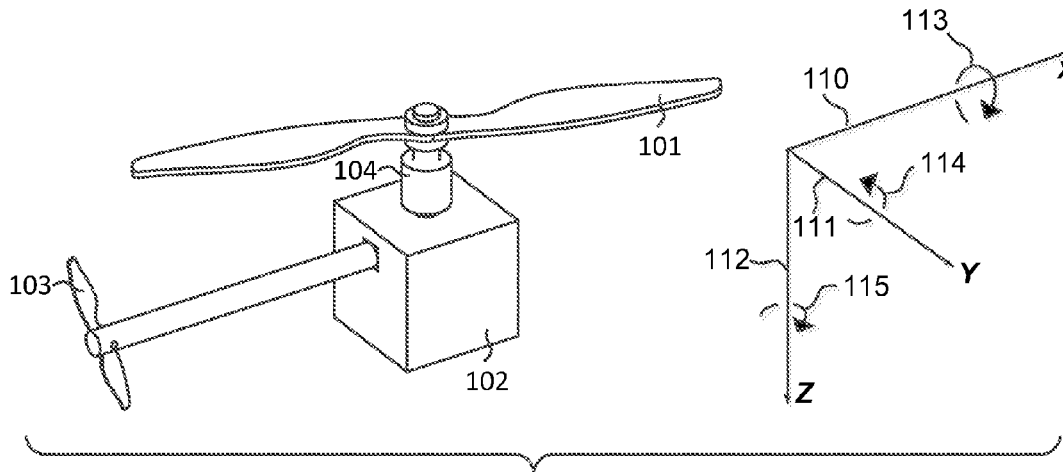

FIG. 1B
PRIOR ART

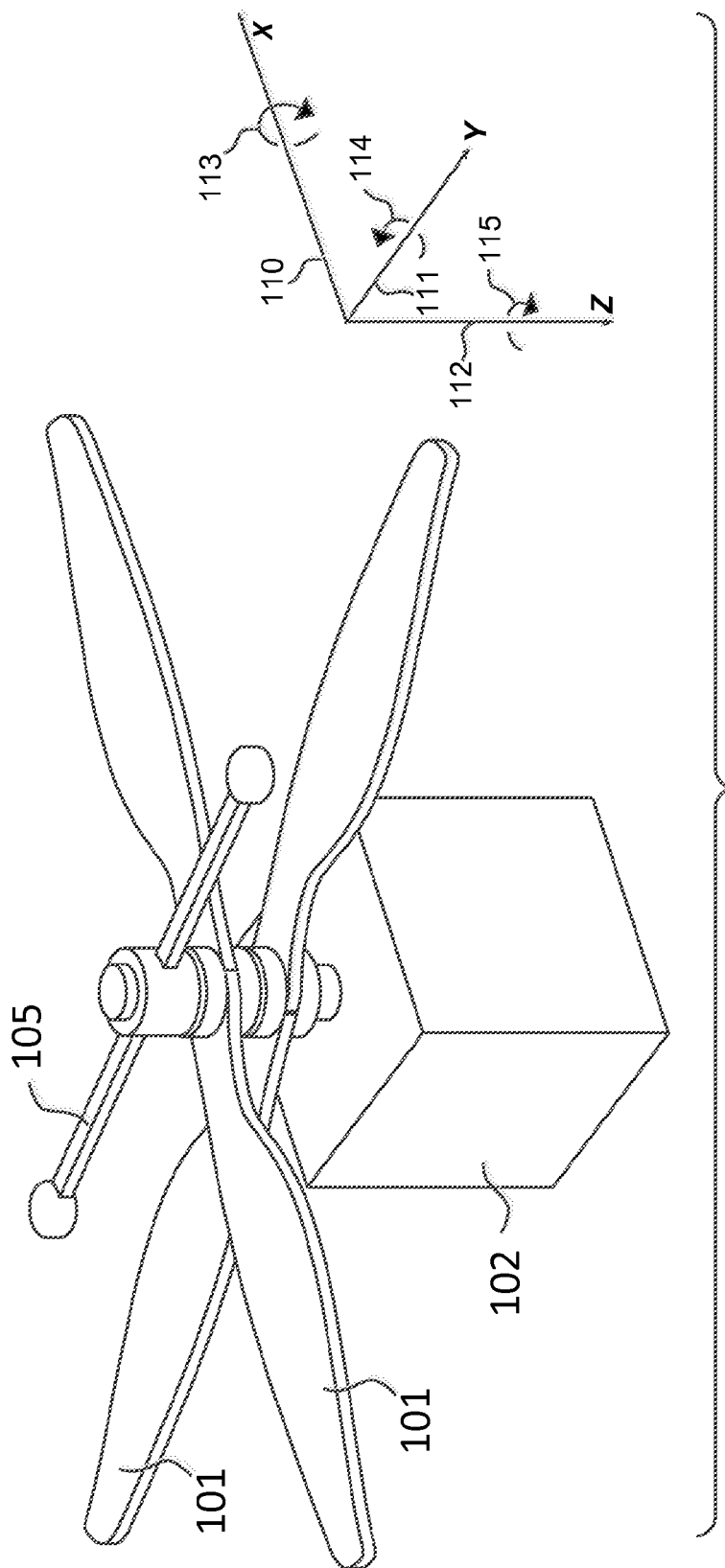

FIG. 1C
PRIOR ART

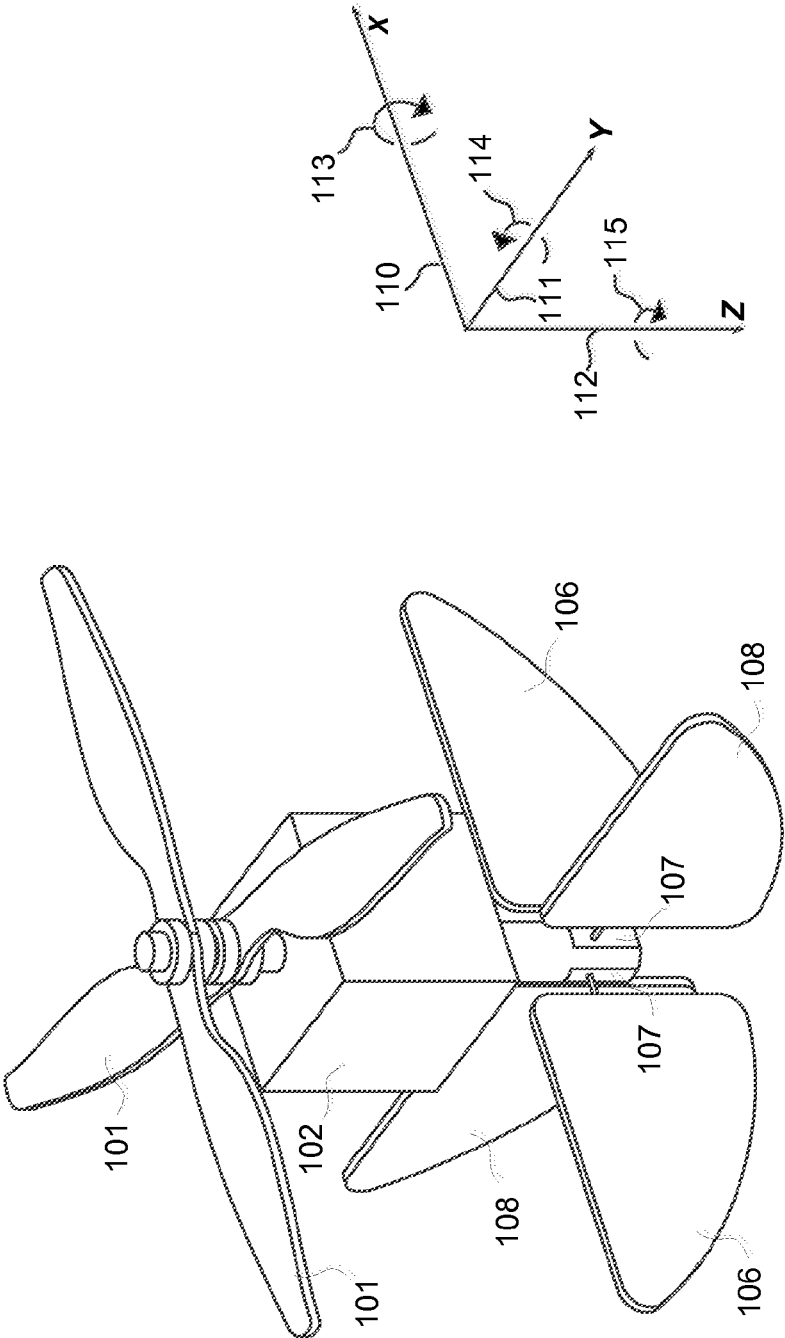

FIG. 1D
PRIOR ART

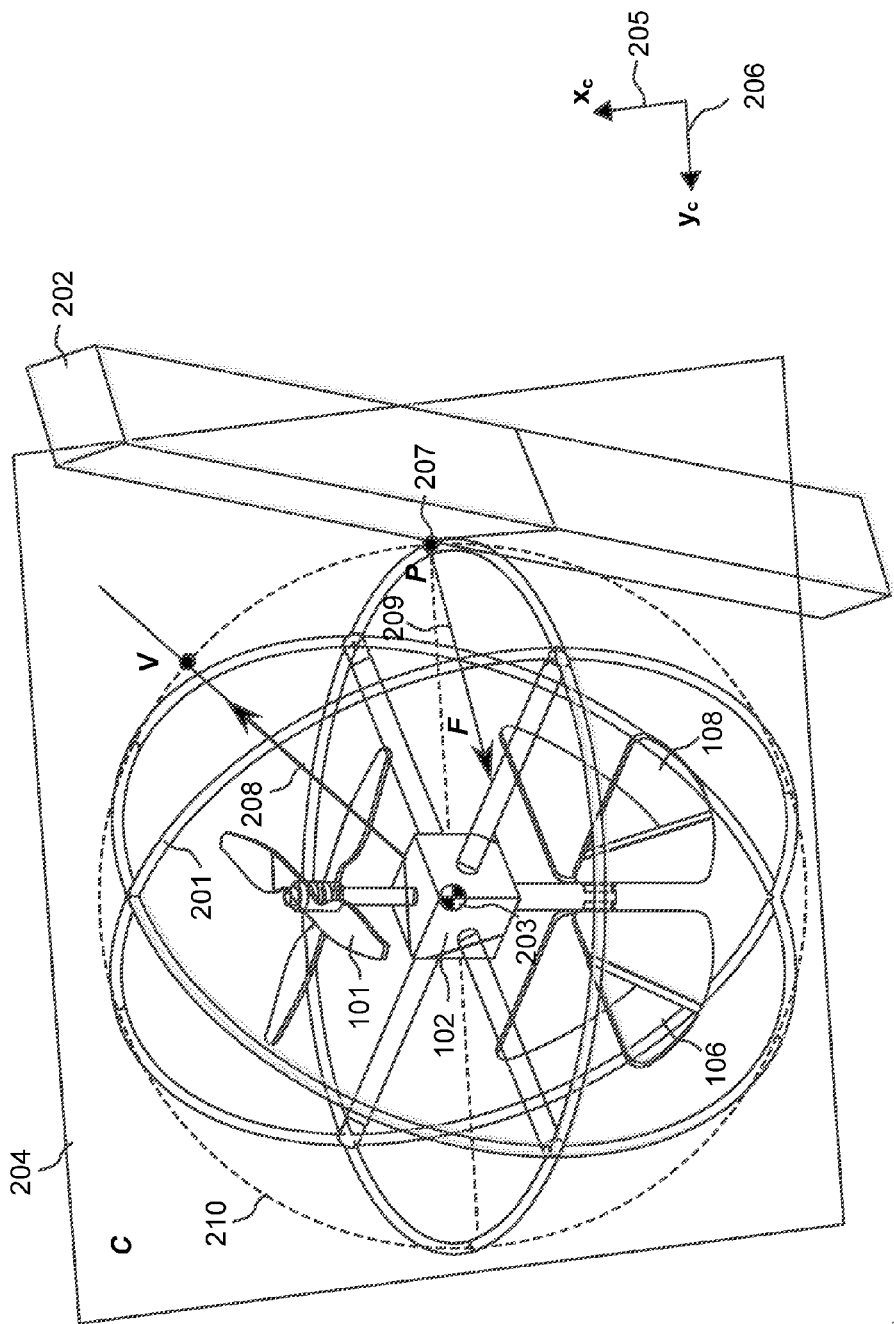

FIG. 2A

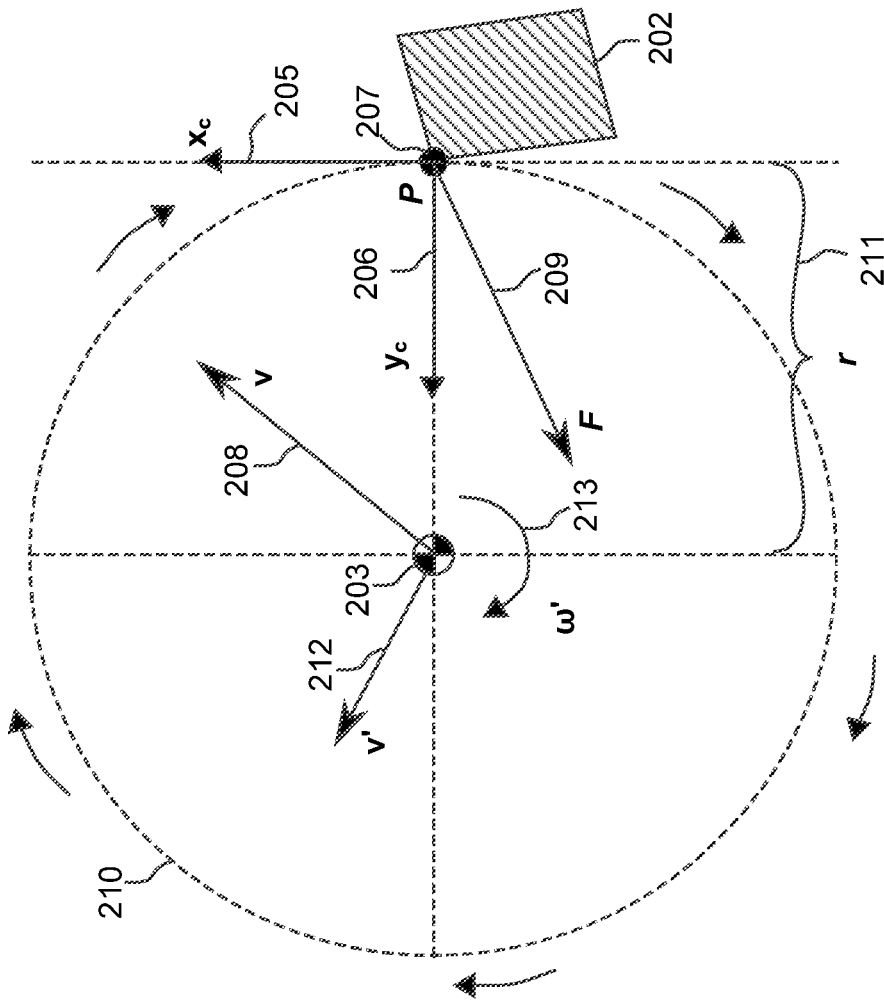

FIG. 2B

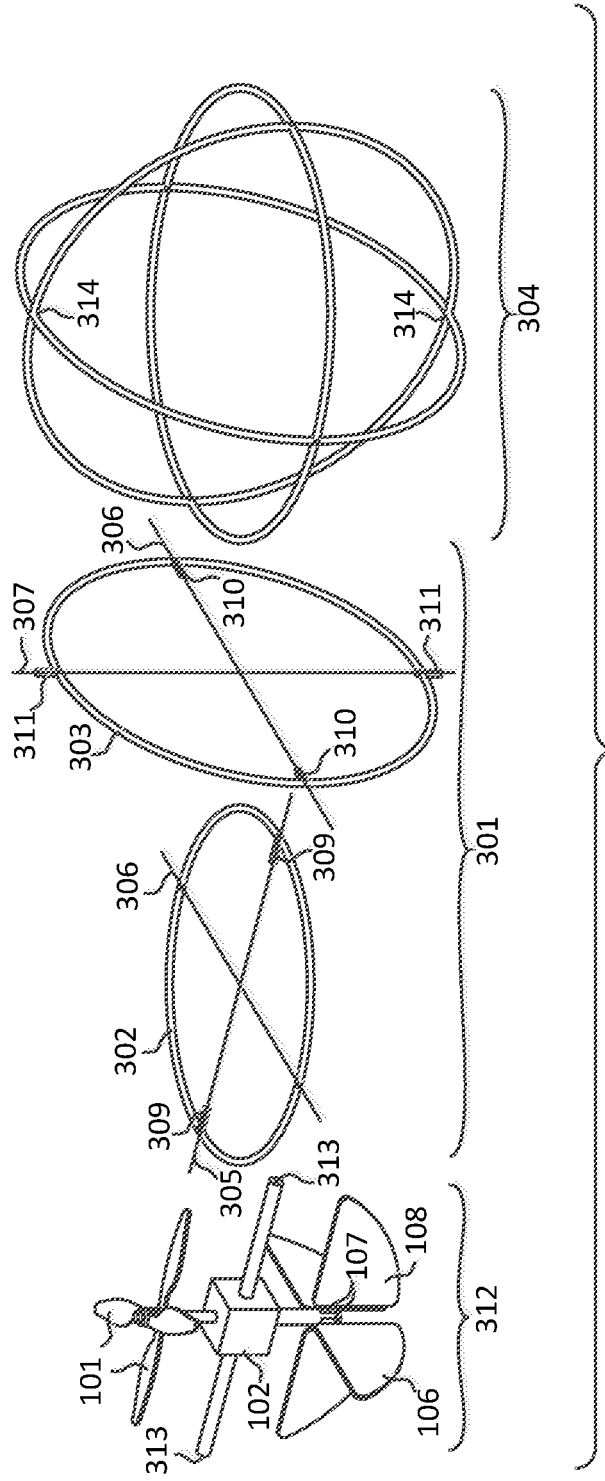

FIG. 3A

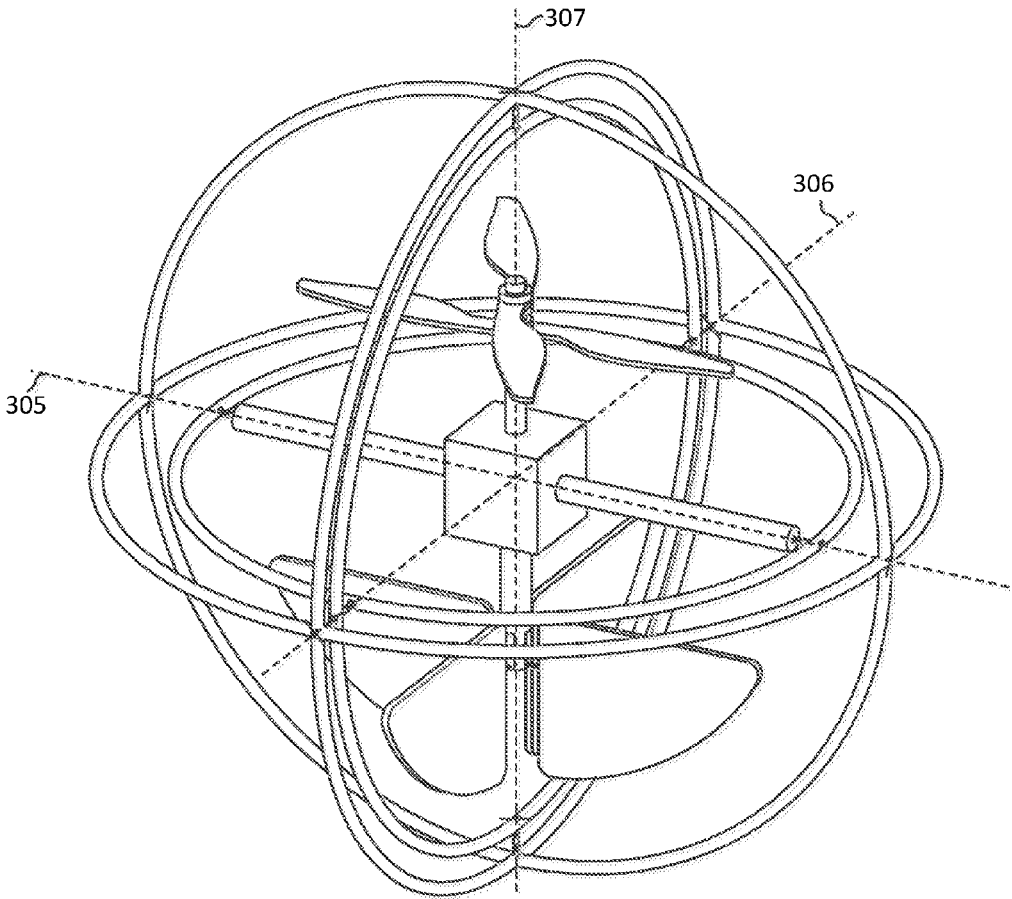

FIG. 3B

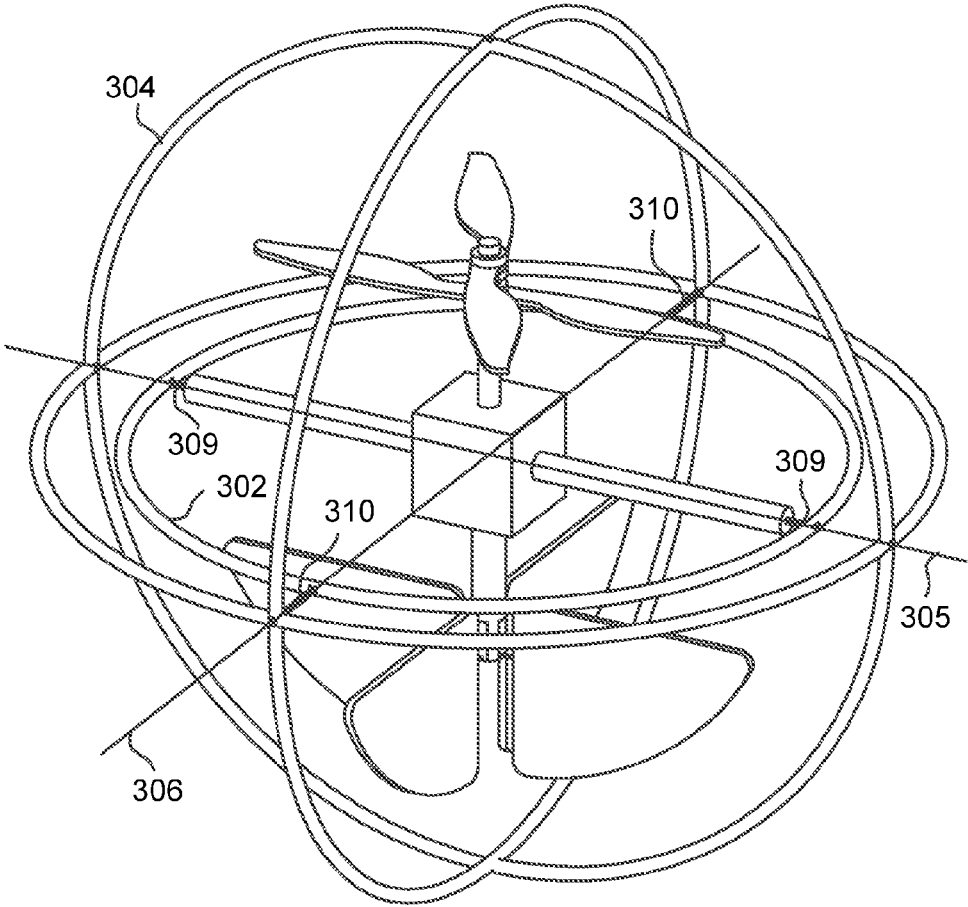

FIG. 4

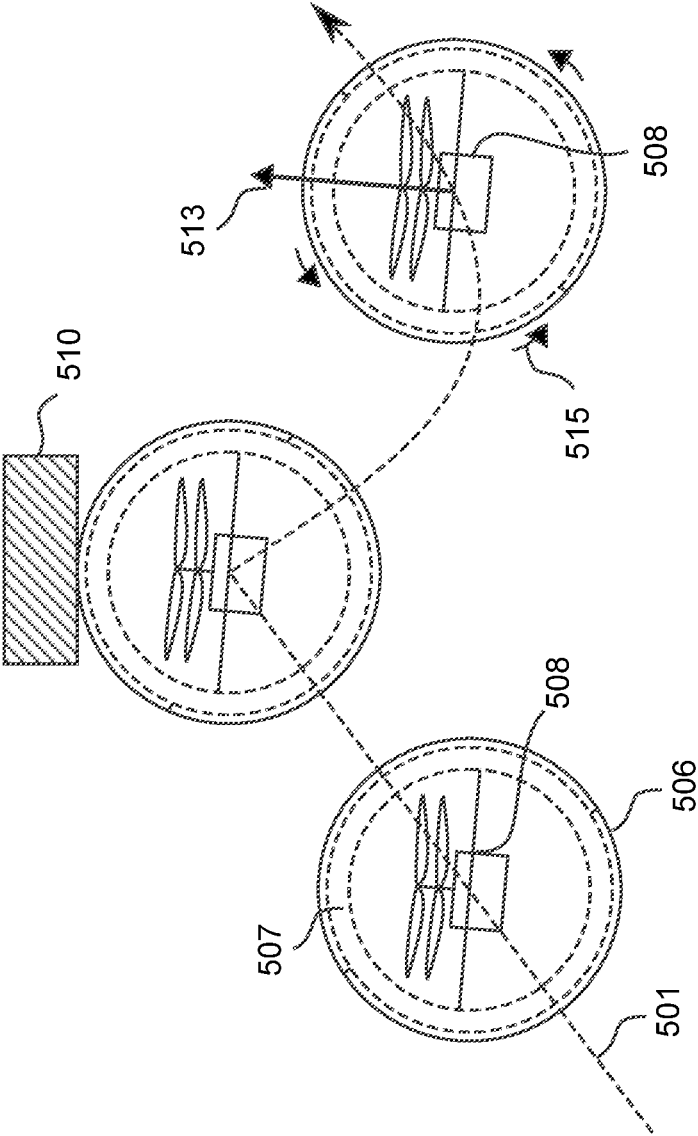

FIG. 5A

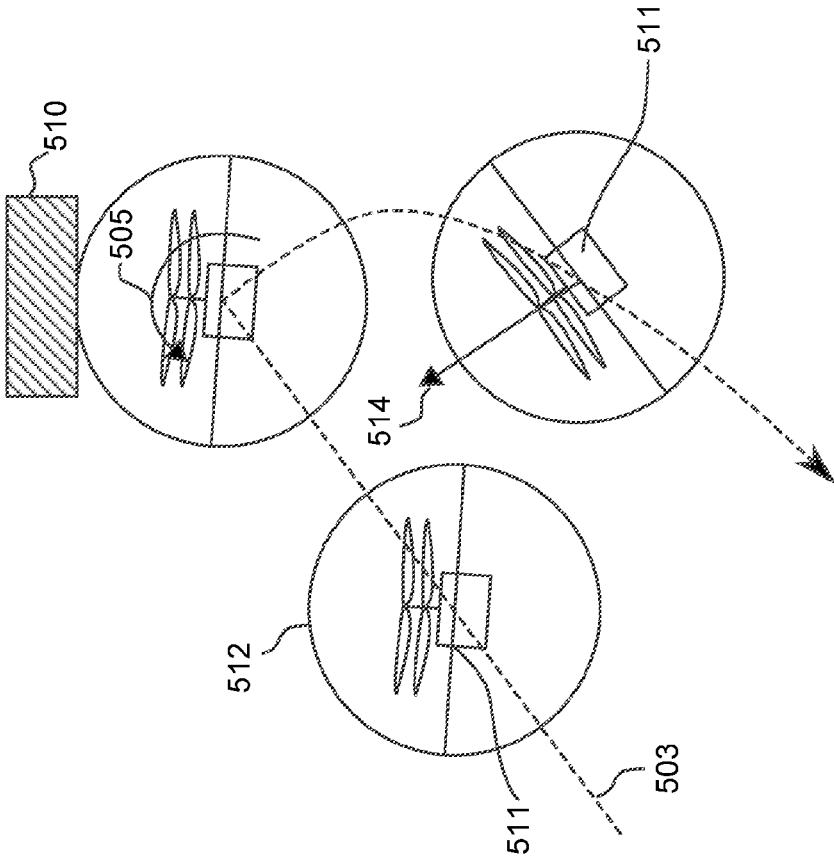

FIG. 5B

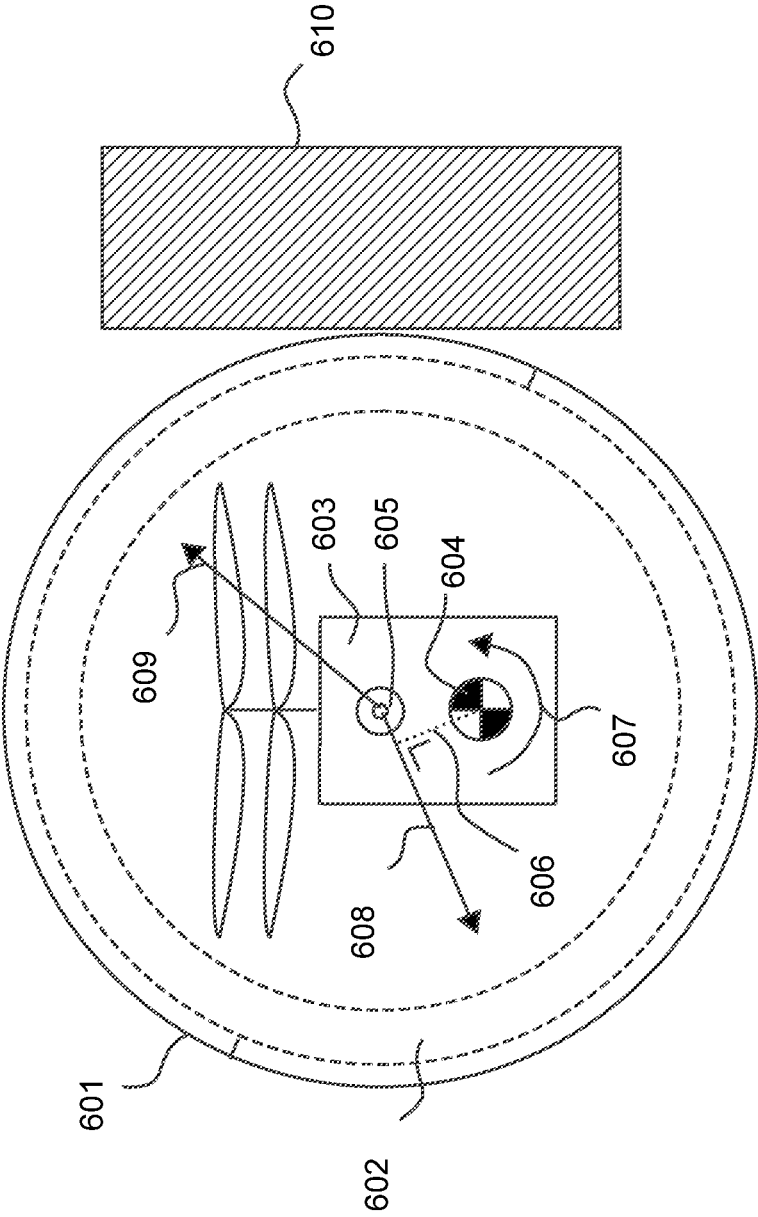

FIG. 6

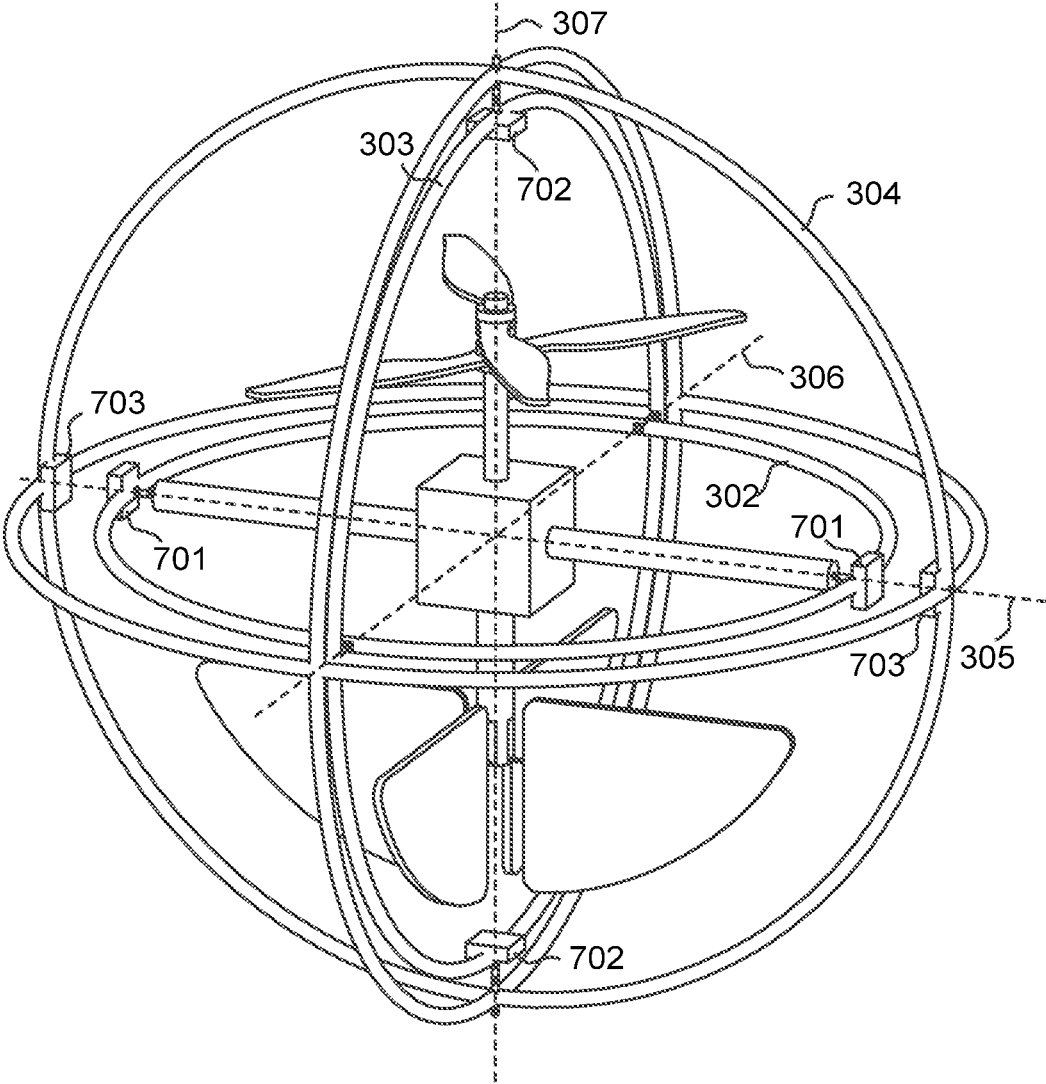

FIG. 7

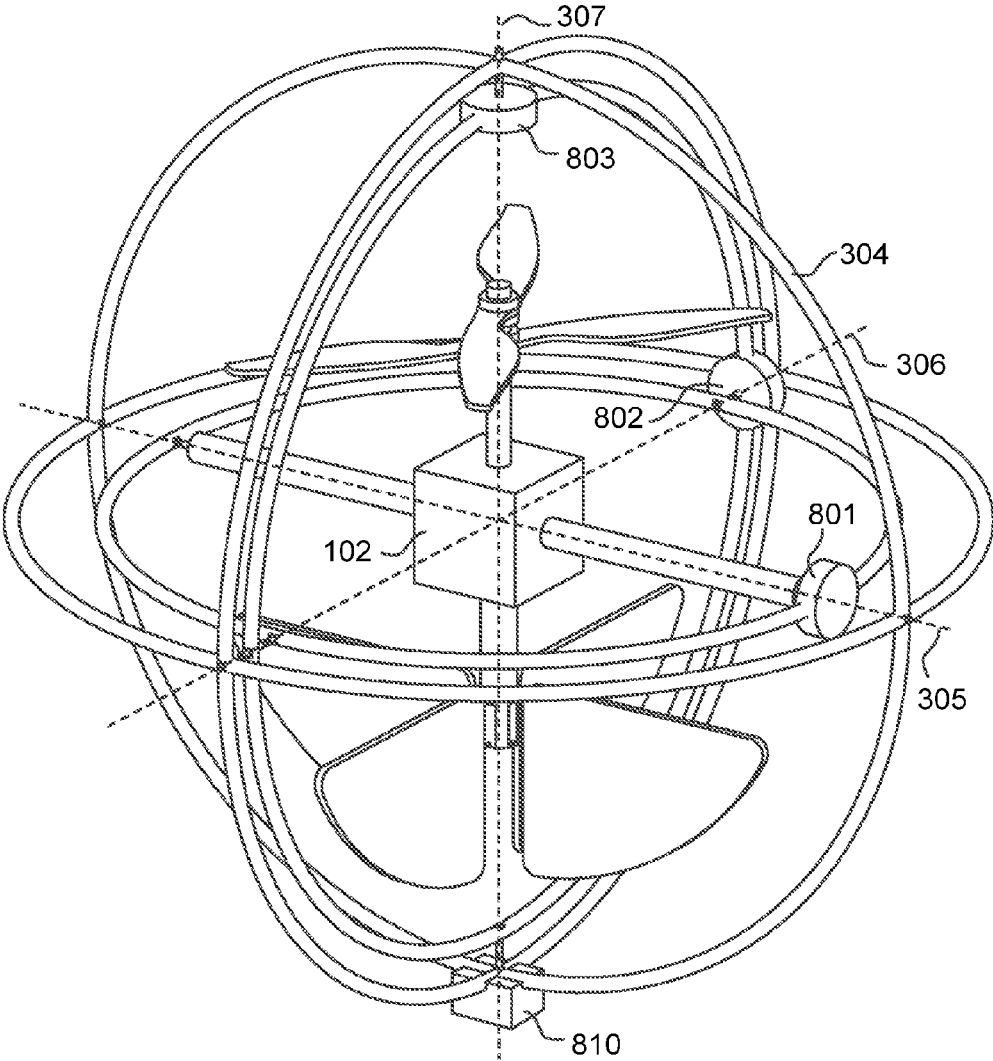

FIG. 8

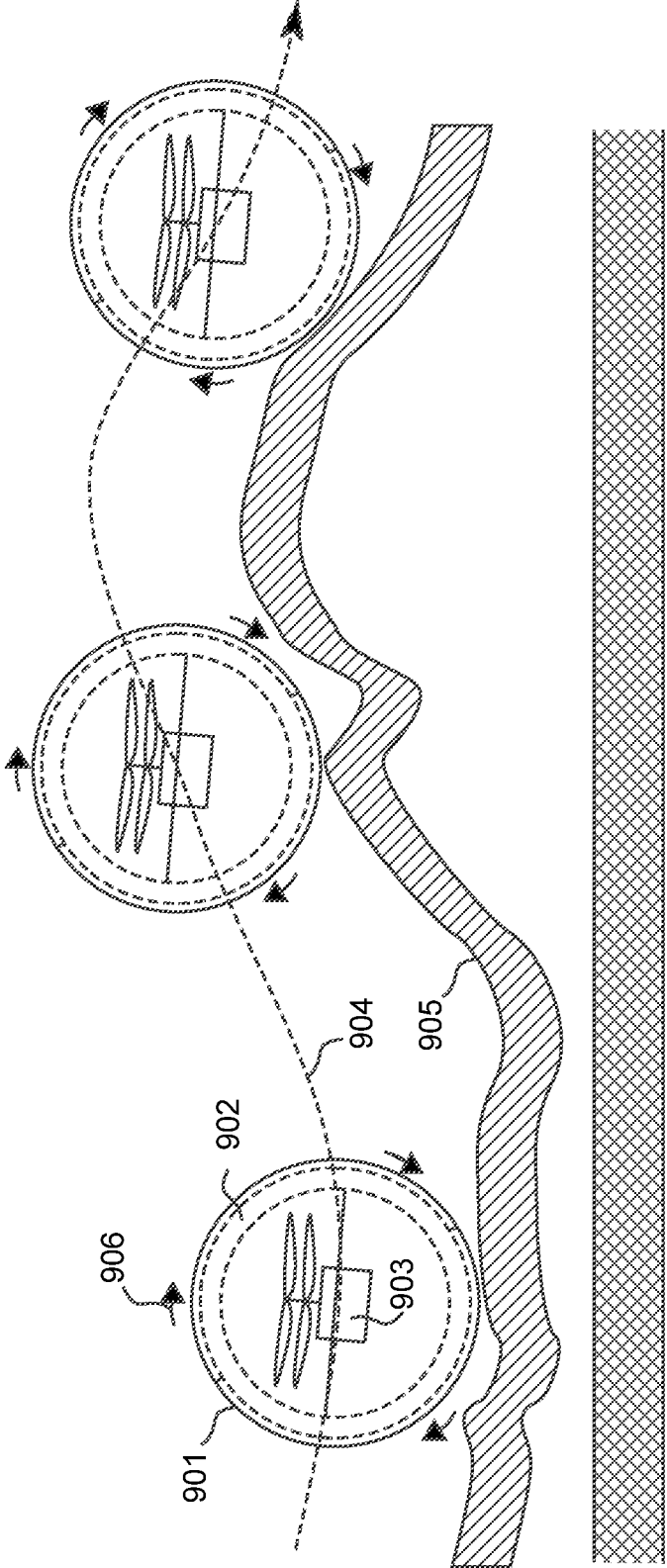

FIG. 9

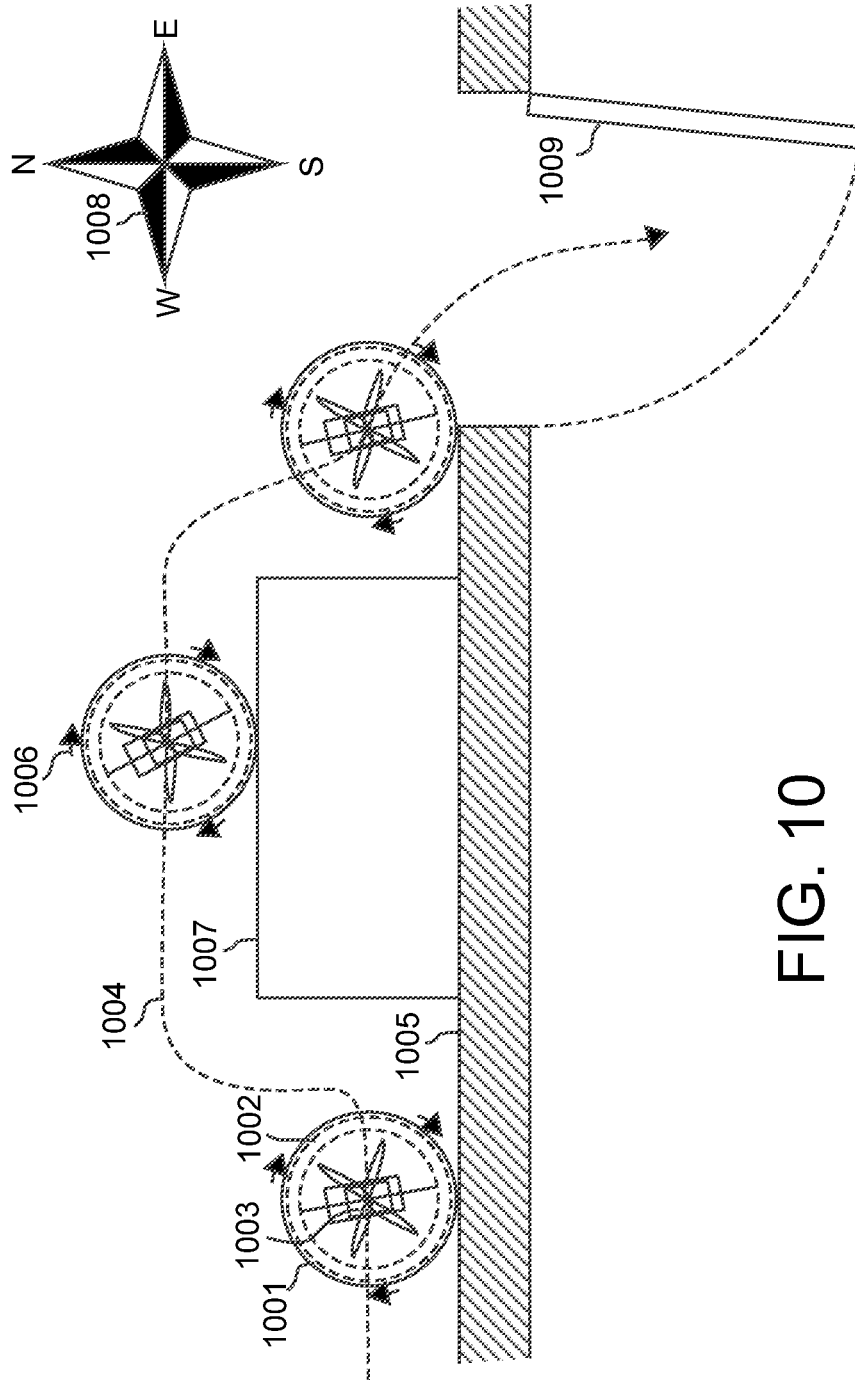

FIG. 10

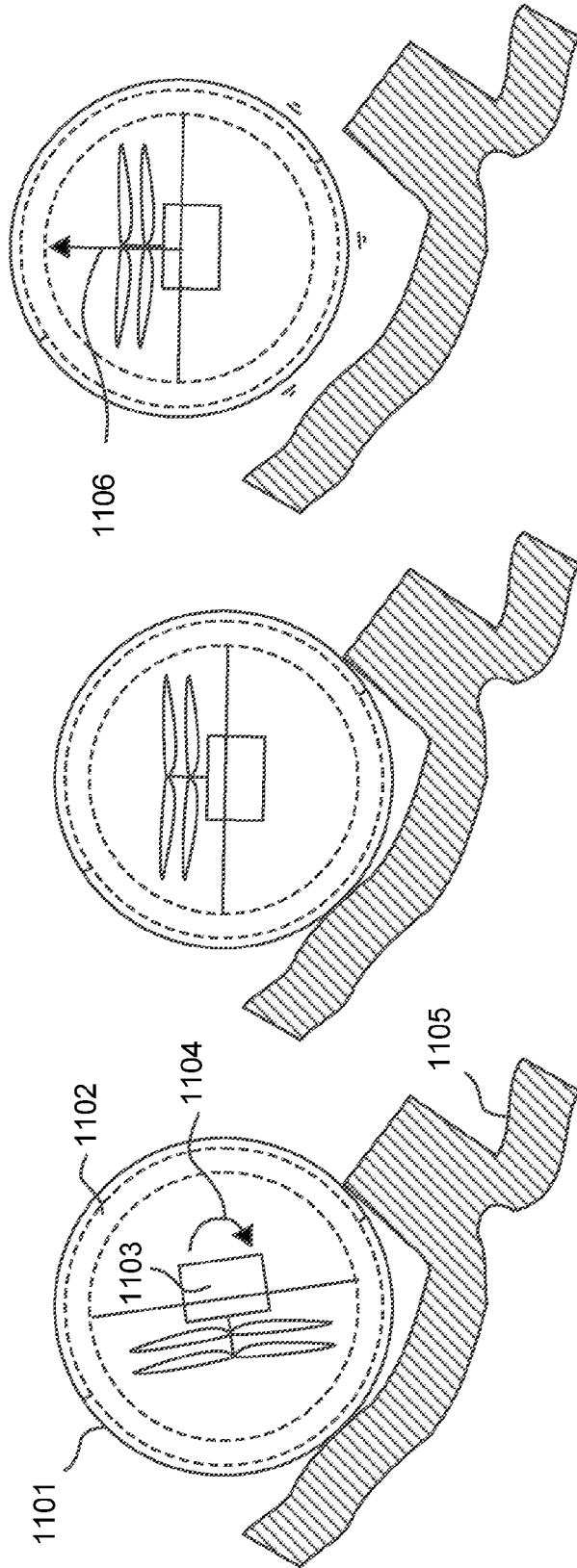

FIG. 11(c)

FIG. 11(b)

FIG. 11(a)

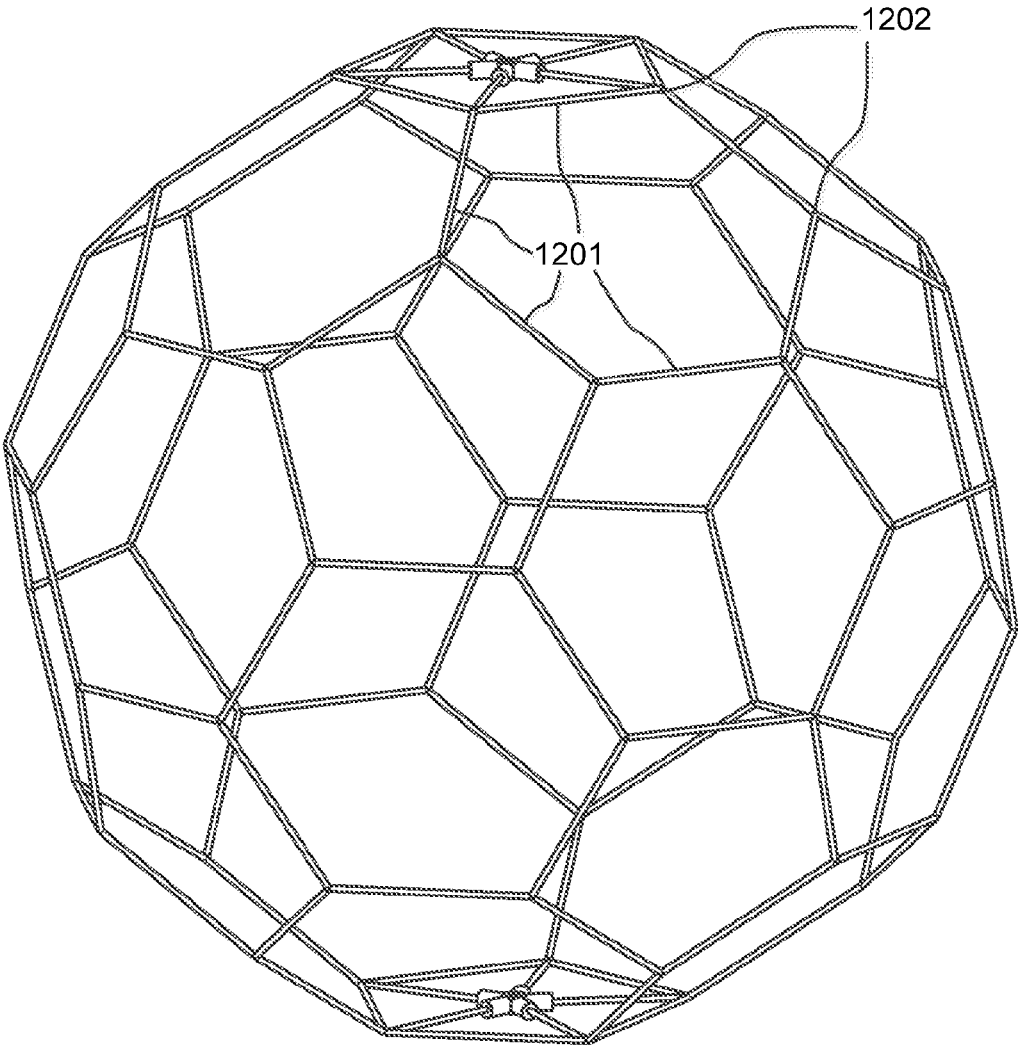

FIG. 12A

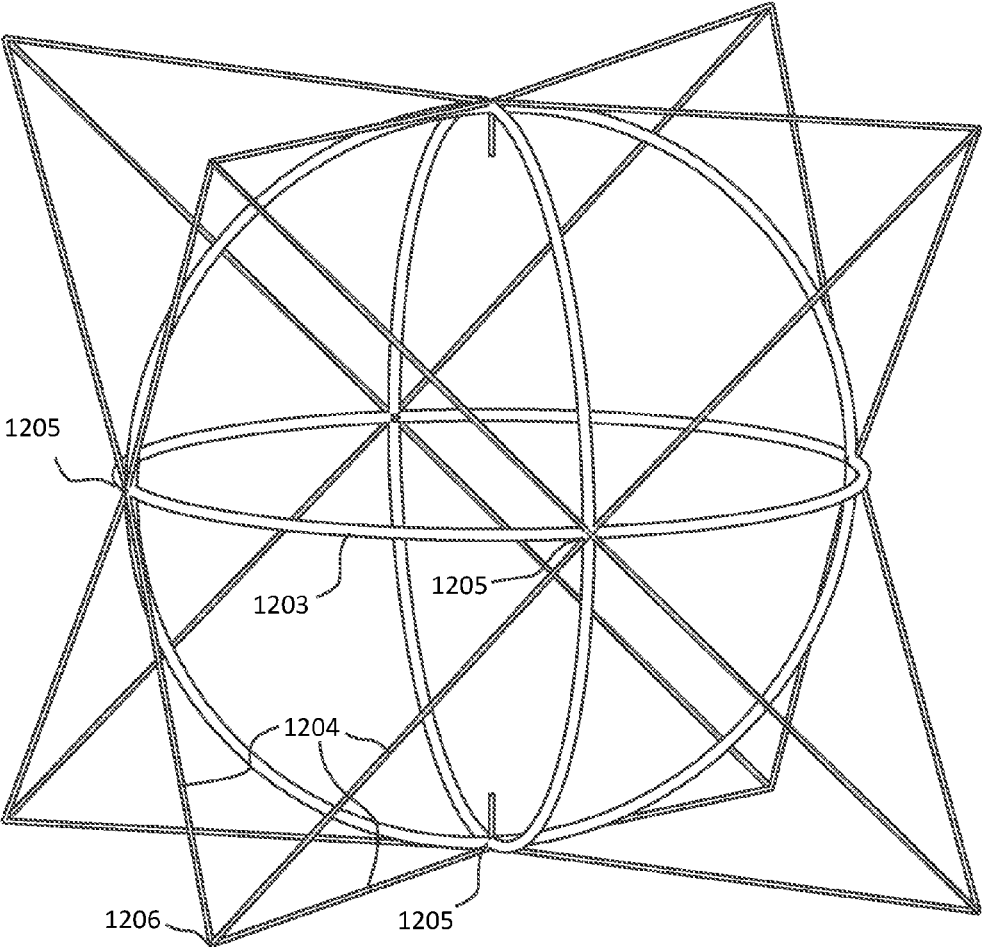

FIG. 12B

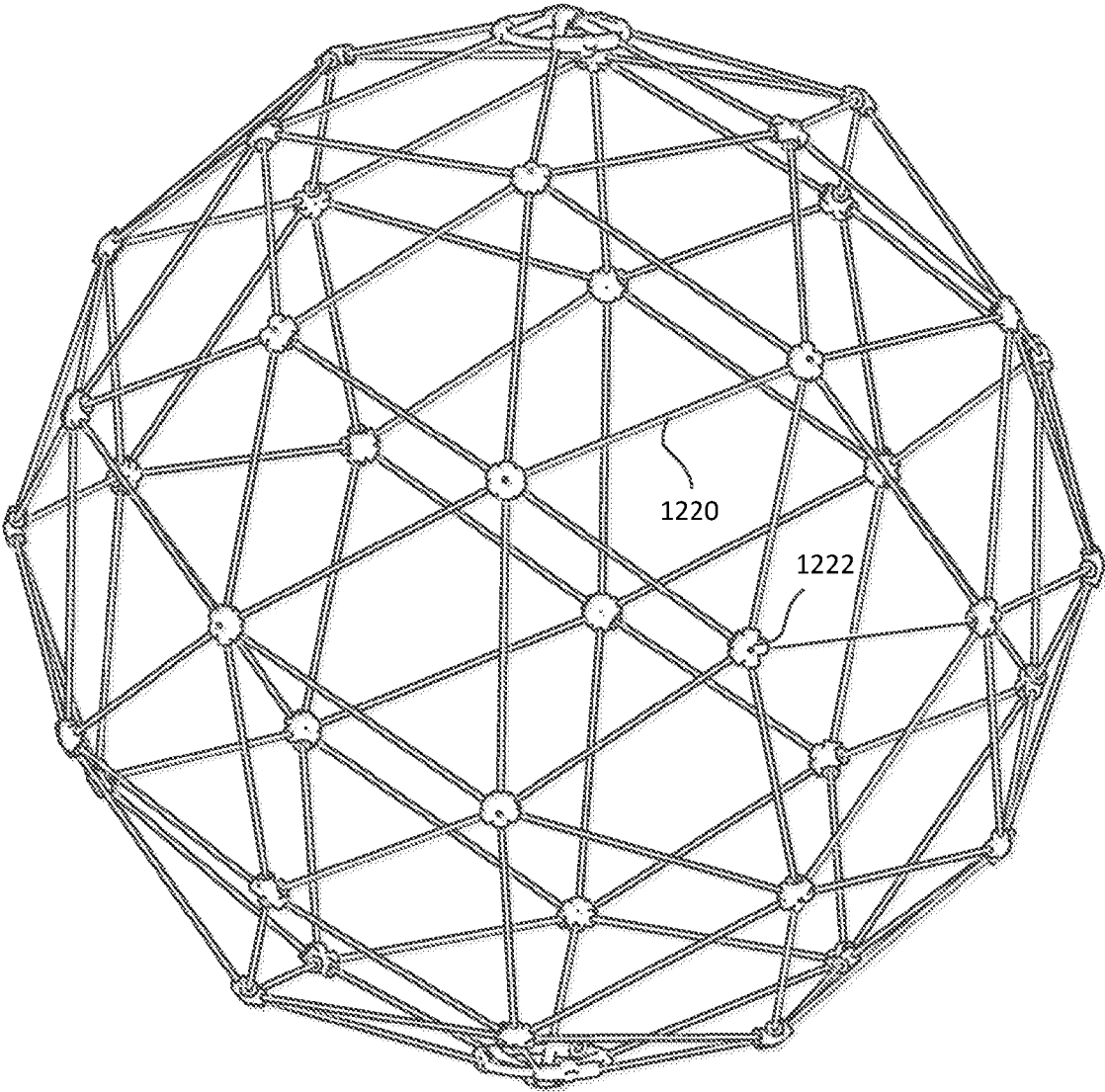

FIG. 12C

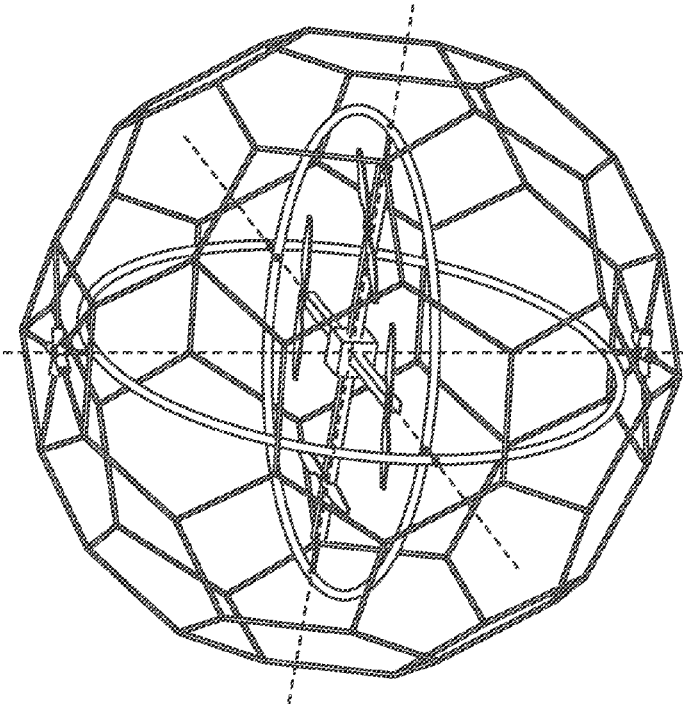

FIG. 13B

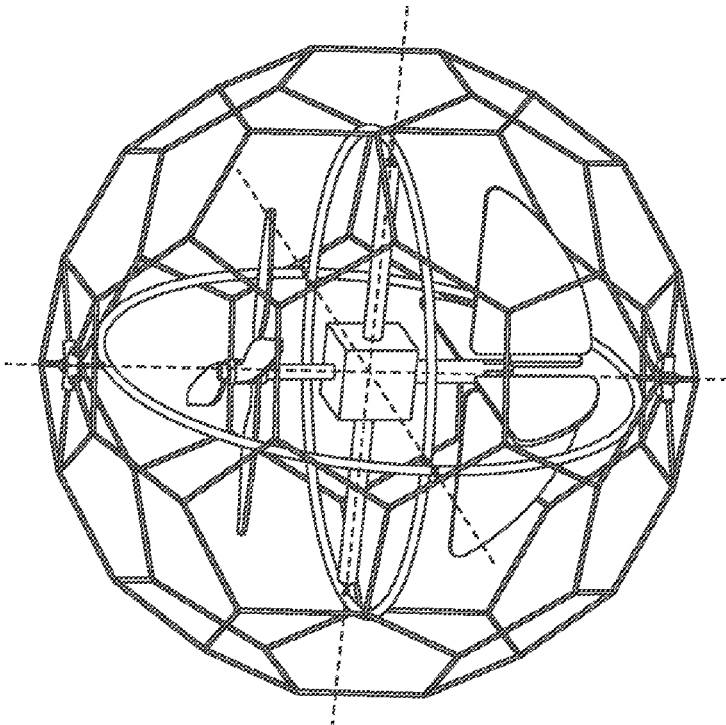

FIG. 13A

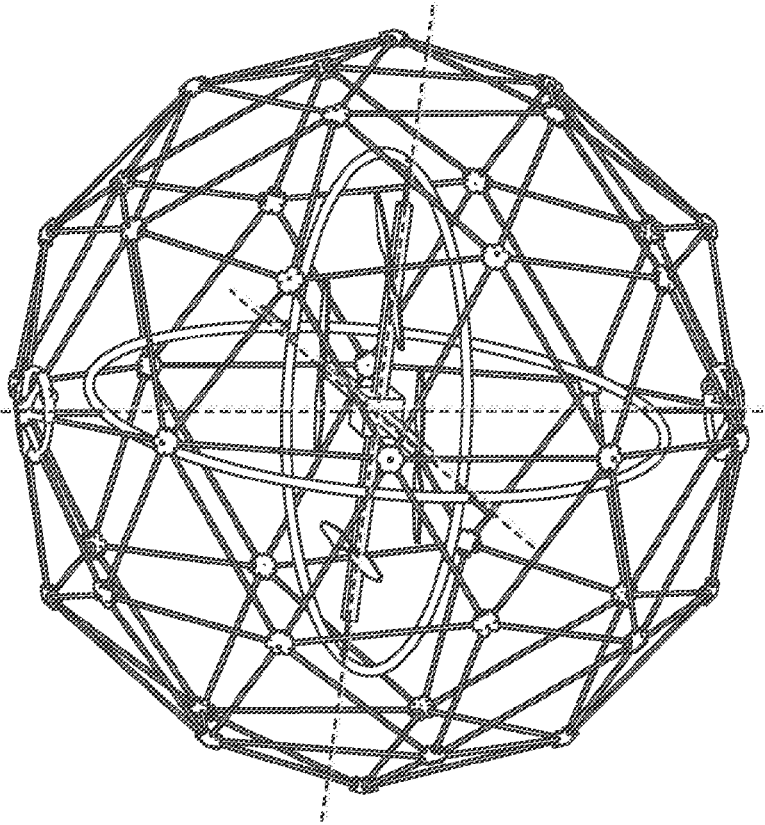

FIG. 13D

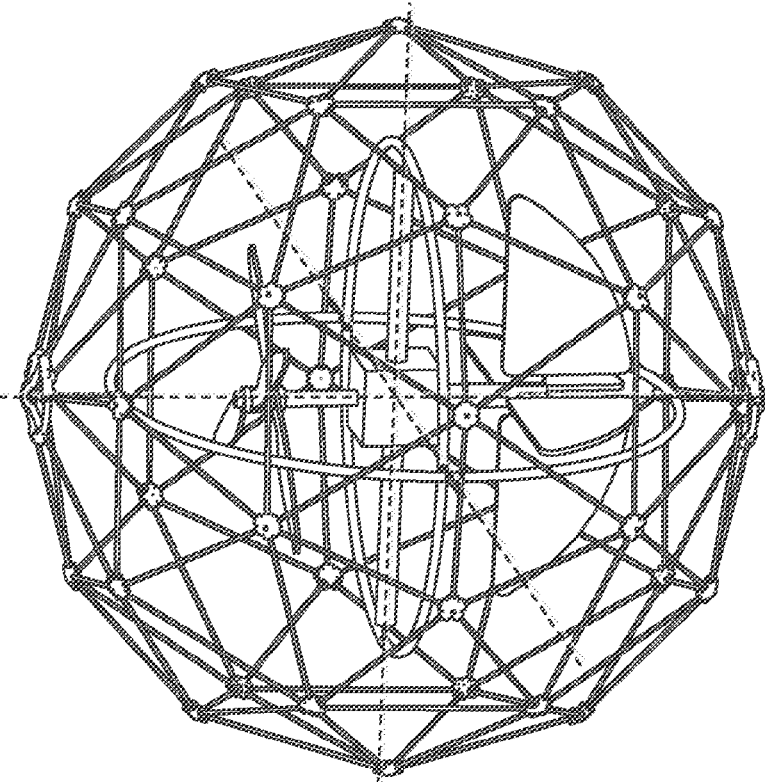

FIG. 13C

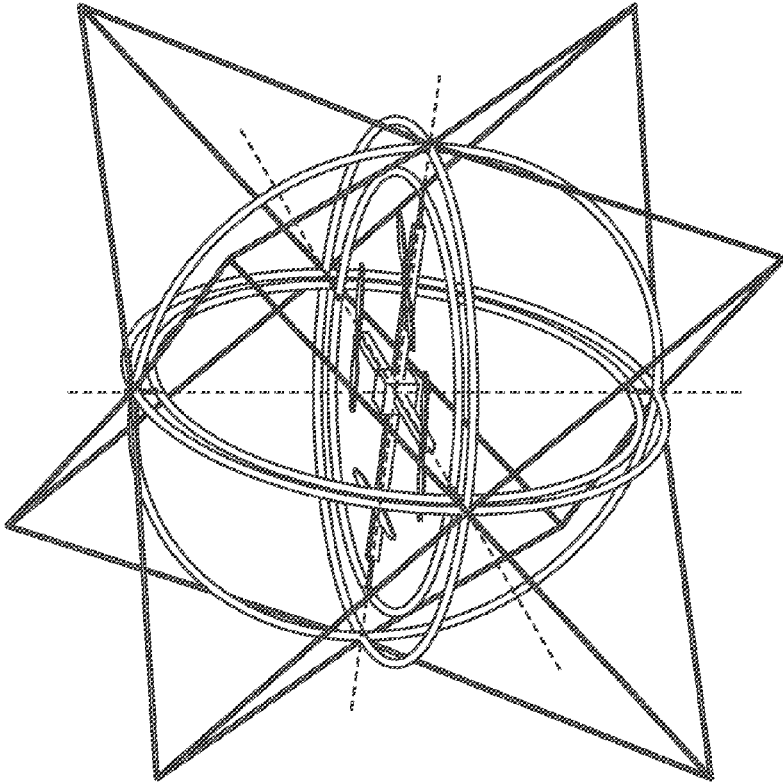

FIG. 14B

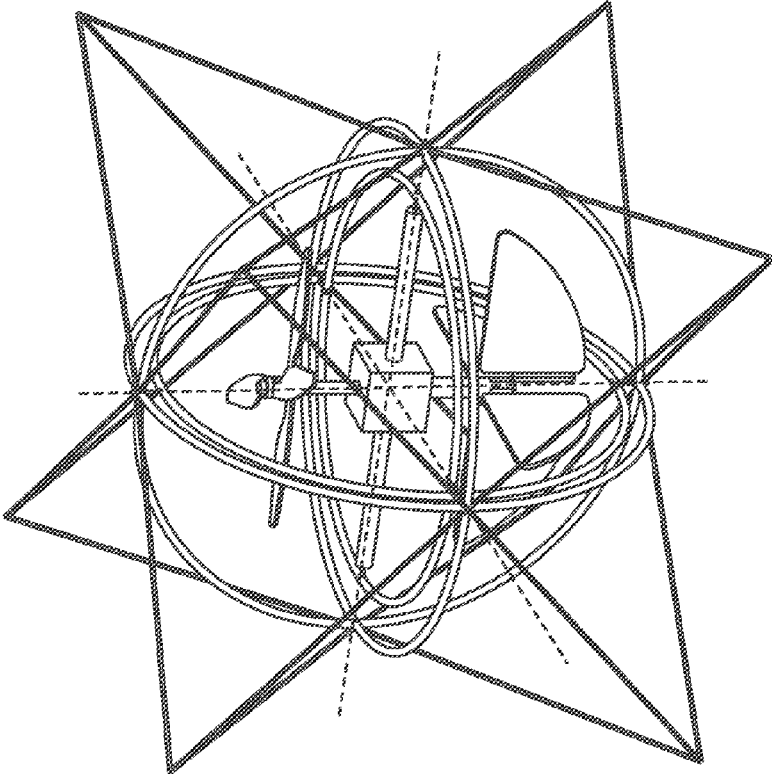

FIG. 14A

VERTICAL TAKE-OFF AND LANDING AERIAL VEHICLE

CROSS-REFERENCE TO RELATED APPLICATION DATA

[0001] This application claims priority to EP application no. 13171364.6 filed on Jun. 11, 2013 and International Application No. PCT/EP14/62129 filed on Jun. 11, 2014, which are incorporated herein in their entirety.

TECHNICAL FIELD

[0002] The present invention concerns a vertical take-off and landing (VTOL) aerial vehicle.

BACKGROUND

[0003] VTOL aerial vehicles generally fly thanks to a propulsion system (e.g. one or more propellers) that generates an upward force (lift) to counter gravity. Such vehicles are capable of slow flight (hovering flight), vertical take-off or vertical landing, and have generally a control system to control their orientation or direction in order to stay in a stable orientation or to move sideways. When the aerial vehicle is not in a stable orientation, e.g. its propulsion system creates a force that is not pointing mostly upwards, the aerial vehicle can quickly lose lift, or gain speed towards the direction in which the propulsion system creates a force.

[0004] VTOL aerial vehicles that stay aloft using a propulsion system and a control system exist in several configurations known in the prior art. Examples of such VTOL aerial vehicles comprising a propulsion system and a control system are illustrated in FIG. 1(a) through FIG. 1(d) for reference (many more types exist but are not illustrated in the Figs.). The propulsion system usually comprises one or more propellers **101**, and provides the lift force that keeps the aerial vehicle in the air. The control system can take various forms and usually comprises some control electronics **102** and possibly additional actuators not used to generate lift, but rather to generate forces or torques around the roll **110**, pitch **111** or yaw **112** axis, in order to control the roll **113**, pitch **114** and the yaw **115** motions, or in other words the aerial vehicle's orientation and thus the direction of the lift force. Such aerial vehicles stay in the air by remaining in an orientation where the propulsion system generates a force that is mostly upwards (usually by having the propellers rotate approximately in the horizontal plane), and they move sideways by slightly tilting.

[0005] FIG. 1(a) illustrates a multi-rotor system, and specifically a quadrotor is illustrated. Such an aerial vehicle uses a propulsion system comprising several horizontal propellers **101** generating lift. The control system determines the speed of each individual propeller to stabilize the aerial vehicle in a stable orientation or to tilt it so that it moves sideways. The differential actuation of opposite propellers generates torques around the pitch and roll axes. The differential actuation of propellers turning in opposite directions generates a torque around the yaw axis.

[0006] FIG. 1(b) illustrates a typical helicopter propulsion system. This aerial vehicle uses one main horizontal propeller **101** as a propulsion system to generate lift. The control system controls the pitch and roll motions of the aerial vehicle thanks to a swash-plate **104** that actuates the pitch of the main propeller's blades and stabilizes the pitch and roll of the aerial

vehicle, or tilts it to move sideways. A vertical tail propeller **103** is used to control the yaw angle.

[0007] FIG. 1(c) illustrates a co-axial design with fly-bar. Such an aerial vehicle uses two horizontal propellers **101** rotating in opposite directions as a propulsion system. The control system comprises a fly-bar **105** that keeps the pitch and roll angles stable. The fly-bar is a rigid rod with a relatively high moment of inertia that rotates together with the top propeller and remains horizontal thanks to inertia. It is mechanically linked to the pitch of the upper propeller's blades so that when the aerial vehicle's orientation is disturbed, the propeller creates a torque that brings back the aerial vehicle in a stable orientation. The differential actuation of the two propellers allows control of the yaw angle. The lower propeller can be equipped with a swash-plate in order to control the pitch and roll motions, and thus move the aerial vehicle sideways.

[0008] FIG. 1(d) illustrates a co-axial design with control surfaces. This aerial vehicle uses two horizontal propellers **101** rotating in opposite directions as a propulsion system. The control system uses one pair of control surfaces **108** to control the pitch motion and another pair of control surfaces **106** to control the roll motion. The control surfaces are actuated by two actuators **107**, and generate forces by deflecting the airflow generated by the propulsion system. The differential actuation of the two propellers allows control of the yaw angle.

[0009] Aerial vehicles designed to fly close to obstacles, such as disclosed in EP2517767A2 "Self-righting frame and aeronautical vehicle" to J. Dees and G. Yan, are often equipped with protective structures typically surrounding the propulsion system and control system. These protective structures prevent external objects from damaging sensitive parts such as rotating propellers or control surfaces, or absorb collision energy when the aerial vehicle collides into obstacles or falls to the ground. They are generally built so that openings allow the airflow to go through the structure without affecting too much the lift force generated by the propulsion system. The shape of the protective structures can be designed so that the aerial vehicle will upright passively to a vertical take-off orientation when it lies on flat ground.

[0010] A few existing VTOL aerial vehicles use protective structures with moving parts in order to improve the interaction with the environment. As described in M. Itasse, J.-M. Moschetta, Y. Ameho, and R. Can, "Equilibrium Transition Study for a Hybrid MAV," *International Journal of Micro Air Vehicles*, vol. 3, no. 4, pp. 229-246, December 2011, a dual-motor VTOL is equipped with two passively rotating wheels that both protect the rotors from contact, and can be used to roll on the ground or even along the wall when in flight. However, the wheels can only protect the inner frame of the aerial vehicle from touching flat obstacles, and the aerial vehicle can only roll toward a single direction.

[0011] In A. Kalantari, and M. Spenko, "Design and Experimental Validation of HyTAQ, a Hybrid Terrestrial and Aerial Quadrotor," *IEEE International Conference on Robotics and Automation*, 2013, a protective cage is described that can passively rotate around one axis and offers better protection, which allows the VTOL aerial vehicle to roll on uneven ground towards a single direction only. While these aerial vehicles demonstrate passively rotating protective structures for rolling on obstacles, their rolling direction is constrained to a single direction because of the single axis of rotation. Also, among other things, these mechanisms do not address

the problem of reducing disturbances occurring from in-flight collisions with obstacles. An aerial vehicle described in US2010/0224723A1, "Aerial Vehicle" to J. Apkarian, features a protective structure that can rotate around two different axes. However, the rotation axes are fully actuated and controlled at all time by motors. Among other things, the actively controlled rotation of the structure only allows the stabilization of the aerial vehicle during flight by changing the position of the center of mass of the protective structure. This design does not allow for disturbance reduction when colliding in flight with obstacles, or for rolling on obstacles (e.g. in contact with obstacles during flight).

[0012] U.S. Pat. No. 6,976,899 to Tamanas describes an "all terrain vehicle" comprised of three connected rings, a cradle attached to the innermost ring and configured such that the vehicle rolls upon the ground while the cradle remains upright. Among other things, while the all terrain vehicle is configured to travel over various ground surfaces, the all terrain vehicle is not configured and has no application as a vertical take-off and landing aerial vehicle.

[0013] When an aerial vehicle enters into contact with an obstacle, relatively large external torques and forces can disturb the orientation of the aerial vehicle. While an onboard control system (mechanical and/or software) might counter some amount of disturbances and bring back the aerial vehicle in a stable orientation for flying, such control systems are often unable to correct quickly the large disturbances occurring after a contact with external objects. Such contacts can thus provoke large perturbations of the aerial vehicle's orientation or trajectory, or even lead to a crash to the ground. Most aerial vehicles are thus always kept away from obstacles, to prevent any contact with obstacles. Additionally, most aerial vehicles can only take-off from one resting orientation, in which the propulsion system can create an upwards force, which limits their ability to take-off from uneven ground, or after landing in other orientations.

SUMMARY

[0014] The present disclosure describes a system that reduces the disturbances provoked by a contact with an external object, which allows aerial vehicles to collide with obstacles while remaining in a stable orientation most of the time. A vertical take-off and landing (VTOL) vehicle comprises an inner frame, a gimbal system and an outer frame. The gimbal system allows the outer frame to passively rotate independently from the inner frame, which reduces the disturbances provoked by a contact with an external object, allows rolling on obstacles and allows take-off from any orientation. The VTOL according to the disclosure allows the platform to stay in contact with an obstacle, be it below, sideways, or above the platform, and move with respect to the obstacle while staying in contact with it, which is described herein as rolling on it. The VTOL is configured as an aerial vehicle that can take-off from any orientation, even on uneven ground.

[0015] The VTOL according to the present disclosure comprises a propulsion system and a control system, the propulsion system being able to generate a lift force, the control system being able to control the orientation of the inner frame, the gimbal system connecting the inner frame to the outer and inner frames, i.e. the outer frame with at least two rotation axis allowing rotation freedom between the outer frame to rotate independently from the inner frame.

[0016] The rotation axis are configured to decouple mechanically the outer frame from the inner frame with the gimbal system, so that the outer frame can rotate passively around the inner frame. The inner frame contains the propulsion system and control system that keep the aerial vehicle aloft by generating an upward force and rejecting small disturbances, while the outer frame prevents external objects from touching the inner frame and affecting its orientation. The outer frame is geometrically configured to withstand substantial impacts and protect the VTOL inner frame, propulsion and control systems so that the VTOL can re-stabilize after impacts and continue to travel. Different designs for the outer frame structure are disclosed that reduce the forces occurring during a collision with obstacles.

[0017] The gimbal system allows the outer frame to rotate passively around the inner frame about two or more rotation axes. Therefore some or all of the torques applied to the outer frame will provoke its rotation about these axes, but will not affect the inner frame, so that the propulsion system remains in a stable orientation for hovering flight. An aerial vehicle configured according to the disclosure can thus collide with obstacles while its inner frame remains in a stable orientation, which prevents large instabilities or crashes of the aerial vehicle from occurring when the propulsion system experiences significant orientation perturbations.

[0018] Further, since the orientation of the inner frame is not constrained when the outer frame is in contact with obstacles, the control system is still able to make the aerial vehicle move sideways, up or down while the outer frame remains in constant contact with obstacles. This allows the aerial vehicle to fly towards different directions while staying in contact with external objects, walls or ceilings (in other words: it is able to roll on obstacles while in flight).

[0019] The disclosed system is also useful for taking-off from any orientation: when on the ground, the inner frame can rotate freely inside the outer frame and a mechanism can thus rotate the inner frame to an orientation appropriate for take-off (e.g. with the propulsion able to generate an upwards force). The rotation of the inner frame can be accomplished by placing the center of mass of the inner frame so that the gravity pulls it in the desired orientation, or by using the control system of the inner frame.

BRIEF DESCRIPTION OF THE FIGURES

[0020] The VTOL according to the disclosure will be better understood with reference to the accompanying figures, in which:

[0021] FIGS. 1(a)-1(d) illustrate various prior art propulsion system for VTOL aerial vehicles;

[0022] FIG. 2(a) illustrates an aerial vehicle according to the disclosure equipped with a protective frame rigidly attached to the control and propulsion system colliding into a beam;

[0023] FIG. 2(b) illustrates a 2D representation of the aerial vehicle of FIG. 2(a) on the collision plane;

[0024] FIG. 3(a) illustrates an exploded view of each main component of an aerial vehicle according to the disclosure;

[0025] FIG. 3(b) illustrates an embodiment of an aerial vehicle according to the disclosure equipped with a gimbal system allowing the outer frame to rotate according to three rotation axes;

[0026] FIG. 4 illustrates an embodiment of an aerial vehicle according to the disclosure equipped with a gimbal system allowing the outer frame to rotate according to two rotation axes;

[0027] FIGS. 5(a) and 5(b) illustrate a side view of two situations where an aerial vehicle according to the disclosure collides with an external object;

[0028] FIG. 6 illustrates a side view of the aerial vehicle equipped with a gimbal system according to the disclosure colliding with an obstacle;

[0029] FIG. 7 illustrates an embodiment of an aerial vehicle according to the disclosure equipped with a gimbal system and magnets to prevent the gimbals from reaching a gimbal lock position;

[0030] FIG. 8 illustrates an embodiment of an aerial vehicle according to the disclosure equipped with a gimbal system and actuators;

[0031] FIG. 9 illustrates a side-view of an aerial vehicle according to the disclosure equipped with a gimbal system that rolls on uneven ground;

[0032] FIG. 10 illustrates a top view of an aerial vehicle according to the disclosure equipped with a gimbal system that rolls on vertical obstacles;

[0033] FIG. 11(a) illustrates an aerial vehicle according to the disclosure equipped with a gimbal system resting on the ground at an orientation not appropriate for take-off;

[0034] FIG. 11(b) illustrates the aerial vehicle of FIG. 11(a) equipped with a gimbal system ready to take-off;

[0035] FIG. 11(c) illustrates the aerial vehicle of FIG. 11(b) taking off;

[0036] FIG. 12(a) illustrates an example of a protective outer frame based on beams outlining a spherical polyhedron, in particular a truncated icosahedron is illustrated;

[0037] FIG. 12(b) illustrates an example of a protective outer frame using tetrahedral bumpers made of three flexible beams attached to a rigid base;

[0038] FIG. 12(c) illustrates an example of a protective outer frame based on triangular structures forming modular components for ease of construction;

[0039] FIG. 13(a) illustrates an aerial vehicle equipped with a gimbal system and a spherical polyhedron as outer frame wherein an inner frame comprises a coaxial design with control surfaces;

[0040] FIG. 13(b) illustrates an aerial vehicle equipped with a gimbal system and a spherical polyhedron as outer frame wherein an inner frame comprises a multi-rotor;

[0041] FIG. 13(c) illustrates an aerial vehicle equipped with a gimbal system and an outer frame based on triangular structures forming modular components wherein an inner frame comprises a coaxial design with control surfaces;

[0042] FIG. 13(d) illustrates an aerial vehicle equipped with a gimbal system and an outer frame based on triangular structures forming modular components wherein an inner frame comprises a multi-rotor;

[0043] FIGS. 14(a) and 14(b) illustrate, respectively, an aerial vehicle according to the disclosure equipped with a gimbal system and tetrahedral bumpers protecting the outer frame wherein an inner frame comprises a coaxial design with control surfaces, and wherein an inner frame comprises a multi-rotor.

DETAILED DESCRIPTION

[0044] The present disclosure concerns a VTOL (vertical take-off and landing) aerial vehicle comprising an inner

frame, a gimbal system and an outer frame. The gimbal system reduces the disturbances provoked by a contact with an external object, allows rolling on obstacles and allows take-off from any orientation.

[0045] Only very little can be found in the literature about the analysis of collisions between aerial vehicles and external objects. Since the present disclosure concerns a system to reduce the disturbances from collisions, it is important to understand them. Typically, it is interesting to know how the aerial vehicle's linear and angular speeds are affected after an impact. A model developed in R. Cross, "Measurements of the horizontal coefficient of restitution for a superball and a tennis ball," *American Journal of Physics*, vol. 70, no. 5, p. 482, 2002, which is incorporated by reference herein in its entirety, describes the collisions of semi-elastic balls onto various types of surfaces, and can be adapted as described hereinafter to the case of aerial vehicles according to the disclosure after making certain assumptions.

[0046] Referring now to FIGS. 2(a) and 2(b), the instantaneous linear and angular speeds just before and just after the impact are studied. The case with a null angular speed just before the impact is considered for simplification reasons. It is assumed that there is only one contact point between the aerial vehicle and the external obstacle. Also, it is assumed that no other significant force than the contact force is applied on the aerial vehicle during the impact, in other words, the linear and angular accelerations generated by the propulsion and stabilization systems during the collision are considered to be negligible compared to the impact force. Finally, it is assumed that the collision can be studied in two dimensions on the collision plane **C 204**, which is defined as containing the contact point **P 207** and the initial velocity vector **v 208** whose origin is at the center of mass (COM) **203**. FIG. 2(a) shows an aerial vehicle equipped with a protective frame **201** colliding with an external object (beam) **202** at point **P**, and the collision plane **204** containing both **P 207** and **v 208**. The force **F 209** is the average force applied by the external object on the aerial vehicle during the impact and is assumed to be contained in **C**.

[0047] In the illustration of FIG. 2(a) the aerial vehicle is equipped with a protective frame **201** rigidly attached to the control and propulsion system colliding into the beam **202**. The collision plane **204** is defined as containing the contact point **P 207** and the initial velocity vector **v 208** whose origin is at the center of mass (COM) **203**. FIG. 2(b) illustrates a 2D representation of the aerial vehicle on the collision plane, whose coordinate system is defined with the origin at the contact point **P** and the **V** axis **206** pointing toward the COM. The **X** axis **205** is called the parallel or horizontal axis, and the **V** axis the perpendicular or vertical axis. The distance between the contact point **P** and the COM is **r 211**. The protective structure of the aerial vehicle is pictured as a circle **210**, but could be of any shape, just implying a variable **r** depending on the position of the contact point. The velocity **v' 212** and rotational velocity **w' 213** just after the collision are shown. The velocity after the impact **v' 212** is assumed to be contained in **C** and the angular speed vector after the impact **ω'** is assumed to be normal to **C** (only the rotation direction is pictured in **213**).

[0048] A collision of an aerial vehicle with an external obstacle can have very different outcomes, depending on the elasticity of the protective structure of the aerial vehicle, the friction with the obstacle, the rigidity of the obstacle, etc. Typically, the contact force will make the aerial vehicle

bounce away from the obstacle to some extent depending on the elasticity of the protective structure and the rigidity of the obstacle. While this disturbs the trajectory of the aerial vehicle, the biggest disturbance is the torque applied to the center of mass of the aerial vehicle, because it might reach an unstable orientation where the propulsion system is not generating a mostly upwards force anymore. Typically, if the initial velocity is not pointing towards the point of impact and the contact is not frictionless, the collision force at the point of impact generates a torque and thus provokes a certain amount of spin of the aerial vehicle depending on the friction between the protective structure and the obstacle.

[0049] While the dynamics of the interaction occurring during the impact are quite complicated and involve slipping, gripping or bouncing, the details can be ignored thanks to the introduction of two coefficients of restitution (COR), e_x and e_y :

$$e_y = -\frac{v'_y}{v_y} \quad (1)$$

$$e_x = -\frac{v'_x - r\omega'}{v_x} \quad (2)$$

[0050] The vertical COR e_y can vary between 0 and 1 and describes the amount of elasticity in the protective structure and external obstacle, and allows to determine how fast the aerial vehicle bounces off away from the obstacle. If e_y is equal to 1, the collision is fully elastic and the aerial vehicle will bounce off the wall with a reversed sign for the perpendicular speed while if e_y is equal to 0, the aerial vehicle will stay against the wall. The horizontal COR e_x can vary between -1 and 1 and describes the amount of friction between the protective structure and the external obstacle, as well as some elasticity, and allows to determine how much spin is given to the aerial vehicle. If e_x is equal to -1, it simulates a frictionless contact which doesn't generate any spin. If e_x is equal to 0, it simulates a contact where the aerial vehicle grips to the surfaces and the contact point comes to a rest, thus provoking a spin

$$\omega' = \frac{v'_y}{r}$$

If e_x is equal to 1, the contact point bounces back with opposite speed which provokes an even larger spin. While these coefficients are hard to obtain and vary from situation to situation, they allow to take a generic approach and generally don't need to be obtained to make most discussion points.

[0051] The velocity just after the impact v' , the angular speed just after the impact w' and the average contact force during the impact F can then be obtained knowing the velocity v just before the impact thanks to Newton's second law as such:

$$\omega' = v_x \frac{1}{r} \frac{(e_x + 1)}{(\alpha + 1)} \quad (3)$$

$$v'_x = v_x \frac{1 - \alpha e_x}{\alpha + 1} \quad (4)$$

-continued

$$v'_y = -e_y v_y \quad (5)$$

$$F_x = -\frac{mv_x}{\Delta t} \frac{\alpha}{\alpha + 1} (e_x + 1) \quad (6)$$

$$F_y = -\frac{mv_y}{\Delta t} (e_y + 1) \quad (7)$$

[0052] Where

$$\alpha = \frac{1}{mr^2}$$

is a scaleless parameter that describes the mass distribution of the aerial vehicle and is likely to be between 0.3 and 0.5 for conventional aerial vehicles of any size. I is the moment of inertia of the aerial vehicle about the axis normal to the collision plane at the center of mass **203**, m is the mass of the aerial vehicle, r **211** is the distance between the contact point **P 207** and the center of mass, and Δt is the duration of the impact.

[0053] It is interesting to note that w' **213** scales inversely proportionally to r which means that for similar aerial vehicles of different sizes colliding at the same speed with an external object, the rotation speed after a collision is larger for smaller aerial vehicles.

[0054] Also, the higher the moment of inertia I , the higher F_x will be and the smaller v'_x will be, meaning that for high moments of inertia, the aerial vehicle will experience a higher force and be slowed down more in the direction along the Y axis. Inversely, a lower moment of inertia reduces the friction force F_x which means the speed and aerial vehicle's trajectory will not be affected as much by the collision. In case of frictionless collision ($e_x = -1$), the rotational speed just after the impact w' is zero, as well as the friction force F_x .

[0055] An aerial vehicle according to the disclosure comprises an outer frame decoupled mechanically from an inner frame with a gimbal system, so that the outer frame can rotate passively around the inner frame. The inner frame contains the propulsion system and control system (for example one of those pictured in FIG. 1) that keep the aerial vehicle aloft by generating an upward force and rejecting small disturbances, while the outer frame prevents external objects from touching the inner frame and affecting its orientation. The gimbal system allows the outer frame to rotate passively around the inner frame about one or more rotation axes and it does not need to be actively actuated or controlled (e.g. with motors).

[0056] FIGS. 3(a) and 3(b) illustrate each main component of an aerial vehicle according to the disclosure comprising an inner frame **312**, a gimbal system **301** and an outer frame **304**, as well as the final assembly. The inner frame **312** comprising the propulsion and control systems are assembled inside two gimbals **302** and **303**, around which the outer frame **304** is mounted. The outer frame can rotate passively and freely around the inner frame around each of the **3** rotation axes **305**, **306** and **307**. The propulsion and control systems comprised in the inner frame could be of any type (for example one of those pictured in FIG. 1) and not necessarily the one pictured. Also, the outer frame can be any type of protective structure and not necessarily the one pictured.

[0057] A mechanism using two gimbals allowing for three degrees of rotation freedom is illustrated in FIGS. 3(a) and

3(b). The gimbal system 301 is comprised of three rotation axes 305, 306 and 307, three pairs of rotation joints 309, 310 and 311 and two gimbals 302 and 303. The first rotation axis 305 is created by the first pair of rotation joints 309, with each joint 309 aligned with each other and fixed in a position on opposite sides of the inner frame at the fixation points 313. The first pair of rotation joints 309 is also fixed in a position on opposite sides of the first gimbal 302. The second rotation axis 306 is created perpendicular to the first rotation axis 305 by the second pair of rotation joints 310, with each joint 310 aligned and fixed in a position on opposite sides of the first gimbal 302 and fixed in a position on opposite sides of the second gimbal 303 so the second rotation axis 306 is perpendicular to the first rotation axis 305. The third rotation axis 307 is created by the third pair of rotation joints 311, with each joint aligned and fixed in a position on opposite sides of the second gimbal 303 and on opposite sides of the outer frame 304 at fixation points 314 so the third rotation axis 307 is perpendicular to the second rotation axis 306. The rotation joints are mechanical parts allowing for full rotation between the two parts interfaced at the joint.

[0058] An embodiment of an aerial vehicle equipped with one gimbal allowing for two degrees of rotation freedom is shown in FIG. 4. This embodiment is particularly appropriate when the two rotation axes can be maintained in the horizontal plane before collisions (for example with one of the mechanisms presented further), so that the only constrained axis is around the yaw axis, around which the inner frame can rotate without severely affecting the stability of the platform, as disturbances in roll and pitch are the most serious for stability. In FIG. 4, an embodiment of an aerial vehicle is illustrated equipped with a gimbal system allowing the outer frame to rotate according to two rotation axes 305 and 306. The gimbal system uses one gimbal 302, and two pairs of rotation joints 309 and 310.

[0059] Reducing the Disturbances from Contacts with External Objects

[0060] On conventional aerial vehicles, the protective structure (if it exists) is rigidly attached to the propulsion and control systems. The contact with an external object will thus generate a torque and thus a rotation of the entire aerial vehicle, including the propulsion system, according to equation (3) above. This might have as strong impact on the ability of the aerial vehicle to remain stable in the air because the propulsion system might not generate a mostly upwards force anymore, and rather propel the aerial vehicle sideways while it loses altitude. However, decoupling the inner frame from the outer frame with a gimbal system allows the inner frame to remain independent of the rotation of the outer frame. The contact with an external object will thus generate a rotation of the outer frame, while the inner frame and the propulsion system remain in a stable orientation. FIGS. 5(a) and 5(b) show an example of a collision with an external obstacle 510, illustrating the differences between an aerial vehicle equipped with a gimbal system in FIG. 5(a) and a conventional aerial vehicle illustrated in FIG. 5(b). While FIGS. 5(a) and 5(b) show an example in 2 dimensions, the principle is the same in 3 dimensions for contacts anywhere on the outer frame.

[0061] FIGS. 5(a) and 5(b) illustrate a side view of two situations where an aerial vehicle collides with an external object. In FIG. 5(a) an example trajectory 501 is illustrated, of an aerial vehicle equipped with a gimbal system 507 decoupling the rotation of the outer frame 506 from the inner frame

508 and colliding with an obstacle 510. The aerial vehicle bounces off the obstacle because of the elasticity of the impact and is thus slightly diverted from its original trajectory. The outer frame 506 gains some angular speed 515 after the impact, but the inner frame 508 containing the propulsion and control systems stays in its original orientation, in which the propulsion system generates a lift force 513 mostly pointing upwards, and the aerial vehicle can thus continue towards the intended direction. FIG. 5(b) illustrates an example trajectory 503 of a conventional aerial vehicle, whose control and propulsion systems 511 are rigidly connected to a protective frame 512, colliding with an obstacle 510. The impact generates a torque 505 that rotates the aerial vehicle into an orientation in which the propulsion system generates a force 514 that is not pointing mostly upwards. The aerial vehicle thus loses lift and goes in the direction towards which the propulsion system is generating a force. In most situations, the control system is not able to stabilize the orientation of the aerial vehicle fast enough, which provokes a large perturbation in the trajectory, or even a crash to the ground. Assuming a gimbal system with no friction in the rotation joints comprising gimbals of negligible moment of inertia, only the moment of inertia of the outer frame needs to be considered in equations (3-7), since only the outer frame is rotating after a collision. This reduction of moment of inertia implies that the force F applied to the aerial vehicle is reduced and the aerial vehicle equipped with a gimbal system is not slowed down as much as a conventional aerial vehicle after a collision. The gimbal system thus helps not only to reduce the torque applied to the inner frame by external objects, but the force as well, thus helping the aerial vehicle go towards its intended direction without being slowed down as much. As illustrated in FIG. 6, the force F applied by the external object on the outer frame 601 of an aerial vehicle flying at speed v 609 equipped with a gimbal system 602 is transmitted to the inner frame 603 through each axis described in FIGS. 3(a) and 3(b), and the force vector F 608 has its origin at the crossing 605 of the rotation axes. If the center of mass of the inner frame 604 is misaligned with one or more of the axes, the center of mass experiences a torque $T=F \cdot d$ 607, with d 606 the distance between the force vector and the COM. To reduce the torque in order to minimize the disturbances affecting the inner frame's orientation, the COM should be aligned with all of the gimbal system's axes. In FIGS. 3(a) and 3(b), the COM should thus be at the crossing of the 3 axes.

[0062] FIG. 6 illustrates a side view of the aerial vehicle equipped with a gimbal system 602 colliding with an obstacle 610. The torque 607 generated at the center of mass 604 of the inner frame due to misalignment of the COM with respect to the gimbal system's rotation axes' crossing point 605 is pictured. The force 608 applied by the external object on the aerial vehicle equipped with a gimbal system is applied to the inner frame through the rotation axes of the gimbal system. The torque is proportional to the lever arm d 606, the distance between the force vector and the COM. To reduce the torque, d should be minimized.

[0063] After an impact, the outer frame rotates at an angular speed defined by equation (3), with a rotation axis perpendicular to the collision plane. The rotation of the outer frame lasts indefinitely if there is no friction in the passive joints of the gimbal system. If the COM of the outer frame is misaligned with respect to the crossing of the gimbal system's axes, rotation of the outer frame will generate a centrifugal force which might disturb the inner frame. This disturbance

can thus be minimized by aligning the COM of the outer frame with the crossing of the gimbal system's rotation axes.

[0064] When two axes of a gimbal system are aligned with each other, it loses a degree of freedom, and the inner frame is not fully decoupled from the outer frame anymore. This situation, called a gimbal lock, might prevent the gimbal system from reducing the disturbances from a contact with an external object, especially if a rotation axis in the horizontal plane is lost, as the pitch and roll axes are the most critical for keeping the lift force produced by the propulsion system mostly upwards. Solutions to this problem include: adding a gimbal or degree of freedom and/or actuating some gimbals to control their position away from a gimbal lock, adding repulsive or attractive elements like magnets in order to favor the position of the gimbals away from a gimbal lock. If using actuators, these should be reversible or capable of being turned off so that they allow free rotation with low friction when a collision happens.

[0065] An embodiment illustrated in FIG. 7 shows an aerial vehicle equipped according to the disclosure with a gimbal system whose gimbals **302** and **303** and outer frame **304** are equipped with magnets **701** to **703** to prevent the gimbals from reaching a gimbal lock position and/or to favor a certain relative orientation between the inner frame and the outer frame. In the embodiment, a disposition of magnets is illustrated, where a pair of magnets **701** is fixed to the first gimbal **302**, and another pair of magnets **702** is fixed to the second gimbal **303**. The north and south poles of magnets **701** and **702** are oriented so that they repulse each other, thus preventing the first and second gimbals to be in the same plane in the gimbal lock situation. In order to favor a certain relative orientation of the outer frame with respect to the inner frame, other magnets **703** can be fixed to the outer frame **304** so they are attracted to magnets **701**. The attraction should be tuned so the outer frame is sufficiently free to rotate in case of a contact with an external object to keep the torque on the inner frame low.

[0066] An embodiment illustrated in FIG. 8 shows an aerial vehicle equipped with a gimbal system and actuators **801**, **802** and **803** to control the rotation of the three rotation axes **305**, **306** and **307** respectively. The outer frame is equipped with an orientation sensor **810** as well as the control electronics **102**, which allows measurement of the relative orientation between the outer frame and the inner frame. The first actuator **801** can actuate the rotation of the first rotation axis **305**, the second actuator **802** can actuate the rotation of the second rotation axis **306** and the third actuator **803** can actuate the rotation of the third rotation axis **307**. In order to know the relative orientation between the outer frame and the inner frame, an orientation sensor **810** (e.g. an IMU) can be fixed to the outer frame and another orientation sensor can be included in the control electronics **102**, and the relative orientation can be obtained by correlating the signals from the two orientation sensors. Knowing the relative orientation of the outer frame with respect to the inner frame allows knowing the position of each gimbal, and thus allows generating adequate commands for the actuators.

[0067] Rolling on Obstacles

[0068] As mentioned above, the VTOL according to the disclosure allows the outer frame to stay in contact with an obstacle, be it below, sideways, or above the outer frame, and the VTOL may move with respect to the obstacle while staying in contact with it, which is described herein as "rolling on it." Referring now to FIG. 9. since the orientation of the inner

frame **903** is not constrained, the inner frame can move relative to the outer frame **901** to maintain appropriate lift and direction while the outer frame remains in constant contact with obstacles. This allows the aerial vehicle to roll on obstacles by controlling a motion towards any desired direction and keeping a component of the control force towards the obstacle in order to remain in contact. This is particularly useful to go around obstacles of complex shapes without the need for extra control to follow complex trajectories. FIGS. 9 and 10 show examples of such behaviors.

[0069] FIG. 9 illustrates a side-view of an aerial vehicle equipped with a gimbal system **902** that rolls on uneven ground **905** along a rightwards trajectory **904** by controlling a motion towards the right while maintaining a downwards force (e.g. by generating a lift force with the propulsion system that is lower than the take-off force) in order to remain in contact with the obstacle. While the inner frame **903** remains in the orientation controlled by the control system, the outer frame **901** rotates with a certain angular speed **906**.

[0070] FIG. 10 illustrates a top view of an aerial vehicle equipped with a gimbal system **1002** that rolls against vertical walls **1005** or obstacles **1007** by controlling a sideways motion towards the direction parallel to the walls, while remaining in contact with the obstacle by controlling a side force towards the obstacle. While the inner frame **1003** remains in the orientation controlled by the control system, the outer frame **1001** rotates with a certain angular speed **1006**. Such behavior allows the aerial vehicle to follow the contours of the environment, which is useful when looking for openings like a door **1009**. This behavior does not require complex control or sensing to be achieved, as it is enough to fly toward a direction (e.g. given by the magnetic direction **1008**).

[0071] While rolling against obstacles, using feedback from an orientation sensor **810** mounted on the outer frame allows control of the rolling speed as well as when the aerial vehicle is not rolling anymore because it is stuck in a local minima (e.g: corner).

[0072] Take-Off from Any Orientation

[0073] Referring now to FIGS. 11(a)-11(c), the system according to the disclosure is also useful to take-off from any orientation: when on the ground, the inner frame **1103** can rotate easily inside the outer frame **1101** as a function of the gimbal system **1102** and a mechanism can thus rotate the inner frame to an orientation appropriate for take-off. If the center of mass is placed at the crossing of the gimbal's rotation axes, the inner frame can be rotated in the desired orientation with minimal torques (just enough to overcome the friction in the gimbal system). The control system of the inner frame can typically be used to rotate the inner frame in a take-off orientation.

[0074] FIG. 11(a) illustrates an aerial vehicle equipped with a gimbal system **1102** resting on the ground **1105** at an orientation not appropriate for take-off. Therefore it uses its control system to generate enough torque τ **1104** to rotate the inner frame **1103** to a vertical orientation while the outer frame remains static. FIG. 11(b) illustrates the aerial vehicle ready to take-off because the propulsion system is in an orientation where it is able to generate a force pointing upwards. FIG. 11(c) illustrates the propulsion system generates a vertical thrust **T** **1106** which makes the aerial vehicle take-off.

[0075] Protective Structures

[0076] The outer frame should prevent external objects from touching the inner frame or the gimbal system and should not strongly affect the propulsion system, typically by obstructing the airflow. In addition, while remaining lightweight the outer frame should be able to absorb collision energy without breaking, and it should be stiff enough to protect the gimbal system and inner frame but flexible enough to reduce the peak contact force, and thus the strain on the rest of the system. Three different designs for the outer frame are illustrated in FIGS. 12(a), 12(b) and 12(c).

[0077] The first design for the outer frame shown in FIG. 12(a) is based on beams 1201 fixed to each other at connecting points 1202, and arranged so that each beam defines an edge of a spherical polyhedron. When a force is applied on a spherical polyhedron, the load is shared among all the beams of the structure. Such a structure is thus able to absorb a relatively high collision energy for its weight. Also, the numerous beams prevent most external objects from touching the gimbal system or the inner frame. Finally, the spherical shape is advantageous for rolling on obstacle.

[0078] The second design for the outer frame shown in FIG. 12(b) is based on a relatively stiff base 1203 on which tetrahedral structures made of three flexible beams 1204 are mounted with pivot joints 1205 and 1206 to act as elastic bumpers that absorb the collision energy. The tetrahedral arrangement allows at least one of the beam to work in buckling mode when a force is applied on the structure. Buckling allows maximizing the energy a single beam can absorb, because the deformation force is close to maximal from the beginning to the end of the deformation.

[0079] A third outer frame design is illustrated in FIG. 12(c). This design is based on triangle structures 1220 which can be readily mass produced and assembled. Lightweight composite clips 1222 are used to assemble the sides of the triangles. The triangles may be pre-assembled into a plurality of sub-assemblies, pentagons or hexagons, that may be packaged as a kit for ease of storage and transport. The sub-assemblies may be assembled into the outer frame for housing the structures of the VTOL described hereinbefore.

[0080] FIG. 12(a) illustrates an example of a protective outer frame based on beams 1201 outlining a spherical polyhedron, in particular a truncated icosahedron in this case. Such a frame allows appropriate stiffness with minimal weight. FIG. 12(b) illustrates an example of a protective outer frame using tetrahedral bumpers made of three flexible beams 1204 attached to a rigid base 1203 with pivot joints 1205 and 1206 to provide flexibility. Thanks to the tetrahedral arrangement, the beams work in buckling mode which allows maximized energy absorption for a given beam.

[0081] FIG. 12(c) illustrates a configuration that is relatively easily mass produced and packaged as sub-assemblies for ease of storage and transportation, and packaging as a kit for easy assembly.

[0082] Aerial Vehicles

[0083] For a given payload to carry, the optimal choice for the propulsion system is generally the one with the best lift force to area ratio, because the size of the propulsion system will determine the size, thus the weight of the gimbal system and the outer frame, which should be minimized. Typically, coaxial configurations like the ones presented in FIGS. 1(c) and (d) have a good lift force to area ratio.

[0084] Embodiments shown in FIGS. 13(a) through 13(d) and 14(a) and 14(b) show examples of aerial vehicles equipped with the protective structures described above.

[0085] FIGS. 13(a) and 13(b) illustrate aerial vehicles equipped with a gimbal system and a spherical polyhedron as outer frame. FIG. 13(a) illustrates an inner frame comprises a coaxial design with control surfaces. FIG. 13(b) illustrates an inner frame comprises a multi-rotor. FIGS. 13(c) and 13(d) illustrate aerial vehicles with triangle structures and clips forming modular components for the outer frame. FIG. 13(c) illustrates an aerial vehicle equipped with a gimbal system and an outer frame based on triangular structures forming modular components wherein an inner frame comprises a coaxial design with control surfaces. FIG. 13(d) illustrates an aerial vehicle equipped with a gimbal system and an outer frame based on triangular structures forming modular components wherein an inner frame comprises a multi-rotor.

[0086] FIGS. 14(a) and 14(b) illustrate aerial vehicles equipped with a gimbal system and tetrahedral bumpers protecting the outer frame. FIG. 14(a) illustrates an inner frame comprising a coaxial design with control surfaces, while FIG. 14(b) illustrates an inner frame comprising a multi-rotor.

[0087] Although the devices, systems, and methods have been described and illustrated in connection with certain embodiments, many variations and modifications will be evident to those skilled in the art and may be made without departing from the spirit and scope of the disclosure. The discourse is thus not to be limited to the precise details of methodology or construction set forth above as such variations and modification are intended to be included within the scope of the disclosure.

What is claimed is:

1. A vertical take-off and landing (VTOL) aerial vehicle comprising an inner frame, a gimbal system and an outer frame, said inner frame comprising a propulsion system and a control system, said propulsion system configured to generate a lift force, said control system configured to control the orientation of the inner frame, said gimbal system connecting the inner frame to the outer frame with at least two rotation axis allowing rotation freedom between the outer frame to rotate independently from the inner frame, the inner frame having a center of mass that is substantially in alignment with each rotation axis.

2. The VTOL aerial vehicle of claim 1, wherein the at least two rotation axes comprise a first rotation axis and a second rotation axis and the second rotation axis is substantially perpendicular to the first rotation axis.

3. The VTOL aerial vehicle of claim 1, wherein the at least two rotation axes comprise a first rotation axis, a second rotation axis and a third rotation axis and wherein the second rotation axis is substantially perpendicular to the first rotation axis and the third rotation axis is substantially perpendicular to the second rotation axis.

4. The VTOL aerial vehicle of claim 1, wherein the rotation axes are crossing.

5. The VTOL aerial vehicle of claim 1, wherein the gimbal system comprises three rotation axes, three pairs of rotation joints and two gimbals, said first rotation axis created by said first pair of rotation joints, each of said first pair of rotation joints aligned with each other and fixed on opposite sides of the inner frame and on opposite sides of the first gimbal, said second rotation axis created by said second pair of rotation joints, each of said second pair of rotation joints aligned and fixed on opposite sides of the first gimbal and on opposite

sides of the second gimbal so said second rotation axis is perpendicular to said first rotation axis, said third rotation axis created by said third pair of rotation joints, each of said third pair of rotation joints aligned and fixed on opposite sides of the second gimbal and on opposite sides of the outer frame so said third rotation axis is perpendicular to said second rotation axis, each of said first pair of rotation joints and said second pair of rotation joints and said third pair of rotation joints allowing for full rotation of parts attached to said first pair of rotation joints and said second pair of rotation joints.

6. The VTOL aerial vehicle of claim 1, wherein the outer frame is made of beams connected to each other and arranged so that each beam defines an edge of a spherical polyhedron or a truncated icosahedron.

7. The VTOL aerial vehicle of claim 1, wherein the outer frame is made of a stiff structure, and elastic bumpers, said elastic bumpers comprising at least three flexible beams fixed to at least three different points of the stiff structure, each flexible beam being fixed to the stiff structure with a pivot joint on one end and connected to the other flexible beams with pivot joints on the other end, such that the flexible beams describe a pyramid shape.

8. The VTOL aerial vehicle of claim 1, wherein the outer frame is configured with an orientation sensor.

9. The VTOL aerial vehicle of claim 1, wherein the outer frame can be actively rotated to a desired orientation with respect to the inner frame using one or more actuators.

10. The VTOL aerial vehicle of claim 8, wherein the orientation sensor is used to control the orientation of the outer frame in any desired orientation.

11. The VTOL aerial vehicle of claim 9, wherein the one or more actuators are configured to control the orientation of the outer frame in any desired orientation.

12. The VTOL aerial vehicle of claim 1, further comprising magnets and wherein the outer frame's orientation with respect to the inner frame is affected by said magnets, said magnets positioned on the outer frame and inner frame to attract or reject each other when getting close to each other.

13. The VTOL aerial vehicle of claim 1, wherein the orientation of the outer frame is configured with active control that keeps at least one rotation axis of the gimbal system from becoming aligned with another.

14. The VTOL aerial vehicle of claim 1, wherein the outer frame is made of triangle structures and clips and individual triangle structures are pre-assembled into subassemblies that are configured to be assembled to form the outer frame.

15. A vertical take-off and landing (VTOL) aerial vehicle comprising

an inner frame, said inner frame comprising a propulsion system and a control system, said propulsion system configured to generate a lift force, said control system configured to control the orientation of the inner frame,

a gimbal system, said gimbal system connecting the inner frame to the outer frame with at least two rotation axis allowing rotation freedom between the outer frame to rotate independently from the inner frame, the inner frame having a center of mass that is substantially in alignment with each rotation axis, the gimbal system having rotation joints;

an outer frame made of a stiff structure and a plurality of beams configured to protect the inner frame and gimbal system during flight of the vertical take-off and landing aerial vehicle, and the outer frame configured with fixation points aligned and engaged with the rotation joints

of the gimbal system so the outer frame rotates passively and freely around the inner frame and gimbal system.

16. The VTOL aerial vehicle of claim 15, wherein the gimbal system comprises three rotation axes, three pairs of rotation joints and two gimbals, said first rotation axis created by said first pair of rotation joints, each of said first pair of rotation joints aligned with each other and fixed on opposite sides of the inner frame and on opposite sides of the first gimbal, said second rotation axis created by said second pair of rotation joints, each of said second pair of rotation joints aligned and fixed on opposite sides of the first gimbal and on opposite sides of the second gimbal so said second rotation axis is perpendicular to said first rotation axis, said third rotation axis created by said third pair of rotation joints, each of said third pair of rotation joints aligned and fixed on opposite sides of the second gimbal and on opposite sides of the outer frame so said third rotation axis is perpendicular to said second rotation axis, each of said first pair of rotation joints, said second pair of rotation joints and said third pair of rotation joints allowing for full rotation of parts attached to said first pair of rotation joints, said second pair of rotation joints and said third pair of rotation joints.

17. The VTOL aerial vehicle of claim 15, wherein one or more actuators are used to control the orientation of the outer frame in any desired orientation.

18. A vertical take-off and landing (VTOL) aerial vehicle comprising

an inner frame, said inner frame comprising a propulsion system and a control system, said propulsion system configured to generate a lift force, said control system configured to control the orientation of the inner frame;

an outer frame made of a stiff structure and a plurality of beams configured to protect the inner frame during flight of the vertical take-off and landing aerial vehicle, the outer frame configured to rotate passively and freely around the inner frame;

a gimbal system interior to the outer frame and being protected by the outer frame, said gimbal system connecting the inner frame to the outer frame, said gimbal system comprising a first gimbal and a first rotation axis created by a first pair of rotation joints, each of said first pair of rotation joints aligned with each other and fixed on opposite sides of the inner frame and on opposite sides of the first gimbal, a second gimbal and a second rotation axis created by a second pair of rotation joints, each of said second pair of rotation joints aligned and fixed on opposite sides of the first gimbal and on opposite sides of the second gimbal so said second rotation axis is perpendicular to said first rotation axis, each of said first pair of rotation joints and said second pair of rotation joints allowing for full rotation of parts attached to said first pair of rotation joints and said second pair of rotation joints.

19. The VTOL aerial vehicle of claim 18 wherein the inner frame has a center of mass that is substantially in alignment with each rotation axis, and orientation of the outer frame is actively controlled so no rotation axis of the gimbal system is aligned with another.

20. The VTOL aerial vehicle of claim 18 wherein the outer frame is made of triangle structures individual triangle structures are pre-assembled into subassemblies that are configured to be assembled to form the outer frame.