



(19) **United States**

(12) **Patent Application Publication**
Kurata et al.

(10) **Pub. No.: US 2020/0047503 A1**

(43) **Pub. Date: Feb. 13, 2020**

(54) **INKJET PRINTING APPARATUS**

(52) **U.S. Cl.**

(71) Applicant: **CANON KABUSHIKI KAISHA,**
Tokyo (JP)

CPC **B41J 2/16505** (2013.01); **B41J 2202/19**
(2013.01); **B41J 2202/14** (2013.01)

(72) Inventors: **Tetsuji Kurata,** Yokohama-shi (JP);
Takuya Iwano, Inagi-shi (JP);
Hiromasa Amma, Kawasaki-shi (JP)

(57) **ABSTRACT**

(21) Appl. No.: **16/531,765**

An inkjet printing apparatus includes a print head, to which a protective member configured to protect an ejection opening surface is attachable, and a head holder configured to hold the print head detachably. The inkjet printing apparatus further includes a guide portion provided in the head holder and configured to guide, in a width direction, the print head with the ejection opening surface protected by the protective member. The guide portion guides the print head with the protective member attached up to a predetermined position in the width direction and guides only the print head ahead of the predetermined position to prevent the protective member from exceeding the predetermined position.

(22) Filed: **Aug. 5, 2019**

(30) **Foreign Application Priority Data**

Aug. 10, 2018 (JP) 2018-151445

Publication Classification

(51) **Int. Cl.**
B41J 2/165 (2006.01)

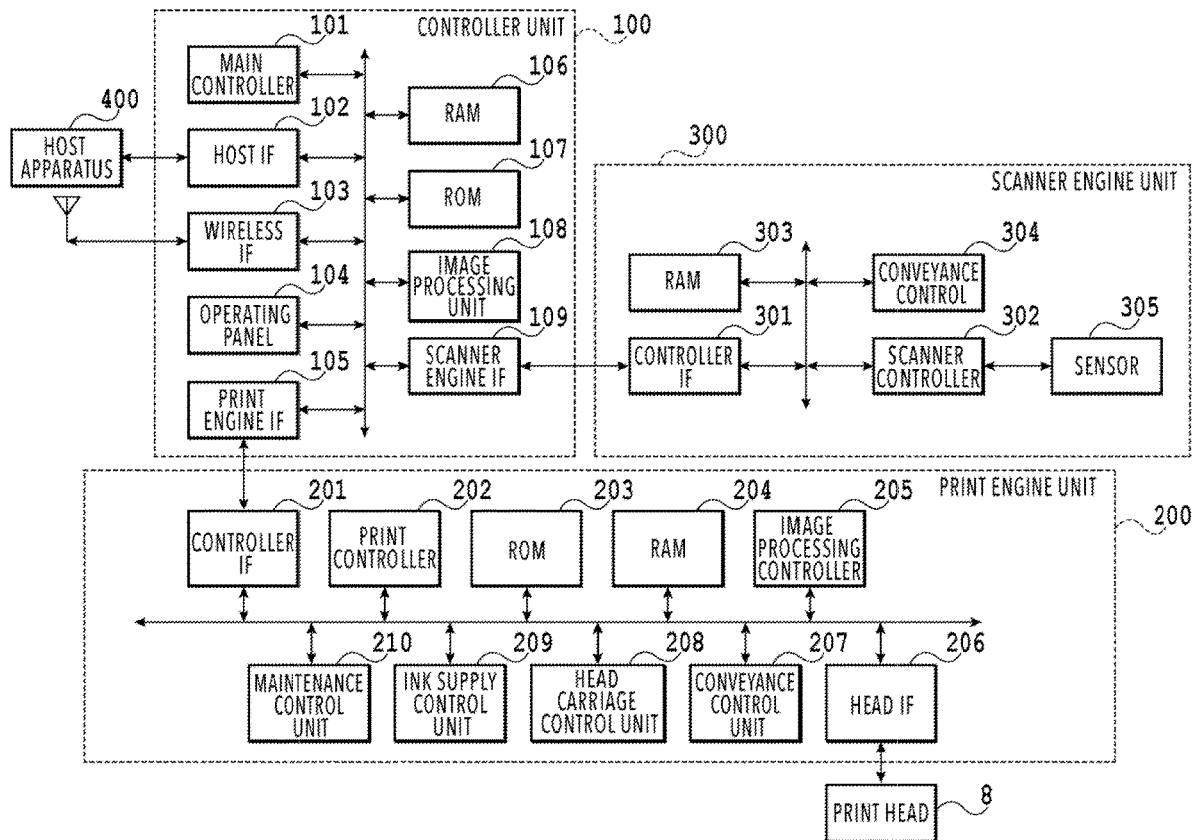

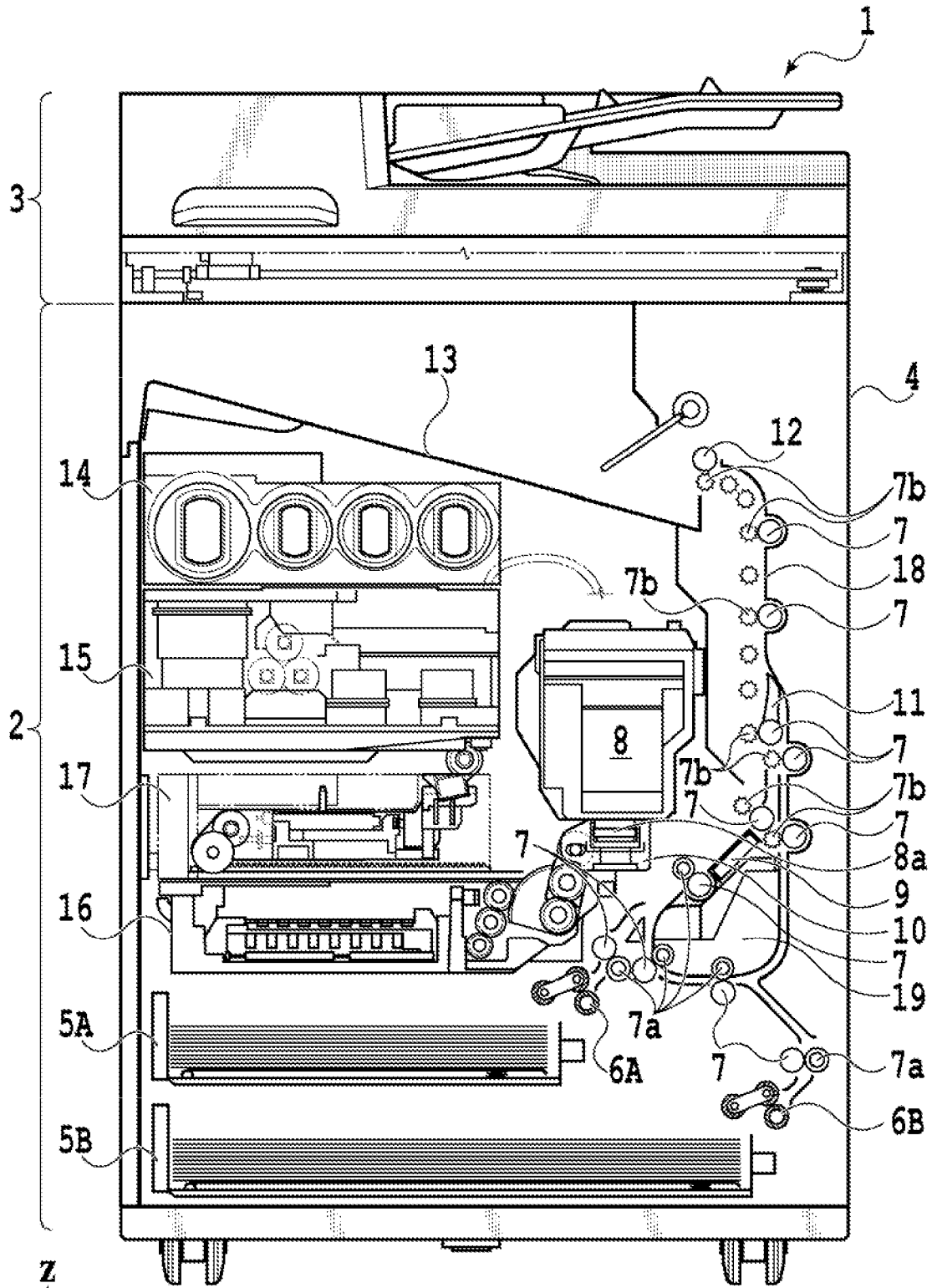

FIG.1

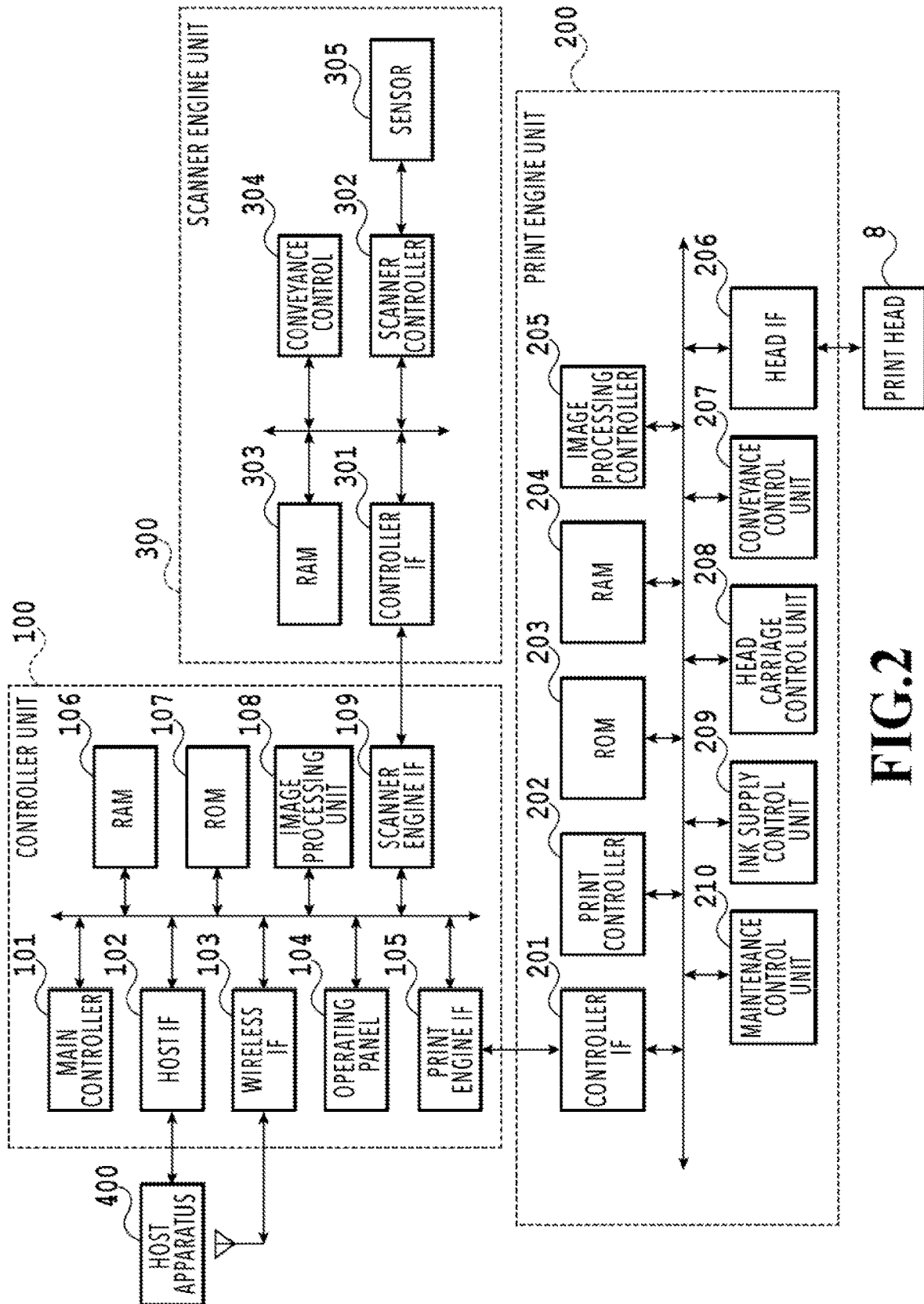

FIG. 2

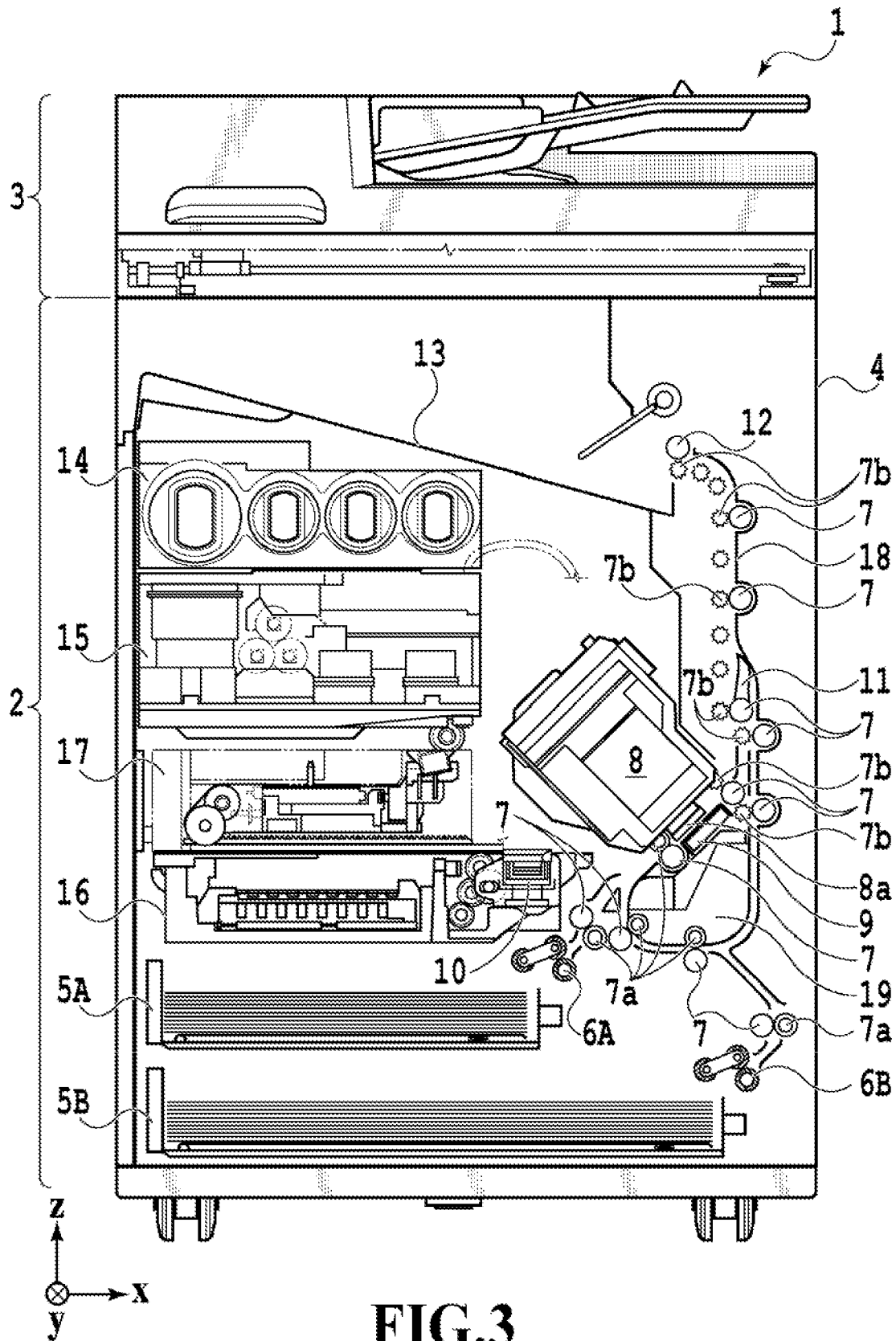

FIG. 3

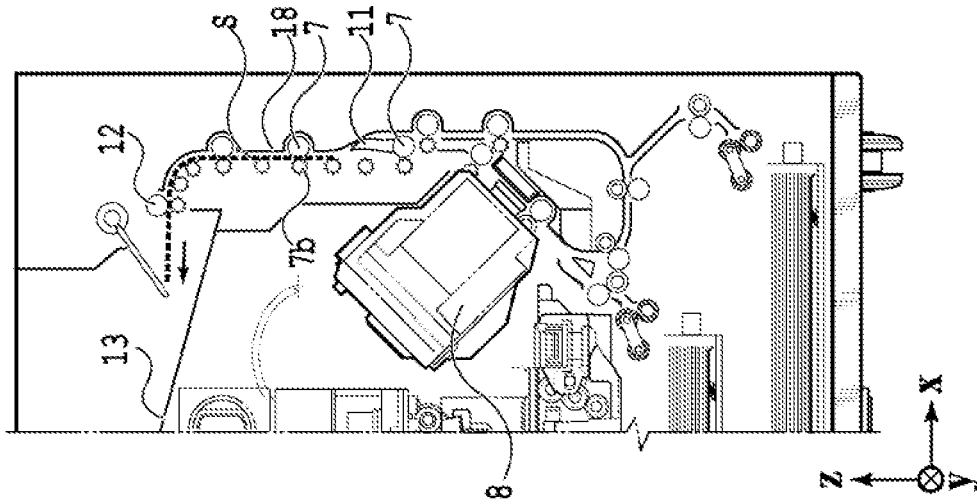

FIG.4C

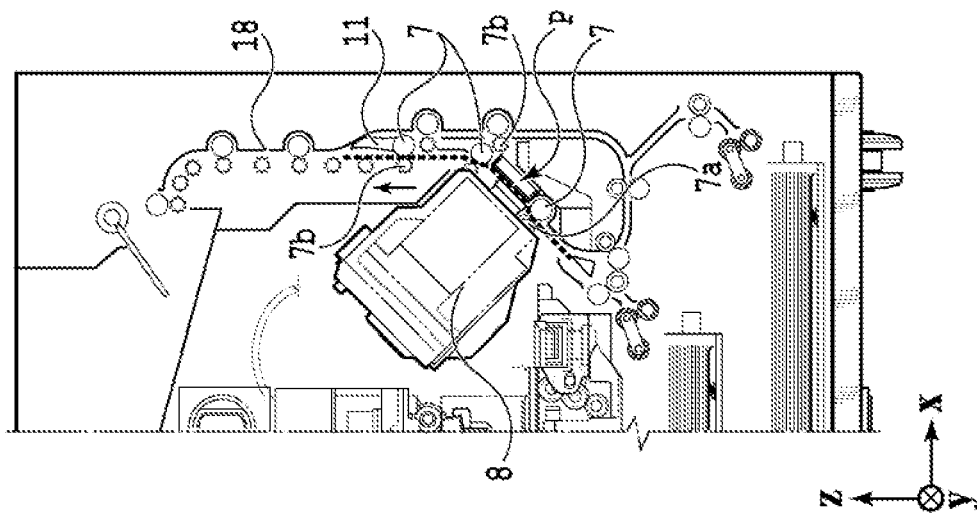

FIG.4B

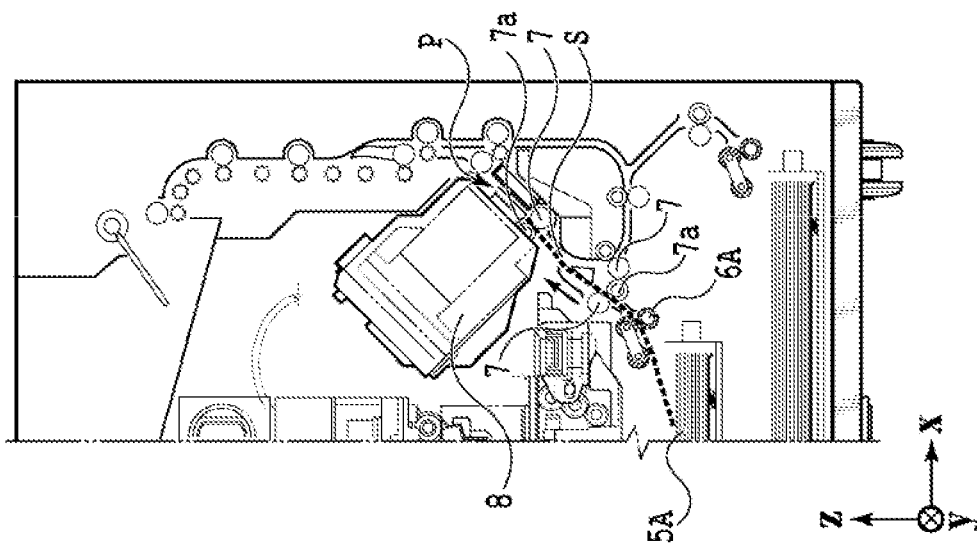

FIG.4A

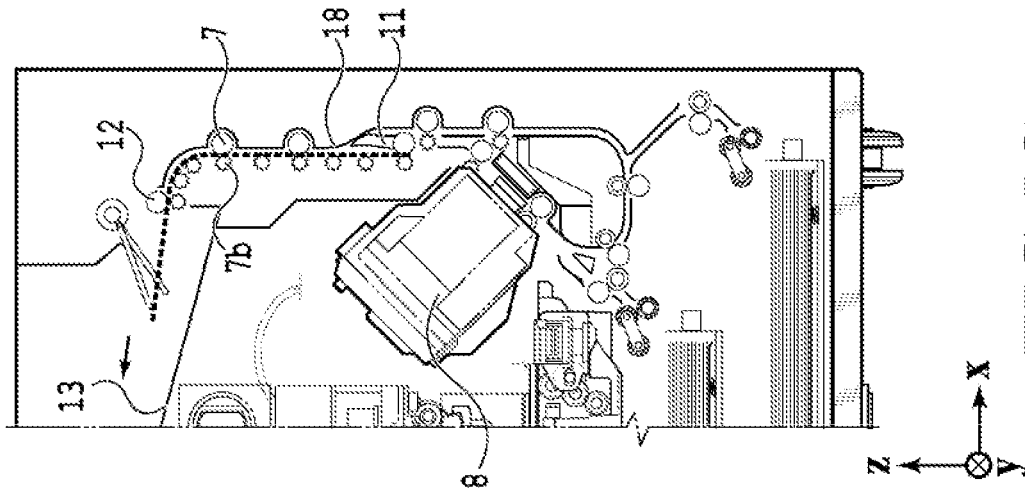

FIG.5A

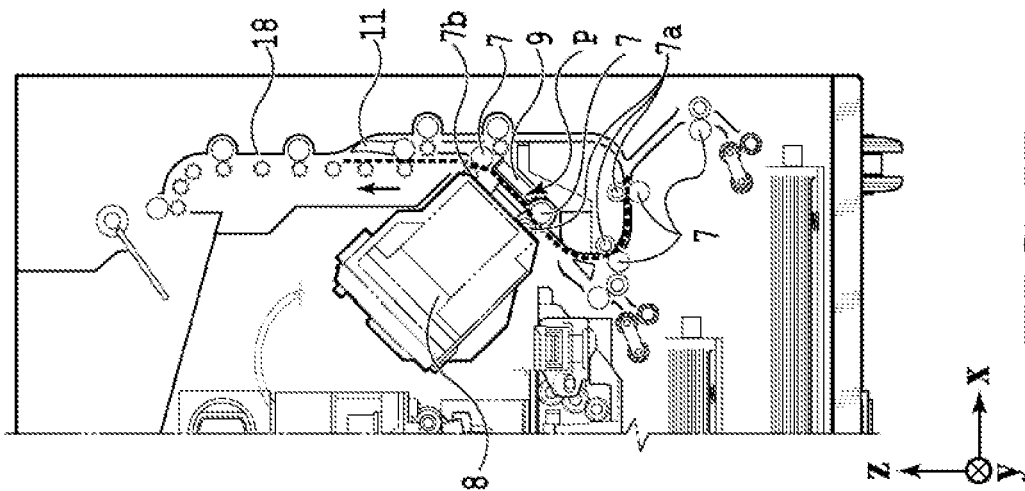

FIG.5B

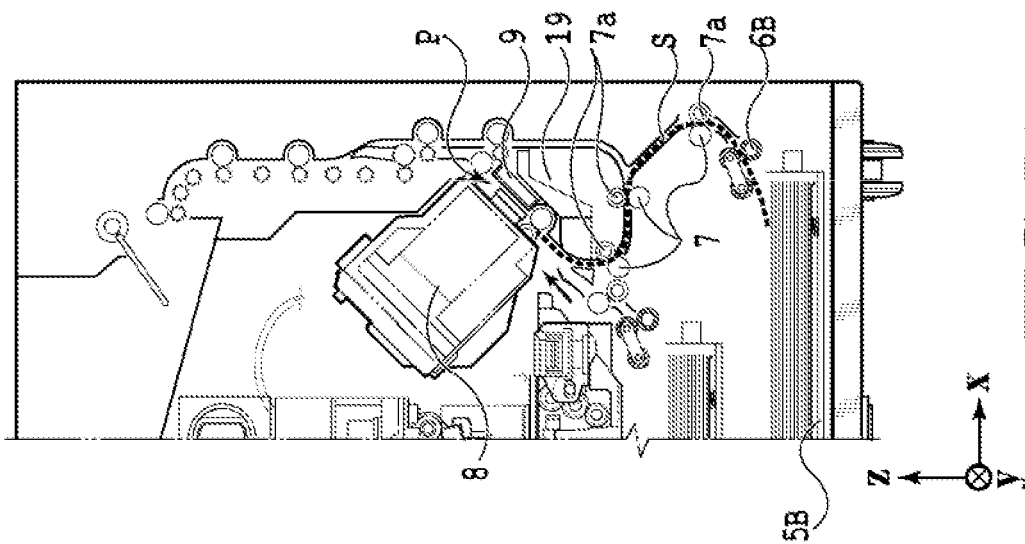

FIG.5C

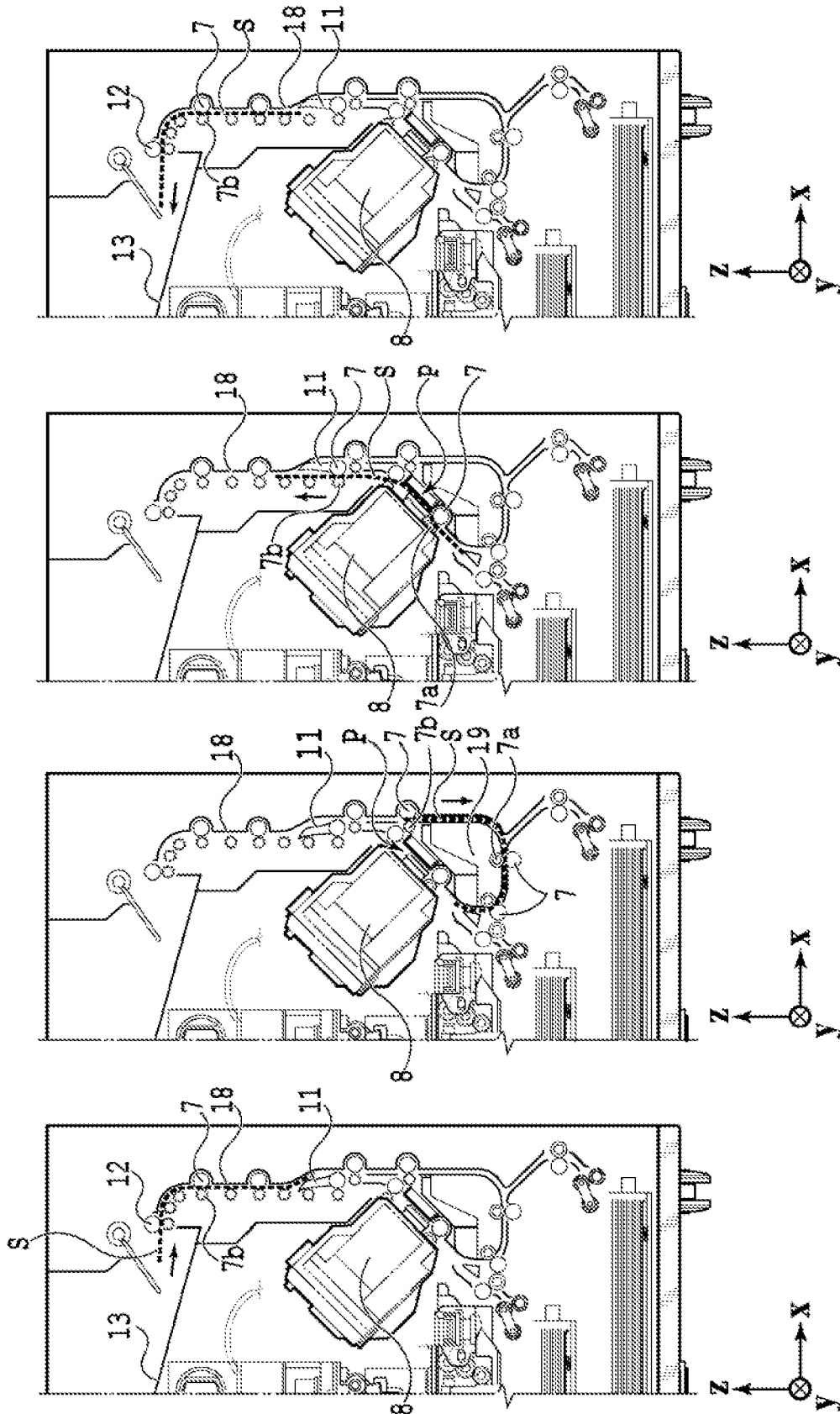

FIG. 6D

FIG. 6C

FIG. 6B

FIG. 6A

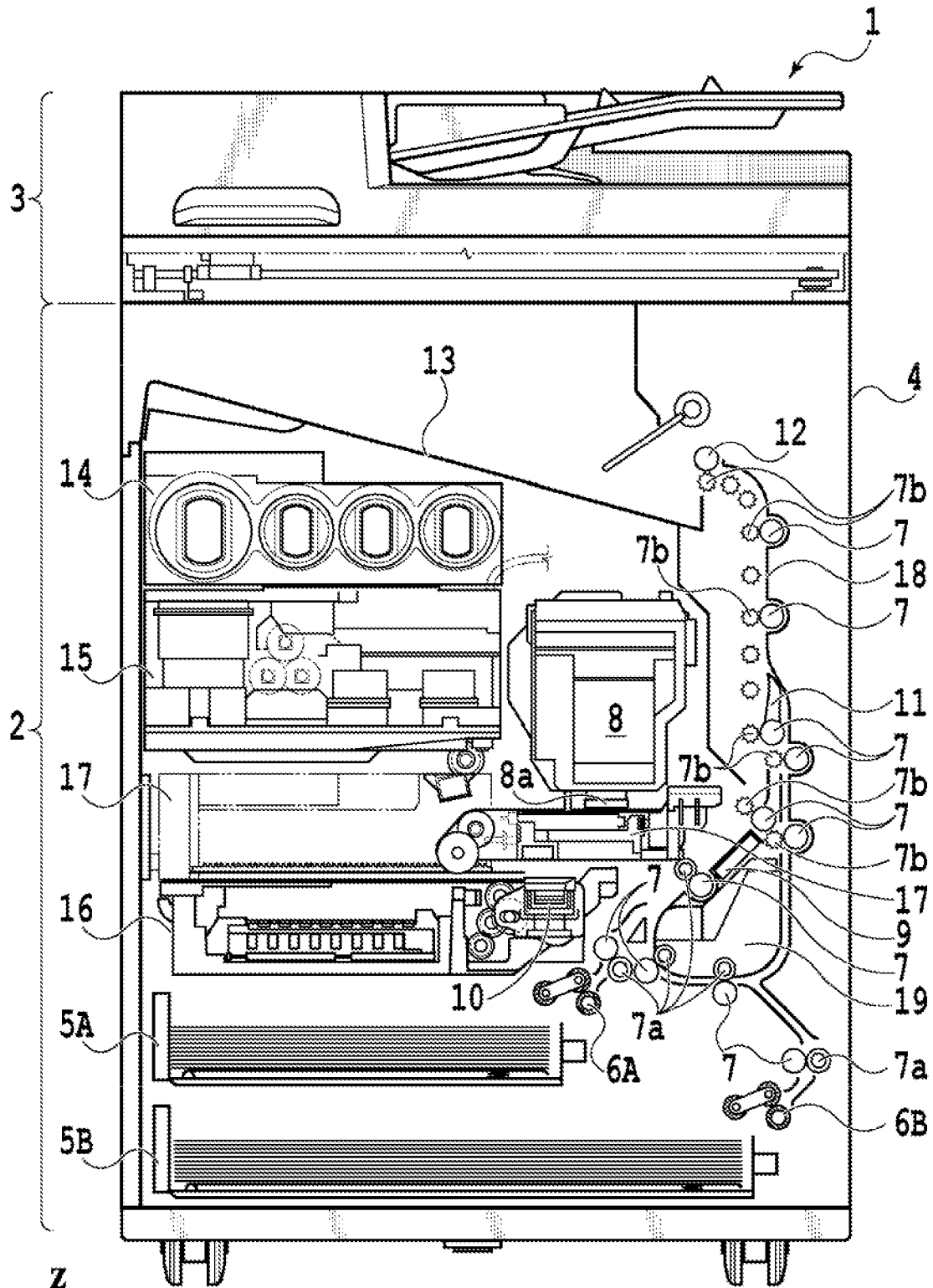

FIG. 7

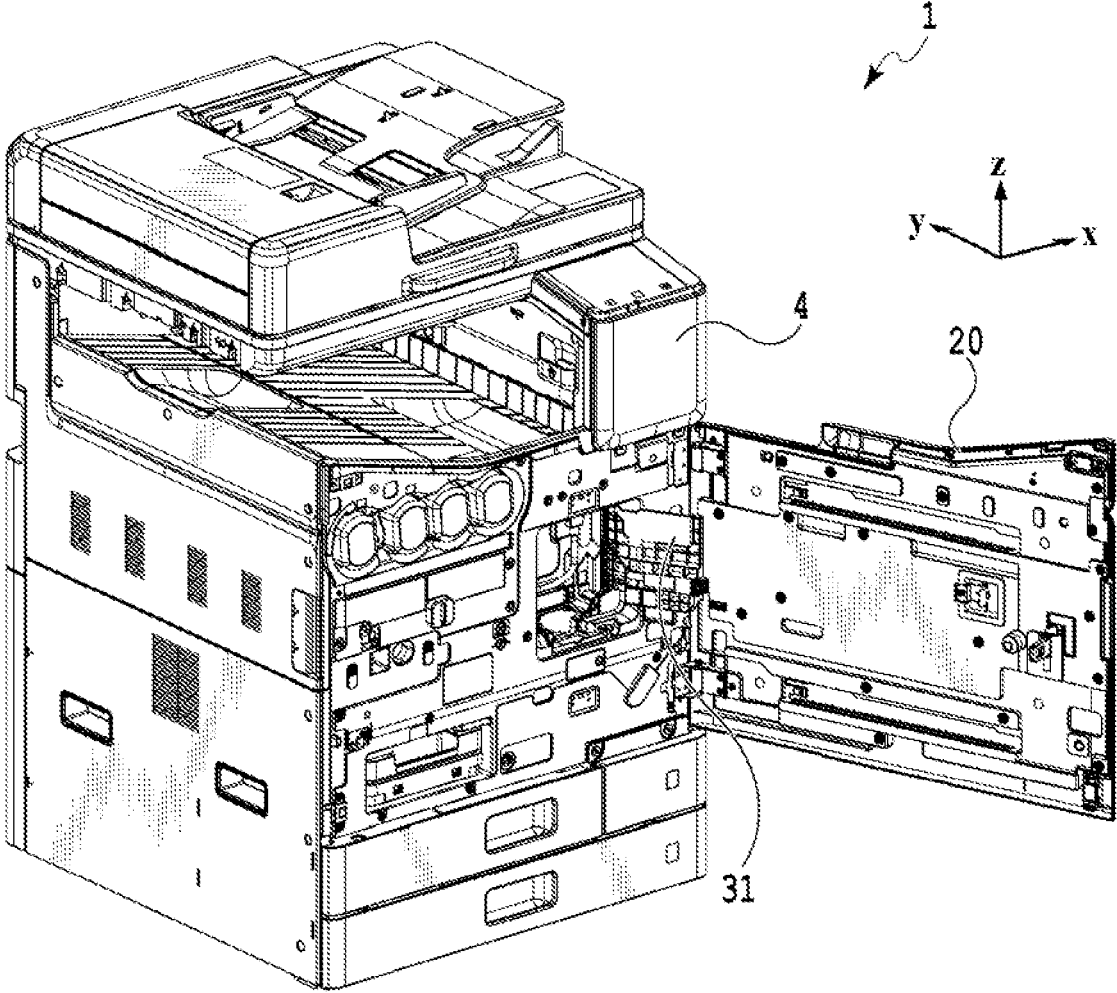

FIG.8

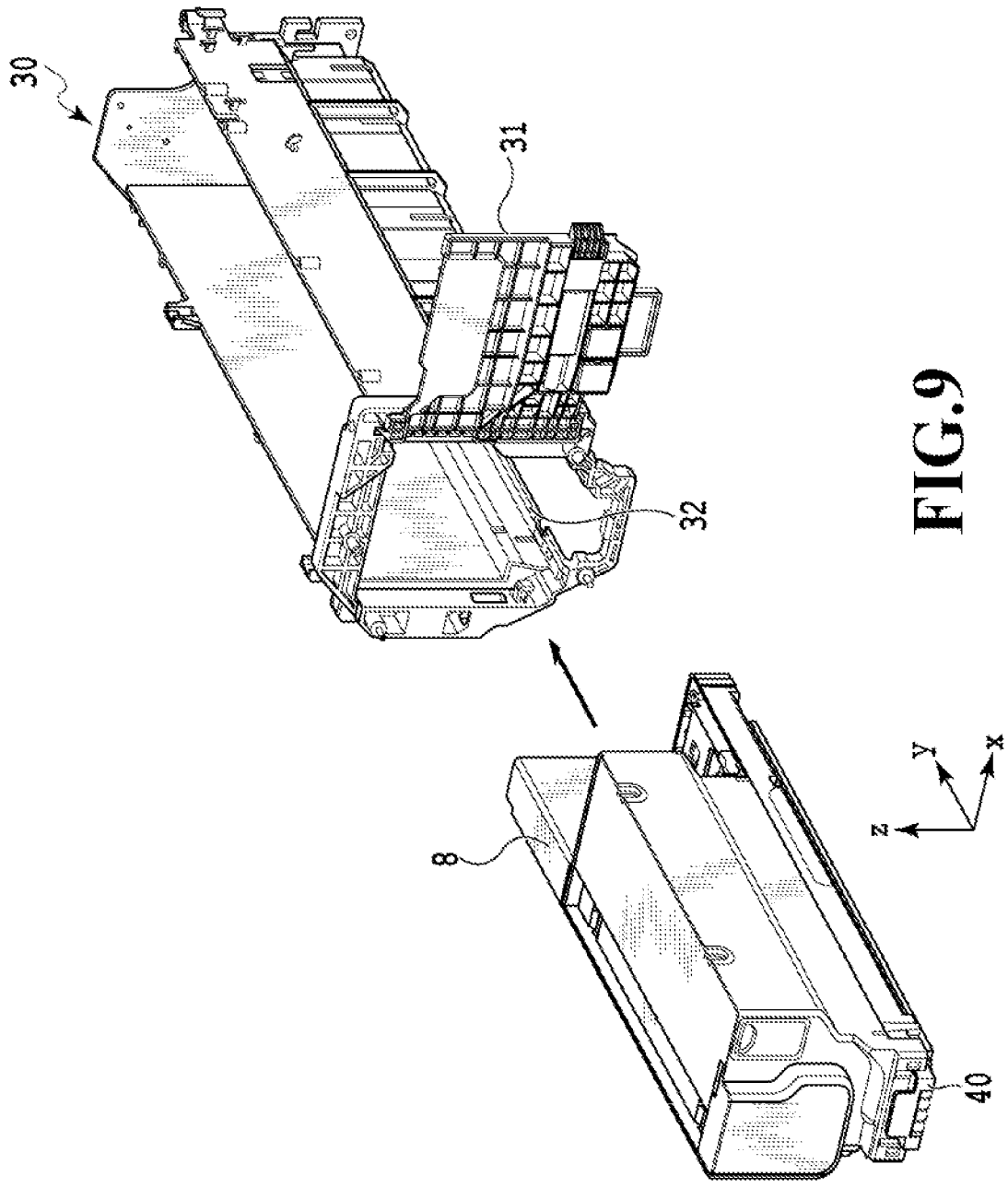

FIG.9

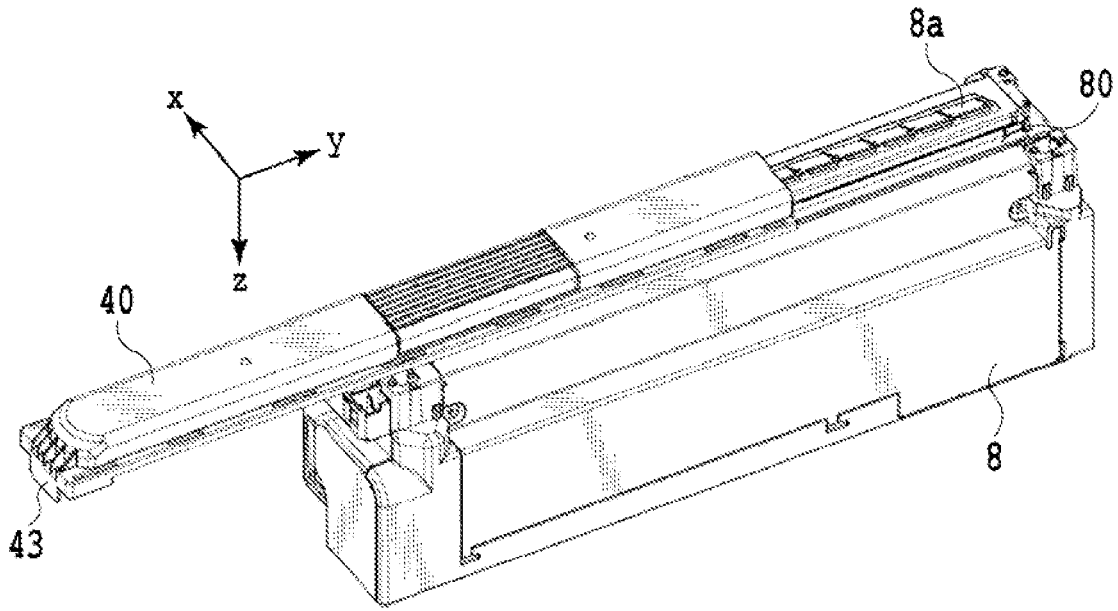

FIG. 10A

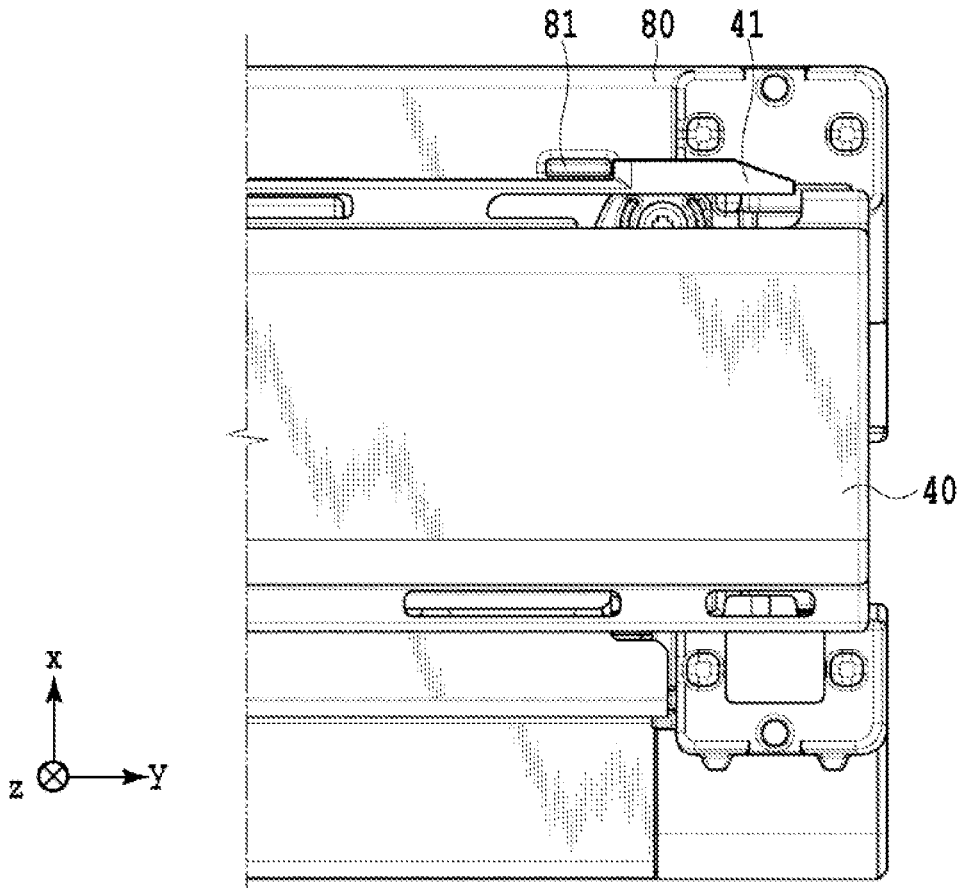

FIG. 10B

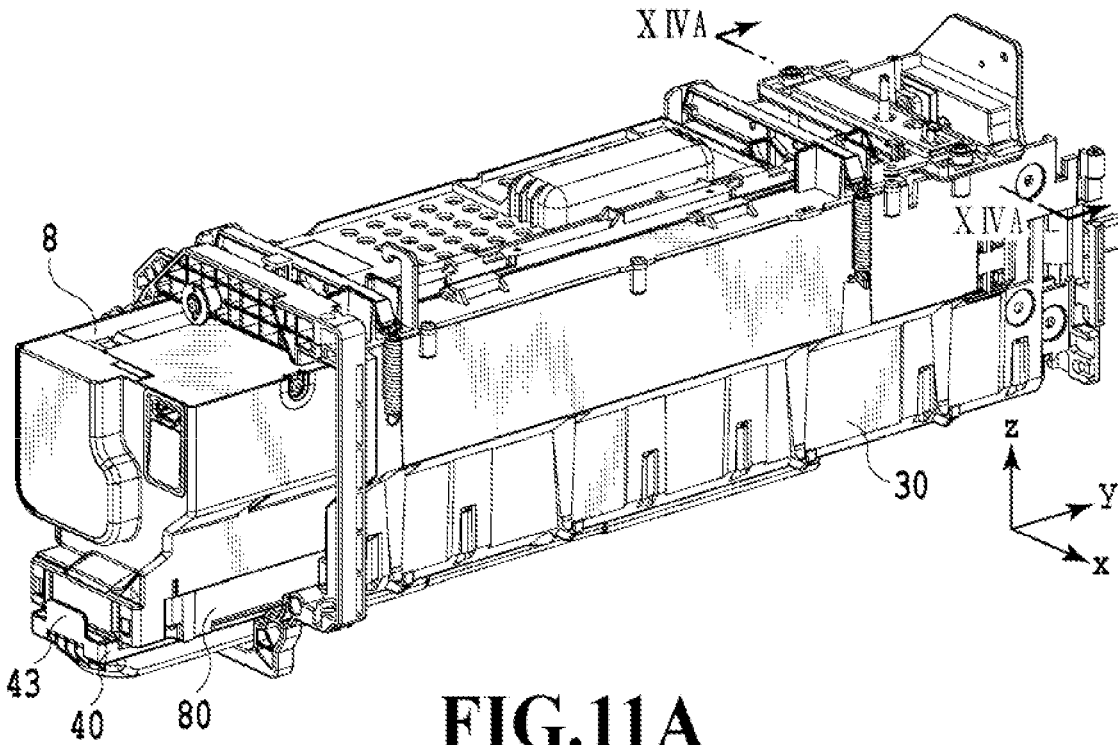

FIG. 11A

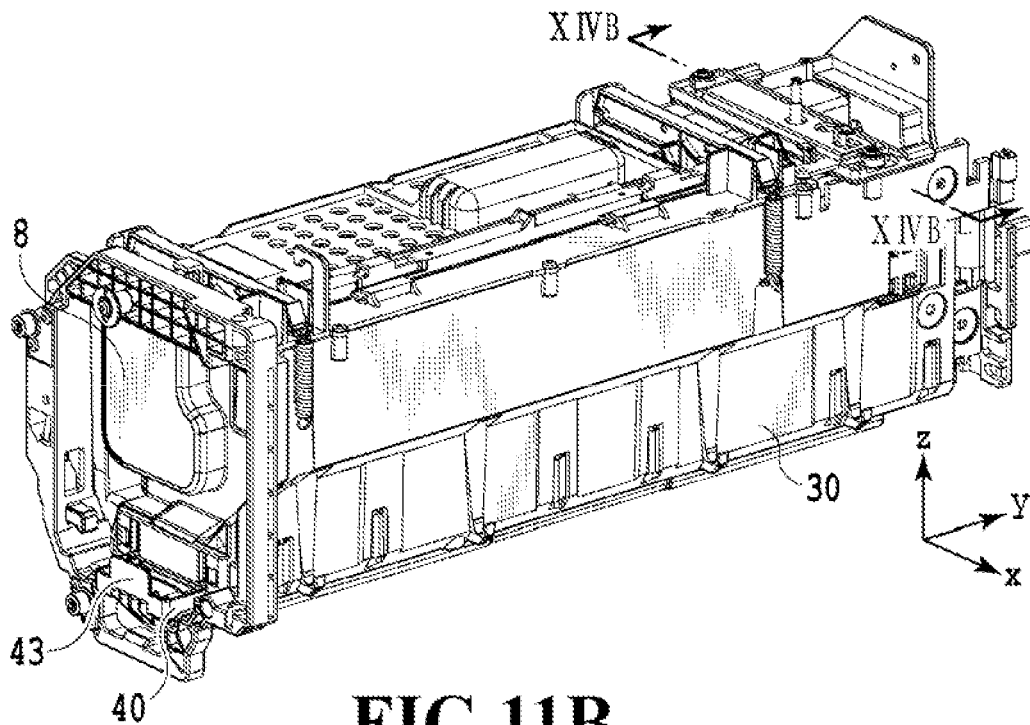
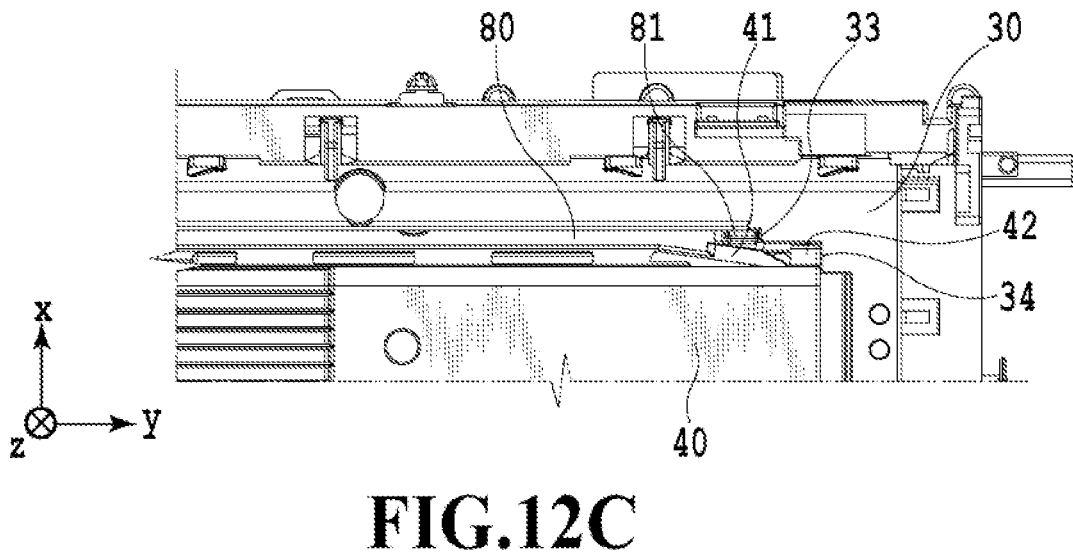
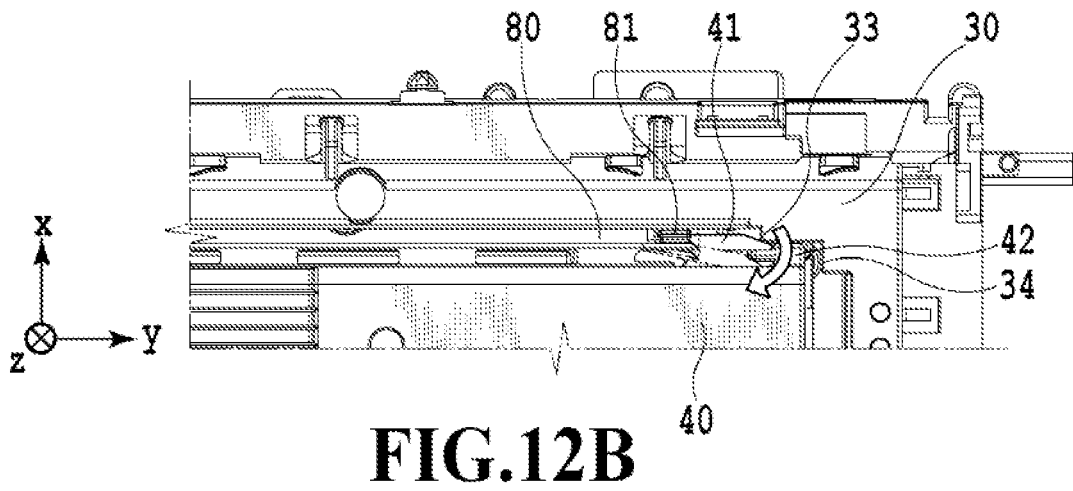
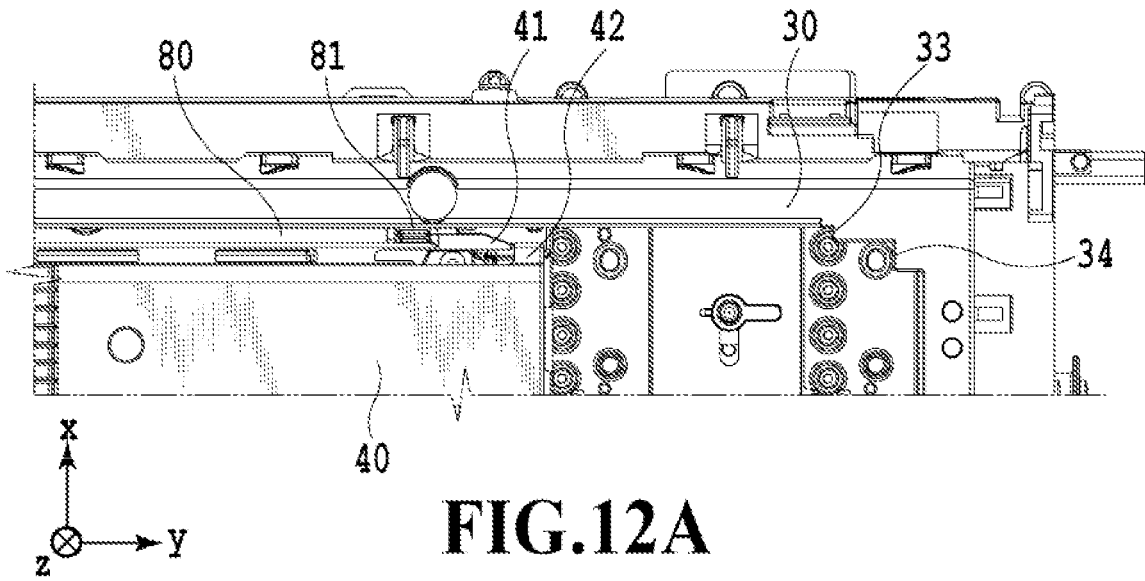

FIG. 11B



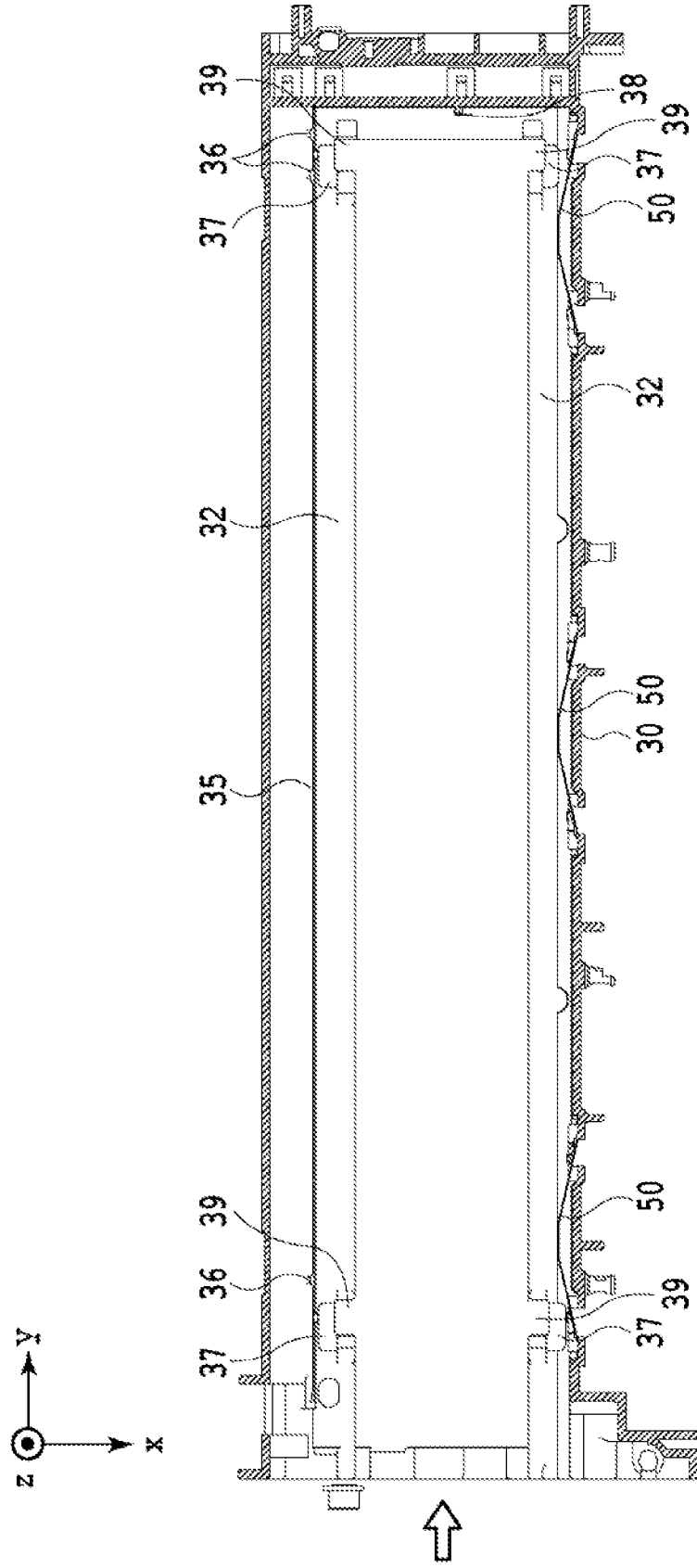

FIG. 13

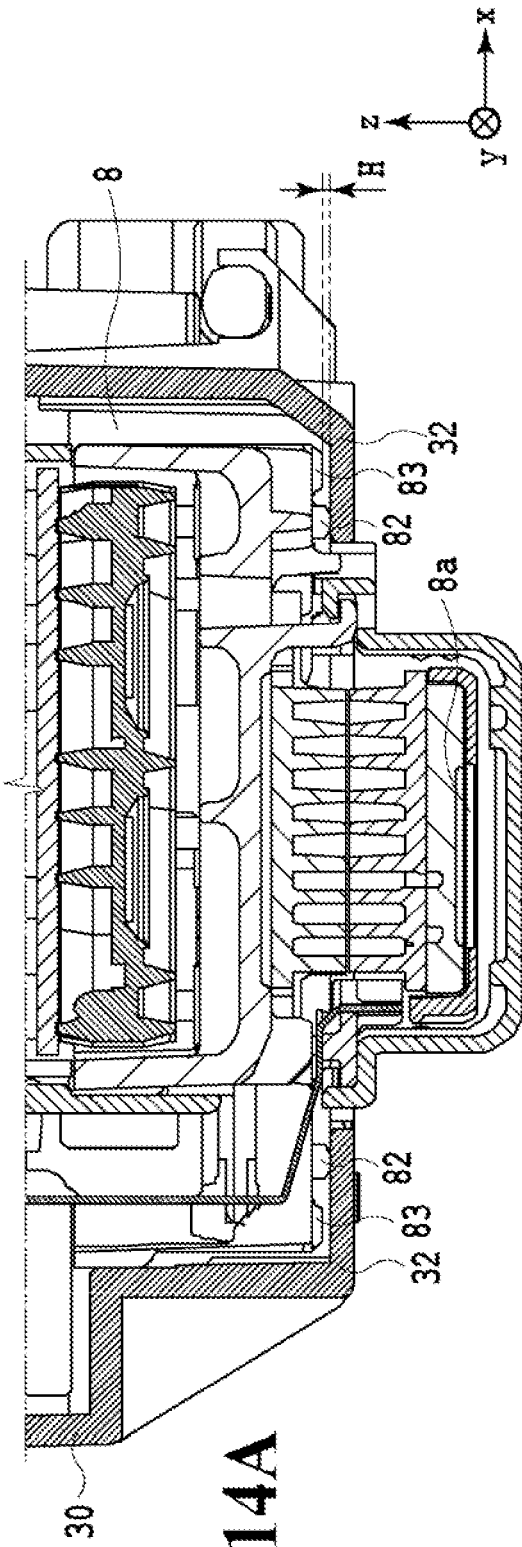

FIG. 14A

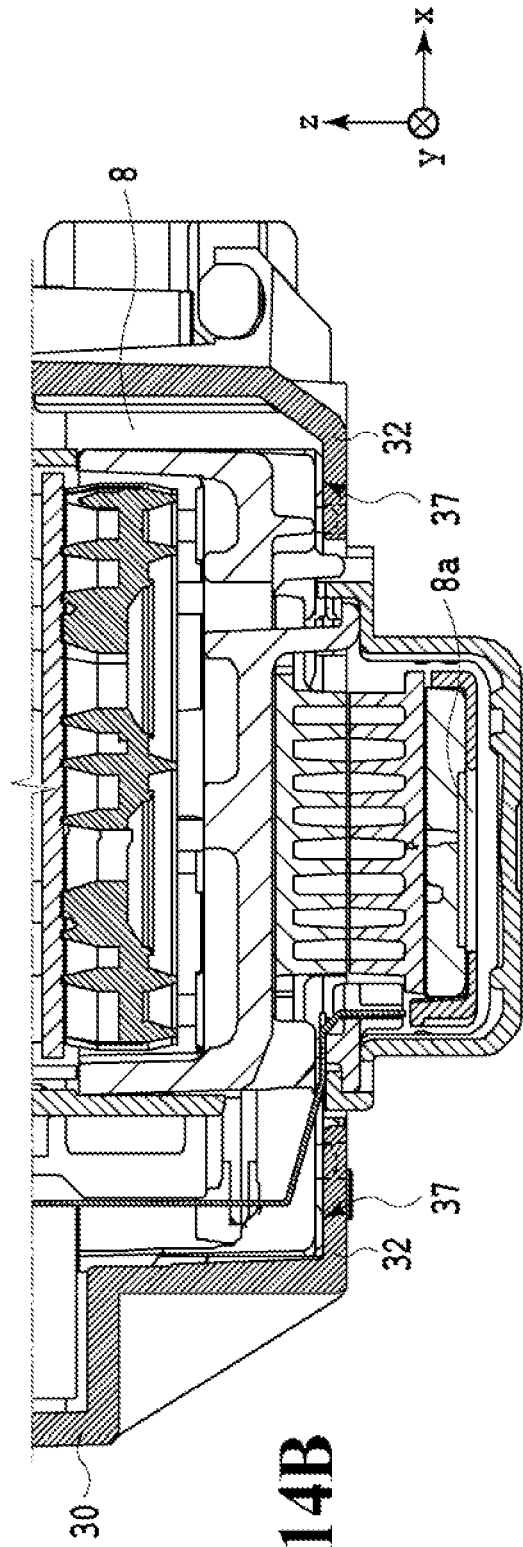

FIG. 14B

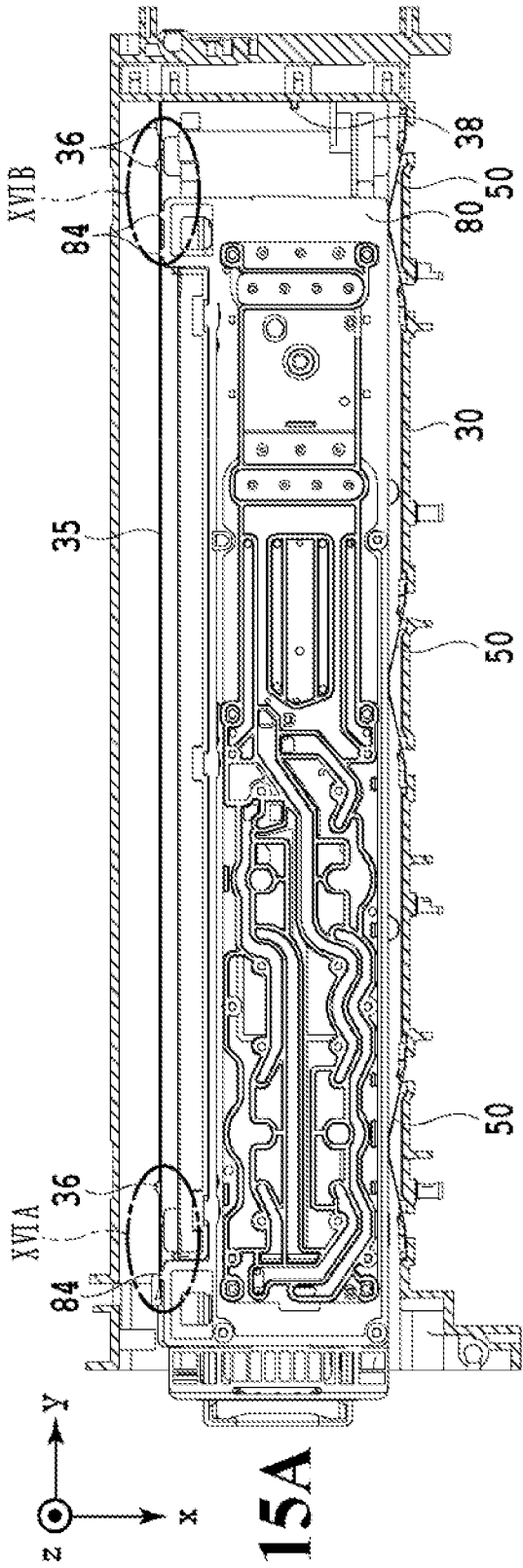

FIG. 15A

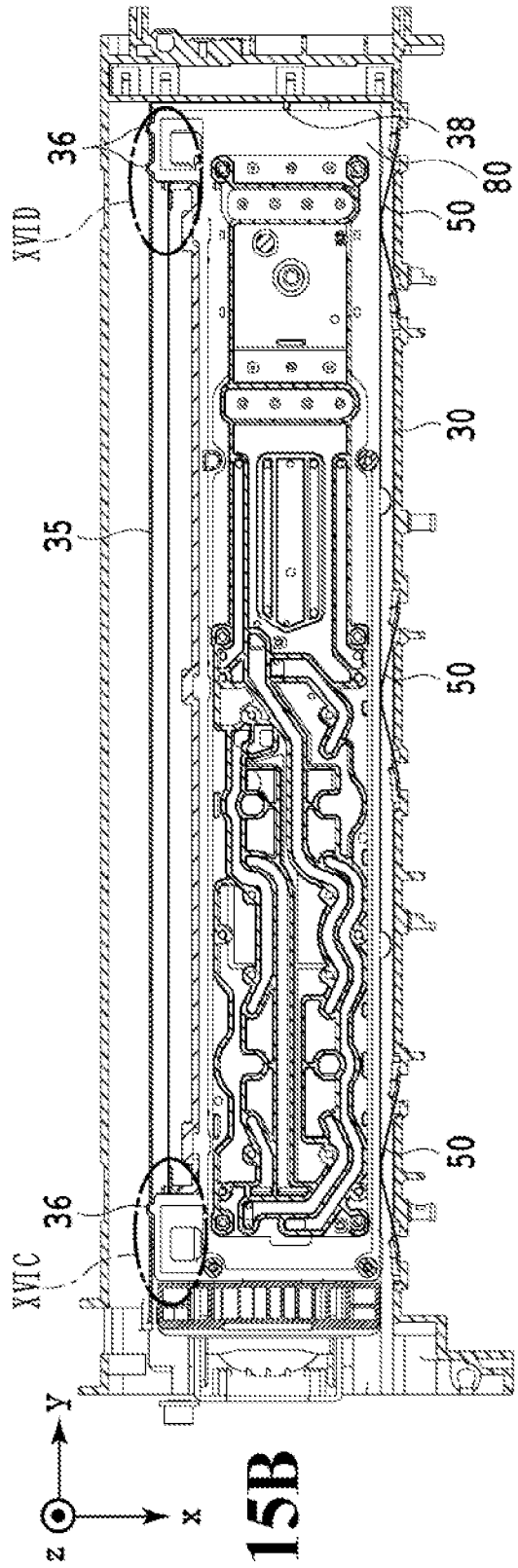

FIG. 15B

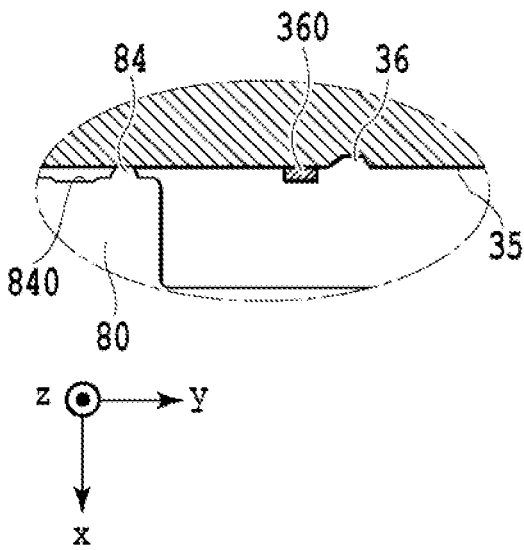

FIG. 16A

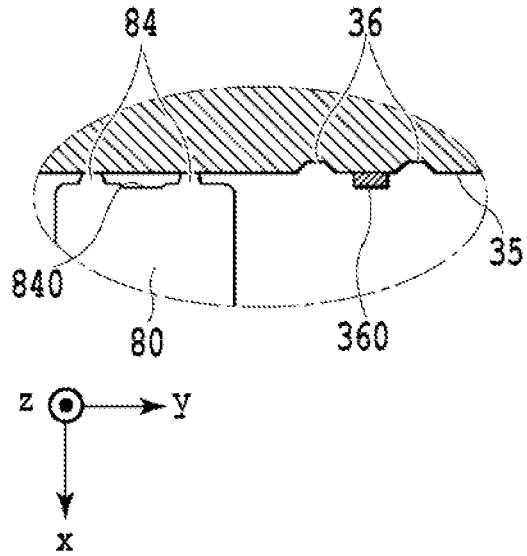

FIG. 16B

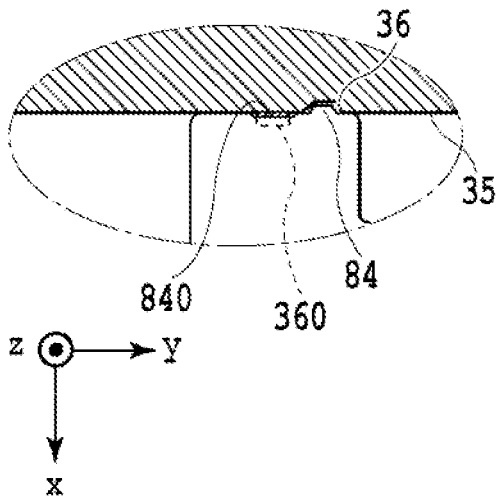

FIG. 16C

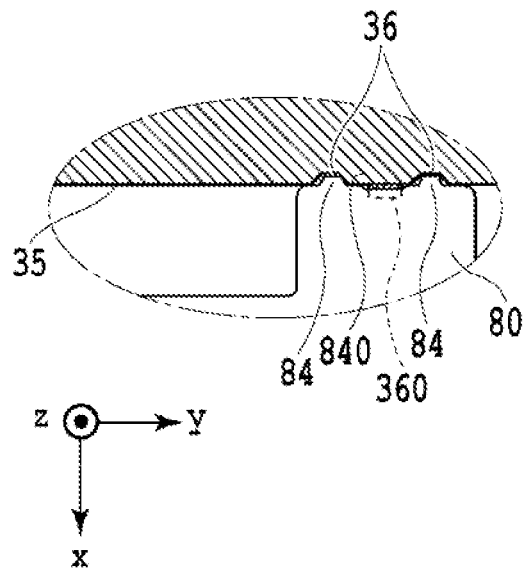

FIG. 16D

INKJET PRINTING APPARATUS

BACKGROUND OF THE INVENTION

Field of the Invention

[0001] The present invention relates to an inkjet printing apparatus comprising a print head that ejects ink to print an image.

Description of the Related Art

[0002] Japanese Patent Laid-Open No. 2001-63080 discloses a cover for protecting an ejection opening surface of an inkjet print head attachable to and detachable from an apparatus body. According to Japanese Patent Laid-Open No. 2001-63080, at the time of replacement of the print head, a user removes the cover from the print head and attaches the print head without the cover to the apparatus.

[0003] However, in the configuration disclosed in Japanese Patent Laid-Open No. 2001-63080, a user manually removes the cover and attaches the print head. This raises the possibility that the ejection opening surface exposed after the removal of the cover is damaged at the time of attachment of the print head. In particular, in the case of a relatively large print head to be attached to a full line printing apparatus, since the ejection opening surface has a large area and the print head is heavy, there is a high possibility that the ejection opening surface contacts another object at the time of replacement of the print head.

SUMMARY OF THE INVENTION

[0004] The present invention has been accomplished in order to solve the above problem. Thus, an object is to provide an inkjet printing apparatus that is capable of suppressing damage to an ejection opening surface at the time of replacement of a print head and attaching the print head to a suitable position with a simplified configuration.

[0005] In an aspect of the present invention, there is provided an inkjet printing apparatus comprising: a print head comprising an ejection opening surface on which ejection openings configured to eject ink are arrayed in a width direction of a printing medium; a protective member configured to protect the ejection opening surface being detachably attached to the print head; a head holder configured to hold the print head detachably; and a guide portion provided in the head holder and configured to guide the print head to which the protective member is attached toward a predetermined position in the width direction, wherein the guide portion guides the print head downstream of the predetermined position and prevents the protective member from exceeding the predetermined position.

[0006] Further features of the present invention will become apparent from the following description of exemplary embodiments with reference to the attached drawings.

BRIEF DESCRIPTION OF THE DRAWINGS

[0007] FIG. 1 is a diagram of a printing apparatus in a standby state;

[0008] FIG. 2 is a control configuration diagram of the printing apparatus;

[0009] FIG. 3 is a diagram of the printing apparatus in a printing state;

[0010] FIGS. 4A to 4C are diagrams of a conveying path of a printing medium conveyed from a first cassette;

[0011] FIGS. 5A to 5C are diagrams of a conveying path of a printing medium conveyed from a second cassette;

[0012] FIGS. 6A to 6D are diagrams of a conveying path in the case of performing print operation for the back side of a printing medium;

[0013] FIG. 7 is a diagram of the printing apparatus in a maintenance state;

[0014] FIG. 8 is an external perspective view of the printing apparatus;

[0015] FIG. 9 is a diagram showing a state where a print head is inserted into a head holder;

[0016] FIGS. 10A and 10B are diagrams showing states of attachment of a protective member to the print head;

[0017] FIGS. 11A and 11B are diagrams showing states of attachment of the print head to the head holder;

[0018] FIGS. 12A to 12C are diagrams showing a mechanism of removal of the protective member from the print head;

[0019] FIG. 13 is a diagram showing the head holder from above;

[0020] FIGS. 14A and 14B are enlarged cross-sectional views of the print head and the head holder;

[0021] FIGS. 15A and 15B are top views of the head holder with the print head inserted; and

[0022] FIGS. 16A to 16D are enlarged views showing positioning states on a side surface.

DESCRIPTION OF THE EMBODIMENTS

[0023] FIG. 1 is an internal configuration diagram of an inkjet printing apparatus 1 (hereinafter “printing apparatus 1”) used in the present embodiment. In the drawings, an x direction is a horizontal direction, a y direction (a direction perpendicular to paper) is a direction in which ejection openings are arrayed in a print head 8 described later, and a z direction is a vertical direction.

[0024] The printing apparatus 1 is a multifunction printer comprising a print unit 2 and a scanner unit 3. The printing apparatus 1 can use the print unit 2 and the scanner unit 3 separately or in synchronization to perform various processes related to print operation and scan operation. The scanner unit 3 comprises an automatic document feeder (ADF) and a flatbed scanner (FBS) and is capable of scanning a document automatically fed by the ADF as well as scanning a document placed by a user on a document plate of the FBS. The present embodiment is directed to the multifunction printer comprising both the print unit 2 and the scanner unit 3, but the scanner unit 3 may be omitted. FIG. 1 shows the printing apparatus 1 in a standby state in which neither print operation nor scan operation is performed.

[0025] In the print unit 2, a first cassette 5A and a second cassette 5B for housing printing medium (cut sheets) S are detachably provided at the bottom of a casing 4 in the vertical direction. Relatively small printing medium of up to A4 size are stacked and housed in the first cassette 5A and relatively large printing medium of up to A3 size are stacked and housed in the second cassette 5B. A first feeding unit 6A for feeding housed printing medium one by one is provided near the first cassette 5A. Similarly, a second feeding unit 6B is provided near the second cassette 5B. In print operation, a printing medium S is selectively fed from either one of the cassettes.

[0026] Conveying rollers 7, a discharging roller 12, pinch rollers 7a, spurs 7b, a guide 18, an inner guide 19, and a

flapper **11** are conveying mechanisms for guiding a printing medium **S** in a predetermined direction. The conveying rollers **7** are drive rollers located upstream and downstream of the print head **8** and driven by a conveying motor (not shown). The pinch rollers **7a** are follower rollers that are turned while nipping a printing medium **S** together with the conveying rollers **7**. The discharging roller **12** is a drive roller located downstream of the conveying rollers **7** and driven by the conveying motor (not shown). The spurs **7b** nip and convey a printing medium **S** together with the conveying rollers **7** and discharging roller **12** located downstream of the print head **8**.

[0027] The guide **18** is provided in a conveying path of a printing medium **S** to guide the printing medium **S** in a predetermined direction. The inner guide **19** is a member extending in the *y* direction. The inner guide **19** has a curved side surface and guides a printing medium **S** along the side surface. The flapper **11** is a member for changing a direction in which a printing medium **S** is conveyed in duplex print operation. A discharging tray **13** is a tray for stacking and housing printing medium **S** that were subjected to print operation and discharged by the discharging roller **12**.

[0028] The print head **8** of the present embodiment is a full line type color inkjet print head. In the print head **8**, a plurality of ejection openings configured to eject ink based on print data are arrayed in the *y* direction in FIG. **1** so as to correspond to the width of a printing medium **S**. When the print head **8** is in a standby position, an ejection opening surface **8a** of the print head **8** is oriented vertically downward and capped with a cap unit **10** as shown in FIG. **1**. In print operation, the orientation of the print head **8** is changed by a print controller **202** described later such that the ejection opening surface **8a** faces a platen **9**. The platen **9** includes a flat plate extending in the *y* direction and supports a printing medium **S** being subjected to print operation by the print head **8** from the back side. The movement of the print head **8** from the standby position to a printing position will be described later in detail.

[0029] An ink tank unit **14** separately stores ink of four colors to be supplied to the print head **8**. An ink supply unit **15** is provided in the midstream of a flow path connecting the ink tank unit **14** to the print head **8** to adjust the pressure and flow rate of ink in the print head **8** within a suitable range. The present embodiment adopts a circulation type ink supply system, where the ink supply unit **15** adjusts the pressure of ink supplied to the print head **8** and the flow rate of ink collected from the print head **8** within a suitable range.

[0030] A maintenance unit **16** comprises the cap unit **10** and a wiping unit **17** and activates them at predetermined timings to perform maintenance operation for the print head **8**. The maintenance operation will be described later in detail.

[0031] FIG. **2** is a block diagram showing a control configuration in the printing apparatus **1**. The control configuration mainly includes a print engine unit **200** that exercises control over the print unit **2**, a scanner engine unit **300** that exercises control over the scanner unit **3**, and a controller unit **100** that exercises control over the entire printing apparatus **1**. A print controller **202** controls various mechanisms of the print engine unit **200** under instructions from a main controller **101** of the controller unit **100**. Various mechanisms of the scanner engine unit **300** are

controlled by the main controller **101** of the controller unit **100**. The control configuration will be described below in detail.

[0032] In the controller unit **100**, the main controller **101** including a CPU controls the entire printing apparatus **1** using a RAM **106** as a work area in accordance with various parameters and programs stored in a ROM **107**. For example, when a print job is input from a host apparatus **400** via a host I/F **102** or a wireless I/F **103**, an image processing unit **108** executes predetermined image processing for received image data under instructions from the main controller **101**. The main controller **101** transmits the image data subjected to the image processing to the print engine unit **200** via a print engine I/F **105**.

[0033] The printing apparatus **1** may acquire image data from the host apparatus **400** via a wireless or wired communication or acquire image data from an external storage unit (such as a USB memory) connected to the printing apparatus **1**. A communication system used for the wireless or wired communication is not limited. For example, as a communication system for the wireless communication, Wi-Fi (Wireless Fidelity; registered trademark) and Bluetooth (registered trademark) can be used. As a communication system for the wired communication, a USB (Universal Serial Bus) and the like can be used. For example, when a scan command is input from the host apparatus **400**, the main controller **101** transmits the command to the scanner unit **3** via a scanner engine I/F **109**.

[0034] An operating panel **104** is a mechanism to allow a user to do input and output for the printing apparatus **1**. A user can give an instruction to perform operation such as copying and scanning, set a print mode, and recognize information about the printing apparatus **1** via the operating panel **104**.

[0035] In the print engine unit **200**, the print controller **202** including a CPU controls various mechanisms of the print unit **2** using a RAM **204** as a work area in accordance with various parameters and programs stored in a ROM **203**. When various commands and image data are received via a controller I/F **201**, the print controller **202** temporarily stores them in the RAM **204**. The print controller **202** allows an image processing controller **205** to convert the stored image data into print data such that the print head **8** can use it for print operation. After the generation of the print data, the print controller **202** allows the print head **8** to perform print operation based on the print data via a head I/F **206**. At this time, the print controller **202** conveys a printing medium **S** by driving the feeding units **6A** and **6B**, conveying rollers **7**, discharging roller **12**, and flapper **11** shown in FIG. **1** via a conveyance control unit **207**. The print head **8** performs print operation in synchronization with the conveyance operation of the printing medium **S** under instructions from the print controller **202**, thereby performing printing.

[0036] A head carriage control unit **208** changes the orientation and position of the print head **8** in accordance with an operating state of the printing apparatus **1** such as a maintenance state or a printing state. An ink supply control unit **209** controls the ink supply unit **15** such that the pressure of ink supplied to the print head **8** is within a suitable range. A maintenance control unit **210** controls the operation of the cap unit **10** and wiping unit **17** in the maintenance unit **16** when performing maintenance operation for the print head **8**.

[0037] In the scanner engine unit 300, the main controller 101 controls hardware resources of the scanner controller 302 using the RAM 106 as a work area in accordance with various parameters and programs stored in the ROM 107, thereby controlling various mechanisms of the scanner unit 3. For example, the main controller 101 controls hardware resources in the scanner controller 302 via a controller I/F 301 to cause a conveyance control unit 304 to convey a document placed by a user on the ADF and cause a sensor 305 to scan the document. The scanner controller 302 stores scanned image data in a RAM 303. The print controller 202 can convert the image data acquired as described above into print data to enable the print head 8 to perform print operation based on the image data scanned by the scanner controller 302.

[0038] FIG. 3 shows the printing apparatus 1 in a printing state. As compared with the standby state shown in FIG. 1, the cap unit 10 is separated from the ejection opening surface 8a of the print head 8 and the ejection opening surface 8a faces the platen 9. In the present embodiment, the plane of the platen 9 is inclined about 45° with respect to the horizontal plane. The ejection opening surface 8a of the print head 8 in a printing position is also inclined about 45° with respect to the horizontal plane so as to keep a constant distance from the platen 9.

[0039] In the case of moving the print head 8 from the standby position shown in FIG. 1 to the printing position shown in FIG. 3, the print controller 202 uses the maintenance control unit 210 to move the cap unit 10 down to an evacuation position shown in FIG. 3, thereby separating the cap member 10a from the ejection opening surface 8a of the print head 8. The print controller 202 then uses the head carriage control unit 208 to turn the print head 8 45° while adjusting the vertical height of the print head 8 such that the ejection opening surface 8a faces the platen 9. After the completion of print operation, the print controller 202 reverses the above procedure to move the print head 8 from the printing position to the standby position.

[0040] Next, a conveying path of a printing medium S in the print unit 2 will be described. When a print command is input, the print controller 202 first uses the maintenance control unit 210 and the head carriage control unit 208 to move the print head 8 to the printing position shown in FIG. 3. The print controller 202 then uses the conveyance control unit 207 to drive either the first feeding unit 6A or the second feeding unit 6B in accordance with the print command and feed a printing medium S.

[0041] FIGS. 4A to 4C are diagrams showing a conveying path in the case of feeding an A4 size printing medium S from the first cassette 5A. A printing medium S at the top of a stack of printing medium in the first cassette 5A is separated from the rest of the stack by the first feeding unit 6A and conveyed toward a print area P between the platen 9 and the print head 8 while being nipped between the conveying rollers 7 and the pinch rollers 7a. FIG. 4A shows a conveying state where the front end of the printing medium S is about to reach the print area P. The direction of movement of the printing medium S is changed from the horizontal direction (x direction) to a direction inclined about 45° with respect to the horizontal direction while being fed by the first feeding unit 6A to reach the print area P.

[0042] In the print area P, a plurality of ejection openings provided in the print head 8 eject ink toward the printing

medium S. In an area where ink is applied to the printing medium S, the back side of the printing medium S is supported by the platen 9 so as to keep a constant distance between the ejection opening surface 8a and the printing medium S. After ink is applied to the printing medium S, the conveying rollers 7 and the spurs 7b guide the printing medium S such that the printing medium S passes on the left of the flapper 11 with its tip inclined to the right and is conveyed along the guide 18 in the vertically upward direction of the printing apparatus 1. FIG. 4B shows a state where the front end of the printing medium S has passed through the print area P and the printing medium S is being conveyed vertically upward. The conveying rollers 7 and the spurs 7b change the direction of movement of the printing medium S from the direction inclined about 45° with respect to the horizontal direction in the print area P to the vertically upward direction.

[0043] After being conveyed vertically upward, the printing medium S is discharged into the discharging tray 13 by the discharging roller 12 and the spurs 7b. FIG. 4C shows a state where the front end of the printing medium S has passed through the discharging roller 12 and the printing medium S is being discharged into the discharging tray 13. The discharged printing medium S is held in the discharging tray 13 with the side on which an image was printed by the print head 8 down.

[0044] FIGS. 5A to 5C are diagrams showing a conveying path in the case of feeding an A3 size printing medium S from the second cassette 5B. A printing medium S at the top of a stack of printing medium in the second cassette 5B is separated from the rest of the stack by the second feeding unit 6B and conveyed toward the print area P between the platen 9 and the print head 8 while being nipped between the conveying rollers 7 and the pinch rollers 7a.

[0045] FIG. 5A shows a conveying state where the front end of the printing medium S is about to reach the print area P. In a part of the conveying path, through which the printing medium S is fed by the second feeding unit 6B toward the print area P, the plurality of conveying rollers 7, the plurality of pinch rollers 7a, and the inner guide 19 are provided such that the printing medium S is conveyed to the platen 9 while being bent into an S-shape.

[0046] The rest of the conveying path is the same as that in the case of the A4 size printing medium S shown in FIGS. 4B and 4C. FIG. 5B shows a state where the front end of the printing medium S has passed through the print area P and the printing medium S is being conveyed vertically upward. FIG. 5C shows a state where the front end of the printing medium S has passed through the discharging roller 12 and the printing medium S is being discharged into the discharging tray 13.

[0047] FIGS. 6A to 6D show a conveying path in the case of performing print operation (duplex printing) for the back side (second side) of an A4 size printing medium S. In the case of duplex printing, print operation is first performed for the first side (front side) and then performed for the second side (back side). A conveying procedure during print operation for the first side is the same as that shown in FIGS. 4A to 4C and therefore description will be omitted. A conveying procedure subsequent to FIG. 4C will be described below.

[0048] After the print head 8 finishes print operation for the first side and the back end of the printing medium S passes by the flapper 11, the print controller 202 turns the conveying rollers 7 backward to convey the printing

medium S into the printing apparatus 1. At this time, since the flapper 11 is controlled by an actuator (not shown) such that the tip of the flapper 11 is inclined to the left, the front end of the printing medium S (corresponding to the back end during the print operation for the first side) passes on the right of the flapper 11 and is conveyed vertically downward. FIG. 6A shows a state where the front end of the printing medium S (corresponding to the back end during the print operation for the first side) is passing on the right of the flapper 11.

[0049] Then, the printing medium S is conveyed along the curved outer surface of the inner guide 19 and then conveyed again to the print area P between the print head 8 and the platen 9. At this time, the second side of the printing medium S faces the ejection opening surface 8a of the print head 8. FIG. 6B shows a conveying state where the front end of the printing medium S is about to reach the print area P for print operation for the second side.

[0050] The rest of the conveying path is the same as that in the case of the print operation for the first side shown in FIGS. 4B and 4C. FIG. 6C shows a state where the front end of the printing medium S has passed through the print area P and the printing medium S is being conveyed vertically upward. At this time, the flapper 11 is controlled by the actuator (not shown) such that the tip of the flapper 11 is inclined to the right. FIG. 6D shows a state where the front end of the printing medium S has passed through the discharging roller 12 and the printing medium S is being discharged into the discharging tray 13.

[0051] Next, maintenance operation for the print head 8 will be described. As described with reference to FIG. 1, the maintenance unit 16 of the present embodiment comprises the cap unit 10 and the wiping unit 17 and activates them at predetermined timings to perform maintenance operation.

[0052] FIG. 7 is a diagram showing the printing apparatus 1 in a maintenance state. In the case of moving the print head 8 from the standby position shown in FIG. 1 to a maintenance position shown in FIG. 7, the print controller 202 moves the print head 8 vertically upward and moves the cap unit 10 vertically downward. The print controller 202 then moves the wiping unit 17 from the evacuation position to the right in FIG. 7. After that, the print controller 202 moves the print head 8 vertically downward to the maintenance position where maintenance operation can be performed.

[0053] On the other hand, in the case of moving the print head 8 from the printing position shown in FIG. 3 to the maintenance position shown in FIG. 7, the print controller 202 moves the print head 8 vertically upward while turning it 45°. The print controller 202 then moves the wiping unit 17 from the evacuation position to the right. Following that, the print controller 202 moves the print head 8 vertically downward to the maintenance position where maintenance operation can be performed by the maintenance unit 16.

[0054] FIG. 8 is an external perspective view of the printing apparatus 1, showing a state where a front door 20 and a head holder door 31 openable and closable by a user are both open. The print head 8 of the present embodiment is replaceable in the printing apparatus 1. In the case of replacing the print head 8, a user first opens the front door 20 at the front of the apparatus as illustrated and then opens the head holder door 31 located inside. After that, a user inserts the print head 8 into a head holder 30 provided inside the head holder door 31 from front to back in a +y direction in the drawing.

[0055] FIG. 9 is a diagram showing a state where the print head 8 is inserted into the head holder 30. The head holder 30 has a shape capable of accommodating the entire print head 8. A position in the head holder 30 corresponding to the ejection opening surface 8a of the print head 8 is provided with an opening for exposing the ejection opening surface 8a. A user inserts the print head 8 placed on a sliding bottom surface 32 of the head holder 30, checks that the print head 8 abuts on the end, and then closes the head holder door 31.

[0056] In the description below, an x direction is a lateral direction of the print head 8 (direction of the side surface), a y direction is a longitudinal direction of the print head 8 (width direction of a printing medium), and a z direction is an ejection direction of the print head 8. As described above, the print head 8 of the present embodiment is turnable inside the printing apparatus 1 and x, y, and z axes of the print head do not always correspond to the x, y, and z axes of the printing apparatus 1, but basically correspond to the x, y, and z axes in the standby state shown in FIG. 1.

[0057] FIGS. 10A and 10B diagrams showing states of attachment of a protective member (cover) 40 to the print head 8. FIGS. 10A and 10B show the print head 8 from the ejection opening surface 8a side. As shown in FIG. 10A, the protective member 40 has a shape slidable in the longitudinal direction (y direction) while covering the ejection opening surface 8a. The protective member 40 slides rightward in the drawing along a base plate 80 of the print head 8 extending in the longitudinal direction and is fixed at the end of the base plate 80. The left end of the protective member 40 is provided with a stopper 43 for restricting sliding of the protective member 40.

[0058] FIG. 10B is a diagram showing a state where the protective member 40 is fixed to the print head 8. The end of the protective member 40 in the sliding direction (+y direction) is provided with a claw-shaped locking member 41 having a tapered surface and turnable by a force in the lateral direction (-x direction in the drawing). The base plate 80 of the print head 8 is provided with an engagement portion 81 in a position through which the locking member 41 passes. Under this configuration, as the protective member 40 slides in the +y direction and the tapered surface of the locking member 41 abuts on the engagement portion 81, the locking member 41 is turned clockwise in FIG. 10B by a force in the -x direction. With the locking member 41 turned, the protective member 40 proceeds in the y direction. After the locking member 41 slides in the +y direction to a position beyond the engagement portion 81, the locking member 41 is turned counterclockwise to the original position as shown in FIG. 10B.

[0059] In the state shown in FIG. 10B, the left end of the locking member 41 is in contact with the right end of the engagement portion 81 and the leftward (-y direction) movement of the protective member 40 is restricted. The stopper 43 shown in FIG. 10A is in contact with the left end of the base plate 80 and the rightward (+y direction) movement of the protective member 40 is also restricted. That is, in a state where the locking member 41 and the engagement portion 81 are engaged as shown in FIG. 10B, the protective member 40 is fixed to the print head 8 and the ejection opening surface 8a is protected by the protective member 40. Since the protective member 40 is locked by the locking member 41, a user cannot remove the protective member 40 before attachment of the print head 8 to the printing apparatus 1. In this manner, the print head 8 of the present

embodiment is transported to a user with the ejection opening surface **8a** protected by the protective member **40**.

[0060] FIGS. 11A and 11B are diagrams showing states of attachment of the print head **8** to the head holder **30**. FIG. 11A shows a state where the print head **8** is being inserted into the head holder **30**. FIG. 11B shows a state where the print head **8** has been inserted up to a fixed position. In both of the drawings, the head holder door **31** is omitted.

[0061] The print head **8** of the present embodiment is inserted into the head holder **30** by a user with the protective member **40** attached. During the process of the insertion, the protective member **40** is mechanically removed from the print head **8**.

[0062] FIGS. 12A to 12C are diagrams showing a mechanism of removal of the protective member **40** from the print head **8** along with the insertion of the print head **8**. In FIGS. 12A to 12C, the print head **8** is inserted and moved from left to right into the head holder **30**.

[0063] As shown in FIG. 12A, the locking member **41** and the engagement portion **81** move rightward while maintaining the engagement state shown in FIG. 10B. In the direction of movement (y direction), a first pressing member **33** is provided in a position in the base plate **80** facing the locking member **41**. In the protective member **40**, a protective member end **42** is provided in a position ahead of the locking member **41** in the direction of movement (y direction). A second pressing member **34** is provided in a position in the base plate **80** facing the protective member end **42**.

[0064] FIG. 12B shows a state where the locking member **41** is in contact with the first pressing member **33**. As the tapered surface of the locking member **41** contacts the first pressing member **33**, the locking member **41** is turned clockwise by a force inward in the lateral direction ($-x$ direction) and a space through which the engagement portion **81** can pass is formed outside the locking member **41** ($+x$ side).

[0065] FIG. 12C shows a state where the engagement portion **81** moves rightward through the space formed by turning the locking member **41** and the protective member end **42** is in contact with the second pressing member **34**. The protective member end **42** contacts the second pressing member **34**, thereby restricting the movement of the protective member **40** in the y direction. On the other hand, since the engagement portion **81** and the locking member **41** are disengaged, the protective member **40** is removed from the print head **8**, which enables only the print head **8** to further proceed in the y direction. That is, the protective member **40** will not be inserted ahead of the position shown in FIG. 12C. The print head **8** is positioned with respect to the head holder **30** further downstream in the y direction.

[0066] That is, the locking member **41** contacts the first pressing member **33** and is turned, whereby the protective member **40** is disengaged from the engagement portion **81**, and after that, the protective member end **42** contacts the second pressing member **34** and the movement of the protective member **40** is restricted, whereby the protective member **40** is removed from the print head **8**. Further insertion of the print head **8** forms a gap between the stopper **43** of the protective member **40** and the print head **8**. This enables a user to use the stopper **43** as a gripping portion to pull the protective member **40** frontward (outside the apparatus) (see FIG. 11B).

[0067] As described above, according to the present embodiment, the protective member **40** can be detached

from the print head **8** only after a user inserts, into the head holder **30**, the print head **8** with the protective member **40** attached. That is, a user does not need to touch the protective member **40** to detach the protective member **40** from the print head **8**, which reduces the possibility that the print head **8** is attached after the protective member **40** is accidentally removed. Accordingly, the print head can be attached to a suitable position with a simplified configuration without concern about contamination or damage caused by contact between liquid on the ejection opening surface of the print head **8** and another object.

[0068] Next, the positioning of the print head **8** inside the head holder **30** will be described. FIG. 13 is a diagram showing the head holder **30** without the print head **8**, as viewed from above ($+z$ side).

[0069] Both ends of the opening of the head holder **30** in the lateral direction are provided with a sliding bottom surface **32** extending in they direction. The print head **8** is inserted in the $+y$ direction while sliding on the sliding bottom surfaces **32**. That is, the sliding bottom surface **32** serves as a guide portion for guiding the print head **8** in the $+y$ direction of the head holder **30**. Both ends of the sliding bottom surface **32** in the $\pm x$ direction and both ends of the sliding bottom surface **32** in the $\pm y$ direction are provided with a cut-off portion **39** cut off so as not to contact a sliding portion (not shown in FIG. 13) of the print head **8**. A landing surface **37** is provided further outside the cut-off portion **39** in the $\pm x$ direction so as to guide and position the print head **8** in the z direction (direction of gravity) in the head holder **30**.

[0070] One of the inner walls of the head holder **30** extending in the y direction is provided with three urging members **50** formed from leaf springs, and the other is provided with a sliding side surface **35** formed from a flat plate. Accordingly, the print head **8** inserted into the head holder **30** proceeds in the y direction while being urged by the urging member **50** in the $-x$ direction (direction of the side surface) in the drawing and guided by the sliding side surface **35**. Both ends of the sliding side surface **35** in the $\pm y$ direction are provided with a recess **36** having a shape recessed so as not to contact a protrusion **84** (not shown in FIG. 13) formed on the side surface of the base plate **80**. On the sliding side surface **35**, a positioning rib **360** (see FIGS. 16A to 16D) is formed near the recess **36** for positioning the print head **8** in the x direction. The urging member **50** and the positioning rib **360** described above are features for positioning the print head **8** in the x direction while guiding the print head **8** in the y direction in the head holder **30**.

[0071] Further, one of the inner walls of the head holder **30** extending in the x direction on the back side (surface on the downstream side in the $+y$ direction) is provided with a rib-shaped front positioning member **38** so as to contact the inserted print head **8**. The end of the base plate **80** of the inserted print head **8** abuts on the front positioning member **38** and a user further closes the head holder door **31** described with reference to FIG. 8 and FIG. 9, whereby the position of the print head **8** in they direction is fixed in the head holder **30**. At this time, a spring provided in the head holder door **31** urges the print head **8** in the $+y$ direction. That is, the front positioning member **38** and the spring provided in the head holder door **31** are features for positioning the print head **8** in the y direction in the head holder **30**.

[0072] FIGS. 14A and 14B are enlarged cross-sectional views of the print head 8 and the head holder 30. FIG. 14A shows a state where the print head 8 is being inserted. FIG. 14B shows a state where the print head 8 has been inserted and positioned. On the bottom of the base plate 80 of the print head 8, both ends of the ejection opening surface 8a in the $\pm x$ direction are provided with a sliding portion 82 protruding relatively largely and a landing portion 83 protruding relatively slightly and having a flat plane, which are adjacent to each other.

[0073] In the case of inserting the print head 8, as shown in FIG. 14A, the sliding portion 82 is in contact with and the landing portion 83 is not in contact with the sliding bottom surface 32 of the head holder 30. As the insertion advances, the sliding portion 82 falls into the cut-off portion 39 described with reference to FIG. 13 and the landing portion 83 lands on the landing surface 37 of the sliding bottom surface 32 as shown in FIG. 14B. The contact between the landing portion 83 and the landing surface 37 completes the positioning in the z direction in the head holder. That is, the print head 8 lands on a position lower than the height during insertion by H with respect to the head holder 30.

[0074] In the present embodiment, the sliding bottom surface 32 of the head holder 30 is formed of aluminum. Accordingly, if the sliding of the sliding portion 82 is repeated each time the print head 8 is replaced, the sliding bottom surface 32 may wear out and the positioning accuracy in the z direction may decrease. The print head 8 can be smoothly inserted into the head holder 30 and accurately positioned by individually providing the sliding portion 82 for sliding and the landing portion 83 for positioning like the present embodiment.

[0075] FIGS. 15A and 15B are top views of the head holder 30 with the print head 8 inserted. FIG. 15A shows a state where the print head 8 is being inserted. FIG. 15B shows a state where the print head 8 has been inserted and positioned. A protrusion 84 is provided in both ends in the longitudinal direction of the surface of the base plate 80 of the print head 8 facing the sliding side surface 35. A recess 36 for avoiding the protrusion 84 is provided in both ends of the sliding side surface 35 in the longitudinal direction.

[0076] Under the configuration described above, if the print head 8 is inserted into the head holder 30, the print head 8 is urged in the $-x$ direction in the drawing by the urging member 50, the protrusions 84 contact the sliding side surface 35, and the print head 8 moves in the $+y$ direction while being guided by the sliding side surface 35. FIG. 15A shows a state in the middle of the insertion. In FIG. 15A, the front end of the print head 8 is not in contact with the front positioning member 38.

[0077] FIG. 15B shows a state where the insertion has been completed. In FIG. 15B, the protrusions 84 are accommodated in the recesses 36 and the front end of the print head 8 in the direction of insertion is in contact with the front positioning member 38.

[0078] FIGS. 16A to 16D are enlarged views showing the peripheries of the protrusions 84 and the positioning ribs 360 shown in the left and right in FIGS. 15A and 15B. FIGS. 16A and 16B show the peripheries of the protrusions 84 in a sliding state. The protrusions 84 are urged in the $-x$ direction by the urging member 50 and moved rightward in the drawings while receiving a resisting force from the sliding side surface 35 in contact with the protrusions 84.

[0079] FIGS. 16C and 16D show the protrusions 84 and the recesses 36, which have been positioned by the positioning ribs 360. The recess 360 is configured to avoid the protrusion 84 such that the protrusion 84 urged in the $-x$ direction by the urging member 50 does not contact the recess 360. The print head 8 is positioned in the x direction by contact between a contacting surface 840 of the print head 8 and the positioning rib 360.

[0080] As described above, according to the present embodiment, the print head 8 is guided into the head holder 30 by sliding of the sliding portion 82 and protrusion 84 of the print head 8 along the sliding bottom surface 32 and sliding side surface 35 of the head holder 30, respectively. The print head 8 is positioned in the z direction by contact between the landing portion 83 of the print head 8 and the landing surface 37 of the head holder 30, and is positioned in the x direction by contact between the contacting surface 840 of the print head 8 and the positioning rib 360. After the completion of the insertion, a user closes the head holder door 31, whereby the end of the print head 8 in the depth direction is pushed against the front positioning member 38 by the spring provided in the head holder door 31 and the print head 8 is positioned in the y direction.

[0081] As described above, according to the present invention, the print head can be attached to a suitable position with a simplified configuration while suppressing contamination or damage caused by contact with the ejection opening surface.

[0082] While the present invention has been described with reference to exemplary embodiments, it is to be understood that the invention is not limited to the disclosed exemplary embodiments. The scope of the following claims is to be accorded the broadest interpretation so as to encompass all such modifications and equivalent structures and functions.

[0083] This application claims the benefit of Japanese Patent Application No. 2018-151445, filed Aug. 10, 2018, which is hereby incorporated by reference wherein in its entirety.

What is claimed is:

1. An inkjet printing apparatus comprising:
 - a print head comprising an ejection opening surface on which ejection openings configured to eject ink are arrayed in a width direction of a printing medium;
 - a protective member configured to protect the ejection opening surface being detachably attached to the print head;
 - a head holder configured to hold the print head detachably; and
 - a guide portion provided in the head holder and configured to guide the print head to which the protective member is attached toward a predetermined position in the width direction,
 wherein the guide portion guides the print head downstream of the predetermined position and prevents the protective member from exceeding the predetermined position.
2. The inkjet printing apparatus according to claim 1, wherein the protective member has a locking member engageable with an engagement portion provided in the print head, and
 - the guide portion comprises a first pressing member configured to disengage the locking member and the engagement portion by contacting the locking member

and a second pressing member configured to restrict movement of the protective member downstream of the predetermined position.

3. The inkjet printing apparatus according to claim 2, wherein the locking member contacts the first pressing member, thereby being retracted from a path through which the engagement portion proceeds along with insertion of the print head.

4. The inkjet printing apparatus according to claim 1, wherein an end of the protective member in the width direction is provided with a stopper configured to restrict sliding of the protective member on the print head in a state which the protective member is attached to the print head.

5. The inkjet printing apparatus according to claim 4, wherein the stopper includes a gripping portion configured to allow a user to pull the protective member from the head holder.

6. The inkjet printing apparatus according to claim 1, wherein the guide portion further includes:

a sliding bottom surface configured to guide a first sliding portion provided in the print head in the width direction while supporting the first sliding portion from below in a direction of gravity; and

a landing surface which is provided on the sliding bottom surface and on which a landing portion of the print head lands, and

the print head is positioned in the direction of gravity by landing of the landing portion on the landing surface.

7. The inkjet printing apparatus according to claim 1, wherein the guide portion further includes:

a sliding side surface configured to guide a second sliding portion provided in the print head in the width direction while supporting the second sliding portion in a direction intersecting the width direction and a direction of gravity;

an urging member configured to urge the print head against the sliding side surface; and

a positioning rib which is provided on the sliding side surface, and

the print head is positioned in the intersecting direction by contact between the positioning surface and the positioning rib.

8. The inkjet printing apparatus according to claim 1, wherein the head holder has:

a positioning member configured to contact an end of the print head guided by the guide portion in a direction of movement; and

an opening and closing member configured to open and close an opening for attachment of the print head, and

the print head is positioned in the width direction by closing of the opening and closing member while the end of the print head is in contact with the positioning member.

* * * * *