



US 20180344965A1

(19) **United States**

(12) **Patent Application Publication** (10) **Pub. No.: US 2018/0344965 A1**

**MAYER et al.**

(43) **Pub. Date: Dec. 6, 2018**

(54) **APPARATUS FOR HUMIDIFYING A RESPIRATORY GAS** Oct. 13, 1999 (DE) ..... 199 49 292.1  
Oct. 13, 1999 (DE) ..... 299 18 048.4

(71) Applicant: **ResMed R&D Germany GmbH**,  
Martinsried (DE)

**Publication Classification**

(72) Inventors: **Wolfgang MAYER**, Ebringen (DE);  
**Harald GENGER**, Starnberg (DE);  
**Stefan Rolf MADAUS**, Graefelfing  
(DE); **Andreas KLOPP**, Munich (DE);  
**Stefan Thomas SCHÄTZL**, Schwifting  
(DE); **Harald Wolfgang VÖGELE**,  
Gauting (DE); **Bernd Christoph**  
**LANG**, Graefelfing (DE)

(51) **Int. Cl.**  
*A61M 16/16* (2006.01)  
*A62B 9/00* (2006.01)  
*A61M 16/08* (2006.01)  
*A61M 16/10* (2006.01)  
*A61M 16/00* (2006.01)  
(52) **U.S. Cl.**  
CPC ..... *A61M 16/16* (2013.01); *A62B 9/003*  
(2013.01); *A61M 16/0875* (2013.01); *A61M*  
*16/109* (2014.02); *A61M 16/0057* (2013.01);  
*A61M 16/0066* (2013.01); *A61M 2209/08*  
(2013.01); *A61M 16/105* (2013.01); *A61M*  
*16/0858* (2014.02); *A61M 16/0816* (2013.01);  
*A61M 16/107* (2014.02); *A61M 2016/0027*  
(2013.01); *A61M 2205/42* (2013.01); *A61M*  
*16/162* (2013.01)

(21) Appl. No.: **16/059,261**  
(22) Filed: **Aug. 9, 2018**

**Related U.S. Application Data**

(63) Continuation of application No. 15/846,815, filed on Dec. 19, 2017, now Pat. No. 10,052,450, which is a continuation of application No. 15/373,526, filed on Dec. 9, 2016, now Pat. No. 9,884,163, which is a continuation of application No. 15/042,474, filed on Feb. 12, 2016, now Pat. No. 9,545,494, which is a continuation of application No. 13/916,930, filed on Jun. 13, 2013, now Pat. No. 9,545,493, which is a continuation of application No. 12/958,718, filed on Dec. 2, 2010, now Pat. No. 8,469,025, which is a continuation of application No. 11/414,432, filed on May 1, 2006, now Pat. No. 7,938,112, which is a continuation of application No. 10/048,786, filed on Aug. 6, 2002, now Pat. No. 7,096,864, filed as application No. PCT/EP00/07602 on Aug. 4, 2000.

**Foreign Application Priority Data**

Aug. 5, 1999 (DE) ..... 199 36 499.0  
Oct. 13, 1999 (DE) ..... 199 49 283.2

(57) **ABSTRACT**

A positive pressure gas supply system includes a CPAP unit a humidifier support housing with a receiving portion. The receiving portion is bound by a bottom wall with a heater and at least one side wall extending vertically from the bottom wall. A gas feed opening in the at least one side wall is in fluid communication with a gas feed path from the CPAP unit. A refilling module configured to retain a body of water is removably placed within the receiving portion from a location above the receiving portion so that a metallic part of the refilling module contacts the heater when the refilling module is resting on the bottom wall of the receiving portion. In addition, a sealing device is configured to seal off the refilling module in the receiving portion. The sealing device and the refilling module are removable as a unit from the humidifier support housing.

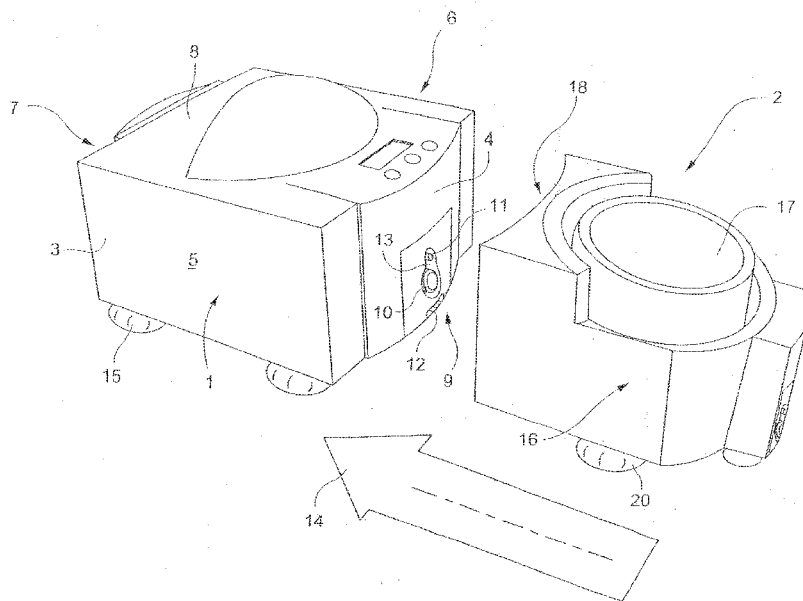

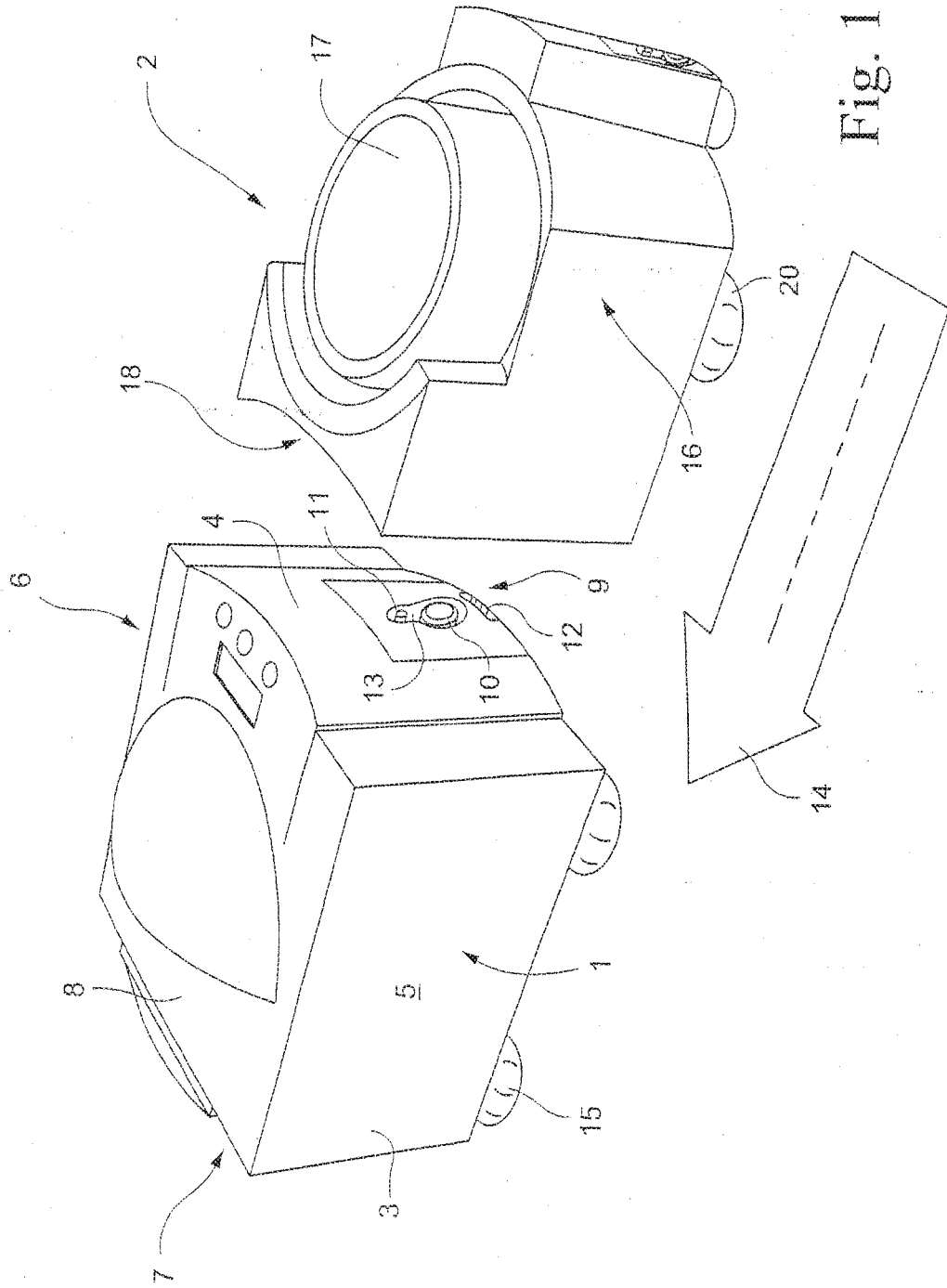

Fig. 1

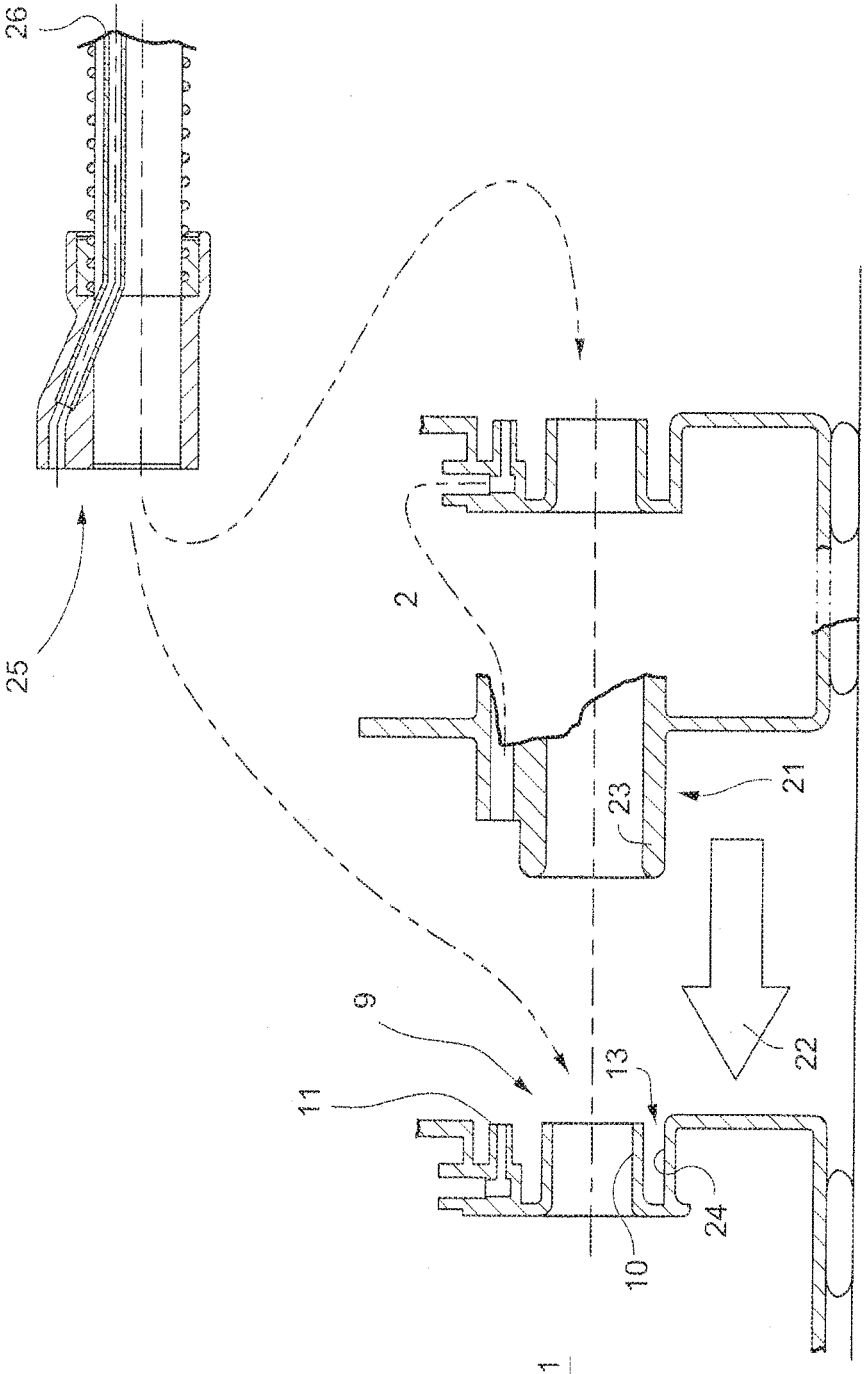

Fig. 2

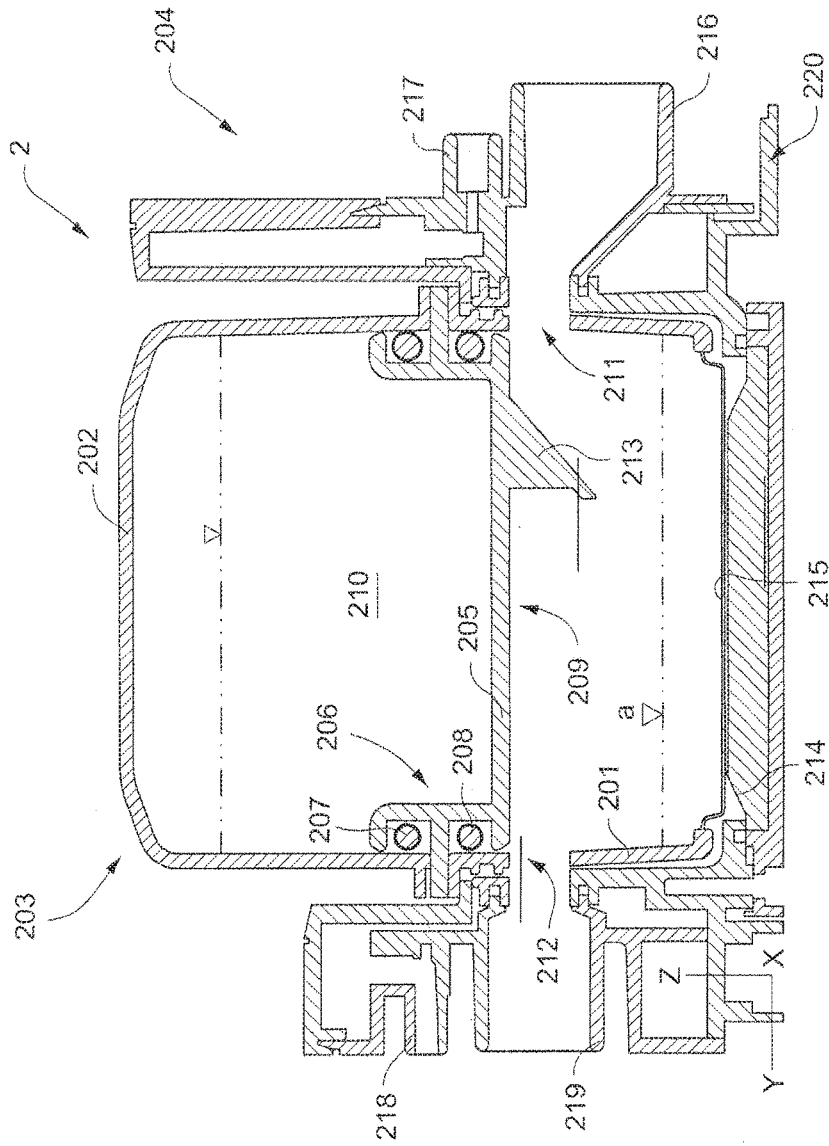

Fig. 3

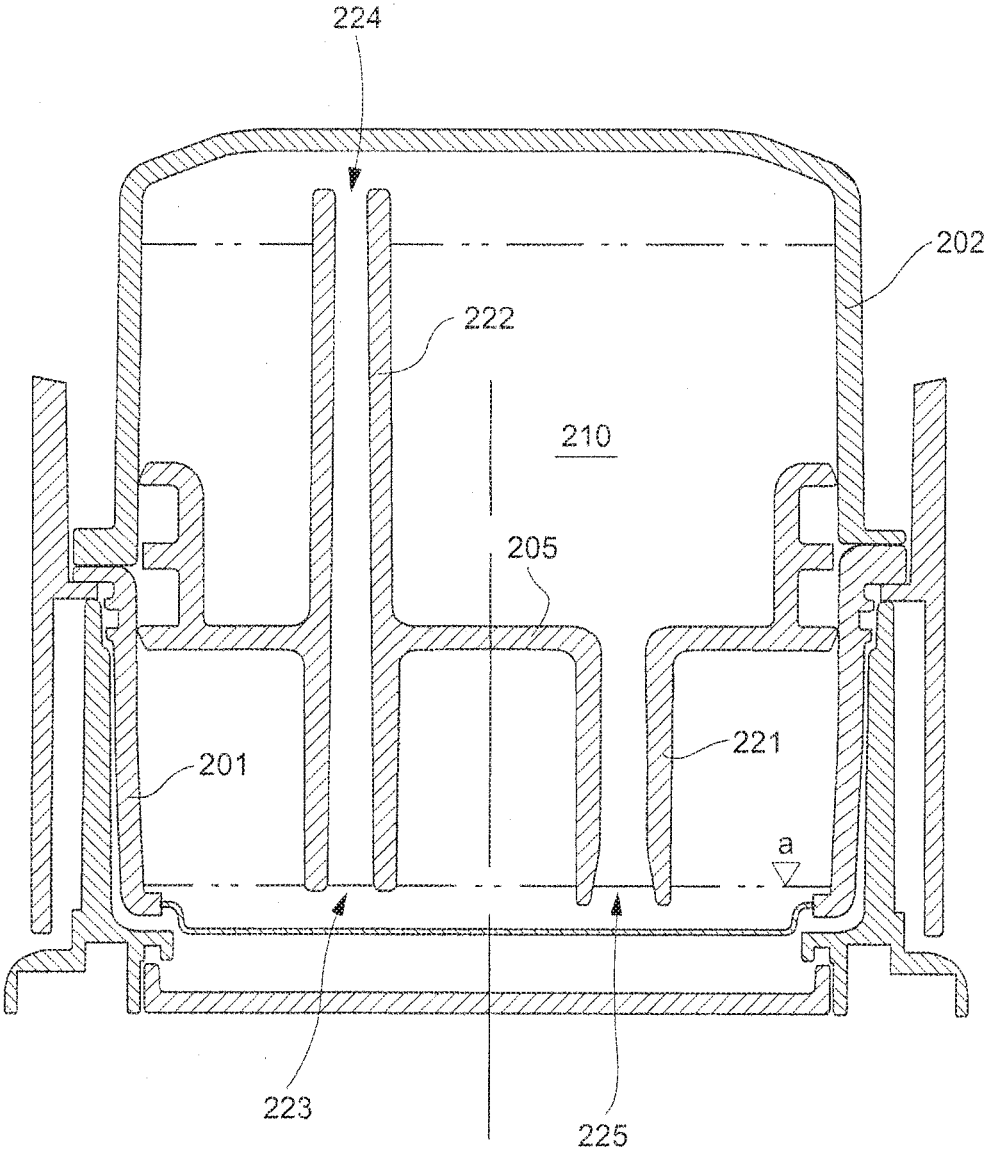

Fig. 4

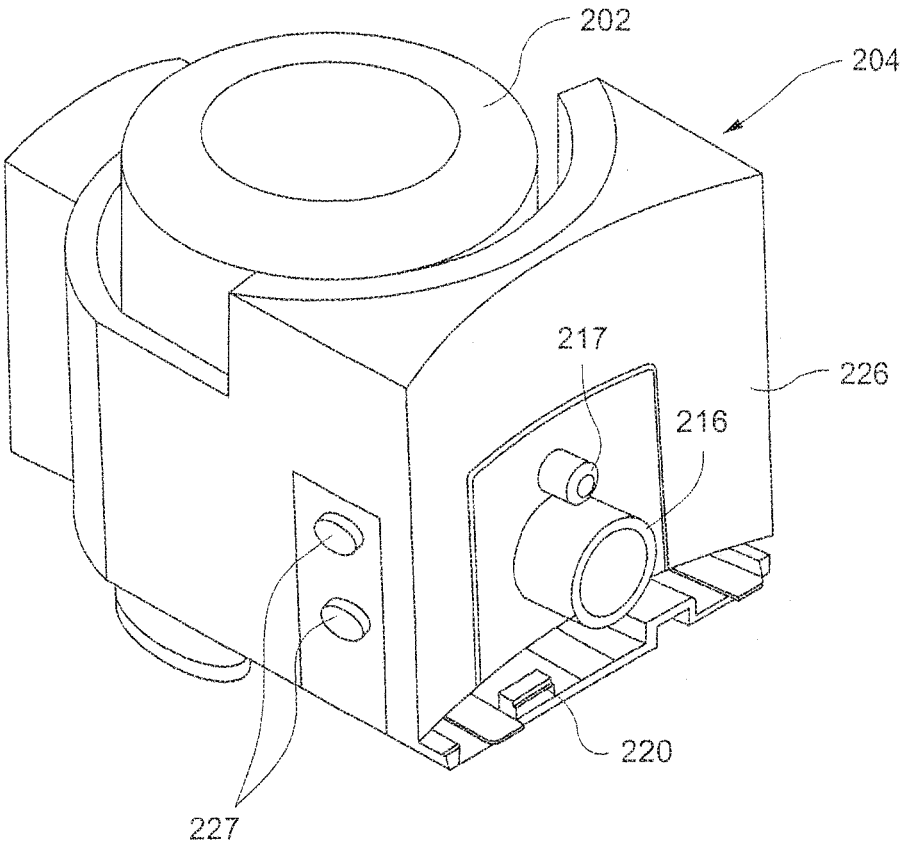

Fig. 5

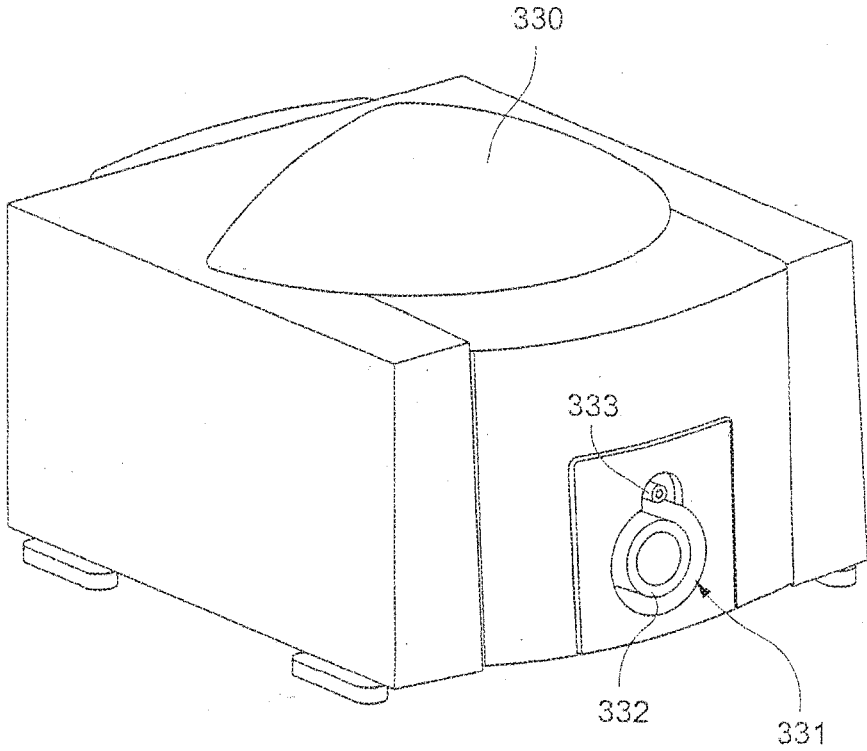

Fig. 6a

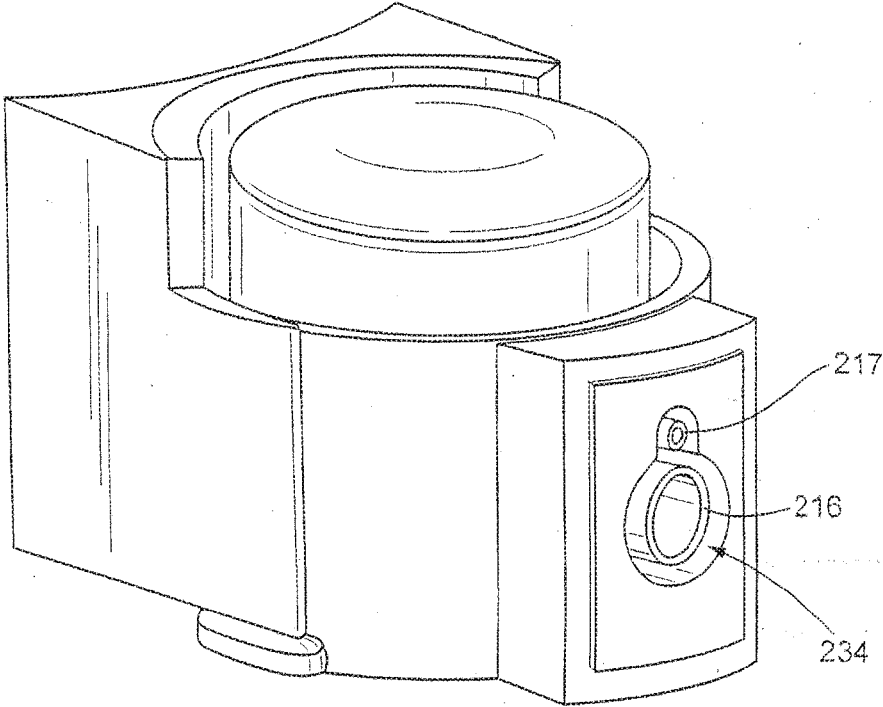

Fig. 6b



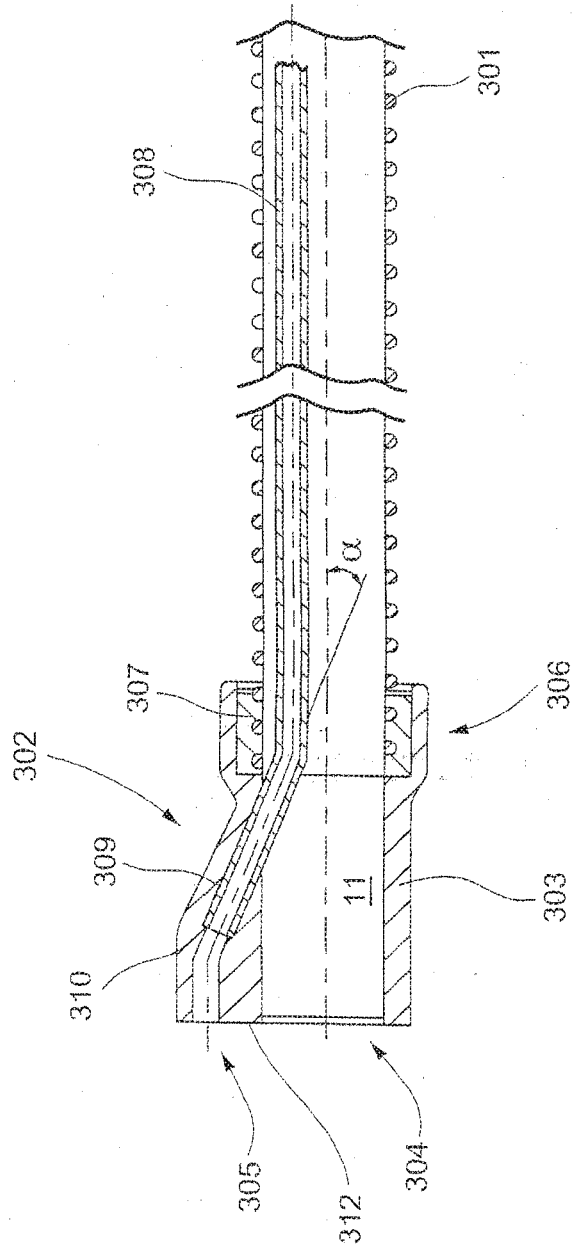

Fig. 7

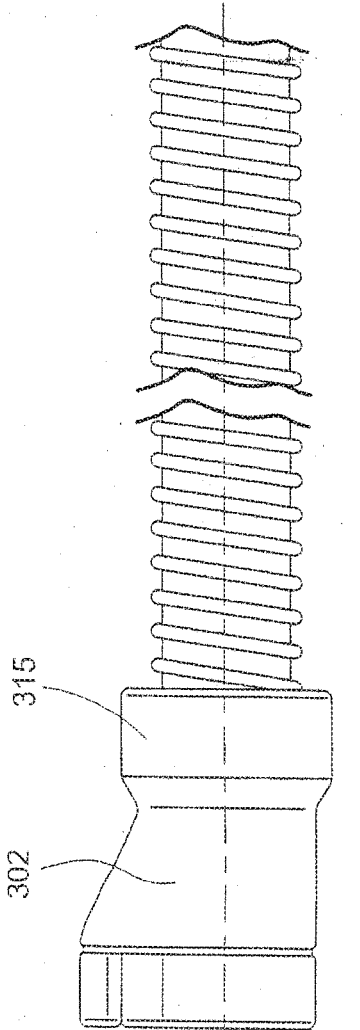

Fig. 8a

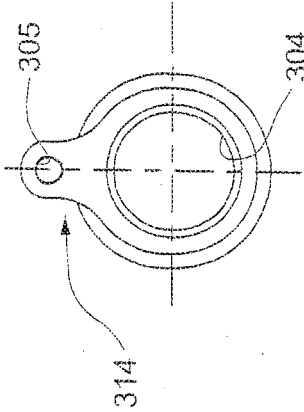

Fig. 8b

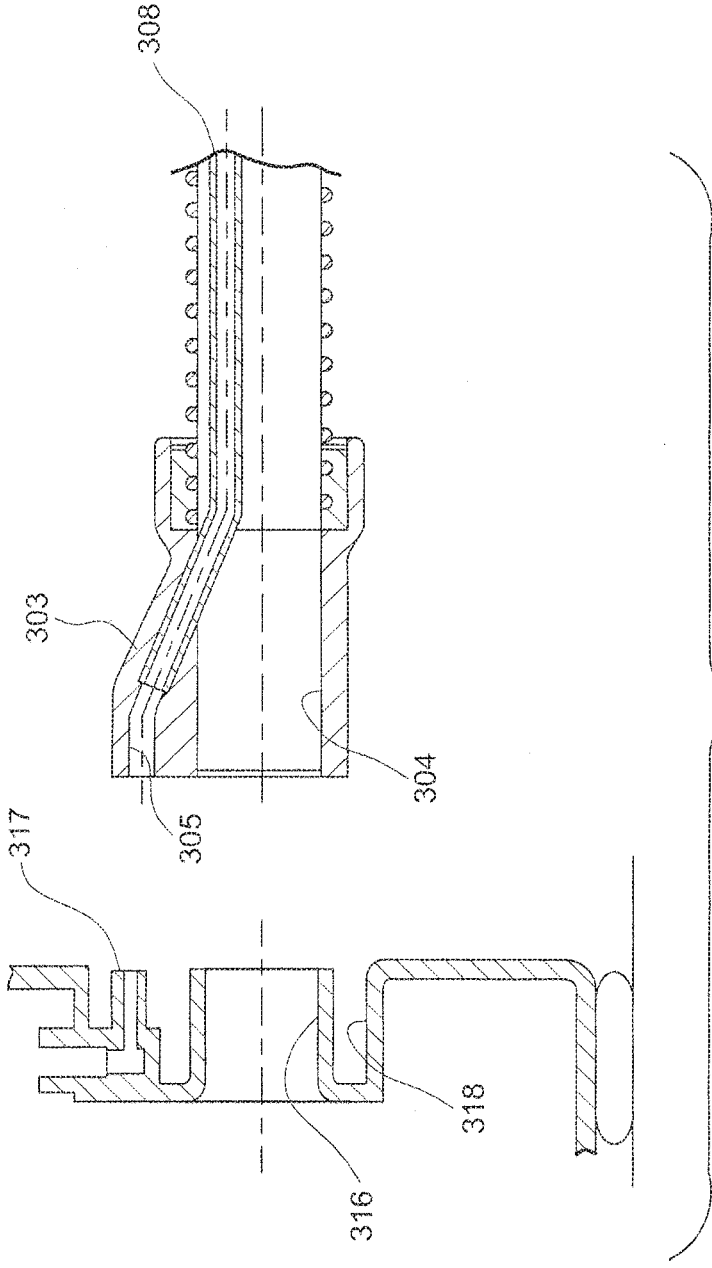

Fig. 9

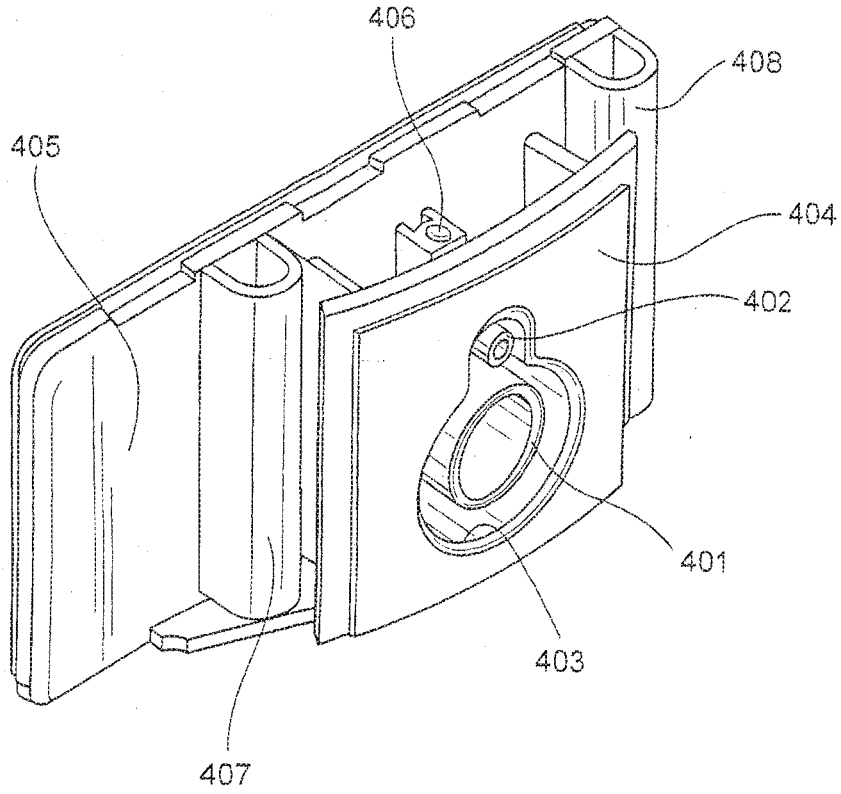

Fig. 10

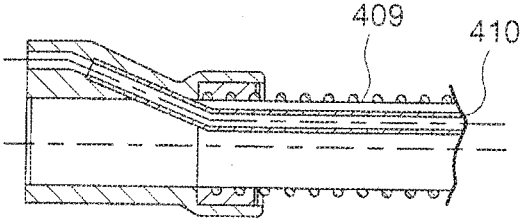

Fig. 11a

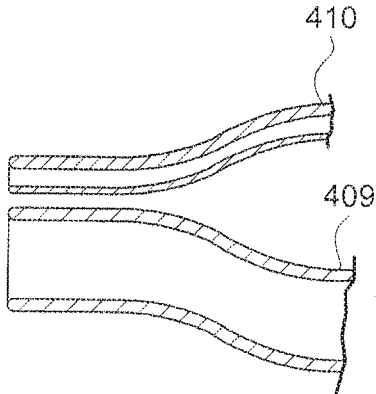

Fig. 11b

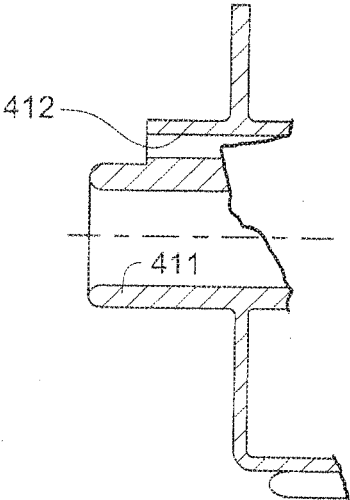

Fig. 11c

## APPARATUS FOR HUMIDIFYING A RESPIRATORY GAS

### CROSS REFERENCE TO RELATED APPLICATIONS

**[0001]** This application is a continuation of U.S. application Ser. No. 15/846,815, filed Dec. 19, 2017, now allowed, which is a continuation of U.S. application Ser. No. 15/373,526, filed Dec. 9, 2016, now U.S. Pat. No. 9,884,163, which is a continuation of U.S. application Ser. No. 15/042,474, filed Feb. 12, 2016, now U.S. Pat. No. 9,545,494, which is a continuation of U.S. application Ser. No. 13/916,930, filed Jun. 13, 2013, now U.S. Pat. No. 9,545,493, which is a continuation of U.S. application Ser. No. 12/958,718, filed Dec. 2, 2010, now U.S. Pat. No. 8,469,025, which is a divisional of U.S. application Ser. No. 11/414,432, filed May 1, 2006, now U.S. Pat. No. 7,938,112, which is a divisional of U.S. application Ser. No. 10/048,786, filed Aug. 6, 2002, now U.S. Pat. No. 7,096,864, which is the National Phase of International Application PCT/EP00/07602, filed Aug. 4, 2000, which designated the U.S. and claims priority to German Application No. 199 36 499.0, filed Aug. 5, 1999, German Application No. 199 49 292.1, filed Oct. 13, 1999, German Application No. 199 49 283.2, filed Oct. 13, 1999 and German Application No. 299 18 048.4, filed Oct. 13, 1999, respectively, each of the above applications being incorporated by reference in its entirety.

### BACKGROUND OF THE INVENTION

#### 1. Field of the Invention

**[0002]** The invention concerns an apparatus for supplying a respiratory gas under an increased pressure comprising a blowing device for delivering the respiratory gas, a housing device for receiving the blowing device and a connecting device for connection of a humidifying apparatus for humidifying the respiratory gas delivered by the delivery device. The invention further concerns a humidifying apparatus for humidifying a respiratory gas as well as a respiratory gas tube or hose and a connecting apparatus therefor.

#### 2. Description of Related Art

**[0003]** Apparatuses for supplying a respiratory gas under an increased pressure are used in particular in the field of sleep therapy for dealing with sleep-related respiratory disturbances. Supplying the respiratory gas under a predetermined increased pressure, usually in the range of between 5 and 20 mbar, provides for pneumatic splinting of the upper respiratory tracts of a patient, in a physiologically well compatible fashion, whereby it is possible to effectively prevent obstruction in that respiratory tract region.

**[0004]** Usually the respiratory gas is formed directly from the ambient air which is preferably sucked in by way of a filter device. In dependence on the climatic conditions which fluctuate in particular due to the time of year involved, it has proven to be advantageous for the respiratory gas which is supplied to the patient, for example by way of a blowing device, under a regulated, possibly alternating pressure, to be humidified from time to time. For that purpose it is possible to insert a humidifying device into the respiratory gas path between the blowing device and the respiratory

mask, for example by way of an intermediate hose portion. CPAP-units with an integrated humidifying apparatus are also known.

**[0005]** In the case of the humidifying apparatuses which are only inserted into a hose line however, there is frequently the problem of inadequate strength and stability. In the case of CPAP-units with an integrated humidifying apparatus the latter has to be constantly taken around, even if there is temporarily no need for humidification of the respiratory gas.

### SUMMARY OF THE INVENTION

**[0006]** Under the impulsion of that problem, the object of the invention is to provide an apparatus for supplying a respiratory gas and a humidifying apparatus which is provided for same, which is robust and simple to handle and which can be configured in an easy fashion according to respective requirements involved.

**[0007]** In accordance with the invention that object is attained by an apparatus for supplying a respiratory gas, having one or more features described below.

**[0008]** By virtue thereof, it is advantageously possible for a humidifying apparatus to be coupled directly laterally to a CPAP-unit easily and without the need for expert assembly procedures, and without the CPAP-unit having to be lifted for that purpose. In that case the lower support portions by way of which the CPAP-unit is set up advantageously act directly as a guide device which permits the humidifying apparatus to be easily pushed to the CPAP-unit. If for example there is temporarily no need for a humidifying apparatus or if the humidifying apparatus is to be temporarily separated from the CPAP-unit for cleaning purposes, the CPAP-unit can remain unchanged at the location at which it is set up and the humidifying apparatus can simply be removed towards the side, in particular by being pulled off.

**[0009]** In accordance with a particularly preferred embodiment of the invention the connecting members are oriented substantially in the joining direction. In particular the main passage cross-section for the respiratory gas which is delivered by the blowing device is advantageously formed by a tube connection, on to which can be fitted a connecting portion which is provided on a humidifying apparatus of correspondingly complementary configuration.

**[0010]** An embodiment of the invention which is particularly advantageous from esthetic points of view and in regard to a symmetrical structure for the CPAP-unit system is afforded if the corresponding connecting members are provided in an end (front side) of the unit. The surface portion of that end of the unit is of a substantially complementary configuration to a portion of the humidifying apparatus, which is adjacent in the joined position.

**[0011]** An embodiment of the invention which is advantageous in particular in regard to particularly reliable coupling of a pressure measuring conduit is afforded if the connecting device has said tube connection for conducting the respiratory gas therethrough and a conduit portion which is arranged adjacent thereto, for coupling a pressure-measuring conduit.

**[0012]** The tube connection for passing the respiratory gas therethrough and the conduit portion for the pressure measuring conduit, in accordance with a particularly preferred embodiment of the invention, are arranged in an opening in such a way that they do not project substantially beyond a

main plane defined by the front end face of the unit. That affords particularly effective protection for these comparatively filigree CPAP-unit connecting members.

**[0013]** In accordance with a particular aspect of the present invention the connecting device, for connection of the humidifying apparatus as required, includes electrical connecting members for affording an electrical connection to the humidifying apparatus. By way of those electrical connecting members it is advantageously possible to supply voltage to a heating device of the humidifying apparatus, without a corresponding voltage supply cable having to be manually connected for that purpose to the humidifying apparatus. The electrical connecting members can also be used for the transmission of electrical signals, for example for the transmission of a filling level signal or also for the transmission of electrical signals which are supplied for example in the region of the respiratory tube connecting device.

**[0014]** A particularly effective coupling for the CPAP-unit to the humidifying apparatus which is intended for connection thereto is achieved in accordance with the invention in that there is provided a latching device which can be manually put into a release position and which holds the humidifying apparatus in a joined position. By virtue of that arrangement it is advantageously possible for the humidifying apparatus to be designed in such a way as to save a great deal of weight, without in that respect involving the risk that it is by mistake pulled off the CPAP-unit by way of the connected respiratory gas tube or hose and caused to fall off the surface on which it is supported (for example an occasional table).

**[0015]** In accordance with a particularly preferred embodiment of the invention the CPAP-unit is designed in the bottom region in such a way that the connecting members and in particular the above-mentioned tube connection are arranged at a vertical heightwise level which exactly corresponds to the heightwise level of the connecting members provided on the humidifying apparatus.

**[0016]** Advantageously, the connecting members provided on the CPAP-unit and also those on the humidifying apparatus are positioned in a vertical direction in such a way that, when the CPAP-unit and the humidifying apparatus are set up on a substantially flat support, the humidifying apparatus can be pushed to the CPAP-unit, in which case the required orientation of those two modules in the vertical direction is already achieved by virtue of the surface on which they are standing. In order also to attain sufficient centering of the two modules in the lateral direction, centering aids are also provided in accordance with a particularly preferred embodiment of the invention. In that respect, a particularly robust centering aid is achieved if the inside wall of the opening which receives the tube connection is matched to the outside peripheral surface of the connecting projection provided on the humidifying apparatus.

**[0017]** In regard to the humidifying apparatus the object set forth hereinbefore is attained by a humidifying apparatus having one or more of the features described below. Such a humidifying apparatus can be coupled in a simple fashion to a suitable CPAP-unit, even by a lay person, without expert assembly procedures or a connecting tube or hose being required for that purpose. The CPAP-unit does not have to be lifted for that purpose.

**[0018]** Advantageously there is provided a humidifier unit which can be coupled to a base unit and which includes a

cartridge-like refilling module which can be removed and re-fitted. The refilling module can be fixed in the humidifier unit by way of fixing devices, for example a bayonet fixing device. The refilling module can be sealed off in a portion-wise manner or completely in the humidifier unit by sealing devices.

**[0019]** In the context of a CPAP-therapy, spontaneous respiration of a patient is assisted by a respiratory gas under permanent increased pressure being supplied to the patient. That increased pressure affords pneumatic splinting of the upper respiratory tracts, whereby it is possible to obviate any respiratory tract obstructions which occur during a patient sleep phase. In the treatment of sleep-related respiratory disturbances in that manner, that increased-pressure artificial respiration usually extends over the entire sleep phase of the patient. In regard to improved physiological compatibility of that increased-pressure artificial respiration it has proven to be advantageous to humidify the respiratory gas which is fed to the patient. Usually, humidification of the respiratory gas is effected by the respiratory gas being passed over a water bath and in so doing absorbing moisture. An amount of water of about 750 ml is usually stored in that water bath. The water bath is preferably slightly heated by means of a heating device. When using those conventional humidifying apparatuses, it has been found that the absolute moisture content of the respiratory gas, as viewed over the entire sleep phase, is subject to in part considerable fluctuations.

**[0020]** To resolve that problem, in accordance with a particular aspect of the present invention, there is described an apparatus, which is simple to handle, for the humidification of a respiratory gas, and a CPAP-unit which is intended for use therewith, by means of which it is possible to achieve uniform humidification of the respiratory gas. That is achieved by an apparatus for the humidification of a respiratory gas comprising a liquid storage space for storage of a liquid, a humidifying region for loading the respiratory gas with the liquid by the respiratory gas coming into contact in the humidifying region with the liquid, a respiratory gas supply device for supplying the respiratory gas to the humidifying region, and a respiratory gas withdrawal device for withdrawal of the humidified respiratory gas from the humidifying region, wherein there is provided a partial-amount discharge device for passing only a partial amount of the liquid stored in the liquid storage space into the humidifying region.

**[0021]** That arrangement makes it advantageously possible to provide a respiratory gas which is humidified according to the respective requirements involved, just a short time after the unit is brought into operation. With a desired heating effect for the humidifying medium, that can be achieved quickly and with a comparatively low level of power draw. As a result of the low level of power draw of the heating device the humidifying apparatus according to the invention is particularly suitable for operation independently of a mains network, by means of a battery or an accumulator.

**[0022]** In accordance with a particularly preferred embodiment of the invention the humidifying region is spatially separated from the liquid storage space. In order for supplying the humidifying medium from the liquid storage space, according to the respective requirements involved, there is preferably provided a fluid conduit device by way of which the humidifying region is in communication with the liquid storage space.

**[0023]** Provided between the humidifying region and the liquid storage space, in accordance with a preferred embodiment of the invention, is a separating wall which separates the humidifying region from the liquid storage space. The fluid conduit device is preferably arranged in such a way that it passes through the separating wall.

**[0024]** An embodiment of the invention which is advantageous in terms of particularly advantageous handleability and reliable filling of the humidifying region is afforded if the liquid storage space is arranged above the humidifying region in the position of use of the apparatus. By virtue of that arrangement, it is possible for the humidifying medium to be passed into the humidifying region as a result of the force of gravity acting thereon. The discharge of a partial amount of the liquid into the humidifying region is advantageously effected in dependence on a level of liquid in the humidifying region. In that way it is possible for a given minimum amount of humidifying liquid to be kept permanently available in the humidifying region.

**[0025]** The filling level in the humidifying region is advantageously quantitatively controlled by the introduction of air into the liquid storage space, for the discharge of a partial amount of the liquid out of the liquid storage space. For that purpose, in accordance with a particularly preferred embodiment, the air for introduction into the liquid storage space is drawn in by way of the humidifying region.

**[0026]** Control of the supply of air is preferably effected by the provision of a metering or quantitative control conduit device which extends between the liquid storage space and the humidifying region, wherein the conduit device has a first mouth opening which is at the height of the level of liquid in the humidifying region and a second mouth opening which opens into the liquid storage space into a region above the level of liquid in the storage space. In that situation the first mouth opening is covered by the liquid disposed in the humidifying region until the level of liquid falls below the first mouth opening. As soon as the first mouth opening is cleared air can then flow into the liquid storage space by way of the quantitative control conduit device. As the result of that make-up flow of air, a small amount of fluid again passes into the humidifying region and the level of the liquid in the humidifying region rises until the first mouth opening is again below the level of the liquid.

**[0027]** The quantitative control conduit device is advantageously formed by a tube conduit which passes through the separating wall in a vertical direction.

**[0028]** The liquid is transferred from the liquid storage space into the humidifying region through a tube projection portion which extends from the separating wall into a region below the first mouth opening of the quantitative control conduit device or the air-introduction conduit device.

**[0029]** An embodiment of the humidifier which is robust and advantageous in terms of manufacture from production-engineering points of view is afforded by the separating wall and the two fluid conduit devices being of an integral nature.

**[0030]** The liquid storage space is preferably formed by a cup-shaped housing portion. That housing portion is preferably formed from a transparent or translucent material. Making the housing portion from a plastic material advantageously provides for protection from splintering and a still further reduction in the level of heat losses.

**[0031]** In accordance with a particularly preferred embodiment of the invention the humidifying region is formed in a trough or vat element. Particularly effective

humidification of the respiration gas, with a structure which is still compact, can advantageously be achieved by the provision of air conduit devices which are arranged in such a way that air flows through the trough element substantially transversely or along a spiral path. That provides intensive contact of the respiratory gas with the partial amount of liquid accommodated in the humidifying region.

**[0032]** Particularly intensive humidification of the respiratory gas can be achieved by the provision of a heating device for heating the partial amount of liquid stored in the humidifying region. The heating device is preferably operated electrically, for example by a resistance heating means. The resistance heating means is preferably formed by a thin foil-like element thermally coupled to a bottom region of the trough element. For that purpose preferably the trough element has a bottom portion which is formed from a material of high thermal conductivity, in particular metal. As an alternative thereto or also in combination therewith, it is also possible for the heating device to be integrated directly into a wall portion, in particular a bottom portion, of the humidifying region.

**[0033]** Advantageously the integral member forming the separating wall is fitted in sealing relationship into the trough element by way of a first peripheral sealing device. The integral member preferably also includes a second peripheral sealing device which closes the liquid storage space in sealing relationship, in conjunction with the separating wall. The humidifying unit which is formed in that way can be opened for the refilling procedure by the trough element being removed from the housing portion which forms the liquid storage space.

**[0034]** In accordance with a particularly preferred embodiment of the invention, to receive the described humidifying unit there is provided a support or installation housing into which at least the trough element can be fitted. Advantageously the trough element or the support housing is provided with a respiration tube connecting device for the connection of a respiration tube. In accordance with a particularly preferred embodiment of the invention there is provided a secondary or duplicate tube connecting device in the region of the respiration tube connecting device. By way of a secondary tube of preferably small diameter, which can be connected to the secondary tube connecting device, it is possible to implement pressure measurement in a region following the humidifying apparatus, for example in the region of a CO<sub>2</sub> exchange valve. The secondary tube connecting device is preferably arranged immediately beside a respiratory tube connecting projection. Advantageously the connecting structure provided on the humidifying apparatus for the respiration tube and preferably also for the secondary tube and in particular the pressure-measuring tube corresponds in respect of its constitution to the connecting structure correspondingly provided on a CPAP-unit. That advantageously provides for compatibility of the tube connections both with the CPAP-unit and also with the humidifying device which is possibly connected therebetween.

**[0035]** In that respect, a robust embodiment which is advantageous from the points of view of production engineering is afforded if the secondary tube connecting device and the respiration tube connecting device are formed integrally with the trough element or with the support housing.

**[0036]** In a particularly preferred embodiment of the invention the humidifying apparatus has connecting mem-



bers which permit direct docking of the humidifying apparatus to a corresponding CPAP-unit.

**[0037]** For that purpose in accordance with a particularly preferred embodiment of the invention the CPAP-unit and the humidifying apparatus are so designed that they can be reliably and securely coupled. That arrangement preferably also entails coupling of the duplicate or secondary tube connecting device provided on the humidifying apparatus, to a connecting device provided on the CPAP-unit.

**[0038]** Independently of the measures described hereinbefore or also advantageously in combination therewith, the above-identified object in accordance with the invention is also attained by an apparatus for humidifying a respiratory gas comprising a liquid storage space for storing a liquid, a humidifying region for loading the respiratory gas with the liquid by the respiratory gas coming into contact in the humidifying region with the liquid, a respiratory gas supply device for supplying the respiratory gas to the humidifying region and a respiratory gas withdrawal device for withdrawal of the humidified respiratory gas from the humidifying region, wherein the liquid storage space is formed by a housing portion which is coupled to a trough element to form the humidifying region and there is provided a support or installation housing portion for receiving a unit formed by the housing portion and the trough element.

**[0039]** In terms of a CPAP-unit the object as set forth in the opening part of this specification is attained by a CPAP-unit comprising an outer housing, a conveyor device accommodated in the outer housing for conveying a respiratory gas to a respiratory gas outlet connection, a pressure-detection device, a control device for controlling the conveyor device in dependence on the detected pressure and a pressure-measuring connection for the connection of a pressure-detection conduit, wherein the respiratory gas outlet connection and the pressure-measuring connection are of a complementary configuration to connecting members provided on the humidifier side.

**[0040]** That advantageously affords a CPAP-system of a modular structure, which can be easily and quickly configured according to the respective requirements involved, even by a lay person. The CPAP-unit system according to the invention is also distinguished, in a completely dismantled condition, by a high level of complexity and in addition can be transported in the form of a stable unit.

**[0041]** The invention further concerns a respiration tube connecting device for coupling a respiration tube formed from a flexible material to a CPAP-unit and a respiration tube provided with a corresponding connecting device.

**[0042]** Respiration tubes of that kind are used in particular in the therapy of sleep-related respiration disturbances. In that situation the respiratory gas is supplied to a patient under a predetermined increased pressure which possibly alternates during a respiration cycle, to provide for a pneumatic splinting effect for the upper respiratory tracts.

**[0043]** To control the respiratory gas pressure, it is known to detect by way of a pressure-measuring tube the pressure in the region of a respiratory mask or in a region which is preferably spaced therefrom by between about 10 and 15 times the inside diameter of the respiratory gas tube. That pressure-measuring tube is usually inserted into the respiration tube.

**[0044]** The respiration tube can be fitted directly or by way of an elastic connecting plug sleeve on to a connecting projection provided on a CPAP-unit. In that case the pres-

sure-measuring tube is either fitted by plugging engagement on to a tube portion provided in coaxial relationship in the interior of the connecting projection or it is passed out of same by way of a small hole provided in the respiration tube and fitted in plugging engagement separately on to a corresponding pressure-detection connecting projection provided on the CPAP-unit. The known respiration tube connecting structures with integrated connecting members for a pressure-measuring tube involve the problem of a comparatively high level of respiratory resistance and difficulties in cleaning. Systems with a pressure-measuring tube which is passed freely out of same suffer from the problem that the connection of the pressure-measuring tube is forgotten under some circumstances so that this can result in an unacceptably high rise in pressure in terms of the respiratory gas feed.

**[0045]** Having regard to those circumstances and in accordance with a further concept of a way of attaining the object of the invention, there is provided a robust respiration tube system which is easy to handle and which is distinguished by involving a comparatively low level of respiratory resistance and with which correct coupling of the respiration tube to a CPAP-unit is guaranteed even without particular attention being paid.

**[0046]** In accordance with the invention that is attained by a respiration tube connecting apparatus having a base body, a respiratory gas passage duct formed in the base body, and a respiration tube connection portion for receiving an end portion of a respiration tube, which is distinguished in that provided in the base body in a region which is radially displaced with respect to the center of the respiratory gas passage duct is an additional coupling portion for coupling of an additional hose conduit to a complementary connecting structure provided on a respiratory gas source.

**[0047]** The base body is preferably formed from an elastomer material, whereby it is possible to provide for particularly reliable sealing integrity with the complementary connecting structure and adequate fixing of the plug connection.

**[0048]** The above-mentioned tube conduit connected to the additional coupling portion generally involves a pressure-measuring conduit. That additional tube conduit however may also be in the form of an analysis conduit for taking a respiratory gas sample or in the form of a flushing conduit for the exchange of consumed respiratory gas or also in the form of a feed conduit for example for oxygen.

**[0049]** In accordance with a particularly preferred embodiment of the invention the passage cross-section of the respiratory gas passage duct substantially corresponds to the passage cross-section of the respiration tube. That advantageously ensures that the connecting plug does not contribute to a considerable degree to an increase in respiratory resistance.

**[0050]** The respiratory gas passage duct is preferably of a substantially circular cross-section and can be fitted with an easy press fit on to a connecting projection provided at the unit. Preferably the respiratory gas passage duct is of such a configuration, in its region which can be pushed on to the connecting projection, that the inside wall of the connecting projection adjoins substantially steplessly the inside wall of the following region of the respiratory gas passage duct.

**[0051]** The additional coupling portion is preferably formed by a cylindrical bore portion which is provided in the base body and which extends substantially parallel to the longitudinal center line of the respiratory gas passage duct.

The inside diameter of the respiratory gas passage duct is preferably in the region of between 15 and 24 mm, preferably 19 mm—the inside diameter of the additional coupling portion is in the region of between 3 and 8 mm, preferably being 4 mm.

**[0052]** An embodiment of the invention which is particularly advantageous in terms of handling is preferably afforded if extending in the interior of the base body is a duct portion which leads from the additional coupling portion into the respiratory gas passage duct. The duct portion is preferably of a cross-section which is sufficient to receive the additional tube conduit.

**[0053]** Advantageously the additional tube conduit is inserted into the duct portion in sealing relationship, preferably being secured therein by adhesive. The additional tube conduit is preferably passed through the duct portion as far as a front end of the base body and introduced into the coupling portion.

**[0054]** A respiration tube fixing portion is advantageously formed in a region which is remote from the front end of the base body, wherein the respiration tube is fixed in the respiration tube fixing portion in sealing relationship, in particular being secured therein by adhesive or vulcanisation. As an alternative thereto or also in combination with those measures, it is also possible to provide in the respiration tube fixing portion a zone with a female screwthread, which is complementary in shape to the outside peripheral surface of a respiration tube which has a spiral insert.

**[0055]** In accordance with a preferred embodiment of the invention, towards the respiration tube, the inside region of the respiratory gas passage duct is also of such a configuration as to provide a substantially stepless transition into the respiration tube. That also achieves an effective reduction in respiratory resistance.

**[0056]** A particularly secure and load-bearing coupling between the respiration tube and the connecting plug structure is achieved by the base portion being injection-molded to the respiration tube and/or the additional tube conduit. The base body is preferably formed from an in particular transparent or translucent elastomer material, in particular silicone rubber.

**[0057]** The described connecting structure advantageously provides a respiration tube for a CPAP-unit, with a tube body which is formed from a flexible material, a pressure-measuring tube which is guided in the tube body, and a connecting plug structure provided at the end of the tube body, wherein the connecting plug structure is formed from an elastomer material and provided in the connecting plug structure is a duct portion by way of which the pressure-measuring tube is passed out of a respiratory gas conduit region into a coupling portion which is disposed laterally beside a respiratory gas conduit portion.

**[0058]** The region of the connecting plug structure which accommodates the coupling portion preferably projects in a nose-like configuration radially beyond an outside peripheral surface of the respiration tube connecting portion, whereby it is possible to achieve particularly effective pre-positioning of the plug.

**[0059]** For the treatment of sleep-related respiratory disturbances it is known to feed a patient with a respiratory gas which is optionally humidified, under a predetermined increased pressure. In that respect, in most cases the provision of the respiratory gas under an increased pressure is effected by way of blowers which are regulated in respect of

their rotary speed. Those blowers are usually accommodated in a preferably sound-insulated housing portion and are connected to a conduit system which leads to a humidifying device or directly to a coupling portion for the connection of a respiration tube. That coupling portion is generally in the form of a short tube connecting projection portion on to which the respiration tube can be fitted in sealing relationship.

**[0060]** Particularly in the case of CPAP-units for affording comparatively high respiratory gas pressure levels, it has been found to be advantageous to detect the instantaneous pressure in the respiration tube or within a respiration mask. That purpose is usually implemented by using a pressure-measuring tube, by way of which the pressure to be monitored is taken off at a defined measuring location and fed to a pressure transducer which for example is integrated into the CPAP-unit. In that case the pressure-measuring tube is fitted in sealing relationship on to a connecting projection, in a similar manner to the respiration tube. Compatibility problems frequently arise here, having regard to the large number of widely used respiration tube, pressure-measuring tube and humidifying systems.

**[0061]** In accordance with a further concept of the invention that is attained by a connecting structural component for a CPAP-unit having a tubular respiration gas conduction device whose passage cross-section substantially corresponds to the passage cross-section of a respiration tube provided for connection thereto, and a pressure-measuring tube connecting device for the connection of a pressure-measuring tube, wherein the respiration gas conduction device and the pressure-measuring connecting device are arranged in mutually juxtaposed relationship.

**[0062]** It is advantageously possible in that way for a conventional respiration tube, a conventional pressure-measuring tube or also a respiration tube with a combination plug assembly, to be connected to the correspondingly designed CPAP-unit.

**[0063]** The respiratory gas conduction device is preferably formed by a tube connecting projection whose inside diameter substantially corresponds to the inside diameter of a respiration tube. The pressure-measuring tube connecting device is also preferably formed by a tube connecting projection. Particularly effective protection for the two tube connecting projections is afforded by the two tube connecting projections being arranged in sunk relationship in an opening.

**[0064]** A particularly robust embodiment of the invention which is advantageous from production-engineering points of view is afforded if the pressure-measuring tube connecting device and the respiratory gas conduction device are of an integral construction.

**[0065]** In accordance with a particular aspect of the present invention the connecting, structural component is provided with a plate portion, wherein the respiratory gas conduction device passes through the plate portion. That plate portion preferably forms a labyrinth cover means coated with a sound-insulating soft material. That soft material advantageously acts at the same time as a sealing means between adjacent portions of the labyrinth.

**[0066]** A further embodiment of the invention which is advantageous from production-engineering points of view is afforded if both tube connecting projections extend substantially perpendicularly from the plate portion. The connecting structural component in that case can be in a particularly

advantageous manner in the form of a plastic material injection molding with tube portions which are formed integrally, that is to say in one piece, on the plate portion. [0067] The plate portion is advantageously provided with a sealing device for fitting the structural component on to a labyrinth casing in sealing relationship. A plug connecting device is advantageously provided for fixing the connecting structural component, in particular for fixing the structural component to a bottom structure of a CPAP-unit.

#### BRIEF DESCRIPTION OF THE DRAWINGS

[0068] Further details and features of the invention will be apparent from the description hereinafter of a preferred embodiment of the invention with reference to the drawing in which:

[0069] FIG. 1 shows an assembly comprising a CPAP-unit and a humidifying apparatus which can be laterally coupled directly to the front or end thereof,

[0070] FIG. 2 is a simplified sectional view to explain the modular structure of the CPAP-assembly shown in FIG. 1,

[0071] FIG. 3 is a simplified view in longitudinal section through a humidifying apparatus according to the invention,

[0072] FIG. 4 is a simplified view in section taken perpendicular to the section line A-A in FIG. 3,

[0073] FIG. 5 is a perspective view of the humidifying apparatus of FIGS. 3 and 4 viewing on to the plug connecting arrangements provided for connection to a CPAP-unit,

[0074] FIG. 6a is a perspective view of a CPAP-unit with a connecting structure which is complementary to the humidifying apparatus,

[0075] FIG. 6b shows a perspective view of the humidifying apparatus of FIG. 5 but viewing on to the connecting structures at the respiration tube side,

[0076] FIG. 7 is a simplified view in axial section through an end portion of a respiration tube and associated connecting device,

[0077] FIG. 8a is a front view of the base body of the connecting device,

[0078] FIG. 8b is a side view of the respiration tube with connecting device mounted thereto,

[0079] FIG. 9 is a simplified view in section to illustrate a suitable complementary connecting structure on the unit,

[0080] FIG. 10 shows a perspective view of a structural component in accordance with a preferred embodiment of the invention, and

[0081] FIGS. 11a, 11b, 11c show three different compatible connecting options.

#### DETAILED DESCRIPTION OF PREFERRED EMBODIMENTS

[0082] The apparatus arrangement shown in FIG. 1 includes a CPAP-unit here generally identified by reference numeral 1 and a humidifying apparatus 2 which can be connected thereto in modular relationship. Here the CPAP-unit 1 has a substantially block-shaped or box-shaped housing 3 which has a front end face 4, two side faces 5, 6 which are arranged in pairs in mutually opposite relationship and which are in substantially parallel relationship with each other, and a rear side 7 which is arranged in the rearward region of the housing 3 in relation to the front end face 4, as well as an upper top face 8. Provided in the region of the front end face 4 is a connecting device 9 which, in the embodiment illustrated here, has a respiratory gas connect-

ing portion 10, a pressure-measuring tube connecting portion 11 and an electrical connecting device 12. The respiratory gas connecting portion 10 and the pressure-measuring tube connecting portion 11 are arranged recessed substantially completely in an opening 13 which is only indicated here. The contact elements of an electrical connecting device 12 are also accommodated in an opening or recess so that those connecting members also do not project or do not project substantially beyond a surface defined by the front end face 4.

[0083] In the embodiment illustrated here the front end face 4 is of a slightly curved configuration, thereby affording particularly effective assistance in terms of centering the humidifying apparatus 2. The respiratory gas connecting portion 10 and the pressure-measuring tube connecting portion 11 are oriented in such a way that they extend substantially parallel to the joining direction which is indicated in simplified form by the arrow 14.

[0084] In its bottom region the CPAP-unit 1 has support or erection members (here support feet 15) which are such that the connecting members of the connecting device 9 are held at a predetermined vertical heightwise level which is matched precisely to the corresponding heightwise level of the connecting members of the humidifying apparatus 2.

[0085] The humidifying apparatus 2 includes a base body 16 and a liquid storage container 17 which is accommodated therein. The liquid storage container 17 can be removed from the base housing 16 for example for refilling it with humidifying liquid. The base housing has a connecting surface portion 18 which is of a correspondingly complementary configuration to the front end face 4 of the CPAP-unit 1 and in which are disposed the connecting members described in greater detail hereinafter with reference to FIG. 2.

[0086] On a side which is in opposite relationship to the connecting surface portion 18 the base housing 16 is again provided with connecting members which in terms of their structure and their arrangement substantially correspond to the connecting device 9 which has already been described with reference to the CPAP-unit 1. In that way it is then possible for the hose connecting plug provided for example for connection to the CPAP-unit 1 also to be connected directly to the humidifying apparatus 2. In that case connection of the pressure-measuring tube is achieved at the same time.

[0087] The humidifying apparatus 2 also has support feet 20 which provide that the connecting members on the humidifying apparatus in the region of the connecting surface portion 18 are held at a vertical heightwise level which corresponds to that of the connecting device 9.

[0088] As can be clearly seen from FIG. 2 the connecting device 9 on the CPAP-unit 1 is of a complementary configuration to the connecting device 21 on the humidifying apparatus 2. As indicated by the arrows 22 the two connecting devices 9 and 21 can be moved into the joined position in relation to each other. Particularly effective pre-positioning of the connecting members, in particular the respiratory gas connecting portion 10 and the corresponding counterpart portion 23, is achieved in this embodiment by the counterpart portion 23 also being centered by the inside wall 24 of the opening 13. The respiratory gas connecting portion 10 and the counterpart portion 23 on the humidifying apparatus 2 are disposed at exactly the same vertical heightwise level. Provided on the output side of the humidifying apparatus is

a connecting structure which in terms of its essential dimensions corresponds to the connecting structure provided on the CPAP-unit. The respiration tube connecting plug **25** illustrated here can thus be coupled if required directly to the CPAP-unit **1** or to the humidifying apparatus **2**. By virtue of a pressure-measuring connecting conduit which is indicated into the humidifying apparatus, a communication is afforded between the pressure-measuring tube **26** and the pressure-measuring tube connecting portion **11**, when the respiration tube connecting plug **25** is connected to the humidifying apparatus **2**. The CPAP-apparatus arrangement described hereinbefore with reference to FIGS. **1** and **2** can be used as described in the following example of use.

**[0089]** It is firstly assumed that the CPAP-unit **1** is already set up on a table top, and now the respiratory gas being conveyed by the CPAP-unit **1** is to be humidified.

**[0090]** For that purpose, as indicated in FIG. **1**, the humidifying apparatus according to the invention is also set up on the table top and is fitted on to the CPAP-unit in a joining direction which is parallel to the surface of the table and substantially perpendicular to the front end face of the CPAP-unit **1**. When that is done, the connecting devices **9** and **21** which are provided on the CPAP-unit **1** and the humidifying apparatus **2** come together in the joining position. In addition, a voltage supply to a heating device provided on the humidifying apparatus **1** is also afforded by way of an electrical connecting device **12** which is only shown in FIG. **1**. As soon as the two connecting devices **9**, **21** have moved completely into the joined position, the two modules are fixed in that joined position by a latching device (not shown) so that the humidifying apparatus **2** is reliably coupled to the CPAP-unit. The respiratory gas tube which is originally connected directly to the CPAP-unit **1** and which has an integrated pressure-measuring conduit can be connected directly to the humidifying apparatus by way of the respiratory gas connecting plug identified by reference numeral **25** in FIG. **2**. That also affords a corresponding coupling between the pressure-measuring tube **26** and the pressure-measuring tube connecting portion **11** provided on the CPAP-unit **1**.

**[0091]** For the purposes of introducing humidifying water into the liquid storage container **17**, the latter is removed from the base housing **16** of the humidifying apparatus. After the liquid storage container is filled it can be fitted into the base housing **16** again. The CPAP-apparatus system formed from two modules which can be laterally coupled, with a refilling unit which can be removed cartridge-like, is now ready for operation.

**[0092]** The view in FIG. **3** shows a longitudinal section through an apparatus for humidifying a respiratory gas (referred to hereinafter as the humidifying apparatus), in accordance with a preferred embodiment of the invention. Here, the illustrated embodiment of the humidifying apparatus includes a refilling unit **203** which is formed from a trough element **201** and a cup portion **202** coupled thereto and which can be easily removed from a support or installation housing **204** which here is of a multi-part nature.

**[0093]** The trough element **201** and the cup portion **202** are coupled together in sealing relationship. The trough element **201** and the cup portion **202** are coupled by way of a sealing structure **206** which, in the embodiment illustrated here, has a first sealing ring **207** and a second sealing ring **208**. The two sealing rings **207** and **208** are accommodated in peripheral grooves provided in a separating element **209**.

The separating element **209** has a separating wall **205** which is here of an integral nature. The separating wall **205** separates the internal region of the cup portion **202** from the internal region of the trough element **201**.

**[0094]** Formed in the cup portion **202**, in conjunction with the separating wall **205**, is a liquid storage space **210** in which initially the predominant part of the liquid provided for humidifying the respiratory gas is stored. Formed in the trough element **201** arranged beneath the cup portion **202** is a separate humidifying region in which only a partial amount of the humidifying liquid is accommodated. The level *a* of the liquid accommodated in the trough element **201** is maintained at a predetermined filling height by way of a quantitative control device. In the course of gradual consumption of the fluid in the trough element **201**, fluid is supplied as a make-up flow successively or continuously from the liquid storage space **210**. A preferred embodiment of a quantitative control device which is provided for that purpose will be described in detail hereinafter with reference to FIG. **3**.

**[0095]** Here the trough element **201** is of a substantially shell-like nature and has a respiratory gas feed opening **211** and a respiratory gas discharge opening **212**. The respiratory gas which is conveyed by a CPAP-unit (not shown here) can flow into the trough element **201** by way of the respiratory gas feed opening **211**, according to the respiration activity of a patient. By means of a direction-changing device **213** which is only shown here in simplified form the feed flow of respiratory gas is directed on to the liquid in the trough element **201**. In that situation the respiratory gas supplied thereto is enriched with moisture. The correspondingly humidified respiratory gas can then flow away, by way of the respiratory gas discharge opening **212**.

**[0096]** In the embodiment illustrated here the trough element **201** can be heated by means of a heating device **214**. The heating device **214** comprises a heating element which is arranged in the support housing **204** in such a way that the bottom region of the trough element **201** can come into intimate contact therewith. In order to increase the transmission of heat between the fluid in the trough element **201** and the heating device **214** the bottom region **215** of the trough element **201** is formed from a material of high thermal conductivity, for example metal. In the last-mentioned embodiment the above-mentioned bottom region **215** can be formed for example by the insert molding method in the actual main body of the trough element **201**. The trough element **201** is of such a configuration that it can be inserted as an easy fit in self-positioning relationship into the support housing **204**. In that case the respiratory gas feed opening **211** and the respiratory gas discharge opening are aligned with conduits or openings provided in correspondingly complementary manner in the support housing **204**.

**[0097]** In the region adjacent to the respiratory gas feed opening **211** the support housing **204** is provided with a connecting portion **216** which, in the embodiment illustrated here, can be fitted directly on to a connecting portion of a CPAP-unit, which is of a correspondingly complementary configuration. Provided in the immediate proximity of the connecting portion **216** is a further connecting portion **217** which can be coupled to a pressure-detecting connection provided on a CPAP-unit. The connecting portion **217** forms part of a conduit system which ultimately communicates with the pressure-measuring connecting portion **218** provided on an opposite side of the humidifying apparatus. In

particular a pressure-measuring tube can be connected to that pressure-measuring connection 218 for detecting the pressure in the region of the respiration hose, a gas change valve or possibly also directly in the mask region.

[0098] Beneath the pressure-measuring connecting portion 218 the support housing 204 is provided with a respiration tube connecting portion 219. The tube connecting members formed at the outlet side on the humidifying apparatus are identical to that of a CPAP-unit, in such a way that corresponding connecting tubes or hoses can be optionally connected either directly to the CPAP-unit or if necessary, when using the humidifying apparatus, only to the outlet side of the humidifying apparatus 2. Provided beneath the connecting portion identified by reference numeral 216 is a plug connecting device (not shown here) by way of which it is possible to make an electrical connection between the heating device 214 and a voltage supply device provided on the CPAP-unit. Optionally it is also possible for electrical signals, for example pressure-measuring signals, to be transmitted by way of that plug connecting device.

[0099] The support housing 204 is further provided with a fixing device 220, by way of which the humidifying apparatus can be mechanically comparatively rigidly coupled to a CPAP-unit.

[0100] A preferred embodiment of a quantitative control device for quantitative metering of the amount of fluid in the trough element 201 will be described hereinafter with reference to FIG. 4. The liquid storage space 210 and the humidifying region formed in the trough element 201 are separated from each other by way of the separating wall 205. The fluid stored in the liquid storage space 210 can be passed if required into the humidifying region by way of a fluid conduit device 221. In this case control of the make-up flow of fluid is implemented by control of the make-up introduction of air into the liquid storage space. In the embodiment illustrated here regulation of the make-up introduction of air is effected by way of a quantitative control conduit device 222 which, similarly to the above-mentioned fluid conduit device 221, passes vertically through the separating wall 205. The quantitative control conduit device 222 has a first mouth opening 223 and a second mouth opening 224. The first mouth opening 223 is arranged at the height of the desired or reference level a. As long as the first mouth opening 223 is closed by the fluid in the trough element 201, no make-up flow of air can pass into the liquid storage space 210 so that in turn no fluid can flow away out of the liquid storage space 210 by way of the fluid conduit device 221. As soon as the level a falls below the level of the first mouth opening, a make-up flow of air can pass into the liquid storage space, whereby in turn fluid can pass out of the liquid storage space 210 into the trough element 201 or the separate humidifying region formed therein. The fluid conduit device 221 has a discharge mouth opening 225 which is somewhat below the reference level identified here by the letters a.

[0101] In the embodiment illustrated here the fluid conduit device 221, the quantitative control conduit device 222 and the separating wall 205 are formed by an integral member. For the purposes of introducing the liquid into the liquid storage space, it is possible for that integral member to be withdrawn from the cup portion 202. The cup portion 202 can optionally also be provided with a corresponding refilling opening which can be sealingly closed. The cup portion 202, the integral member having the separating wall and the trough element can each be cleaned separately. The quanti-

tative control conduit device 222 is of such a design configuration that the second mouth opening 224 provided thereon is above the maximum filling level of the liquid storage space 210.

[0102] FIG. 5 is a perspective view of the humidifying apparatus described hereinbefore with reference to FIGS. 3 and 4. The cup portion which is preferably formed from a transparent material can be seen here in the form of a bowl of substantially cylindrical configuration. That bowl is fitted in a receiving portion which is also cylindrical and which is formed in the support housing 204. In the region of the cup portion 202 the support housing 204 is of such a design configuration that the cup portion can be gripped with one hand. The connecting portion 217 and the pressure-measuring connecting portion 218 which have already been described with reference to FIG. 3 are provided in the region of the rear side 226 of the humidifying apparatus. Provided beneath those connecting portions is the fixing device which is identified by reference 220 in FIG. 3 and which can provide particularly rigid coupling of the humidifying apparatus to a corresponding CPAP-unit. Provided in a receiving recess beneath the connecting portion 216 is an electrical plug connecting arrangement (not shown here) for providing an electrical connection for the heating device to the associated CPAP-unit.

[0103] Provided in the lateral region of the outer housing are switch members 227, by way of which it is possible to set on the one hand the temperature of the liquid in the trough element 201 and the switch-on time for the humidifying apparatus.

[0104] The rear side 226 of the humidifying apparatus is of a configuration corresponding to the front side of a CPAP-unit described hereinafter with reference to FIG. 6a so that the humidifying apparatus can be connected in a modular manner virtually without any intermediate space to the CPAP-unit.

[0105] The CPAP-unit shown in FIG. 6a has a substantially cuboidal housing, in the upper region of which is provided a gripping arrangement 330, by way of which the CPAP-unit can be gripped in an ergonomically advantageous manner. Provided in a front end region are connecting members 331, for the connection of at least one respiration tube or hose.

[0106] The illustrated embodiment has a respiration hose connecting projection 332 and a pressure-measuring tube connecting projection 333. The arrangement of those connecting members substantially corresponds to the arrangement of the connecting members 216 and 217 described with reference to FIG. 3. The connecting members 231 are further of such a configuration that the connecting members 216, 217 on the humidifying apparatus (FIG. 3) can be directly fitted on or fitted in. Also provided in the bottom region of the CPAP-unit are engagement structures which can be brought into engagement with engagement portions of a complementary configuration, on the humidifying apparatus. The connecting members 331 are here arranged in recessed relationship in such a way that they do not project beyond an outside surface and in particular a front surface of the housing.

[0107] FIG. 6b shows the humidifying apparatus described hereinbefore with reference to FIGS. 3, 4 and 5, viewing on to the front region thereof. The connecting portions 216 and 217 are arranged in recessed relationship, similarly as also in regard to the CPAP-unit. The connecting

portions are surrounded by a plug-receiving space 234 into which can be inserted a plug preferably formed from a soft material, in particular silicone rubber.

[0108] The plug-receiving space 234 is preferably of such a nature that a corresponding plug slides both on the respective projection 216, 217 and also along the wall of the plug-receiving space 234.

[0109] The invention is not limited to the embodiments by way of example described hereinbefore. For example it is also possible for the described humidifying apparatus to be integrated directly into a corresponding CPAP-unit. It is also possible to fit into the support housing which can be docked in a simple fashion to a CPAP-unit, refilling units which deviate in respect of their structure and the humidifying principle involved, from the described humidifying apparatus. It is also possible for the trough element of the humidifying unit to be so designed that it can be connected directly to the CPAP-unit, omitting the support or installation housing. The described humidifying apparatus can also be connected to a respiratory gas source, with the interposition of a hose conduit. The refilling unit can also be arranged in the form of a substantially trough-like unit under the CPAP-unit.

[0110] The respiration tube or hose 301 shown in FIG. 7 is provided in its end region with a connecting device 302 which here has a base body 303 formed from an elastomer material, in particular silicone rubber, with two coupling portions 304, 305 formed therein.

[0111] The two coupling portions 304, 305 are formed integrally by mutually parallel tube zones which are of circular cross-section. The inside diameter of the respective tube zone is slightly smaller than the outside diameter of the connecting projections which pass into the two tube zones when the plug is connected thereto and in that case is slightly enlarged.

[0112] Formed in the region of the base body, which is towards the hose or tube, is a fixing portion 306 in which the respiration tube 301 is fixed by way of a ring element 307. The ring element 307 is here also formed from an elastomer material and is secured by adhesive to the outside surface of the respiration tube.

[0113] An additional tube—here a pressure-measuring tube 308—is guided in the interior of the respiration tube 301. The pressure-measuring tube 308 opens into the coupling portion 305 by way of a passage duct 309 formed in the base body 303. The pressure-measuring tube 308 is secured by adhesive or vulcanisation in the base body 303. The passage duct 309 is of such a configuration that the pressure-measuring tube 308 is only slightly curved. The angle  $\alpha$  between the longitudinal center line of the coupling portion 304 and the longitudinal center line of the passage duct 309 is preferably less than 35°.

[0114] The transition of the inside wall of the pressure-measuring tube 309 into the coupling portion 305 is effected here substantially steplessly. A corresponding shoulder 310 is provided at the end of the passage duct 309, for that purpose.

[0115] The respiratory gas conduit region 311 formed in the base body 303 in this case also forms a substantially stepless transition into the inner region of the respiration tube 301.

[0116] With suitable elasticity of the tubes 301, 308, it is possible for them to be passed to the end face 312 of the base body 303 so that the coupling members on the unit side can pass directly into the tubes 301, 308.

[0117] The external configuration of the base body shown in FIG. 7 will be described in still greater detail with reference to FIGS. 8a and 8b. As can be clearly seen in particular from FIG. 8a, the coupling portion intended for the connection of the additional tube is arranged at a radial spacing from the respiratory gas conduit coupling portion 304 in a region 314 of the base body 303, which projects radially outwardly in a nose-like configuration. That provides for effective preliminary positioning of the base body in a recess provided in the unit.

[0118] That region which extends radially outwardly in a nose-like configuration decreases continuously towards the end of the base body 1, which is towards the respiration tube. Provided in the region of the end towards the tube is a peripheral bead or ridge 315, by way of which a flow of forces between the hose and the plug structure, which is advantageous from mechanical points of view, is achieved.

[0119] FIG. 9, for explanatory purposes, shows a preferred embodiment of a connecting structure on the unit, which connecting structure is of a substantially complementary configuration to the coupling portions 304, 305 provided in the base body 303 of the plug.

[0120] The projection portion which is identified here by reference 316 passes into the coupling portion 304 in the joined position of the assembly. The projection portion identified by reference numeral 317 comes into engagement with the coupling portion in the joined position. The two projection portions 316, 317 are arranged in recessed relationship in a recess 318. The inside wall which defines the recess 318, in conjunction with the external contour of the base body 303 shown in FIG. 8a, provides for pre-positioning thereof.

[0121] The connecting structural component shown in FIG. 10 includes a respiratory gas conduction device which is here in the form of a tube projection portion 401. A further tube projection portion 402 is arranged adjacent to that tube projection portion 401, leaving an intermediate space. The tube projection portion 402 forms a pressure-measuring tube connecting device. The two tube projection portions 401, 402 are arranged in recessed relationship in a recess 403. That recess is surrounded by a front cover plate 404. The cover plate 404 and the wall defining the recess 403 are formed in one piece.

[0122] In a region remote from the end of the tube projection 401, which is towards the tube, it opens into a base plate 405 which here forms a cover plate for a labyrinth arrangement. This labyrinth arrangement which is not described in greater detail here forms a prolonged respiratory gas guide path for the absorption of any odors produced by a blowing device. The base plate 405 is coated with a sound-absorbing material, in particular foam, on the rear side which is not visible here.

[0123] Provided in a region between the base plate 405 and the cover plate 404 is a connecting duct 406, by way of which the interior of the tube projection 402 can be coupled to a pressure transducer arranged on a control board.

[0124] The connecting structural component is further provided with fixing devices 407, 408, by way of which that component can be fixed in a CPAP-unit in an easily interchangeable manner.

[0125] More particularly but not exclusively the conduit devices shown in FIGS. 11a, 11b and 11c can be connected to the illustrated connecting structural component.

[0126] In this respect FIG. 11a shows a compact plug which is advantageous in terms of handling, from ergonomic points of view, with an integrated pressure-measuring tube passage configuration.

[0127] FIG. 11b shows a respiration tube 409 and a pressure-measuring tube 410 which is independent thereof, both of which can be connected without a plug arrangement directly to a corresponding CPAP-unit, by way of the connecting structural component according to the invention.

[0128] FIG. 11c is a greatly simplified view showing a coupling portion of a humidifying apparatus which can be fitted directly to a CPAP-unit by way of the structural component according to the invention. In that case the projection portion identified by reference numeral 411 engages with the tube projection 401 and the bore portion 412 with the tube projection 402.

1-20. (canceled)

21. A positive pressure gas supply system configured to supply positive pressure gas to a patient, the system comprising:

a continuous positive air pressure (CPAP) unit configured to generate a flow of positive pressure gas;

a humidifier support housing having a receiving portion, the receiving portion being bound by a bottom wall and at least one side wall extending vertically from the bottom wall, the at least one side wall comprising a gas feed opening in fluid communication with a gas feed path from the CPAP unit, the bottom wall comprising a heater;

a refilling module configured to retain a body of water and be removably placed within the receiving portion from a location above the receiving portion, the refilling module comprising a metallic portion configured to contact the heater when the refilling module is resting on the bottom wall of the receiving portion; and

a sealing device configured to seal off the refilling module in the receiving portion, the sealing device and the refilling module being removable as a unit from the humidifier support housing.

22. The system of claim 21, wherein the at least one side wall further comprises a gas discharge opening opposite the gas feed opening.

23. The system of claim 22, wherein the gas discharge opening is in fluid communication with a gas discharge path that leads to a gas outlet of the humidifier support housing.

24. The system of claim 23, wherein the gas outlet of the humidifier support housing is configured to connect to an air delivery tube.

25. The system of claim 24, wherein the refilling module is configured to complete an air path between the gas feed path and the gas discharge path when the refilling module rests on the bottom wall of the receiving portion.

26. The system of claim 25, wherein the gas feed opening and gas discharge opening are at substantially the same height.

27. The system of claim 26, wherein the refilling module comprises a direction-changing device that intervenes between the gas feed opening and the gas discharge opening when the refilling module rests on the bottom wall of the receiving portion, the direction changing device being configured to divert the positive pressure gas downward toward the bottom of the refilling module.

28. The system of claim 21, wherein the refilling module has a top portion, a bottom portion and a seal between the top and bottom portions.

29. The system of claim 28, wherein the refill module comprises an air inlet and an air outlet on the at least one side wall, the air inlet and the air outlet being configured so that the positive pressure gas enters and exits the refill module in a substantially lateral direction.

30. The system of claim 29, wherein the refill module comprises a top surface opposite the bottom and the air inlet and the outlet are between the top portion and the bottom portion.

31. The system of claim 21, wherein at least a portion of the sealing device extends around a perimeter of the refilling module.

32. The system of claim 21, wherein the sealing device configured to seal off the portion of the refilling module in the receiving portion.

33. The system of claim 21, wherein the sealing device configured to completely seal off the refilling module in the receiving portion.

34. The system of claim 21, wherein the humidifier support housing and the CPAP unit are integrated.

35. A positive pressure gas supply system configured to supply positive pressure gas to a patient, the system comprising:

a continuous positive air pressure (CPAP) unit configured to generate a flow of positive pressure gas;

a humidifier support housing having a receiving portion, the receiving portion being bound by a bottom wall and at least one side wall extending vertically from the bottom wall, the at least one side wall comprising a gas feed opening in fluid communication with a gas feed path from the CPAP unit and comprising a gas discharge opening opposite the gas feed opening, the bottom wall comprising a heater;

a refilling module configured to retain a body of water and be removably placed within the receiving portion from a location above the receiving portion, the refilling module comprising a metallic portion configured to contact the heater when the refilling module is in contact with the bottom wall of the receiving portion; and

a sealing device attachable to the refilling module in such a manner that when the sealing device is attached to the refilling module, placing the refilling module in the receiving portion seals off a part of the refilling module in the receiving portion.

36. The system of claim 35, wherein the gas discharge opening is in fluid communication with a gas discharge path that leads to a gas outlet of the humidifier support housing.

37. The system of claim 36, wherein the gas outlet of the humidifier support housing is configured to connect to an air delivery tube.

38. The system of claim 37, wherein the refilling module is configured to complete an air path between the gas feed path and the gas discharge path when the refilling module rests on the bottom wall of the receiving portion.

39. The system of claim 35, wherein the gas feed opening and gas discharge opening are at substantially the same height.

40. The system of claim 35, wherein the refilling module has a top portion, a bottom portion and a seal between the top and bottom portions.

**41.** The system of claim **35**, wherein at least a portion of the sealing device extends around a perimeter of the refilling module.

**42.** The system of claim **35**, wherein the refilling module comprises a direction-changing device that intervenes between the gas feed opening and the gas discharge opening when the refilling module rests on the bottom wall of the receiving portion, the direction changing device being configured to divert the positive pressure gas downward toward the bottom of the refilling module.

**43.** An apparatus for delivering a flow of pressurized breathable gas to a patient having a sleep-related disorder, the apparatus comprising:

a continuous positive airway pressure (CPAP) unit comprising a blower configured to generate the flow of pressurized breathable gas;

a support housing integrated directly into the CPAP unit and having a chamber with at least one side wall extending from a bottom wall, the at least one side wall comprising a gas feed opening in fluid communication with an outlet of the CPAP unit and comprising a gas discharge opening separated from the gas feed opening, the bottom wall comprising a horizontally extending heater plate; and

a refill module configured to hold a body of water and be received within the chamber, the refill module comprising an air inlet, an air outlet and a horizontally extending bottom with a metallic heat conducting material configured to intimately contact the heater plate when the refill module is received within the chamber, wherein the refill module and the support housing are configured so that insertion of the refill module in the chamber fluidly connects the gas feed opening to the gas discharge opening,

wherein the refill module is configured to be locked in place within the chamber,

wherein when the refill module is locked within the chamber, a portion of the refill module remains outside the chamber,

wherein the refilling module has a top portion a seal, the seal, the air inlet and the air outlet being between the top portion and the horizontally extending bottom,

wherein the refill module is configured to be opened by moving the top portion relative to the bottom portion, wherein the chamber is open at one end,

wherein the refill module comprises a direction-changing device configured to divert the flow of pressurized breathable gas downward toward the bottom wall of the refill module, and

wherein a respiration tube connecting portion is fixed to an external side wall of the support housing and is in fluid communication with the gas discharge opening regardless of whether the refill module is within the chamber.

**44.** The apparatus of claim **43**, wherein the refill module is configured to be opened by rotating the top portion relative to the bottom portion.

**45.** The apparatus of claim **43**, wherein the air inlet and the air outlet of the refill module are configured so that the pressurized breathable gas enters and exits the refill module in a substantially lateral direction.

**46.** The apparatus of claim **43**, wherein the refill module further comprises at least one side wall extending upward from the horizontally extending bottom, and wherein the air inlet and the air outlet comprise openings in the at least one side wall.

\* \* \* \* \*