



US 20170352670A1

(19) **United States**

(12) **Patent Application Publication**
HSIEH

(10) **Pub. No.: US 2017/0352670 A1**

(43) **Pub. Date: Dec. 7, 2017**

(54) **READ-ONLY MEMORY (ROM) DEVICE
STRUCTURE AND METHOD FOR FORMING
THE SAME**

Publication Classification

(51) **Int. Cl.**
H01L 27/112 (2006.01)
H01L 27/02 (2006.01)
H01L 27/092 (2006.01)
H01L 29/66 (2006.01)
(52) **U.S. Cl.**
CPC .. *H01L 27/11273* (2013.01); *H01L 29/66545*
(2013.01); *H01L 27/0207* (2013.01); *H01L*
27/092 (2013.01)

(71) Applicant: **Taiwan Semiconductor
Manufacturing Co., Ltd.**, Hsinchu
(TW)

(72) Inventor: **Chih-Hung HSIEH**, Hsinchu (TW)

(73) Assignee: **Taiwan Semiconductor
Manufacturing Co., Ltd.**, Hsinchu
(TW)

(57) **ABSTRACT**
A read-only memory (ROM) structure is provided. The ROM device structure includes an active region formed over a substrate and a first group of word lines formed over the active region. The first group of word lines includes at least two word lines. The ROM device structure includes a second group of word lines formed on the active region, and the second group of word lines includes at least two word lines. The ROM device structure further includes an isolation line between the first group of word lines and the second group of word lines and over the active region. The first group of word lines, the second group of word lines, and the isolation line are formed in a second metal layer.

(21) Appl. No.: **15/261,282**

(22) Filed: **Sep. 9, 2016**

Related U.S. Application Data

(60) Provisional application No. 62/344,226, filed on Jun. 1, 2016.

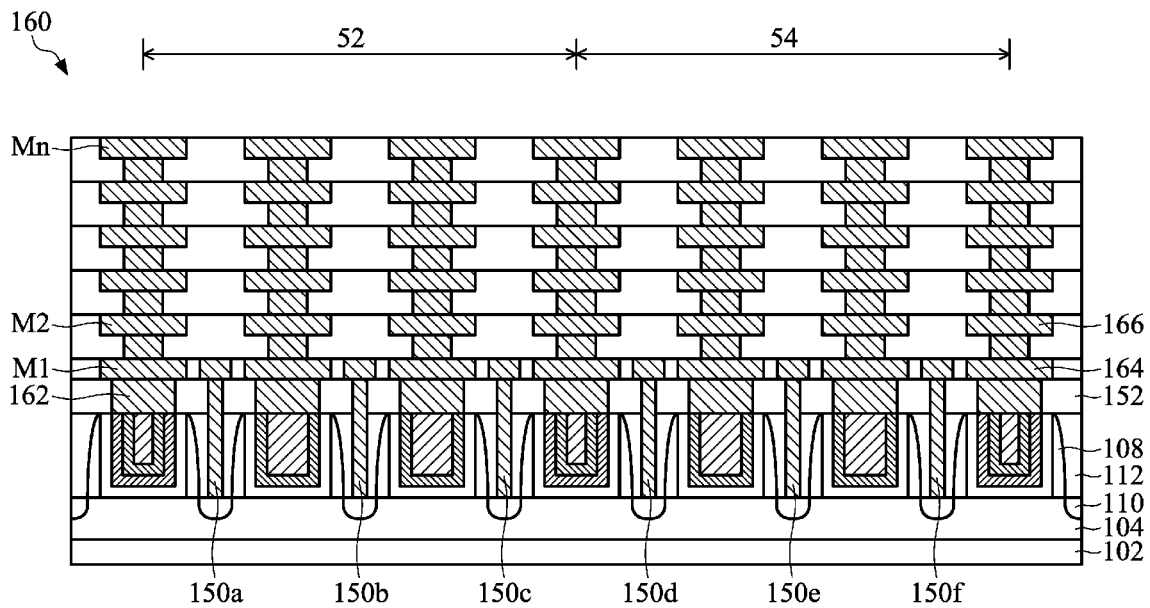

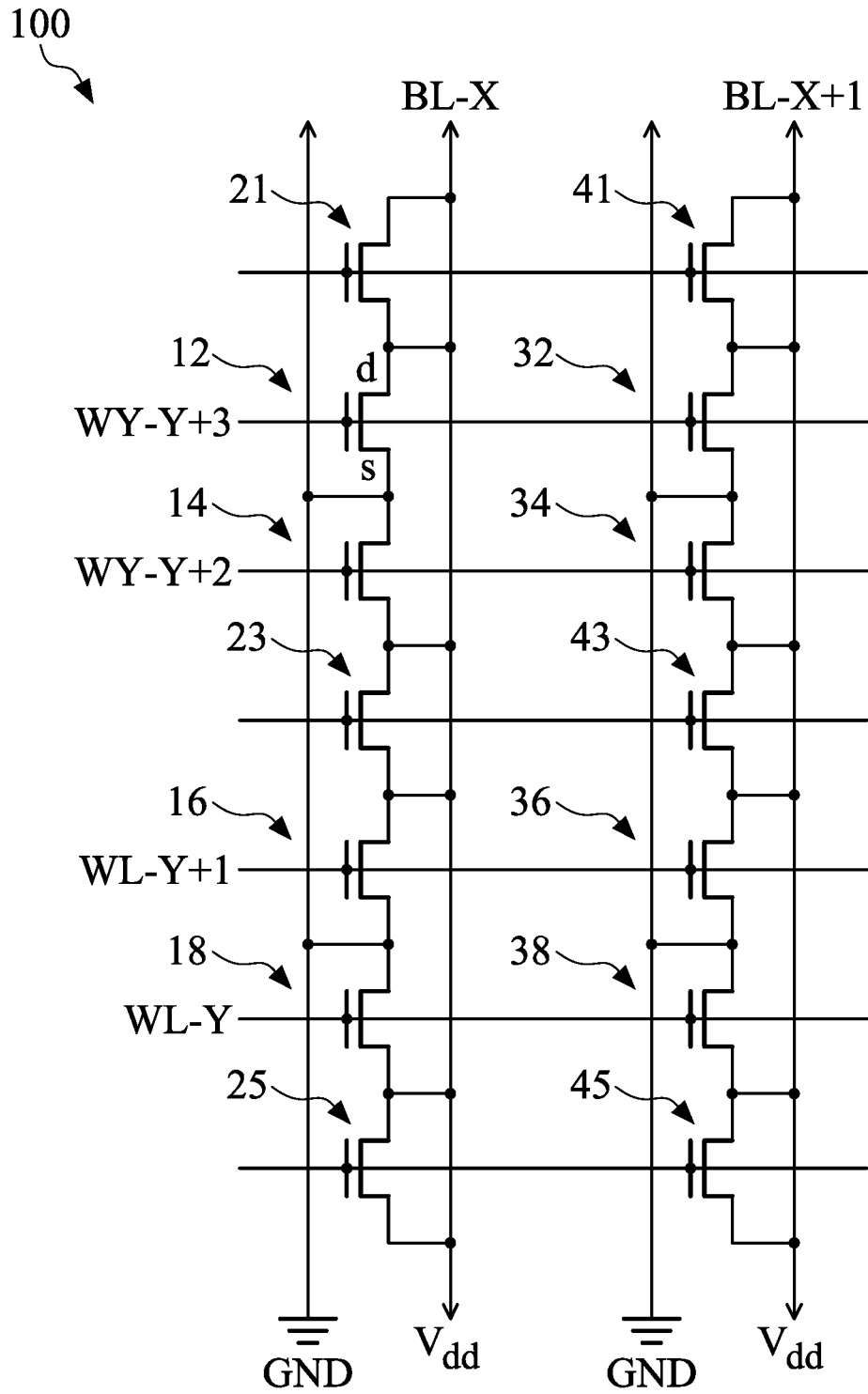

FIG. 1

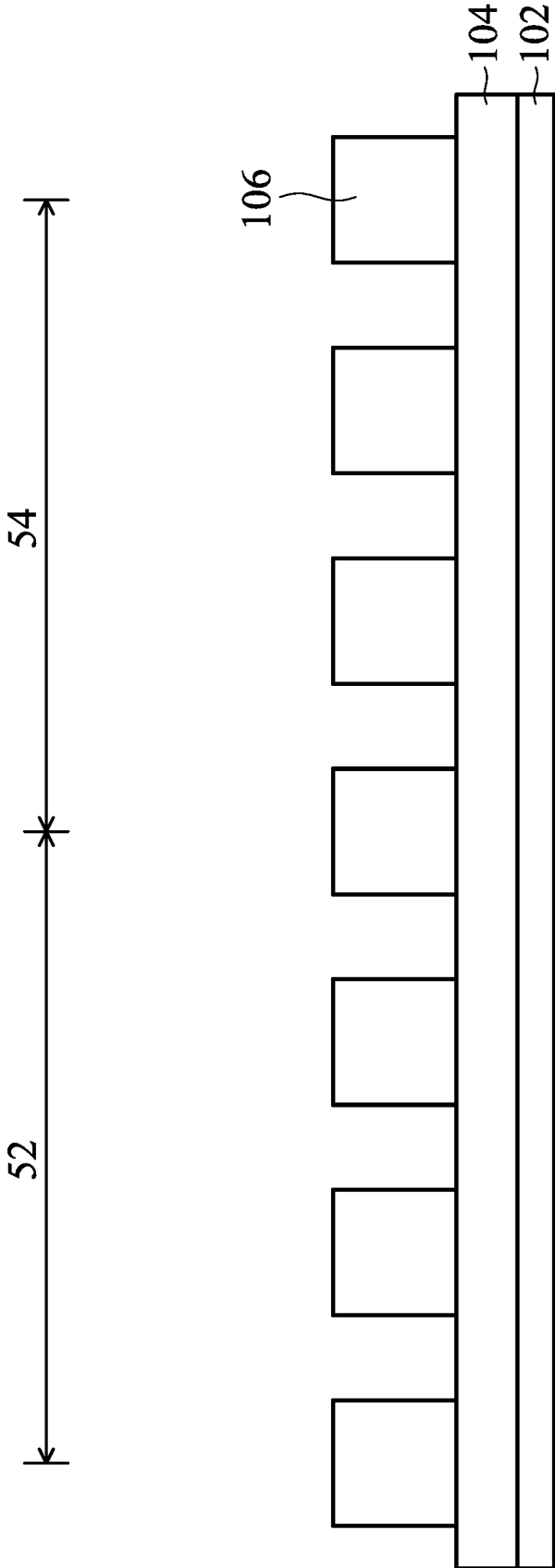

FIG. 3A

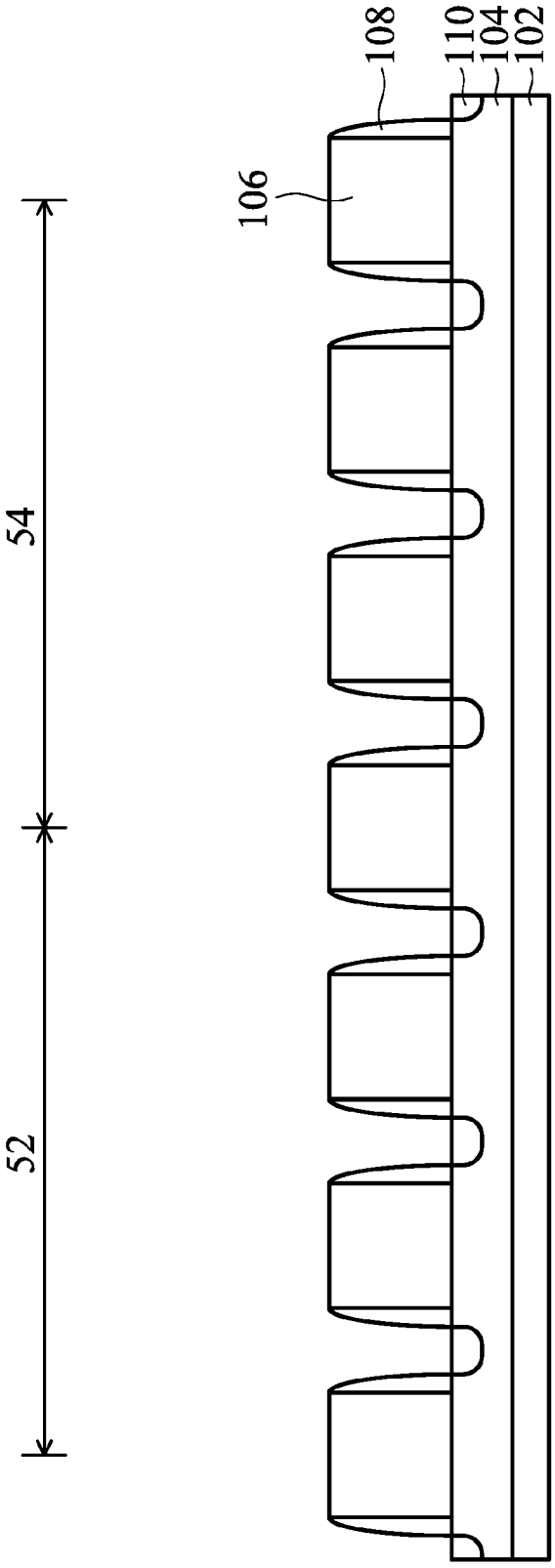

FIG. 3B

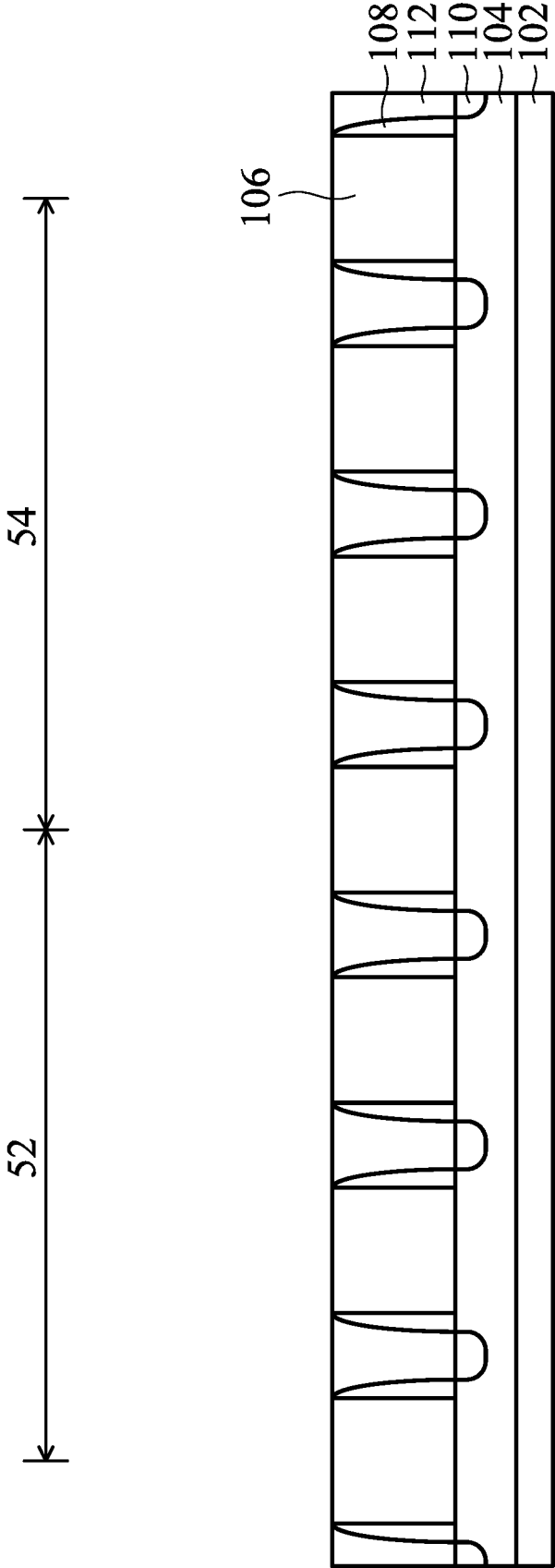

FIG. 3C

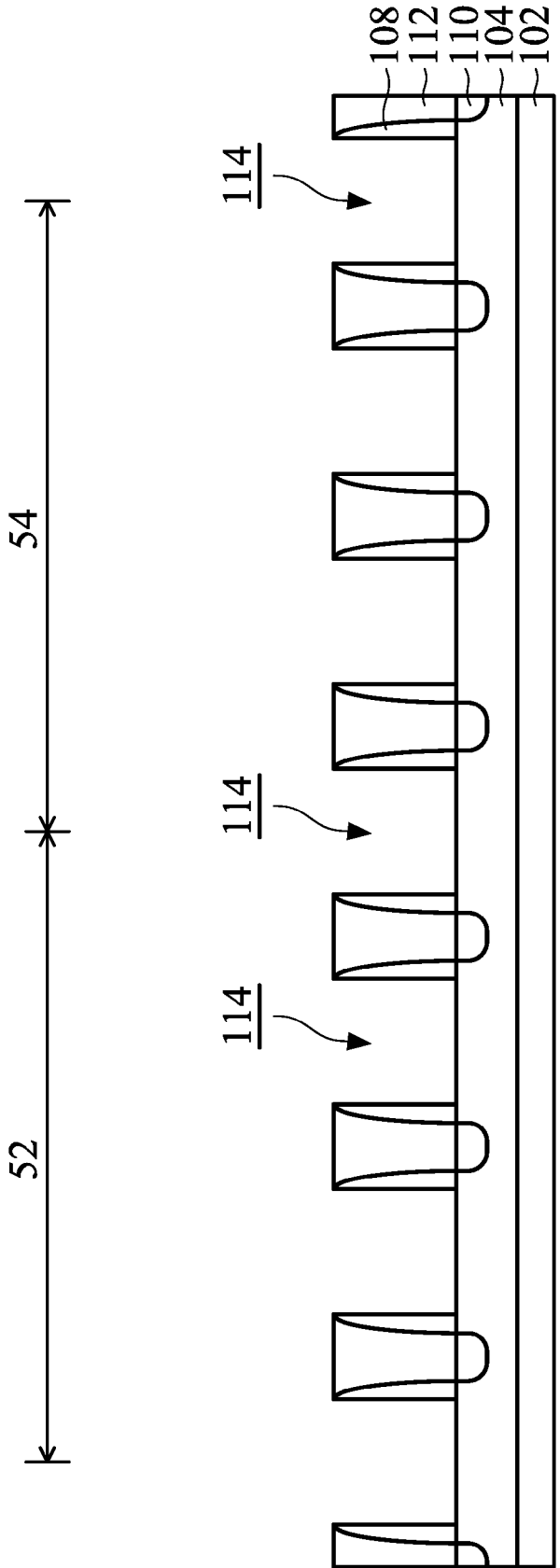

FIG. 3D

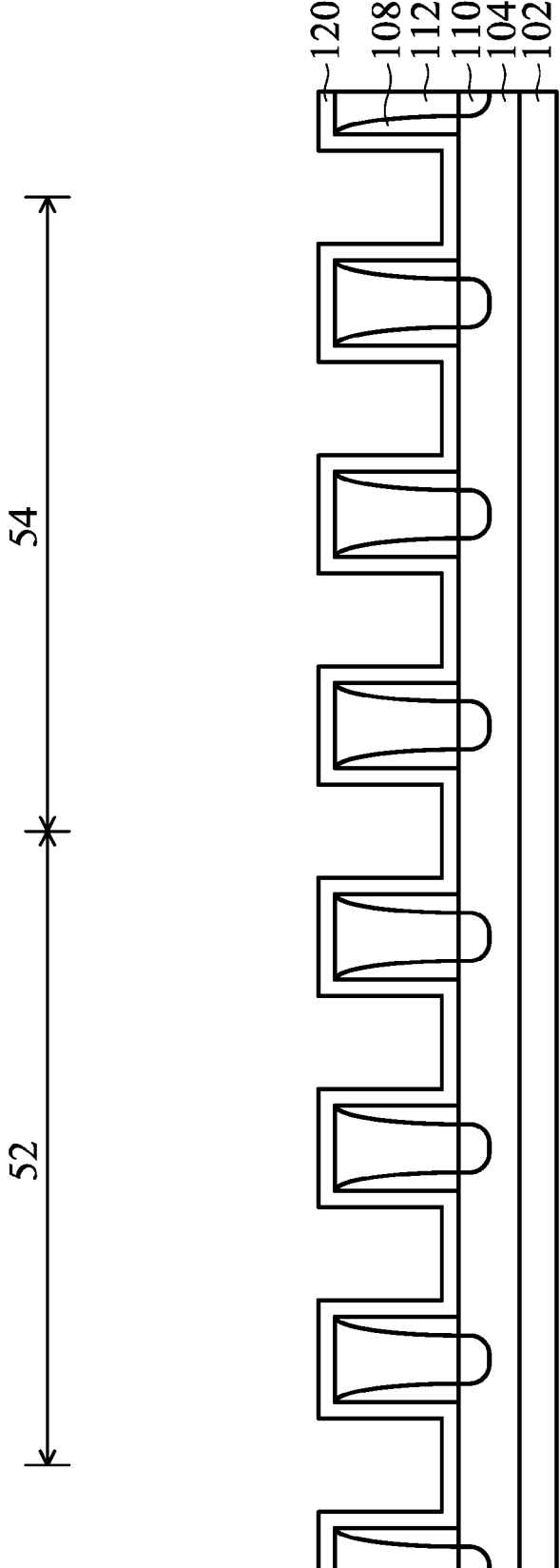

FIG. 3E

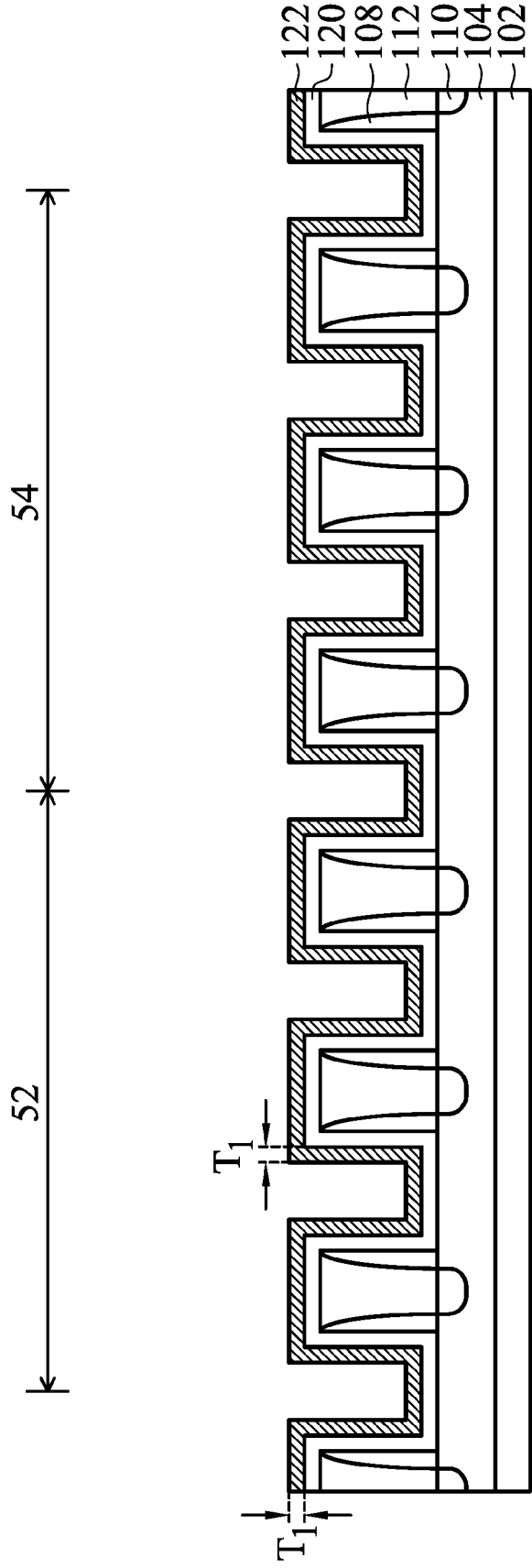

FIG. 3F

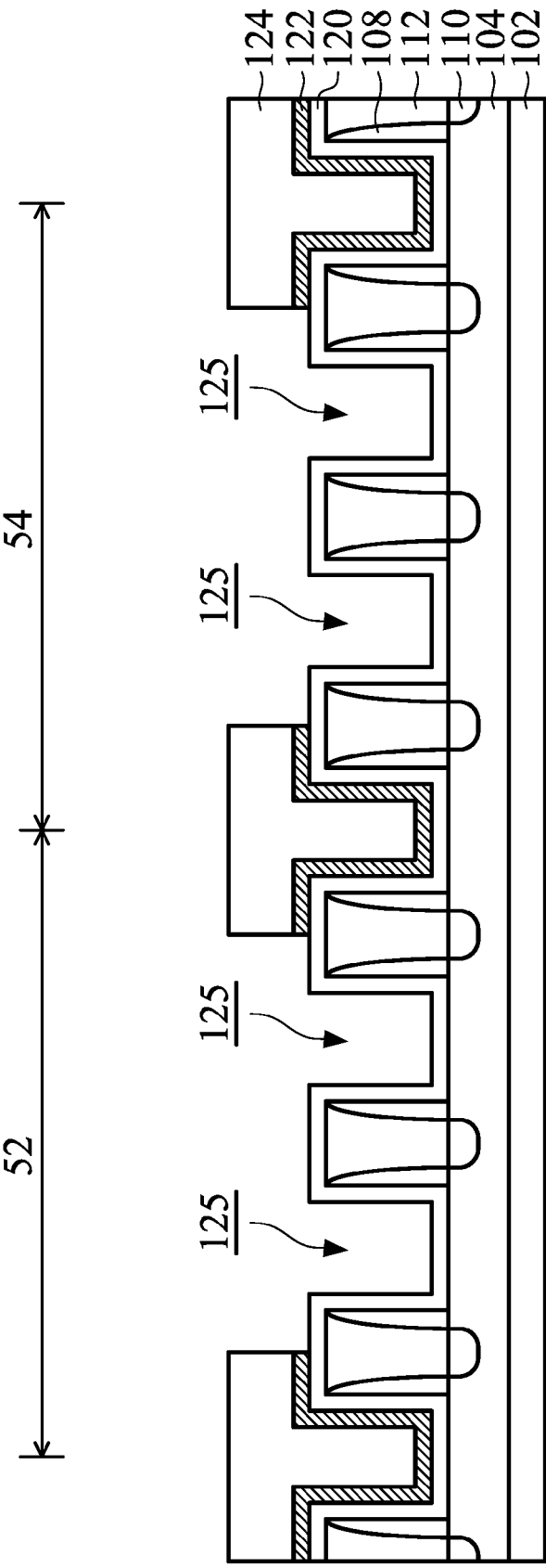

FIG. 3G

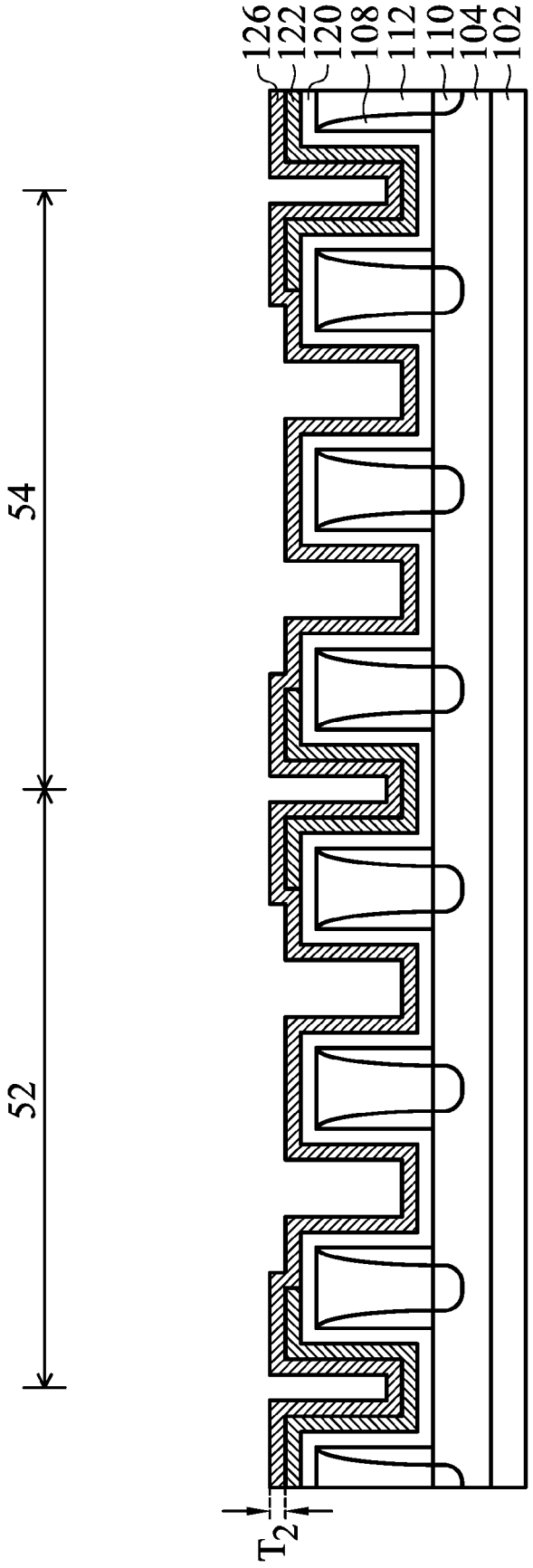

FIG. 3H

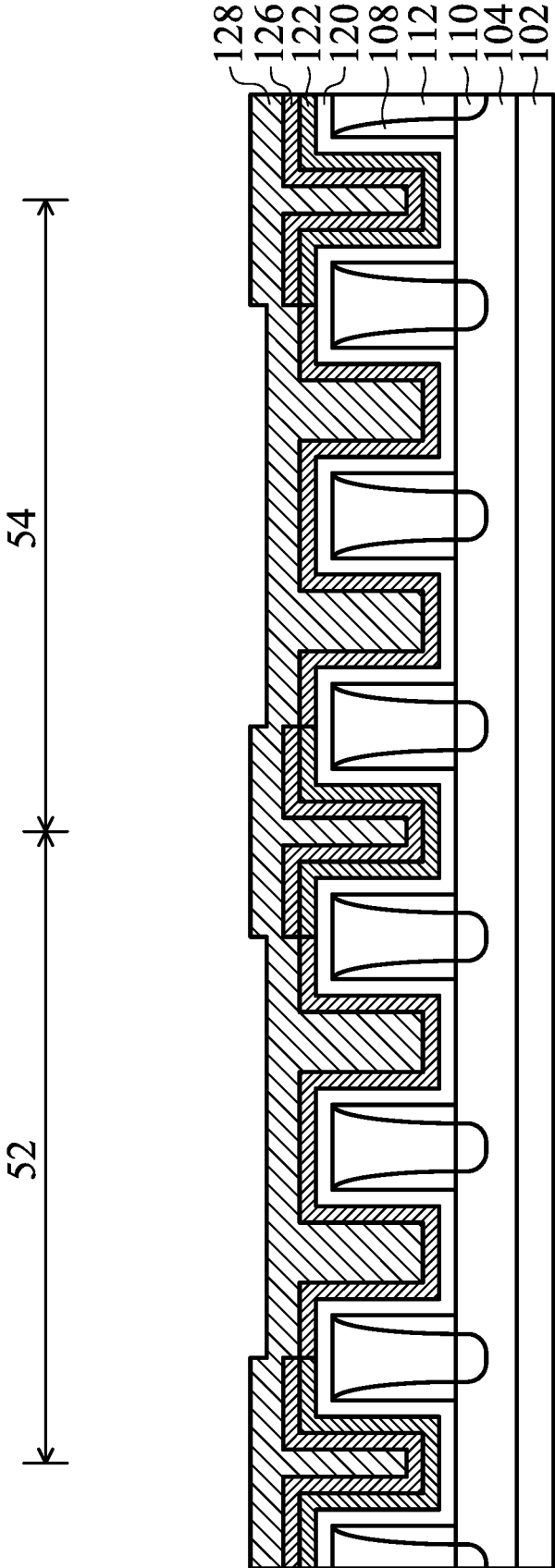

FIG. 3I

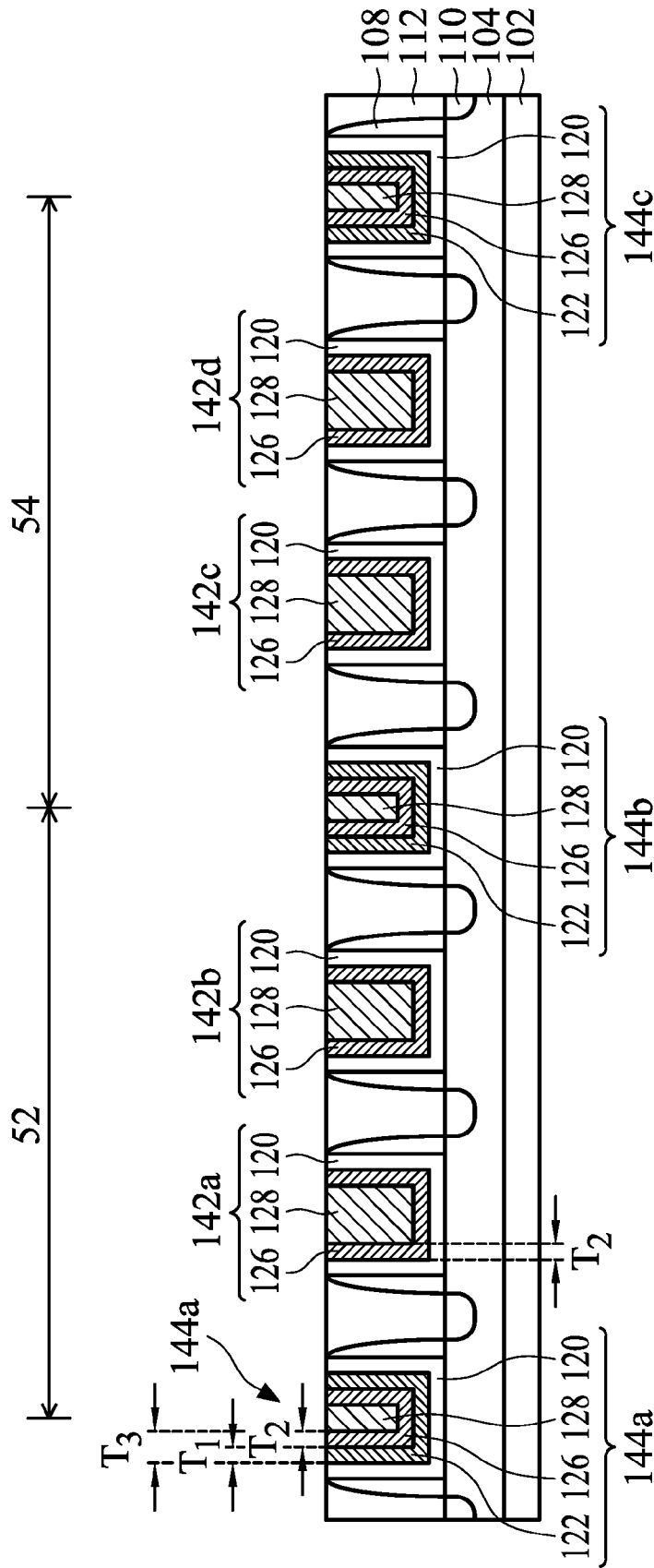

FIG. 3J

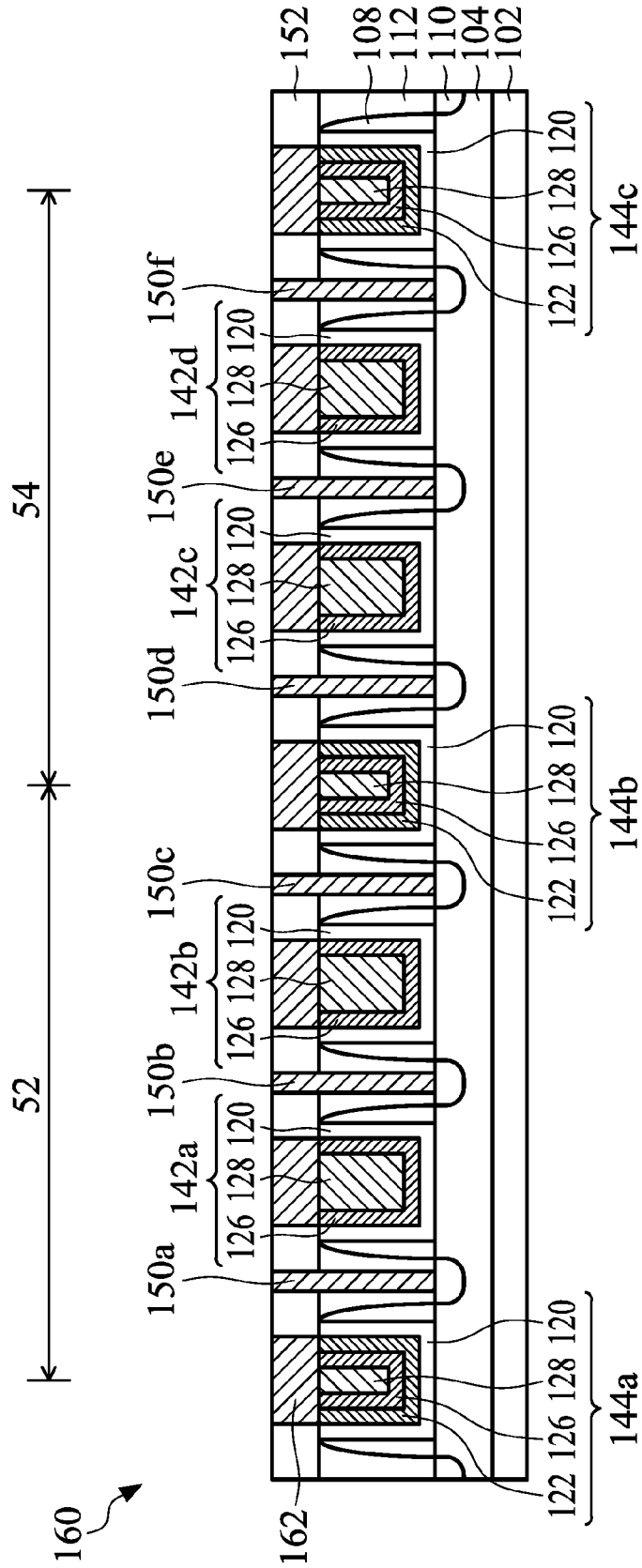

FIG. 3K

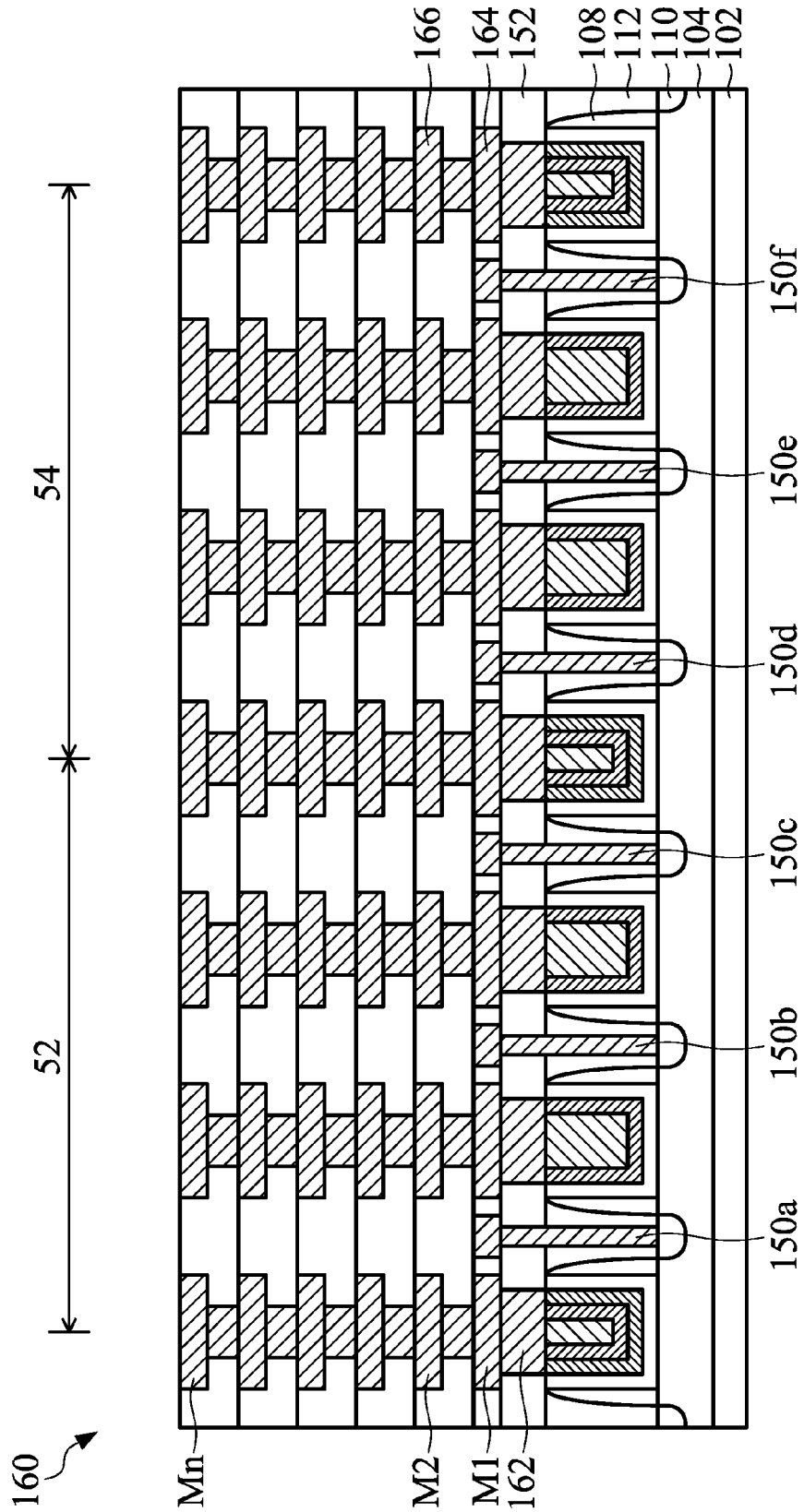

FIG. 3L

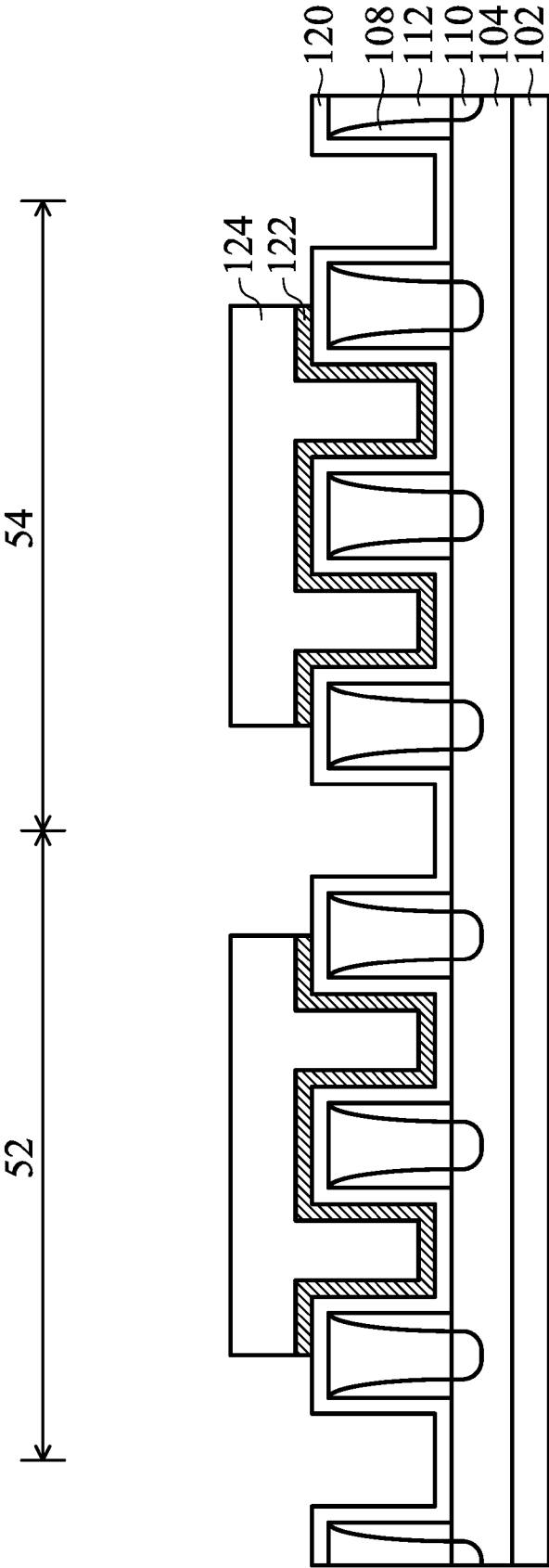

FIG. 4A

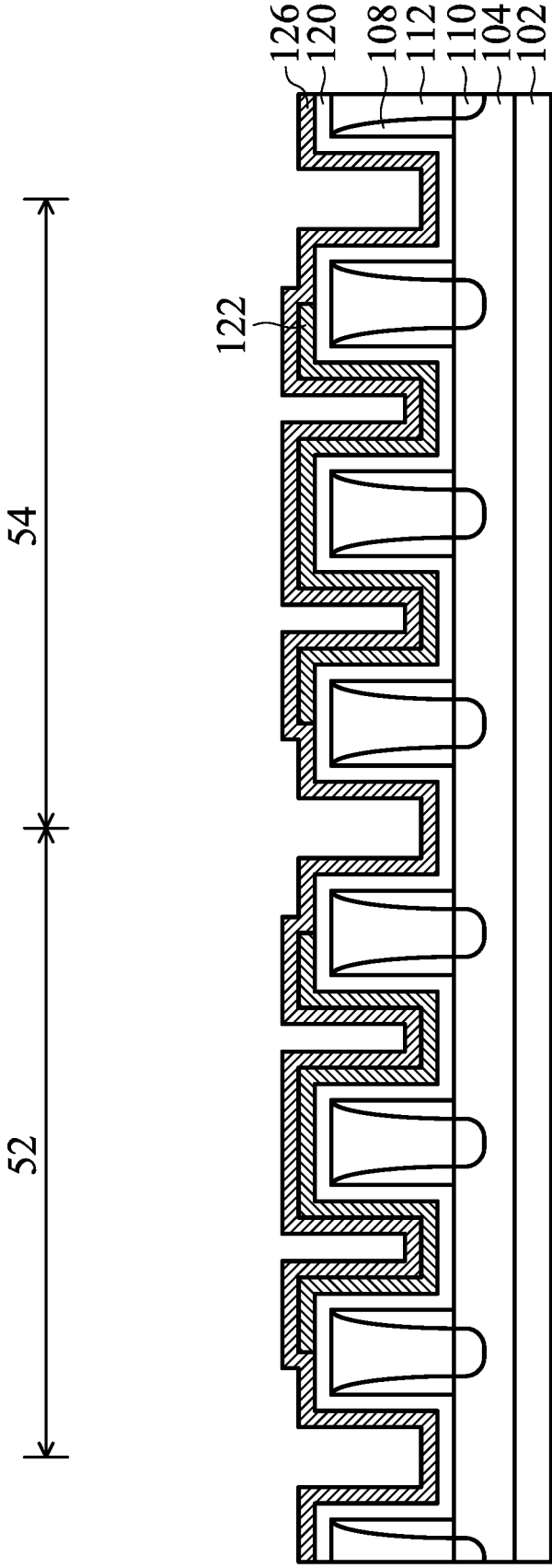

FIG. 4B

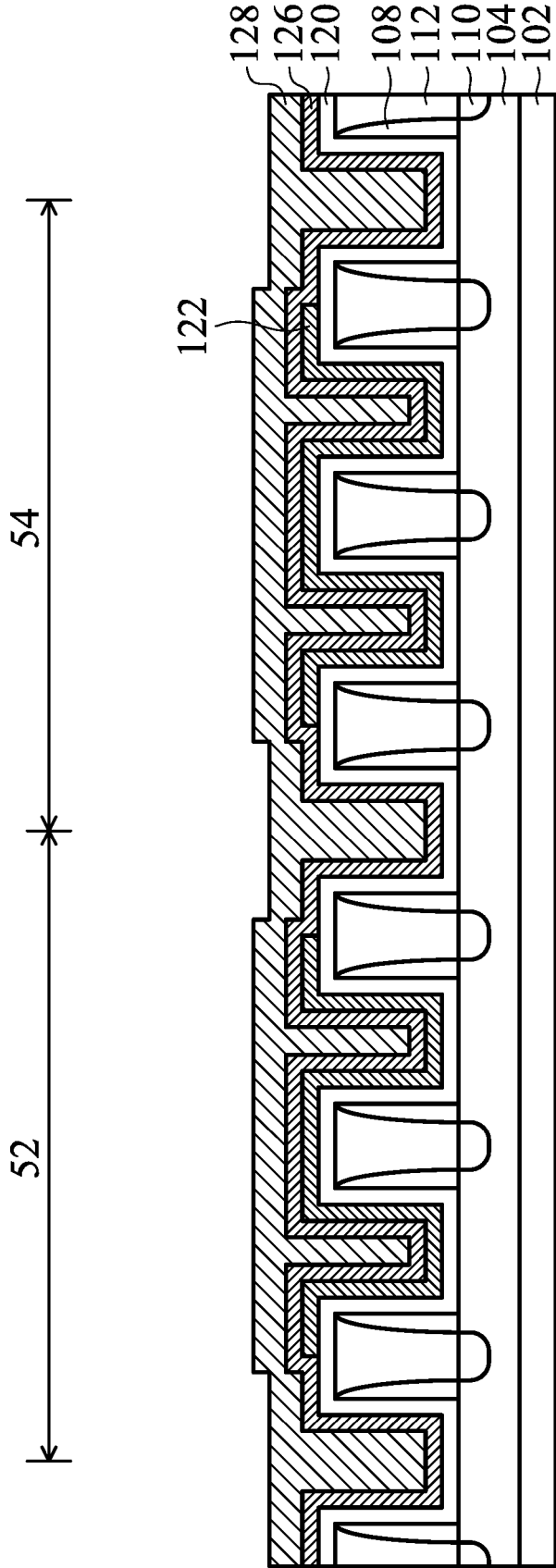

FIG. 4C

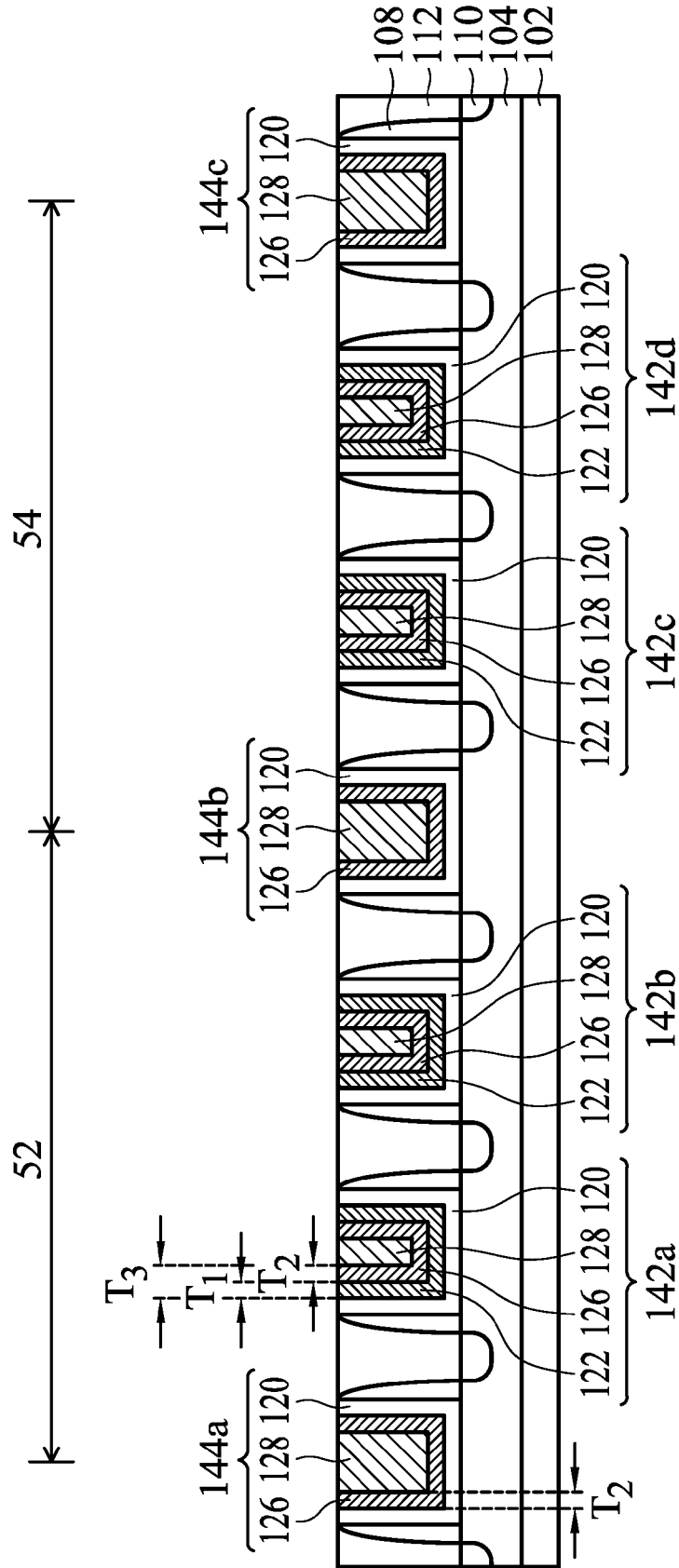

FIG. 4D

READ-ONLY MEMORY (ROM) DEVICE STRUCTURE AND METHOD FOR FORMING THE SAME

CROSS REFERENCE TO RELATED APPLICATIONS

[0001] This Application claims the benefit of U.S. Provisional Application No. 62/344,226, filed on Jun. 1, 2016, and entitled "Read-only memory (ROM) device structure and method for forming the same", the entirety of which is incorporated by reference herein.

BACKGROUND

[0002] Semiconductor devices are used in a variety of electronic applications, such as personal computers, cell phones, digital cameras, and other electronic equipment. Semiconductor devices are typically fabricated by sequentially depositing insulating or dielectric layers, conductive layers, and semiconductive layers of material over a semiconductor substrate, and patterning the various material layers using lithography to form circuit components and elements thereon. Many integrated circuits are typically manufactured on a single semiconductor wafer, and individual dies on the wafer are singulated by sawing between the integrated circuits along a scribe line. The individual dies are typically packaged separately, in multi-chip modules, for example, or in other types of packaging.

[0003] A read-only memory (ROM) device structure is a nonvolatile semiconductor memory device which is widely utilized in digital electronics applications. The data stored in the ROM device structure can be retained permanently even after the power is turned off.

[0004] Although existing ROM devices and methods of fabricating ROM devices have generally been adequate for their intended purposes, they have not been entirely satisfactory in all respects.

BRIEF DESCRIPTION OF THE DRAWINGS

[0005] Aspects of the present disclosure are best understood from the following detailed description when read with the accompanying figures. It should be noted that, in accordance with the standard practice in the industry, various features are not drawn to scale. In fact, the dimensions of the various features may be arbitrarily increased or reduced for clarity of discussion.

[0006] FIG. 1 shows a circuit diagram of a read-only memory (ROM) cell array, in accordance with some embodiments of the disclosure.

[0007] FIG. 2 shows a layout diagram of a read-only memory (ROM) cell array, in accordance with some embodiments of the disclosure.

[0008] FIGS. 3A-3L show cross-sectional representations of various stages of forming read-only memory (ROM) cell array shown in FIG. 2, in accordance with some embodiments of the disclosure.

[0009] FIGS. 4A-4D show cross-sectional representations of various stages of forming read-only memory (ROM) cell array shown in FIG. 2, in accordance with some embodiments of the disclosure.

DETAILED DESCRIPTION

[0010] The following disclosure provides many different embodiments, or examples, for implementing different fea-

tures of the subject matter provided. Specific examples of components and arrangements are described below to simplify the present disclosure. These are, of course, merely examples and are not intended to be limiting. For example, the formation of a first feature over or on a second feature in the description that follows may include embodiments in which the first and second features are formed in direct contact, and may also include embodiments in which additional features may be formed between the first and second features, such that the first and second features may not be in direct contact. In addition, the present disclosure may repeat reference numerals and/or letters in the various examples. This repetition is for the purpose of simplicity and clarity and does not in itself dictate a relationship between the various embodiments and/or configurations discussed.

[0011] Some variations of the embodiments are described. Throughout the various views and illustrative embodiments, like reference numbers are used to designate like elements. It should be understood that additional operations can be provided before, during, and after the method, and some of the operations described can be replaced or eliminated for other embodiments of the method.

[0012] Embodiments for forming a read-only memory (ROM) cell device structure are provided. FIG. 1 shows a circuit diagram of a read-only memory (ROM) cell array 100, in accordance with some embodiments of the disclosure. The ROM cell array 100 includes a number of rows and a number of columns. The ROM cell array 100 includes four word lines WY-Y+3, WY-Y+2, WY-Y+1 and WY-Y, two bit lines BL-X and BL-X+1, and two ground potentials GND. The ROM cell array 100 is addressed by word lines WY-Y+3, WY-Y+2, WY-Y+1 and WY-Y. Other circuit (e.g. controller) can access ROM cell array 100 through the word lines and bit lines BL-X and BL-X+1.

[0013] The ROM cell array 100 includes a first transistor 12, a second transistor 14, a third transistor 16, a fourth transistor 18, a first isolation transistor 21, a second isolation transistor 23 and a third isolation transistor 25. The gate terminals of the first transistor 12, the second transistor 14, the third transistor 16 and the fourth transistor 18 are biased from the word lines WY-Y+3, WY-Y+2, WY-Y+1 and WY-Y. A reading voltage for activating the first transistor 12, the second transistor 14, the third transistor 16 and the fourth transistor 18 is provided through the word lines WY-Y+3, WY-Y+2, WY-Y+1 and WY-Y. The drain terminal of the first transistor 12 is biased from the bit line BL-X. The source terminal of the first transistor 12 is electrically connected to the ground potential GND.

[0014] The gate terminals of the first isolation transistor 21, the second isolation transistor 23 and the third isolation transistor 25 are electrically connected to the ground potential GND. In a first bit cell, a first group of transistors includes at least two transistors, such as the first transistor 12 and the second transistor 14. In a second bit cell, a second group of transistors includes at least two transistors, such as the third transistor 16 and the fourth transistor 18. The second isolation transistor 23 is formed between the first bit cell and the second bit cell. More specifically, the second isolation transistor 23 is formed between the first group of transistors and the second group of transistors. The first isolation transistor 21, the second isolation transistor 23, and the third isolation transistor 25 are configured to electrically isolate the adjacent transistors which belong to different bit cells.

[0015] In the right side of FIG. 1, the layout of the first column is similar to that of the second column. Another four transistors **32,34,36,38** are formed next to the transistors **12,14,16,18** and two isolation transistors **41, 43, 45** are next to the isolation transistors **23, 25**. The drain terminal of another four transistors **32,34,36,38** are biased from the bit line BL-X+1. The gate terminals of another four transistors **32,34,36,38** are electrically connected to the ground potential GND.

[0016] FIG. 2 shows a layout diagram of a read-only memory (ROM) cell array **100**, in accordance with some embodiments of the disclosure. The ROM cell array **100** includes a first continuous region **10** and a second continuous region **20**. In some other embodiments, the first continuous region **10** has a first-type conductivity (e.g. n-type or p-type), and the second continuous region **20** has the same-type conductivity. In some other embodiments, the first continuous region **10** has a first-type conductivity (e.g. n-type or p-type), and the second continuous region **20** has a second-type conductivity opposite to the first-type conductivity.

[0017] The first continuous region **10** and the second continuous region **20** are formed over a substrate **102** (shown in FIG. 3A). The substrate **102** may be made of silicon or other semiconductor materials. Alternatively or additionally, the substrate **102** may include other elementary semiconductor materials such as germanium. In some embodiments, the substrate **102** is made of a compound semiconductor such as silicon carbide, gallium arsenic, indium arsenide, or indium phosphide. In some embodiments, the substrate **102** is made of an alloy semiconductor such as silicon germanium, silicon germanium carbide, gallium arsenic phosphide, or gallium indium phosphide. In some embodiments, the substrate **102** includes an epitaxial layer. For example, the substrate **102** has an epitaxial layer overlying a bulk semiconductor. The bulk semiconductor may be silicon, germanium, or other suitable materials.

[0018] The first continuous region **10** and the second continuous region **20** can reduce or eliminate the use of isolation structures, such as a shallow trench isolation (STI) region. Therefore, the stress on the substrate may be reduced.

[0019] The first continuous region **10** and a second continuous region **20** are surrounded by an isolation region **30**. In other words, the first continuous region **10** is insulated from the second continuous region **20** by the isolation region **30**. In some embodiments, the isolation region **30** is the shallow trench isolation (STI) region.

[0020] The ROM cell array **100** further includes a number of word lines **204** and a number of isolation lines **206**. The word lines **204** are shown as horizontal lines and labeled as WL-Y, WL-Y+1, WL-Y+2 and WL-Y+3.

[0021] The isolation lines **206** are shown as horizontal lines disposed between adjacent word lines **204**. For example, the isolation lines **206** are disposed between the word lines WL-Y+1 and WL-Y+2, below the word line WL-Y and above the word line WL-Y+3.

[0022] The ROM cell array **100** further includes a number of bit lines **212**, and a number of ground potential (V_{SS}) lines **214**. The bit lines **212** are shown as vertical lines and labeled as BL-X and BL-X+1. The bit lines **212** are orthogonal to the word lines **204**. The V_{SS} lines **214** are shown as vertical lines and are orthogonal to the word lines **204**. In some embodiments, the bit lines **212** are formed in a first metal layer (M_1)

(shown in FIG. 3K) and connected to a second metal layer (M_2) via conductive vias **180**.

[0023] The isolation transistors **21, 23, 25** controlled by the isolation lines **206** remain at all times in the "off" state. In some embodiments, the isolation structure **144a** (shown in FIG. 3K) is the P-type MOS device, and the isolation lines **206** is electrically connected to the voltage supply (Vdd) of the PMOS device. In some embodiments, the isolation structure **144a** (shown in FIG. 3K) is the N-type MOS device, and the isolation lines **206** is electrically connected to the ground potential (GND) of the NMOS device.

[0024] The ROM cell array **100** includes four bit cell regions **52, 54, 56** and **58**. The first bit cell region **52** includes two word lines **204** (also called WL-Y+3 and WL-Y+2), half of the isolation line **206** which is above the word line WL-Y+3, and half of the isolation line **206** which is below the word line WL-Y+2. The second bit cell region **54** includes two word lines **204** (also called WL-Y and WL-Y+1), half of the isolation line **206** which is above the word line WL-Y, and half of the isolation line **206** which is below the word line WL-Y+1. The isolation transistors **21, 23, 25**, which remain at all times in the "off" state, are provided between the transistors in two adjacent bit cell regions to reduce leakage current there-between.

[0025] As shown in FIG. 2, the isolation line **206** is formed between the first group of word lines **204** in the first bit cell region **52** and the second group of word lines **204** in the second bit cell region **54**. The word lines **204** and the isolation line **206** are formed in the same metal layer, such as second metal layer (M_2). The bit lines **212** and V_{SS} lines **214** are formed in the first metal layer (M_1) below the second metal layer (M_2). The bit lines **212** in the first metal layer (M_1) are connected to the word lines **204** in the second metal layer (M_2) through via **116**.

[0026] FIGS. 3A-3K show cross-sectional representations of various stages of forming read-only memory (ROM) cell array **100** shown in FIG. 2, in accordance with some embodiments of the disclosure. FIG. 3A is a cross-sectional representation along the line AA' in FIG. 2.

[0027] As shown in FIG. 3A, an active region **104** is formed over the substrate **102**. The active region **104** is formed from the substrate **102** and may have N-type conductivity or P-type conductivity.

[0028] Instead of using the STI isolation structure, the isolation transistors **21, 23, 25** are configured to provide isolation between adjacent transistors. Accordingly, the active region **104** eliminates the use of an STI isolation structure between two transistor device structures. The active region **104** includes the first bit cell region **52** and the second bit cell region **54**. A number of dummy gate structures **106** are formed over the active region **104**. In some embodiments, the dummy gate structures **106** are made of polysilicon.

[0029] After the dummy gate structures **106** are formed, spacers **108** are formed over the opposite sidewalls of the dummy gate structures **106**, as shown in FIG. 3B in accordance with some embodiments of the disclosure. The spacers **108** may be a single layer or multiple layers. The spacers **108** are formed by deposition processes, such as a chemical vapor deposition (CVD) process, high-density plasma chemical vapor deposition (HDPCVD) process, spin-on process, sputtering process, or another applicable process.

[0030] Afterwards, the source/drain (S/D) structures **110** are formed in the active region **104**. In some embodiments,

the source/drain (S/D) structures **110** are epitaxial structures and they are formed by an epitaxial (epi) process. In some embodiments, the source/drain (S/D) structures **110** include Ge, SiGe, InAs, InGaAs, InSb, GaAs, GaSb, InAlP, InP, or the like.

[0031] After the source/drain (S/D) structures **110** are formed, an inter-layer dielectric (ILD) structure **112** is formed over the dummy gate structures **106** and the active region **104**, as shown in FIG. 3C in accordance with some embodiments of the disclosure.

[0032] The ILD structure **112** may include multilayers made of multiple dielectric materials, such as silicon oxide, silicon nitride, silicon oxynitride, tetraethoxysilane (TEOS), phosphosilicate glass (PSG), borophosphosilicate glass (BPSG), low-k dielectric material, and/or other applicable dielectric materials. Examples of low-k dielectric materials include, but are not limited to, fluorinated silica glass (FSG), carbon doped silicon oxide, amorphous fluorinated carbon, parylene, bis-benzocyclobutenes (BCB), or polyimide.

[0033] The ILD material **112** is formed by a deposition process, such as chemical vapor deposition (CVD), physical vapor deposition, (PVD), atomic layer deposition (ALD), spin-on coating, or another applicable process. Afterwards, a polishing process is performed to the ILD structure **112** until the top surfaces of the dummy gate structures **106** are exposed. In some embodiments, the ILD structure **112** is planarized by a chemical mechanical polishing (CMP) process.

[0034] Afterwards, the dummy gate structures **106** are removed to form a number of trenches **114**, as shown in FIG. 3D in accordance with some embodiments of the disclosure. In some embodiments, the dummy gate structures **106** are removed by a wet etching process or a dry etching process.

[0035] Afterwards, a gate dielectric layer **120** is conformally formed in the trench **114** as shown in FIG. 3E, in accordance with some embodiments. More specifically, the gate dielectric layer **120** is formed over bottom surfaces and sidewalls of the trenches **114**, and over the inter-layer dielectric (ILD) structure **112**.

[0036] The gate dielectric layer **120** may be a single layer or multiple layers. The gate dielectric layer **120** is made of silicon oxide (SiOx), silicon nitride (SixNy), silicon oxynitride (SiON), dielectric material(s) with high dielectric constant (high-k), a combination thereof, or other suitable material. Examples of high-k dielectric materials include hafnium oxide, zirconium oxide, aluminum oxide, hafnium dioxide-alumina alloy, hafnium silicon oxide, hafnium silicon oxynitride, hafnium tantalum oxide, hafnium titanium oxide, hafnium zirconium oxide, the like, or a combination thereof, or other suitable material.

[0037] Afterwards, a first material **122** is conformally formed in the trench **114** and over the gate dielectric layer **120**, as shown in FIG. 3F, in accordance with some embodiments. The first material **122** is configured to adjust the work function value of the gate structure of the transistor device. The thickness of the work function layer affects the threshold voltage (V_{th}) of the transistor. In some embodiments, when a PMOSFET device with a thinner work function layer is used as the isolation structure, the PMOSFET device may exhibit a higher threshold voltage. In other embodiments, when the NMOSFET device with thicker work function layer is used as the isolation structure, the NMOSFET device will have a higher threshold voltage.

[0038] In some embodiments, the first material **122** is made of P-type conductivity materials including titanium nitride (TiN), tantalum nitride (TaN), ruthenium (Ru), molybdenum (Mo), aluminum (Al), tungsten nitride (WN), zirconium disilicide (ZrSi₂), molybdenum disilicide (MoSi₂), tantalum silicide (TaSi₂), nickel silicide (NiSi₂), other suitable p-type work function materials, or a combination thereof, or other suitable material. In some other embodiments, the first material **122** is made of N-type conductivity materials including titanium (Ti), silver (Ag), tantalum aluminum (TaAl), tantalum aluminum carbide (TaAlC), titanium aluminum nitride (TiAlN), tantalum carbide (TaC), tantalum carbide nitride (TaCN), tantalum silicon nitride (TaSiN), manganese (Mn), zirconium (Zr), other suitable n-type work function materials, or a combination thereof, or other suitable material.

[0039] In some embodiments, the first material **122** is formed by a deposition process, such as chemical vapor deposition (CVD), physical vapor deposition, (PVD), atomic layer deposition (ALD), spin-on coating, or another applicable process. In some embodiments, the first material **122** has a first thickness T_1 .

[0040] After the first material **122** is formed, a mask **124** is disposed on the first material **122** and patterned to form a patterned mask **124** covering a portion of the first material **122**, as shown in FIG. 3G, in accordance with some embodiments. The mask **124** is configured to protect the underlying layers from being removed by the subsequent processes. Afterwards, a portion of the first material **122** is selectively removed to expose the trenches **125**. In some embodiments, the portion of the first material **122** is removed by a dry etching process or a wet etching process.

[0041] Afterwards, the mask **124** is removed, and a second material **126** is formed over the first material **122** and in the trenches **125**, as shown in FIG. 3H, in accordance with some embodiments. The first material **122** is different from the second material **126**. The second material **126** is also configured to adjust the work function value of the gate structure of the transistor device.

[0042] In some embodiments, the second material **126** is made of P-type conductivity materials including titanium nitride (TiN), tantalum nitride (TaN), ruthenium (Ru), molybdenum (Mo), aluminum (Al), tungsten nitride (WN), zirconium disilicide (ZrSi₂), molybdenum disilicide (MoSi₂), tantalum silicide (TaSi₂), nickel silicide (NiSi₂), other suitable p-type work function materials, or a combination thereof, or other suitable material. In some other embodiments, the second material **126** is made of N-type conductivity materials including titanium (Ti), silver (Ag), tantalum aluminum (TaAl), tantalum aluminum carbide (TaAlC), titanium aluminum nitride (TiAlN), tantalum carbide (TaC), tantalum carbide nitride (TaCN), tantalum silicon nitride (TaSiN), manganese (Mn), zirconium (Zr), other suitable n-type work function materials, or a combination thereof, or other suitable material. In some embodiments, the second material **126** has a second thickness T_2 .

[0043] After the second material **126** is formed, a metal gate electrode layer **128** is formed over the second material **126**, as shown in FIG. 3I, in accordance with some embodiments.

[0044] In some embodiments, the metal gate electrode layer **128** is made of conductive material, such as aluminum (Al), copper (Cu), tungsten (W), titanium (Ti), tantalum (Ta), or another applicable material. The metal gate elec-

trode layer 128 is formed by a deposition process, such as chemical vapor deposition (CVD), physical vapor deposition (PVD), atomic layer deposition (ALD), high density plasma CVD (HDPCVD), metal organic CVD (MOCVD), or plasma enhanced CVD (PECVD).

[0045] Afterwards, the excess metal gate electrode materials are removed by a polishing process, as shown in FIG. 3J, in accordance with some embodiments. As a result, the top surface of the metal gate electrode layer 128 and the top surface of the ILD structure 112 are exposed. In other words, the top surface of the metal gate electrode layer 128 is planar with the top surface of the ILD structure 112. In some embodiments, the polishing process is a chemical mechanical polishing (CMP) process.

[0046] As shown in FIG. 3J, a first gate structure 142a and a second gate structure 142b are formed in the first bit cell region 52, and the third gate structure 142c and the fourth gate structure 142d are formed in the second bit cell region 54. A first isolation structure 144a is adjacent to the first gate structure 142a. A second isolation structure 144b is formed between the second gate structure 142b and the third gate structure 142c. A third isolation structure 144c is formed adjacent to the fourth gate structure 142d.

[0047] The first group of gate structures including at least two gate structures 142a, 142b is formed in the first bit cell region 52, and the second group of gate structures including at least two gate structures 142c, 142d is formed in the second bit cell region 54. The isolation structure 144b is formed between the first group of gate structures and the second group of gate structures.

[0048] It should be noted that the gate structures 142a, 142b, 142c and 142d are functional or operational gate structures, but the isolation structures 144a, 144b and 144c are dummy structures which do not perform any function. As mentioned above, the isolation structures 144a, 144b, and 144c controlled by the isolation lines 206 (shown in FIG. 2) remain at all times in the "off" state. The isolation structures 144a, 144b and 144c are electrically connected to the isolation lines 206, and remain at all times in the "off" state.

[0049] Half of the second isolation structure 144b belongs to the first bit cell region 52, and half of the second isolation structure 144b belongs to the second bit cell region 54. In other words, the second isolation structure 144b is at the boundary between the first bit cell region 52 and the second bit cell region 54.

[0050] The first gate structure 142a includes the gate dielectric layer 120, the first work function layer made of the second material 126 and the metal gate electrode layer 128. The first isolation structure 144a includes the gate dielectric layer 120, the second work function layer made of the first material 122 and the second material 126, and the metal gate electrode layer 128. Therefore, the first work function layer of the first gate structure 142a has a thickness T_2 , and the second work function layer of the first isolation structure 144a has a sum thickness T_3 of the first thickness T_1 and the second thickness T_2 . The sum thickness T_3 is larger than the thickness T_2 .

[0051] In some embodiments, the first work function layer of the first gate structure 142a is made of the second material 126, and therefore the first gate structure 142a has a first-type conductivity. The second work function layer of the first isolation structure 144a is made of the first material 122 and the second material 126, and therefore the first isolation structure 144a has a second-type conductivity opposite to

the first-type conductivity. In some embodiments, the first work function layer of the first gate structure 142a is N-type transistor, and the second work function layer of the first isolation structure 144a is P-type transistor.

[0052] It should be noted that the threshold voltage (V_{th}) difference between the first isolation structure 144a and the first gate structure 142a is caused by the thickness difference ($\Delta T = T_3 - T_2$) between the work function layer of the first isolation structure 144a and the work function layer of the first gate structure 142a. The advantage of the threshold voltage (V_{th}) difference is that the leakage current between two gate structures in adjacent bit cell regions may be reduced. In other words, the work function value of the gate structure is affected by changing the thickness of the work function layer. The threshold voltage (V_{th}) is affected by the work function value. Therefore, the threshold voltage (V_{th}) is affected by changing the thickness of the work function layer of the gate structure. In addition, the leakage current is reduced when the transistor has a higher threshold voltage (V_{th}). Accordingly, when the isolation structure 114a has a higher threshold voltage (V_{th}) than the adjacent first gate structure 142a, the leakage current is reduced by the isolation structure 114a. Therefore, the performance of the gate structure is improved when the leakage current is reduced.

[0053] In some embodiments, the thickness difference ($\Delta T = T_3 - T_2$) is in a range from about 1 nm to 3 nm. If the thickness difference ΔT is smaller than 1 nm, the leakage current suppression effect is not good enough. If the thickness difference ΔT is greater than 3 nm, the metal gate electrode layer 128 is hardly to filled into the trench which is used to form the gate structure.

[0054] In some embodiments, the threshold voltage (V_{th}) difference is in a range from about 100 mV to about 500 mV. If the threshold voltage (V_{th}) difference is smaller than 100 mV, the leakage current suppression effect is not good enough. If the threshold voltage (V_{th}) difference is greater than 500 mV, the performance of the gate structures may suffer.

[0055] After the polishing process, an interconnect structure 160 is formed over the gate structures 142a, 142b, 142c and 142d, and the isolation structures 144a, 144b and 144c, as shown in FIG. 3K, in accordance with some embodiments. A dielectric layer 152 is formed over the gate structures 142a, 142b, 142c and 142d, and the isolation structures 144a, 144b, 144c. The contact structures 150a, 150b, 150c, 150d, 150e, 150f are formed through the dielectric layer 152 and the ILD structure 112. The vias 162 are formed over the top surfaces of the gate structures 142a, 142b, 142c and 142d, and the top surfaces of the isolation structures 144a, 144b, 144c.

[0056] The contact structures 150a, 150b, 150c, 150d, 150e, 150f are electrically connected to the S/D structure 110 in the active region 104. The top surface of the contact structures 150a, 150b, 150c, 150d, 150e, 150f are higher than the top surface of the gate structures 142a, 142b, 142c and 142d.

[0057] The first contact structure 150a, the second contact structure 150b and the third contact structure 150c are formed in the first bit cell region 52, and the second contact structure 150b is formed between the first contact structure 150a and the third contact structure 150c. The fourth contact structure 150d, the fifth contact structure 150e and the sixth contact structure 150f are formed in the second bit cell

region **54**, and the fifth contact structure **150e** is formed between the fourth contact structure **150d** and the sixth contact structure **150f**.

[0058] The first contact structure **150a** is formed between the first isolation structure **144a** and the first gate structure **142a**. In some embodiments, the first contact structure **150a** is electrically connected to the bit lines **212** (shown in FIG. 2). The third contact structure **150c** is formed between the second gate structure **142b** and the second isolation structure **144b**. In some embodiments, the third contact structure **150c** is electrically connected to the bit lines **212** (shown in FIG. 2).

[0059] The second contact structure **150b** is formed between the first gate structure **142a** and the second gate structure **142b**. In some embodiments, the second contact structure **150b** is electrically connected to the ground potential (Vss). The second contact structure **150b** is configured to isolate the first gate structure **142a** and the second gate structure **142b**.

[0060] The fourth contact structure **150d** is electrically connected to the bit lines **212** (shown in FIG. 2). The fifth contact structure **150e** is electrically connected to the ground potential (Vss). The sixth contact structure **150f** is electrically connected to the bit lines **212** (shown in FIG. 2).

[0061] Afterwards, the first metal layer **164**, the second metal layer **166** and the vias **162** are formed over the contact structure **150a**, **150b**, **150c**, **150d**, **150e**, **150f** and over the gate structures **142a**, **142b**, **142c** and **142d**, and the isolation structures **144a**, **144b**, **144c**, as shown in FIG. 3L, in accordance with some embodiments.

[0062] The interconnect structure **160** includes the first metal layer **164**, the second metal layer **166** and vias **162** formed in a dielectric layer **170**. In some embodiments, the first metal layer **164**, the second metal layer **166** and vias **162** are made of conductive materials, such as copper (Cu), copper alloy, aluminum (Al), aluminum alloys or a combination thereof, or other suitable material. In some embodiments, the first metal layer **164**, the second metal layer **166** and vias **162** are copper (Cu) or copper alloy. In some embodiments, the interconnect structure **160** is formed in a back-end-of-line (BEOL) process. In some embodiments, the first metal layer **164**, the second metal layer **166** and vias **162** are formed by single and/or dual damascene processes. The metal layers **164**, **166** include multiple metal layers (namely M_1 , M_2 , M_3 , . . . , and M_{top}) which are interconnected through vias **162**.

[0063] It should be noted that in some embodiments, the bit lines **212** and the Vss lines **214** (shown in FIG. 2) are formed in the first metal layer (M_1) **164**. The word lines **204** and the isolation lines **206** are formed in the second metal layer (M_2) **166**.

[0064] The metal routings of the conductive features as shown in FIG. 3L, are merely examples. Alternatively, other designs of metal routings of conductive features may be used according to actual application.

[0065] FIGS. 4A-4D show cross-sectional representations of various stages of forming the read-only memory (ROM) cell array **100** shown in FIG. 2, in accordance with alternative embodiments in accordance with the instant disclosure. FIG. 4A is a cross-sectional representation along the line AA' in FIG. 2. Processes and materials used to form the ROM device structure in FIGS. 3A-3L may be similar to, or the same as, those used to form the ROM device structure in FIGS. 4A-4D and are not repeated herein.

[0066] As shown in FIG. 4A, the mask layer **124** is formed over a portion of the first material **122**. Afterwards, a portion of the first material **122** which is not protected by the mask layer **124** is removed by an etching process.

[0067] Afterwards, the mask layer **124** is removed, and the second material **126** is formed over the first material **122** and the gate dielectric layer **120**, as shown in FIG. 4B, in accordance with some embodiments.

[0068] After the second material **126** is formed, the metal gate electrode layer **128** is formed over the second material **126**, as shown in FIG. 4C, in accordance with some embodiments.

[0069] Afterwards, the first gate structure **142a** and the second gate structure **142b** are formed in the first bit cell region **52**, and the third gate structure **142c** and the fourth gate structure **142d** are formed in the second bit cell region **54**, as shown in FIG. 4D, in accordance with some embodiments. The first isolation structure **144a** is adjacent to the first gate structure **142a**. The second isolation structure **144b** is formed between the second gate structure **142b** and the third gate structure **142c**.

[0070] It should be noted that the first work function layer of the first gate structure **142a** has a sum thickness T_3 which is the sum of the first thickness T_1 and the second thickness T_2 . The second work function layer of the first isolation structure **144a** has a thickness T_2 . The ROM device structure has leakage current suppression function by forming the thickness difference between the gate structure and the isolation structure.

[0071] Embodiments for a read-only memory (ROM) device structure and method for formation the same are provided. The ROM device structure includes an isolation structure between two groups of gate structures. The isolation structure is configured to isolate a first group of gate structures and a second group of gate structures. A threshold voltage (V_{th}) difference between the gate structure and the isolation structure is caused by forming the thickness difference between a thickness of a work function layer of the gate structure and that of a work function layer of the isolation structure. The isolation structure with a higher threshold voltage (V_{th}) has a relatively lower leakage current. Accordingly, the leakage current is suppressed by adjusting the thickness difference of the gate structure and the isolation structure, and therefore the performance of the ROM device structure is improved.

[0072] In some embodiments, a read-only memory (ROM) device structure is provided. The ROM device structure includes an active region over a substrate, and the active region includes a first bit-cell region and a second bit cell region. The ROM device structure includes a first gate structure formed over the active region in the first bit-cell region, and the first transistor comprises a first work function layer with a first thickness. The ROM device structure includes a second gate structure formed over the active region in the second bit-cell region, and the first transistor comprises a first work function layer with the first thickness. The ROM device structure includes an isolation structure formed over the active region and the isolation gate structure is between the first gate structure and the second gate structure. The isolation structure includes a second work function layer with a second thickness, and the second thickness is larger than or smaller than the first thickness. The ROM device structure further includes a first contact structure formed over the active region in the first bit-cell

region, and the first contact structure is between the first gate structure and the isolation structure. The ROM device structure includes a second contact structure formed over the active region in the second bit-cell region, and the second contact structure is between the second gate structure and the isolation structure.

[0073] In some embodiments, a read-only memory (ROM) device structure is provided. The ROM device structure includes an active region over a substrate and a first gate structure formed on the active region. The first gate structure includes a first work function layer with a first-type conductivity. The ROM device structure includes a second gate structure formed on the active region, and the second gate structure includes a first work function layer with the a first-type conductivity. The ROM device structure includes a first contact structure formed over the active region, and the first contact structure is between the first gate structure and the second gate structure. The ROM device structure includes a first isolation structure formed over the active region, and the first isolation structure is adjacent to the first gate structure. The first isolation structure includes a second work function layer with a second-type conductivity, and the first-type conductivity is different from the second-type conductivity. The ROM device structure further includes a second isolation structure formed over the active region, and the second isolation structure is adjacent to the second gate structure.

[0074] In some embodiments, a read-only memory (ROM) device structure is provided. The ROM device structure includes an active region formed over a substrate and a first group of word lines formed over the active region. The first group of word lines comprises at least two word lines. The ROM device structure includes a second group of word lines formed on the active region, and the second group of word lines comprises at least two word lines. The ROM device structure further includes an isolation line between the first group of word lines and the second group of word lines and over the active region. The first group of word lines, the second group of word lines, and the isolation line are formed in a second metal layer.

[0075] The foregoing outlines features of several embodiments so that those skilled in the art may better understand the aspects of the present disclosure. Those skilled in the art should appreciate that they may readily use the present disclosure as a basis for designing or modifying other processes and structures for carrying out the same purposes and/or achieving the same advantages of the embodiments introduced herein. Those skilled in the art should also realize that such equivalent constructions do not depart from the spirit and scope of the present disclosure, and that they may make various changes, substitutions, and alterations herein without departing from the spirit and scope of the present disclosure.

1. A read-only memory (ROM) device structure, comprising:

- an active region over a substrate, wherein the active region comprises a first bit-cell region and a second bit cell region;
- a first gate structure formed over the active region in the first bit-cell region, wherein the first gate structure comprises a first work function layer with a first thickness;

- a second gate structure formed over the active region in the second bit-cell region, wherein the second gate structure comprises the first work function layer with the first thickness;

- an isolation structure formed over the active region, wherein the isolation structure is between the first gate structure and the second gate structure, wherein the isolation structure comprises a second work function layer with a second thickness, and the second thickness is larger than or smaller than the first thickness;

- a first contact structure formed over the active region in the first bit-cell region, wherein the first contact structure is between the first gate structure and the isolation structure.

2. The read-only memory (ROM) device structure as claimed in claim 1, further comprising:

- an interconnect structure formed over the first gate structure, the second gate structure and the isolation structure, wherein the interconnect structure comprises:

- a first metal layer formed over the first gate structure, wherein the first contact structure is electrically connected to the first metal layer; and

- a second metal layer formed over the first metal layer, wherein the first gate structure is electrically connected to the second metal layer.

3. The read-only memory (ROM) device structure as claimed in claim 1, wherein the first work function layer has a first-type conductivity, and the second work function layer has a second-type conductivity.

4. The read-only memory (ROM) device structure as claimed in claim 1, wherein the active region is a continuous active region which is extending under the first gate structure, the second gate structure and the isolation structure.

5. The read-only memory (ROM) device structure as claimed in claim 1, further comprising:

- a second contact structure formed over the active region in the second bit-cell region, wherein the second contact structure is between the second gate structure and the isolation structure.

6. The read-only memory (ROM) device structure as claimed in claim 1, wherein the isolation structure is electrically connected to a ground potential (GND) or a voltage supply (Vdd).

7. The read-only memory (ROM) device structure as claimed in claim 1, wherein the first contact structure is electrically connected to a voltage supply (Vdd).

8. The read-only memory (ROM) device structure as claimed in claim 1, wherein a top surface of the first contact structure is higher than a top surface of the first gate structure.

9. The read-only memory (ROM) device structure as claimed in claim 1, further comprising:

- a third contact structure formed over the active region, wherein the first gate structure is formed between the first contact structure and the third contact structure, the third contact structure is electrically connected to a ground potential (GND).

10. The read-only memory (ROM) device structure as claimed in claim 1, further comprising:

- a source/drain (S/D) structure formed in the active region and directly below the first contact structure, wherein the S/D structure is between the first gate structure and the second gate structure.

11. A read-only memory (ROM) device structure, comprising:

- an active region over a substrate;
- a first gate structure formed on the active region, wherein the first gate structure comprises a first work function layer with a first-type conductivity;
- a second gate structure formed on the active region, wherein the second gate structure comprises the first work function layer with the first-type conductivity;
- a first contact structure formed over the active region, wherein the first contact structure is between the first gate structure and the second gate structure;
- a first isolation structure formed over the active region, wherein the first isolation structure is closer to the first gate structure than the second gate structure, and the first isolation structure comprises a second work function layer with a second-type conductivity, wherein the first-type conductivity is different from the second-type conductivity; and
- a second isolation structure formed over the active region, wherein the second isolation structure is closer to the second gate structure than the first gate structure.

12. The read-only memory (ROM) device structure as claimed in claim **11**, wherein the first contact structure is electrically connected to a ground potential (GND).

13. The read-only memory (ROM) device structure as claimed in claim **11**, further comprising:

- a second contact structure formed over the active region, wherein the second contact structure is between the first isolation structure and the first gate structure.

14. The read-only memory (ROM) device structure as claimed in claim **13**, wherein the second contact structure is electrically connected to a voltage supply (Vdd).

15. The read-only memory (ROM) device structure as claimed in claim **11**, wherein the first isolation structure is electrically connected to a ground potential (GND) or a voltage supply (Vdd).

16. The read-only memory (ROM) device structure as claimed in claim **11**, wherein a half portion of the first

isolation structure, the first gate structure, the second gate structure and a half portion of the second isolation structure are in a bit-cell region.

17. The read-only memory (ROM) device structure as claimed in claim **11**, wherein the first work function layer has a first thickness, the second work function layer has a second thickness, the first thickness is larger than or smaller than the second thickness.

18. A read-only memory (ROM) device structure, comprising:

- an active region formed over a substrate;
- a first group of word lines formed over the active region, wherein the first group of word lines comprises at least two word lines;
- a second group of word lines formed on the active region, wherein the second group of word lines comprises at least two word lines;
- an isolation line between the first group of word lines and the second group of word lines and over the active region, wherein the first group of word lines, the second group of word lines, and the isolation line are formed in a second metal layer;
- at least two gate structures formed below the first group of word lines, wherein each of the gate structures has a first work function layer with a first thickness; and
- an isolation structure formed below the isolation line, wherein the isolation structure has a second work function layer with a second thickness, and the second thickness is larger than or smaller than the first thickness.

19. (canceled)

20. The read-only memory (ROM) device structure as claimed in claim **18**, further comprising:

- at least two bit lines formed over the active region, wherein the bit lines are orthogonal to the word lines, and the bit lines are formed in a first metal layer below the second metal layer.

* * * * *