



US 20190353342A1

(19) **United States**

(12) **Patent Application Publication**
FINCH et al.

(10) **Pub. No.: US 2019/0353342 A1**

(43) **Pub. Date: Nov. 21, 2019**

(54) **APPARATUS FOR ILLUMINATING
OUTDOOR BAG TOSS GAME**

Publication Classification

(71) Applicant: **Brightz, Ltd.**, Ottawa Lake, MI (US)

- (51) **Int. Cl.**
- F21V 33/00* (2006.01)
- F21S 9/02* (2006.01)
- F21V 21/088* (2006.01)
- F21V 23/04* (2006.01)
- A63B 67/06* (2006.01)
- F21S 4/22* (2006.01)
- F21V 23/00* (2006.01)

(72) Inventors: **Ronald FINCH**, Ottawa Lake, MI (US); **Michael SAUPPE**, Ottawa Lake, MI (US)

(73) Assignee: **Brightz, Ltd.**, Ottawa Lake, MI (US)

- (52) **U.S. Cl.**
- CPC *F21V 33/008* (2013.01); *F21S 9/02* (2013.01); *F21V 21/088* (2013.01); *F21V 2103/37* (2016.08); *A63B 67/06* (2013.01); *F21S 4/22* (2016.01); *F21V 23/001* (2013.01); *F21V 23/04* (2013.01)

(21) Appl. No.: **16/529,009**

(22) Filed: **Aug. 1, 2019**

Related U.S. Application Data

(63) Continuation of application No. 15/351,183, filed on Nov. 14, 2016, now Pat. No. 10,401,020.

(60) Provisional application No. 62/318,539, filed on Apr. 5, 2016, provisional application No. 62/255,100, filed on Nov. 13, 2015.

(57) **ABSTRACT**

Presently disclosed is an illuminated cornhole platform comprising a top portion, at least two side portions, a front portion, a hole portion, at least one leg portion, and a back portion. The cornhole platform is illuminated by an inner illuminating string and an outer illuminating string, one abutting the hole portion and the other wrapped around the outer perimeter for the cornhole platform.

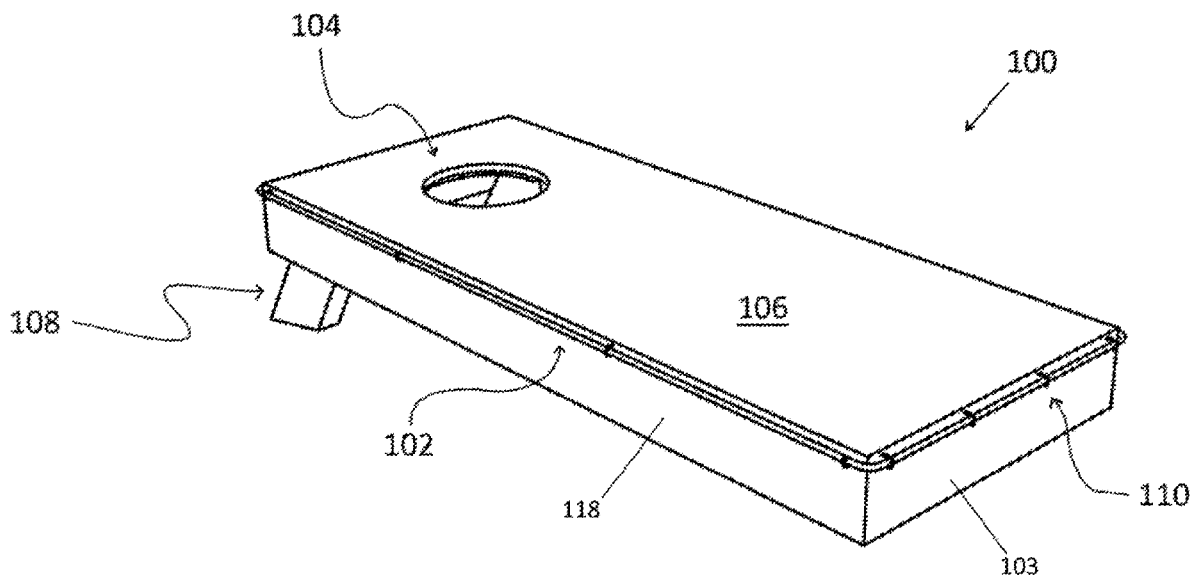

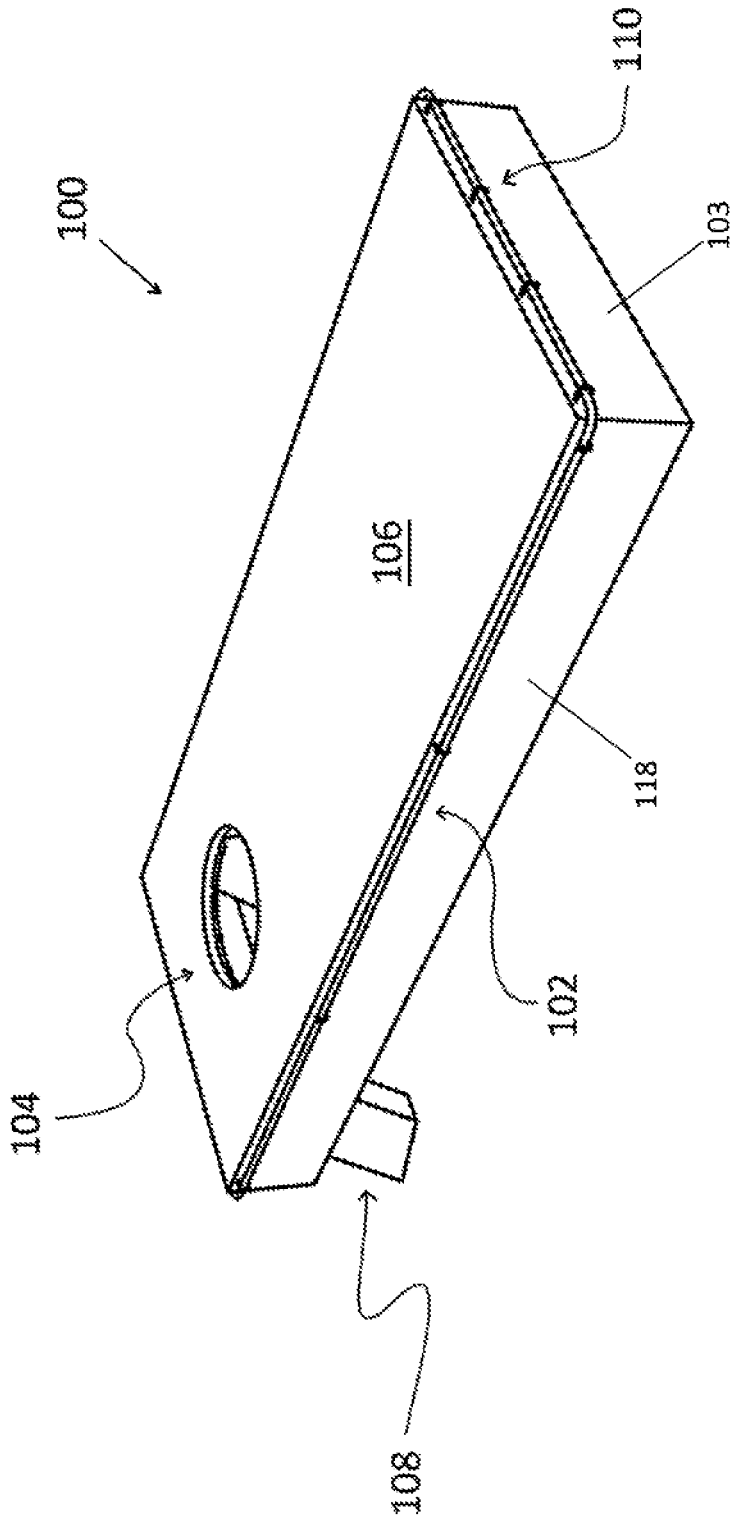

Fig. 1

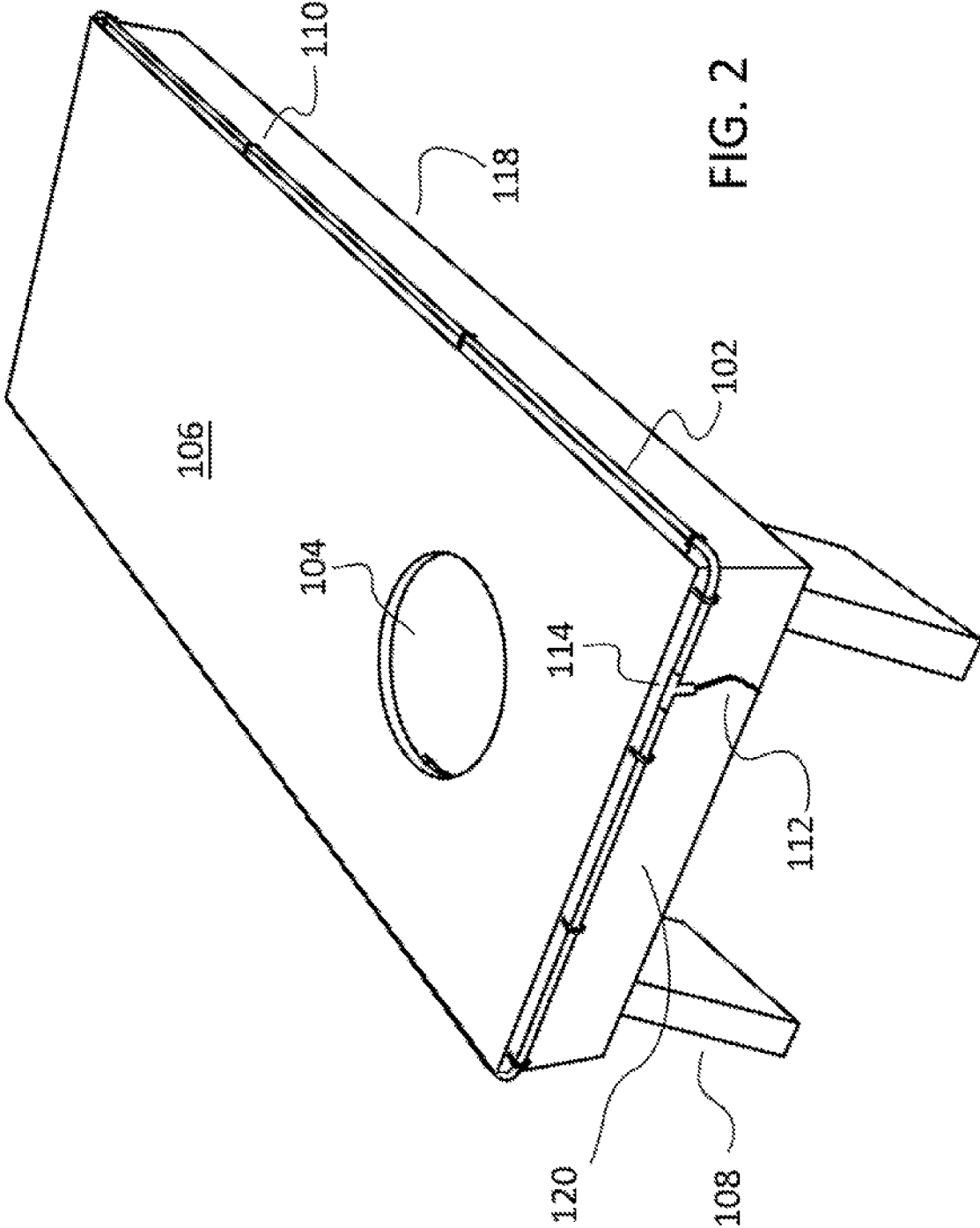

FIG. 2

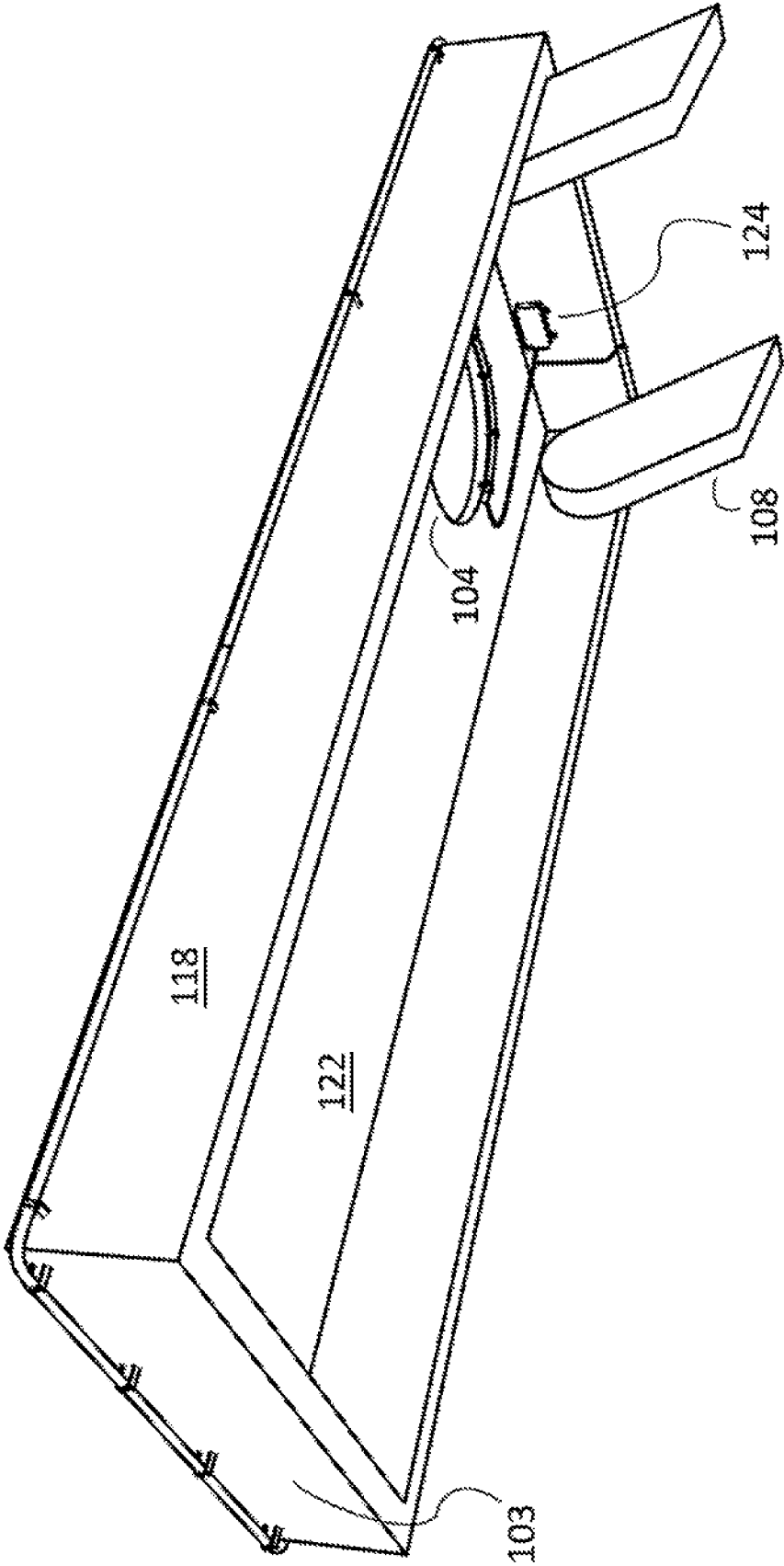

FIG. 3

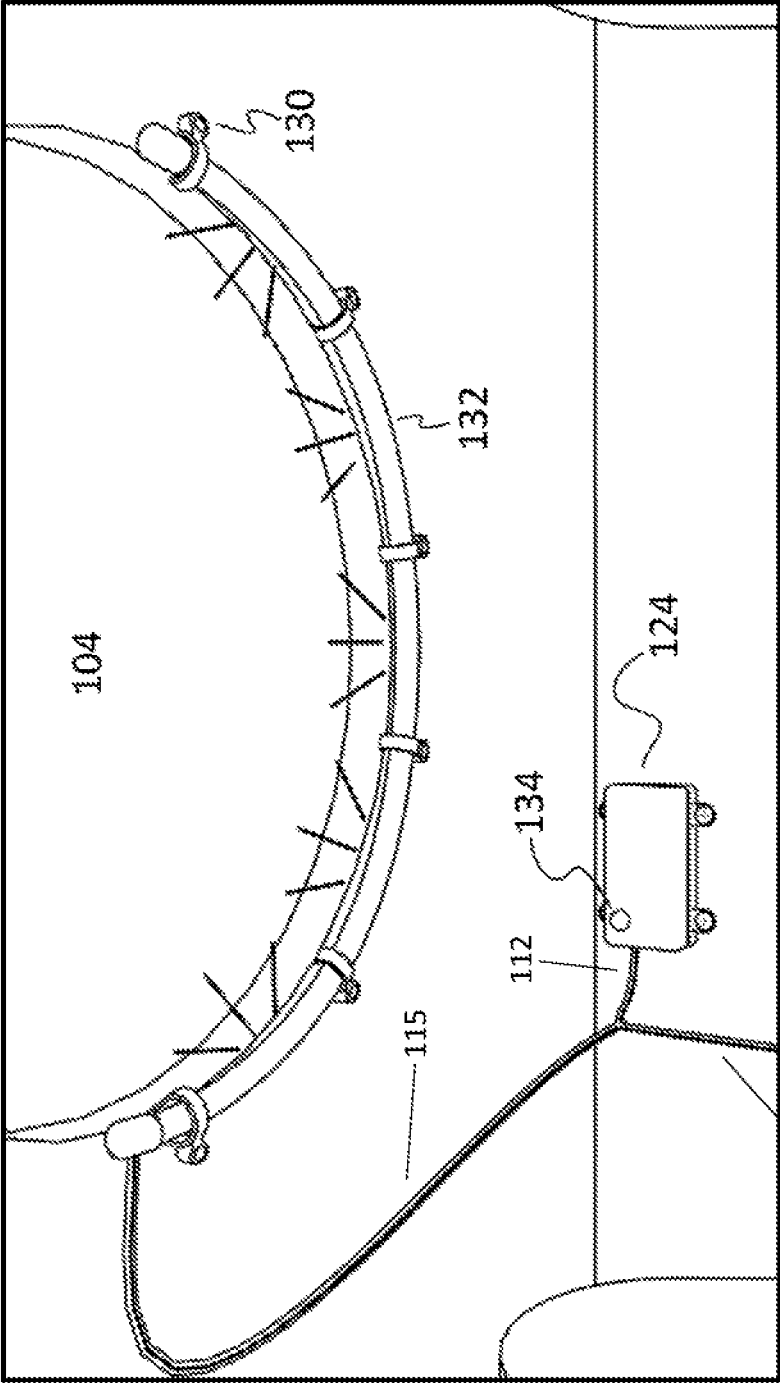

FIG. 4

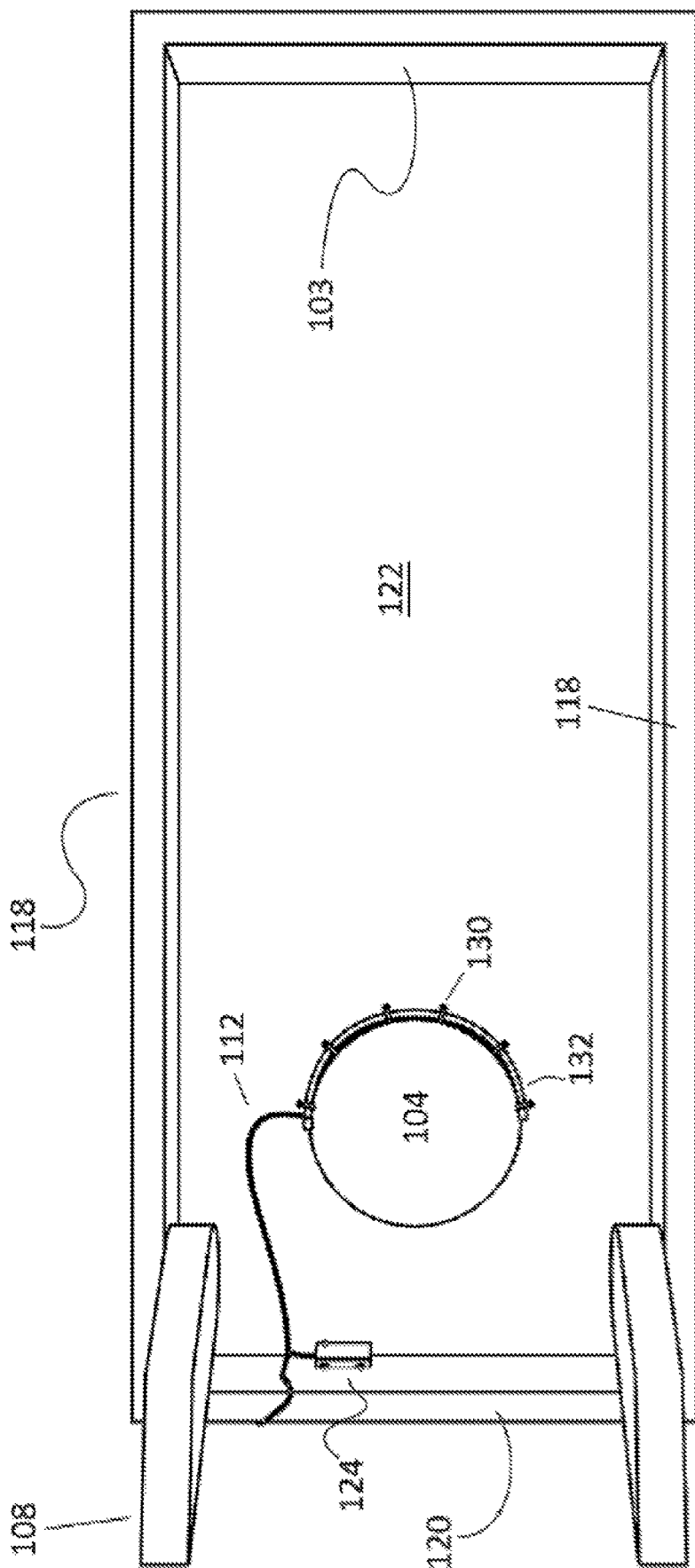

FIG. 5

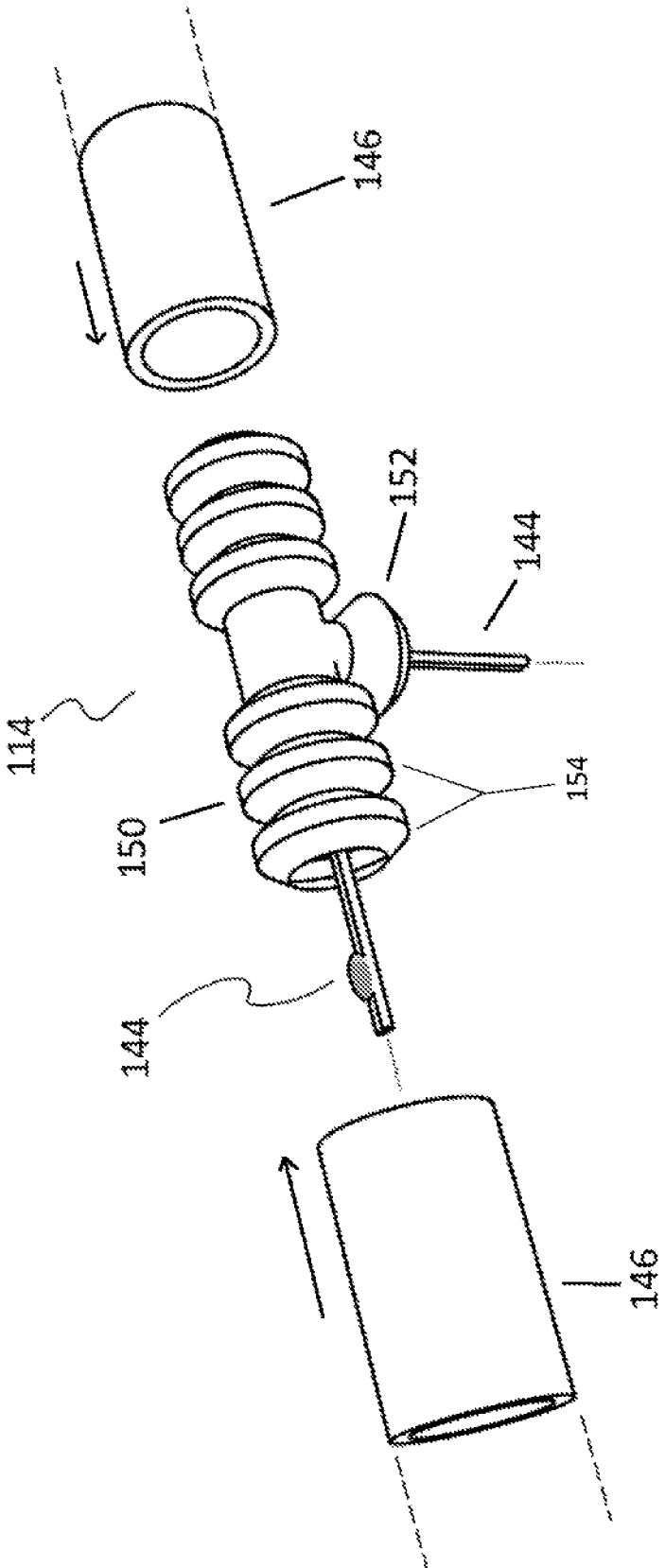

FIG. 7

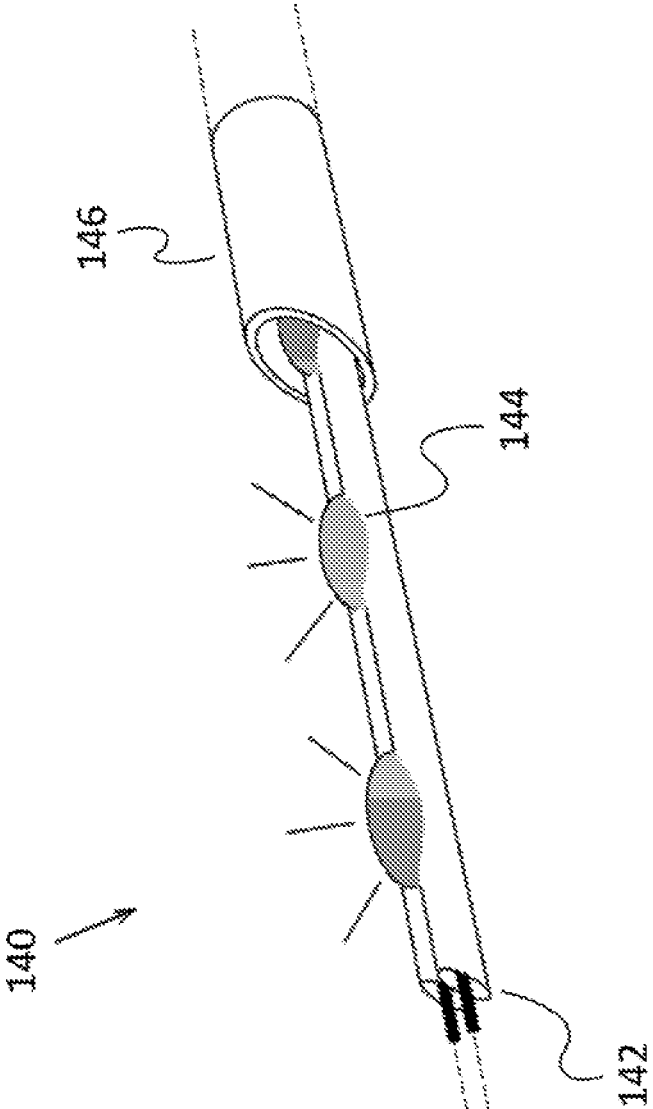

Fig. 6

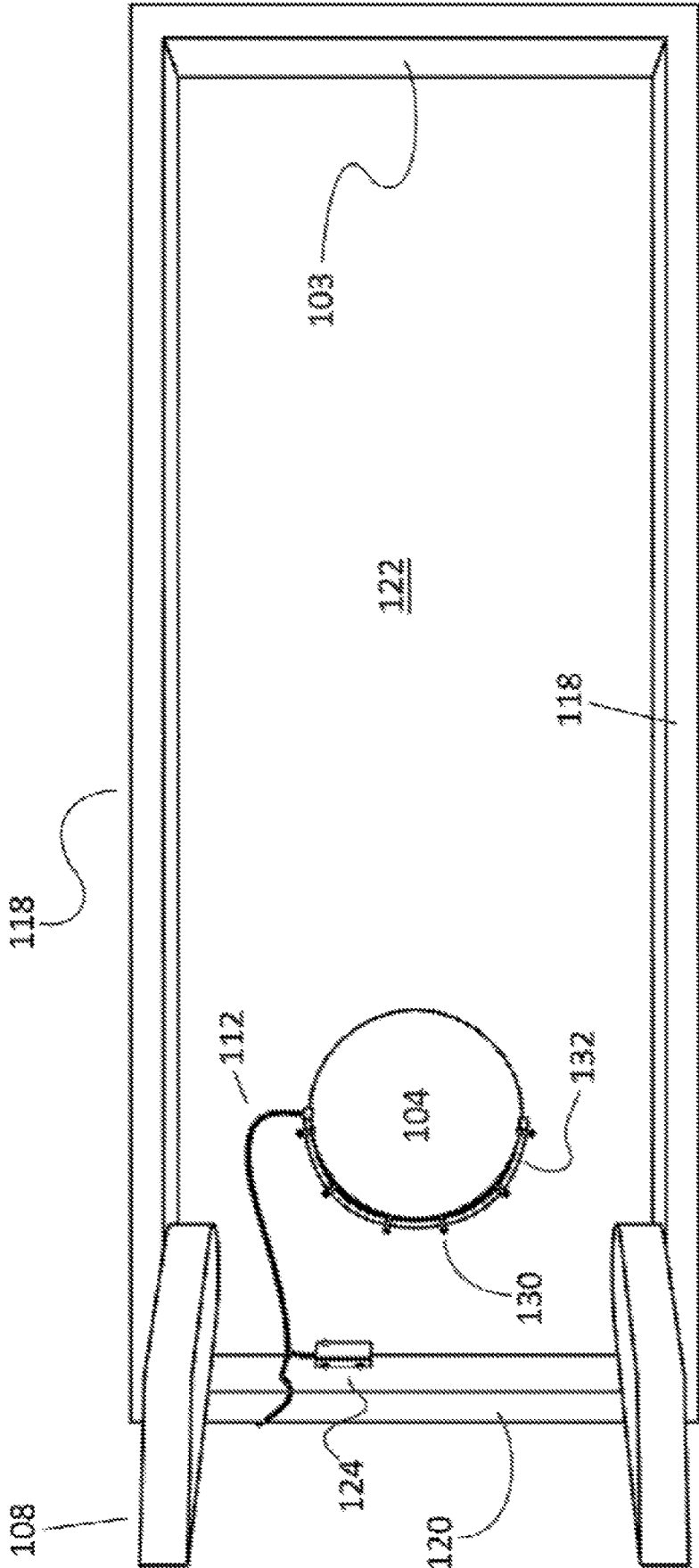

FIG. 8

APPARATUS FOR ILLUMINATING OUTDOOR BAG TOSS GAME

[0001] This non-provisional patent application is a continuation of and claims priority to and benefit of U.S. patent application Ser. No. 15/351,183, filed on Nov. 14, 2016, which claims priority to and benefit of U.S. Provisional Patent Application No. 62/255,100, filed on Nov. 13, 2015, and U.S. Patent Application No. 62/318,539, filed on Apr. 5, 2016, all of which are incorporated herein by reference.

BACKGROUND

[0002] This invention relates to an illuminated bag toss platform, or more generally an illuminated “cornhole” platform.

[0003] There are a number of bag toss games that are played under conditions of low ambient light, such as “cornhole” or “corn toss.” In the game, players take turns pitching small bags at an inclined platform having a hole with a diameter that is designed for the bags to fit through, centered on the platform but with a vertical disposition towards the far end of the platform. The platforms are generally rectangular and consist of a platform surface generally made of rigid material, and foldable risers that elevate and support the vertically inclined end of the platform.

[0004] Being mostly an outdoor game, cornhole is generally played during daylight hours when the players are able to distinguish distance relatively easily and see their target, the platform, and more specifically the hole. However, since it is an excellent outdoor party game, it is often played during the evening where the lighting may not be optimal. Providing sufficient lighting for evening play is inconvenient and sometimes undesirable, since other lighting apparatuses may detract from the ambiance desired at an outdoor party. Thus, there is still a need for a kit to illuminate the platform with sufficient lighting to enable outdoor play in low-light conditions.

SUMMARY

[0005] Accordingly, the present disclosure enables bag toss games to be played under conditions of low ambient light by providing an illuminated cornhole platform. While there are many embodiments of the present invention, in one embodiment the platform contains a power supply which can be attached on an underside of the platform, the power supply powering two wires of Light Emitting Diodes (LEDs). The first wire of LEDs may be placed under the platform on the lower half of the hole in the center of the platform. The second wire of LEDs may be wrapped around the exterior of the platform, attached to side walls forming structural support for the top of the platform. The first wire of LEDs and the second wire of LEDs may be attached to the cornhole platform by way of a fastener. Alternatively, or in addition, the first wire of LEDs and the second wire of LEDs may be attached by way of adhesive, mounting bracket, or any other suitable method.

[0006] Because lights on the cornhole platform may be distracting to the players or may affect the players’ vision of the platform surface or hole, in some embodiments the first wire of LEDs and the second wire of LEDs may be installed on the underside of the platform creating lighting underneath and around the perimeter of the cornhole platform. In other embodiments, a LED wire may be placed only on the lower

half of the hole, in order to prevent players from directly staring at the plurality of light sources while playing.

[0007] The LED wire or wires may be of any suitable single color or multiple color combination. The power supply may be capable of changing the color emitted by the LED wires, or the LED wires may be of a fixed color.

[0008] In some embodiments, the LED wire may comprise a flexible water resistant sheath which may encapsulated the LEDs and electrical wires connected to the power supply.

BRIEF DESCRIPTION OF THE FIGURES

[0009] FIG. 1 illustrates a front-end perspective view of an illuminated cornhole platform;

[0010] FIG. 2 illustrates a back-end perspective view of an illuminated cornhole platform;

[0011] FIG. 3 illustrates a bottom perspective view of an illuminated cornhole platform;

[0012] FIG. 4 illustrates a close-up bottom view of a hole in the illuminated cornhole platform;

[0013] FIG. 5 illustrates a bottom view of the illuminated cornhole platform;

[0014] FIG. 6 illustrates a cutaway view of a segment of an illumination tube of the illuminated cornhole platform; and

[0015] FIG. 7 illustrates a close up exploded view of a tee adapter used on a portion of the illuminated cornhole platform.

[0016] FIG. 8 illustrates a bottom view of the illuminated cornhole platform;

DETAILED DESCRIPTION OF THE FIGURES

[0017] FIG. 1 illustrates a perspective view of an illuminated cornhole platform 100. Typically, the illuminated cornhole platform 100 is rectangular. A top portion 106 forms the upper part of the platform and contains a hole portion 104. Below the top portion is a front portion 103, at least two side portions 118, and a back portion 120 (see FIG. 2). A leg portion 108 is attached to the side portion 118. The leg portion 108 functions to lift the whole apparatus at an angle relative to the ground. Typically, a platform will have two leg portions but may have any number of leg portions, such as one or four.

[0018] The side portions 118, front portion 103, and back portion 120 form an outer perimeter of the illuminated cornhole platform 100. Along a substantial length of that perimeter is an outer illumination string 102 held in place by a plurality of cable clips 110. The outer illumination string 102 contains a plurality of light emitting sources, as is shown in more detail in FIG. 7. The outer illumination string 102 contains a first conductive wire and emits light which enables a person playing a game of cornhole to see an outline of the rectangular platform with minimal if any ambient illumination (i.e., at night).

[0019] FIG. 2 illustrates a back perspective view of the illuminated cornhole platform 100. The top portion 106 contains a hole portion 104 located off-center and designed to accept a tossed bag (e.g., “bean-bag”). The outer illuminating string 102 is placed along the outer perimeter formed by the side portion 118, back portion 120, and front portion 110 (see FIG. 1). The outer illuminating string 102 has a first end and a second end, both of which attach to the tee adapter

114. A first chord **112** extends through the tee adapter and into the outer illuminating string **102**, as is discussed in more detail in FIG. 7.

[0020] FIG. 3 illustrates a bottom perspective view of the rectangular platform **100**. The side portions **118**, back portion **120**, front portion **103**, and a bottom portion **122** form an interior cavity. The leg portions **108** may be placed within that cavity. A power supply **124** may also be affixed to the back portion **120** within that cavity, in order to place the power supply close to the hole portion **104**. The power supply **124** may also be affixed against the bottom portion **122** or in any other suitable location or any other structure of the platform.

[0021] FIG. 4 illustrates a close up bottom view of the hole portion **104** and surrounding environment of the illuminated cornhole platform in the “on” state. The power supply **124** may be attached to the bottom portion **122** or back portion **120** by way of adhesive, threaded fastener, or other means. The power supply **124** contains a switch **134** that can interrupt the flow of electrical current. Extending out from the power supply is a leading wire **112** which splits into a first cord **115** and a second cord **117**. The first cord connects to the outer illuminating string. The second cord connects to an inner illuminating string **132** containing a second conductive wire. The inner illuminating string **132** contains within it a plurality of light sources, preferably LEDs, and abuts the circumference of the hole portion **104**. The inner illuminating string **132** is held in place by a plurality of cable clips **130**. When the switch **134** is in the “on” state, the light sources of the inner illuminating string provide light, as is illustrated in FIG. 4. The structure of the inner illuminating string **132** is disclosed in more detail in FIG. 6. In an alternative embodiment, there is no leading wire **112** and the first cord **115** and second cord **117** extend out directly from the power supply **124**. In a preferred embodiment neither cord contains illumination sources, which are contained in the conductive wires located within the illuminating strings.

[0022] FIG. 5 illustrates a bottom view of the illuminated cornhole platform **100**. The front portion **103**, side portions **118**, and back portion **120** are attached to the bottom portion **122** with an off-center hole **104**. Abutting the circumference of the off-center hole **104** is the inner illuminating string **132**, held in place by a plurality of cable clips **130**.

[0023] The inner illuminating string **132** may abut one-half of the total circumference of the hole portion **104**, as illustrated. The inner illuminating string **132** may also extend tangentially to form a “U” shape, wherein the two ends of the inner illuminating string **132** are extending in a straight line. In other embodiments, the inner illuminating string **132** may abut only one quarter of the total circumference of the hole portion **104**. In any event, the inner illuminating string **132** may be placed in such a way as to not interfere or obstruct the hole portion **104** in order to allow a clear area for a bean bag to pass through.

[0024] In a preferred embodiment, as is illustrated in FIG. 5, the inner illumination string **132** abuts no more than half of the circumference of the hole portion **104**, oriented on the semi-circle closest to the front portion. With this set up, a player looking at the cornhole platform **100** from the front portion would not directly see or be exposed to the inner illumination string **132**. This is desirable because light will still reflect off of the side of the hole portion **104**, without shining light directly at the player. Thus, the player can clearly identify the hole portion’s location without having to

directly stare at a light source. An alternative embodiment of FIG. 5 is illustrated in FIG. 8, wherein the player is capable of seeing the inner illuminating string **132**. This may be desired if the player wishes to have a view of the inner illuminating string **132**.

[0025] FIG. 6 illustrates a cutaway view of an illuminating string **140**. An insulated tube **146** contains a conductive wire **142** with a positive and negative electrical end. The conductive wire **142** contains a plurality of illumination sources **144**, which are located within the insulated tube **146**. The illumination sources **144** in some embodiments may be Light Emitting Diodes (LEDs) or alternatively incandescent lights. The insulated tube **146** may be made of any suitable flexible material, such as polyethylene or vinyl. Ideally, the insulated tube **146** is made of material which clear enough to permit light from the light sources **144** to pass through the material. For example, clear polyethylene would permit light to pass through the material.

[0026] The illuminating string **140** may in some embodiments represent the interior structure of both the outer illuminating string and the inner illuminating string. In other embodiments, the inner illuminating string and outer illuminating string may have illumination sources spaced out at different intervals or have light sources of differing frequencies (i.e., color).

[0027] FIG. 7 illustrates an exploded view of the tee adapter **114** of FIG. 1, and the tee adapter’s interaction with the outer illuminating string **102** (see FIG. 1). The tee adapter **114** has two attachment ends **150** with a singular bottom opening **152** perpendicular to the attachment ends **150**. The first cord **115** attaches to the first conductive wire **144**, and is placed through the bottom opening **152** and exits the attachment end **150**. The first cord **115** ends right before the bottom opening **152**, as the first cord **115** does not contain illumination sources while the first conductive wire **144** does.

[0028] Each attachment end **150** contains a number of ribs **154**, although in other embodiments there may only be one rib per attachment end **150**. Each rib has a radius which is slightly larger than an interior radius of the insulated tube **146**. In this manner, placing the insulated tube over the attachment end will cause the tube to deform over the ribs **154**, causing the insulated tube **146** to structurally lock into place with the tee adapter **114** and form a seal.

What is claimed is:

1. An illuminated cornhole platform, comprising:
 - a rectangular platform comprising a top portion, at least two side portions, a front portion, a hole portion, at least one leg portion, and a back portion;
 - an outer illuminating string comprising a first end, a second end, a main length, a first insulated tube, and a first conductive wire with a plurality of illumination sources,
 - wherein the main length of the outer illuminating string is placed along a majority of an outer perimeter of the rectangular platform, the outer illuminating string held in place by a first plurality of cable clips;
 - an inner illuminating string comprising a first end, a second end, a main length, a second insulated tube, and a second conductive wire with a plurality of illumination sources,
 - wherein the inner illuminating string is placed along a lower circumference of the hole portion, abutting at

- least one half of the lower circumference, the inner illuminating string held in place with a second plurality of cable clips.
2. The illuminated cornhole platform of claim 1, wherein the plurality of illumination sources are light emitting diodes.
 3. The illuminated cornhole platform of claim 1, wherein the plurality of illumination sources are incandescent lights.
 4. The illuminated cornhole platform of claim 1, wherein the inner illuminating string does not obstruct the hole portion.
 5. The illuminated cornhole platform of claim 1, wherein the insulated tube is polyethylene.
 6. The illuminated cornhole platform of claim 1, wherein the insulated tube is vinyl.
 7. The illuminated cornhole platform of claim 1, wherein the insulated tube is clear.
 8. The illuminated cornhole platform of claim 1, wherein the insulated tube is opaque.
 9. The illuminated cornhole platform of claim 1, wherein the plurality of illumination sources are spaced evenly along the first conductive wire.

10. The illuminated cornhole platform of claim 1, wherein the plurality of illumination sources are spaced evenly along the second conductive wire.
11. The illuminated cornhole platform of claim 1, wherein the inner illuminating string abuts approximately one half of the lower circumference of the hole portion.
12. The illuminated cornhole platform of claim 14, wherein the inner illuminating string tangentially extends from the circumference of the hole portion to form a “U” shape.
13. The illuminated cornhole platform of claim 1, wherein the first plurality of cable clips and the second plurality of cable clips are affixed to the cornhole platform by a fastener.
14. The illuminated cornhole platform of claim 1, wherein the first plurality of cable clips and the second plurality of cable clips are affixed to the cornhole platform by an adhesive.
15. The illuminated cornhole platform of claim 1, wherein the first plurality of cable clips and the second plurality of cable clips are of the same design.

* * * * *