



US 20170360371A1

(19) **United States**

(12) **Patent Application Publication**
Hacker et al.

(10) **Pub. No.: US 2017/0360371 A1**

(43) **Pub. Date: Dec. 21, 2017**

(54) **ENDOTRACHEAL TUBE APPARATUS**

A61B 5/04 (2006.01)

A61B 5/0488 (2006.01)

(71) Applicant: **MEDTRONIC XOMED, INC.**,
Jacksonville, FL (US)

(Continued)

(72) Inventors: **David C. Hacker**, Jacksonville, FL (US); **Maria Charles Vijay Stanislaus**, Irvine, CA (US); **Wenjeng Li**, Saint Johns, FL (US); **Dwayne S. Yamasaki**, St. Augustine, FL (US); **William C. Brunnett**, Mission Viejo, CA (US); **Kevin L. McFarlin**, St. Johns, FL (US); **James Britton Hissong**, Jacksonville, FL (US); **Robert K. Vaccaro**, Ponte Vedra Beach, FL (US); **John M. Murphy**, Jacksonville, FL (US); **Carla A. Pagotto**, Ponte Vedra Beach, FL (US); **Tino Schuler**, Jacksonville, FL (US)

(52) **U.S. Cl.**
CPC *A61B 5/6853* (2013.01); *A61N 1/0519* (2013.01); *A61N 1/0517* (2013.01); *A61M 16/0459* (2014.02); *A61B 1/00082* (2013.01); *A61B 1/04* (2013.01); *A61B 1/07* (2013.01); *A61B 1/267* (2013.01); *A61B 1/2673* (2013.01); *A61B 5/01* (2013.01); *A61B 5/04012* (2013.01); *A61B 5/0488* (2013.01); *A61B 5/04886* (2013.01); *A61B 5/0492* (2013.01); *A61B 5/062* (2013.01); *A61B 5/064* (2013.01); *A61B 5/065* (2013.01); *A61B 5/07* (2013.01); *A61B 5/11* (2013.01); *A61M 16/04* (2013.01); *A61M 16/0434* (2013.01); *A61M 16/0463* (2013.01); *A61M 16/0488* (2013.01); *A61B 1/005* (2013.01); *A61M 16/0411* (2014.02); *A61B 2562/0209* (2013.01); *A61B 2562/0219* (2013.01); *A61B 2562/0261* (2013.01); *A61B 2562/046* (2013.01); *A61B 1/015* (2013.01); *A61B 1/018* (2013.01); *A61M 16/0825* (2014.02); *A61B 5/0421* (2013.01); *A61M 2205/0233* (2013.01); *A61M 2205/0294* (2013.01); *A61M 2205/3306* (2013.01); *A61M 2205/332* (2013.01); *A61M 2205/3344* (2013.01); *A61M 2205/3368* (2013.01); *A61M 2205/3546* (2013.01); *A61M 2205/3569* (2013.01); *A61M 2205/3592* (2013.01); *A61M 2205/6054* (2013.01); *A61M 2210/065* (2013.01); *A61M 2230/08* (2013.01); *A61B 1/00147* (2013.01)

(73) Assignee: **MEDTRONIC XOMED, INC.**,
Jacksonville, FL (US)

(21) Appl. No.: **15/692,738**

(22) Filed: **Aug. 31, 2017**

Related U.S. Application Data

(63) Continuation of application No. 14/716,351, filed on May 19, 2015, which is a continuation of application No. 12/896,578, filed on Oct. 1, 2010, now Pat. No. 9,037,226.

(60) Provisional application No. 61/248,294, filed on Oct. 2, 2009.

Publication Classification

(51) **Int. Cl.**
A61B 5/00 (2006.01)
A61M 16/04 (2006.01)
A61B 1/00 (2006.01)
A61B 1/04 (2006.01)
A61B 1/07 (2006.01)
A61B 1/267 (2006.01)
A61B 5/01 (2006.01)

(57) **ABSTRACT**

An apparatus for monitoring EMG signals of a patient's laryngeal muscles includes an endotracheal tube having an exterior surface. Conductive electrodes are formed on the endotracheal tube. The conductive electrodes are configured to receive the EMG signals from the laryngeal muscles when the endotracheal tube is placed in a trachea of the patient. At least wireless sensor is formed on the endotracheal tube, and is configured to wirelessly transmit information to a processing apparatus.

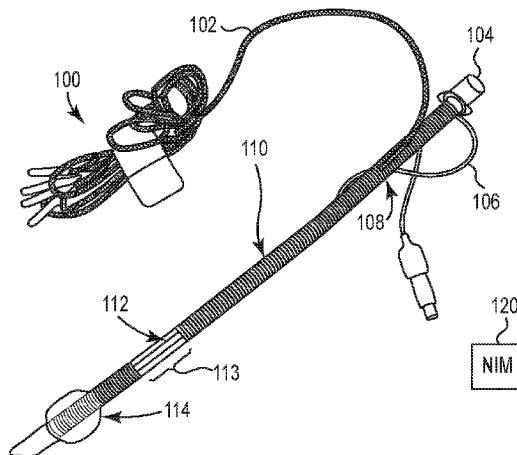

	Publication Classification		
(51)	Int. Cl.	<i>A61N 1/05</i>	(2006.01)
		<i>A61B 1/005</i>	(2006.01)
	<i>A61B 5/0492</i>	<i>A61B 1/015</i>	(2006.01)
	<i>A61B 5/06</i>	<i>A61B 1/018</i>	(2006.01)
	<i>A61B 5/07</i>	<i>A61M 16/08</i>	(2006.01)
	<i>A61B 5/11</i>	<i>A61B 5/042</i>	(2006.01)

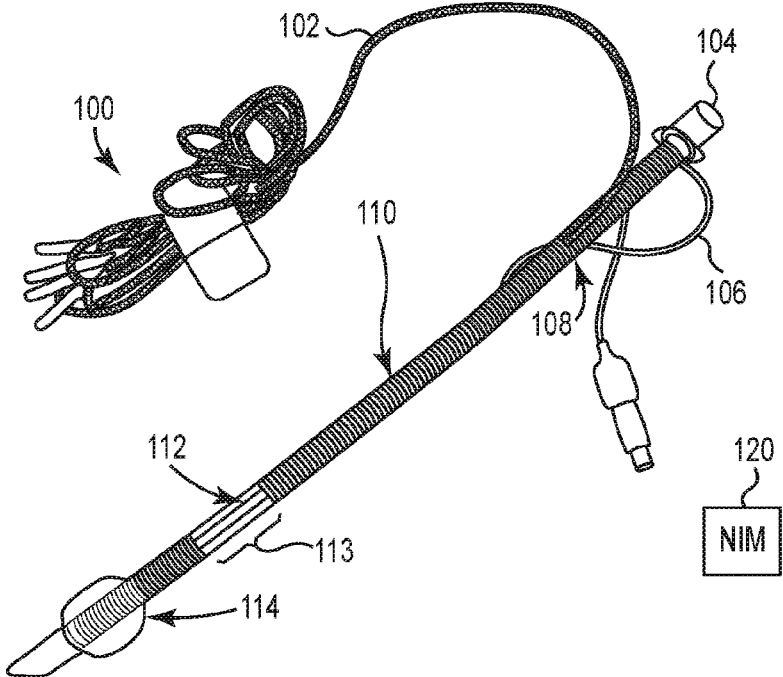

Fig. 1

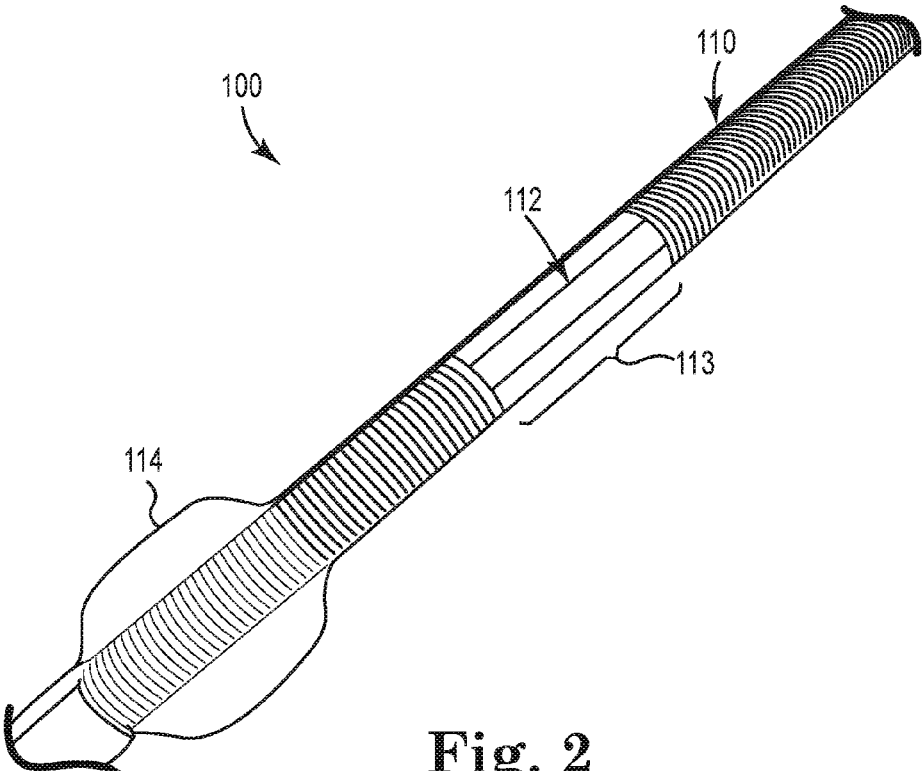

Fig. 2

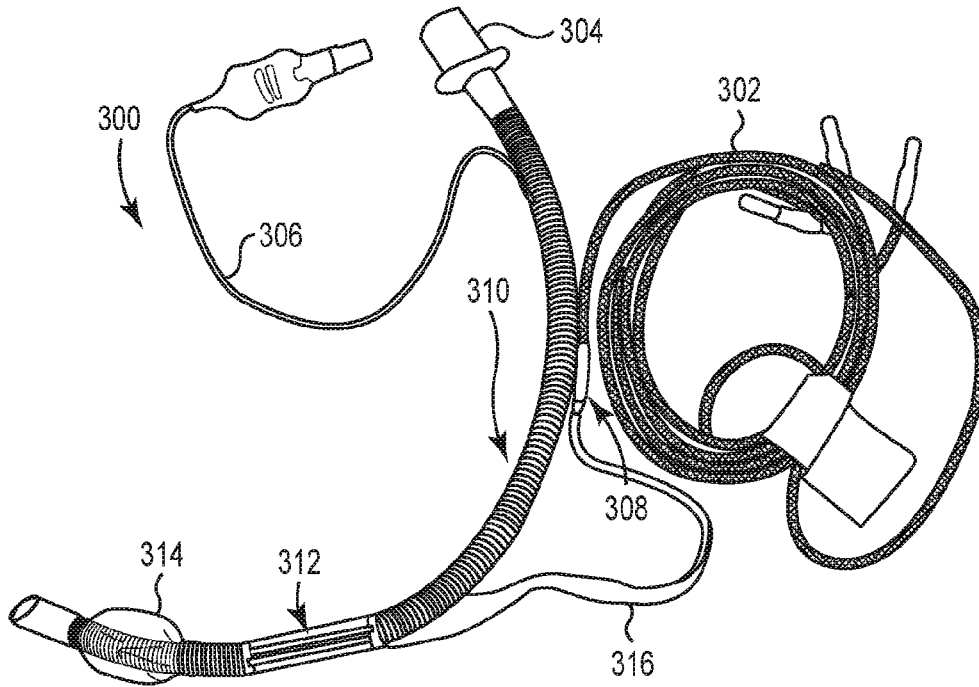

Fig. 3

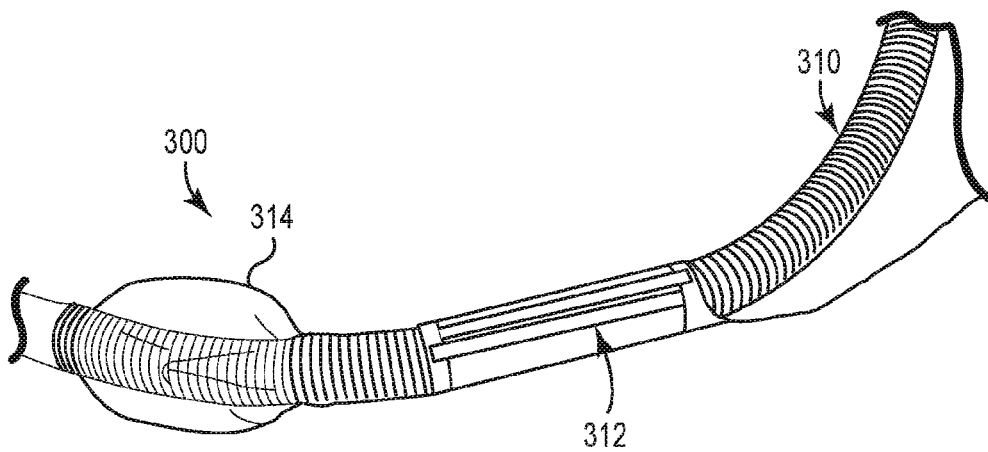
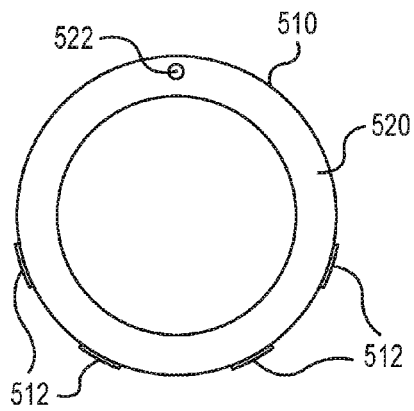
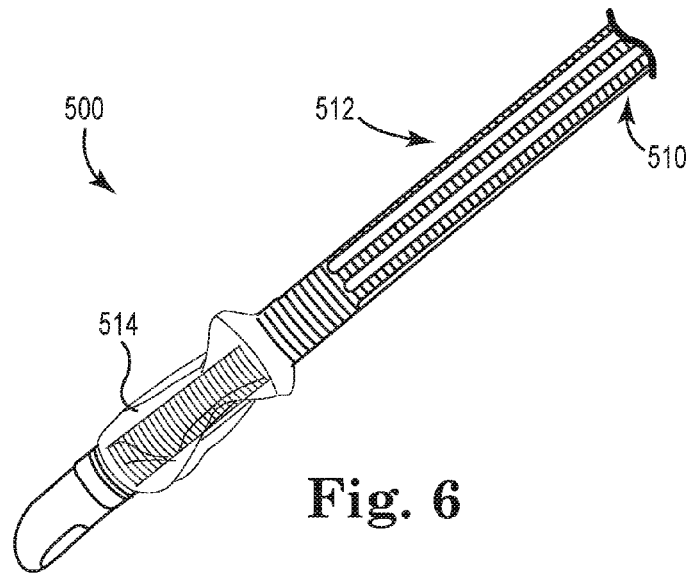
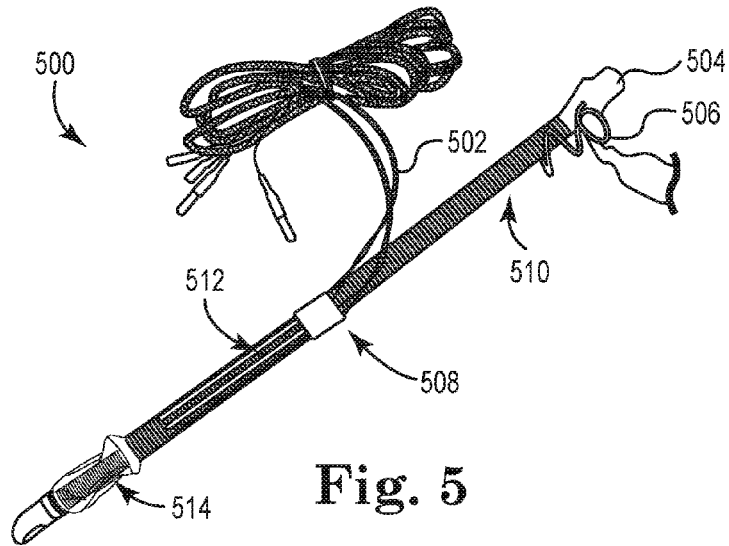
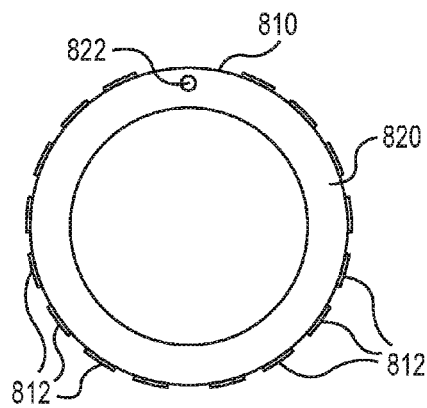
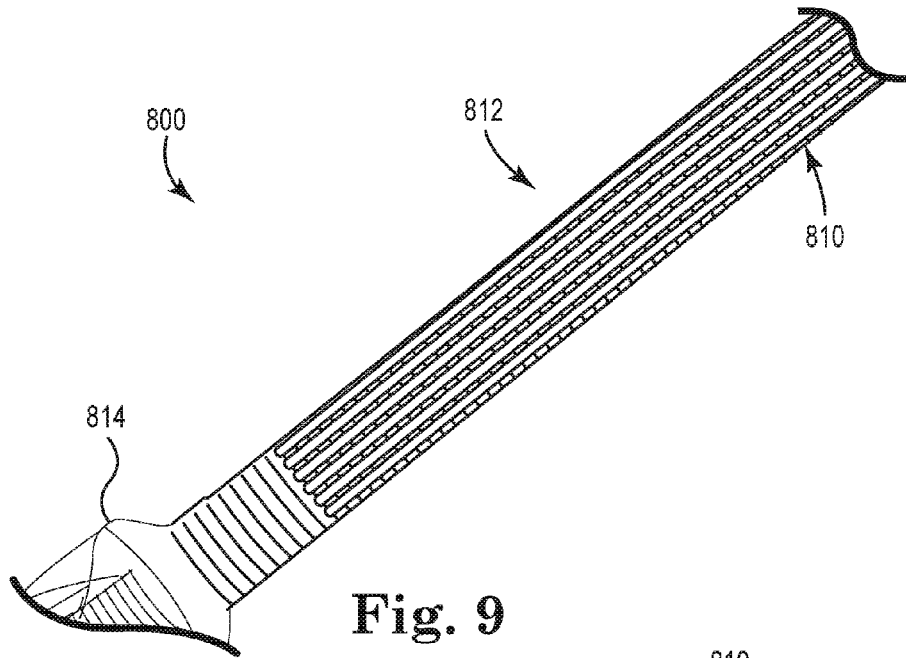
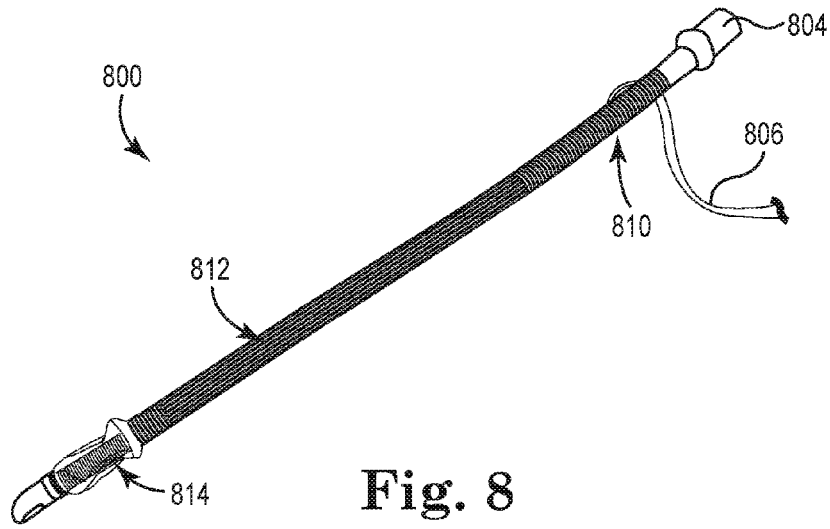

Fig. 4





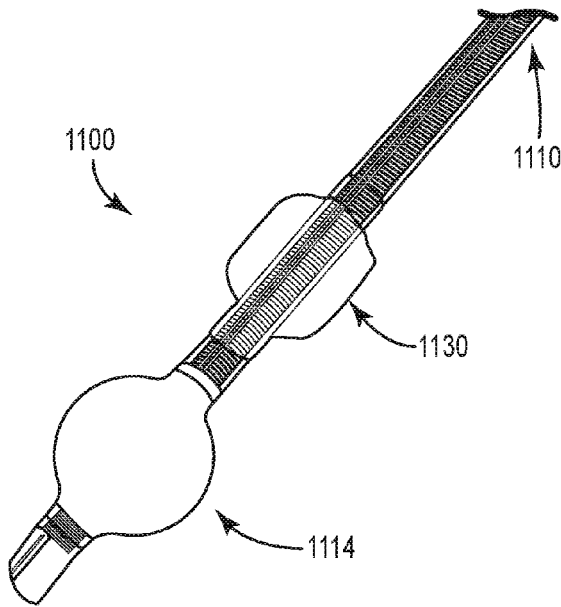

Fig. 11

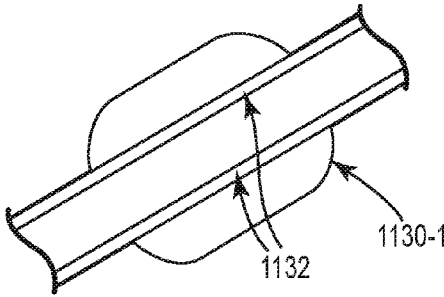

Fig. 12A

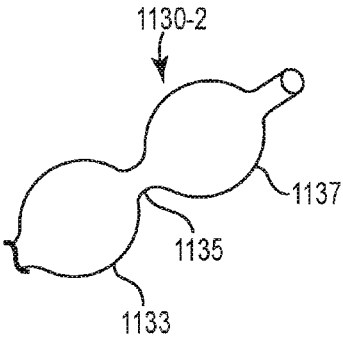

Fig. 12B

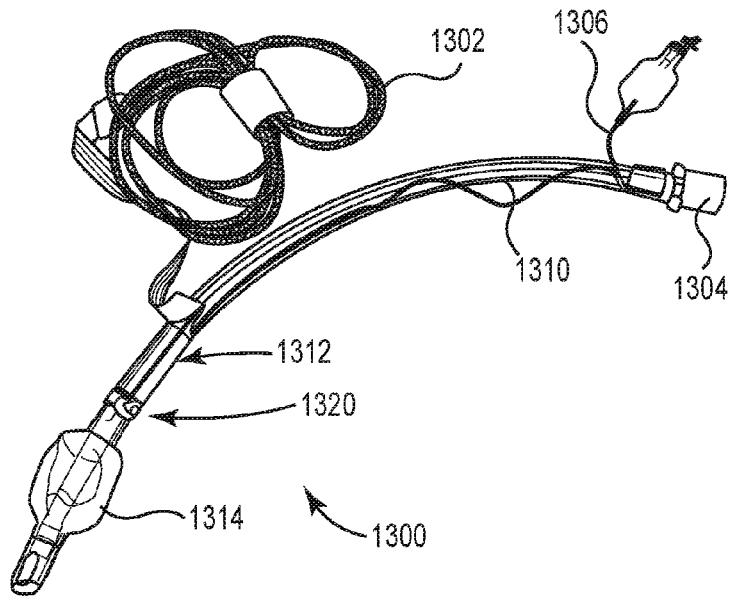

Fig. 13

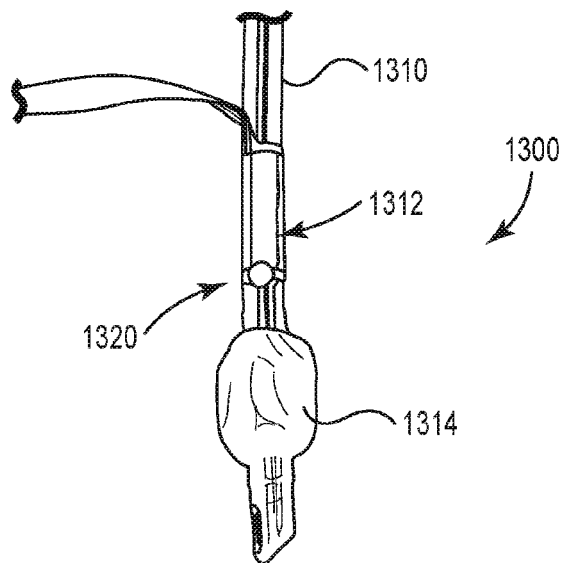
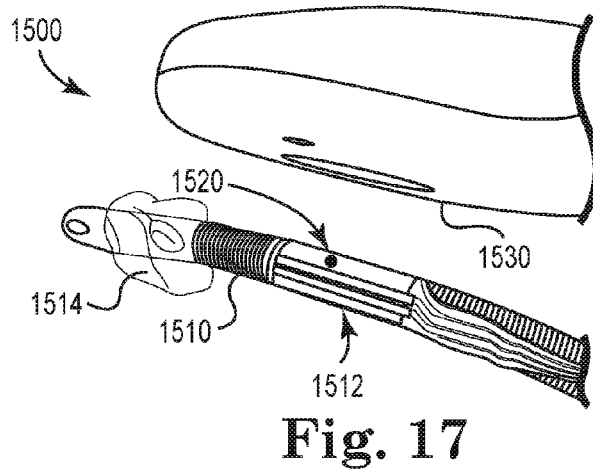
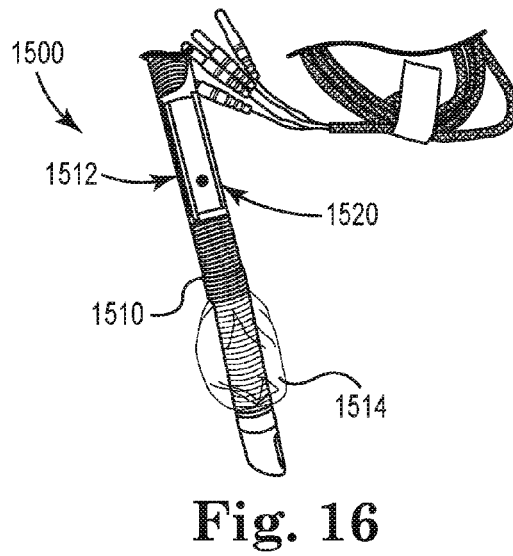
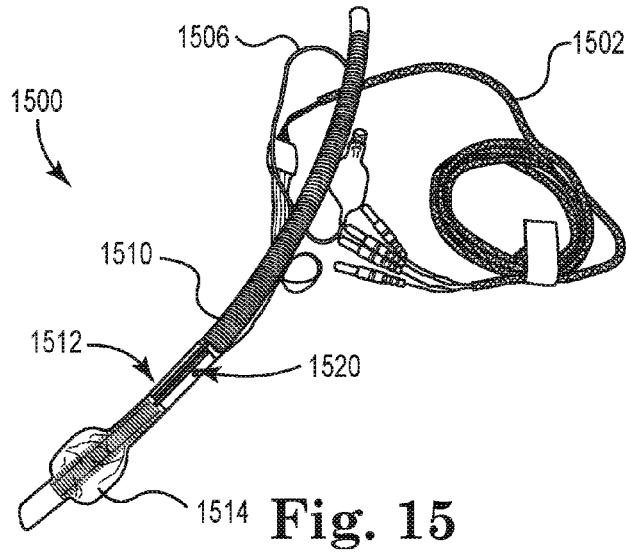

Fig. 14



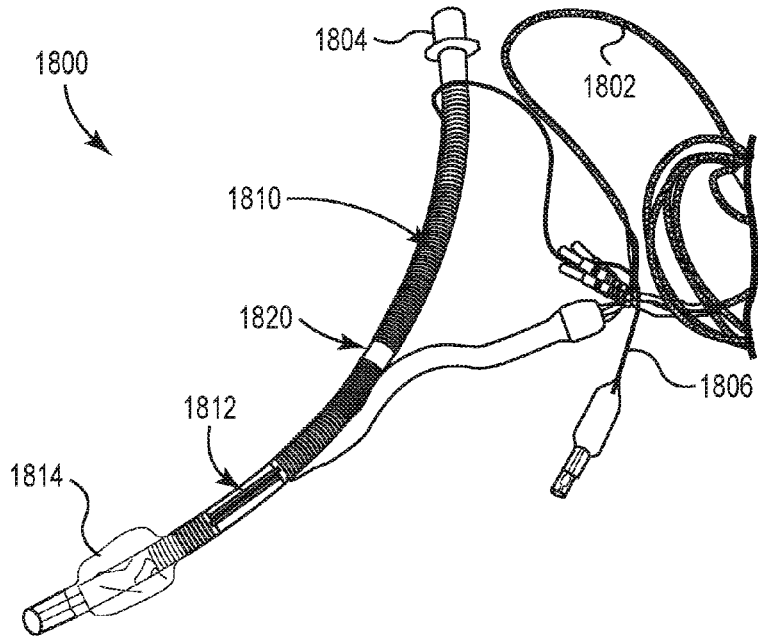

Fig. 18

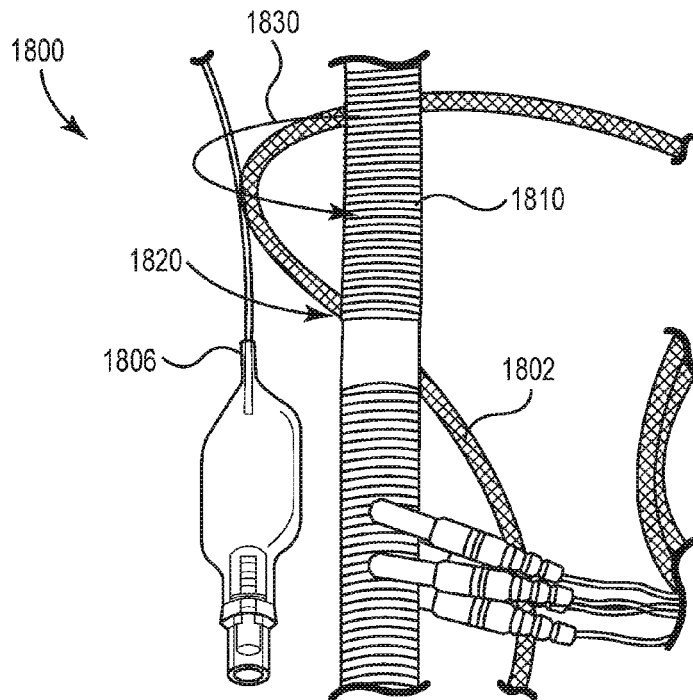

Fig. 19

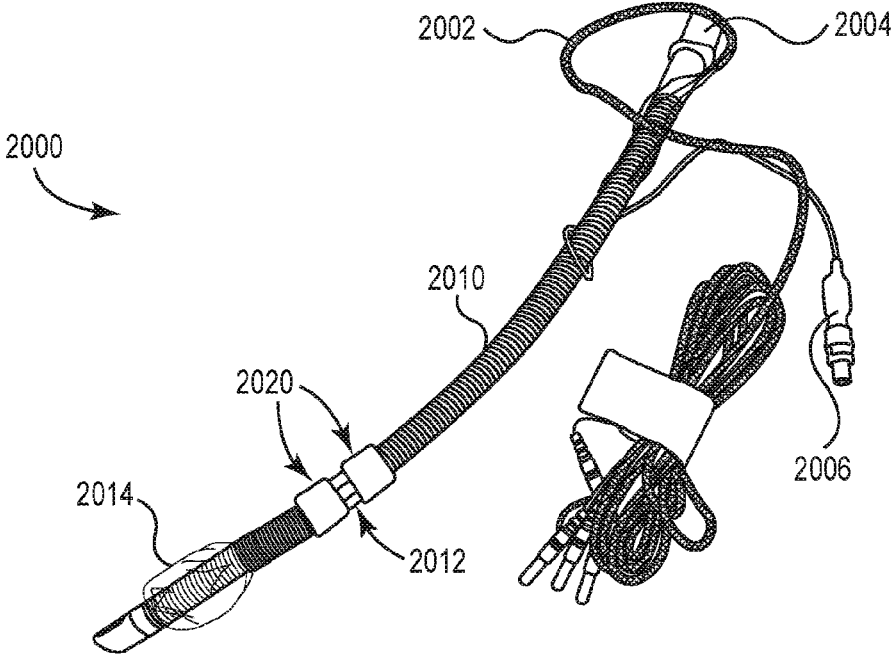

Fig. 20

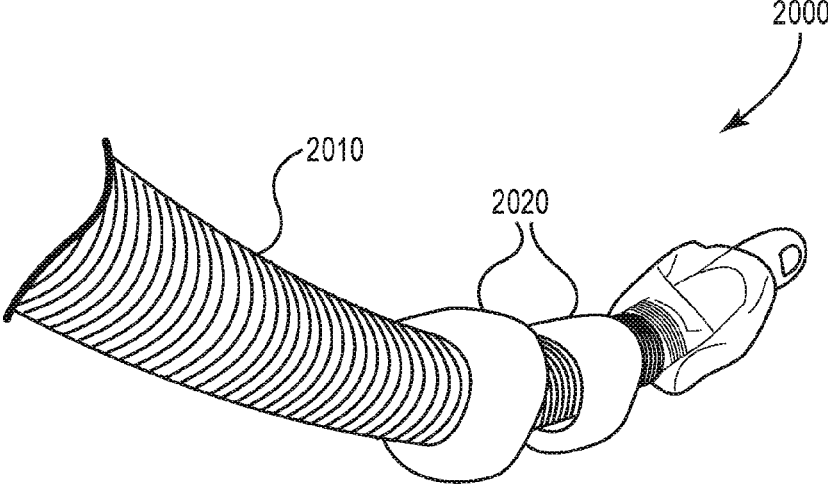

Fig. 21

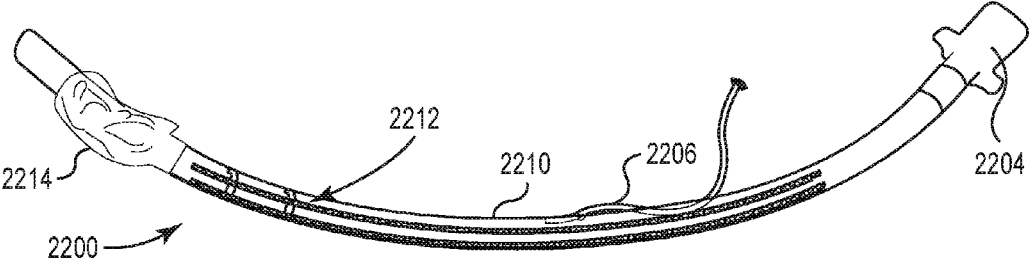

Fig. 22

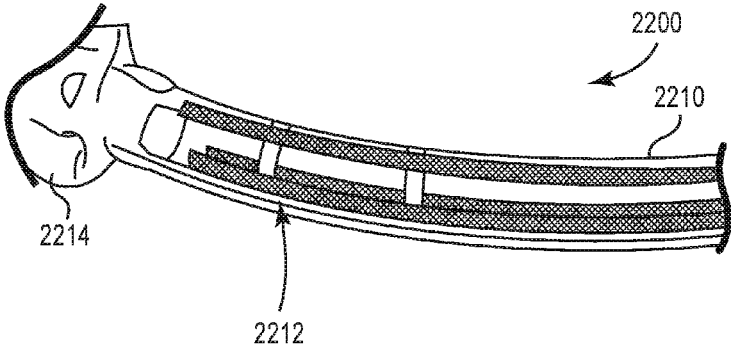

Fig. 23

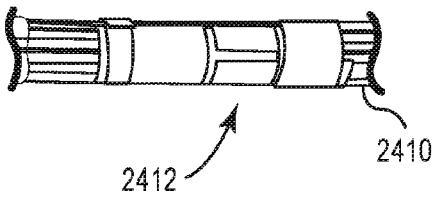

Fig. 25

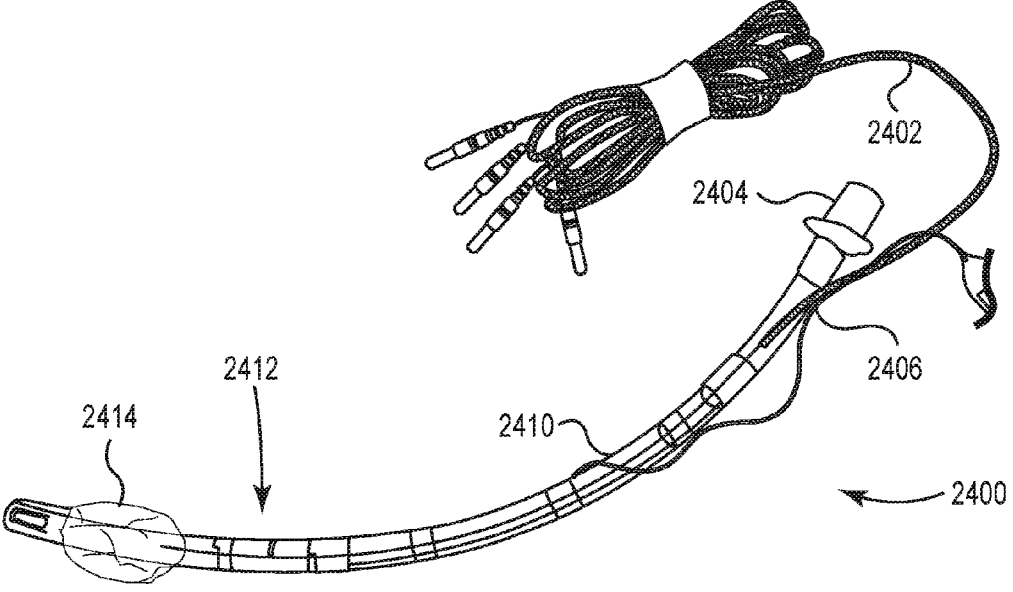

Fig. 24

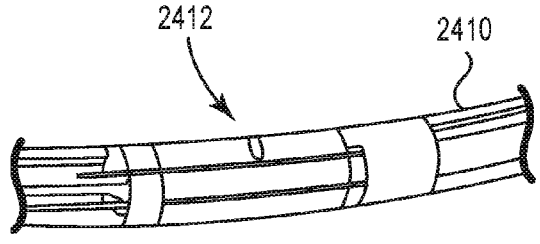

Fig. 26

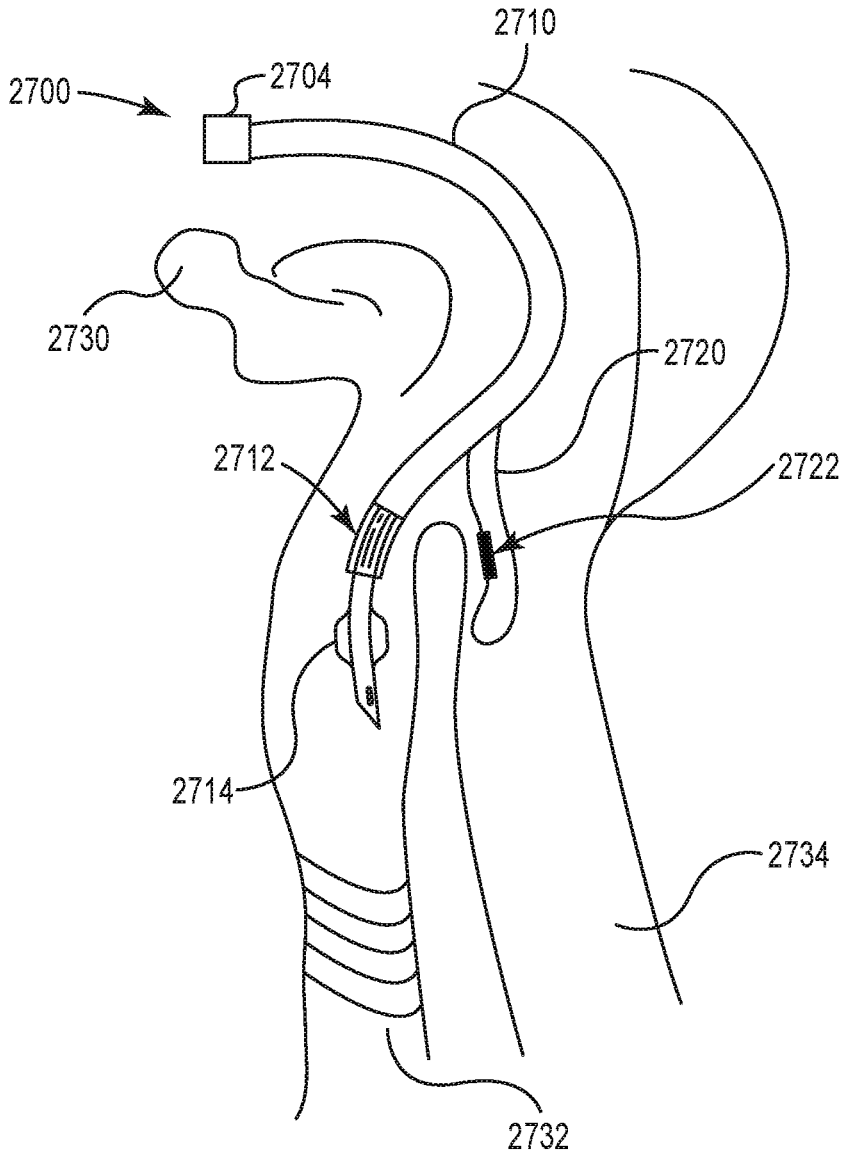

Fig. 27

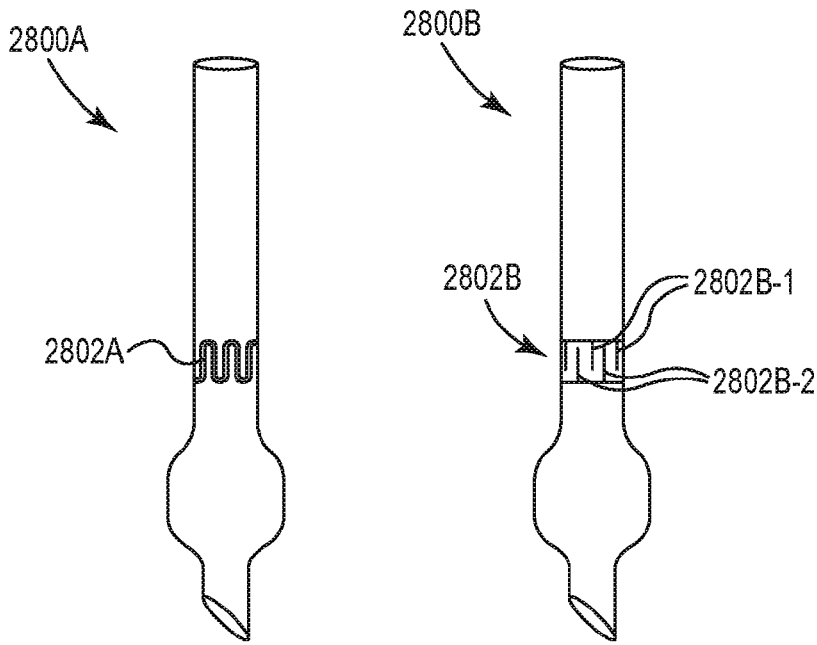

Fig. 28A **Fig. 28B**

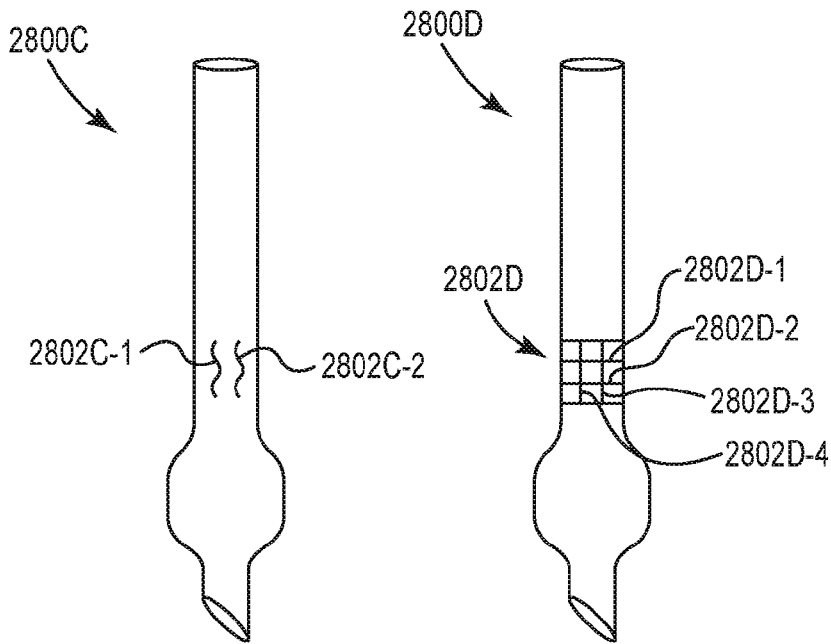

Fig. 28C **Fig. 28D**

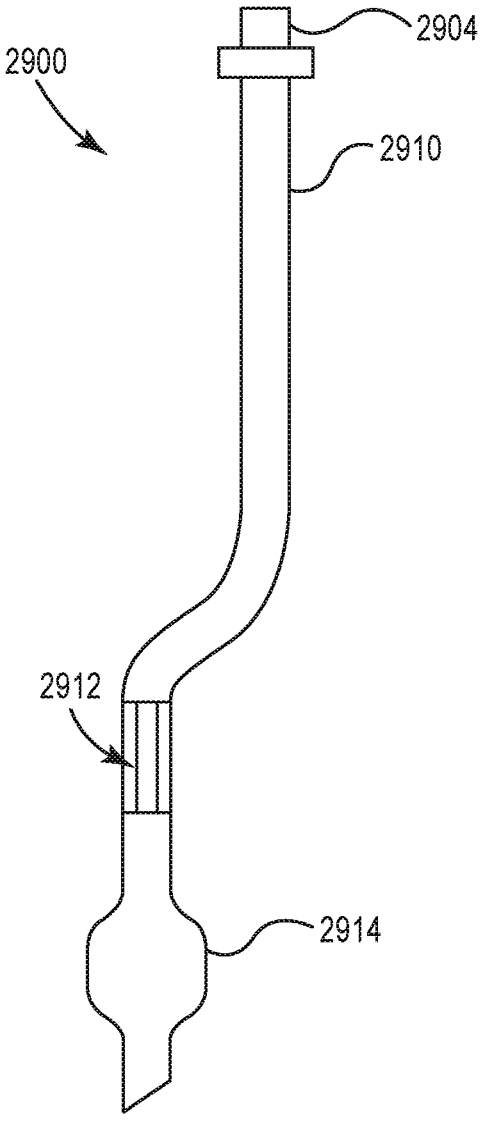

Fig. 29

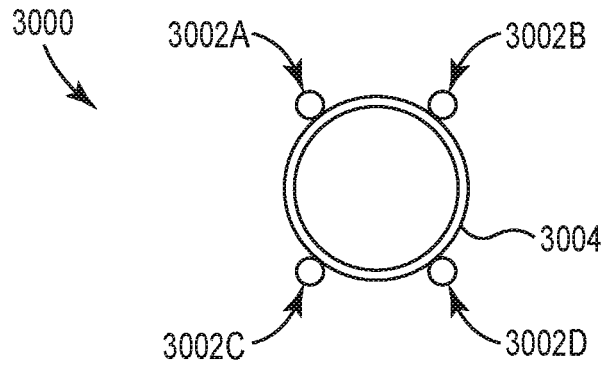

Fig. 30

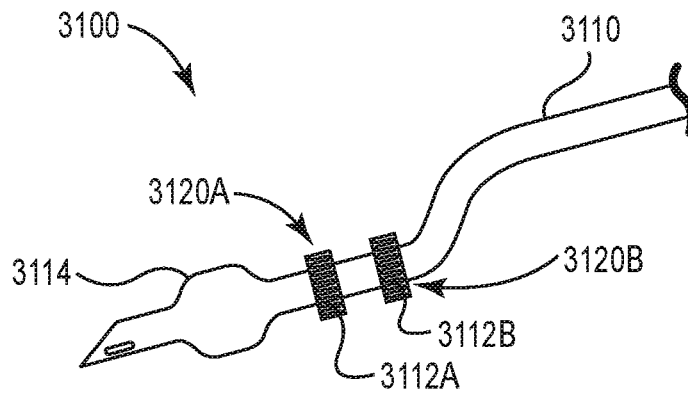

Fig. 31

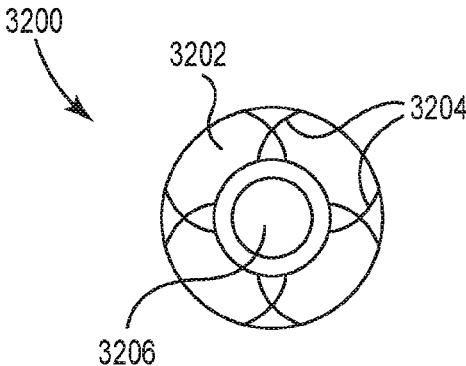

Fig. 32

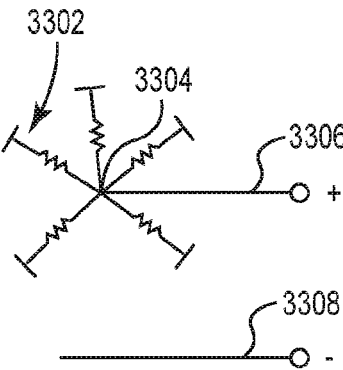

Fig. 33

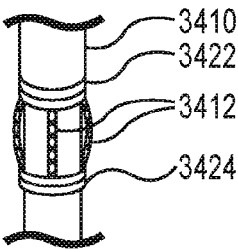

Fig. 34

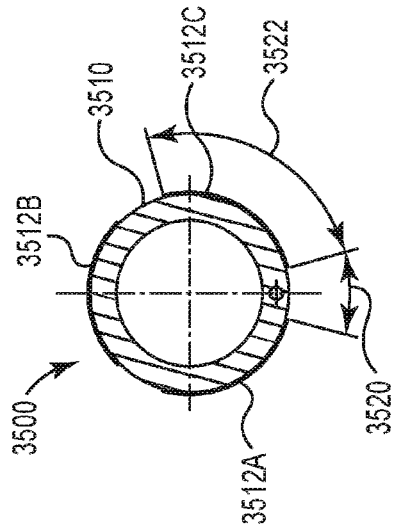

Fig. 35C

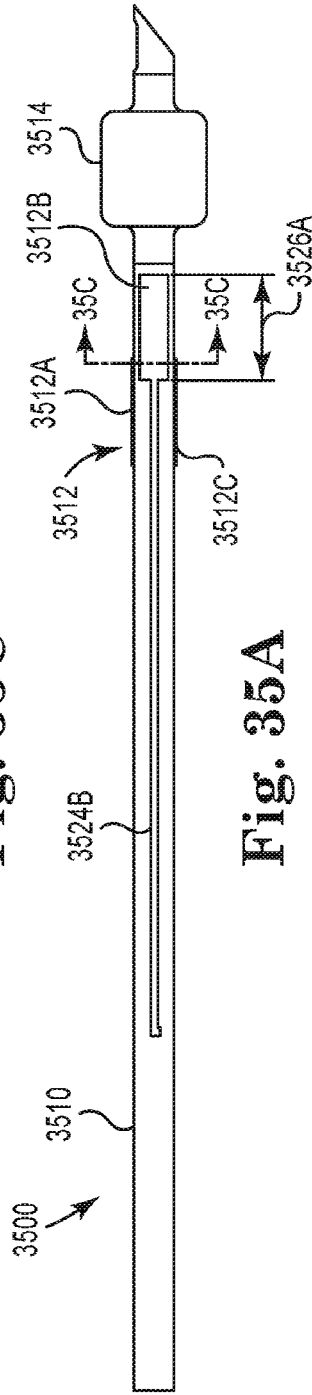

Fig. 35A

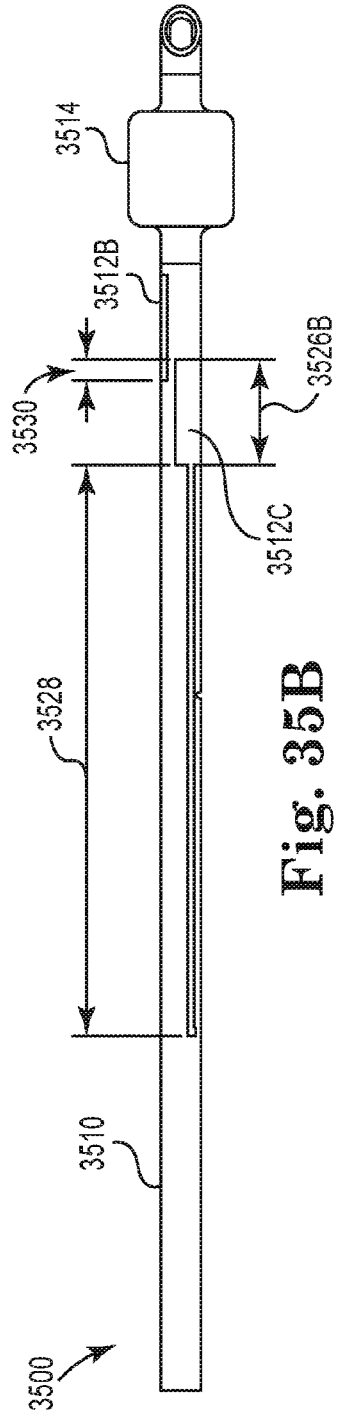

Fig. 35B

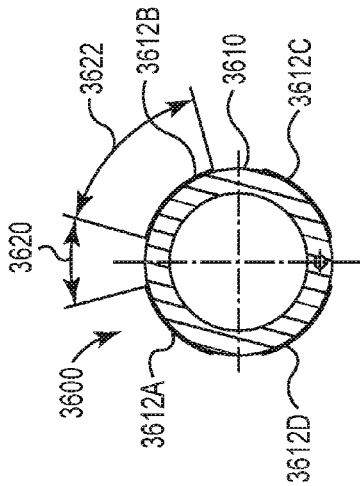

Fig. 36C

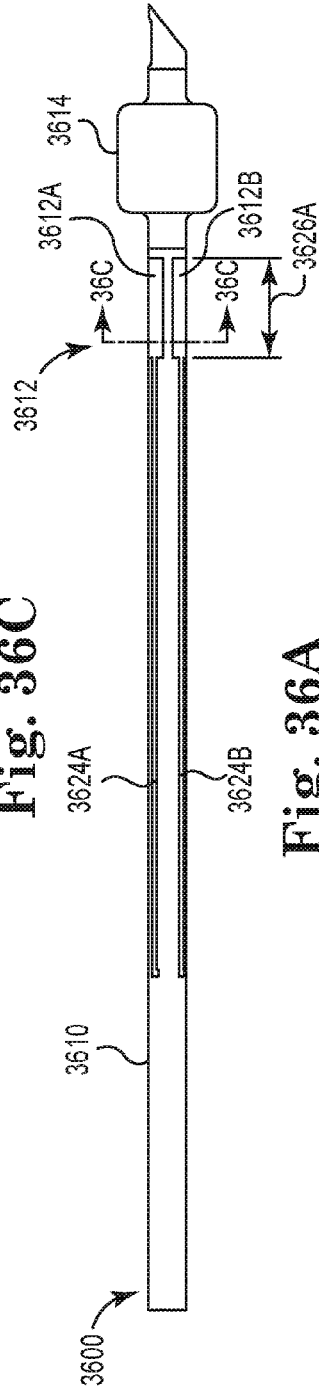

Fig. 36A

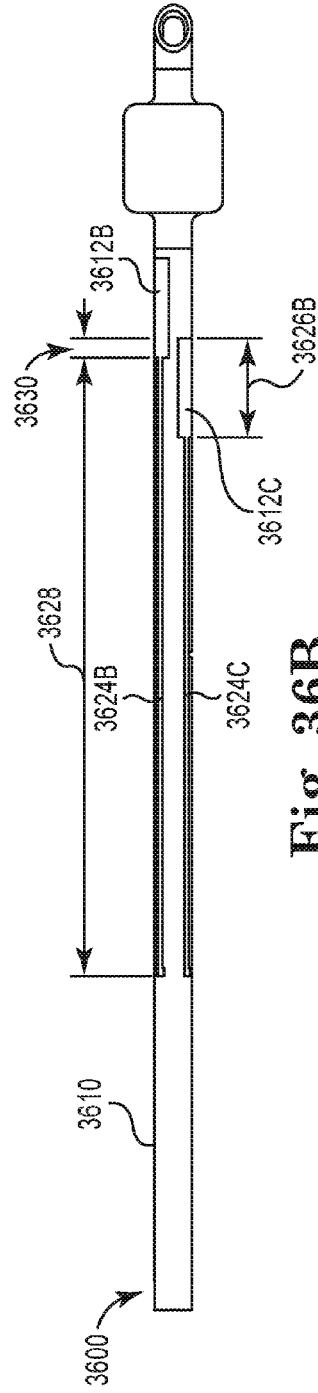

Fig. 36B

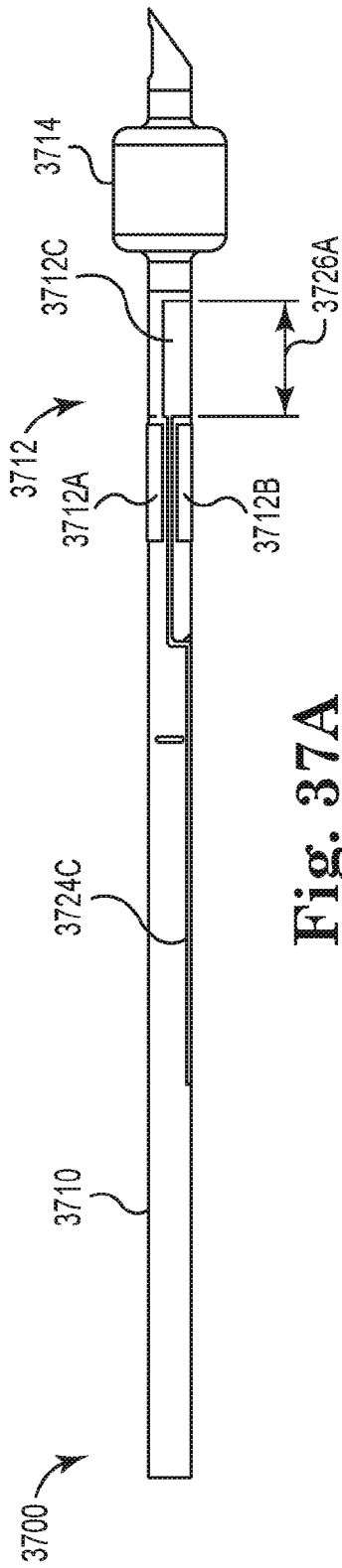

Fig. 37A

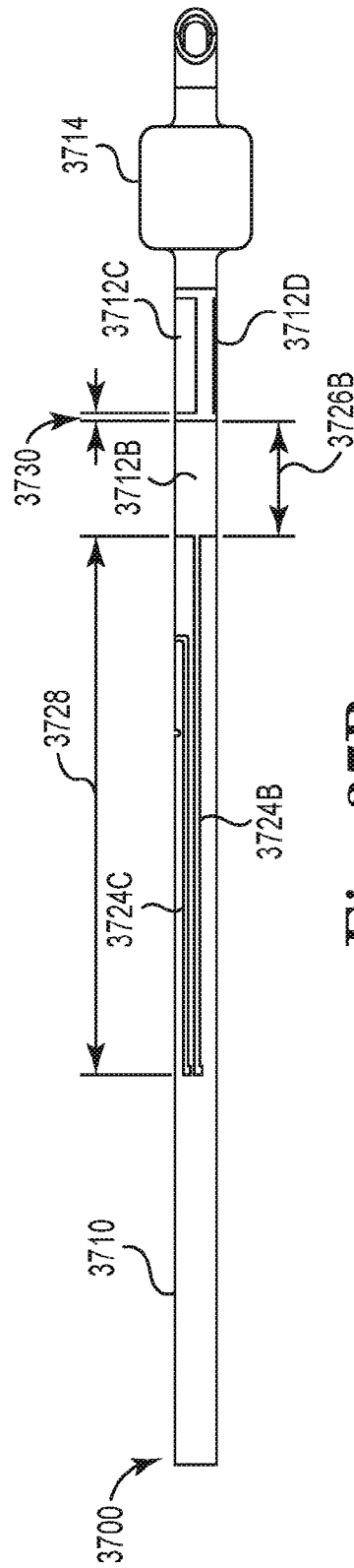

Fig. 37B

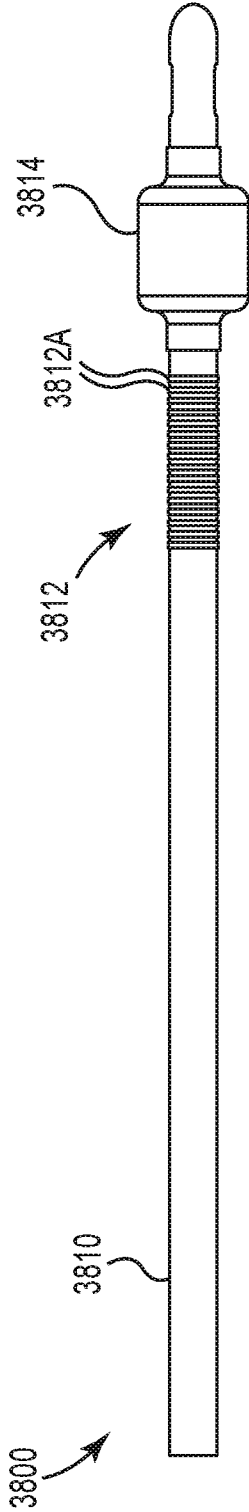

Fig. 38

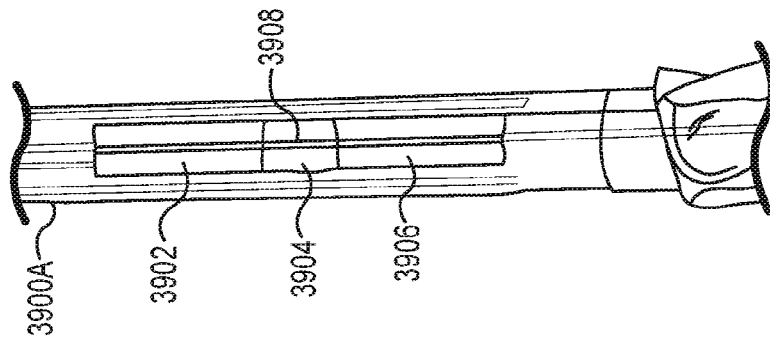

Fig. 39A

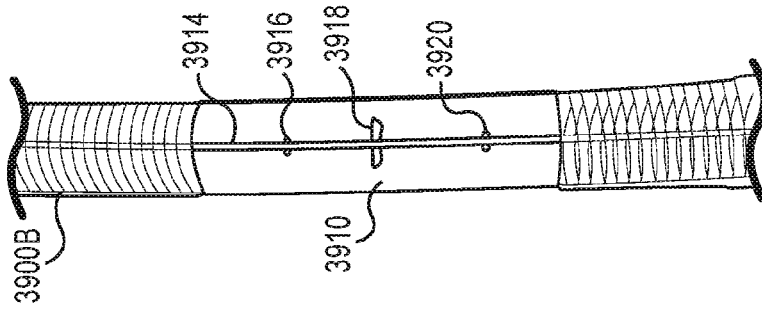

Fig. 39B

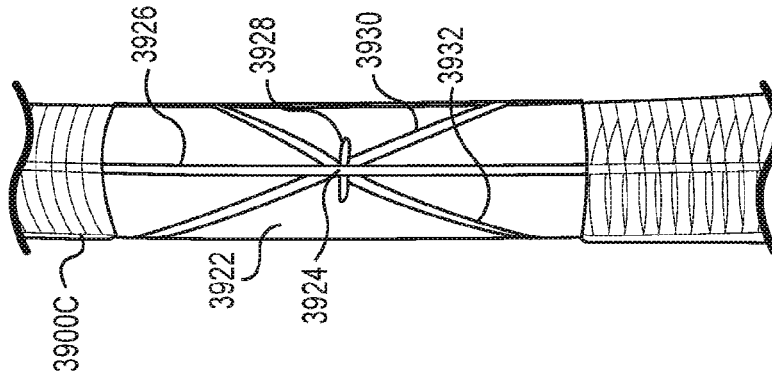

Fig. 39C

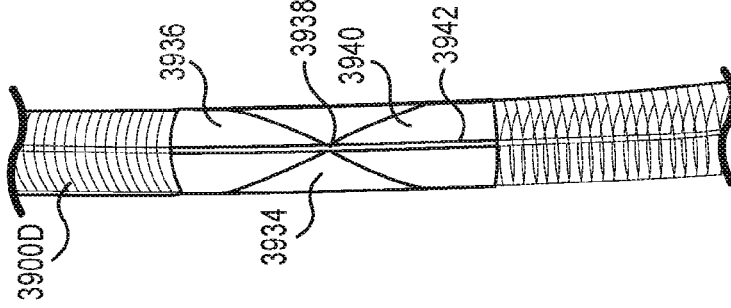

Fig. 39D

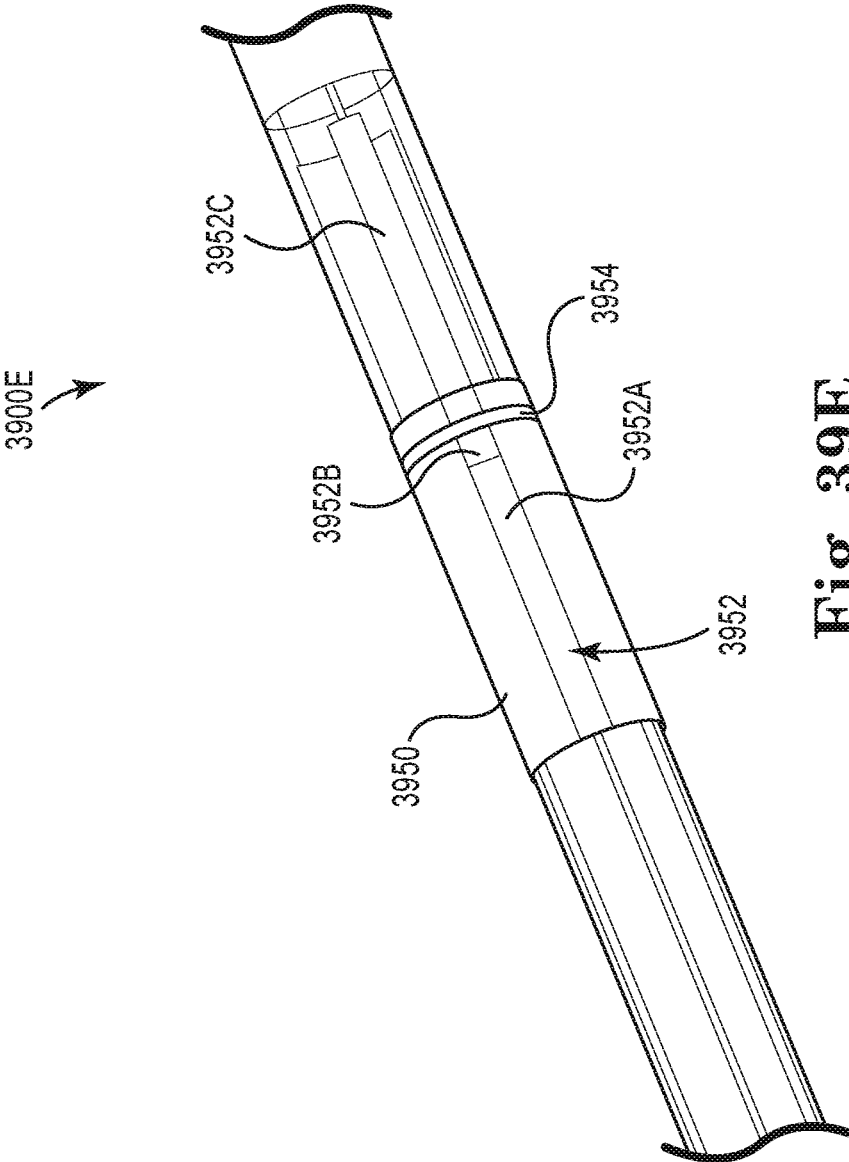

Fig. 39E

ENDOTRACHEAL TUBE APPARATUS**CROSS-REFERENCE TO RELATED APPLICATIONS**

[0001] This application is a continuation of U.S. patent application Ser. No. 14/716,351, filed May 19, 2015, entitled “Endotracheal Tube Apparatus”, and bearing Attorney Docket No. M190.350.103/P0035756.USC12, which is a continuation of U.S. patent application Ser. No. 12/896,578, filed Oct. 1, 2010, entitled “Endotracheal Tube Apparatus”, and bearing Attorney Docket No. M190.350.102/P0035756.02, now U.S. Pat. No. 9,037,226, which claims priority under 35 U.S.C. §119(e)(1) to U.S. Provisional Patent Application Ser. No. 61/248,294, filed Oct. 2, 2009, entitled “Endotracheal Tube Apparatus”, and bearing Attorney Docket No. M190.350.101/P0035756.00; and the entire teachings of which are incorporated herein by reference.

BACKGROUND

[0002] Endotracheal tubes include electrodes that are designed to make contact with a patient’s vocal cords to facilitate electromyographic (EMG) monitoring of the vocal cords during surgery when connected to an EMG monitoring device. Endotracheal tubes provide an open airway for patient ventilation, and provide for monitoring of EMG activity of the intrinsic laryngeal musculature when connected to an appropriate EMG monitor. Endotracheal tubes can provide continuous monitoring of the nerves supplying the laryngeal musculature during surgical procedures.

SUMMARY

[0003] One embodiment is directed to an apparatus for monitoring EMG signals of a patient’s laryngeal muscles. The apparatus includes an endotracheal tube having an exterior surface. Conductive ink electrodes are formed on the exterior surface of the endotracheal tube. The conductive ink electrodes are configured to receive the EMG signals from the laryngeal muscles when the endotracheal tube is placed in a trachea of the patient. At least one conductor is coupled to the conductive ink electrodes and is configured to carry the EMG signals received by the conductive ink electrodes to a processing apparatus.

BRIEF DESCRIPTION OF THE DRAWINGS

[0004] FIG. 1 shows an EMG endotracheal tube made from extruded polymer according to one embodiment.

[0005] FIG. 2 shows a close-up view of a portion of the endotracheal tube shown in FIG. 1 according to one embodiment.

[0006] FIG. 3 shows an EMG endotracheal tube made from PVC according to one embodiment.

[0007] FIG. 4 shows a close-up view of a portion of the endotracheal tube shown in FIG. 3 according to one embodiment.

[0008] FIG. 5 shows an EMG endotracheal tube with conductive ink electrodes printed on the tube according to one embodiment.

[0009] FIG. 6 shows a close-up view of a portion of the endotracheal tube shown in FIG. 5 according to one embodiment.

[0010] FIG. 7 is a diagram illustrating a cross-sectional view of the endotracheal tube shown in FIG. 5 according to one embodiment.

[0011] FIG. 8 shows an EMG endotracheal tube with multiple pairs of conductive ink electrodes printed around the circumference of the tube according to one embodiment.

[0012] FIG. 9 shows a close-up view of a portion of the endotracheal tube shown in FIG. 8 according to one embodiment.

[0013] FIG. 10 is a diagram illustrating a cross-sectional view of the endotracheal tube shown in FIG. 8 according to one embodiment.

[0014] FIG. 11 shows an EMG endotracheal tube with a primary cuff and a secondary cuff according to one embodiment.

[0015] FIG. 12A shows the secondary cuff of the endotracheal tube shown in FIG. 11 with conductive ink electrodes printed on the secondary cuff according to one embodiment.

[0016] FIG. 12B shows the secondary cuff of the endotracheal tube shown in FIG. 11 according to another embodiment.

[0017] FIG. 13 shows an EMG endotracheal tube with a visual indicator for tracking and verifying electrode location according to one embodiment.

[0018] FIG. 14 shows a close-up view of a portion of the endotracheal tube shown in FIG. 13 according to one embodiment.

[0019] FIG. 15 shows an EMG endotracheal tube with a magnet indicator for tracking and verifying electrode location according to one embodiment.

[0020] FIGS. 16 and 17 show close-up views of a portion of the endotracheal tube shown in FIG. 15 according to one embodiment.

[0021] FIG. 18 shows an EMG endotracheal tube with a coupling adapter to provide rotational freedom according to one embodiment.

[0022] FIG. 19 shows a close-up view of a portion of the endotracheal tube shown in FIG. 18 according to one embodiment.

[0023] FIG. 20 shows an EMG endotracheal tube with ribs on the top and bottom of the EMG electrodes according to one embodiment.

[0024] FIG. 21 shows a close-up view of a portion of the endotracheal tube shown in FIG. 20 according to one embodiment.

[0025] FIG. 22 shows an EMG endotracheal tube with conductive tape on the surface of the tube for recording EMG signals according to one embodiment.

[0026] FIG. 23 shows a close-up view of a portion of the endotracheal tube shown in FIG. 22 according to one embodiment.

[0027] FIG. 24 shows an EMG endotracheal tube with a custom extruded PVC tube according to one embodiment.

[0028] FIGS. 25 and 26 show close-up views of a portion of the endotracheal tube shown in FIG. 24 according to one embodiment.

[0029] FIG. 27 shows an EMG endotracheal tube positioned within a patient’s throat according to one embodiment.

[0030] FIGS. 28A-28D show an EMG endotracheal tube with electrodes having an increased surface area according to various embodiments.

[0031] FIG. 29 shows an EMG endotracheal tube with an overall shape that is curved to match the shape of a human throat according to one embodiment.

[0032] FIG. 30 shows a cross-sectional view of an EMG endotracheal tube with electrodes configured to reduce or eliminate rotational sensitivity according to one embodiment.

[0033] FIG. 31 shows an EMG endotracheal tube with electrodes configured to reduce or eliminate rotational sensitivity according to another embodiment.

[0034] FIG. 32 shows a cuff for an EMG endotracheal tube according to one embodiment.

[0035] FIG. 33 shows an electrical schematic diagram of an electrode array configured to be used in an EMG endotracheal tube according to one embodiment.

[0036] FIG. 34 shows flexible, expanding electrodes configured to be used in an EMG endotracheal tube according to one embodiment.

[0037] FIG. 35A shows a first side view (posterior side) of an EMG endotracheal tube with three electrodes according to one embodiment.

[0038] FIG. 35B shows a second side view (rotated 90 degrees from the view shown in FIG. 35A) of the EMG endotracheal tube shown in FIG. 35A according to one embodiment.

[0039] FIG. 35C is a diagram illustrating a cross-sectional view of the endotracheal tube shown in FIGS. 35A and 35B according to one embodiment.

[0040] FIG. 36A shows a first side view (posterior side) of an EMG endotracheal tube with four electrodes according to one embodiment.

[0041] FIG. 36B shows a second side view (rotated 90 degrees from the view shown in FIG. 36A) of the EMG endotracheal tube shown in FIG. 36A according to one embodiment.

[0042] FIG. 36C is a diagram illustrating a cross-sectional view of the endotracheal tube shown in FIGS. 36A and 36B according to one embodiment.

[0043] FIG. 37A shows a first side view (posterior side) of an EMG endotracheal tube with four electrodes according to another embodiment.

[0044] FIG. 37B shows a second side view (rotated 90 degrees from the view shown in FIG. 37A) of the EMG endotracheal tube shown in FIG. 37A according to one embodiment.

[0045] FIG. 38 shows a side view of an EMG endotracheal tube with a plurality of ring electrodes according to one embodiment.

[0046] FIGS. 39A-39E show EMG endotracheal tubes with tube placement markings according to various embodiments.

DETAILED DESCRIPTION

[0047] FIG. 1 shows an EMG endotracheal tube 100 made from extruded polymer. FIG. 2 shows a close-up view of a portion of the endotracheal tube 100 shown in FIG. 1. Endotracheal tube 100 includes solid wires 102, fitting 104, cuff inflating conduit 106, extruded polymer tube 110, wire electrodes 112, and primary cuff 114. Solid wires 102 are connected to wire electrodes 112 at interconnection 108. Tube 110 transports gases to and from the lungs. Fitting 104 is configured to be connected to a respirating machine (not shown) for injecting air into the lungs and withdrawing air from the lungs. Cuff inflating conduit 106 is configured to be connected to a source of compressed air (not shown) for inflating cuff 114. Cuff inflating conduit 106 communicates with a lumen located in the wall of tube 110, and the lumen

communicates with primary cuff 114. After endotracheal tube 100 is inserted into the trachea of a patient, electrode wires 112 sense EMG signals, which are output to an EMG processing machine, such as nerve integrity monitor (NIM) device 120, via solid wires 102. Die cut tape may be used to tape tube 110 to a patient's mouth to secure the tube and keep it appropriately positioned.

[0048] In one embodiment, the NIM 120 is configured to determine when the electrodes 112 are in contact with the vocal folds, and is configured to provide an alert to the surgeon when such contact is lost. In one embodiment, the NIM 120 is also configured to determine whether the electrodes 112 are in contact with muscle or tissue based on the received signals. In one embodiment, EMG tube 100 is configured to wirelessly communicate with the NIM 120, and the NIM 120 is configured to wirelessly monitor the electrodes 112. In form of this embodiment, the NIM 120 wirelessly transmits energy to the electrodes 112, and the electrodes 112 wirelessly transmit EMG signals to the NIM 120.

[0049] Some existing endotracheal tubes can rotate, which causes the electrodes to move away from the vocal folds. In contrast, tube 110 includes a flexible tube segment 113 that is configured to make contact with the vocal folds, and exposed electrodes 112 are formed over the flexible tube segment 113. The flexible tube segment 113 is more flexible or softer (e.g., made from a low durometer material) than the remainder of the tube 110, which allows the electrodes 112 to maintain better opposition with the vocal folds and reduce or eliminate translational and rotational movement of the tube 110. In one embodiment, primary cuff 114 is formed from a tacky, low-durometer material to contour against the tracheal rings, which helps to reduce or eliminate translational and rotational movement of the tube 110. In one embodiment, electrodes 112 are about 1.3 inches long. In another embodiment, electrodes 112 are about 1.9 inches long. Extending the length of electrodes 112 helps the tube 110 to become less sensitive to neck extension.

[0050] In one embodiment, tube 110 is a braided tube that is more flexible than conventional solid polymer tubes, and that reduces kinking. Tube 110 according to one embodiment is formed from a braided polymer or nitinol within a thin-walled tube, and reduces or eliminates rotation of the tube at the vocal folds, while allowing a proximal portion of the tube to rotate.

[0051] FIG. 3 shows an EMG endotracheal tube 300 made from PVC. FIG. 4 shows a close-up view of a portion of the endotracheal tube 300 shown in FIG. 3. Endotracheal tube 300 includes solid wires 302, fitting 304, cuff inflating conduit 306, PVC tube 310, taped-on electrodes 312, primary cuff 314, and electrode wires 316. Solid wires 302 are connected to electrode wires 316 at interconnection 308, and electrode wires 316 are connected to taped-on electrodes 312. Tube 310 transports gases to and from the lungs. Fitting 304 is configured to be connected to a respirating machine (not shown) for injecting air into the lungs and withdrawing air from the lungs. Cuff inflating conduit 306 is configured to be connected to a source of compressed air (not shown) for inflating cuff 314. Cuff inflating conduit 306 communicates with a lumen located in the wall of tube 310, and the lumen communicates with primary cuff 314. After endotracheal tube 300 is inserted into the trachea of a patient,

taped-on electrodes **312** sense EMG signals, which are output to an EMG processing machine (e.g., NIM device **120**) via solid wires **302**.

[0052] FIG. 5 shows an EMG endotracheal tube **500** with conductive ink electrodes printed on the tube according to one embodiment. FIG. 6 shows a close-up view of a portion of the endotracheal tube **500** shown in FIG. 5 according to one embodiment. Endotracheal tube **500** includes solid wires **502**, fitting **504**, cuff inflating conduit **506**, PVC tube **510**, conductive ink electrodes **512**, and primary cuff **514**. Solid wires **502** are connected to conductive ink electrodes **512** at interconnection **508**. Tube **510** transports gases to and from the lungs. Fitting **504** is configured to be connected to a respirating machine (not shown) for injecting air into the lungs and withdrawing air from the lungs. Cuff inflating conduit **506** is configured to be connected to a source of compressed air (not shown) for inflating cuff **514**. Cuff inflating conduit **506** communicates with a lumen **522** (FIG. 7) located in the wall **520** of tube **510**, and the lumen **522** communicates with primary cuff **514**. After endotracheal tube **500** is inserted into the trachea of a patient, conductive ink electrodes **512** sense EMG signals, which are output to an EMG processing machine (e.g., NIM device **120**) via solid wires **502**.

[0053] FIG. 7 is a diagram illustrating a cross-sectional view of the endotracheal tube **500** shown in FIG. 5 according to one embodiment. As shown in FIG. 7, lumen **522** is located in the wall **520** of tube **510** for inflating the cuff **514**. Conductive ink electrodes **512** are formed on the outer surface of wall **520**. In one embodiment, conductive ink electrodes **512** are formed by tracing or printing a silver filled polymer conductive ink or a carbon conductive ink on tube **510**. Conductive inks are available in variety of flowable material choices such as Silver, Carbon, Gold, Platinum, Palladium, Silver-Tungsten, and Silver-Titanium. Conductive inks can be deposited on the substrate using various known technologies such as PAD printing, Screen printing, Ink jet dispensing, digital printing, Micropen dispensing, painting, vapor deposition, and plasma sputtering. Conductive inks can be used both for stimulation and recording purposes in nerve monitoring applications.

[0054] FIG. 8 shows an EMG endotracheal tube **800** with multiple pairs of conductive ink electrodes printed around the circumference of the tube according to one embodiment. FIG. 9 shows a close-up view of a portion of the endotracheal tube **800** shown in FIG. 8 according to one embodiment. Endotracheal tube **800** includes fitting **804**, cuff inflating conduit **806**, PVC tube **810**, conductive ink electrodes **812**, and primary cuff **814**. Tube **810** transports gases to and from the lungs. Fitting **804** is configured to be connected to a respirating machine (not shown) for injecting air into the lungs and withdrawing air from the lungs. Cuff inflating conduit **806** is configured to be connected to a source of compressed air (not shown) for inflating cuff **814**. Cuff inflating conduit **806** communicates with a lumen **822** (FIG. 10) located in the wall **820** of tube **810**, and the lumen **822** communicates with primary cuff **814**. After endotracheal tube **800** is inserted into the trachea of a patient, conductive ink electrodes **812** sense EMG signals, which are output to an EMG processing machine (e.g., NIM device **120**) via solid wires connected to the electrodes **812** (e.g., solid wires **502** shown in FIG. 5).

[0055] FIG. 10 is a diagram illustrating a cross-sectional view of the endotracheal tube **800** shown in FIG. 8 accord-

ing to one embodiment. As shown in FIG. 10, lumen **822** is located in the wall **820** of tube **810** for inflating the cuff **814**. Multiple pairs of conductive ink electrodes **812** are formed around the circumference of the tube **810** to achieve uninterrupted EMG recording even when the tube **810** is shifted rotationally. In one embodiment, conductive ink electrodes **812** are formed by tracing or printing a silver filled polymer conductive ink on tube **810**.

[0056] FIG. 11 shows an EMG endotracheal tube **1100** with a primary cuff **1114** and a secondary cuff **1130** according to one embodiment. FIG. 12A shows a close-up view of the secondary cuff **1130** of the endotracheal tube shown in FIG. 11 with conductive ink electrodes **1132** printed on the secondary cuff **1130** according to one embodiment. FIG. 12B shows a close-up view of the secondary cuff **1130** of the endotracheal tube shown in FIG. 11 according to another embodiment. The embodiment of the secondary cuff **1130** shown in FIG. 12A is identified by reference number **1130-1**, and the embodiment shown in FIG. 12B is identified by reference number **1130-2**. Endotracheal tube **1100** includes PVC tube **1110**, primary cuff **1114**, and secondary cuff **1130** with conductive ink electrodes **1132** formed thereon. Tube **1110** transports gases to and from the lungs. At least one cuff inflating conduit (not shown) is configured to be connected to a source of compressed air (not shown) for inflating cuffs **1114** and **1130**. After endotracheal tube **1100** is inserted into the trachea of a patient, the secondary cuff **1130** is inflated and the conductive ink electrodes **1132** come in contact with the vocal folds and sense EMG signals from the vocal folds. The sensed signals are output to an EMG processing machine (e.g., NIM device **120**) via wires connected to the electrodes **1132**. In one embodiment, the secondary cuff **1130** is made of a compliant or semi-compliant material, and conductive ink electrodes **1132** are formed by tracing or printing a silver filled polymer conductive ink on secondary cuff **1130**. The secondary cuff **1130** with the silver ink printed thereon helps establish a better electrode contact when inflated over the vocal folds. Electrodes **1132** may be sprayed on secondary cuff **1130** or tube **1110**, and may cover substantially the entire surface of secondary cuff **1130**. Electrodes **1132** may take a variety of shapes or forms other than that shown in FIG. 12A, such as any of the shapes or forms shown in any of the other Figures of the present disclosure, or other shapes. In other embodiments, EMG tube **1100** may include three or more cuffs.

[0057] Secondary cuff **1130** may also have a different shape than that shown in FIG. 12A, such as that shown in FIG. 12B. As shown in FIG. 12B, secondary cuff **1130-2** has a flattened peanut shape with two rounded ends **1133** and **1137** that taper to a mid portion **1135**. The flattened peanut shape of the cuff **1130-2** according to one embodiment fits or contours to the shape of the vocal folds, and helps to reduce or eliminate translational and rotational movement of the tube **1110**. In another embodiment, the secondary cuff **1130** is formed from an elastomer or foam pillow with two rounded ends that taper to a mid portion like that shown in FIG. 12B. In one form of this embodiment, the ends of the pillow have a substantially triangular cross-section. In one embodiment, the secondary cuff **1130** includes one or more position sensors to monitor the position or location of the tube **1110**.

[0058] FIG. 13 shows an EMG endotracheal tube **1300** with a visual indicator **1320** for tracking and verifying electrode location according to one embodiment. FIG. 14

shows a close-up view of a portion of the endotracheal tube **1300** shown in FIG. **13** according to one embodiment. Endotracheal tube **1300** includes solid wires **1302**, fitting **1304**, cuff inflating conduit **1306**, PVC tube **1310**, electrodes **1312**, primary cuff **1314**, and visual indicator **1320**. Solid wires **1302** are connected to electrodes **1312**. Tube **1310** transports gases to and from the lungs. Fitting **1304** is configured to be connected to a respirating machine (not shown) for injecting air into the lungs and withdrawing air from the lungs. Cuff inflating conduit **1306** is configured to be connected to a source of compressed air (not shown) for inflating cuff **1314**. Cuff inflating conduit **1306** communicates with a lumen located in the wall of tube **1310**, and the lumen communicates with primary cuff **1314**. After endotracheal tube **1300** is inserted into the trachea of a patient, electrodes **1312** sense EMG signals, which are output to an EMG processing machine (e.g., NIM device **120**) via solid wires **1302**.

[**0059**] In one embodiment, visual indicator **1320** is a bright lit light emitting diode (LED) or fiber optic light source that is used to track and verify the location of the electrodes **1312**. The visual indicator **1320** is placed on the surface of the tube **1310** near the electrodes **1312** to identify the electrode position with respect to the vocal fold after tube intubation. A user can see the light spot facing anterior and mark the spot on the patient's skin. In another embodiment, visual indicator **1320** is an LED band that surrounds a portion or the entire circumference of tube **1310**.

[**0060**] FIG. **15** shows an EMG endotracheal tube **1500** with a magnet indicator **1520** for tracking and verifying electrode location according to one embodiment. FIGS. **16** and **17** show close-up views of a portion of the endotracheal tube **1500** shown in FIG. **15** according to one embodiment. Endotracheal tube **1500** includes solid wires **1502**, cuff inflating conduit **1506**, tube **1510**, electrodes **1512**, primary cuff **1514**, and magnetic indicator **1520**. Solid wires **1502** are connected to electrodes **1512**. Tube **1510** transports gases to and from the lungs. A fitting of the tube **1500** is configured to be connected to a respirating machine (not shown) for injecting air into the lungs and withdrawing air from the lungs. Cuff inflating conduit **1506** is configured to be connected to a source of compressed air (not shown) for inflating cuff **1514**. Cuff inflating conduit **1506** communicates with a lumen located in the wall of tube **1510**, and the lumen communicates with primary cuff **1514**. After endotracheal tube **1500** is inserted into the trachea of a patient, electrodes **1512** sense EMG signals, which are output to an EMG processing machine (e.g., NIM device **120**) via solid wires **1502**.

[**0061**] In one embodiment, magnetic indicator **1520** is a tiny magnet that is used to track and verify the location of the electrodes **1512**. The magnetic indicator **1520** is placed on the surface of the tube **1510** near the electrodes **1512** to identify the electrode position with respect to the vocal fold after tube intubation. A user can track and locate the magnet inside the patient with a device **1530** (FIG. **17**) that includes a magnet pick-up sensor.

[**0062**] In addition to the LED-based and magnet-based techniques described above with respect to FIGS. **13-17**, other embodiments may use other techniques for determining electrode location within a patient, such as the following: (1) locating an anatomy landmark; (2) Automatic Periodic Stimulation (APS) electrode tracking; (3) sonar/ultra sound (similar to a wall stud finder); (4) surgical navigation using

a coil; (5) use of stimulator combined with locating device, and synchronizing the lighting of LED with the stimulator pulse of the wand; (6) use of an accelerometer (e.g., positioned on the cuff) to monitor movement; (7) use of a vibration sensor and air inlets and outlets so that air flow past the vocal folds causes vibration that is sensed by the vibration sensor; (8) use of an ultrasonic transducer in or on the tube, and a sensing circuit external to the body; (9) use of a resonant circuit for positional and rotational sensing (could use stimulator channel to provide pulses); use resonant vibration near vocal fold tissue resonance; mechanical impedance of the vocal fold is detected by impedance match and energy transfer to surrounding tissue; use surface acoustic wave or other mechanical resonator; (10) use of a pressure sensor or pressure sensor array near the electrode sites to detect engagement with the vocal folds (e.g., a pressure sensitive surface with capacitive sensor on each side of the tube); (11) wireless sensors linked to a wireless interface (e.g., the tube may include a wireless video chip to send signals to an external monitor (e.g., picture-in-picture on the NIM or miniscreen) to view placement in real time); (12) temperature sensors (temperature will be higher when in contact with the vocal folds); (13) embedded fiber optic viewer with light source at proximal end and viewing window near electrodes (software in NIM to identify position); (14) one or more RF ID tags incorporated in or on the tube with signals sent to an external device or the NIM for reading and evaluation; (15) flexible piezo strips for monitoring the movement of one or more portions of the tube, such as the flexible tube segment **113** (FIGS. **1** and **2**)—monitoring movement of the flexible tube segment **113** indirectly results in monitoring of the movement of the vocal folds; (16) impedance monitors placed around one or more portions of the tube, such as around tube segment **113** (FIGS. **1** and **2**), to detect changes in the diameter of the tube at the vocal folds (such impedance monitoring allows the vocal fold movement to be monitored without recording EMG potentials); and (17) use electrodes with the ability to differentiate between muscle contact and non-muscle contact, which helps the NIM to ensure proper position and contact.

[**0063**] FIG. **18** shows an EMG endotracheal tube **1800** with a coupling adapter **1820** to provide rotational freedom according to one embodiment. FIG. **19** shows a close-up view of a portion of the endotracheal tube **1800** shown in FIG. **18** according to one embodiment. Endotracheal tube **1800** includes solid wires **1802**, fitting **1804**, cuff inflating conduit **1806**, PVC tube **1810**, electrodes **1812**, primary cuff **1814**, and plastic coupling adapter **1820**. Solid wires **1802** are connected to electrodes **1812**. Tube **1810** transports gases to and from the lungs. Fitting **1804** is configured to be connected to a respirating machine (not shown) for injecting air into the lungs and withdrawing air from the lungs. Cuff inflating conduit **1806** is configured to be connected to a source of compressed air (not shown) for inflating cuff **1814**. Cuff inflating conduit **1806** communicates with a lumen located in the wall of tube **1810**, and the lumen communicates with primary cuff **1814**. After endotracheal tube **1800** is inserted into the trachea of a patient, electrodes **1812** sense EMG signals, which are output to an EMG processing machine (e.g., NIM device **120**) via solid wires **1802**.

[**0064**] In one embodiment, after insertion of the endotracheal tube **1800** into a patient, the tube is taped to the patient's mouth. The coupling adapter **1820** is positioned at

the proximal end (away from the patient's mouth), and allows the proximal end of the tube **1810** to swivel around as indicated by arrow **1830** in FIG. **19**, which minimizes rotational movement of the distal portion of the tube **1810** in the patient. In one embodiment, the coupling adapter **1820** allows thirty degrees of rotation in either direction. In another embodiment, endotracheal tube **1800** includes a tube within a tube configuration that allows a proximal portion of the tube to rotate while preventing rotation of the distal portion of the tube. In one embodiment, primary cuff **1814** is formed from a sticky or tacky material (e.g., a tacky balloon) to help prevent the distal portion of the tube from rotating.

[**0065**] FIG. **20** shows an EMG endotracheal tube **2000** with ribs **2020** on the top and bottom of the EMG electrodes **2012** according to one embodiment. FIG. **21** shows a close-up view of a portion of the endotracheal tube **2000** shown in FIG. **20** according to one embodiment. Endotracheal tube **2000** includes solid wires **2002**, fitting **2004**, cuff inflating conduit **2006**, tube **2010**, electrodes **2012**, primary cuff **2014**, and ribs **2020**. Solid wires **2002** are connected to electrodes **2012**. Tube **2010** transports gases to and from the lungs. Fitting **2004** is configured to be connected to a respirating machine (not shown) for injecting air into the lungs and withdrawing air from the lungs. Cuff inflating conduit **2006** is configured to be connected to a source of compressed air (not shown) for inflating cuff **2014**. Cuff inflating conduit **2006** communicates with a lumen located in the wall of tube **2010**, and the lumen communicates with primary cuff **2014**. After endotracheal tube **2000** is inserted into the trachea of a patient, electrodes **2012** sense EMG signals, which are output to an EMG processing machine (e.g., NIM device **120**) via solid wires **2002**.

[**0066**] The ribs **2020** according to one embodiment provide a positive feel when passing the vocal fold during intubation, and the ribs **2020** on top and bottom of the vocal fold will not allow the tube **2010** to move out of position. In one embodiment, the ribs **2020** are shaped to match the contour of the opening, and are made with compliant or semi-compliant material. In another embodiment, ribs **2020** are implemented with inflatable balloons.

[**0067**] FIG. **22** shows an EMG endotracheal tube **2200** with conductive tape on the surface of the tube for recording EMG signals according to one embodiment. FIG. **23** shows a close-up view of a portion of the endotracheal tube **2200** shown in FIG. **22** according to one embodiment. Endotracheal tube **2200** includes fitting **2204**, cuff inflating conduit **2206**, tube **2210**, electrodes **2212**, and primary cuff **2214**. Solid wires are connected to electrodes **2212**. Tube **2210** transports gases to and from the lungs. Fitting **2204** is configured to be connected to a respirating machine (not shown) for injecting air into the lungs and withdrawing air from the lungs. Cuff inflating conduit **2206** is configured to be connected to a source of compressed air (not shown) for inflating cuff **2214**. Cuff inflating conduit **2206** communicates with a lumen located in the wall of tube **2210**, and the lumen communicates with primary cuff **2214**. After endotracheal tube **2200** is inserted into the trachea of a patient, electrodes **2212** sense EMG signals, which are output to an EMG processing machine (e.g., NIM device **120**) via solid wires attached to the electrodes **2212**.

[**0068**] In the embodiment illustrated in FIGS. **22** and **23**, electrodes **2212** are strips of conducting tape that stick to the surface of the tube **2210**. In one embodiment, the conducting

tape is a woven material, and replaces the solid wire electrodes found in some conventional tubes (2 channel or multiple pairs). In one embodiment, one or more of the strips **2212** shown in FIGS. **22** and **23** comprise a piezo strip for monitoring movement of the tube **2210**. In another embodiment, electrodes **2212** are covered with an expandable, conductive foam that expands when it absorbs moisture, thereby providing improved contact with the vocal folds.

[**0069**] FIG. **24** shows an EMG endotracheal tube **2400** with a custom extruded PVC tube according to one embodiment. FIGS. **25** and **26** show close-up views of a portion of the endotracheal tube **2400** shown in FIG. **24** according to one embodiment. Endotracheal tube **2400** includes solid wires **2402**, fitting **2404**, cuff inflating conduit **2406**, tube **2410**, electrodes **2412**, and primary cuff **2414**. Solid wires **2402** are connected to electrodes **2412**. Tube **2410** transports gases to and from the lungs. Fitting **2404** is configured to be connected to a respirating machine (not shown) for injecting air into the lungs and withdrawing air from the lungs. Cuff inflating conduit **2406** is configured to be connected to a source of compressed air (not shown) for inflating cuff **2414**. Cuff inflating conduit **2406** communicates with a lumen located in the wall of tube **2410**, and the lumen communicates with primary cuff **2414**. After endotracheal tube **2400** is inserted into the trachea of a patient, electrodes **2412** sense EMG signals, which are output to an EMG processing machine (e.g., NIM device **120**) via solid wires **2402**.

[**0070**] In one embodiment, tube **2410** comprises a custom extruded PVC tube (rigid or reinforced), and the PVC cuff is not sticky like a silicone cuff. The size of the custom extruded PVC tube **2410** according to one embodiment is close to standard off-the-shelf endotracheal tubes.

[**0071**] Features of embodiments of the EMG endotracheal tubes described herein include: (1) more placement tolerant than conventional tubes; (2) NIM is used to help place the tube; (3) the electrode is periodically checked to assure constant contact; (4) intentional bend in correct direction for proper tube insertion; (5) include high brightness LED in tube to observe placement through the skin; (6) use external Hall sensors with magnets in the tube to sense correct tube placement; (7) kit-pack tapes for stabilizing the tube; (8) improved means to detect EMG generators and shunt tissue; (9) use muscle "artifact" as an indicator of proper placement (artifact can be minimized by adjusting tube position); (10) fiber optic bundle connected to light source or camera; (11) a "fixture" molded at the proximal end of the tube to register on the patient anatomy for proper orientation; (12) improved way and connector for plugging into the patient box; (13) creation of 4-channels from 2-channels via added connectors (not added wires) or cross-point switch within the NIM; (14) providing a signal from the NIM to measure resistance and phase angle of tissue contacting the electrodes to decide if there is enough EMG generator tissue vs. shunt tissue; (15) EMG tube with reduced overall outer diameter; and (16) reduced cost and quality associated issues with custom extruded silicone tubing by utilizing standard off the shelf endotracheal tube. Additional features and information are set forth below.

[**0072**] The EMG tube electrodes according to one embodiment may contact both EMG generators (striated muscle) and shunt tissue (conductive tissue that does not generate EMG signals but which does conduct current, thus shunting (reducing) the EMG signal available for the ampli-

fier). A “high quality tube placement” has a high ratio of EMG generator tissue to shunt tissue.

[0073] Embodiments of the EMG endotracheal tubes described herein may include a conducting hydro gel coating on the electrodes, such as electrodes 112 (FIG. 1). Coating the electrodes with a conducting hydro gel increases the contact surface of the electrodes, allows for more rotation of the EMG tube without a loss of contact with the vocal folds, and results in an improved recorded signal. Some embodiments may use paddle electrodes for posterior and anterior monitoring, including monitoring arytenoids and posterior cricoarytenoid (PCA).

[0074] There are some problems with existing EMG endotracheal, such as: (1) ridges on the outside of the tube can cause tissue irritation; (2) the tube can shift rotationally during surgery; and (3) the tube wall is too thick. These problems are addressed in one embodiment in the following ways: (1) use of a non-silicone material such as Pebax with Teflon for the tube, which allows the tube to slide easily (a high friction material may be used for the cuff to help prevent translational shift); (2) placing bumps for wires on the inner diameter (ID) of the tube; (3) splicing together different pieces of tubing along the length (each with potentially a different cross-sectional shape) to get a more optimal cross-sectional geometry that more closely matches a patient’s anatomy, such as using a first tube portion near the proximal end with a circular cross-section to allow rotation and a second tube portion near the vocal folds with a triangular cross-section (e.g., with a circular or triangular inner diameter); (4) just above the electrodes, adding a region of lower wall thickness to de-couple upper sections from lower section; and (5) decoupling the proximal end of the tube from the distal end by switching to a braided tube from a spring coil reinforced tube.

[0075] FIG. 27 shows an EMG endotracheal tube 2700 positioned within a patient’s throat according to one embodiment. Endotracheal tube 2700 includes fitting 2704, tube 2710, electrodes 2712, primary cuff 2714, esophageal extension 2720, and esophageal electrodes 2722. The portions of the patient’s anatomy shown in FIG. 27 include tongue 2730, trachea 2732, and esophagus 2734. Tube 2710 transports gases to and from the lungs. Fitting 2704 is configured to be connected to a respirating machine (not shown) for injecting air into the lungs and withdrawing air from the lungs. A cuff inflating conduit is configured to be connected to a source of compressed air for inflating cuff 2714. After endotracheal tube 2700 is inserted into the trachea 2732 of the patient, electrodes 2712 sense EMG signals, which are output to an EMG processing machine (e.g., NIM device 120) via solid wires connected to electrodes 2712.

[0076] As shown in FIG. 27, esophageal extension 2720 extends away from the tube 2710 and into the patient’s esophagus 2734. The esophageal electrodes 2722 formed on the extension 2720 sense signals from the backside muscles of the vocal folds from the esophagus 2734. The electrodes 2722 according to one embodiment are used to record EMG signals of laryngeal muscles behind the larynx. In one embodiment, the electrodes 2722 are positioned behind the cricoid cartilage during surgery. Most of the muscles innervated by the recurrent laryngeal nerve (RLN) are behind and posterolateral to the larynx (e.g., arytenoids, posterior cricoarytenoid (PCA), and lateral cricoarytenoid (LCA)). Positioning the electrodes 2722 behind the cricoid cartilage

provides superior EMG signals. In one embodiment, esophageal extension 2720 is also used to set both the depth of insertion of the tube 2710 and the angular placement.

[0077] FIG. 28A shows an EMG endotracheal tube 2800A with electrodes having an increased surface area according to one embodiment. Tube 2800A includes electrode 2802A, which has a sinusoidal wave shape that extends around the circumference of the tube 2800A with peaks and valleys that extend in a longitudinal direction of the tube 2800A.

[0078] FIG. 28B shows an EMG endotracheal tube 2800B with electrodes having an increased surface area according to another embodiment. Tube 2800B includes electrodes 2802B, which are formed around a circumference of the tube 2800B and extend in a longitudinal direction of the tube 2800B. Electrodes 2802B include a first set of electrodes 2802B-1 that are interleaved with and longitudinally displaced from a second set of electrodes 2802B-2. The electrodes 2802B-1 are positioned closer to a proximal end of the tube 2800B than electrodes 2802B-2, and the electrodes 2802B-2 are positioned closer to a distal end of the tube 2800B than electrodes 2802B-1.

[0079] FIG. 28C shows an EMG endotracheal tube 2800C with electrodes having an increased surface area according to another embodiment. Tube 2800C includes electrodes 2802C-1 and 2802C-2, which each have a sinusoidal wave shape that extends along a portion of the length of the tube 2800C, with peaks and valleys that extend in a lateral direction of the tube 2800C.

[0080] FIG. 28D shows an EMG endotracheal tube 2800D with electrodes having an increased surface area according to another embodiment. Tube 2800D includes electrode array 2802D, which includes a plurality of horizontal electrodes 2802D-1 and 2802D-2 and a plurality of vertical electrodes 2802D-3 and 2802D-4 that form a grid pattern. Horizontal electrodes 2802D-1 and 2802D-2 extend laterally around a circumference of the tube 2800D, and vertical electrodes 2802D-3 and 2802D-4 extend longitudinally along a portion of the length of the tube 2800D.

[0081] The electrode configurations shown in FIGS. 28A-28D help to reduce or eliminate rotational sensitivity of the tube. In one embodiment, the shape of the electrodes conforms to the vocal folds to avoid shunting problems.

[0082] FIG. 29 shows an EMG endotracheal tube 2900 with an overall shape that is curved to match the shape of a human throat according to one embodiment. Endotracheal tube 2900 includes fitting 2904, tube 2910, electrodes 2912, and primary cuff 2914. Tube 2910 transports gases to and from the lungs. Fitting 2904 is configured to be connected to a respirating machine (not shown) for injecting air into the lungs and withdrawing air from the lungs. A cuff inflating conduit is configured to be connected to a source of compressed air for inflating cuff 2914. After endotracheal tube 2900 is inserted into the trachea of the patient, electrodes 2912 sense EMG signals, which are output to an EMG processing machine (e.g., NIM device 120) via solid wires connected to electrodes 2912.

[0083] As shown in FIG. 29, tube 2910 is not a straight tube, but rather is bent or curved in at least one location along the length of the tube 2910, such that the tube 2910 has a natural shape that matches or substantially matches the shape of a human throat. The curved shape of the tube 2910 provides tactual feel for proper placement in a patient.

[0084] FIG. 30 shows a cross-sectional view of an EMG endotracheal tube 3000 with electrodes configured to reduce

or eliminate rotational sensitivity according to one embodiment. Four electrodes **3002A-3002D** are positioned on tube **3004** and extend longitudinally along a portion of the length of the tube **3004** (i.e., into and out of the paper in FIG. **30**). In the illustrated embodiment, the four electrodes **3002A-3002D** are spaced equally apart along the circumference of the tube **3004**. Electrode **3002A** corresponds to channel 1+ and channel 3+. Electrode **3002B** corresponds to channel 2+ and channel 4-. Electrode **3002C** corresponds to channel 1- and channel 4+. Electrode **3002D** corresponds to channel 2- and channel 3-.

[0085] As shown in FIG. **30**, a four-electrode tube can be used to create four channels by using the diagonal pairs of electrodes for channels 3 and 4. This electrode configuration helps ensure that the tube will always have two good monitoring channels regardless of rotation, and thereby helps reduce or eliminate rotational sensitivity of the tube. A four-electrode tube can also be used to create six channels (e.g., by using the top two electrodes for channel 5 and the bottom two electrodes for channel 6). In one embodiment, the NIM **120** (FIG. **1**) is configured to display all four or six channels. In another embodiment, the NIM **120** is configured to determine which of the four or six channels are providing the best signal, and display only the best channel or channels. In one embodiment, tube **3004** includes an identification component (e.g., resistor, RF, magnet, digital) that causes the NIM **120** to switch into a multi-channel mode. The tube may also include one or more LEDs to verify the depth of insertion of the tube. Rotational sensitivity may also be reduced or eliminated by multiplexing a large number of electrode pairs.

[0086] FIG. **31** shows an EMG endotracheal tube **3100** with electrodes configured to reduce or eliminate rotational sensitivity according to another embodiment. EMG endotracheal tube **3100** includes tube **3110**, primary cuff **3114**, and electrode carriers **3120A** and **3120B**. Each of the electrode carriers **3120A** and **3120B** is donut-shaped, and surrounds the circumference of the tube **3110**. The electrode carriers **3120A** and **3120B** are spaced apart from each other along the length of the tube **3110**. Electrode **3112A** is formed on electrode carrier **3120A**, and electrode **3112B** is formed on electrode carrier **3120B**. Each of the electrodes **3112A** and **3112B** has a sinusoidal wave shape that extends around the circumference of the respective carrier **3120A** and **3120B**, with peaks and valleys that extend in a longitudinal direction of the tube **3110**. In one embodiment, electrode **3112A** is a negative electrode and electrode **3112B** is a positive electrode. The electrode configuration shown in FIG. **31** helps to reduce or eliminate rotational sensitivity of EMG endotracheal tube **3100**.

[0087] In another embodiment, EMG endotracheal tube **3100** includes only a single donut-shaped electrode carrier **3120A**, and the carrier **3120A** is slidably coupled to the tube **3110** to allow the carrier **3120A** to longitudinally slide up and down along the length of the tube **3110**. In one form of this embodiment, a control member may be attached to the carrier **3120A** to selectively cause the carrier **3120A** to expand and allow sliding, or to contract and prevent sliding. For example, the control member may cause the carrier **3120A** to expand when the carrier **3120A** is positioned at the vocal folds such that the carrier **3120A** stays at that location while the tube **3110** is allowed to slide through the carrier **3120A**. In one embodiment, one or both of the carriers

3120A and **3120B** may have a circular cross-sectional shape, or a non-circular cross-sectional shape (e.g., triangular shape).

[0088] FIG. **32** shows a cuff **3200** for an EMG endotracheal tube according to one embodiment. Cuff **3200** includes an expandable cuff portion **3202** and tension members **3204**. Cuff **3200** also includes a cylindrically-shaped opening **3206** that extends through the cuff **3200**, and allows the cuff **3200** to be slid onto an endotracheal tube. Tension members **3204** allow expansion of the cuff portion **3202**, but resist torsion and help to minimize rotation of cuff **3200** and the endotracheal tube. In one embodiment, tension members **3204** are self-expanding and are formed from a shape memory material, such as nitinol. In one embodiment, tension members **3204** are a nitinol framework or basket, and the cuff **3200** includes electrodes formed thereon. In one form of this embodiment, the cuff **3200** is configured to atraumatically conform to the shape of the vocal folds.

[0089] FIG. **33** shows an electrical schematic diagram of an electrode array configured to be used in an EMG endotracheal tube according to one embodiment. The electrode array includes five electrodes **3302** in a star configuration, with the electrodes **3302** sharing a common node **3304**. Positive terminal **3306** is connected to the common node **3304**. The array also includes terminal **3308**. In one embodiment, terminal **3306** and electrodes **3302** are located on the tube, and terminal **3308** is located on a primary or secondary cuff of the tube. The electrode configuration shown in FIG. **33** helps to reduce or eliminate rotational sensitivity of the EMG endotracheal tube. Rotational sensitivity may also be reduced or eliminated by using two ring electrodes that surround the circumference of the tube at two locations (e.g., one ring electrode at the vocal folds and a second ring electrode on a primary or secondary cuff of the tube).

[0090] FIG. **34** shows flexible, expanding electrodes configured to be used in an EMG endotracheal tube according to one embodiment. As shown in FIG. **34**, a pair of spaced-apart retaining rings **3422** and **3424** each surround the circumference of tube **3410**. The rings **3422** and **3424** hold flexible electrodes **3412** in place between the rings. The electrodes **3412** extend longitudinally along a portion of the length of tube **3410**. The closer that rings **3422** and **3424** are positioned toward each other along tube **3410**, the farther that the electrodes **3412** extend away from tube **3410**. The farther that rings **3422** are positioned away from each other along tube **3410**, the closer that the electrodes **3412** are to the tube **3410**. The electrodes **3412** may be used to mechanically stimulate the vocal chords. The vocal folds will push the flexible electrodes **3412** inward toward tube **3410**.

[0091] In the event of movement of an EMG endotracheal tube during surgery, the EMG electrodes on the tube may lose contact with the target muscle and may fail to provide the optimal EMG response. One embodiment provides an EMG endotracheal tube that is insensitive or substantially insensitive to tube movement (rotational and vertical), and provides uninterrupted EMG recording even if the tube moves rotationally or vertically inside the patient during surgery. One form of this embodiment is a tube with three electrodes, with two electrodes configured to be positioned above the vocal folds and one electrode configured to be positioned below the vocal folds. Another form of this embodiment is a tube with four electrodes, with two electrodes configured to be positioned above the vocal folds and two electrodes configured to be positioned below the vocal

folds, with the electrodes arranged equally angularly. The electrode configuration for these embodiments differs above and below the level of the vocal folds, which maximizes the signal difference between the activated muscle group and the inactive region. The electrodes above and below the level of the vocal folds improve monitoring of electromyographic (EMG) signals from the muscles of the larynx innervated by the recurrent laryngeal nerves (or the non-recurrent laryngeal nerves) and external branch of the superior laryngeal nerves. The electrodes above and below the level of the vocal folds provide posterior, lateral, and anterior monitoring of the larynx, for example; monitoring left and the right Vocalis muscle, Arytenoids, Thyroarytenoids, Posterior Cricoarytenoids, Lateral Cricoarytenoid, and Cricothyroid muscles. Embodiments that are substantially insensitive to tube position are described in further detail below with reference to FIGS. 35-37.

[0092] FIG. 35A shows a first side view (posterior side) of an EMG endotracheal tube 3500 with three electrodes according to one embodiment. FIG. 35B shows a second side view (rotated 90 degrees from the view shown in FIG. 35A) of the EMG endotracheal tube 3500 shown in FIG. 35A according to one embodiment. FIG. 35C is a diagram illustrating a cross-sectional view of the endotracheal tube 3500 shown in FIGS. 35A and 35B according to one embodiment. As shown in FIGS. 35A-35C, endotracheal tube 3500 includes tube 3510, electrodes 3512, and primary cuff 3514. Tube 3510 transports gases to and from the lungs. A proximal end (left end in FIG. 35A) of tube 3510 is configured to be connected to a respirating machine (not shown) for injecting air into the lungs and withdrawing air from the lungs. A cuff inflating conduit (not shown) is configured to be connected to a source of compressed air (not shown) for inflating cuff 3514. After endotracheal tube 3500 is inserted into the trachea of a patient, electrodes 3512 sense EMG signals, which are output to an EMG processing machine (e.g., NIM device 120).

[0093] Electrodes 3512 include three electrodes 3512A-3512C, which are formed around a circumference of the tube 3510 and extend in a longitudinal direction of the tube 3510. Electrode 3512B is positioned entirely on the posterior side of the tube 3510 and is also referred to herein as posterior electrode 3512B. Electrodes 3512A and 3512C are positioned primarily on the anterior side of the tube 3510 and are also referred to as anterior electrodes 3512A and 3512C. The anterior side of the tube 3510 is the bottom half of the tube 3510 shown in FIG. 35C, and the posterior side of the tube 3510 is the top half of the tube 3510 shown in FIG. 35C. Each of the electrodes 3512A-3512C is coupled to a respective trace 3524A-3524C (trace 3524A is not visible in the Figures). Traces 3524A-3524C are positioned in a protected (masked) region 3528 of tube 3510. Posterior electrode 3512B is positioned in an exposed (unmasked) region 3526A of tube 3510. Anterior electrodes 3512A and 3512C are positioned in an exposed (unmasked) region 3526B of tube 3510.

[0094] In one embodiment, each of the electrodes 3512A-3512C has a length of about one inch, and extends laterally around a circumference of the tube for a distance corresponding to an angle 3522 of about 90 degrees (i.e., each of the electrodes 3512A-3512C has a width of about 25 percent of the total circumference of the tube). The electrodes 3512A-3512C are laterally spaced apart around the circumference of the tube by a distance corresponding to an angle

3520 of about 30 degrees (i.e., the lateral spacing between each of the electrodes 3512A-3512C is about 8.333 percent of the total circumference of the tube). In another embodiment, each of the electrodes 3512A-3512C extends laterally around a circumference of the tube for a distance corresponding to an angle 3522 of about 60 degrees, and the electrodes 3512A-3512C are laterally spaced apart around the circumference of the tube by a distance corresponding to an angle 3520 of about 60 degrees. In yet another embodiment, the electrodes 3512A-3512C are laterally spaced apart around the circumference of the tube by a distance corresponding to an angle 3520 of greater than about 15 degrees. In one embodiment, the distance around the circumference of the tube from the center of one of the electrodes 3512A-3512C to the center of an adjacent electrode is about 110 degrees to 220 degrees. The posterior electrode 3512B is laterally positioned between the two anterior electrodes 3512A and 3512C, and is longitudinally offset or displaced from the anterior electrodes 3512A and 3512B. The posterior electrode 3512B is positioned closer to the distal end (right side in FIGS. 35A and 35B) of the tube 3510 than the anterior electrodes 3512A and 3512C, and the anterior electrodes 3512A and 3512C are positioned closer to the proximal end (left side in FIGS. 35A and 35B) of the tube 3510 than the posterior electrode 3512B.

[0095] Tube 3510 includes an overlap region 3530 where a proximal portion of the posterior electrode 3512B longitudinally overlaps with a distal portion of the anterior electrodes 3512A and 3512C. The electrodes 3512 do not physically overlap each other since they are laterally offset from each other. In one embodiment, the overlap region 3530 is about 0.1 inches long, and the overall length from a proximal end of the anterior electrodes 3512A and 3512C to a distal end of the posterior electrode 3512B is about 1.9 inches. In another embodiment, the overlap region 3530 is about 0.2 inches long, and the overall length from a proximal end of the anterior electrodes 3512A and 3512C to a distal end of the posterior electrode 3512B is about 1.8 inches. Tube 3510 is configured to be positioned such that the vocal folds of a patient are positioned in the overlap region 3530. Thus, the configuration of the electrodes 3512 above the vocal folds is different than the configuration below the vocal folds. The single posterior electrode 3512B is configured to be positioned primarily below the vocal folds, and the two anterior electrodes 3512A and 3512C are configured to be positioned primarily above the vocal folds. It has been determined that the largest response is provided on the anterior side at about 0.5 inches above the vocal folds. In one embodiment, electrodes 3512A and 3512B are used for a first EMG channel, and electrodes 3512C and 3512B are used for a second EMG channel.

[0096] FIG. 36A shows a first side view (posterior side) of an EMG endotracheal tube 3600 with four electrodes according to one embodiment. FIG. 36B shows a second side view (rotated 90 degrees from the view shown in FIG. 36A) of the EMG endotracheal tube 3600 shown in FIG. 36A according to one embodiment. FIG. 36C is a diagram illustrating a cross-sectional view of the endotracheal tube 3600 shown in FIGS. 36A and 36B according to one embodiment. As shown in FIGS. 36A-36C, endotracheal tube 3600 includes tube 3610, electrodes 3612, and primary cuff 3614. Tube 3610 transports gases to and from the lungs. A proximal end (left end in FIG. 36A) of tube 3610 is configured to be connected to a respirating machine (not

shown) for injecting air into the lungs and withdrawing air from the lungs. A cuff inflating conduit (not shown) is configured to be connected to a source of compressed air (not shown) for inflating cuff 3614. After endotracheal tube 3600 is inserted into the trachea of a patient, electrodes 3612 sense EMG signals, which are output to an EMG processing machine (e.g., NIM device 120).

[0097] Electrodes 3612 include four electrodes 3612A-3612D, which are formed around a circumference of the tube 3610 and extend in a longitudinal direction of the tube 3610. Electrodes 3612A and 3612B are positioned entirely on the posterior side of the tube 3610 and are also referred to herein as posterior electrodes 3612A and 3612B. Electrodes 3612C and 3612D are positioned entirely on the anterior side of the tube 3610 and are also referred to as anterior electrodes 3612C and 3612D. The anterior side of the tube 3610 is the bottom half of the tube 3610 shown in FIG. 36C, and the posterior side of the tube 3610 is the top half of the tube 3610 shown in FIG. 36C. Each of the electrodes 3612A-3612D is coupled to a respective trace 3624A-3624D (trace 3624D is not visible in the Figures). Traces 3624A-3624D are positioned in a protected (masked) region 3628 of tube 3610. Posterior electrodes 3612A and 3612B are positioned in an exposed (unmasked) region 3626A of tube 3610. Anterior electrodes 3612C and 3612D are positioned in an exposed (unmasked) region 3626B of tube 3610.

[0098] In one embodiment, each of the electrodes 3612A-3612D has a length of about one inch, and extends laterally around a circumference of the tube for a distance corresponding to an angle 3622 of about 60 degrees (i.e., each of the electrodes 3612A-3612D has a width of about 16.666 percent of the total circumference of the tube). The electrodes are laterally spaced apart around the circumference of the tube by a distance corresponding to an angle 3620 of about 30 degrees (i.e., the lateral spacing between each of the electrodes 3612A-3612D is about 8.333 percent of the total circumference of the tube). The posterior electrodes 3612A and 3612B are longitudinally offset or displaced from the anterior electrodes 3612C and 3612D. The posterior electrodes 3612A and 3612B are positioned closer to the distal end (right side in FIGS. 36A and 36B) of the tube 3610 than the anterior electrodes 3612C and 3612D, and the anterior electrodes 3612C and 3612D are positioned closer to the proximal end (left side in FIGS. 36A and 36B) of the tube 3610 than the posterior electrodes 3612A and 3612B.

[0099] Tube 3610 includes an overlap region 3630 where a proximal portion of the posterior electrodes 3612A and 3612B longitudinally overlap with a distal portion of the anterior electrodes 3612C and 3612D. The electrodes 3612 do not physically overlap each other since they are laterally offset from each other. In one embodiment, the overlap region 3630 is about 0.1 inches long, and the overall length from a proximal end of the anterior electrodes 3612C and 3612D to a distal end of the posterior electrodes 3612A and 3612B is about 1.9 inches. In another embodiment, the overlap region 3630 is about 0.2 inches long, and the overall length from a proximal end of the anterior electrodes 3612C and 3612D to a distal end of the posterior electrodes 3612A and 3612B is about 1.8 inches. Tube 3610 is configured to be positioned such that the vocal folds of a patient are positioned in the overlap region 3630. Thus, the configuration of the electrodes 3612 above the vocal folds is different than the configuration below the vocal folds. The posterior

electrodes 3612A and 3612B are configured to be positioned primarily below the vocal folds, and the anterior electrodes 3612C and 3612D are configured to be positioned primarily above the vocal folds. In one embodiment, electrodes 3612A and 3612C are used for a first EMG channel, and electrodes 3612B and 3612D are used for a second EMG channel. In another embodiment, electrodes 3612A and 3612D are used for a first EMG channel, and electrodes 3612B and 3612C are used for a second EMG channel.

[0100] FIG. 37A shows a first side view (posterior side) of an EMG endotracheal tube 3700 with four electrodes according to another embodiment. FIG. 37B shows a second side view (rotated 90 degrees from the view shown in FIG. 37A) of the EMG endotracheal tube 3700 shown in FIG. 37A according to one embodiment. As shown in FIGS. 37A and 36B, endotracheal tube 3700 includes tube 3710, electrodes 3712, and primary cuff 3714. Tube 3710 transports gases to and from the lungs. A proximal end (left end in FIG. 37A) of tube 3710 is configured to be connected to a respirating machine (not shown) for injecting air into the lungs and withdrawing air from the lungs. A cuff inflating conduit (not shown) is configured to be connected to a source of compressed air (not shown) for inflating cuff 3714. After endotracheal tube 3700 is inserted into the trachea of a patient, electrodes 3712 sense EMG signals, which are output to an EMG processing machine (e.g., NIM device 120).

[0101] Electrodes 3712 include four electrodes 3712A-3712D, which are formed around a circumference of the tube 3710 and extend in a longitudinal direction of the tube 3710. Each of the electrodes 3712A-3712D is coupled to a respective trace 3724A-3724D (traces 3724A and 3724D are not visible in the Figures). Traces 3724A-3724D are positioned in a protected (masked) region 3728 of tube 3710. Electrodes 3712C and 3712D are positioned in an exposed (unmasked) region 3726A of tube 3710. Electrodes 3712A and 3712B are positioned in an exposed (unmasked) region 3726B of tube 3710.

[0102] In one embodiment, each of the electrodes 3712A-3712D has a length of about one inch. In one embodiment, each of the electrodes 3712A and 3712B extends laterally around a circumference of the tube for a distance corresponding to an angle of about 140 degrees (i.e., each of the electrodes 3712A and 3712B has a width of about 38.888 percent of the total circumference of the tube). In one embodiment, each of the electrodes 3712C and 3712D extends laterally around a circumference of the tube for a distance corresponding to an angle of about 110 degrees (i.e., each of the electrodes 3712C and 3712D has a width of about 30.555 percent of the total circumference of the tube). Electrodes 3712A and 3712B are laterally spaced apart from each other around the circumference of the tube by a distance corresponding to an angle of about 40 degrees (i.e., the lateral spacing between the electrodes 3712A and 3712B is about 11.111 percent of the total circumference of the tube). Electrodes 3712C and 3712D are laterally spaced apart from each other around the circumference of the tube by a distance corresponding to an angle of about 70 degrees (i.e., the lateral spacing between the electrodes 3712C and 3712D is about 19.444 percent of the total circumference of the tube). The electrodes 3712A and 3712B are longitudinally offset or displaced from the electrodes 3712C and 3712D. The electrodes 3712C and 3712D are positioned closer to the distal end (right side in FIGS. 37A and 37B) of

the tube 3710 than the electrodes 3712A and 3712B, and the electrodes 3712A and 3712B are positioned closer to the proximal end (left side in FIGS. 37A and 37B) of the tube 3710 than the electrodes 3712C and 3712D.

[0103] Tube 3710 includes a separation region 3730 where a proximal end of the electrodes 3712C and 3712D is longitudinally separated from a distal end of the electrodes 3712A and 3712B. In one embodiment, the separation region 3730 is about 0.1 inches long, and the overall length from a proximal end of the electrodes 3712A and 3712B to a distal end of the electrodes 3712C and 3712D is about 2.1 inches. In another embodiment, the separation region 3730 is about 0.2 inches long, and the overall length from a proximal end of the electrodes 3712A and 3712B to a distal end of the electrodes 3712C and 3712D is about 2.2 inches. Tube 3710 is configured to be positioned such that the vocal folds of a patient are positioned in the separation region 3730. Thus, the configuration of the electrodes 3712 above the vocal folds is different than the configuration below the vocal folds. The electrodes 3712C and 3712D are configured to be positioned primarily below the vocal folds, and the electrodes 3712A and 3712B are configured to be positioned primarily above the vocal folds.

[0104] FIG. 38 shows a side view of an EMG endotracheal tube 3800 with a plurality of ring electrodes according to one embodiment. As shown in FIG. 38, endotracheal tube 3800 includes tube 3810, electrodes 3812, and primary cuff 3814. Tube 3810 transports gases to and from the lungs. A proximal end (left end in FIG. 38) of tube 3810 is configured to be connected to a respirating machine (not shown) for injecting air into the lungs and withdrawing air from the lungs. A cuff inflating conduit (not shown) is configured to be connected to a source of compressed air (not shown) for inflating cuff 3814. After endotracheal tube 3800 is inserted into the trachea of a patient, electrodes 3812 sense EMG signals, which are output to an EMG processing machine (e.g., NIM device 120).

[0105] Electrodes 3812 include a plurality of ring electrodes 3812A. In one embodiment, each of the ring electrodes 3812A completely surrounds a circumference of the tube 3810. In one embodiment, electrodes 3812 include sixteen ring electrodes 3812A that are longitudinally separated from each other along the length of the tube by a distance of about 0.05 inches, and have an overall length in the longitudinal direction of the tube of about 1.55 inches.

[0106] FIGS. 39A-39E show EMG endotracheal tubes with tube placement markings according to various embodiments. In one embodiment, the tube markings shown in FIGS. 39A-39E are formed from a radio opaque material.

[0107] As shown in FIG. 39A, EMG endotracheal tube 3900A includes three bands 3902, 3904, and 3906, and a vertical line segment 3908. The bands 3902, 3904, and 3906, and the vertical line segment 3908, are positioned on an electrode region of the tube 3900A, and facilitate proper longitudinal and rotational positioning of the electrodes of tube 3900A with respect to a patient's anatomy. Bands 3902, 3904, and 3906 are positioned adjacent to each other, with band 3904 positioned between band 3902 and 3906. In one embodiment, each of the bands 3902, 3904, and 3906 surrounds a circumference of the tube 3900A or a portion of the circumference of the tube 3900A, and the bands 3902, 3904, and 3906 have an overall length along a longitudinal axis of the tube 3900A that is the same or substantially the same as the length of the electrodes of tube 3900A. In one

embodiment, bands 3902 and 3906 have substantially the same length, which is about twice as long as the length of band 3904. Bands 3902, 3904, and 3906 are solid color bands in one embodiment, and at least two different colors are used for the three bands. In one embodiment, bands 3902, 3904, and 3906 are each a solid color band with a different color than the other bands (i.e., 3 different solid colors are used for the three bands). In one form of this embodiment, band 3902 is a green band, band 3904 is a white band, and band 3906 is a blue band. The colors are selected in one embodiment to differentiate the bands from blood and surrounding tissue. Vertical line segment 3908 extends in a longitudinal direction along tube 3900A, and has a length that is the same or substantially the same as the overall length of the bands 3902, 3904, and 3906.

[0108] As shown in FIG. 39B, EMG endotracheal tube 3900B includes band 3910, vertical line segment 3914, and horizontal line segments 3916, 3918, and 3920. The band 3910 and the line segments 3914, 3916, 3918, and 3920 are positioned on an electrode region of the tube 3900B, and facilitate proper longitudinal and rotational positioning of the electrodes of tube 3900B with respect to a patient's anatomy. In one embodiment, band 3910 surrounds a circumference of the tube 3900B, and has a length along a longitudinal axis of the tube 3900B that is the same or substantially the same as the length of the electrodes of tube 3900B. Band 3910 is a solid color band in one embodiment. In one embodiment, band 3910 is a white band. In another embodiment, band 3910 is a blue band. The color is selected in one embodiment to differentiate the band from blood and surrounding tissue.

[0109] Vertical line segment 3914 extends in a longitudinal direction along tube 3900B, and has a length that is the same or substantially the same as the length of the band 3910. Each of the horizontal line segments 3916, 3918, and 3920 intersects the vertical line segment 3914 and extends in a lateral direction around a portion of the circumference of the tube 3900B. The horizontal line segments 3916, 3918, and 3920 are each centered on the vertical line segment 3914, and are spaced apart from each other along a longitudinal axis of the tube 3900B. Horizontal line segment 3918 is positioned between segments 3916 and 3920. Horizontal line segments 3916 and 3920 have the same length in one embodiment, which is less than the length of segment 3918. In one embodiment, segment 3918 has a length that is at least about twice as long as the length of each of the segments 3916 and 3920.

[0110] As shown in FIG. 39C, EMG endotracheal tube 3900C includes band 3922, vertical line segment 3926, horizontal line segment 3928, and diagonal line segments 3930 and 3932. The band 3922 and the line segments 3926, 3928, 3930, and 3932 are positioned on an electrode region of the tube 3900C, and facilitate proper longitudinal and rotational positioning of the electrodes of tube 3900C with respect to a patient's anatomy. In one embodiment, band 3922 surrounds a circumference of the tube 3900C, and has a length along a longitudinal axis of the tube 3900C that is the same or substantially the same as the length of the electrodes of tube 3900C. Band 3922 is a solid color band in one embodiment. In one embodiment, band 3922 is a white band. In another embodiment, band 3922 is a blue band. The color is selected in one embodiment to differentiate the band from blood and surrounding tissue.

[0111] The line segments **3926**, **3928**, **3930**, and **3932** all intersect at a common point **3924**. Vertical line segment **3926** extends in a longitudinal direction along tube **3900C**, and has a length that is the same or substantially the same as the length of the band **3922**. The horizontal line segment **3928** is centered on the vertical line segment **3926** and extends in a lateral direction around a portion of the circumference of the tube **3900C**. Diagonal line segments **3930** and **3932** extend longitudinally and laterally along tube **3900C** and intersect each other at common point **3924** to form an x-type marking.

[0112] As shown in FIG. **39D**, EMG endotracheal tube **3900D** includes band **3934**, triangular markings **3936** and **3940**, and vertical line segment **3942**, which are positioned on an electrode region of the tube **3900D**, and facilitate proper longitudinal and rotational positioning of the electrodes of tube **3900D** with respect to a patient's anatomy. In one embodiment, band **3934** surrounds a circumference of the tube **3900D**, and has a length along a longitudinal axis of the tube **3900D** that is the same or substantially the same as the length of the electrodes of tube **3900D**. Band **3934** is a solid color band in one embodiment. In one embodiment, band **3934** is a white band.

[0113] Each of the triangular markings **3936** and **3940** according to one embodiment has substantially the shape of an isosceles triangle. Each of the triangular markings **3936** and **3940** has a base segment that extends laterally around a portion of the circumference of the tube **3900D**, and two equal sides that extend away from the base portion and meet at an apex of the triangle. The apexes of the triangular markings **3936** and **3940** share a common point **3938**. Each of the triangular markings **3936** and **3940** is a solid color marking in one embodiment. In one embodiment, the color of marking **3936** is different than the color of marking **3940**. In one form of this embodiment, marking **3936** is a green marking, and marking **3940** is a blue marking. The colors are selected in one embodiment to differentiate the markings from blood and surrounding tissue.

[0114] Vertical line segment **3942** extends in a longitudinal direction along tube **3900D** from the middle of the base segment of the triangular marking **3936** to the middle of the base segment of the triangular marking **3936**, and intersects the common point **3938**. Vertical line segment **3942** has a length that is the same or substantially the same as the length of the band **3934**.

[0115] As shown in FIG. **39E**, EMG endotracheal tube **3900E** includes band **3950**, vertical line or strip **3952**, and horizontal line or strip **3954**, which are positioned on an electrode region of the tube **3900E**, and facilitate proper longitudinal and rotational positioning of the electrodes of tube **3900E** with respect to a patient's anatomy. In one embodiment, band **3950** surrounds a circumference of the tube **3900E**. Band **3950** is a solid color band in one embodiment.

[0116] Vertical strip **3952** extends in a longitudinal direction along tube **3900E**, and has a length that is the same or substantially the same as the length of the electrodes of tube **3900E**. Vertical strip **3952** includes two end portions **3952A** and **3952C** separated by a middle portion **3952B**. In one embodiment, the end portions **3952A** and **3952C** have a substantially equal length, which is about four times longer than the length of the middle portion **3952B**. Band **3950** extends from a bottom end of vertical strip end portion **3952A** to a top end of vertical strip middle portion **3952B**.

[0117] Horizontal strip **3954** intersects the vertical strip **3952** at the middle portion **3952B**, and extends in a lateral direction around at least a portion of the circumference of the tube **3900E**. In one embodiment, band **3950** is a solid color band (e.g., gray), and horizontal strip **3954** is a solid color strip (e.g., white). In one embodiment, vertical strip portions **3952A** and **3952C** are formed from the same solid color (e.g., blue), which is different than the solid color of vertical strip portion **3952B** (e.g., white). The colors are selected in one embodiment to differentiate the bands from blood and surrounding tissue.

[0118] One embodiment is directed to an apparatus for monitoring EMG signals of a patient's laryngeal muscles. The apparatus includes an endotracheal tube having an exterior surface and conductive ink electrodes formed on the exterior surface. The conductive ink electrodes are configured to receive the EMG signals from the laryngeal muscles when the endotracheal tube is placed in a trachea of the patient. At least one conductor is coupled to the conductive ink electrodes and is configured to carry the EMG signals received by the conductive ink electrodes to a processing apparatus.

[0119] The conductive ink electrodes according to one embodiment comprise a silver filled polymer conductive ink or a carbon conductive ink. In one embodiment, the conductive ink electrodes include at least six conductive ink electrodes that extend longitudinally along a length of the tube and that are spaced apart to surround a circumference of the endotracheal tube. The apparatus according to one embodiment includes an inflatable cuff connected to the endotracheal tube, and at least one conductive ink electrode formed on the inflatable cuff and configured to sense EMG signals from vocal folds of the patient. In one embodiment, at least one of a light source and a magnet is positioned on the endotracheal tube near the conductive ink electrodes.

[0120] One embodiment of the apparatus includes a coupling adapter configured to allow a proximal end of the endotracheal tube to rotate with respect to a distal end of the endotracheal tube. In one embodiment, the apparatus includes a first rib surrounding the endotracheal tube and positioned above the conductive ink electrodes on the endotracheal tube, and a second rib surround the endotracheal tube and positioned below the conductive ink electrodes on the endotracheal tube. At least one automatic periodic stimulation (APS) electrode is formed on the endotracheal tube in one embodiment, and the processing apparatus is configured to determine a position of the endotracheal tube based on signals generated by the at least one APS electrode. In one embodiment, at least one of a conducting hydro gel and an expandable, conductive foam is formed on the electrodes.

[0121] The endotracheal tube comprises a braided endotracheal tube in one embodiment. In one embodiment, the electrodes include four electrodes and the at least one conductor includes at least four pairs of conductors, and each pair of conductors is coupled to a different pair of the four electrodes to provide at least four channels of EMG signals from the four electrodes. In one form of this embodiment, the processing apparatus is configured to analyze the four channels of EMG signals and identify a subset of the four channels to display based on the analysis. At least one wireless sensor is provided on the endotracheal tube in one embodiment, with the at least one wireless sensor configured to wirelessly transmit information to the processing apparatus. In one embodiment, each of the electrodes is at least

about 1.9 inches in length. The electrodes form an electrode grid with at least two horizontal electrodes and at least two vertical electrodes. In one embodiment the apparatus includes at least one of a temperature sensing element, fiber optic element, and video element. In one embodiment, the apparatus includes at least one of a strain measurement element, an acceleration measurement element, and a piezo-electric element.

[0122] Another embodiment is directed to a method of monitoring EMG signals of a patient's laryngeal muscles. The method includes providing an endotracheal tube having an exterior surface and conductive ink electrodes formed on the exterior surface. The EMG signals from the laryngeal muscles are sensed with the conductive ink electrodes when the endotracheal tube is placed in a trachea of the patient. The EMG signals sensed by the conductive ink electrodes are output to a processing apparatus.

[0123] Another embodiment is directed to an apparatus for monitoring EMG signals of a patient's laryngeal muscles. The apparatus includes an endotracheal tube having an exterior surface. Four electrodes are formed on the exterior surface of the endotracheal tube. The four electrodes are configured to receive the EMG signals from the laryngeal muscles when the endotracheal tube is placed in a trachea of the patient. At least four pairs of conductors are coupled to the four electrodes and configured to carry the EMG signals received by the electrodes to a processing apparatus. Each pair of the conductors is coupled to a different pair of the four electrodes to provide at least four channels of EMG signals from the four electrodes.

[0124] Although embodiments set forth herein have been described in the context of an EMG endotracheal tube, it will be understood that the techniques are also applicable to other types of devices, such as a tube for monitoring a patient's anal sphincter or urethral sphincter.

[0125] Although the present disclosure has been described with reference to preferred embodiments, workers skilled in the art will recognize that changes can be made in form and detail without departing from the spirit and scope of the present disclosure.

What is claimed is:

1. A method, comprising:

providing an endotracheal tube having an exterior surface and at least eight electrodes on the exterior surface; and monitoring at least one nerve of a patient using the electrodes, wherein the monitoring includes sending, by the electrodes, at least four channels of monitoring signals to a multi-channel nerve integrity monitor device.

2. The method of claim 1, and further comprising:

sending, by the electrodes, at least six channels of monitoring signals to the multi-channel nerve integrity monitor device.

3. The method of claim 1, and further comprising:

carrying the monitoring signals from the electrodes to the multi-channel nerve integrity monitor device with a plurality of conductors.

4. The method of claim 1, and further comprising:

analyzing, with the multi-channel nerve integrity monitor device, the at least four channels of monitoring signals sent by the electrodes; and

identifying, with the multi-channel nerve integrity monitor device, a subset of the at least four channels to display based on the analysis.

5. The method of claim 4, wherein the identifying the subset of the at least four channels comprises identifying one of the channels having a best one of the monitoring signals.

6. The method of claim 4, wherein the identifying the subset of the at least four channels comprises identifying one of the channels having a largest one of the monitoring signals.

7. The method of claim 1, and further comprising:

positioning at least a portion of the endotracheal tube in a region of a trachea of the patient with at least some of the electrodes in contact with at least a portion of the trachea, wherein the at least four channels of monitoring signals include at least one channel of monitoring signals from the trachea.

8. A system, comprising:

an endotracheal tube having an exterior surface and at least eight electrodes on the exterior surface for monitoring at least one nerve of a patient; and

a multi-channel nerve integrity monitor device configured to receive at least four channels of monitoring signals from the electrodes.

9. The system of claim 8, wherein the at least eight electrodes are conductive ink electrodes that are printed directly on the exterior surface of the endotracheal tube.

10. The system of claim 8, wherein the endotracheal tube includes at least one tape that is stuck to the surface of the endotracheal tube and includes the at least eight electrodes.

11. The system of claim 8, wherein at least one of the electrodes has a sinusoidal shape.

12. The system of claim 8, wherein all of the electrodes have a sinusoidal shape.

13. The system of claim 8, wherein the multi-channel nerve integrity monitor device is configured to analyze the at least four channels of monitoring signals received from the electrodes, and identify a subset of the at least four channels to display based on the analysis.

14. The system of claim 8, wherein the multi-channel nerve integrity monitor device is configured to receive at least six channels of monitoring signals from the electrodes.

15. The system of claim 8, wherein the multi-channel nerve integrity monitor device includes a two-channel mode and a four-channel mode.

16. The system of claim 8, wherein the endotracheal tube includes a visual indicator for tracking and verifying location of the electrodes.

17. The system of claim 8, wherein the electrodes are laterally offset to surround a circumference of the endotracheal tube.

18. The system of claim 8, and further comprising a plurality of conductors to carry the monitoring signals from the electrodes to the multi-channel nerve integrity monitor device.

19. A multi-channel nerve integrity monitor device, comprising:

at least four channels configured to receive a plurality of monitoring signals from at least eight electrodes on an endotracheal tube; and

an analyzer configured to analyze the plurality of monitoring signals, and identify a subset of the plurality of monitoring signals to display based on the analysis.

20. The multi-channel nerve integrity monitor device of claim 19, wherein the analyzer is configured to identify a best one of the monitoring signals.

21. An apparatus, comprising:
an endotracheal tube having an exterior surface;
at least eight electrodes on the exterior surface, wherein
the electrodes have a sinusoidal shape and are configured to monitor at least one nerve of a patient, wherein the electrodes are laterally offset to surround a circumference of the endotracheal tube, and wherein the electrodes are configured to send at least four channels of monitoring signals to a multi-channel nerve integrity monitor device;
a plurality of conductors configured to carry the monitoring signals from the electrodes to the multi-channel nerve integrity monitor device; and
a visual indicator positioned on the endotracheal tube for tracking and verifying location of the electrodes.

* * * * *