



US 20190346707A1

(19) **United States**

(12) **Patent Application Publication** (10) **Pub. No.: US 2019/0346707 A1**

Scerbak et al.

(43) **Pub. Date: Nov. 14, 2019**

(54) **SINGLE AND MULTI-STAGE HIGH POWER OPTICAL ISOLATORS USING A SINGLE POLARIZING ELEMENT**

Publication Classification

(51) **Int. Cl.**
G02F 1/09 (2006.01)
(52) **U.S. Cl.**
CPC *G02F 1/093* (2013.01)

(71) Applicant: **Electro-Optics Technology, Inc.**,
Traverse City, MI (US)

(57) **ABSTRACT**

(72) Inventors: **David G. Scerbak**, Traverse City, MI (US); **Evan Rogers**, Traverse City, MI (US); **Amir Jalali Roudsar**, Traverse City, MI (US); **Joseph R. Mambourg**, Spring Lake, MI (US)

An optical isolator for generally collimated laser radiation includes a single polarizing element, at least one Faraday optical element, at least one reciprocal polarization altering optical element disposed at the single polarizing element, at least one reflective optical element for reflecting radiation to provide an even number of passes through the at least one Faraday optical element, and a magnetic structure. The magnetic structure is capable of generating a magnetic field within the at least one Faraday optical element that is generally aligned with the even number of passes along a beam propagation axis. The optical isolator is configured to receive generally collimated laser radiation, which passes through the single polarizing element and the at least one reciprocal polarization altering optical element and which makes at least two passes through the at least one Faraday optical element, whereby generally collimated laser radiation is output from the optical isolator.

(21) Appl. No.: **16/521,731**

(22) Filed: **Jul. 25, 2019**

Related U.S. Application Data

(63) Continuation of application No. 15/381,502, filed on Dec. 16, 2016.

(60) Provisional application No. 62/269,349, filed on Dec. 18, 2015.

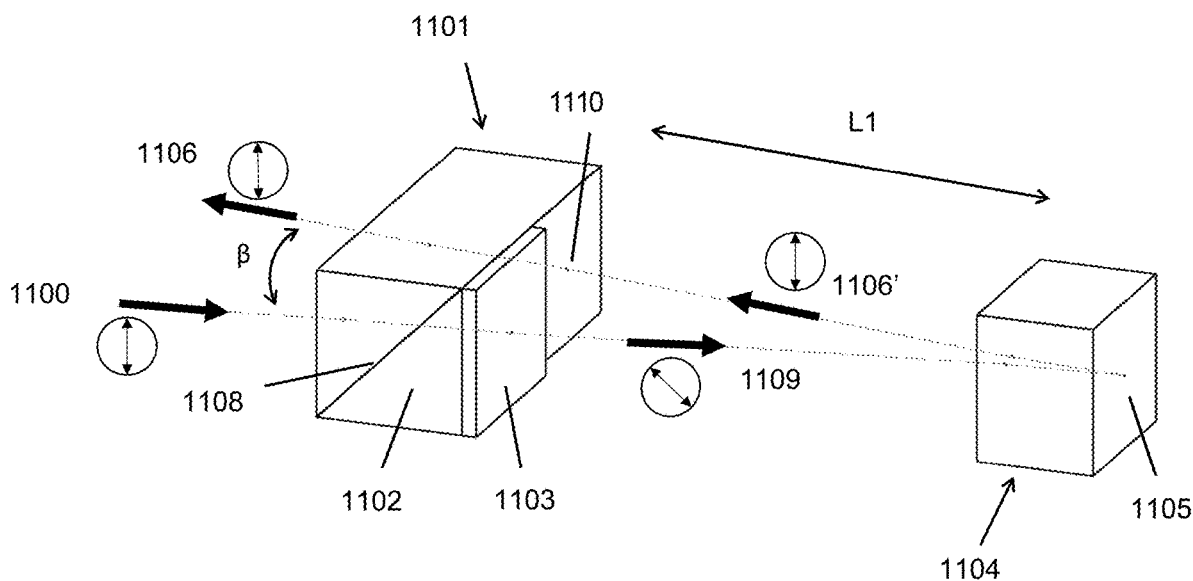

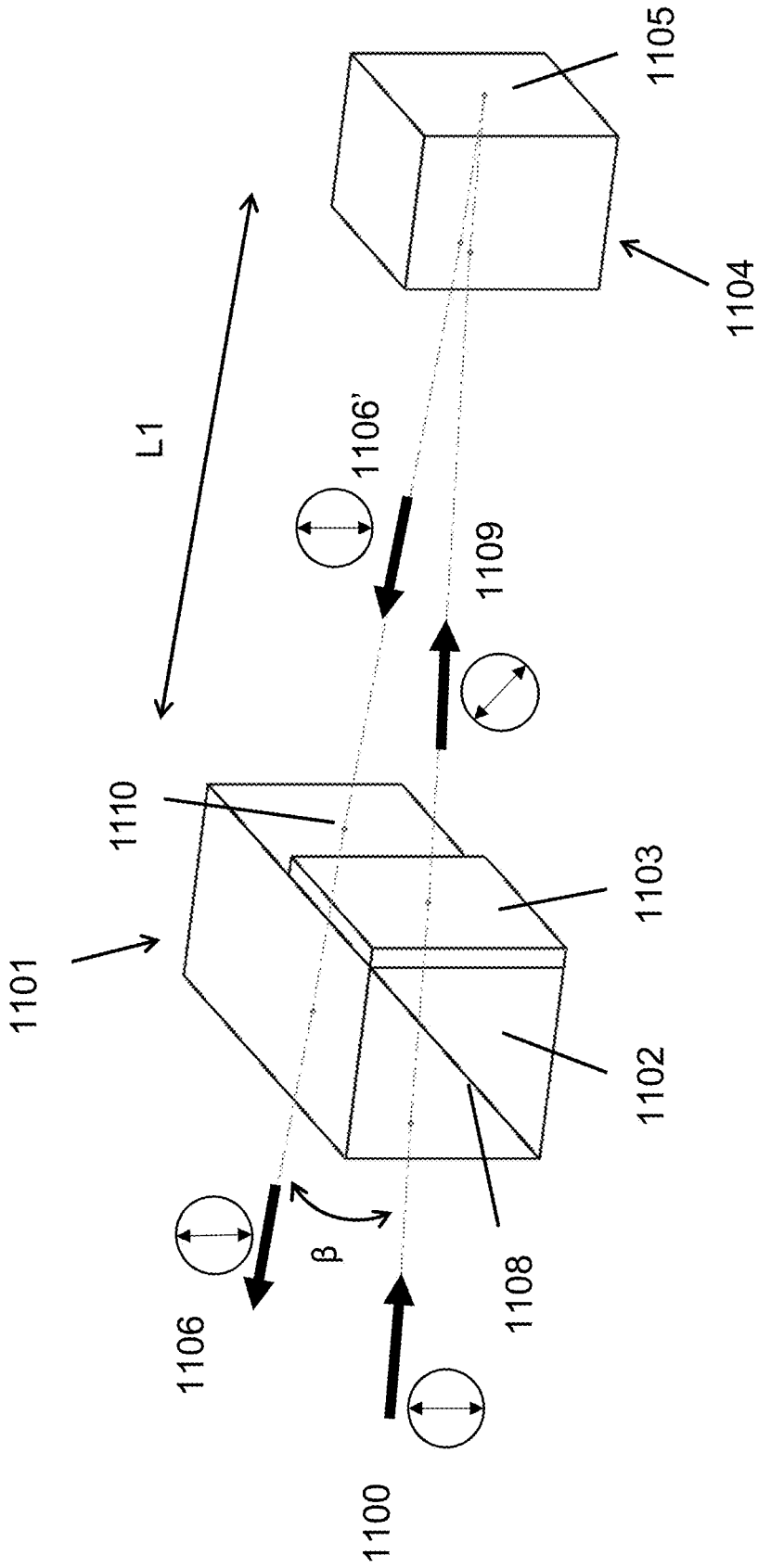

FIG. 1A

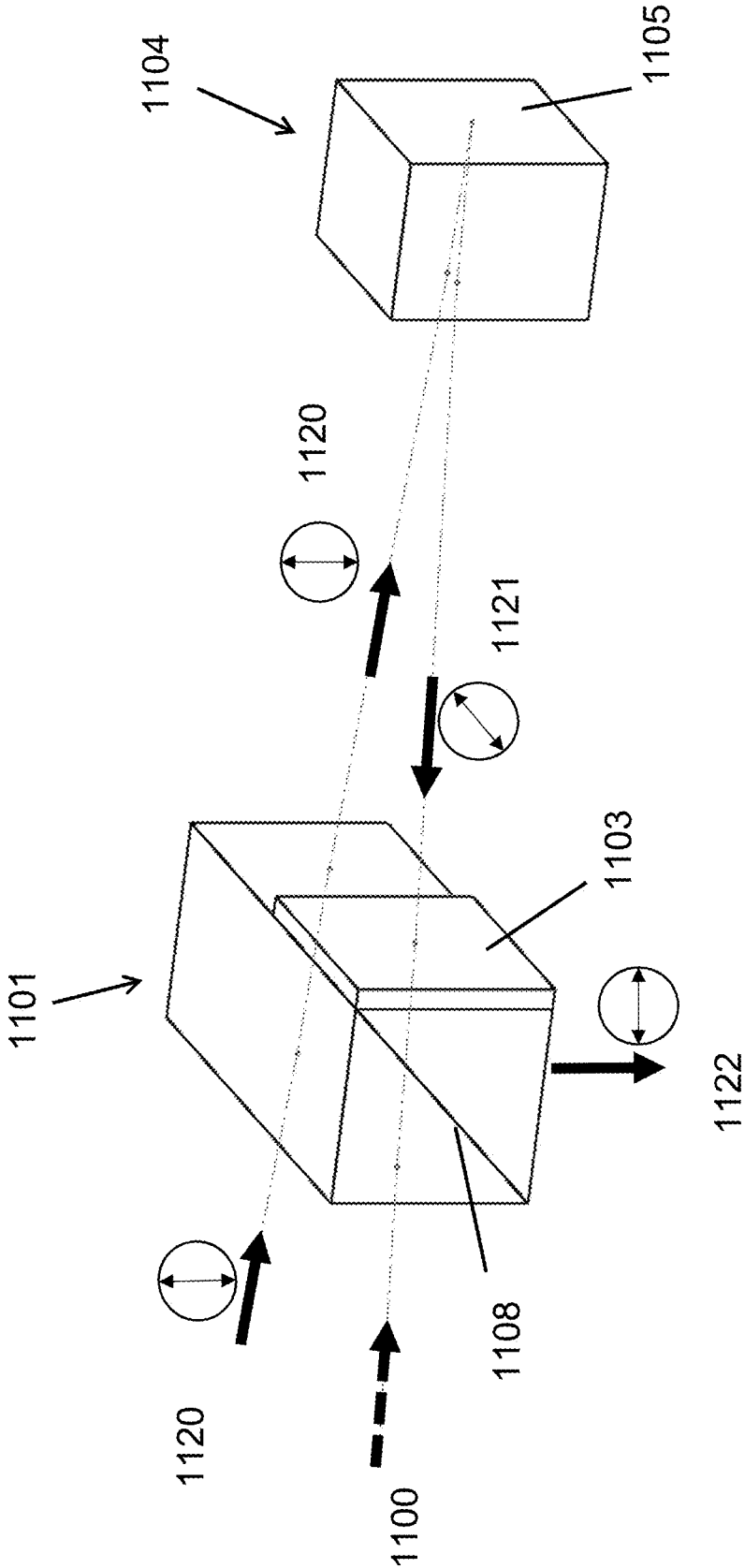

FIG. 1B

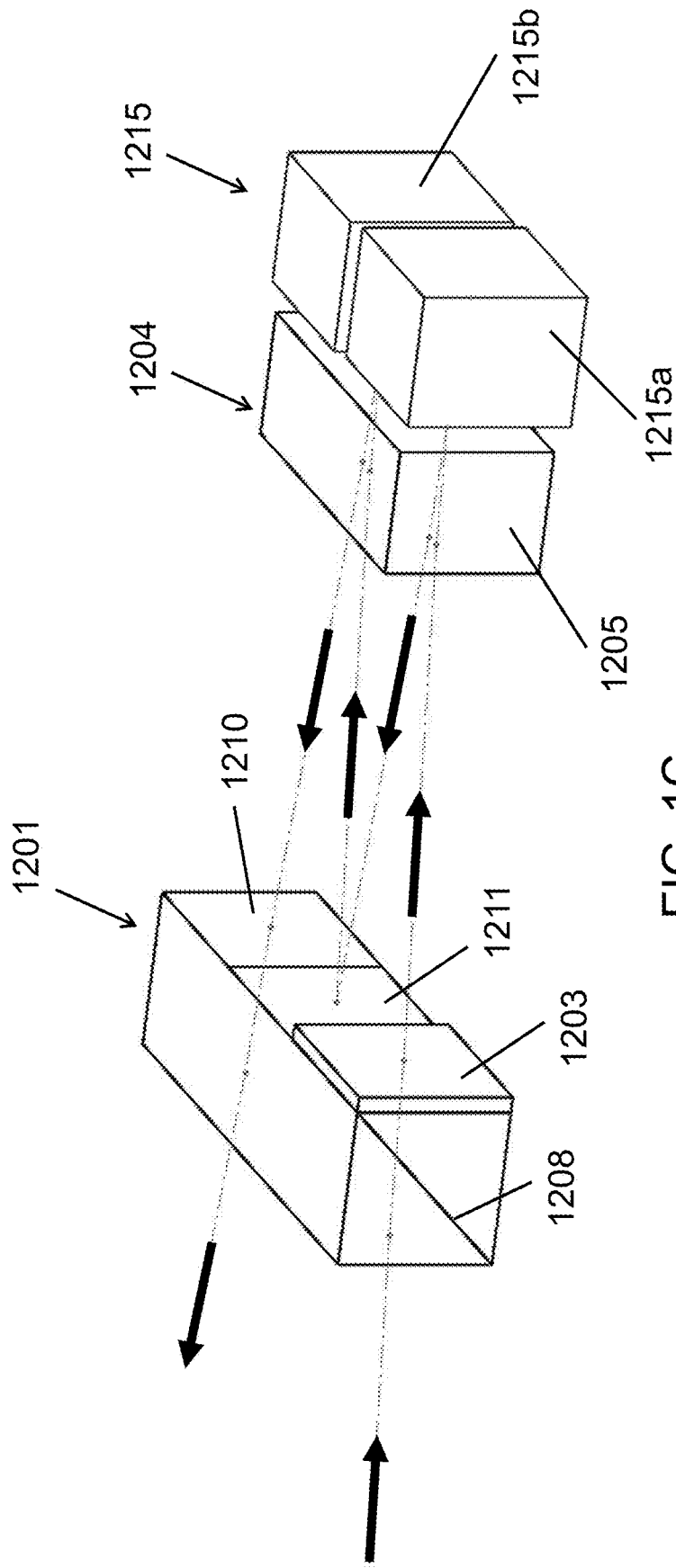

FIG. 1C

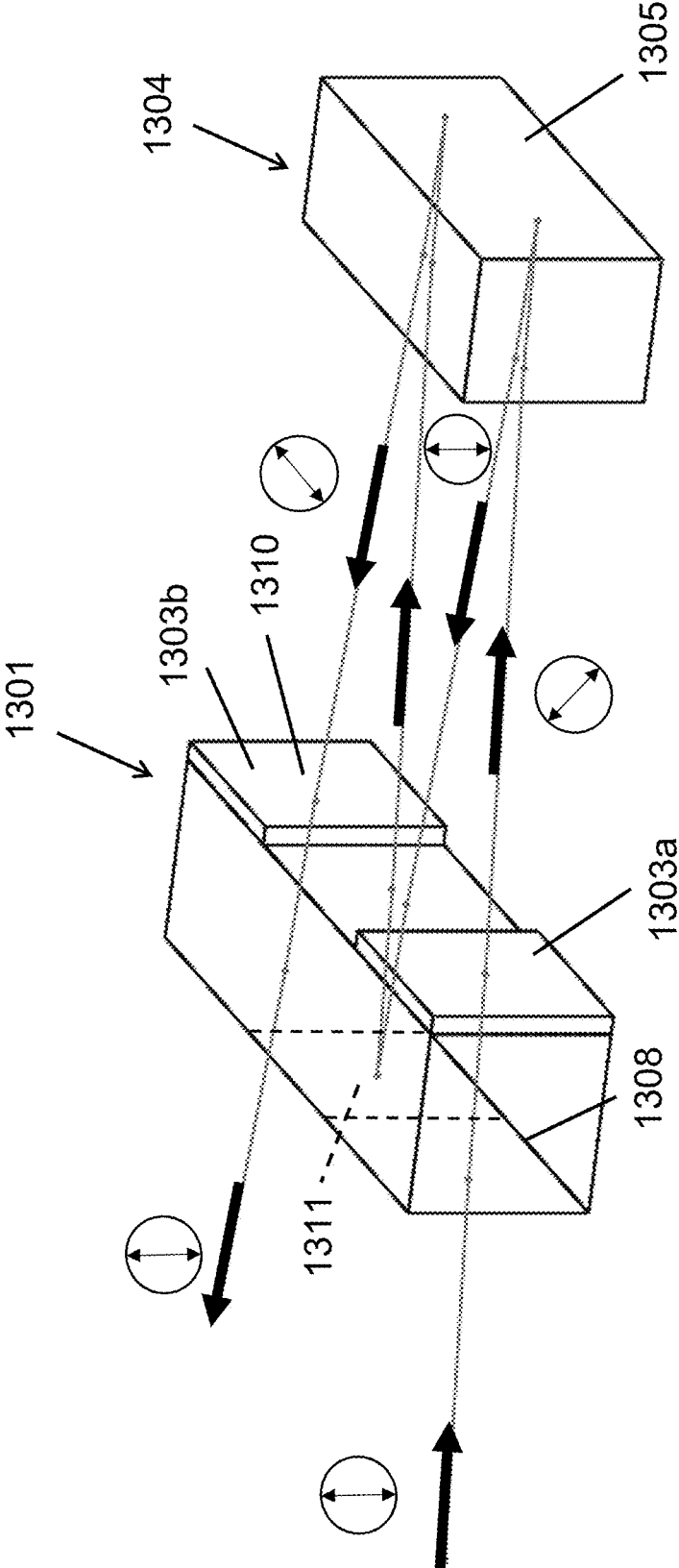

FIG. 1D

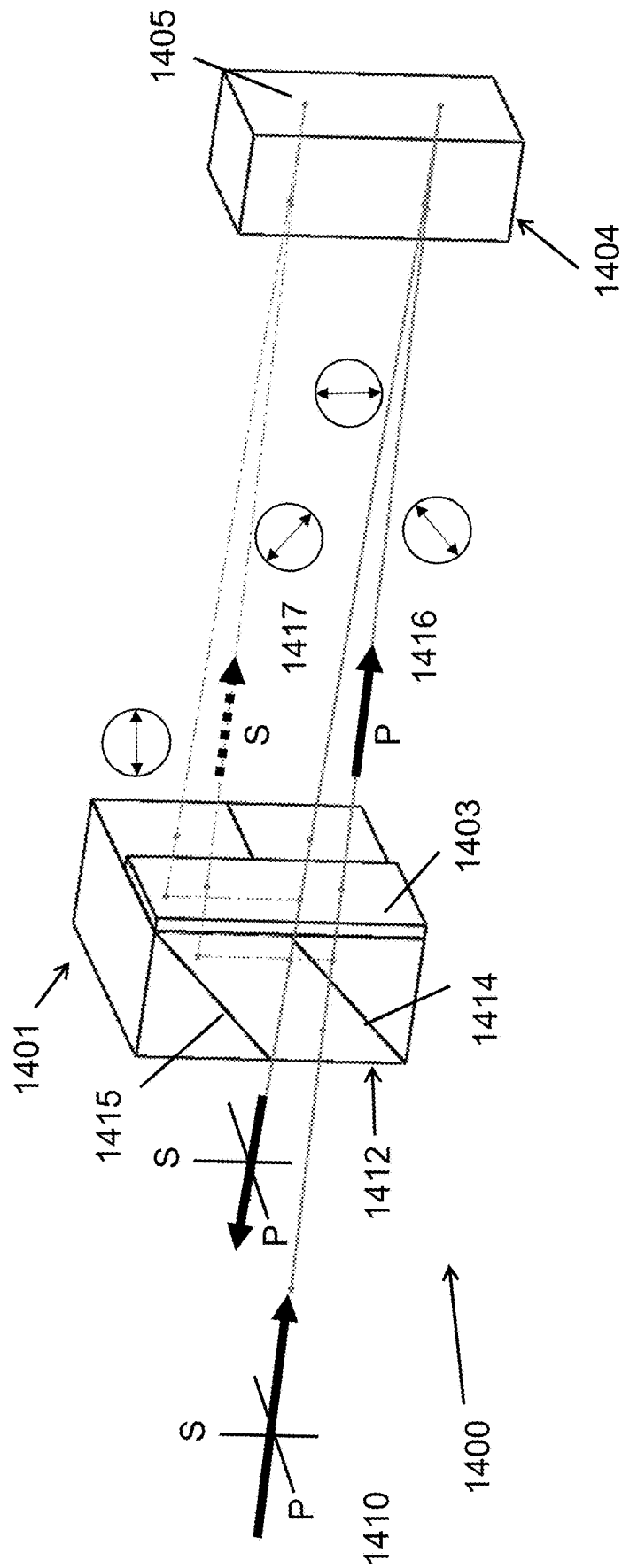
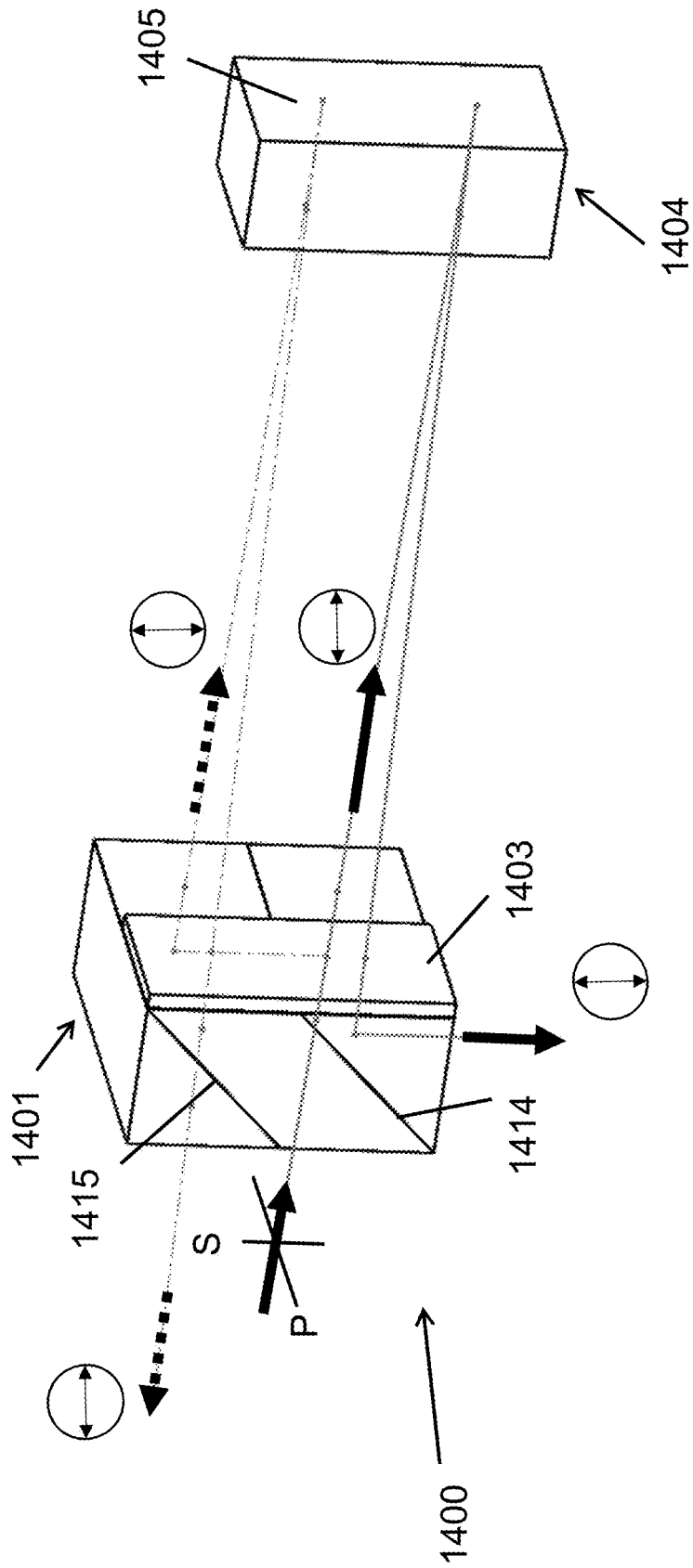

FIG. 2A



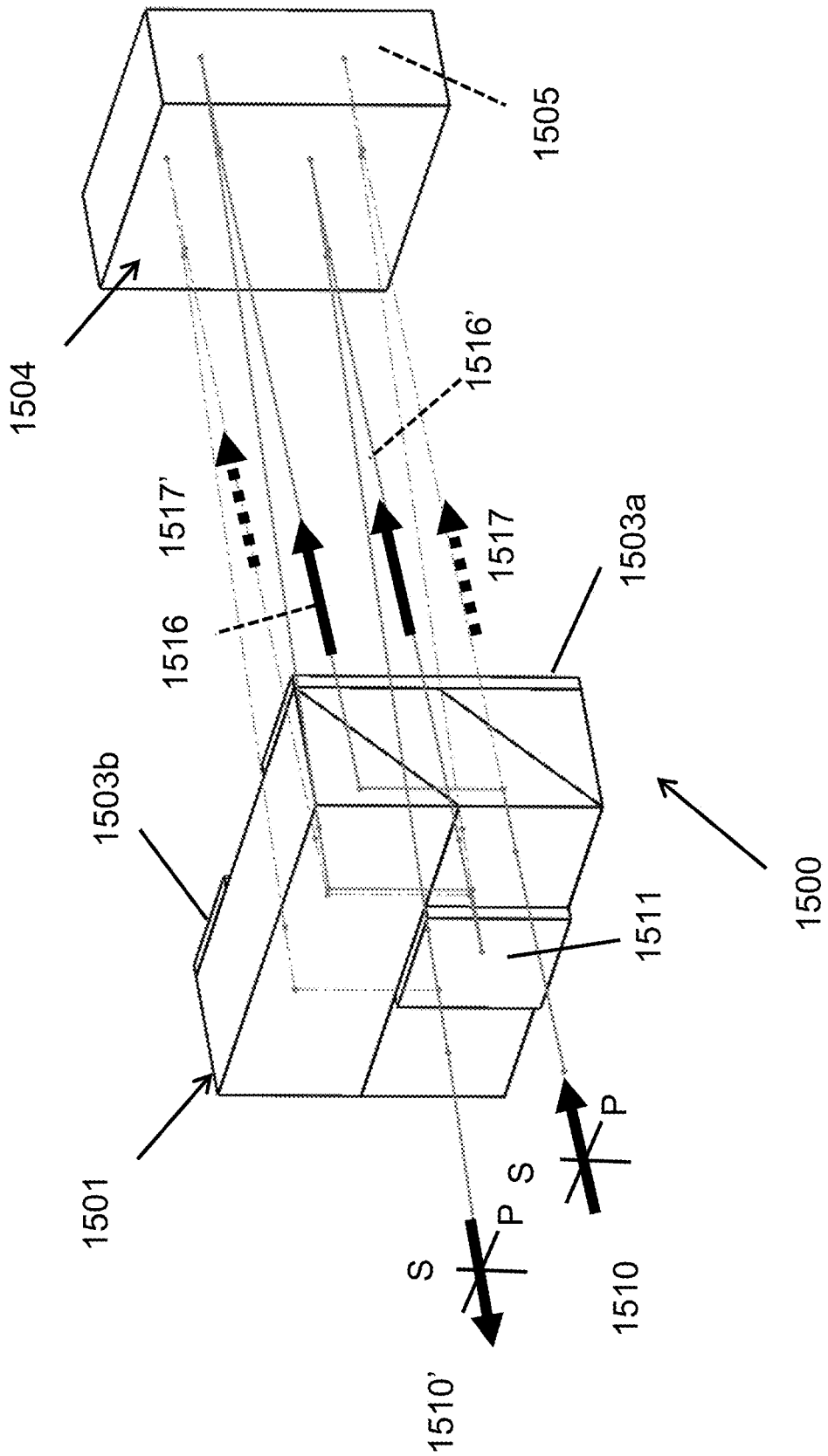

FIG. 3A

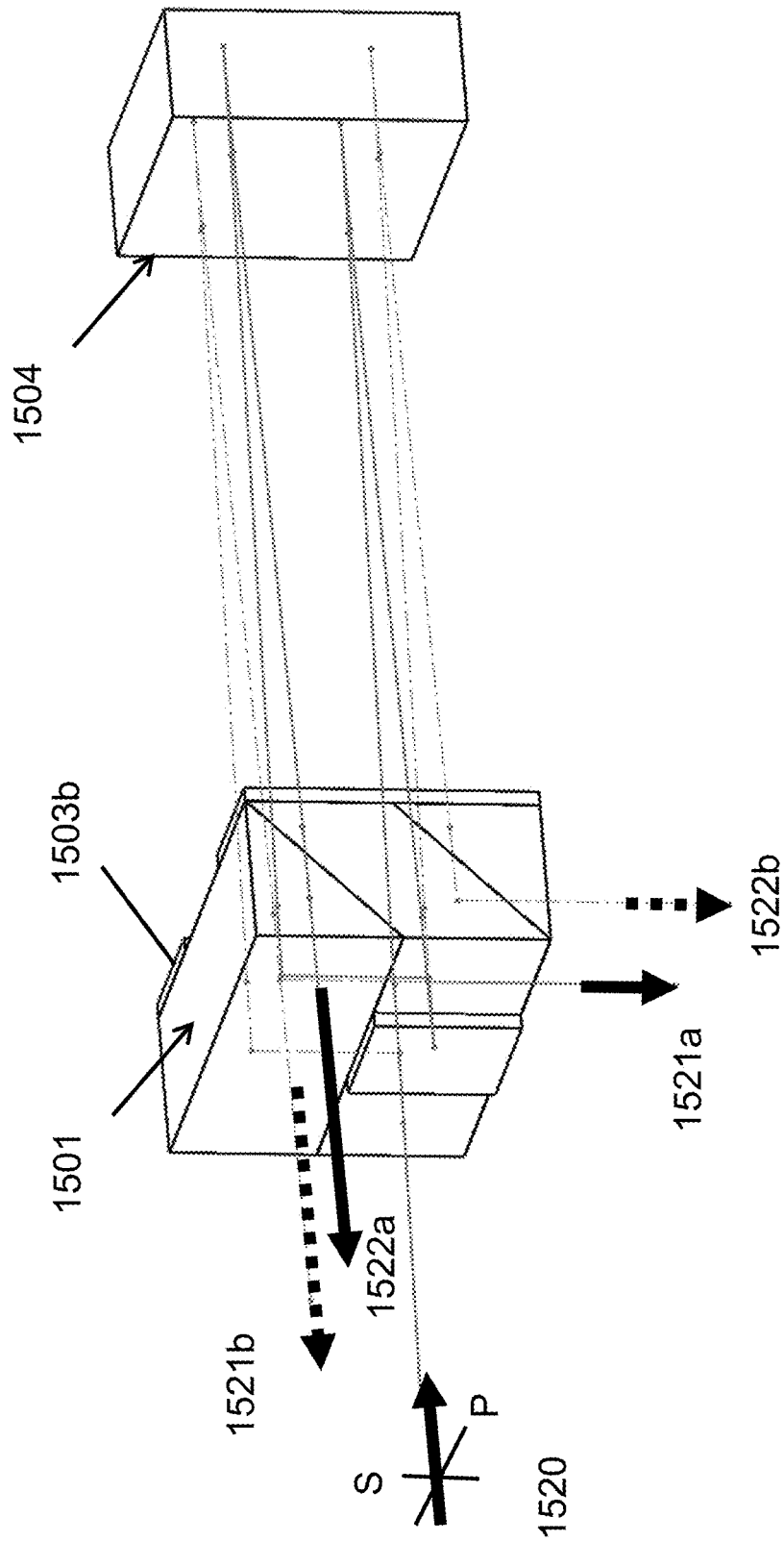
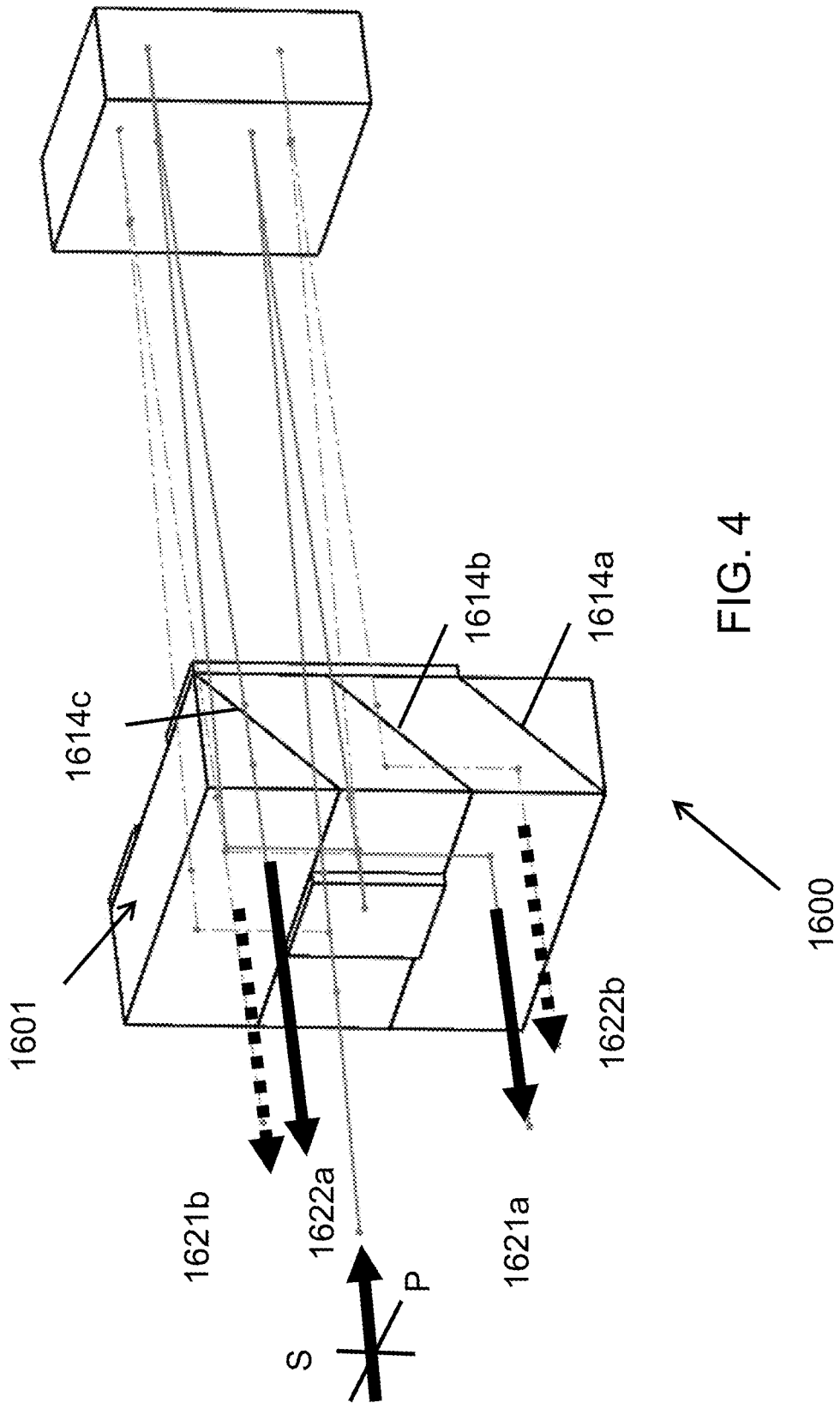

FIG. 3B



SINGLE AND MULTI-STAGE HIGH POWER OPTICAL ISOLATORS USING A SINGLE POLARIZING ELEMENT

CROSS REFERENCE TO RELATED APPLICATIONS

[0001] The present application is a continuation of U.S. patent application Ser. No. 15/381,502, filed Dec. 16, 2016, which claims the filing benefits of U.S. provisional application Ser. No. 62/269,349, filed Dec. 18, 2015, which are hereby incorporated herein by reference in their entireties.

FIELD OF THE INVENTION

[0002] The present invention relates to high power optical isolators and more particularly to high power single and multi-stage polarization maintaining ["PM"] and polarization insensitive ["PI"] optical isolators.

BACKGROUND OF THE INVENTION

[0003] Optical isolators are routinely used to decouple a laser oscillator from downstream laser amplifier noise radiation and/or target reflections. Optical isolators are typically comprised of a Faraday rotator surrounded by polarizers that are aligned with the input and output linear polarization states. A Faraday rotator is typically comprised of a non-reciprocal, optical element in a strong magnetic field that is co-axially aligned with the laser radiation so that the plane of polarization is rotated by 45 degrees. In an optical isolator, the non-reciprocal nature of the Faraday effect causes the plane of linear polarization in the backward propagating direction to be rotated an additional 45 degrees resulting in a polarization state which is 90 degrees to the transmission axis of the input polarizer. This results in reverse propagating radiation to experience high transmission losses while allowing forward propagating radiation to experience low transmission losses. Optical isolators suitable for randomly polarized light are also common and are termed polarization insensitive ["PI"] isolators such as disclosed in U.S. Pat. No. 4,178,073.

[0004] The sensitivity of distributed feedback diode lasers and other components in telecom systems to feedback from backward propagating radiation has prompted the development of multi-stage PI isolators to increase isolation to 60 dB. An example of such a multi-stage isolator is a two stage device disclosed in U.S. Pat. No. 5,237,445. To address the bulk and expense of high power Faraday rotators in the near infrared, the amount of Faraday rotation as given by the following equation has been examined:

$$\theta(\lambda, T) = V(\lambda, T) \times H(r, T) \times L_F \quad (1)$$

where:

[0005] $\theta(\lambda, T)$: The Faraday rotation angle (a function of wavelength, λ , and temperature, T);

[0006] $V(\lambda, T)$: A proportionality constant, termed the Verdet constant, of the Faraday

[0007] element (a function of wavelength, λ , and temperature, T);

[0008] $H(r, T)$: The strength of the magnetic field in the direction of light through the Faraday element (a function of radial position r across the beam and temperature, T); and

[0009] L_F : The optical path length within the Faraday element.

[0010] Equation 1 states that the Faraday rotation angle can be increased by either an increase in the Verdet constant $V(\lambda, T)$, the magnetic field strength $H(r, T)$, or the Faraday element length L_F . In order to make an optical isolator as small and inexpensive as possible, multi-pass Faraday rotators have been disclosed, such as in U.S. Pat. Nos. 4,909,612; 5,715,080 and 7,057,791, which are hereby incorporated by reference in their entireties. The reduced gap between the magnets significantly improves the magnetic efficiency and uniformity of the magnetic assembly. As disclosed in U.S. Publication No. 2015/0124318 (which is hereby incorporated herein by reference in its entirety), these improvements increase the effective magnetic field $H(r, T)$ and allow for reductions in the optical path length L_F , magnetic material volume, and Faraday optic volume. The reduction of the optical path length L_F is additionally advantageous in high power applications for reductions in beam degradation due to absorption.

[0011] A fiber to fiber optical isolator for low power laser radiation is disclosed in U.S. Pat. No. 5,499,132. This optical isolator is applicable to only fiber to fiber devices and requires an internal focusing lens for proper operation. In addition, optical damage due to high fluence levels of the small beam diameters at the fibers as well as in the birefringent crystal plate prevents scaling of this device to powers above 10 W.

SUMMARY OF THE INVENTION

[0012] The present invention provides PM and PI multi-pass isolator forms that are simple to align, have few optical parts to assemble and work well with scalable beam diameters large enough to prevent optical damage in the optical elements of the isolator when used with high peak and average power laser sources. The present invention relates to high peak and average power optical isolators and more particularly to high power single and multi-stage polarization maintaining ["PM"] and polarization insensitive ["PI"] optical isolators with improved size, improved alignment simplicity, reduced parts count, and reduced cost.

[0013] According to an aspect of the present invention, an optical isolator for generally collimated laser radiation is provisioned with one or more isolation stages using a single polarizing element, a multi-pass Faraday rotator through which light passes an even number of times and one 45 degree reciprocal polarization rotation element per isolation stage. The single polarizing element enables simple alignment and reduced parts count in an optical isolator that is scalable in beam diameter for high power operation.

[0014] In a preferred embodiment, the multi-pass Faraday rotator comprises a Faraday optic with a highly reflective coating on one optical face and an anti-reflective coating on the opposite optical face nearest to the single polarizing element. A magnetic field generally aligned to the beam path in the multi-pass Faraday rotator causes 45 degree non-reciprocal polarization rotation in the Faraday optic for each isolation stage.

[0015] The 45 degree reciprocal polarization rotation element may comprise a quartz wave plate and may be bonded, such as by adhesive free optical contact for high power applications, to the surface of the single polarizing element at only a portion of the single polarizing element such that the wave plate is located in only one pass of the beam path

and is aligned for the opposite sense rotation that is opposite to the Faraday non-reciprocal rotation in the transmission direction.

[0016] Optionally, a high reflection region may be coated onto the single polarizing element's optical face that is adjacent to the anti-reflection coated surface of the Faraday optic, whereby increased beam overlap and reduced overall size can be realized for an even number of passes greater than two. If the single polarizing element is a fused silica polarizing beam splitter, a polarization maintaining or PM isolator suitable for high power with only two separate optical components is realized. Similarly, if the single polarizer element is a fused silica polarization splitting beam displacer, a polarization insensitive or PI isolator with only two separate optical components is realized with no critical alignment required. Both forms of isolators have readily scalable beam diameters for high power operation. High power beam quality is limited only by the thermal optic properties of the Faraday rotation optical element.

[0017] The present invention thus is an improvement over the systems and devices described in U.S. Pat. Nos. 4,909,612; 5,715,080 and 7,057,791, where two or more polarizing elements are used and high reflection faces are placed upon opposing optical faces of multi-pass Faraday optics to promote more than two passes through the Faraday optic. In contrast to the systems disclosed in these patents, the system of the present invention uses a single polarizing element to simplify construction while also reducing size and cost. In the multi-stage isolator form, the system of the present invention can be constructed with only two optical components and has the further benefit that the isolator is self-aligning with respect to polarization throughout the multi-stage isolator. In addition, the use of high reflection coating region(s) on the optical face of the polarizing element closest to the Faraday optic improves the magnetic efficiency by increasing the number of beam passes through the Faraday optic while maintaining beams that are generally parallel to the magnetic field, thereby reducing the thickness of the Faraday optic and minimizing the required magnetic structure. These distinctions can all be made while increasing the beam size, as required, to prevent optical damage to optical elements within the isolator to scale the power as desired up to the limit imposed by the thermal optic properties of the Faraday optic material used.

[0018] In accordance with another aspect of the present invention, multi-stage isolators can be realized by adding a high reflection coating region on the single polarizing element's optical surface furthest from the Faraday optic between duplicate isolation stages such as described above for the preferred embodiment. In the case of a PI isolator, this high reflection coating is best applied to the non-bonded external surface of a quartz quarter-wave plate to flip polarizations between pairs of isolation stages to make path-lengths identical for both polarizations. The quarter wave-plate may be first bonded, such as by optical contact, with its optic axis aligned 45 degrees to each polarization axis of the fused silica polarization splitting beam displacer. Again, simple multiple stage isolators with only two separate optical components that are self-aligning with respect to polarization for easy assembly are possible.

[0019] These and other objects, advantages, purposes and features of the present invention will become apparent upon review of the following specification in conjunction with the drawings.

BRIEF DESCRIPTION OF THE DRAWINGS

[0020] FIG. 1A is a perspective view of a PM single stage, dual pass isolator (showing forward propagation of the beam) in accordance with the present invention;

[0021] FIG. 1B is another perspective view of the PM single stage, dual pass isolator of FIG. 1A, showing reverse propagation of the beam;

[0022] FIG. 1C is a perspective view of a PM single stage, quad pass isolator in accordance with the present invention;

[0023] FIG. 1D is a perspective view of a PM dual stage, dual pass isolator in accordance with the present invention;

[0024] FIG. 2A is a perspective view of a PI single stage, dual pass isolator (showing forward propagation of the beam) in accordance with the present invention;

[0025] FIG. 2B is another perspective view of the PI single stage, dual pass isolator of FIG. 2A, showing reverse propagation of the beam;

[0026] FIG. 3A is a perspective view of a PI dual stage, dual pass isolator (showing forward propagation of the beam) in accordance with the present invention;

[0027] FIG. 3B is another perspective view of the PI dual stage, dual pass isolator of FIG. 3A, showing reverse propagation of the beam; and

[0028] FIG. 4 is a perspective view of a PI dual stage, dual pass isolator (showing reverse propagation of the beam) with a triple layer displacer in accordance with the present invention.

DETAILED DESCRIPTION OF THE INVENTION

[0029] Referring now to the drawings and the illustrative embodiments depicted therein, FIG. 1A is a perspective view of a PM single stage, dual pass isolator for generally collimated laser radiation that is comprised of only two separate optical components in accordance with the invention. Collimated laser radiation source **1100** with substantially linear p polarization is incident upon single polarization element **1101** comprised of quartz half-waveplate **1103** bonded, such as by adhesive free optical contact, to fused silica PBS **1102**. The optic axis of half-waveplate **1103** is rotated by an angle of 22.5 degrees with respect to the original linear p polarization axis (shown as vertical in FIG. 1A), such that highly polarized p polarization transmitted through polarizing coating **1108** is rotated by +45 degrees of reciprocal rotation in half-waveplate **1103** as shown by the circled polarization state arrow **1109**.

[0030] Laser radiation at **1109** is then incident upon Faraday optic **1104** (such as a Terbium Gallium Garnet (TGG) or other suitable Faraday optic element) which is immersed in a magnetic field that is generally aligned to the beam path, where the beam receives -22.5 degrees of non-reciprocal Faraday polarization rotation for each pass of Faraday optic **1104**. Reflection coating **1105** on Faraday optic **1104** facilitates the dual pass beam path in Faraday optic **1104** for -45 degrees of total non-reciprocal polarization rotation which restores the original p polarization state in beam **1106'** which is then re-incident upon single polarization element **1101** at point **1110** (where the re-incident location is at a location that does not have the half wave plate **1103** at the polarization element). Radiation from point **1110** is highly p polarized output radiation **1106** upon final pass through the single polarization element **1101**. In view of the angle β between collimated input radiation **1100** and output radiation **1106** as

well as the separation L_1 between single polarization element **1101** and Faraday optic **1104**, half-waveplate **1103** is dimensioned and positioned to not clip input **1100** or output **1106** radiation.

[0031] The single stage, dual pass isolator of FIG. 1A also limits or precludes light traveling in the reverse direction from reaching the source of light beam **1100** in FIG. 1A. As shown in FIG. 1B, light **1120** received at single polarizing element **1101** at the side or region of the element that does not have the half wave plate **1103**, passes through the single polarizing element and through the Faraday optic **1104**, which, after it reflects off reflector **1105** so as to make a second pass through the optic **1104**, is rotated -45 degrees (beam **1121**), which then passes through the half wave plate **1103**, which rotates the beam -45 degrees, such that the beam **1122** is an s polarized beam **1122**. Such an s polarized beam is reflected by the polarizing coating **1108** away from the source of the light beam **1100**.

[0032] Optionally, if more than two passes are desired through the PM single stage isolator, a reflector may be added at the single polarizing element such that light (after two passes through the Faraday optic) reflects back toward the Faraday optic for a third and fourth pass (such a single stage, quad pass isolator may be suitable for small magnets or a low Verdet constant Faraday optic). Such a configuration is shown in FIG. 1C, where the single polarizing element **1201** has a half wave plate **1203** and a polarizing coating **1208** similar to single polarizing element **1101**, discussed above, and the isolator includes a Faraday optic **1204** and reflector **1205** similar to the optic **1104** and reflector **1105** discussed above. Single polarizing element **1201** includes a reflector **1211**, such as at a center region between the half wave plate **1203** and the point or region **1210** where the light beam passes back through the single polarizing element **1201**. In this configuration, the Faraday optic **1204** comprises a thinner optic or less powered magnetic field, such that each pass through the optic only rotates the polarized light 11.25 degrees (half the rotation achieved by Faraday optic **1104**, discussed above), whereby after four passes through the Faraday optic **1204**, the light is rotated $+45$ degrees to counter the -45 degrees rotation achieved by the half wave plate **1203**. Thus, the light output from the Faraday optic (after the fourth pass) is "p" polarized light. Optionally, single polarizing element **1201**, Faraday optic **1204**, and reflector **1211** could be increased in size to support additional passes of the Faraday optic **1204**; further reducing the thickness of the Faraday optic or size of the magnetic structure (such as the magnetic structure **1215** of FIG. 1C, which may have two separate magnetic elements **1215a**, **1215b**, and/or which may be adjustable, as discussed below).

[0033] Optionally, a dual stage, dual pass isolator may include two half wave plates, one for the light at an input region of the single isolator and another at an output region of the single isolator. For example, and such as shown in FIG. 1D, a single polarizing element **1301** has a half wave plate **1303a** and a polarizing coating **1308** similar to single polarizing element **1101**, discussed above, and the isolator includes a Faraday optic **1304** and reflector **1305** similar to the optic **1104** and reflector **1105** discussed above. Single polarizing element **1301** further includes a reflector **1311**, such as at a center region between the half wave plate **1303a** and the point or region **1310** where the light beam passes back through the single polarizing element **1301**. The single

polarizing element **1301** also includes a second half wave plate **1303b** at region **1310**, such that the light from the Faraday optic **1304** (after its fourth pass through the Faraday optic) is rotated as it passes through the second half wave plate **1303b** so that the exiting beam is a p polarized beam. This is because a p polarized input beam will rotate -45 degrees when passing through first half wave plate **1303a**, and then will rotate back $+45$ degrees when making two passes through the Faraday optic **1304**, and then will rotate an additional $+45$ degrees when making another two passes through the Faraday optic (after reflecting off of reflector **1311**). The beam then is rotated back -45 degrees by the second half wave plate **1303b** to be a p polarized beam as it exits the single polarizing element **1301**.

[0034] The isolator of the present invention thus provides multiple passes through a Faraday optic. If only two passes are made through the Faraday optic, then more magnetic power may be needed at the optic, which may result in a larger package. By providing for four or more (even number of) passes through the Faraday optic, a smaller magnet package may be used at the Faraday optic.

[0035] Referring to FIG. 2A, a perspective view of a single stage, dual pass PI isolator **1400** is shown in accordance with the present invention. The isolator includes a polarizing element **1401** and a Faraday optic **1404**, with a half wave plate **1403** disposed at part of the polarizing element and a reflector **1405** disposed at the Faraday optic **1404**. In the illustrated embodiment, the polarizing element **1401** has a first polarizing coating **1414** and a second polarizing coating **1415** at the diagonal surfaces of parallelepiped **1412** that are similarly bonded, such as through optical contact, to fused silica prisms **1413**. Randomly polarized radiation **1410** from a source in the forward direction is resolved into "p" and "s" polarized beams **1416** and **1417**, respectively, at the first polarizing coating **1414**, with the s polarized beam being reflected upward by polarizing coating **1414**. The "s" polarized beam **1417** is further reflected at the second polarizing coating **1415** and then transmitted out of the output AR coated surface of parallelepiped **1412** precisely parallel to and displaced from the "p" polarized beam **1416**. As shown in FIG. 2A, the beams pass through the wave plate **1403** where they are rotated -45 degrees, and then the rotated p and s beams pass through the Faraday optic **1404** and reflect off of the reflector **1405**, so as to make two passes through the optic **1404** (where they are rotated back $+45$ degrees) and return towards the polarizing element **1401**. The beams enter the polarizing element at a location devoid of the half wave plate **1403**, whereby the s beam is reflected downward by the polarizing coating **1415** and further reflected by the polarizing coating **1414** so as to exit the polarizing element **1401** with the p beam.

[0036] For light traveling in the reverse direction (FIG. 2B), the 90 degree rotation ($+45$ degrees by the Faraday $+45$ degrees by the wave plate) in the reverse direction causes the upper beam (the beam reflected by the polarizing coatings **1414**, **1415**) to pass through the upper diagonal (not reflected by the polarizing coating **1415**) and the lower beam to be reflected by the lower diagonal polarizing coating **1414**. Thus, reverse propagation of light is precluded from exiting the isolator in the direction of the source of light beam **1410** of FIG. 2A. Therefore, reverse propagating light is unable to couple back into the source.

[0037] A two stage PI isolator is increasingly desired to manage back reflections from PI laser systems generating

over 100 W of average power. Leakage from traditional single stage isolators can be sufficient to be amplified to levels which are harmful to internal laser components. Referring to FIG. 3A, a perspective view of a dual stage, dual pass PI isolator **1500** is shown in accordance with the present invention. The isolator includes a polarizing element **1501** with half wave plates **1503a** and **1503b** and quarter wave plate **1511** disposed at part of the polarizing element and a reflector **1505** disposed at the Faraday optic **1504**. Collimated laser radiation **1510** is incident upon a single fused silica polarizing beam displacer **1501** (PBD) where it is resolved into forward propagating “s” polarization beam **1516** (solid line) and “p” polarization beam **1517** (dashed line). Both “p” and “s” polarization beams are transmitted through first isolation stage quartz half waveplate **1503a** which may be bonded to beam displacer **1501** with optic axis +22.5 degrees such that the “p” and “s” polarized beams experience a +45 degree polarization rotation about the forward propagation axis to be +45 and +135 degree polarized beams, respectively.

[0038] The beams **1516**, **1517** then make two passes through the Faraday optic **1504** (via reflection off of reflector **1505**) and return to the PBD **1501**, where the p beam passes through the PBD and through a 1/4 wave plate **1511** and reflects off a reflector at the back side of the wave plate **1511** so as to again propagate through the PBD **1501**. The s beam also passes through the PBD and reflects off of the upper reflector coating and again off of the lower reflector coating so as to pass through the 1/4 wave plate **1511** and reflects off a reflector at the back side of the wave plate **1511** so as to again propagate through the PBD **1501**.

[0039] After the first pass of the 1/4 wave plate **1511**, the light is circularly polarized. The reflection off of the back-side of the 1/4 wave plate causes a 180 degree phase shift thereby reversing the circularity. The return pass through the 1/4 wave plate converts the light back to being planar polarized, but with the light then being rotated 90 degrees, such that the s beam becomes a p beam and the p beam becomes an s beam. This allows the two beams to flip planes and travel the same path length. In other words, the now s beam **1517'** (formerly the p beam) now reflects off of the coatings in the PBD, while the now p beam **1516'** (formerly the s beam) now passes directly through the PBD. Thus, by the time the two beams have again passed through the Faraday optic and again passed through the PBD so as to exit the PBD as beam **1510'**, the s beams and p beams have traveled the same path length. For collimated laser light, this is very important and allows very high beam quality to be maintained. If a particular application does not require high beam quality, 1/4 wave plate **1511** could be removed and replaced with a high reflection coated region.

[0040] Thus, and as shown in FIG. 3A, the two beams will be reflected between Faraday optic high reflector **1505** (at the rear or opposite end of the Faraday optic **1504**) and single fused silica PBD first stage high reflector **1511** N times such that 2 N passes are made through Faraday optic **1504** before the two beams are incident upon single fused silica AR coated region of the beam displacer **1501**.

[0041] Reverse propagating radiation **1520** (FIG. 3B), will follow the identical ray path and polarization states until after the rays have been transmitted through the second stage half-waveplate where the -45 degrees of second stage Faraday rotation is added to -45 degrees of reciprocal second stage half-waveplate rotation to rotate the polariza-

tions of both beams by -90 degrees such that they are rejected away from the forward beam propagation axis as shown by rejected ray lines in FIG. 3B. As shown in FIG. 3B, one beam of reverse propagating beam **1520** passes through the PBD **1501** and wave plate **1503b** and reflects back from the Faraday optic **1504**, whereby it is rotated such that it reflects downward at the lower reflector coating of the PBD **1501** and exits as a first stage rejected beam **1521a**. The other polarized beam of the initial reverse propagating beam **1520** reflects upward in the PBD **1501** and further reflects to the Faraday optic and back, where it is rotated such that it passes through the PBD **1501** and exits the PBD as first stage rejected beam **1521b**.

[0042] After the residual radiation is reduced in power by typically 30 dB relative to the original back-reflected power in the second stage isolator, the polarizations are again flipped by quarter waveplate before repeating the process in the first isolation stage, where again -45 degrees of first stage Faraday rotation is added to -45 degrees of reciprocal first stage half-waveplate rotation to again rotate the polarizations of both beams by -90 degrees such that they are once again rejected away from the original forward beam propagation axis as shown by the lines **1522a**, **1522b** in FIG. 3B. With the first stage 30 dB isolation similar to the second stage 30 dB isolation, the residual radiation from the original back-reflected power level is reduced by approximately 60 dB, thereby ensuring that none of this back-reflected light can damage or disrupt the laser system.

[0043] Referring now to FIG. 4, an isolator **1600** comprises a single polarized beam displacer **1601** having three reflective layers or coatings **1614a**, **1614b**, **1614c**. The isolator **1600** operates in a similar manner to isolator **1500**, discussed above, for forward propagating beams. However, by adding a third layer to the displacer, all four rejected beams **1621a**, **1621b**, **1622a**, **1622b** can be directed in the same direction as they exit the isolator. This simplifies the beam dump and thermal management of the high power reverse power.

[0044] The reciprocal polarization rotators need not be half-waveplates, they could also be (quartz) optical rotators, for example, or other suitable reciprocal polarization rotators. All of the above quartz waveplates need not be bonded to the single fused silica PBD, however aligning their optical axis and then bonding such waveplates to fused silica optical components such as polarizing beam-splitter cubes by optical contact is desired. Bonding these quartz waveplates directly to the single fused silica PBD to form a single optical part during final assembly has the advantage of greatly reducing the overall cost, parts count and assembly time for the optical isolator of this invention. Thus, the present invention provides a high performance PI isolator that is scalable in power with beam diameter that can be fabricated with only two separate optical components.

[0045] Although specifics above were given for a TGG Faraday optic, any Faraday optic material may be used in accordance with the present invention, such as, for example, ferromagnetic, paramagnetic, semiconductor and diamagnetic materials and/or the like. In particular, diamagnetic materials which typically have a very low Verdet constant but often have extremely low absorption can function well as temperature insensitive optical isolators in accordance with the invention because their Verdet constant is only very weakly related to temperature. The specific signs of reciprocal and non-reciprocal rotation need not be limited to

those described above—they can be mutually reversed by reversing the sign of the applied magnetic field to the Faraday optic and rotating the direction of the reciprocal polarization rotators accordingly.

[0046] High reflection coatings should impart a pure 180 degree phase shift upon reflection and need not be limited to thin films as they can also be made from metal coatings.

[0047] The Faraday optics high reflection coated surface may have a protective overlayer, such as SiO₂ or the like, and then a metallization layer, such as gold or the like, so that the Faraday optic may be soldered directly to a heat sinking housing with, for example, a gold-tin solder layer for enhanced conduction of heat out through the high reflection coated surface. Heat flow substantially parallel to the beam path minimizes any radial heat flow across the beam cross section that can result in thermal lens focal shifts and thermal birefringence.

[0048] Optionally, it is another aspect of the present invention that the Faraday optic may comprise a layered structure with a transparent heat conductive layer bonded to one or both optical faces of a diamagnetic, paramagnetic or ferromagnetic Faraday rotating material. Such transparent heat conductive layers, in conjunction with sufficient multi-passes to ensure that the Faraday optic is thin relative to the beam diameter, ensures that heat flow is substantially parallel to the beam path within the Faraday optic. The function of the transparent heat conductive layer is described in detail in U.S. Publication No. 2014/0218795, which is hereby incorporated herein by reference in its entirety. Heat flow parallel to the beam path eliminates radial temperature gradients responsible for thermal lens focal shift and thermal birefringence.

[0049] Another aspect of the present invention is that the multi-pass Faraday rotator may use an adjustable magnetic structure that is capable of modifying the magnetic field strength generally aligned to the beam path with the Faraday optical element(s) used in the multi-pass Faraday rotator. In the case of multi-stage optical isolators, such magnetic field adjustability can be independent or different for each stage for improving the temperature and/or wavelength bandwidth performance of the optical isolator. The adjustable magnetic structure is adjustable relative to the optical elements via any suitable electrical or mechanical or electromechanical means that may adjust the space or gap between the magnetic structure and the optical element to provide the desired performance of the optical isolator. For example, and such as shown in FIG. 1C, an adjustable magnetic structure **1215** may include two magnetic structures **1215a** and **1215b**, which can be moved independently or in tandem (relative to the Faraday optic **1204**) to achieve different faraday rotations per stage.

[0050] Therefore, the present invention provides an optical isolator having one or more isolation stages using a single polarizing element in conjunction with a multi-pass Faraday rotator and one 45 degree reciprocal polarization rotation element per isolation stage for improved alignment simplicity, reduced parts count and lower cost. The multi-pass Faraday rotator optionally and desirably has an even number of multi-passes and may comprise a Faraday optic with a highly reflective coating on one optical face and an anti-reflective coating on the opposite optical face nearest to the single polarizing element. A magnetic field generally aligned to the beam path in the multi-pass Faraday rotator causes 45 degree non-reciprocal polarization rotation in the

Faraday optic for each isolation stage. The 45 degree reciprocal polarization rotation element may comprise a quartz waveplate that is bonded, such as by adhesive free optical contact for high power applications, to a surface of the single polarizing element in the optical path of only one pass of the beam and aligned for the opposite sense rotation to the Faraday non-reciprocal rotation.

[0051] Changes and modifications in the specifically described embodiments can be carried out without departing from the principles of the invention, which is intended to be limited only by the scope of the appended claims, as interpreted according to the principles of patent law including the doctrine of equivalents.

1. An optical isolator for collimated laser radiation, the optical isolator comprising:

a single polarizing element;

at least one Faraday optical element comprising opposing optical faces through which there is a beam propagation axis;

a first half-wave plate and a second half-wave plate disposed at the single polarizing element;

a single quarter-wave plate disposed at the single polarizing element;

at least one reflective optical element for reflecting radiation to provide an even number of passes through the at least one Faraday optical element;

a magnetic structure capable of generating a magnetic field within the at least one Faraday optical element, wherein the magnetic field is aligned with the even number of passes along the beam propagation axis;

wherein the optical isolator is configured to receive collimated laser radiation, which passes through the single polarizing element and splits into a first polarization beam and a second polarization beam, and wherein the first polarization beam has a different polarization than the second polarization beam;

wherein the first polarization beam and the second polarization beam each pass through the first half-wave plate, the single quarter-wave plate, and the second half-wave plate;

wherein the first polarization beam and the second polarization beam each make at least four passes through the at least one Faraday optical element;

wherein the first polarization beam and the second polarization beam pass through the single polarizing element and combine into collimated laser radiation; and

wherein collimated laser radiation is maintained throughout the optical isolator, and wherein the first polarization beam and the second polarization beam travel the same distance through the optical isolator.

2. The optical isolator of claim 1, wherein the single quarter-wave plate comprises a reflective surface, and wherein the first polarization beam and the second polarization beam pass through the single quarter-wave plate and become circularly polarized, and wherein the first polarization beam and the second polarization beam reflect off the reflective surface of the single quarter-wave plate and pass through the single quarter-wave plate a second time and become linearly polarized.

3. The optical isolator of claim 1, wherein the single polarizing element comprises a single fused silica polarizing beam displacer.

4. The optical isolator of claim 1, wherein the first half-wave plate comprises a first isolation stage quartz half-wave plate.

5. The optical isolator of claim 1, wherein the first half-wave plate and the second half-wave plate are bonded to the single polarizing element.

6. The optical isolator of claim 1, wherein the single quarter-wave plate is bonded to the single polarizing element.

7. The optical isolator of claim 1, wherein, after the first polarization beam and the second polarization beam pass through the single polarizing element, the first polarization beam and the second polarization beam pass through the first half-wave plate and then pass twice through the Faraday optical element.

8. The optical isolator of claim 7, wherein, after the first polarization beam and the second polarization beam pass twice through the Faraday optical element, the first polarization beam and the second polarization beam pass through the single quarter-wave plate and the single polarizing element twice.

9. The optical isolator of claim 1, wherein a first beam of reverse propagating radiation and a second beam of reverse propagating radiation pass through a second stage isolator, and wherein the second stage isolator comprises the single polarizing element, the second half-wave plate, and the Faraday optical element, and wherein, after passing through the second stage isolator, a first portion of the first beam of reverse propagating radiation and the second beam of reverse propagating radiation are rejected from the optical isolator.

10. The optical isolator of claim 9, wherein the first beam of reverse propagating radiation and the second beam of reverse propagating radiation pass through a first stage isolator, and wherein the first stage isolator comprises the single quarter-wave plate, the first half-wave plate, and the Faraday optical element, and wherein, after passing through the first stage isolator, a second portion of the first beam of reverse propagating radiation and the second beam of reverse propagating radiation are rejected from the optical isolator.

11. The optical isolator of claim 10, wherein the single polarizing element comprises two reflective layers.

12. The optical isolator of claim 10, wherein the single polarizing element comprises three reflective layers.

13. The optical isolator of claim 12, wherein the first portion of the first beam of reverse propagating radiation and the second beam of reverse propagating radiation and the second portion of the first beam of reverse propagating radiation and the second beam of reverse propagating radiation are all rejected in the same direction as they exit the optical isolator.

14. The optical isolator of claim 10, wherein, after passing through the second stage isolator and the first stage isolator, the first beam of reverse propagating radiation and the second beam of reverse propagating radiation are reduced by

60 dB relative to the original first beam of reverse propagating radiation and the original second beam of reverse propagating radiation, respectively.

15. The optical isolator of claim 1, wherein the first half-wave plate and the second half-wave plate comprise quartz optical rotators.

16. An optical isolator for collimated laser radiation, the optical isolator comprising:

a single polarizing element;

at least one Faraday optical element comprising opposing optical faces through which there is a beam propagation axis and a high reflection coated region;

a first half-wave plate and a second half-wave plate disposed at the single polarizing element;

at least one reflective optical element for reflecting radiation to provide an even number of passes through the at least one Faraday optical element;

a magnetic structure capable of generating a magnetic field within the at least one Faraday optical element, wherein the magnetic field is aligned with the even number of passes along the beam propagation axis;

wherein the optical isolator is configured to receive collimated laser radiation, which passes through the single polarizing element and splits into a first polarization beam and a second polarization beam, and wherein the first polarization beam has a different polarization than the second polarization beam;

wherein the first polarization beam and the second polarization beam each pass through the first half-wave plate and the second half-wave plate;

wherein the first polarization beam and second polarization beam reflect off of the high reflection coated region of the at least one Faraday optical element;

wherein the first polarization beam and the second polarization beam each make at least four passes through the at least one Faraday optical element;

wherein the first polarization beam and the second polarization beam pass through the single polarizing element and combine into collimated laser radiation; and

wherein collimated laser radiation is maintained throughout the optical isolator.

17. The optical isolator of claim 16, wherein, after the first polarization beam and the second polarization beam pass through the single polarizing element, the first polarization beam and the second polarization beam pass through the first half-wave plate and then pass twice through the Faraday optical element.

18. The optical isolator of claim 16, wherein the single polarizing element comprises two reflective layers.

19. The optical isolator of claim 16, wherein the single polarizing element comprises three reflective layers.

20. The optical isolator of claim 16, wherein the single polarizing element comprises a single fused silica polarizing beam displacer.

* * * * *