



(12) **United States Patent**
Antonelli

(10) **Patent No.:** **US 10,190,805 B2**
(45) **Date of Patent:** ***Jan. 29, 2019**

(54) **EASY-OPENING SOLAR COLLECTOR HAVING TEMPERATURE-RESPONSIVE MOUNT FOR POLYMER ABSORBER**

(2018.05); *F24S 2025/6003* (2018.05); *Y02B 10/20* (2013.01); *Y02E 10/40* (2013.01); *Y02E 10/44* (2013.01)

(71) Applicant: **UMA Distributors, LLC**, Altamonte Springs, FL (US)

(58) **Field of Classification Search**
CPC *Y02B 10/20*; *Y02B 10/22*; *Y02B 10/24*
See application file for complete search history.

(72) Inventor: **John L. Antonelli**, Clermont, FL (US)

(73) Assignee: **UMA Distributors, LLC**, Altamonte Springs, FL (US)

(56) **References Cited**

U.S. PATENT DOCUMENTS

(*) Notice: Subject to any disclaimer, the term of this patent is extended or adjusted under 35 U.S.C. 154(b) by 0 days.

This patent is subject to a terminal disclaimer.

3,987,783 A * 10/1976 Powell *F24S 10/75*
126/661
4,120,285 A * 10/1978 Nugent *F24S 23/77*
126/653

(Continued)

(21) Appl. No.: **15/675,051**

Primary Examiner — David J Laux

(22) Filed: **Aug. 11, 2017**

(74) *Attorney, Agent, or Firm* — Nicholas Pfeifer; Smith & Hopfen, P.A.

(65) **Prior Publication Data**

US 2017/0336103 A1 Nov. 23, 2017

Related U.S. Application Data

(63) Continuation of application No. 14/617,166, filed on Feb. 9, 2015, now Pat. No. 9,803,892.

(57) **ABSTRACT**

A solar collector housing that is opened and closed without tools includes structure for accommodating temperature-related expansion and contraction of a polymer absorber housed within the collector. The housing includes a transparent cover, a frame for holding the transparent cover, and a base. The cover, frame and base collectively define a hollow interior within which the polymer absorber is positioned. A plurality of latches is secured to an exterior of the frame. The frame and base are pivotally connected to one another when the latches are open so that the collector housing can be opened. The housing cannot be opened when the latches are closed. A pair of variable gate closure components are positioned in slots formed in a second end of the collector and enable the polymer absorber to expand and contract without placing stress on the absorber tubes.

(51) **Int. Cl.**

F24S 80/50 (2018.01)
F24S 40/80 (2018.01)
F24S 80/58 (2018.01)
F24S 80/40 (2018.01)
F24S 80/30 (2018.01)
F24S 40/10 (2018.01)

(Continued)

(52) **U.S. Cl.**

CPC *F24S 80/50* (2018.05); *F24S 10/73* (2018.05); *F24S 40/10* (2018.05); *F24S 40/80* (2018.05); *F24S 80/30* (2018.05); *F24S 80/40* (2018.05); *F24S 80/58* (2018.05); *F24S 70/14*

16 Claims, 10 Drawing Sheets

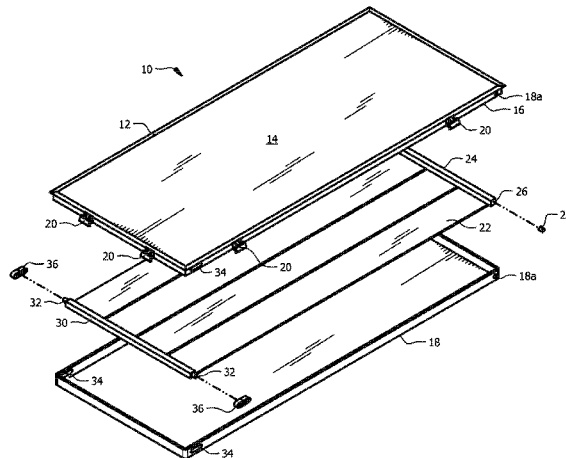

- (51) **Int. Cl.**
F24S 10/70 (2018.01)
F24S 25/60 (2018.01)
F24S 70/14 (2018.01)

(56) **References Cited**

U.S. PATENT DOCUMENTS

4,202,320 A *	5/1980	Bowen	F24S 10/504 126/660
4,471,764 A *	9/1984	Calvert	F24S 80/45 126/704
4,535,756 A *	8/1985	Rinehart	F24S 80/70 126/710
8,247,685 B2 *	8/2012	Hunter	F24S 30/425 136/259
2007/0199561 A1 *	8/2007	Soucy	F24S 80/40 126/623
2011/0226233 A1 *	9/2011	Schwarz	F24S 10/90 126/635

* cited by examiner

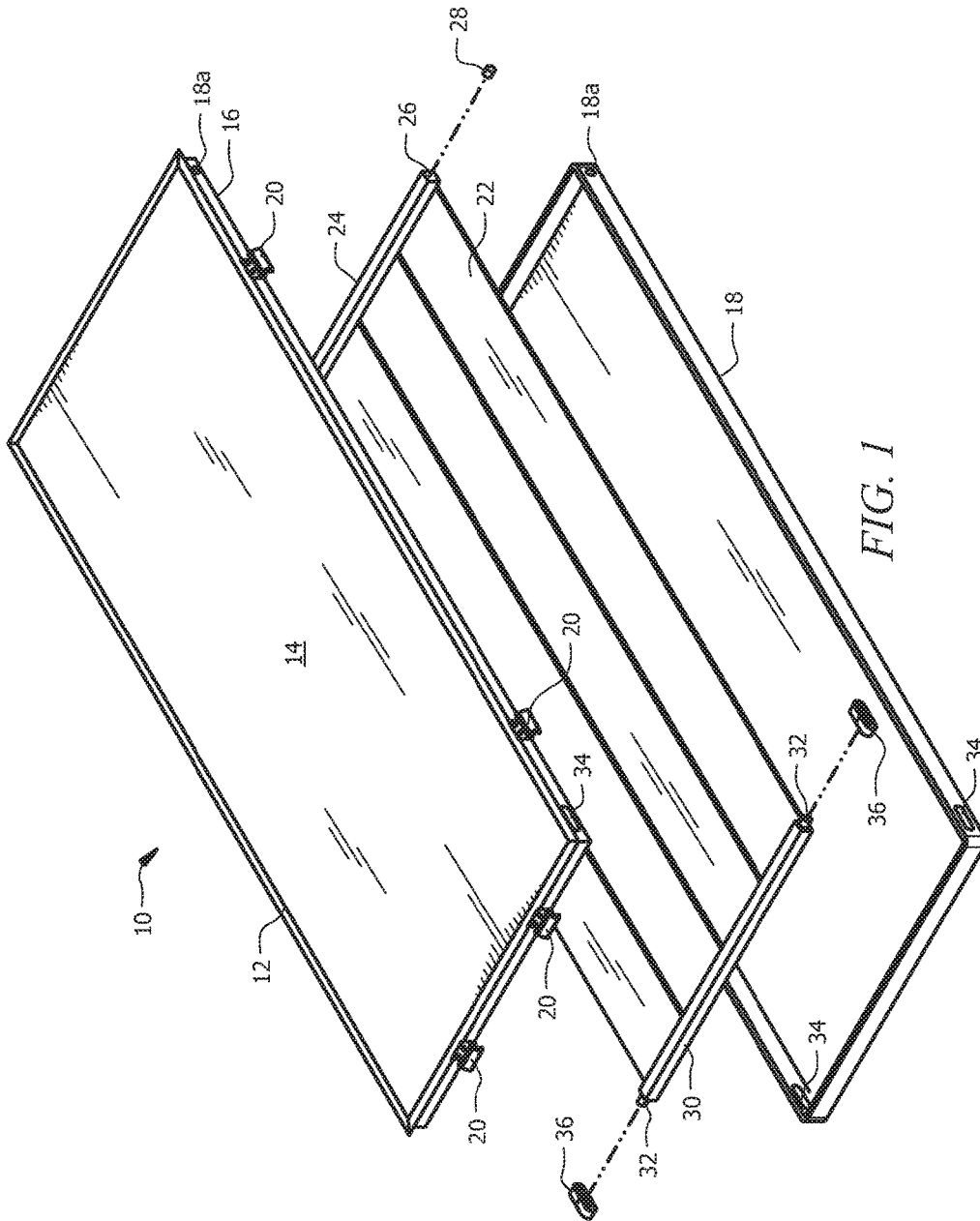

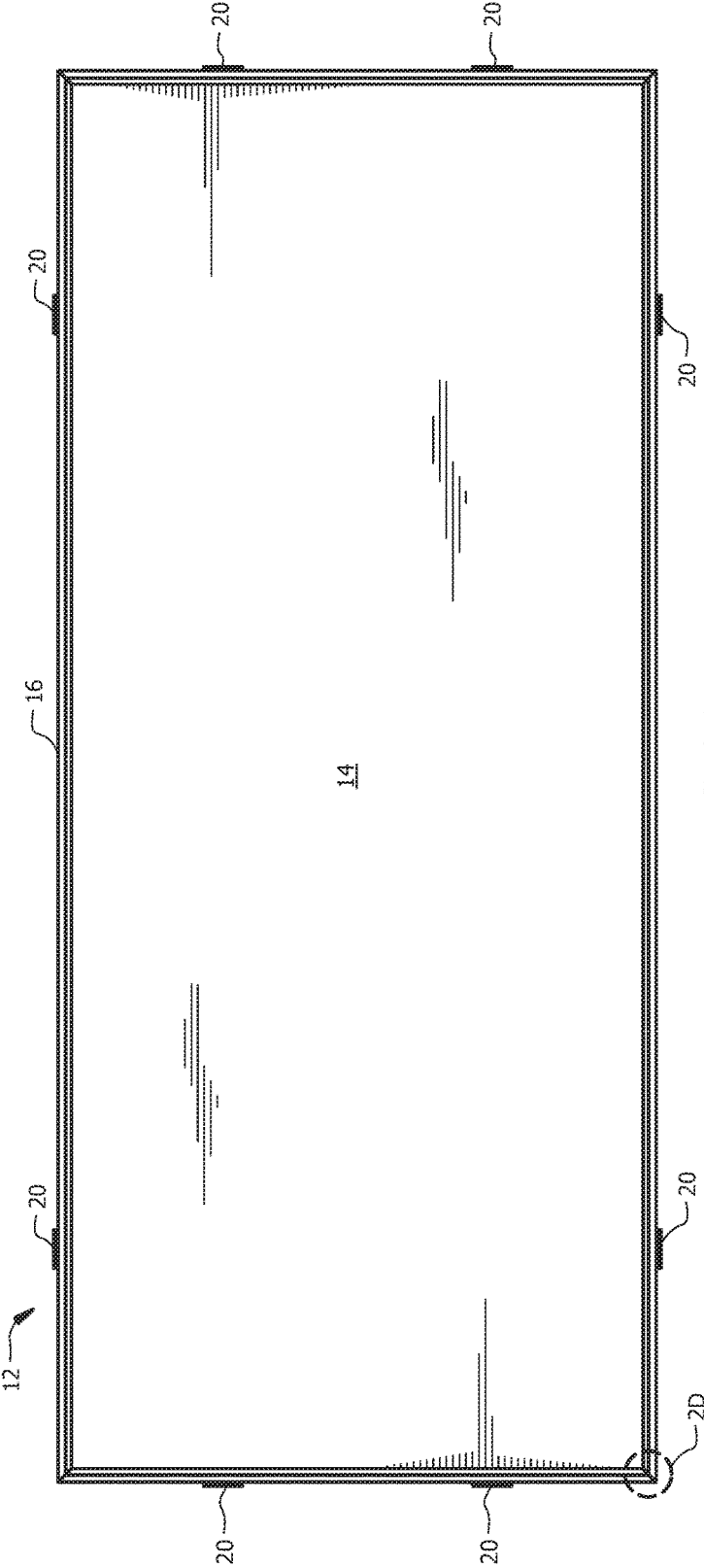

FIG. 2A

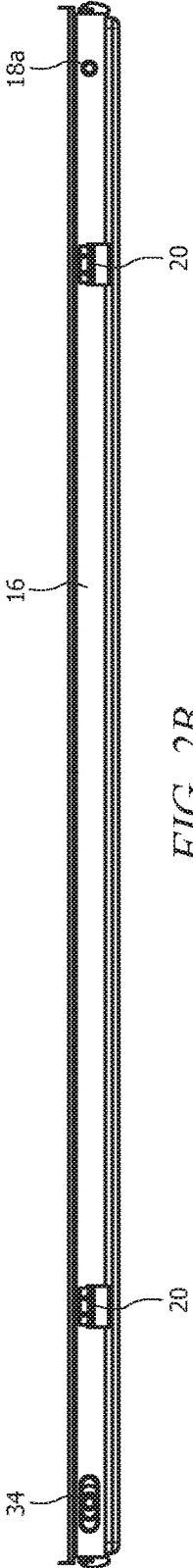

FIG. 2B

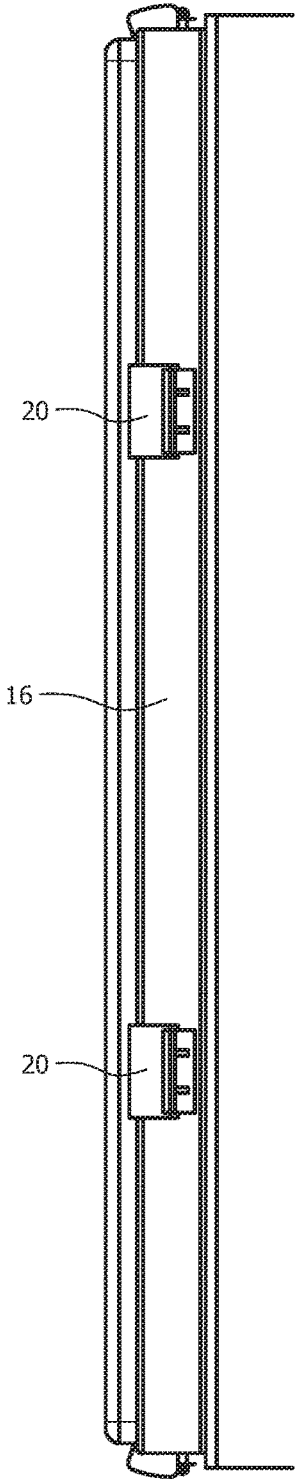

FIG. 2C

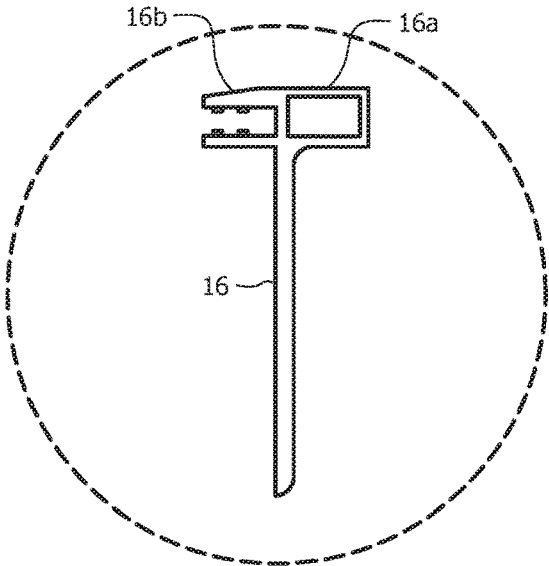
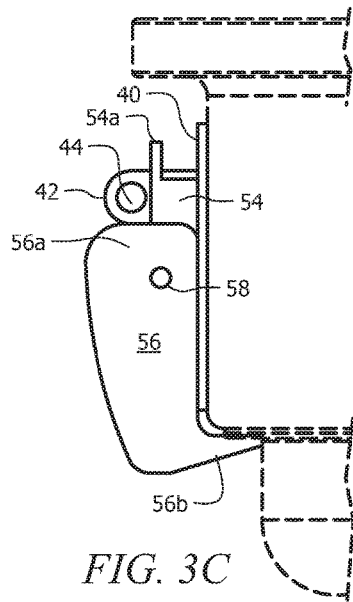
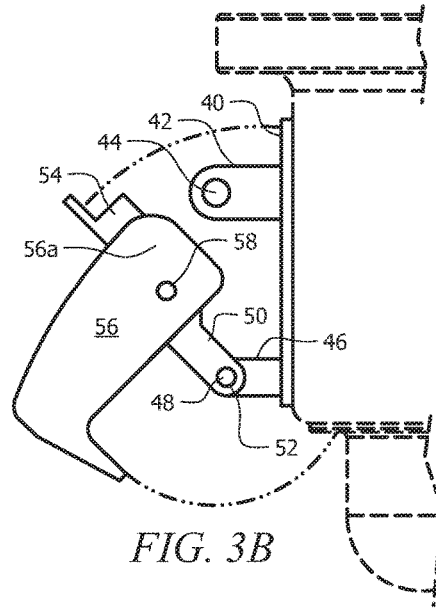
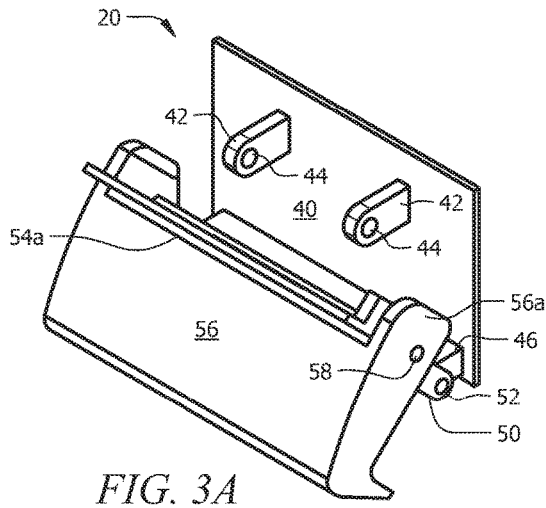
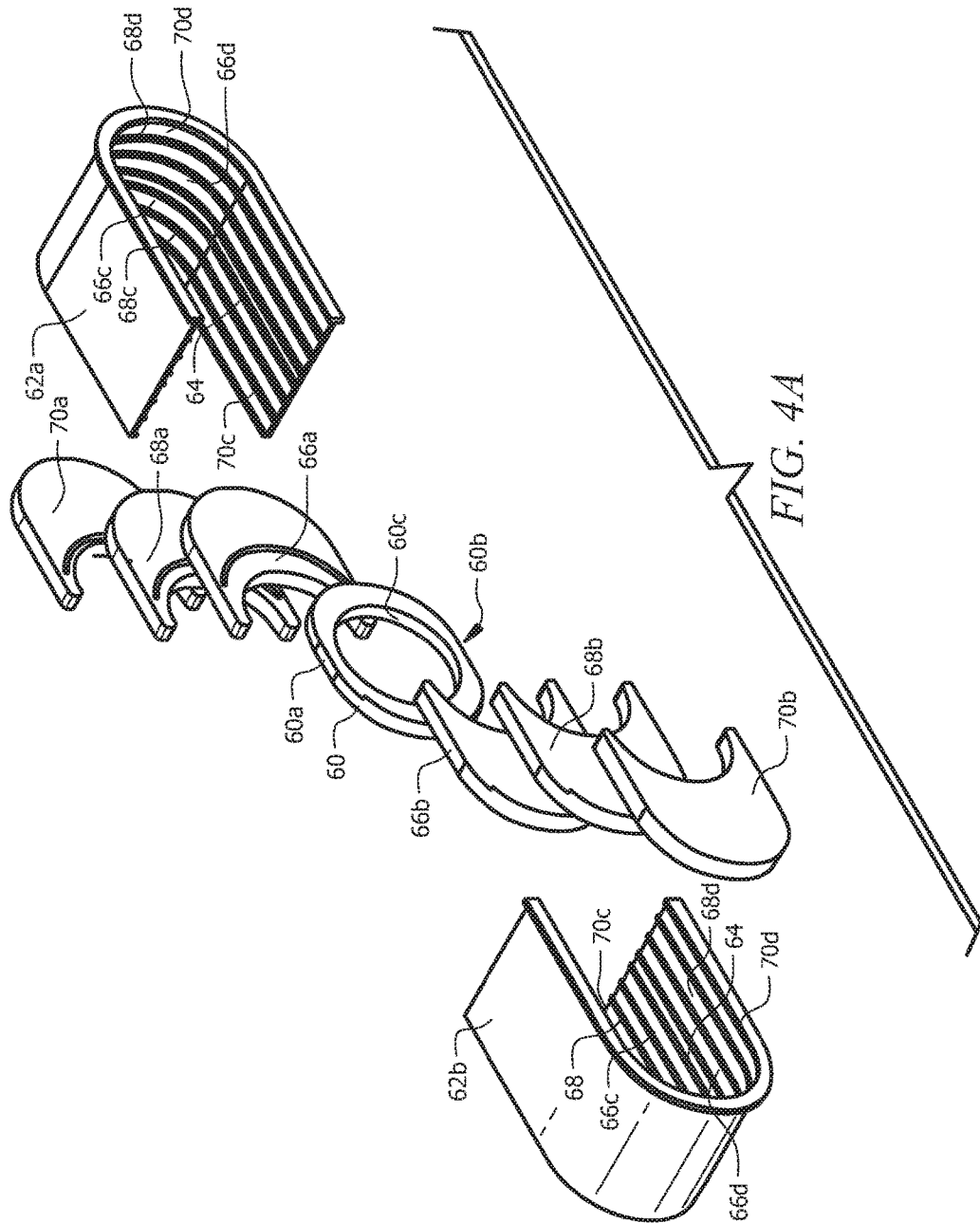
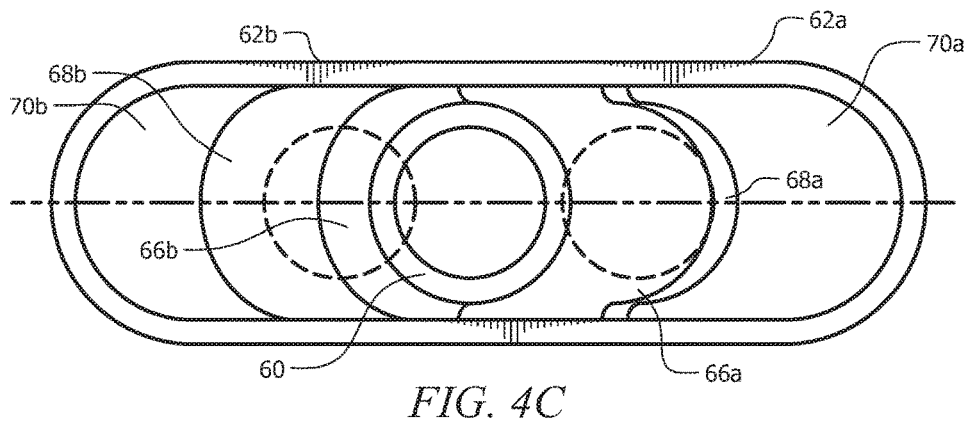
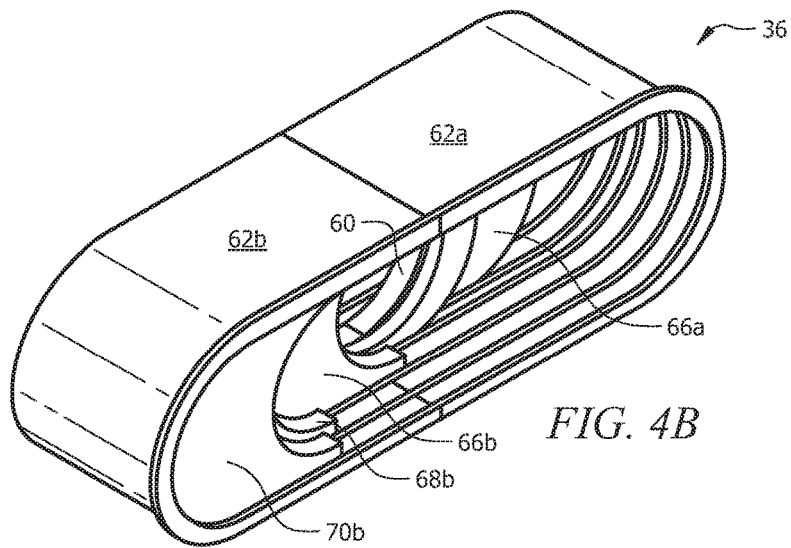

FIG. 2D







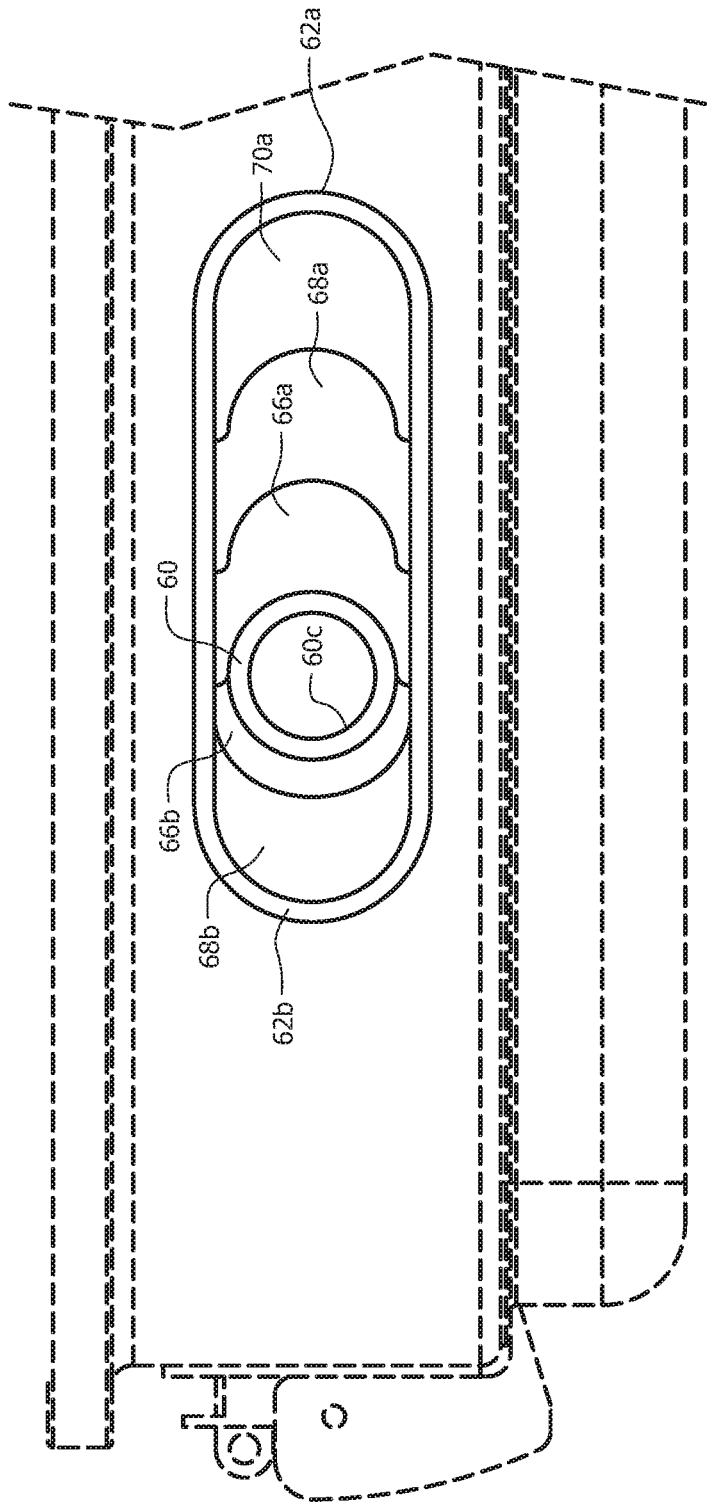

FIG. 4D

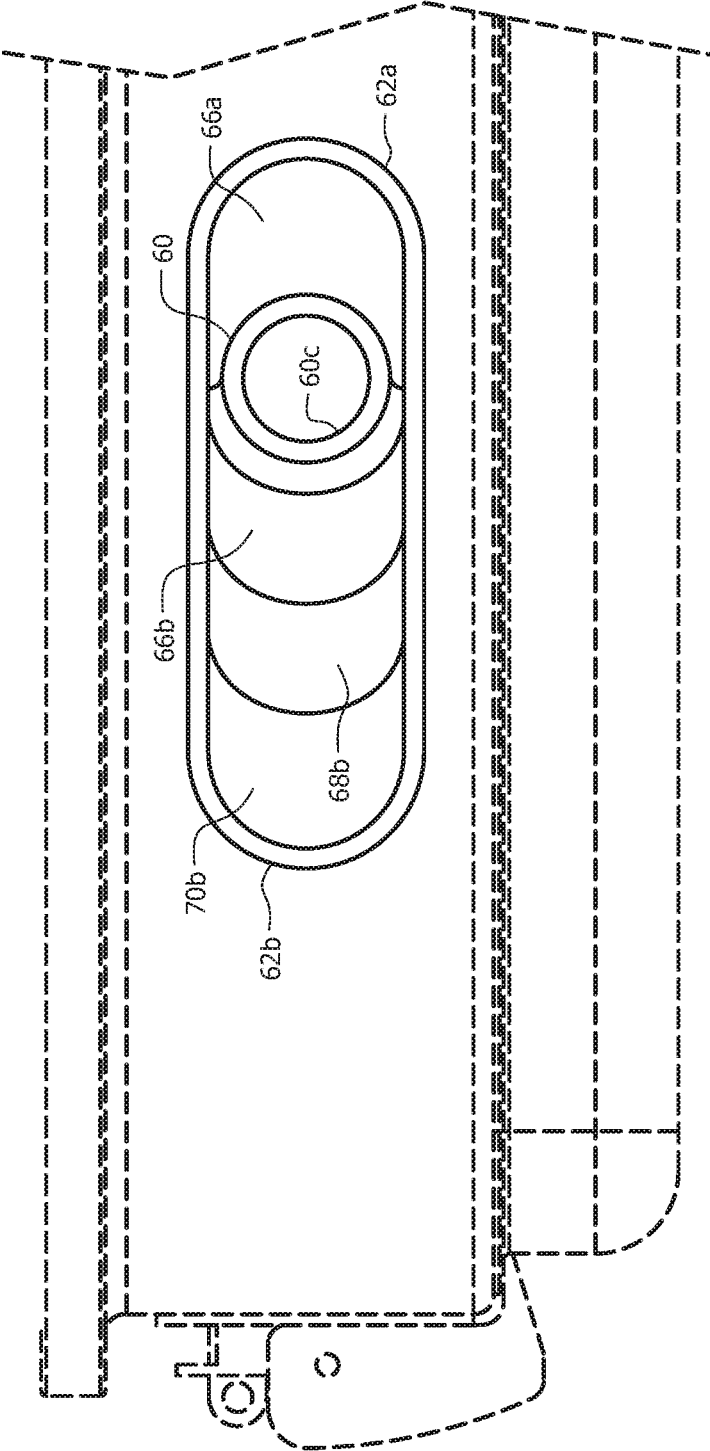

FIG. 4E

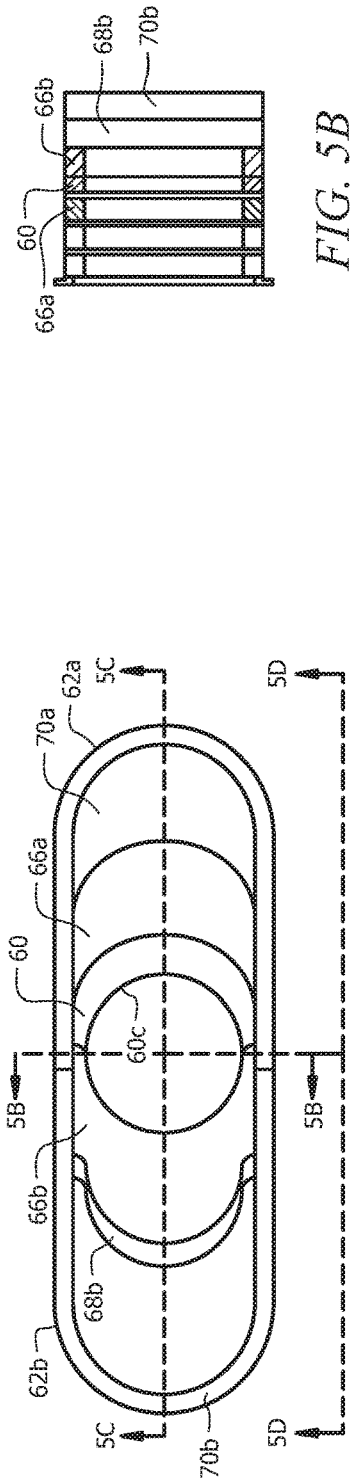

FIG. 5A

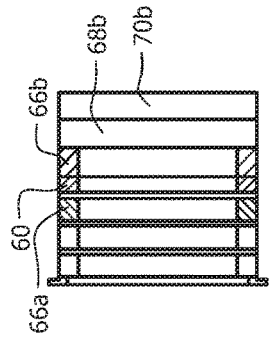

FIG. 5B

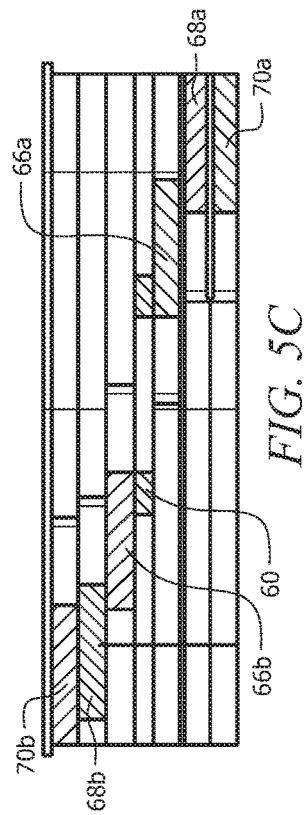

FIG. 5C

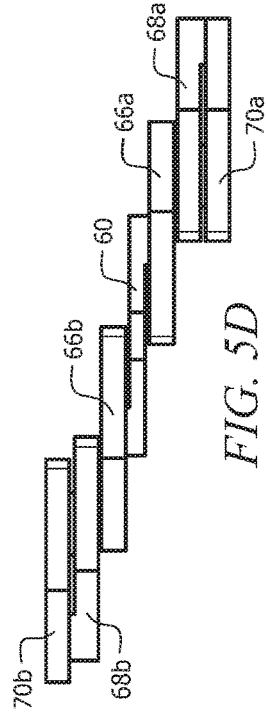

FIG. 5D

1

**EASY-OPENING SOLAR COLLECTOR
HAVING TEMPERATURE-RESPONSIVE
MOUNT FOR POLYMER ABSORBER**

CROSS-REFERENCE TO RELATED
APPLICATIONS

This nonprovisional application is a continuation of and claims priority to provisional application Ser. No. 14/617, 166, entitled "EASY-OPENING SOLAR COLLECTOR HAVING TEMPERATURE-RESPONSIVE MOUNT FOR POLYMER ABSORBER," filed Feb. 9, 2015 by the same inventor.

BACKGROUND OF THE INVENTION

1. Field of the Invention

This invention relates, generally, to solar collectors. More particularly, it relates to solar collector housings that are easily opened and closed without tools. It also relates to solar collectors having polymer absorbers that expand and contract as temperatures rise and fall without placing stress on absorber tubes.

2. Description of the Prior Art

Conventional solar collectors include a cover and a base that are secured to one another by conventional fastening means including screws, nuts, rivets and the like. These fasteners perform well but require the use of tools. Opening and closing such housings cannot be accomplished quickly due to the large numbers of fastening members.

Thus, there is a need for a solar collector housing that can be opened and closed quickly without the use of tools.

Unlike conventional metallic absorbers, polymer absorbers used in some solar collectors are subject to significant length changes due to thermal expansion and contraction. Over the course of a sunny day the absorber may experience temperature swings that may exceed 150° F., resulting in a change in length that may exceed an inch.

Prior art solar collectors mount both ends of the metallic absorber in a fixed position. The greater temperature-responsive expansion and contraction that polymer absorbers experience puts stress on the absorber tubes and eventually causes a leak or total failure. The art of solar collectors has long accepted this problem as being an inherent weakness of polymer absorbers and has responded to the problem by somehow allowing for the length change of polymer absorbers and the absorber tubes as needed.

Thus, there is a need for an improved mounting means for a polymer absorber. The improved mounting means would accommodate the temperature-related expansion and contraction of a polymer absorber but would not make polymer absorber installation more difficult.

However, in view of the prior art considered as a whole at the time the present invention was made, it was not obvious to those of ordinary skill in the art that the use of conventional, tool-requiring fastening members to secure the cover to the base was unacceptable. Nor was it obvious that a better mounting means for the polymer absorber was needed. It follows that the solution to both unperceived problems were not obvious.

SUMMARY OF THE INVENTION

The long-standing but heretofore unfulfilled need for a solar collector housing that can be opened and closed

2

manually, i.e., without tools, and which includes means for accommodating changes in length of the polymer absorber housed within the collector is now met by a new, useful, and non-obvious invention.

5 The novel solar collector includes a housing including a transparent cover, a frame for holding the transparent cover, and a base. The cover, frame and base collectively define a hollow interior within which a polymer absorber is positioned.

10 A plurality of latches is secured to an exterior of the frame about a perimeter of the frame. Each latch has an open configuration and a closed configuration. The frame and base may be separated from one another when the latches are in their respective open configurations and the frame and base may not be separated from one another when the latches are in their respective closed configurations.

15 The latches are opened and closed by hand, i.e., manually, so no tools are required to open and close the housing and the time required to open or close the housing is substantially less than the time required to do so when the housing is closed by conventional fastening members.

20 The frame has a square or rectangular structure formed by a pair of longitudinally extending, transversely spaced apart sidewalls and a pair of transversely disposed, longitudinally spaced apart end walls. The base has a mating structure formed by a pair of longitudinally extending, transversely spaced apart sidewalls and a pair of transversely disposed, longitudinally spaced apart end walls.

25 A first transversely disposed manifold having a hollow interior in open fluid communication with a first end of the absorber tubes is secured to a first end of a polymer absorber. A manifold pipe that is not in fluid communication with the heat transfer liquid fluid in the absorber tubes is integrally formed with each opposed end of the first manifold in axial alignment therewith and such manifold pipes enable pivotal mounting of the cover frame to the base.

30 In an alternative embodiment, instead of providing a manifold pipe at the opposite ends of the first manifold, the first manifold is lengthened to that its opposite ends are outboard of the outermost absorber tubes. In this way, the outermost ends of the first manifold perform the same function as the manifold pipes. Accordingly, reference is hereinafter made to the outermost ends/manifold pipes of the first manifold.

35 An aperture is formed in a first end of each of the sidewalls of the frame and an aperture axially aligned therewith is formed in a first end of each of the sidewalls of the base, i.e., the apertures formed in the frame are in registration with the apertures formed in the base when the cover is in its closed position. The apertures pivotally receive the outermost ends/manifold pipes of the first manifold so that when the latches are in their respective open configurations, the collector is opened or closed by rotating the cover with respect to the frame about said outermost ends/manifold pipes.

40 Each latch has a flat base secured to the sidewalls of the frame and each latch has two primary mounting lugs extending from the flat base in normal relation thereto in lateral relation to one another on opposite sides of a vertical axis of symmetry of the flat base in equidistant relation to the vertical axis of the flat base.

45 An aperture is formed near a distal free end of each primary mounting lug. Each latch also has a second pair of mounting lugs extending from the flat base in normal relation to the flat base and in lateral relation to one another on opposite sides of and in equidistantly spaced relation to a vertical axis of symmetry of the flat base.

An aperture is also formed in the distal free end of each mounting lug of the second pair of mounting lugs.

A latch pull is pivotally connected at a first end to each mounting lug of the second pair of mounting lugs. The latch pull has a preselected length so that a second end of the latch pull abuts the flat base adjacent each primary mounting lug when the latch pull is pivoted from its open configuration to its closed configuration.

The latch pull has a thickness less than an extent of each primary mounting lug so that when the latch pull abuttingly engages the flat base, the apertures formed in the primary mounting lugs are adapted to receive a pin therethrough to prevent reverse pivoting of each latch pull.

A first end of the latch catch is pivotally mounted to an associated latch pull. The latch pull and latch catch are positioned in angular relation to one another when the latch catch is in its open configuration and when the latch pull is rotated from its open position to its closed position.

A second end of said latch catch engages and retains the base, thereby securing the cover to the base when the latch pull abuts the flat base of the latch.

A second transversely disposed manifold having a hollow interior in fluid communication with the absorber tubes is secured to a second end of the polymer absorber and a second manifold pipe is secured to the opposite ends of said second manifold. Like the manifold pipes at the first end of the polymer absorber, the manifold pipes at the second end of the polymer absorber are integrally formed with and in axial alignment with the second manifold but are not in fluid communication with the absorber tubes, i.e., the heat transfer liquid fluid in the absorber tubes does not flow into said manifold pipes.

However, it is also within the scope of this invention to use the opposite ends of the second manifold as manifold pipes and in such event the opposite ends of the second manifold extend outboard of the outermost absorber tubes. Accordingly, the respective opposite ends of the first and second manifolds are referred to as opposite ends/manifold pipes. In the claims that follow, reference to outermost ends shall be interpreted as including outermost ends of a manifold or to a manifold pipe attached to each outermost end.

A longitudinally-extending slot is formed in a second end of each of the sidewalls of said frame, there being a pair of transversely spaced apart slots in said second end of said frame. A longitudinally-extending slot is formed in a second end of each of the sidewalls of the base as well, there being a pair of transversely spaced apart slots in the second end of the base.

The respective pairs of slots formed in the frame and the base are in registration with one another. A variable gate closure component (VGC component) is positioned within both of the pairs of slots, there being two VGC components in transversely spaced apart relation to one another. The VGC components respectively receive the opposite ends/manifold pipes of the second manifold.

Each VGC component includes a flat, generally circular grommet having a flat formed in a top edge and a bottom edge, and having an aperture formed centrally thereof. The opposite ends/manifold pipes of the second manifold are disposed in engaged relation to an associated central aperture.

The VGC component includes an elongate frame having a generally oblong configuration. A plurality of parallel guide tracks is formed in an interior surface of the elongate VGC component frame. The plurality of guide tracks includes a center guide track that slideably receives the

grommet. The grommet slides in its track in response to expansion or contraction of the polymer absorber.

A pair of interior guide tracks is formed in the interior surface on opposite, outboard sides of the center guide track and an interior panel is slideably received within both of the interior guide tracks.

Each interior panel of the pair of interior panels has a generally C-shaped structure and has flats formed in their respective top and bottom edges. The flats slideably engage their respective guide tracks and are displaced when the grommet is displaced.

The plurality of guide tracks further includes a pair of middle guide tracks formed in the interior surface of the VGC component frame on opposite, outboard sides of the interior guide tracks in parallel relation to the center tracks and to said interior tracks.

A pair of middle panels is slideably received within the middle guide tracks. Each middle panel of the pair of middle panels has a generally C-shaped structure and has flats formed in their respective top and bottom edges. The flats slideably engage their respective guide tracks and are displaced when the interior panels are displaced due to displacement of the grommet.

The plurality of guide tracks further includes a pair of exterior or outer guide tracks formed in the interior surface of the VGC component frame on opposite, outboard sides of the middle guide tracks. A pair of exterior or outer panels is slideably received within the exterior guide tracks. Each exterior panel of the pair of exterior panels has a generally C-shaped structure and has flats formed in their respective top and bottom edges. The flats slideably engage their respective guide tracks and are displaced when the middle panels are displaced.

It should therefore be understood that the grommet engages the interior panels so that said interior panels slide when the grommet slides, the interior panels engage the middle panels so that said middle panels slide when the interior panels slide, and said middle panels engage the exterior panels so that said exterior panels slide when the middle panels slide. Outside or ambient air therefore cannot enter into the slots occupied by the VGC component. The grommet of the VGC component moves conjointly with the polymer absorber as said polymer absorber lengthens and shortens, thereby eliminating stress on the absorber tubes.

An important object of the invention is to provide a solar collector housing that can be opened and closed quickly and easily by one person in the absence of tools.

A more specific object is to facilitate the opening and closing of the collector by providing manually-operated latches that are secured about the periphery of the frame that holds the transparent cover, which enable opening of the cover when in an open configuration and which secure the cover to the base when the collector is closed.

Another important object is to remove the stress from absorber tubes by attaching one end of the polymer absorber to a grommet that slides in a guide track in response to temperature-responsive expansions and contractions of the polymer absorber.

A closely related object is to provide panels that slide with the grommet so that ambient air cannot enter into the collector housing as the grommet slides.

These and other important objects, advantages, and features of the invention will become clear as this disclosure proceeds.

The invention accordingly comprises the features of construction, combination of elements, and arrangement of parts

that will be exemplified in the disclosure set forth hereinafter and the scope of the invention will be indicated in the claims.

BRIEF DESCRIPTION OF THE DRAWINGS

For a fuller understanding of the nature and objects of the invention, reference should be made to the following detailed disclosure, taken in connection with the accompanying drawings, in which:

FIG. 1 is an exploded perspective view of the novel collector;

FIG. 2A is a plan view of the cover;

FIG. 2B is a front elevation view of the cover;

FIG. 2C is an end elevation view of the cover;

FIG. 2D is an enlarged view of the circled area of FIG. 2A;

FIG. 3A is a perspective view of the novel frame latch;

FIG. 3B is a side elevation view depicting the frame latch in an open configuration;

FIG. 3C is a side elevation view depicting the frame latch in its closed configuration;

FIG. 4A is an exploded perspective view of the novel VGC component;

FIG. 4B is a perspective view of an assembled VGC component;

FIG. 4C is a side elevation view of an assembled VGC component when the grommet is in its centered retracted position;

FIG. 4D is a side elevation view of an assembled VGC component when the center of the grommet is in its fully extended position;

FIG. 4E is a side elevation view of an assembled VGC component when the center of the grommet is in its fully retracted position;

FIG. 5A is a side elevation view of the novel VGC component;

FIG. 5B is a sectional view taken along FIG. 5B-5B in FIG. 5A;

FIG. 5C is a sectional view taken along line 5C-5C in FIG. 5A; and

FIG. 5D is a plan view taken along line 5D-5D in FIG. 5A.

DETAILED DESCRIPTION OF THE PREFERRED EMBODIMENT

FIG. 1 is an exploded view of an illustrative embodiment of the novel structure, denoted as a whole by the reference numeral 10.

Solar collector 10 has a conventional rectangular shape. Cover 12 of collector 10 includes glazed glass or other suitable transparent material 14 which is mounted in frame 16. Base 18 is an aluminum skinned formed foam box which underlies cover 12 and is secured to said cover by a plurality of novel latches, collectively denoted 20, which are secured to said frame 16. As depicted, each end of frame 16 has a pair of the novel latches secured thereto, preferably disposed on opposite sides of the longitudinal axis of symmetry of frame 16 in equidistant relation thereto. Each side of frame 16 also has a pair of the novel latches, preferably disposed on opposite sides of the transverse axis of symmetry of frame 16 in equidistant relation thereto.

Polymer absorber 22 is positioned in an interior space that is formed by connecting cover 12 to base 18. A first transversely disposed manifold 24 is secured to a first end of polymer absorber 12. Manifold pipe 26 is secured to the opposite ends of the first manifold in axial alignment there-

with, it being understood that one manifold pipe is obscured in said Figure. In the alternative, first manifold 24 is lengthened so that its opposite ends extend beyond, i.e., outboard of the outermost absorber tubes in the polymer absorber and said opposite ends perform the same functions as manifold pipes 26.

Opening 18a is formed in cover frame 16 and in base 18 at a leading end thereof as depicted in FIGS. 1 and 2B and said opening pivotally receives a first end of outermost end/manifold pipe 26. The pivotal connection is secured by grommet 28. A second opening 18a is formed in base 18 in transversely opposed relation to the depicted opening 18a in FIG. 1 and is obscured by cover 12. That second opening pivotally receives the opposite end of outermost end/manifold pipe 26 and a second grommet secures that connection.

Second manifold 30 is mounted to the opposite end of polymer absorber 22 and it has the same structure as first manifold 24, i.e., it may have a manifold pipe 32 secured to its opposite ends or it may be lengthened so that its opposite ends extend outboard of the outermost absorber tubes so that said opposite ends perform the same function as such manifold pipes.

Elongate slots 34, 34 are formed in base 18 near its trailing end. Each opposite end/manifold pipe of second manifold 30 is engaged by a novel device referred to herein as a variable gate closure or VGC component 36.

FIGS. 2A, 2B and 2C provide plan, side, and end views of cover 12. FIG. 2D is an enlarged view of the circled corner in FIG. 2A. It discloses that the outer border of frame 16 has a box-like frame 16a and the inner border 16b thereof has two vertically spaced apart projections that receive glazed glass or other suitable transparent material 14 between them. Each projection has glaze-engaging teeth formed in it to enhance its grip on the outer edge or border of said glazed glass 14.

FIG. 3A depicts a latch 20 in perspective view. Flat base 40 is secured to sidewalls 16 of cover 12. Two (2) mounting lugs, collectively denoted 42, extend from base 40 in normal relation thereto in lateral relation to one another on opposite sides of a vertical axis of symmetry of said latch 20, in equidistant relation to said vertical axis. An aperture 44 is formed near the distal free end of each mounting lug. Each mounting lug is flat and has a vertical axis parallel to the vertical axis of symmetry of latch 20. As used herein, terms such as "vertical" and "horizontal" refer to a solar collector 10 disposed in a horizontal plane on a flat roof so that sidewalls 16 thereof are in a vertical plane.

Two (2) further mounting lugs are collectively denoted 46 although only one (1) of them can be seen in FIGS. 3A-C. Lugs 46 are also flat and they also extend from flat base 40 in normal relation to said flat base in lateral relation to one another on opposite sides of and in equidistantly spaced relation to a vertical axis of symmetry of said flat base, but they are preferably spaced further from one another than are mounting lugs 42, 42. An aperture 48 (depicted in FIGS. 3A and 3B but labeled only in FIG. 3B to avoid cluttering the drawings) is formed in the distal free end of each mounting lug 46.

A latch pull 50 is pivotally connected at a first end by a pivot pin to each mounting lug 46 as at 52 on the outboard side thereof. Latch pull 50 is formed of a rigid material and its length is preselected so that second end 54 thereof abuts flat base 40 on the outboard side of each mounting lug 42, 42 when latch pull is pivoted about pivot pin 52 from its FIG. 3A or FIG. 3B position to its FIG. 3C position.

Latch pull 50 has a thickness less than the extent of each mounting lug 42, 42 so that when said latch pull 50

abuttingly engages flat base **40**, apertures **44**, **44** formed in said mounting lugs are clear. A clevis pin, not depicted, or other suitable locking means is then inserted through each aperture **44**, **44**, preventing reverse pivoting of each latch pull **50**.

Latch catch **56** is also formed of a rigid material and has a lateral extent slightly greater than the lateral spacing between mounting lugs **46**, **46** so that its opposite end is positioned outboard of said mounting lugs **46**, **46**. A first end **56a** of latch catch **56** is pivotally mounted as at **58** to each latch pull **50**, **50** about midway between ends **52** and **54** of said latch pull. Latch pull **50** and latch catch **56** are positioned roughly normal to one another when latch catch **56** is in its open configuration as depicted in FIGS. **3A** and **3B**. When latch pull **50** is rotated from its open position of FIGS. **3A** and **3B** to its closed position of FIG. **3C**, latch pull **50** and latch catch **56** remain in their respective, mutually normal positions.

After latch pull **50** abuts flat base **16** and a clevis pin or the like is inserted into each aperture **44** to prevent reverse rotation, latch catch **56** is then rotated from its open configuration of FIGS. **3A** and **3B** into its closed position of FIG. **3C**. Second end **56b** of latch catch **56** then engages and retains base/aluminum skinned formed foam box **18**, thereby securing said base **18** to cover **12**. This enables the locking procedure of all six (6) latches **20** to be performed by one (1) installer in just a few moments. Collectors of differing sizes may have more or fewer latches but in all cases the novel locking procedure is much faster than the locking procedures of the prior art.

Projection **54a** at the upper end **54** of latch pull **50** provides a finger-engageable part that facilitates opening of latch **20** when the undepicted locking pin/clevis pin is removed. Such pin is not removed until after second end **56b** of latch catch **56** is rotated away from its engagement with base **18**.

Variable gate closure or VGC component **36** is depicted in FIGS. **4A-4E** and in FIGS. **5A-5D**. In view of the temperature-related changes in length that a polymer absorber undergoes, a first end of the absorber needs to have a fixed position while a second end needs freedom to move longitudinally. VGC component **36** moves with the second end of the polymer absorber while keeping the inside of the collector enclosure isolated from outside air.

As best understood in the exploded perspective view of FIG. **4A** and in the assembled perspective view of FIG. **4B**, VGC component **36** includes grommet **60** which is flat and generally circular but with a flat formed in its top edge **60a** and its bottom edge **60b**, and which has aperture **60c** formed centrally thereof. Aperture **60c** engages the opposite ends/manifold pipes **32** of second manifold **30** when novel collector housing **10** is fully assembled.

In this preferred embodiment, seven (7) grooves or guide tracks are formed on the inner surface of each part of confronting frame parts **62a**, **62b**. Center guide track **64** is slightly narrower than the other guide tracks and slideably receives grommet **60** when said parts **62a**, **62b** abut one another as depicted in FIGS. **4A** and **4B**.

Grommet **60** is flanked by and engages a pair of interior panels **66a**, **66b** which are slideably received within interior guide tracks **66c**, **66d**, respectively, when VGC component **36** is fully assembled.

Interior panels **66a**, **66b** are flanked by and engage a pair of middle panels **68a**, **68b** which are slideably received within middle guide tracks **68c**, **68d**, respectively, when VGC component **36** is fully assembled.

Middle panels **68a**, **68b** are flanked by and engage a pair of outer panels **70a**, **70b** which are slideably received within outer guide tracks **70c**, **70d**, respectively, when VGC component **36** is fully assembled.

The interior, middle and outer panels are generally C-shaped and have flats formed in their respective top and bottom edges, just as in grommet **60**. The flats are not numbered to avoid clutter. They slideably engage their respective guide tracks when grommet **60** slides in central guide track **64**.

Each grommet **60** is free to slide in its central guide track **64** when an installer places the outermost ends/manifold pipes **32**, **32** of second manifold **30** in apertures **60c**, **60c** while installing polymer absorber **22**.

FIG. **4C** depicts the central position of grommet **60** where it is centered in VGC component **36**, i.e., when the polymer absorber is in a position of repose, i.e., neither extended nor contracted.

FIG. **4D** depicts the fully extended position of grommet **60** where it has slid in its guide track towards the second end of collector **10** due to temperature-related expansion of the polymer absorber.

FIG. **4E** depicts the fully retracted position of grommet **60** where it has slid in its guide track towards the first end of collector **10** due to temperature-related contraction of the polymer absorber.

In the preferred embodiment, grommet **60** can slide about three-quarters of an inch in either direction from its central position but other distances are within the scope of this invention, i.e., differing polymer absorbers may have differing ranges between full extension and full retraction.

FIGS. **5A-D** depict the same parts disclosed in connection with the disclosure of FIGS. **4A-E**. FIGS. **5A-D** depict VGC component structure **36** when grommet **60** is slightly to the right of the center of said VGC component, said center being where parts **62a**, **62b** meet. The respective positions of the interior, middle, and exterior panels are depicted in FIG. **5A** but those positions are best understood when comparing FIG. **5A** with FIGS. **5B-D**. For example, middle panel **68a** is obscured in FIG. **5A** by exterior panel **70a** as depicted in FIG. **5C**.

It should therefore be understood that grommet **60** engages interior panels **66a**, **66b** so that said interior panels slide when the grommet slides, the interior panels engage middle panels **68a**, **68b** so that said middle panels slide when the interior panels slide, and said middle panels engage exterior panels **70a**, **70b** so that said exterior panels slide when the middle panels slide. Outside or ambient air therefore cannot enter into the slots occupied by VGC component **36**. Grommet **60** moves conjointly with the polymer absorber as said polymer absorber lengthens and shortens, thereby eliminating stress on the absorber tubes.

It will thus be seen that the objects set forth above, and those made apparent from the foregoing disclosure, are efficiently attained and since certain changes may be made in the above construction without departing from the scope of the invention, it is intended that all matters contained in the foregoing disclosure or shown in the accompanying drawings shall be interpreted as illustrative and not in a limiting sense.

It is also to be understood that the following claims are intended to cover all of the generic and specific features of the invention herein disclosed, and all statements of the scope of the invention that, as a matter of language, might be said to fall therebetween.

What is claimed is:

1. A solar collector, comprising:
 a housing having a hollow interior;
 said housing including a transparent cover, a frame for
 holding said transparent cover, and a base; 5
 a polymer absorber disposed within said hollow interior
 between said transparent cover and said base;
 a plurality of latches secured to an exterior of said frame
 about a perimeter thereof;
 each latch of said plurality of latches having an open 10
 configuration and a closed configuration, said frame
 and base being at least partially unconnected to one
 another when one or more of said plurality of latches
 are in said open configuration and said frame and base
 being connected to one another when each of said 15
 latches are in said closed configuration;
 whereby said housing is opened and closed in the absence
 of tools;
 said frame having sidewalls;
 said base having sidewalls; 20
 said frame pivotally secured to the base through a first
 manifold pipe extending between apertures formed in
 said sidewalls of said frame and base; and
 whereby when said latches are in their respective open
 configurations, said collector is opened or closed by 25
 rotating said frame with respect to said base about said
 first manifold pipe.

2. The solar collector of claim **1**, further comprising:
 said frame having a square or rectangular structure
 formed by said sidewalls, wherein said sidewalls 30
 include a pair of longitudinally extending, transversely
 spaced apart sidewalls and a pair of transversely dis-
 posed, longitudinally spaced apart end walls; and
 said base having a mating structure formed by said
 sidewalls, wherein said sidewalls include a pair of 35
 longitudinally extending, transversely spaced apart
 sidewalls and a pair of transversely disposed, longitu-
 dinally spaced apart end walls.

3. The solar collector of claim **2**, further comprising:
 each latch of said plurality of latches having a flat base 40
 secured to said sidewalls of said frame;
 each latch having two mounting lugs extending from said
 flat base in normal relation thereto in lateral relation to
 one another on opposite sides of a vertical axis of
 symmetry of said flat base in equidistant relation to said 45
 vertical axis;
 an aperture formed near a distal free end of each mounting
 lug;
 each latch having further mounting lugs extending from
 said flat base in normal relation to said flat base in 50
 lateral relation to one another on opposite sides of and
 in equidistantly spaced relation to a vertical axis of
 symmetry of said flat base;
 an aperture formed in the distal free end of each further
 mounting lug; 55
 a latch pull pivotally connected at a first end to each
 further mounting lug, said latch pull having a prese-
 lected length so that a second end of said latch pull
 abuts said flat base adjacent each mounting lug when
 said latch pull is pivoted from said open configuration 60
 to said closed configuration; and
 said latch pull having a thickness less than an extent of
 each mounting lug so that when said latch pull abut-
 tingly engages said flat base, said apertures formed in
 said mounting lugs are adapted to receive a pin there- 65
 through, said pin preventing reverse pivoting of each
 latch pull.

4. The solar collector of claim **3**, further comprising:
 a first end said latch catch being pivotally mounted to an
 associated latch pull;
 said latch pull and latch catch being positioned in angular
 relation to one another when said latch catch is in its
 open configuration and when said latch pull is rotated
 from said open position to said closed position; and
 said second end of said latch catch engaging and retaining
 said base, thereby securing said cover to said base when
 said latch pull abuts said flat base of said latch.

5. The solar collector of claim **2**, further comprising:
 a second transversely disposed manifold secured to a
 second end of polymer absorber;
 a longitudinally-extending slot formed in a second end of
 each of said sidewalls of said frame, there being a pair
 of transversely spaced apart slots in said second end of
 said frame;
 a longitudinally-extending slot formed in a second end of
 each of said sidewalls of said base, there being a pair
 of transversely spaced apart slots in said second end of
 said base;
 said pairs of slots formed in said frame and base being in
 registration with one another;
 a variable gate closure component positioned within both
 of said pairs of slots, there being two variable gate
 closure components in transversely spaced apart rela-
 tion to one another; and
 each of said variable gate closure components receiving
 an end of said second manifold.

6. The solar collector of claim **5**, further comprising:
 said variable gate closure including a flat, generally
 circular grommet having a flat formed in a top edge a
 bottom edge, and having an aperture formed centrally
 thereof; and
 said aperture disposed in engaged relation to an associated
 end of said second manifold when said solar collector
 is fully assembled.

7. The solar collector of claim **6**, further comprising:
 said variable gate closure component including an elon-
 gate frame having a generally oblong configuration;
 a plurality of guide tracks formed in an interior surface of
 said elongate frame;
 said plurality of guide tracks including a center guide
 track that slideably receives said grommet;
 said plurality of guide tracks including at least a pair of
 interior guide tracks formed in said interior surface on
 opposite, outboard sides of said center guide track;
 an interior panel slideably received within each of said
 interior guide tracks; and
 each interior panel of said pair of interior panels having a
 generally C-shaped structure and having flats formed in
 their respective top and bottom edges, said flats slide-
 ably engaging their respective guide tracks and being
 displaced when said grommet is displaced.

8. The solar collector of claim **7**, further comprising:
 said plurality of guide tracks further including at least a
 pair of middle guide tracks formed in said interior
 surface on opposite, outboard sides of said interior
 guide tracks;
 a pair of middle panels slideably received within said
 middle guide tracks; and
 each middle panel of said pair of middle panels having a
 generally C-shaped structure and having flats formed in
 their respective top and bottom edges, said flats slide-
 ably engaging their respective guide tracks and being
 displaced when said interior panels are displaced.

11

9. The solar collector of claim 8, further comprising:
 said plurality of guide tracks further including at least a
 pair of exterior guide tracks formed in said interior
 surface on opposite, outboard sides of said middle
 guide tracks;
 a pair of exterior panels slideably received within said
 exterior guide tracks; and
 each exterior panel of said pair of exterior panels having
 a generally C-shaped structure and having flats formed
 in their respective top and bottom edges, said flats
 slideably engaging their respective guide tracks and
 being displaced when said middle panels are displaced.
 10. A solar collector, comprising:
 a housing having a hollow interior;
 said housing including a cover, a frame for holding said
 cover, and a base;
 a polymer absorber disposed within said hollow interior
 between said cover and said base;
 said frame having a square or rectangular structure
 formed by a pair of longitudinally extending, trans-
 versely spaced apart sidewalls and a pair of trans-
 versely disposed, longitudinally spaced apart end walls;
 said base pivotally secured to said frame through a first
 manifold pipe extending from a first manifold, the first
 manifold pipe being pivotally received at both ends by
 said base and said frame; and
 whereby when said latches are in their respective open
 configurations, said collector is opened or closed by
 rotating said frame with respect to said base about said
 first manifold pipe.
 11. The solar collector of claim 10, further comprising:
 said frame having a square or rectangular structure
 formed by a pair of longitudinally extending, trans-
 versely spaced apart sidewalls and a pair of trans-
 versely disposed, longitudinally spaced apart end walls;
 said base having a mating structure formed by a pair of
 longitudinally extending, transversely spaced apart
 sidewalls and a pair of transversely disposed, longitu-
 dinally spaced apart end walls;
 said first manifold transversely secured to a first end of
 said polymer absorber;
 an aperture formed in a first end of each of said sidewalls
 of said frame;
 an aperture formed in a first end of each of said sidewalls
 of said base;
 said apertures formed in said frame and base being in
 open registration with one another; and
 said apertures pivotally receiving opposite ends of said
 first manifold pipe.
 12. The solar collector of claim 11, further comprising:
 a second transversely disposed manifold secured to a
 second end of polymer absorber;
 a longitudinally-extending slot formed in a second end of
 each of said sidewalls of said frame, there being a pair
 of transversely spaced apart slots in said second end of
 said frame;
 a longitudinally-extending slot formed in a second end of
 each of said sidewalls of said base, there being a pair
 of transversely spaced apart slots in said second end of
 said base;

12

said pairs of slots formed in said frame and base being in
 registration with one another;
 a variable gate closure component positioned within each
 of said pairs of slots, there being two variable gate
 closure components in transversely spaced apart rela-
 tion to one another; and
 each of said variable gate closure components receiving
 an associated end of said second manifold.
 13. The solar collector of claim 12, further comprising:
 said variable gate closure including a flat, generally
 circular grommet having a flat formed in a top edge a
 bottom edge, and having an aperture formed centrally
 thereof; and
 said aperture disposed in engaged relation to an associated
 end of said second manifold when said solar collector
 is fully assembled.
 14. The solar collector of claim 13, further comprising:
 said variable gate closure component including an elon-
 gate frame having a generally oblong configuration;
 a plurality of guide tracks formed in an interior surface of
 said elongate frame;
 said plurality of guide tracks including a center guide
 track that slideably receives said grommet;
 said plurality of guide tracks including at least a pair of
 interior guide tracks formed in said interior surface on
 opposite, outboard sides of said center guide track;
 an interior panel slideably received within each of said
 interior guide tracks; and
 each interior panel of said pair of interior panels having a
 generally C-shaped structure and having flats formed in
 their respective top and bottom edges, said flats slide-
 ably engaging their respective guide tracks and being
 displaced when said grommet is displaced.
 15. The solar collector of claim 14, further comprising:
 said plurality of guide tracks further including at least a
 pair of middle guide tracks formed in said interior
 surface on opposite, outboard sides of said interior
 guide tracks;
 a pair of middle panels slideably received within said
 middle guide tracks; and
 each middle panel of said pair of middle panels having a
 generally C-shaped structure and having flats formed in
 their respective top and bottom edges, said flats slide-
 ably engaging their respective guide tracks and being
 displaced when said interior panels are displaced.
 16. The solar collector of claim 14, further comprising:
 said plurality of guide tracks further including at least a
 pair of exterior guide tracks formed in said interior
 surface on opposite, outboard sides of said middle
 guide tracks;
 a pair of exterior panels slideably received within said
 exterior guide tracks; and
 each exterior panel of said pair of exterior panels having
 a generally C-shaped structure and having flats formed
 in their respective top and bottom edges, said flats
 slideably engaging their respective guide tracks and
 being displaced when said middle panels are displaced.

* * * * *