



(19) **United States**

(12) **Patent Application Publication**
MUKHERJEE

(10) **Pub. No.: US 2017/0363673 A1**

(43) **Pub. Date: Dec. 21, 2017**

(54) **WIRELESS MECHANISM FOR DETECTING AN OPEN OR CLOSED CONTAINER, AND METHODS OF MAKING AND USING THE SAME**

(52) **U.S. Cl.**
CPC **G01R 31/026** (2013.01); **B65D 79/02** (2013.01); **G01N 27/025** (2013.01)

(71) Applicant: **Thin Film Electronics ASA, Oslo (NO)**

(57) **ABSTRACT**

(72) Inventor: **Somnath MUKHERJEE, Milpitas, CA (US)**

(21) Appl. No.: **15/626,512**

(22) Filed: **Jun. 19, 2017**

An electronic device including a continuity sensor and electrical circuitry configured to detect and report the continuity state of an article, container or product packaging is disclosed. The continuity sensor includes a first substrate with first and second coils thereon, and a second substrate with a third coil thereon. The first coil has an integrated circuit electrically connected thereto. The first substrate is part of, or is attached or secured to a part of the article, container or packaging. The second substrate is another part of, or is attached or secured to another part of the article, container or packaging. One of the article, container or packaging parts is (re)movable with respect to the other part. The first and second coils have one coupling when the article, container or packaging is closed or sealed, and a different coupling when the article, container or packaging is open or unsealed.

Related U.S. Application Data

(60) Provisional application No. 62/351,875, filed on Jun. 17, 2016.

Publication Classification

(51) **Int. Cl.**
G01R 31/02 (2006.01)
G01N 27/02 (2006.01)
B65D 79/02 (2006.01)

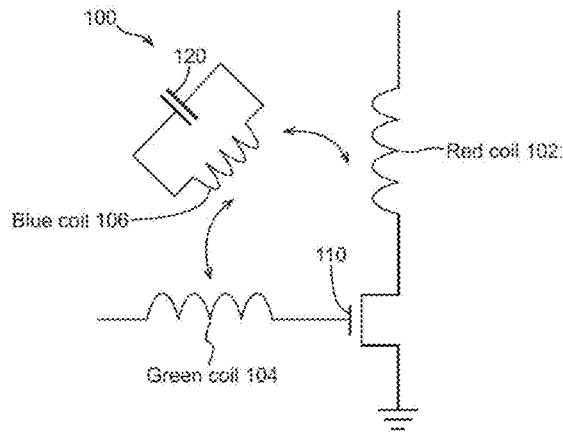

FIG. 2A

FIG. 2B

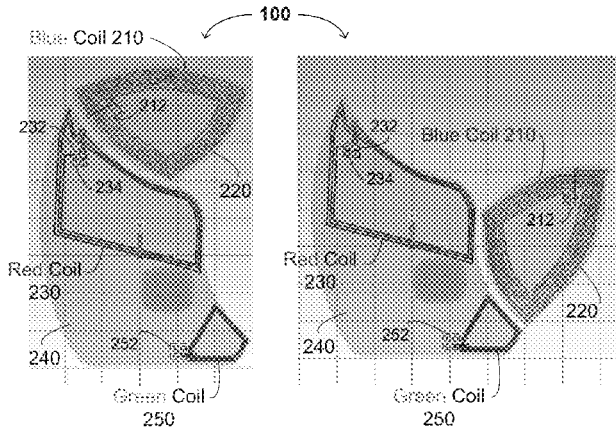

FIG. 1

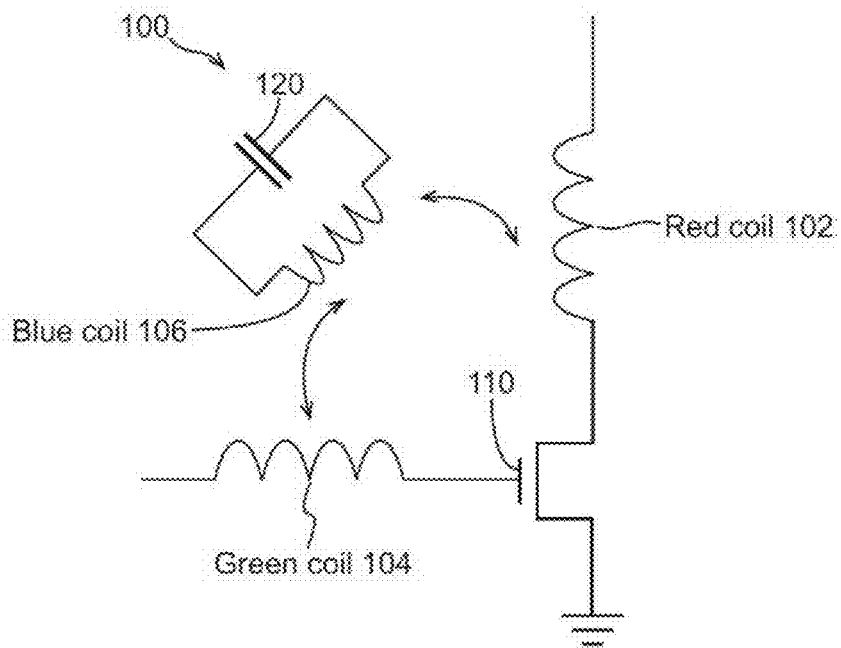

FIG. 2A

FIG. 2B

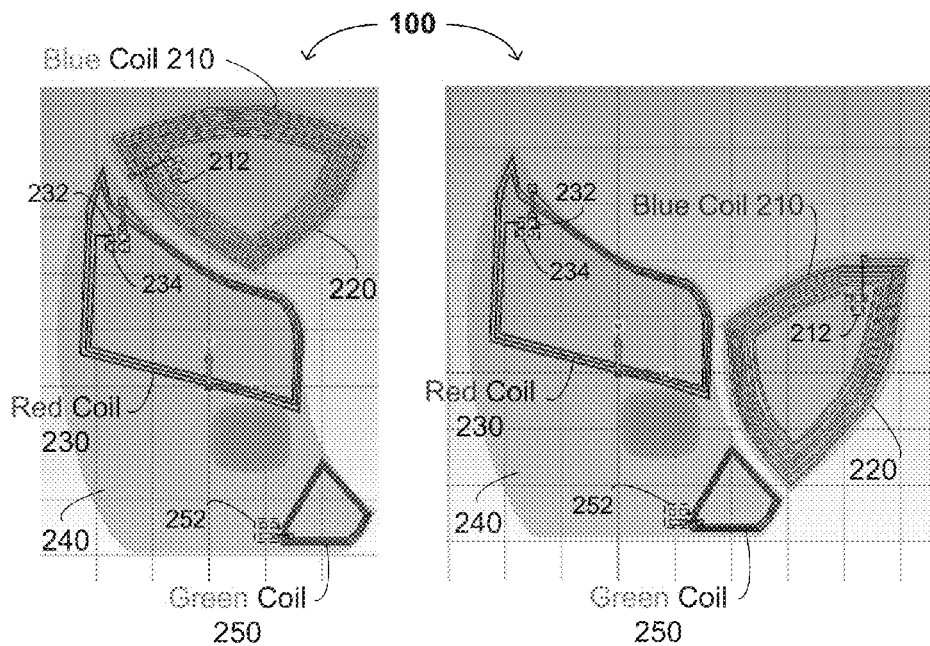

FIG. 3A

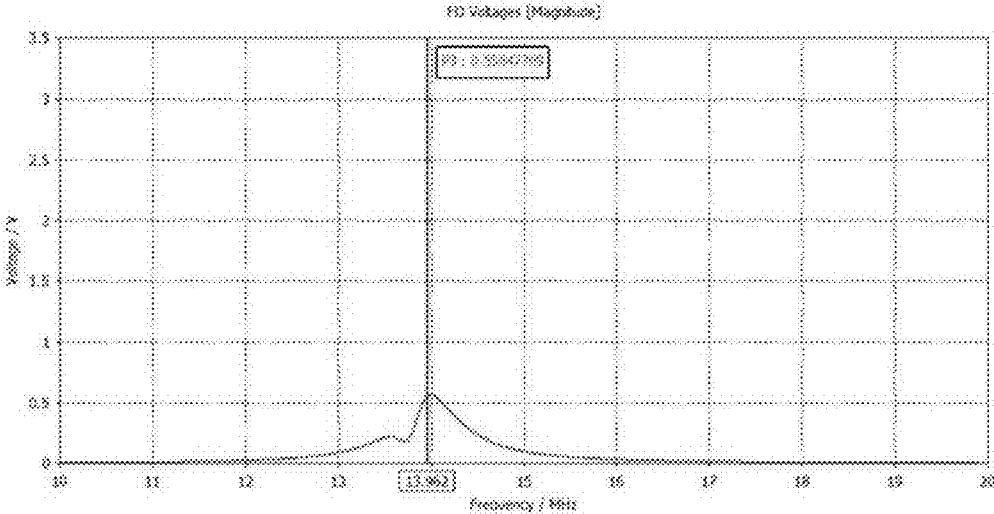

FIG. 3B

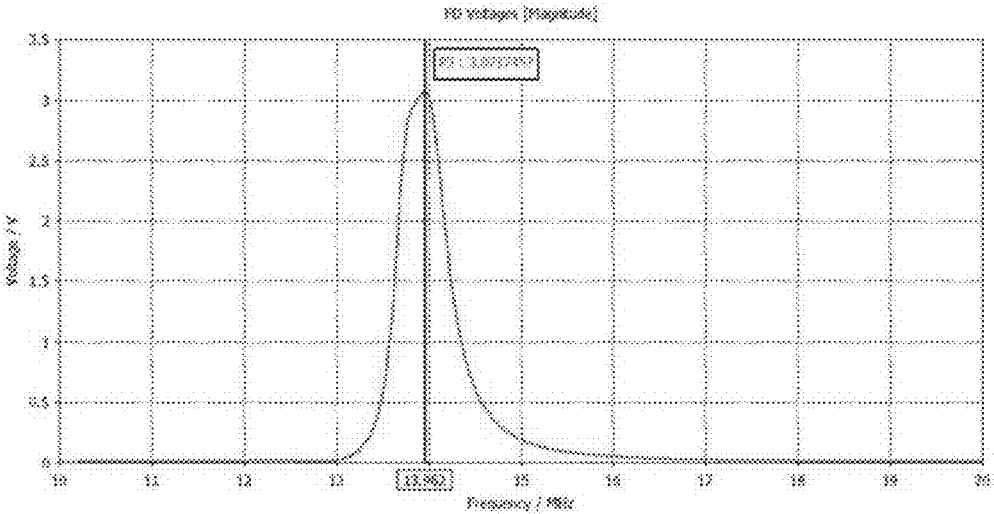

FIG. 4

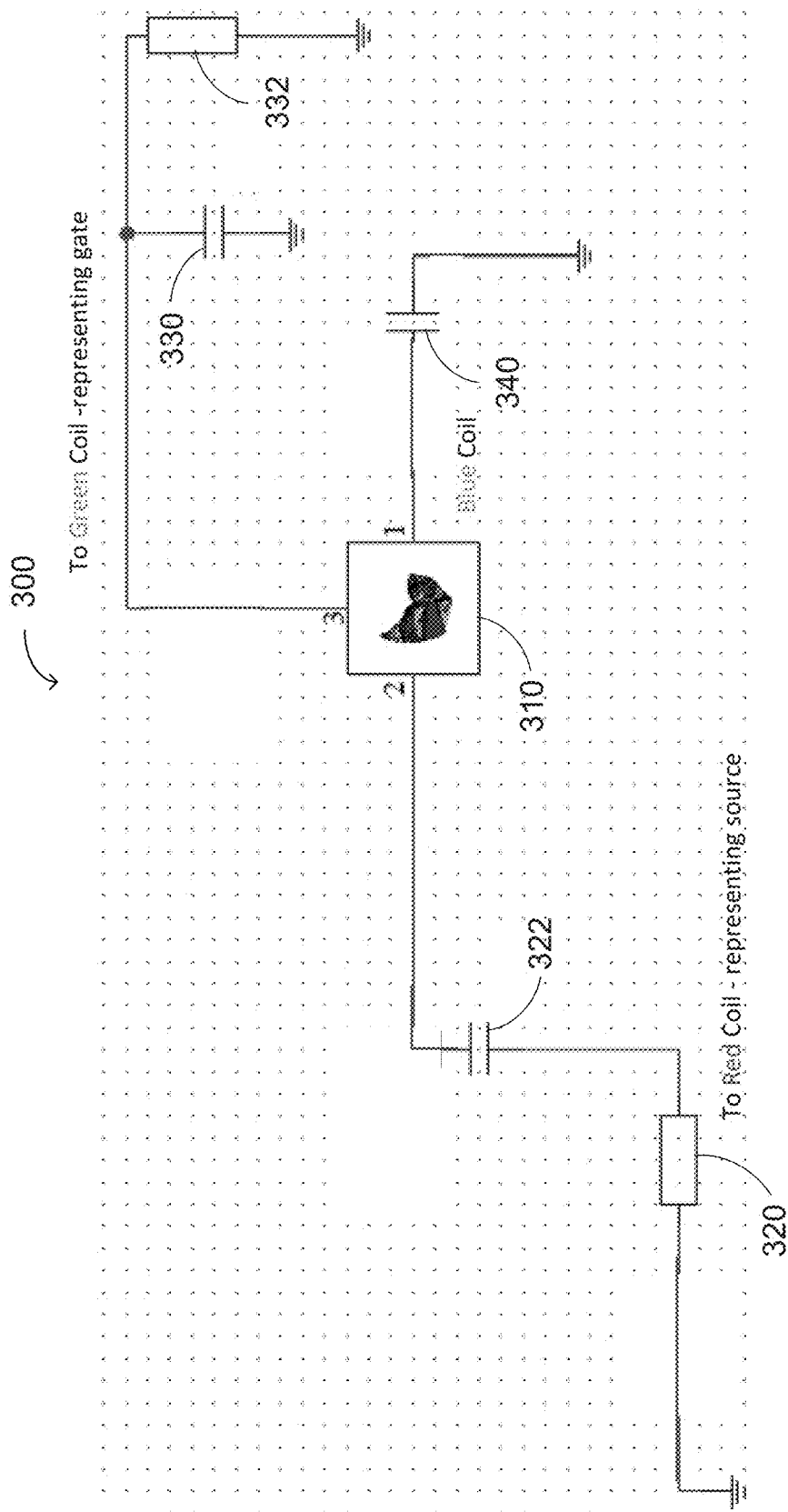

FIG. 5

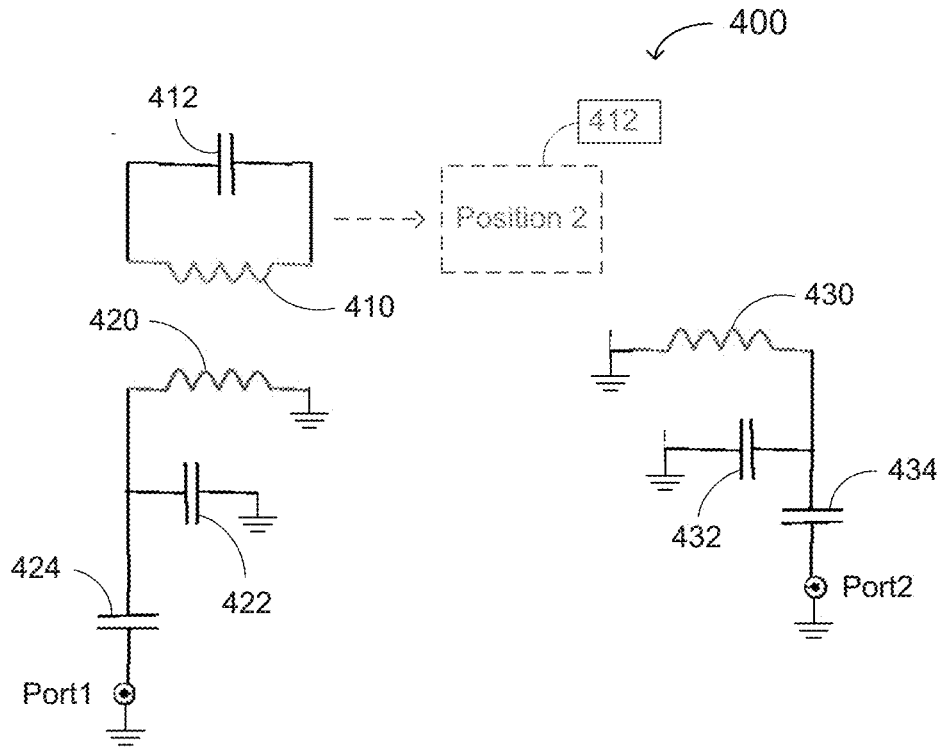
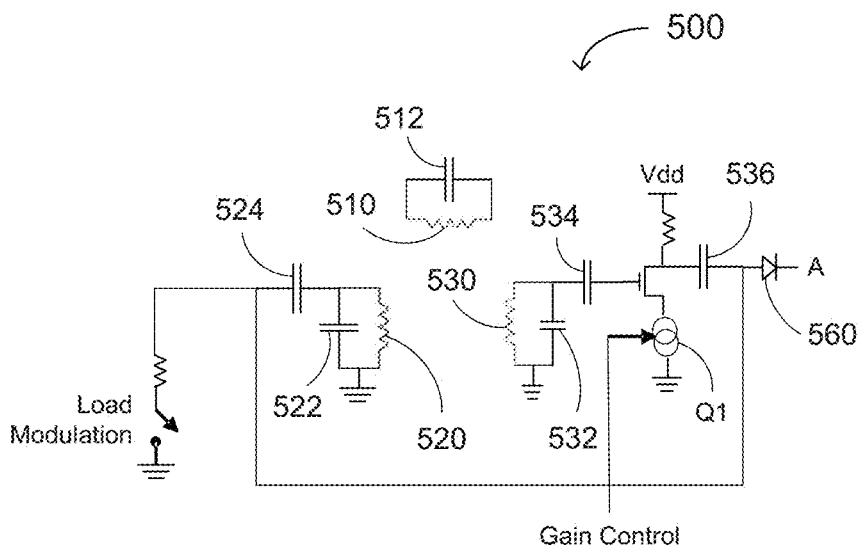

FIG. 8



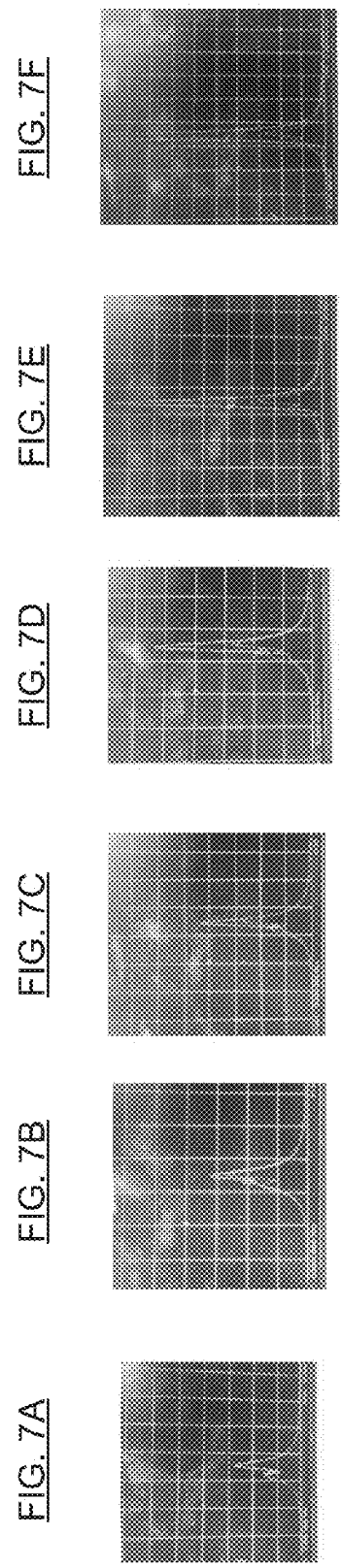
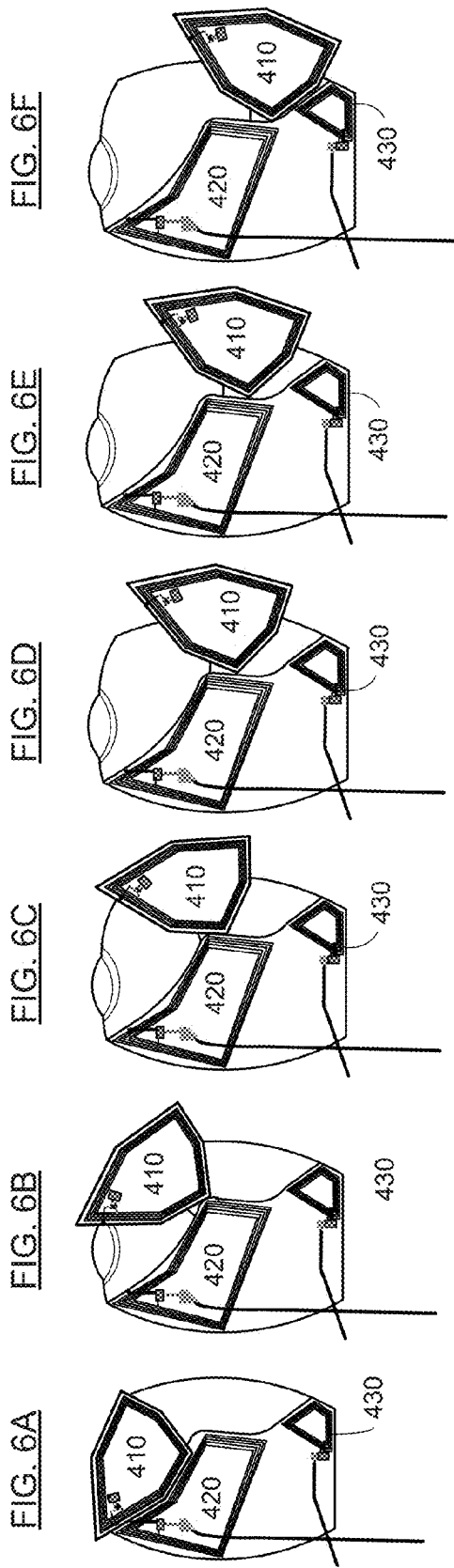

FIG. 9

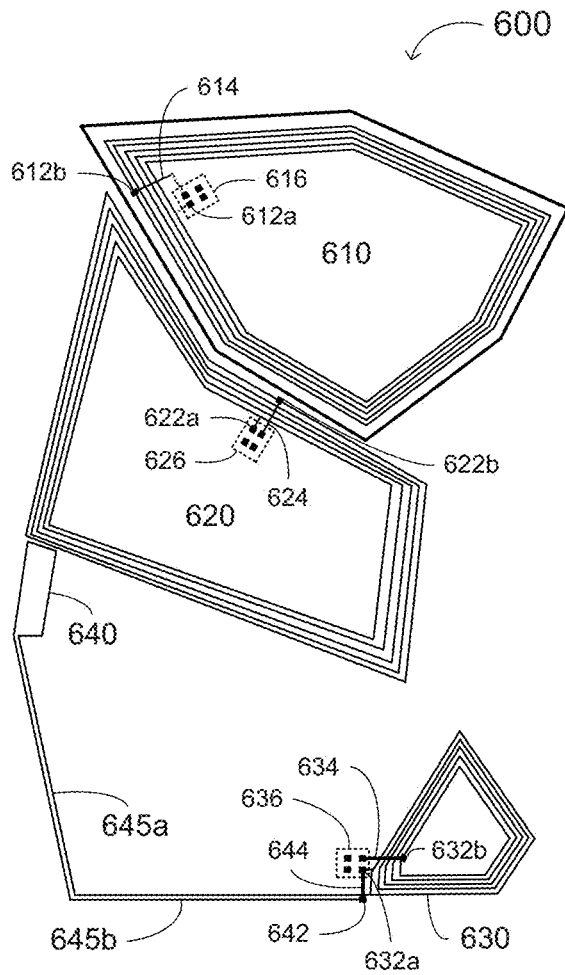

FIG. 10A

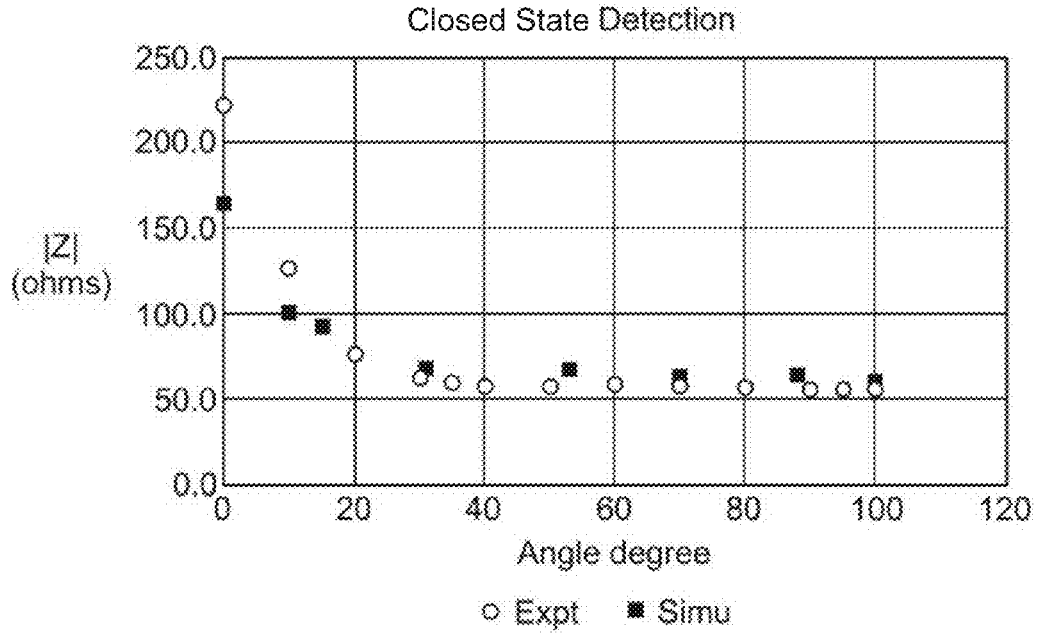

FIG. 10B

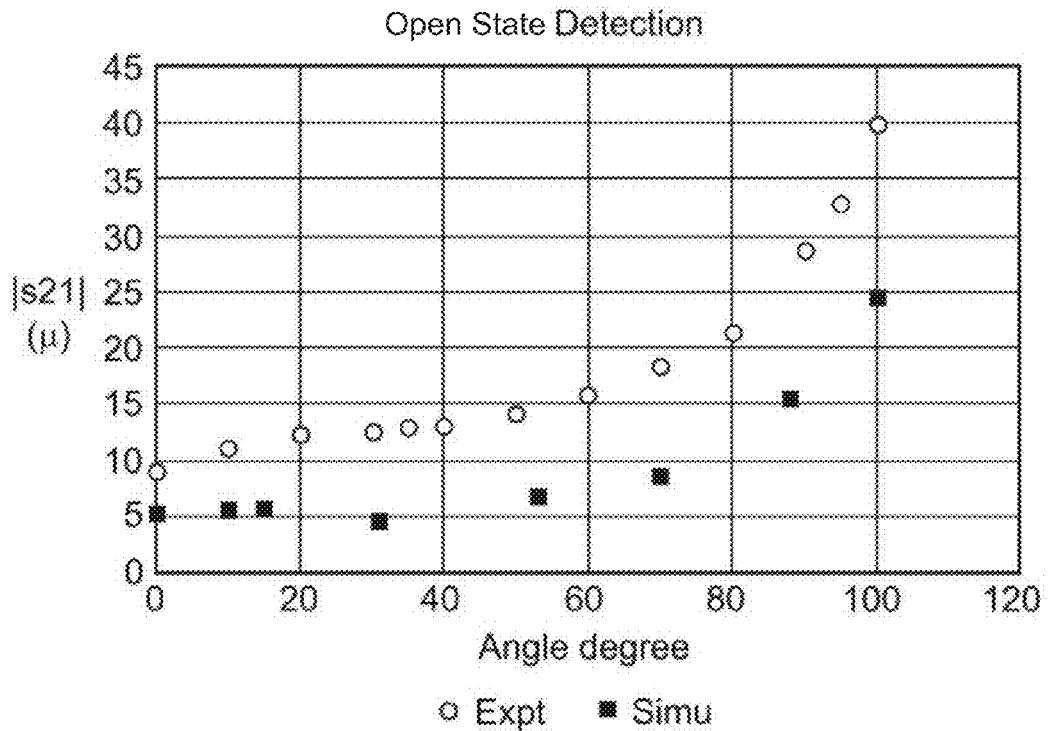

FIG. 11

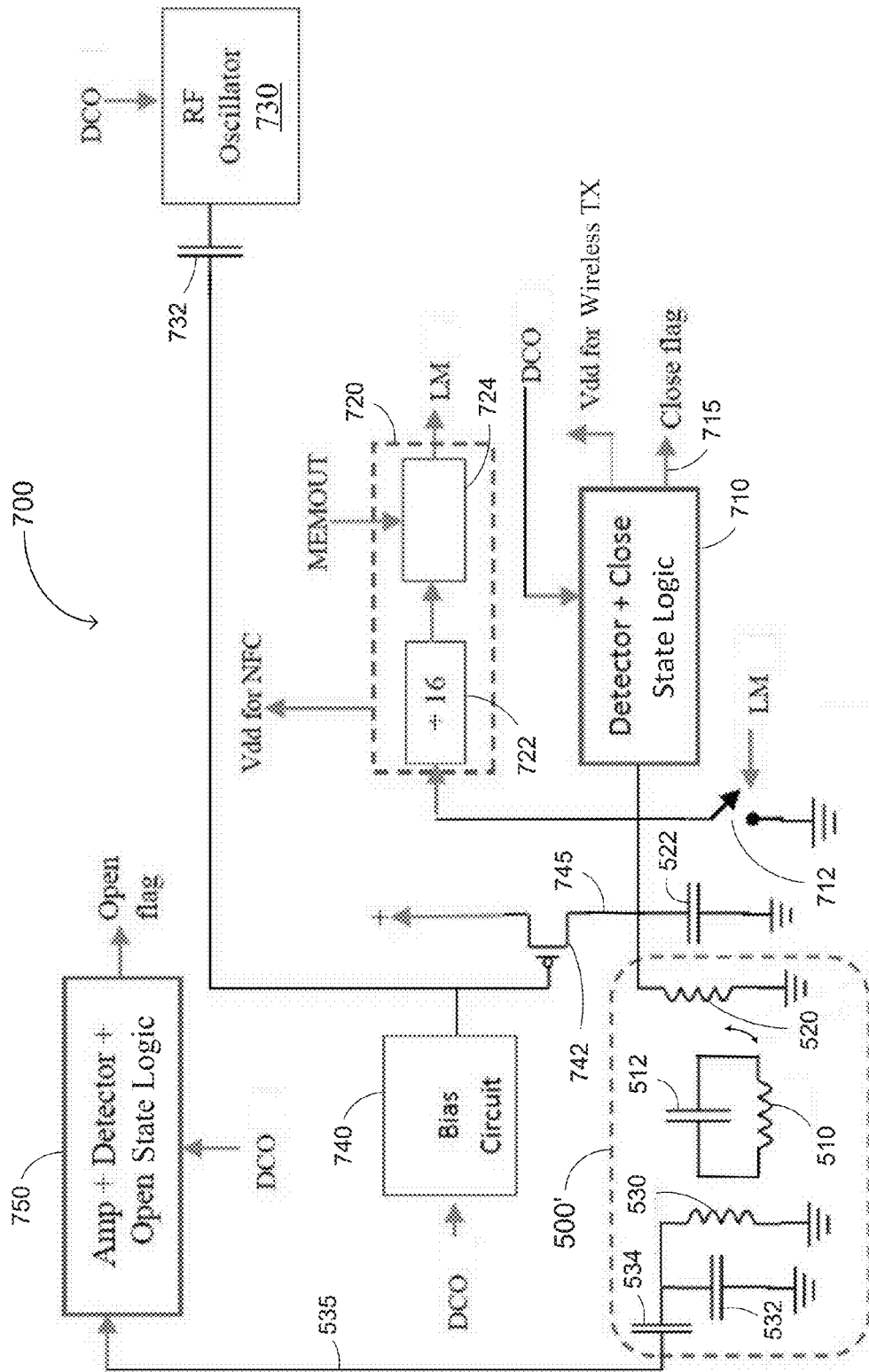

FIG. 12A

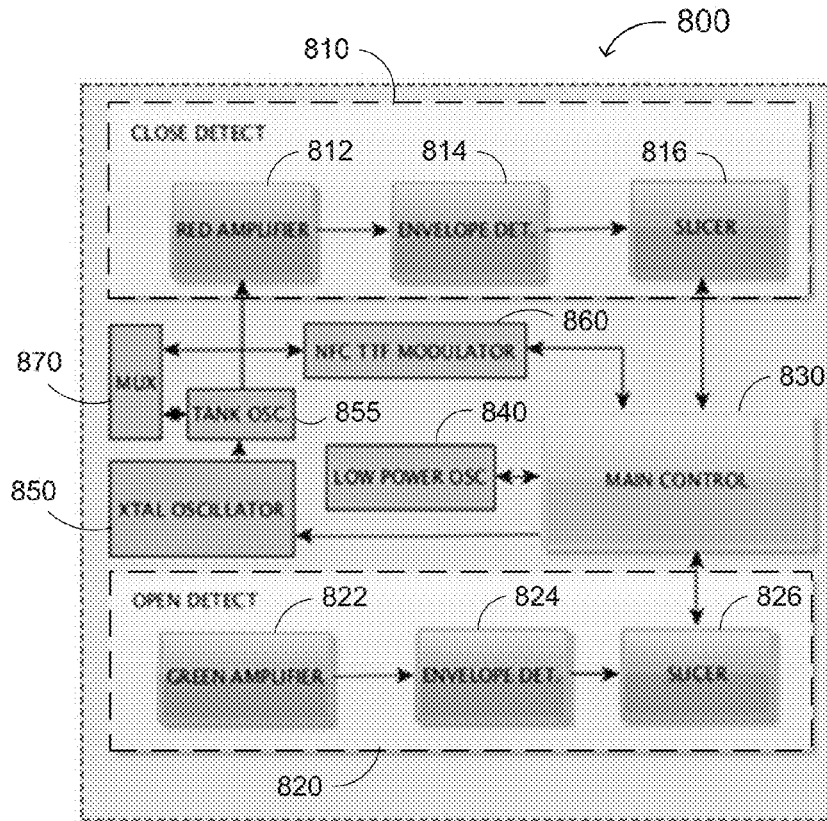

FIG. 12B

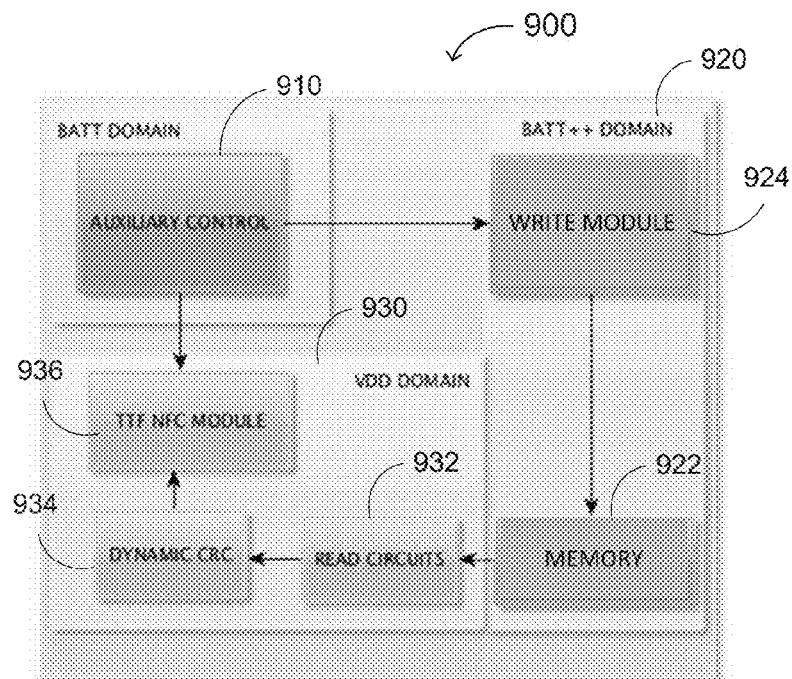

FIG. 13A

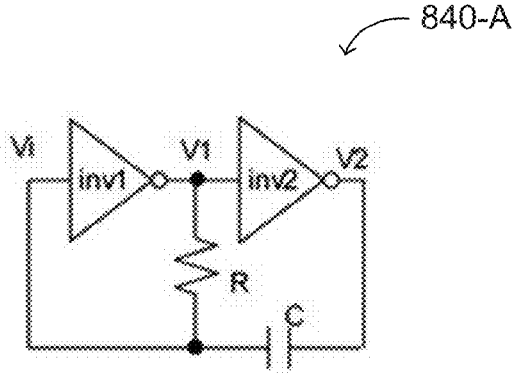

FIG. 13B

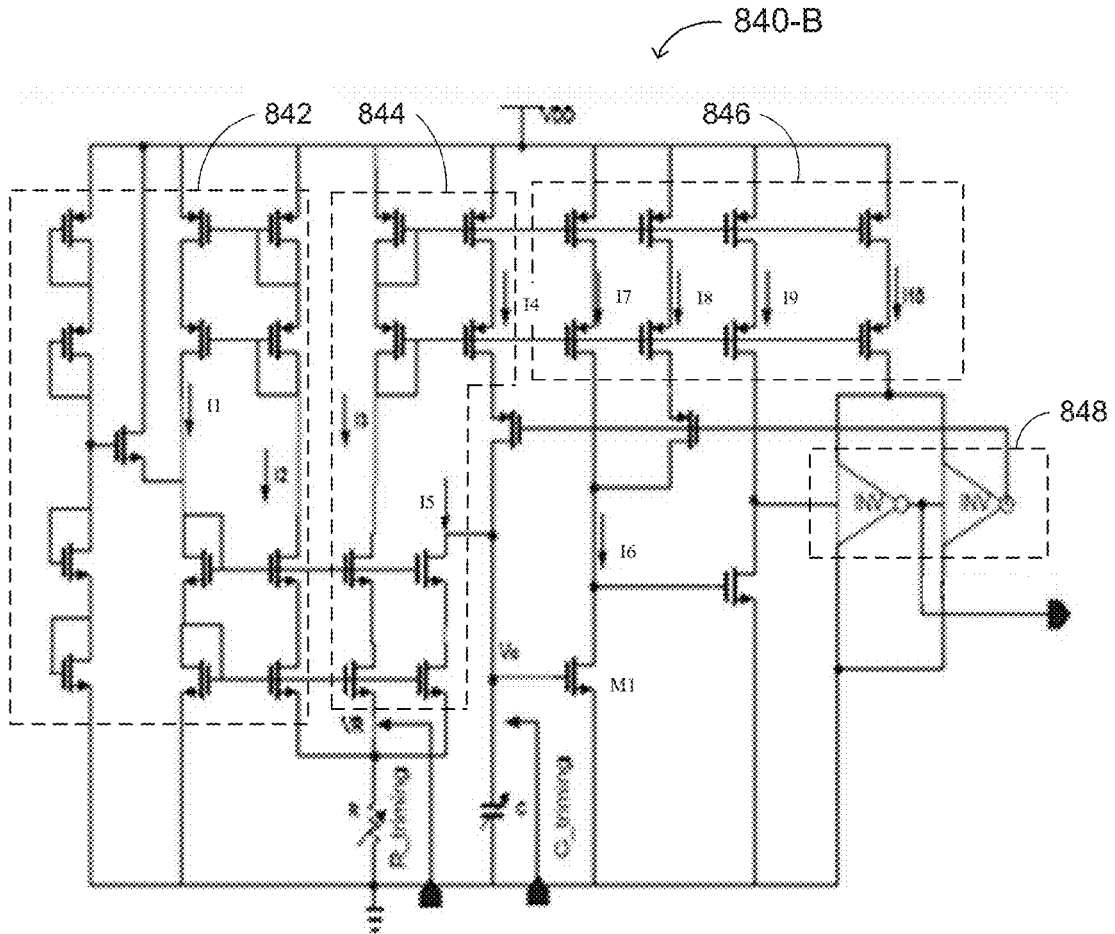

FIG. 13C

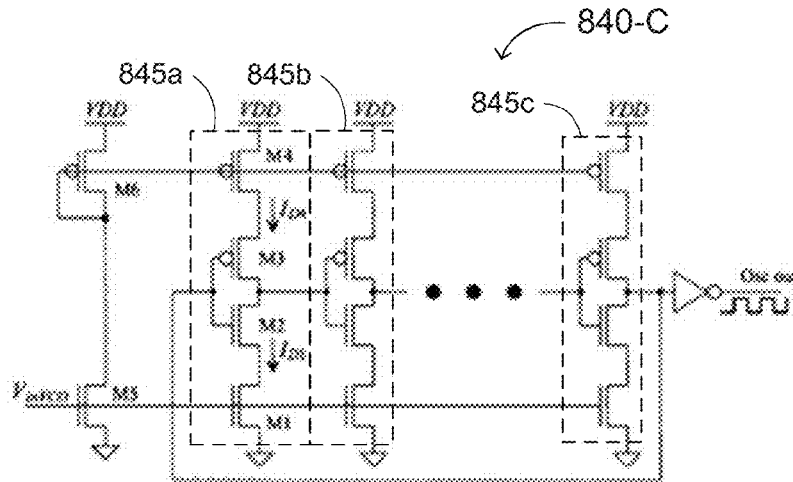

FIG. 14A

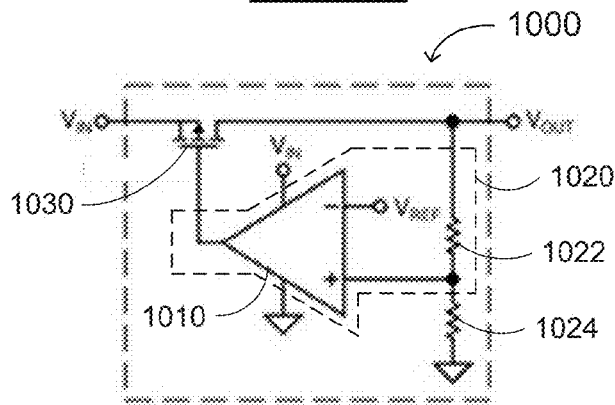

FIG. 14B

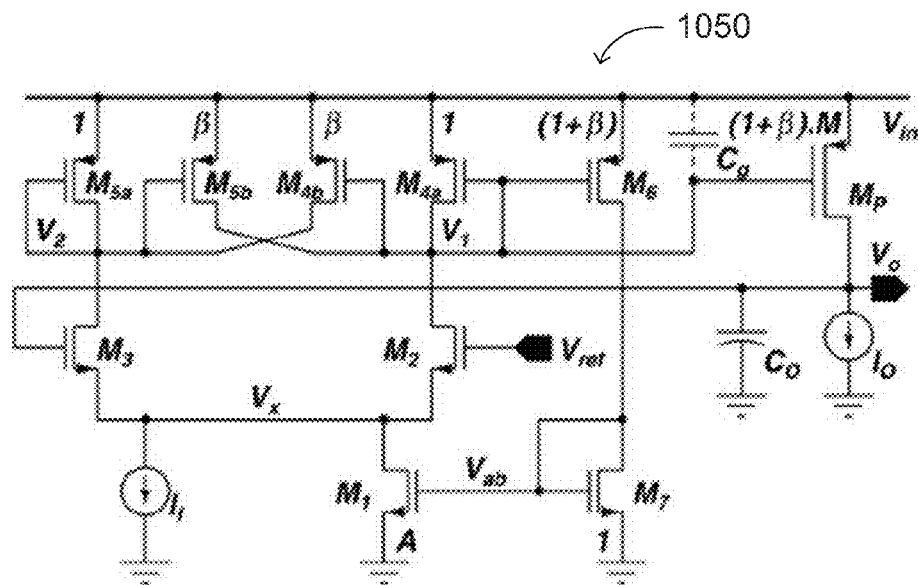

FIG. 15

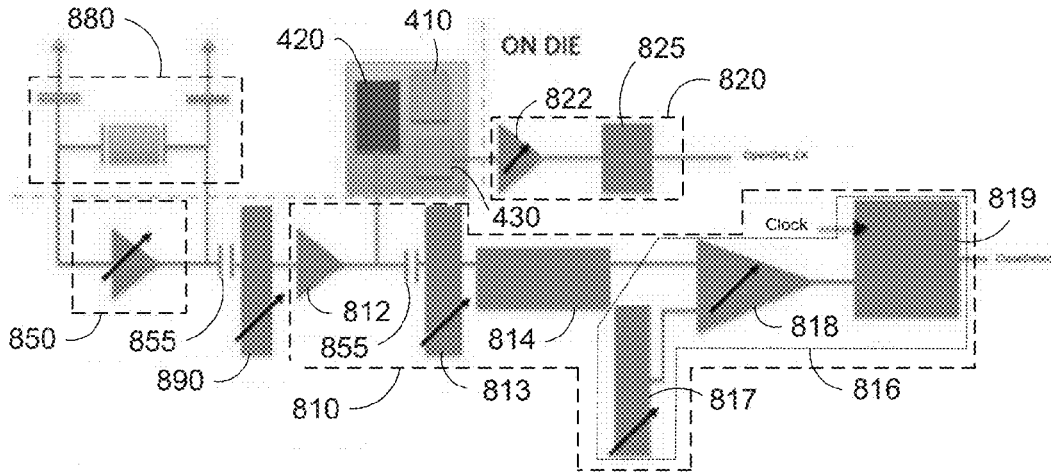

FIG. 16

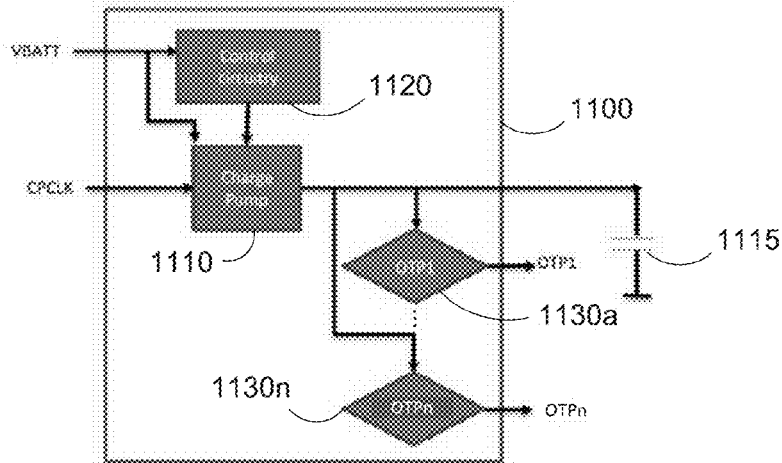

FIG. 17

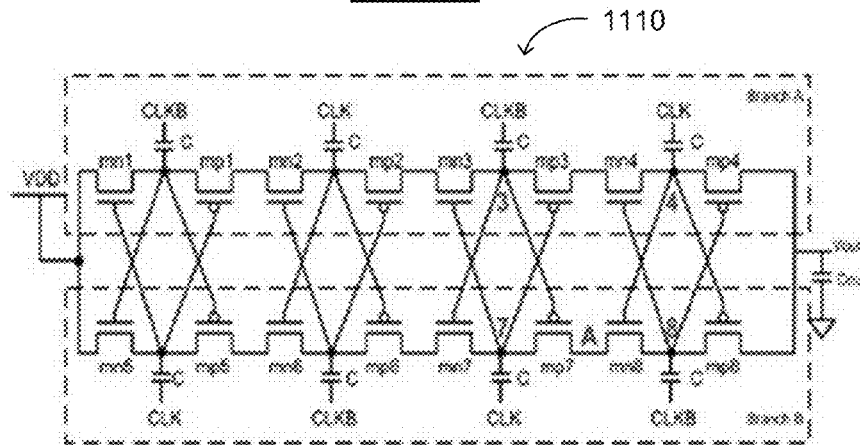

FIG. 18

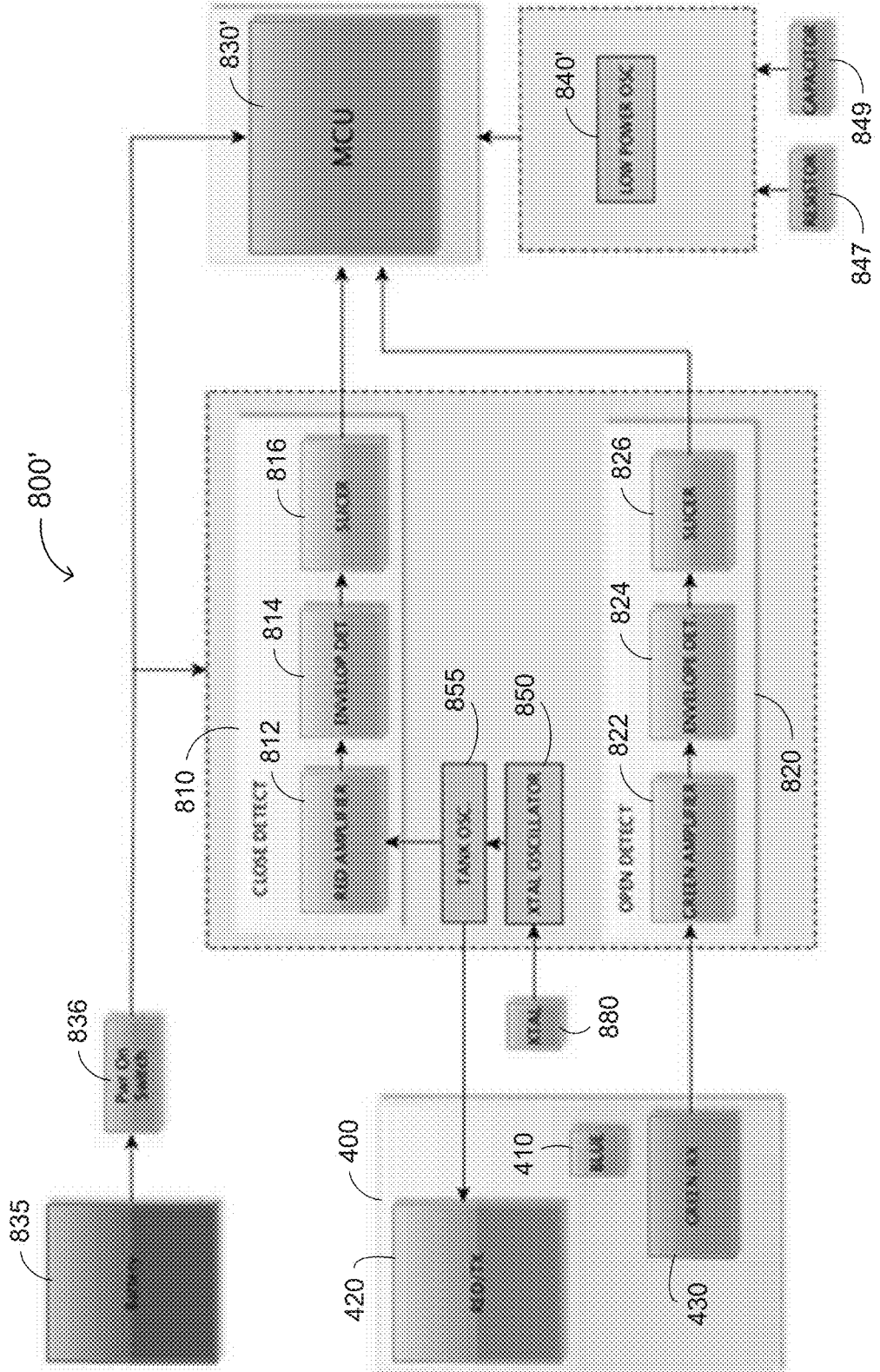
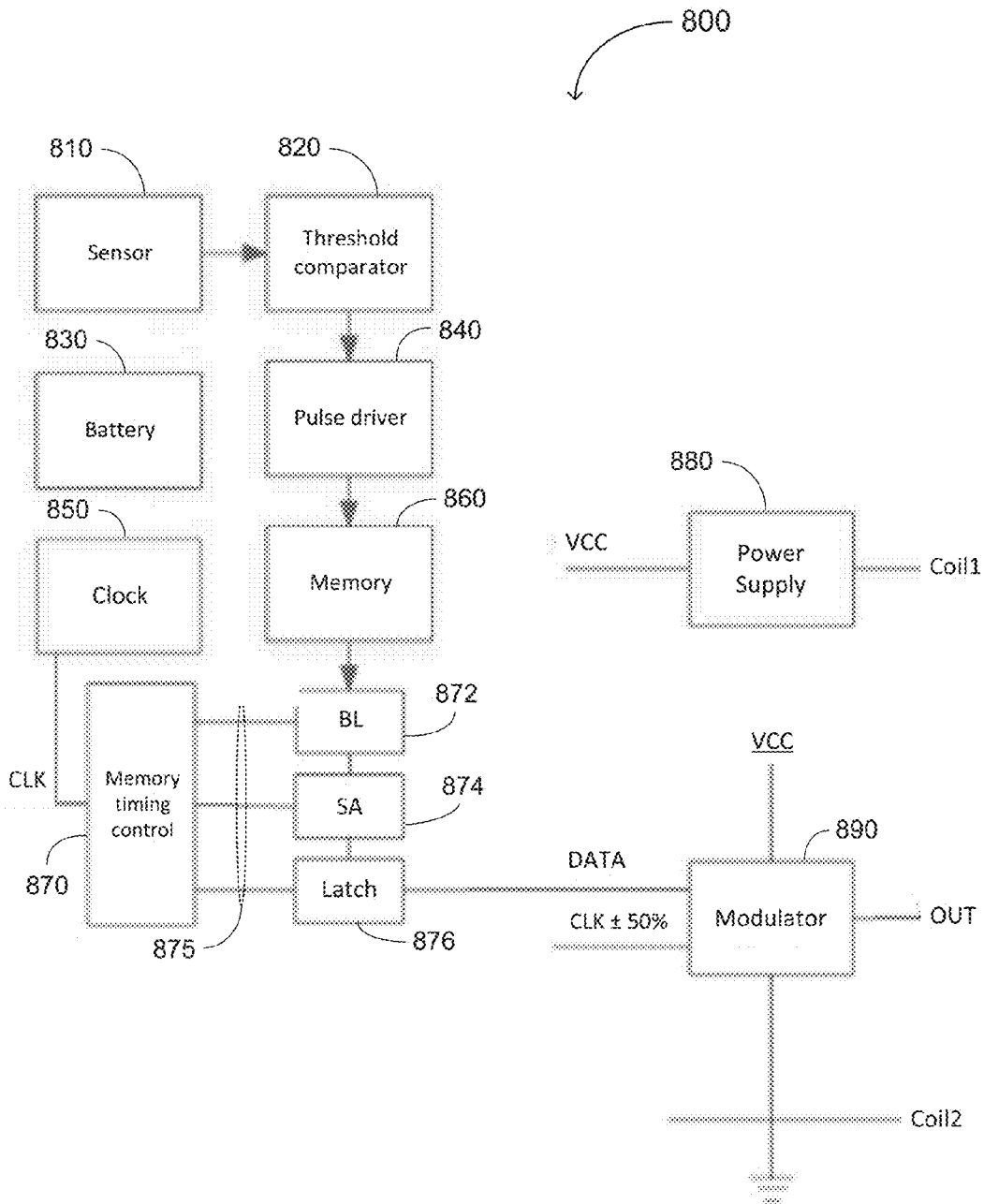

FIG. 19



**WIRELESS MECHANISM FOR DETECTING
AN OPEN OR CLOSED CONTAINER, AND
METHODS OF MAKING AND USING THE
SAME**

RELATED APPLICATIONS

[0001] This application claims the benefit of U.S. Provisional Patent Application No. 62/351,875, filed Jun. 17, 2016, incorporated herein by reference in its entirety.

FIELD OF THE INVENTION

[0002] The present invention generally relates to product security and authenticity. More specifically, embodiments of the present invention pertain to an electronic device and methods of making and using the same, in which the electronic device includes a plurality of coils for detecting an open or compromised container or product packaging. The present invention may also relate to a device and method for repeatedly detecting one of multiple states or modes of an article such as a container, housing or packaging for a product. For example, the device and method can determine the state of an article having a part (such as a lid or a cap) that is repeatedly movable between first and second states (e.g., corresponding to the article being open or closed).

DISCUSSION OF THE BACKGROUND

[0003] Certain product security and authentication technology relies on a wire that is torn or twisted off when the product packaging is opened. Ensuring a reliable, complete and irreversible tear can be challenging in various situations. Moreover, such technology can sense an opening event only once.

[0004] It can be useful to detect different positions of a part of an article that can move repeatedly between the different states. For example, certain medicine dispensers, such as blister packs and other multi-compartment pill or tablet dispensers, pumps, inhalation devices, etc., can be opened and closed (or raised and lowered) to obtain or deliver a dose of medication. Detection of the different positions (which can correspond to different states or modes) of such medicine dispensers is useful for monitoring a patient's compliance and/or adherence with a medicinal therapy or regimen.

[0005] This "Discussion of the Background" section is provided for background information only. The statements in this "Discussion of the Background" are not an admission that the subject matter disclosed in this "Discussion of the Background" section constitutes prior art to the present disclosure, and no part of this "Discussion of the Background" section may be used as an admission that any part of this application, including this "Discussion of the Background" section, constitutes prior art to the present disclosure.

SUMMARY OF THE INVENTION

[0006] The present invention relates to electronic devices and methods of manufacturing and using the same. The present invention relies on multiple antennas that are brought in proximity to induce positive feedback, resulting in oscillation or a change in state of a bistable device. The oscillation or change in state can be used to determine the state of the device.

[0007] In one aspect, the present invention relates to an electronic device, comprising a first substrate with first and second coils thereon, and a second substrate with a third coil thereon. The first coil has an integrated circuit electrically connected thereto, and the first substrate is a first part of an article, container or product packaging or is configured to be attached or secured to the first part of the article, container or product packaging. The second substrate is a second part of the article, container or product packaging, or is configured to be attached or secured to the second part of the article, container or product packaging. One of the first and second parts of the article, container or product packaging is removable or movable with respect to the other one of the first and second parts of the article, container or product packaging. The first and second coils have a first coupling when the article, container or product packaging is closed or sealed, and a second, different coupling when the article, container or product packaging is open or unsealed. In some embodiments, the first substrate may comprise one or more parts, and the first and second coils may be on the same part or different parts. In either case, the first and second coils are in fixed positions relative to each other.

[0008] In many embodiments of the electronic device, the first, second and third coils form a continuity sensor. The continuity sensor senses or determines a continuity state of the container or product packaging. In some cases, the first coupling corresponds to a closed or sealed continuity state, and the second coupling corresponds to an open or unsealed continuity state. Alternatively, the first coupling corresponds to the open or unsealed continuity state, and the second coupling corresponds to the closed or sealed continuity state. In further embodiments, the first and second coils can have a third coupling when the article, container or product packaging is partially open or not fully closed or sealed. In general (but not necessarily always), the third coupling is between the first coupling and the second coupling.

[0009] In some embodiments, one of the first and second parts of the article, container or product packaging may be removable or movable with respect to the other one of the first and second parts of the article. In a further embodiment, the removable or movable part is repeatedly movable between the open and closed continuity states. For example, a repeatedly movable part of the article, container or product packaging may be or comprise a cap or lid connected to the article or container by a hinge, a pivot or spindle, one or more tongue-in-groove fittings, etc.

[0010] In some embodiments of the electronic device, the continuity sensor further comprises a transistor electrically coupled directly or indirectly with at least one of the first and second coils. In some cases, the first, second and third coils form an open loop when the continuity sensor has the closed or sealed continuity state, and the third coil closes the loop when the continuity sensor has the open or unsealed continuity state. Alternatively, the first, second and third coils form a closed loop when the continuity sensor has the closed or sealed continuity state, and the third coil opens the loop when the continuity sensor has the open or unsealed continuity state. In further embodiments, the closed loop propagates an oscillating signal, and the open loop does not propagate the oscillating signal (e.g., from the first stationary coil to the second stationary coil).

[0011] In various embodiments, the second coil may have at least a first capacitor electrically connected thereto, and the third coil may have a second capacitor electrically

connected thereto. In other or further embodiments, the electronic device further comprises a diode or other element or circuit such as an envelope detector configured to detect the oscillating signal (or a maximum value thereof). The electronic device (e.g., the integrated circuit) may further comprise one or more devices configured to provide a bias current at a source/drain terminal of the transistor coupled to the first and/or second stationary coils. In some cases, the bias current may be controlled by a gain control signal comprising a sequence of pulses having a predetermined duty cycle.

[0012] In some embodiments, the continuity sensor may have a relatively high coupling state when the container or product packaging is closed or sealed, and a relatively low coupling state when the container or product packaging is open or unsealed. Alternatively, the continuity sensor may have a relatively low coupling state when the container or product packaging is closed or sealed, and a relatively high coupling state when the container or product packaging is open or unsealed.

[0013] In various embodiments, the electronic device may further comprise a battery configured to provide power to the integrated circuit. In other or further embodiments, the integrated circuit may comprise a rectifier configured to extract power from a wireless signal received by the first coil. The integrated circuit may also comprise a closed state detector and an open state detector. Each of the closed state and open state detectors may comprise an amplifier configured to amplify an output from a corresponding stationary coil, an envelope detector configured to determine a maximum value of an output from the corresponding amplifier, and a latch coupled directly or indirectly to an output of the envelope detector and configured to store the maximum value of the output from the corresponding amplifier.

[0014] In many embodiments, the integrated circuit comprises a printed integrated circuit. Printing is generally a high-throughput, additive technology that minimizes wasteful application of materials that must be subsequently removed, and avoids the use of expensive, low-throughput equipment such as photolithography equipment.

[0015] In another aspect, the present invention relates to an article, package or container, comprising first and second parts with an interface therebetween, where one of the parts is separable or movable with respect to the other. The first substrate of the present electronic device is, or is on, one of the parts of the article, package or container, and the second substrate is, or is on, another part (e.g., the other one of the first and second parts) of the article, package or container.

[0016] In some embodiments, the article, package or container is considered open when the first and second coils have the second coupling, and the package or container is considered closed or sealed when the first and second coils have the first coupling. For example, the third coil is closer to the first coil than to the second coil when the container or package is closed or sealed, and when the container or product packaging is open or unsealed, the third coil is (i) absent or (ii) closer to the second coil than when the container or package is closed or sealed. Alternatively, the article, package or container may be considered closed or sealed when the first and second coils have the second coupling, and the package or container may be considered open when the first and second coils have the first coupling.

[0017] In yet another aspect, the present invention relates to a method of detecting a continuity state of an article,

package or container, comprising placing first and second coils on a first part of the article, package or container, placing a third coil on a second part of the article, package or container, and sensing the continuity state of the article, package or container using the first, second and third coils. One of the first and second parts of the article, container or package is removable or movable with respect to the other one of the first and second parts of the container or product packaging. The first coil has an integrated circuit electrically connected thereto. The first and second coils have a first coupling when the article, package or container is closed or sealed, and a second, different coupling when the article, package or container is open or unsealed.

[0018] In various embodiments of the method, the article, package or container is considered open or unsealed when the first and second coils have the second coupling, and the article, package or container is considered closed or sealed when the first and second coils have the first coupling. Alternatively or additionally, the third coil may be closer to the first coil than to the second coil when the article, container or package is closed or sealed, and the third coil is (i) absent or (ii) closer to the second coil than when the article, container or package when the article, container or product packaging is open or unsealed.

[0019] As for the continuity sensor and article, package or container, the first, second and third coils may form a continuity sensor in the present method. The continuity sensor senses or determines the continuity state of the article, container or package. In some examples, the first coupling corresponds to a closed or sealed continuity state, and the second coupling corresponds to an open or unsealed continuity state. In other or further examples, the first, second and third coils may form a loop (which may be a feedback loop) when the continuity sensor has the closed or sealed continuity state, and the third coil breaks the loop when the continuity sensor has the open or unsealed continuity state. In some embodiments of the method, the loop propagates an oscillating signal when the continuity sensor has the closed or sealed continuity state, and does not propagate the oscillating signal when the continuity sensor has the open or unsealed continuity state. Alternatively, the opposite arrangements are also possible (i.e., the first coupling corresponds to an open or unsealed continuity state, and the second coupling corresponds to a closed or sealed continuity state; the first, second and third coils may form a loop when the continuity sensor has the open or unsealed continuity state, and the third coil breaks the loop when the continuity sensor has the closed or sealed continuity state; and/or the loop propagates the oscillating signal when the continuity sensor has the open or unsealed continuity state, and does not propagate the oscillating signal when the continuity sensor has the closed or sealed continuity state). In one example, the method further comprises detecting the oscillating signal with the open state detector when the continuity sensor has the open or unsealed continuity state.

[0020] Further embodiments of the method may further comprise applying a bias current at a source/drain terminal of a transistor coupled to the first stationary coil, controlling the bias current with a gain control signal comprising a sequence of pulses having a predetermined duty cycle, providing power to the integrated circuit using a battery and/or receiving a wireless signal at the first stationary coil. When the method comprises receiving the wireless signal at the first stationary coil, the method may further comprise

extracting power from the wireless signal with a rectifier (which may be part of the integrated circuit). As for the present continuity sensor and article, container or package, the integrated circuit may comprise a printed integrated circuit.

[0021] The present invention advantageously avoids any need to tear or break a wire when a container or product packaging is opened to determine its continuity state (e.g., whether it is “opened” or “closed”), and thus avoid issues that sometimes arise with product security and authentication technology that relies on tearing or breaking a wire. In some embodiments, the present invention is capable of sensing multiple continuity states as well as sensing a continuity state times (e.g., 10 or more times, 20 or more times, 30 or more times, 100 or more times, etc.) using two active (e.g., battery-powered) coils to generate electromagnetic fields, and a passive coil passing through the two fields to provide a voltage difference. These and other advantages of the present invention will become readily apparent from the detailed description of various embodiments below.

BRIEF DESCRIPTION OF THE DRAWINGS

[0022] FIG. 1 is a schematic for an exemplary 3-coil continuity sensor according to embodiments of the present invention.

[0023] FIGS. 2A-B are diagrams showing an exemplary design for a 3-coil continuity sensor according to one or more embodiments of the present invention.

[0024] FIGS. 3A-B are plots showing voltage on a second stationary coil of the exemplary design of FIGS. 2A-B as a function of the location of a moving coil.

[0025] FIG. 4 is a schematic for an exemplary equivalent circuit for the 3-coil continuity sensor of FIGS. 2A-B.

[0026] FIG. 5 is a schematic for another exemplary 3-coil continuity sensor according to one or more embodiments of the present invention.

[0027] FIGS. 6A-F are views of an exemplary prototype 3-coil continuity sensor according to one or more embodiments of the present invention.

[0028] FIGS. 7A-F are plots showing voltage on one coil of the exemplary prototype 3-coil continuity sensor of FIGS. 6A-F as a function of the location of another coil of the exemplary prototype 3-coil continuity sensor of FIGS. 6A-F.

[0029] FIG. 8 is a schematic for yet another exemplary 3-coil continuity sensor according to one or more embodiments of the present invention.

[0030] FIG. 9 shows an exemplary four-coil continuity sensing system according to one or more embodiments of the present invention, in which an auxiliary coil is added to the present three-coil system.

[0031] FIGS. 10A-B show results for the exemplary four-coil continuity sensing system of FIG. 9, in accordance with one or more embodiments of the present invention.

[0032] FIG. 11 shows an exemplary integrated circuit for use with an exemplary three-coil continuity sensor according to one or more embodiments of the present invention.

[0033] FIGS. 12A-B show exemplary alternative integrated circuitry to be connected to the first and second stationary coils of the present continuity sensor according to one or more embodiments of the present invention.

[0034] FIGS. 13A-C show circuit diagrams of exemplary oscillators for use with and/or in the exemplary integrated circuitry connected to the present continuity sensor according to one or more embodiments of the present invention.

[0035] FIGS. 14A-B show circuit diagrams of exemplary voltage regulators suitable for use with the present continuity sensors, in accordance with one or more embodiments of the present invention.

[0036] FIG. 15 shows a block diagram of exemplary closed and open state detectors for use with the present continuity sensors, in accordance with one or more embodiments of the present invention.

[0037] FIG. 16 shows control circuits for programming and/or writing to a nonvolatile memory in accordance with one or more embodiments of the present invention.

[0038] FIG. 17 shows an exemplary charge pump suitable for programming the nonvolatile memory of FIG. 16 in accordance with one or more embodiments of the present invention.

[0039] FIG. 18 shows an exemplary system including the present continuity sensor in accordance with one or more embodiments of the present invention.

[0040] FIG. 19 shows a diagram of another exemplary integrated circuit suitable for use with the present continuity sensors, in accordance with one or more embodiments of the present invention.

DETAILED DESCRIPTION

[0041] Reference will now be made in detail to various embodiments of the invention, examples of which are illustrated in the accompanying drawings. While the invention will be described in conjunction with the following embodiments, it will be understood that the descriptions are not intended to limit the invention to these embodiments. On the contrary, the invention is intended to cover alternatives, modifications and equivalents that may be included within the spirit and scope of the invention. Furthermore, in the following detailed description, numerous specific details are set forth in order to provide a thorough understanding of the present invention. However, it will be readily apparent to one skilled in the art that the present invention may be practiced without these specific details. In other instances, well-known methods, procedures and components have not been described in detail so as not to unnecessarily obscure aspects of the present invention. Furthermore, it should be understood that the possible permutations and combinations described herein are not meant to limit the invention. Specifically, variations that are not inconsistent may be mixed and matched as desired.

[0042] The technical proposal(s) of embodiments of the present invention will be fully and clearly described in conjunction with the drawings in the following embodiments. It will be understood that the descriptions are not intended to limit the invention to these embodiments. Based on the described embodiments of the present invention, other embodiments can be obtained by one skilled in the art without creative contribution and are in the scope of legal protection given to the present invention.

[0043] Furthermore, all characteristics, measures or processes disclosed in this document, except characteristics and/or processes that are mutually exclusive, can be combined in any manner and in any combination possible. Any characteristic disclosed in the present specification, claims, Abstract and Figures can be replaced by other equivalent characteristics or characteristics with similar objectives, purposes and/or functions, unless specified otherwise.

[0044] In the various drawings, use of like reference numerals indicates like features, but the use of dissimilar reference numerals does not necessarily indicate dissimilar features.

[0045] For the sake of convenience and simplicity, the terms “part,” “portion,” and “region” are, in general, interchangeable and may be used interchangeably herein, but are generally given their art-recognized meanings. Wherever one such term is used, it also encompasses the other terms. In addition, the terms “antenna” and “coil”, are used interchangeably, and where one term is used, it may also encompass the other term, but these terms are also generally given their art-recognized meanings. Also, unless indicated otherwise from the context of its use herein, the terms “known,” “fixed,” “given,” “certain” and “predetermined” may be used interchangeably and generally refer to a value, quantity, parameter, constraint, condition, state, process, procedure, method, practice, or combination thereof that is, in theory, variable, but is typically set in advance and not varied thereafter when in use.

[0046] The present invention advantageously enables electrical devices to detect or determine the continuity state of a container or package (which may be a multi-use container or package) without any need to tear or break a wire. However, in some embodiments, the present invention can be used in conjunction with a product authenticity sensor (e.g., based on OpenSense™ technology commercially available from Thin Film Electronics ASA, Oslo, Norway) that includes a wire crossing an interface of the product packaging. A further option is the use of such a wire on a tab, the pulling/tearing of which breaks the wire and disconnects a “battery off” switch or battery disable circuit to save battery power until the product is actually used. Furthermore, the present invention allows use of conventional, relatively simple circuit elements, relatively simple electrical and/or electromagnetic phenomena, and conventional processing, thereby minimizing the cost of manufacturing and/or the development time for certain tags (e.g., wireless devices and/or “smart” labels) including the present electrical devices.

[0047] The present invention concerns an electronic device including a continuity sensor that wirelessly senses the continuity state of a container or product packaging. The device relies on two antennas or coils on a first part of the container or product packaging and a third coil on a second, separable first part of the container or product packaging. The third coil couples the two antennas or coils on the first part of the container or product packaging (e.g., when the container or product packaging is in one of a plurality of different states). In a typical embodiment, the two antennas or coils on the first part of the container or product packaging have relatively low coupling in the absence of the third antenna/coil or when the container or product packaging is in a different state. Thus, the two antennas or coils on the first part of the container or product packaging are brought together (e.g., by inductive coupling) to induce positive feedback resulting in an oscillation or change in state of the electronic device, which in one or more embodiments is a bistable device (e.g., a device having two stable states, such as the “open” and “closed” continuity states). The oscillation or change in state can be detected to determine the change of state in the electronic device (e.g., an RF or NFC tag), and hence, the change in the state of the article (e.g., from closed

to open). The positive feedback can be generated by either electric or magnetic coupling.

[0048] One application of the present invention to product security and/or authentication involves a radio frequency (RF), near field communication (NFC) or other tag (e.g., a device that communicates using a wireless protocol such as Bluetooth and/or a predetermined frequency in the HF, VHF, UHF or RF band) on product packaging, in which two coils are placed on one part or component of the packaging, and the other coil is placed on another, separable part or component of the packaging. When the part or component of the product packaging containing the third coil is removed or separated, coupling between the remaining coils increases or decreases significantly (depending on the position of the third coil relative to the first two coils), which can be detected and used as a signal.

[0049] Another application of the present invention is directed towards detection of the continuity state of a multiple-use product or article, involving the radio frequency (RF), near field communication (NFC) or other tag on the product or article, in which two coils are placed on one part or component of product or article, and the other coil is placed on another, separable or separately movable part or component of the product or article. When the part or component of the product or article containing the third coil is moved relative to the two coils, a signal from one or both of the remaining coils changes significantly.

[0050] The present invention relies on multiple antennas/coils (typically three) to sense a continuity state (e.g., “open” or “closed”) of a container or packaging containing a product (e.g., an authentic product). One of the antennas/coils moves, or changes its position relative to the other two antennas/coils, the positions of which generally remain fixed. The moving antenna/coil works in conjunction with the two fixed antennas. In a first continuity state **1** (e.g., “closed”), magnetic coupling between the fixed coils is small. However, in a second continuity state **2** (e.g., “open”), magnetic coupling between the fixed coils is increased due to the presence of the moving coil. Alternatively, this can work in the complementary way (i.e., in the first continuity state, magnetic coupling between the fixed coils is high due to the presence of the moving coil, and in the second continuity state, the magnetic coupling between the fixed coils is relatively small). This property may be used to construct continuity sensors that do not require physical connection (e.g., a wire) and that can be used and possibly re-used any number of times. Moreover, it may be possible to determine intermediate states between the first and second continuity states (e.g., to quantify the degree of container/package openness or security/continuity, to identify a “partially open” state, etc.).

[0051] The technique can be extended to the use of electric coupling instead of magnetic coupling.

[0052] FIG. 1 shows a continuity sensing system **100** that illustrates the basic principle behind the invention. The exemplary continuity sensing system **100** includes first and second stationary coils (e.g., red and green coils **102** and **104**) and a third coil (blue coil **106**) that changes position (e.g., that moves from one position proximate to the first coil **102**, but relatively distant from the second coil **104**, to another position closer to the second coil **104**, but in which the center of the third coil **106** is relatively distant from the first coil **102**). The proximity of the third coil **106** (e.g., the moving coil) increases coupling between the first and second

coils **102** and **104** (e.g., the stationary coils). In absence of the third coil **106**, coupling between the first and second coils **102** and **104** is low by design.

[0053] Continuity sensing generally refers to a capability and/or function that senses or determines whether an article, a container or product packaging is open (or, in the case of product authenticity and/or security, has been tampered with) on the one hand, or is closed (e.g., in the case of product authenticity and/or security, in its factory-sealed condition) on the other hand. Continuity sensing also includes in some cases determining whether the article, container or product packaging is partially open or has one or more of a plurality of parts or compartments that are open and one or more parts or compartments that are closed.

[0054] When determining the continuity state of the container or product packaging (e.g., when the electronic device is in an “open/closed” detection mode), none of the coils **102**, **104** or **106** needs to receive a signal from a reader (assuming the electronic device in a tag on the container or product packaging is powered by an internal power source, such as an integrated or external battery). However, the first coil **102**, and optionally the third coil **106** and/or the second coil **104**, can participate in communicating information to the reader. Thus, the coils **102**, **104** or **106** may have a dual role; that is, the same coils that enable open/closed state detection (e.g., that are in the continuity sensor) can also participate in NFC or other wireless communications. The open terminals on the first and second coils **102** and **104** are connected to other elements and/or components completing a circuit.

[0055] FIG. 2A shows a system **200** designed to demonstrate the feasibility of a continuity sensor based on one or more principles of the continuity sensing system **100** in FIG. 1. A third coil **210** on a first substrate **220** was placed in a first position in proximity to a first coil **230** on a second substrate **240**. A second coil **250** was also on the second substrate **240**. The first and second substrates **220** and **240** can be a label (e.g., a flexible plastic film that further includes an adhesive and that may further include graphics and/or one or more layers of paper and/or metallization), a backing sheet for electronics, etc. Alternatively, the first, second and third coils can be formed on and/or embedded in the product container/housing itself, and thus not on a separate substrate (e.g., the container may be the substrate for the first and second coils **230** and **250** and/or the third coil **210**). Furthermore, the coils **210**, **230** and **250** may be printed on the first and second substrates **220** and **240**.

[0056] In various embodiments, the first coil **230**, which can be involved in wireless signal reception/transmission, has an integrated circuit (IC; not shown, but which may be a printed IC on the same or a separate substrate, which may be a flexible substrate, such as a product label) coupled or electrically connected to it through the bonding pads **232** and one or more capacitors electrically connected to it and/or the IC through the bonding pads **232** and/or **234**. Furthermore, the second coil **250** and the third coil **210** (which are generally not involved in wireless signal reception/transmission) may have one or more capacitors electrically connected to them through the bonding pads **252** and/or **212**. The capacitor(s) connected to the second coil **250** may be part of a printed IC (PIC) that is generally (but not necessarily) separate from the printed IC coupled or electrically connected to the first coil **230**. The capacitor(s) and/or PIC connected to the second coil **250** may be on the

same or a separate substrate (which may be a flexible substrate, such as a product label) as the second coil **250**. Alternatively, the capacitor connected to the second coil **250** may be an external component(s). The capacitor(s) connected to the third coil **210** are separate (e.g., an external component) because the third coil **210** is physically removed from the part of the container or product packaging on which the first and second coils **230** and **250** are located (e.g., the “main body” of a product container) or is otherwise physically relocated relative to the first and second coils **230** and **250**. The capacitor(s) connected to the third coil **210** can be a standard part, implemented as a PIC or implemented as part of the third coil. In each case, the capacitor(s) coupled to the respective coil generally have a capacitance and/or other parameter values adapted to facilitate or enable resonance of the coil(s).

[0057] The third coil **210** was made to resonate at approximately 14 MHz, and an excitation was applied at the first coil **230**. The voltage at the second coil **250** was monitored. FIG. 3A is a graph showing the voltage on the second coil **250**, which was about 0.56 V (by simulation) at the resonant frequency.

[0058] FIG. 2B shows the system **200** in which the third coil **210** is in a second, different position with respect to the red and green coils **230** and **250** (which remain in the same positions with respect to each other). The second position of the third coil **210** corresponds to a torn or opened product package or container. In the second position of the third coil **210**, the first coil **230** is more strongly coupled to the second coil **250**. As shown in the graph of FIG. 3B, the voltage on the second coil **250** was about 3.07 V (by simulation) when the third coil **210** was in the position shown in FIG. 2B, between 5 and 6 times the voltage on the second coil **250** when the third coil **210** is in the low-coupling state (e.g., as shown in FIG. 2A). Thus, the states of the bistable continuity sensor **200** can be characterized as a “high-coupling state” and a “low-coupling state.”

[0059] In various embodiments of the invention, the high-coupling and low-coupling states of the system **200** correspond to different states (for example, different continuity states such as closed and open) of a container or product packaging with which the system **200** is associated (for example, by attachment to or incorporation in the product container or housing). In some embodiments, at least one component of the system **200** (e.g., part of the product container or packaging) is able to move repeatedly between different states as described above (e.g., back-and-forth), and consequently, can be associated with a product that has a feature that can be repeatedly movable between different states or positions so as to detect such changes of product state. Over time, a history of the product states can be compiled. This is particularly useful for determining compliance with a medical therapy or treatment regimen when the product is a medicine delivery article or system.

[0060] FIG. 4 shows an equivalent circuit **300** for the system shown in FIGS. 1 and 2A-B. The equivalent circuit **300** includes a three-port circuit element **310**, a first path to the first coil comprising a resistor **320** and a capacitor **322**, a second path to the second coil comprising a capacitor **330** and a resistor **332**, and a third path that includes or is to the third coil comprising a capacitor **340**. The resistor **320** may have a resistance that is higher than (e.g., by 2-5×) the resistance of the resistor **332**. The capacitor **322** may have a capacitance that is higher than (e.g., by 2-3×) the capaci-

tance of the capacitor **340**, and the capacitor **330** may have a capacitance that is higher than (e.g., by 3-4×) the capacitance of the capacitor **322**. The three-port circuit element **310** is not necessarily a physical circuit element, but rather, may be a representation of a circuit element that couples the different coils to each other inductively and/or capacitively.

[0061] Experimental verification of the feasibility of a 3-coil continuity sensor was further performed using a 3-coil system **400** as shown in FIG. 5. The position of the third coil **410** changes from a first position corresponding to a “closed” state to a second position corresponding to an “open” state. The fixed first and second coils **420** and **430**, respectively, are shown in association with matching capacitors **422**, **424**, **432** and **434** for impedance matching and are resonant nominally at the same frequency. The moving third coil **410** is made resonant with a single capacitor **412** nominally at the same frequency.

[0062] When the movable coil **410** is in a first position or location corresponding to a closed continuity state, the gain between port 1 and 2 ($|s_{21}|$) is small. When the movable coil **410** is in a second position or location corresponding to an open continuity state, $|s_{21}|$ is appreciable (e.g., significantly larger than in the first position or location), and there is a phase shift (e.g., of 180° or about 180°) close to the resonant peak. Therefore, it is possible to utilize this property to construct a continuity detector or sensor, or to measure an amount or degree of packaging/container continuity.

[0063] FIGS. 6A-F show various positions of the third coil **410** as it changes from a first position corresponding to a “closed” state in FIG. 6A to a second position corresponding to a fully “open” state in FIG. 6F. The third coil **410** is a movable coil, whereas the first coil **420** and the second coil **430** have fixed positions with respect to each other. The first, second and third coils **410**, **420** and **430** are shown as concentric rings or loops, but in practice, they comprise a spiral, with a gap in each ring or loop and an electrical connection between adjacent rings or loops.

[0064] An excitation was applied at the first coil **420** when the third coil **410** in each of the positions shown in FIGS. 6A-F, measurements of the voltage on the second coil **430** were taken (using a conventional voltmeter), and plots of the voltage on the second coil **430** when the third coil **410** was in each of the positions shown in FIGS. 6A-F are shown in the corresponding FIGS. 7A-F. Thus, FIGS. 6A-F and 7A-F show or represent the signal level of a tag having 3 coils arranged as described herein as a function of the position of a cover (e.g., a hinged cover, on which the third coil **410** is placed or secured). In one example, the third coil **410** may be printed on a label that is secured to the cover using an adhesive.

[0065] The signal on the second coil **430** in FIG. 7F (corresponding to the fully “open” state of the coils in FIG. 6F) is about 4 times greater than the signal on the second coil **430** in FIG. 7A (corresponding to the “closed” state of the coils in FIG. 6A). Furthermore, the signal on the second coil **430** in FIG. 7D (corresponding to the position of the third coil **410** in FIG. 6D) is about 2 times greater than the signal on the second coil **430** in FIG. 7A. An increase in signal strength of 2× relative to the “closed” state (optionally, for at least a predetermined minimum length of time) may indicate or correspond to an “open” or “partially open” state, depending on the configuration and/or parameters of the continuity sensor (e.g., the gain of the electronic device or continuity sensor when a continuity loop therein oscillates,

which must be less than the signal strength difference between “open” and “closed” states; see, e.g., the discussion of FIG. 8 below). The voltage on the second coil **430** corresponds directly to the strength of a wireless signal transmitted or broadcast by the first coil **420** and/or the extent to which the third coil **410** couples the first coil **420** to the second coil **430**.

[0066] The example of FIGS. 6A-E is a relatively simple example, to verify that the concept behind the present invention is feasible. For example, the locations and/or geometries of the coils are not particularly limited and may be further optimized and/or shaped for a particular application (e.g., to conform to the product, container or packaging to which it will be applied to or into which it will be incorporated) without undue experimentation. Although a comparison of the two plots in the photos of FIGS. 7A-F show an increase of about 4× in FIG. 7F for the high-coupling state, increases in signal strength for the high-coupling (or, in this example, “opened”) state of >5× relative to a low-coupling (or, in this example, “closed”) state have been experimentally demonstrated. The lower plot (shown by itself in FIG. 7A) shows weak coupling (corresponding to the “closed” state shown in FIG. 6A, in which the third coil **410** is relatively far away from the second coil **430**). The upper plots (especially in FIGS. 7D-F) show strong coupling, as the third coil **410** moves closer to the second coil **430**. Furthermore, electrical coupling (as a dual or alternative of magnetic coupling) may be applied to, and may be more suitable for, certain situations and/or embodiments.

[0067] Non-limiting examples of articles (e.g., containers or product packaging) that have one stationary part and another part that is repeatedly movable between a first state (e.g., an open state) and a second state (e.g., a closed state) include dispensers (for example, medicine dispensers such as inhalation devices, and bottles or jars with pump dispensers), bottles or jars with caps (which may be hinged or otherwise fastened or secured to the bottle or jar), containers with hinged or sliding lids, boxes with hinged flaps such as regular slotted containers, etc.

[0068] Furthermore, as shown by the relationship between the positioning of the coils in FIGS. 6A-F and the voltages induced on the coil **430** as shown in FIGS. 7A-F, accurate sensing and/or counting can be performed as a function of the position of the passive coil **410** (e.g., the percentage of the distance between a first position corresponding to a fully closed state and a fully open state, or in the case of the passive coil **410** traversing an arcuate path, the angle of the passive coil **410** relative to the fully closed state or fully open state). For example, the “closed” state may correspond to 0-30% of the distance between the first and second positions, a “partially open” state may correspond to >30% and <80% of the distance between the first and second positions, and an “open” state may correspond to 80% or more of the distance between the first and second positions. However, the thresholds between the different continuity states can vary in different examples. The “closed” state may correspond to from 0-5% to 0-60% of the distance between the first and second positions, the “open” state may correspond to from 50% or more to 95% or more of the distance between the first and second positions, and the “partially open” or “partially closed” state may be the range of distances between the “closed” and “open” states, as long as none of the distance ranges overlap. Alternatively, the thresholds between different continuity states can be defined

by the voltage induced on the second coil **430**. For example, the “closed” state may correspond to a voltage of 1-1.5 times the voltage on the second coil when the passive coil is in the first position, a “partially open” state may correspond to 1.5-3 times the voltage on the second coil when the passive coil is in the first position, and an “open” state may correspond to greater than 3 times the voltage on the second coil when the passive coil is in the first position. Often, one or more inflections are apparent in the curve or plot of the voltage on the second coil as a function of the position of the passive coil, and such inflections can provide useful thresholds for determining different continuity states. The numbers given in these examples are exemplary, and the invention is not limited to these examples in any way.

[0069] FIG. 8 shows another equivalent circuit for an exemplary continuity sensor in accordance with one or more embodiments of the present invention. The above-described properties of the three-coil system can be used to induce positive feedback resulting in oscillation. In one embodiment, the combination of three coils (e.g., the first, third and second coils) is placed in the feedback path of an amplifier to induce oscillations.

[0070] Gain control in the transistor **Q1** is achieved by changing a bias current at the gate of the transistor **Q1**, which is controlled by the amount of coupling of an excitation at the first coil **520** to the second coil **530**, and/or by applying a bias current to a source/drain terminal of the transistor **Q**. The bias current (e.g., source/drain current) is under open loop control, which is advantageous for embodiments in which the sensor and IC are powered by a battery, as open loop control (e.g., without use of feedback) conserves battery power when the high-coupling state is maintained for a relatively long period of time, and helps with NFC and possibly other wireless communications while the sensor is in the high-coupling state. By default, the gain of the transistor **Q1** is set to a low enough value that current drain is small. This is particularly advantageous in embodiments in which the tag/electronic device is powered by a battery, rather than by extraction of power from a received wireless (e.g., RF or NFC) signal (which is the case in some alternative embodiments). Also, in one or more embodiments, the Load Modulation switch is off.

[0071] In a weak coupling scenario, there may not be enough loop gain in the transistor **Q1** to overcome losses in the coils **510**, **530** and **550** and induce oscillations (e.g., in a loop comprising the first, third and second coils **510**, **530** and **550** and the transistor **Q1**). For example, when the third coil **510** is absent or far away (e.g., from the second coil **550**), losses in the coils **510**, **530** and **550** increase or are relatively high, which can bring the loop gain to below unity (e.g., <1). In this condition, oscillations may not occur. However, when the third coil **510** is in a position to introduce strong coupling, the loop gain can exceed unity, and the loop phase shift is 0° (e.g., since the first, third and second coils **510**, **530** and **550** introduce a 180° phase shift near resonance, as does the transistor **Q1**, resulting in a total phase shift of 0° in the loop). The oscillations, which occur when the continuity state of a container or product packaging on which the electronic device is attached or secured is a high-coupling state, generate a DC voltage at the output A of the diode **560**. The amplitude of the oscillations (e.g., the amount of coupling) determines the magnitude of the DC voltage at output A of the diode **560**.

[0072] The electrical device **500** may be used for wireless (e.g., NFC or RF) read operations. The antenna(s) **510**, **520** and **530** as described above are used to sense the presence of an NFC signal from a handheld device (such as an NFC-enabled smart phone) and communicate back to the handheld device. In presence of an NFC field, a finite voltage gets generated at the output A of the diode **560** even in the “closed” (e.g., weak coupling) state (i.e., where there is no oscillation). However, the diode **560** detects the oscillations when the voltage at output A has a duration that exceeds a predetermined threshold (e.g., a duration that is longer or significantly longer than that caused by NFC or other wireless interrogation). However, there may be other components and/or ways to detect the oscillation, so the invention is not limited to use of a diode to do so. The load modulation switch may be activated when the voltage at the diode output A exceeds a threshold voltage.

[0073] Thus, the voltage at the diode output A representing the continuity state of a container or product packaging on which the electronic device is attached or secured can be differentiated by observing, monitoring and/or measuring the duration of the voltage at the diode output A. Other techniques for differentiating between the continuity sensor output and the wireless (e.g., RF or NFC) field include amplitude modulation (e.g., detection of a signal having a different amplitude), frequency modulation (e.g., detection of a signal having a different frequency), switching (e.g., the diode output A, which may be connected to an NFC communication circuit under normal operation, may be periodically disconnected from the NFC communication circuit and temporarily connected to the sensor while the first [red] coil **510** is being driven), and relative measurement (e.g., detecting the rising edge that occurs when the first [red] coil **510** is initially driven). Whereas the NFC interrogation may be few seconds at most, the “open” state of the container or product packaging generally lasts longer than the NFC interrogation (e.g., frequently for at least tens of seconds, and in some cases, permanently). Usually, the occurrence of an NFC interrogation and the opening of the container or product packaging do not occur simultaneously, and are thus assumed to be separate or mutually exclusive events.

[0074] If the handheld device is brought in proximity to the electronic device and/or continuity sensor during the time that oscillation occurs in the coil-transistor loop due to an “open” continuity state, there will be a collision between electromagnetic signals (e.g., in the coil-transistor loop), and the NFC interrogation will fail. To mitigate this scenario (and conserve battery power in embodiments including a battery), the gain control signal is not a DC signal, but rather, a sequence of pulses having a predetermined duty-cycle. The duty cycle (e.g., 50% on, 50% off in each cycle) provides time intervals when the oscillation in the loop stops. During these intervals, an NFC interrogation can succeed.

[0075] In an alternative embodiment, the above-described properties of the three-coil system can be used to induce positive feedback resulting in a change in state of the bistable electronic device. In addition, the present continuity sensor can work in a complementary fashion (i.e., the closed state may correspond to relatively strong coupling and a relatively strong signal [i.e., a “high-coupling state”], and the “open” state may correspond to relatively weak coupling and a relatively a weak signal [i.e., a “low-coupling state”]). However, in oscillation-based embodiments of the electronic device that include a battery, such a complementary

continuity sensor may cause a constant current drain from the battery. Thus, the complementary continuity sensor may be more suitable for a bistable sensors in electronic devices that extract power from a received wireless signal (e.g., in which one coil/antenna is coupled to an integrated circuit that includes a rectifier).

[0076] FIG. 9 shows an exemplary four-coil continuity sensing system 600 according to one or more embodiments of the present invention, in which an auxiliary (or compensation) coil 640 is added to a three-coil system comprising moving coil 610 and stationary coils 620 and 630. Each of the moving coil 610 and stationary coils 620 and 630 includes first and second terminals 612a-b, 622a-b and 632a-b, respectively, configured for electrical attachment (directly or indirectly) to an IC (not shown). The coils 610, 620 and 630 are connected to an IC and/or discrete component (such as a capacitor) through bond pads 616, 626 and 636, respectively. The second (outer) terminals 612b, 622b and 632b are electrically connected to one of the bond pads 616, 626 and 636 (other than the first terminal 612a, 622a and 632a) by a strap 614, 624 and 634, respectively. Typically, the straps 614, 624 and 634 are isolated from the coils 610, 620 and 630 by an insulation layer, which may comprise a plastic, a glass, a ceramic or other electrical insulator. The bond pads 616, 626 and 636 other than those connected to a coil 610, 620 or 630 may be connected to traces that electrically connect one or more other components, such as a battery, an external sensor, one or more resistors and/or capacitors, a display, etc. to the IC. The first terminals 612a, 622a and 632a and the bond pads connected to the second terminals 612b, 622b and 632b may also be connected to one or more traces that electrically connect another component to the IC.

[0077] The auxiliary loop 640 is configured to reduce a low residual coupling that may be present between the second stationary coil 630 and the first stationary coil 620, and may further compensate for the impedance of the second stationary coil 630. The auxiliary loop 640 may have dimensions and/or a number of loops sufficient to provide a predetermined or desired amount of impedance compensation. The auxiliary loop 640 is connected to the second stationary coil 630 by a first trace 645a and to an IC (not shown) by a second trace 645b, a terminal 642, and a strap 644 (which is isolated from the first and second traces 645a-b by an insulator, as described herein). In the absence of the auxiliary coil 640, there may be some unintentional coupling between the first and second stationary coils 420 and 430. The unintentional coupling tends to reduce the sensitivity (e.g., of the first and second stationary coils 420 and 430) to the presence of the moving coil 410, and the moving coil 410 has to first overcome any unintentional coupling to create a significant change in the second stationary coil 430. The auxiliary loop 640 may reduce this unintentional coupling, and consequently enhance sensitivity of the system to the presence of the moving coil 410 as it approaches the second stationary coil 430.

[0078] FIG. 10A is a graph showing the correlation between experiment and simulation for detection of a closed state in an example of the present continuity sensor containing the 3-coil system 410, 420 and 430 and the auxiliary coil 640 in FIG. 9, secured to a product container having a cap or lid that opens angularly (i.e., by pivoting on a spindle, rod or other connection between the cap/lid and the body of the container). The plotted data show the impedance (in

ohms) of the first stationary coil 420 as a function of the angle of the moving coil 410 relative to the first stationary coil 420. The effect of the auxiliary coil 640 is always present.

[0079] FIG. 10B shows the gain between port 1 and port 2 (see, e.g., FIG. 5) for open-state detection of the same system as that for which the test results in FIG. 10A were obtained. FIG. 10B shows increased coupling (e.g., between the first and second stationary coils 420 and 430) as a function of the angle of the moving coil 410 relative to the first stationary coil 420. The effect of the auxiliary coil 640 is always present.

[0080] There is no change in permeability as the angle of the moving coil 410 relative to the first stationary coil 420 changes, or during closed-state vs. open-state detection. No ferro- or ferrimagnetic material is present. In the open state, the moving coil 410 couples an oscillating signal from the first stationary coil 420 to the second stationary coil 430, resulting in a signal on the second stationary coil 430 sufficiently strong to generate an “open state” flag. During the closed state, the moving coil 410 loads the first stationary coil 420 sufficiently to reduce the effective impedance seen by a transistor providing a bias to the output of the first stationary coil 420 (e.g., transistor 742 in FIG. 11), resulting in a reduced RF voltage at the drain of the transistor. This way, the sensitivity to the angle (or distance) variation between the moving coil 410 and the first stationary coil 420 around the thresholds for detecting the closed and open states can be achieved. The auxiliary coil 640 is not limited to the particular embodiment described herein, but may be deployed in other embodiments and may vary in location and/or structure as will be understood by the skilled person in the art.

[0081] FIG. 11 shows an exemplary integrated circuit (IC) 700 for use in conjunction with a further example of the present 3-coil continuity detector 500'. Similar to the continuity detector 500 in FIG. 8, the continuity detector 500' includes a first moving coil 510, a first capacitor 512 connected to a terminal of the first coil 510, a second “closed state” coil 520, a second capacitor 522 (which may be part of the integrated circuit 700) connected to a terminal of second coil 520, a third “open state” coil 530, and third and fourth capacitors 532 and 534 connected to a terminal of the third coil 530. The first coil 510 moves between the position shown, which corresponds in this example to an open state of the container or packaging, and a position rotated counterclockwise from about 60° to about 120° (and in one example, about 90-100°), corresponding to a closed state of the container or packaging. Alternatively, the first coil 510 may moves between the position shown and a position parallel or substantially parallel with the second coil 520.

[0082] The IC 700 includes a first continuity state detector and closed state logic 710, load modulation logic 720, an RF oscillator 730, a bias circuit 740, and an amplifier, second continuity state detector and open state logic 750. The first continuity state detector and closed state logic 710 receives an output signal from the second coil 520, an output signal from a load modulation switch 712, and a periodic (e.g., clock) signal from a digitally-controlled oscillator (DCO; not shown). A bias 745 is also applied to the first continuity state detector and closed state logic 710 by the bias circuit 740 and a transistor 742. The periodic signal from the DCO is also received by the RF oscillator 730 and the amplifier, second continuity state detector and open state logic 750.

[0083] During operation of the IC 700, the transistor 742 is biased in saturation mode by the DCO, the output of which is received by the bias circuit 740. The DCO may also be a low power oscillator (LPO). Otherwise, the transistor 742 is turned off by the DCO. The signal output signal from the second coil 520 (biased by the bias circuit 740 and transistor 742), is modulated (e.g., has its amplitude reduced) when the load modulation switch 712 is closed. The load modulation switch 712 is closed and opened by the output of the load modulation logic 720.

[0084] In the closed state, the first coil 510 is rotated towards the second coil 520, and the signal output from the second coil 520 is relatively high. Thus, the detector and logic in the first continuity state detector and closed state logic 710 may comprise a threshold detector that outputs an active “closed state” flag 715. In addition, the first continuity state detector and closed state logic 710 may output a signal (“Vdd for Wireless TX”) to wireless communication circuitry, such as a modulator (see, e.g., FIG. 19), for wireless transmission to an external receiver. The signal may comprise a power supply or a data signal, and the wireless communication circuitry may output an amplitude-modulated signal.

[0085] In the open state, the first coil 510 couples the signal from the second coil 520 to the third coil 530, resulting in an output signal 535 having sufficient strength to generate an “open state” flag from the amplifier, second continuity state detector and open state logic 750. During the closed state, the first coil 510 loads the second coil 520 sufficiently to reduce the effective impedance seen by transistor 742, resulting in a reduced RF voltage at the drain of transistor 742. This creates the “closed state” flag 715. In this manner, the continuity sensor 500 may have increased sensitivity to variations in the angle between the first coil 510 and the second and/or third coils 520 and/or 530 around the thresholds for the closed and open states (and, when there is a gap between the thresholds for the closed and open states with no overlap between the closed and open states, the thresholds for a “partially closed” or “partially open” state between the closed and open states).

[0086] In some embodiments, each of the stationary coils is associated with an independent integrated circuit (IC). For example, a first IC is electrically connected to the first stationary coil, and a separate second IC is electrically connected to the second stationary coil. Each of the first and second ICs may be a printed IC (PIC). In the example of FIG. 11, the first IC is electrically connected to the second coil 520, and the second IC is electrically connected to the third coil 530.

[0087] Generally, the first and second ICs may include an oscillator (e.g., a low power oscillator), an open or closed state sensor and/or detector, and a controller (a microcontroller or control logic circuit). One or both of the first and second ICs may include a memory (e.g., a non-volatile or one-time programmable [OTP] memory comprising a plurality of memory cells or elements) and a memory write (or programming) circuit. The first and second ICs may have the same or a different configuration.

[0088] In further embodiments, the second IC (connected to the second stationary coil 530) may include a real-time sensor or timer circuit, a memory and a controller configured to (i) record the time at which the device was opened and (ii) determine if a sample of the product was taken or the device was actually used each time that the container or package

was opened. In one example, the controller determines if a sample was taken or the device was used through an app (e.g., on a programmed NFC reader, such as a smart phone) that reads the memory (or the part thereof) that stores the continuity sensor output (e.g., using an NFC protocol).

[0089] FIGS. 12A-B show an alternative solution for the integrated circuitry to be connected to the first and second stationary coils. FIG. 12A shows a first printed IC (PIC) 800, and FIG. 12B shows a second PIC 900. One or both of the first and second PICs 800 and 900 may be manufactured by printing a doped polysilane (PDPS) ink to form semiconducting features or structures in the PIC.

[0090] Referring to FIG. 12A, PIC 800 contains open and closed state sensor/detector blocks 810 and 820, a main controller 830, a low power oscillator 840 configured to help the controller 830 manage power and count time slots (e.g., points in time when the container or package is opened), and a wireless (e.g., NFC) modulator 860. The MCU 830 can also control memory read and write operations and frame or information packet generation. The controller 830 also interfaces with a controller on the second PIC 900, which manages write and read operations of all memories, dynamically generates error codes (e.g., cyclic redundancy check [CRC] code), assembles the frame or information packet to be transmitted wirelessly, and serially transmit the frame or information packet to the NFC modulator 860 in the first PIC 800, which then communicates wirelessly with the reader (not shown).

[0091] The first PIC 800 may perform any of a number of tasks. For example, the first PIC 800 may assist the first stationary (“red”) coil to perform its role in the three-antenna sensor system (e.g., system 400 in FIG. 5 or system 500 in FIG. 8) and communicate wirelessly with a scanner and/or reader. A crystal oscillator 850 on the first PIC 800 may energize the first stationary coil (or antenna) during the “closed state” detection mode or process, and can provide a link from the wireless reader to the sensor system using a wireless protocol in the memory read mode (e.g., during a memory read operation).

[0092] During closed state detection, the degree or extent of coupling between the first stationary coil and the moving (“blue”) coil or antenna changes the load impedance of the amplifier 812 receiving the output of the first stationary coil that is amplified by the amplifier 812 and detected by the closed state envelope detector 814. This is shown in the closed state detector block/module 810. Similarly, during open state detection, the degree or extent of coupling between the first stationary coil and second stationary (“green”) coil or antenna via the moving coil is amplified by the amplifier 822 receiving the output of the second stationary coil and detected by the open state envelope detector 824. This is shown in the open state detector block/module 820. The amplifier gains are directly proportional to the respective impedances, and the peak voltage swings are detected by the respective closed and open state envelope detectors 814 and 824. The DC voltages from the envelope detectors 814 and 824 are compared against one or more pre-set references by the slicers 816 and 826, respectively, to generate the signal output by the slicers 816 and 826.

[0093] The first PIC 800 may read an incoming wireless (e.g., NFC) frame from the second PIC 900. For example, the memory 922 (FIG. 12B) may store an intended or prescribed usage pattern (e.g., a drug dose delivery regimen or schedule). When a memory read operation is initiated by

a wireless reader such as a smartphone, the read mode is detected, and the MCU **830** signals the auxiliary controller **910** on the second PIC **900** to read the memory **922**. Error checking code (e.g., CRC) is added to the data from the memory **922** by error code block **934**, and the serial data from the second PIC **900** is then encoded and modulated by the encoding module **936** (e.g., as per an NFC protocol). The encoding module **936** may also encode and modulate the serial data from the second PIC **900** according to a second wireless protocol, such as a “tags-talk-first” (TTF) protocol.

[0094] The first PIC **800** may include the main controller **830** for the overall continuity sensing system, and may interface with the auxiliary controller **910** of the second PIC **900**. The first PIC **800** may provide power management for the continuity sensing system using a low power oscillator **840** to power various blocks during different cycles or operations. The first PIC **800** may also perform a time keeping function by providing one or more timing signals (e.g., a real-time signal, with a frequency of, e.g., 1 Hz) to the second PIC **900**, which manages (e.g., records and reads out) time slots using the memory write module **924**, the memory **922**, and the memory read circuitry **932**.

[0095] The parameters of the low power oscillator **840** may be determined from the capacity of the battery (not shown) after self-discharge, the standby leakage current for the entire continuity sensing system, the power consumption when the continuity sensing system is active, the duration of time during which the continuity sensing system is in a standby state and is active (e.g., for an expected period of use, such as one month, 60 days, 90 days, 1 year, etc.), and the duty cycle (e.g., the ratio of active operation time to standby time).

[0096] In various embodiments, the oscillator variation over temperature, battery drop (e.g., output voltage decrease over time) and aging is within 1.0% or less (e.g., within 0.6%, 0.4%, etc.) to minimize or control a total error (e.g., in the real-time clock function). When the operating frequency is below a certain threshold, trimming the oscillator (e.g., coupling the oscillator signal or a bias to the oscillator with one or more resistors and/or capacitors) to a relatively high accuracy (e.g., 0.25%) may be challenging and may consume more area than is desired. However, to keep the frequency of the oscillator **840** within desired limits over power supply and temperature variations, a frequency correction loop that monitors the frequency of the oscillator **840** and corrects it to within an acceptable range (e.g., the desired limits) may be included.

[0097] FIG. 13A shows a circuit diagram of a relatively simple two-inverter RC oscillator **840-A** suitable for use as the low power oscillator **840** in the IC **800** of FIG. 12A. The RC oscillator **840-A** includes a first inverter **inv1**, a second inverter **inv2**, a capacitor **C** in series with the first and second inverters **inv1** and **inv2**, and a resistor **R** connected to (i) the node **V1** between the first and second inverters **inv1** and **inv2** and (ii) a node **V1** (e.g., the input to the first inverter **inv1** and/or a terminal or electrode of the capacitor **C**). The other terminal or electrode of the capacitor **C** is connected to the output **V2** of the second inverter **inv2**.

[0098] The two-inverter RC oscillator **840-A** can generate a periodic signal with a relatively low frequency (e.g., in the range of 0.1 Hz-1.0 kHz) using the resistor **R** and the capacitor **C**. The period (i.e., the reciprocal of the frequency) of the oscillator **840-A** can be calculated according to Equation [1]:

$$\text{Oscillator Period} = RC \cdot \ln \frac{V_T + V_{DD}}{V_T} + RC \cdot \ln \frac{V_T - 2V_{DD}}{V_T - V_{DD}} \quad [1]$$

where V_{DD} is power supply voltage to the oscillator, V_T is the threshold voltage at which the inverters **inv1** and **inv2** switch output states, **R** is the resistance of resistor **R**, and **C** is the capacitance of capacitor **C**.

[0099] The frequency of the oscillator **840-A** is directly proportional to **R** and **C**. To reduce power consumption and generate a periodic signal having a relatively low frequency (e.g., on the order of 0.1-10 Hz) using the oscillator **840-A**, the resistor **R** and the capacitor **C** may be external to the integrated circuit **800** (FIG. 12A) to create a large time constant. Placing the resistor **R** and the capacitor **C** on the substrate or die of the integrated circuit **800** may cause the integrated circuit **800** to have a larger area than desired (e.g., for the dimensions and/or aesthetics of the product packaging). The accuracy of the oscillator **840-A** may be controlled by the tolerances of the resistor **R** and the capacitor **C**, which may be less challenging when they are external to the integrated circuit **800**. The frequency of the oscillator **840-A** is dependent on the ratio V_T/V_{DD} , which may be trimmed in the integrated circuit **800**. This ratio changes as a function of supply voltage (i.e., V_{DD}), as the switching threshold of the inverters **inv1** and **inv2** does not scale or change with changes in V_{DD} . To trim the frequency of the oscillator **840-A**, a capacitor bank may be included in parallel with the capacitor **C**, and one or more of the capacitors in the capacitor bank may be included in the circuit **840-A** (e.g., using one or more switches connected to the capacitors in the capacitor bank) to produce a particular and/or desired frequency at a particular supply voltage.

[0100] A possible disadvantage of the oscillator **840-A** is that its charging and discharging currents may vary with the supply voltage. Accordingly, the oscillator **840-A** may consume greater power as the supply voltage increases. External resistor and capacitor components may also make the oscillator **840-A** relatively susceptible to electrostatic discharge (ESD) damage.

[0101] As the battery voltage drops, the frequency of the oscillator **840** (FIG. 12A) is affected. The frequency variation of the oscillator **840** can be mitigated by operating the oscillator at a fixed voltage that stays relatively constant as the battery drops, and can be controlled by regulating its supply voltage using a voltage regulator (e.g., a low-power, low-drop out regulator). The voltage regulator may provide a relatively constant DC voltage output (optionally at predetermined maximum load current, for example of 1-100 μ A). A conventional low-power reference voltage generator (which may receive a supply voltage from the battery) may be external to the IC **800**.

[0102] FIG. 14A shows a circuit diagram of a single-stage, low-dropout regulator **1000** that generates a relatively constant, fixed voltage at node V_{OUT} as the battery drops. The regulator **1000** comprises a fixed-current operational amplifier (OP-AMP) **1010** in a feedback loop **1020** that controls a p-channel transistor **1030**. The regulator **1000** is configured to regulate a predetermined output voltage (V_{OUT}) of, e.g., 1.5-3.3V. The output V_{OUT} of the regulator **1000** decreases logarithmically with increasing DC load current. However, in an embodiment configured to regulate to an output voltage of 2.5V, the output V_{OUT} of the regulator

1000 was within $\pm 0.1V$ over a DC load current from 10% of the maximum load current to the maximum load current.

[0103] Power consumption by the regulator **1000** may be reduced or minimized by keeping the bandwidth of the regulator **1000** relatively low (<100 kHz, <10 kHz, <1 kHz, etc.). Signals with relatively fast transitions generally require a relatively high bandwidth response. The currents for such fast-transitioning signals may be provided by an external load capacitor (not shown). A possible disadvantage of the regulator **1000** is that it may consume power (e.g., continuously) during its operation.

[0104] An alternative regulator **1050** (e.g., a single-stage, adaptive biasing or adaptive-biased low-dropout regulator) is shown in FIG. **14B**. The adaptive biasing alters the tail current of the error amplifier (transistor M_p) in accordance with the load current (e.g., I_p). As a result, the regulator **1050** achieves better regulation than fixed-biased, single-stage topologies. One advantage of the regulator **1050** over multiple-stage low-dropout regulators is that the regulation loop (e.g., output V_o controlling the gate of transistor M_3) can be easily compensated. The regulator **1050** is configured to regulate an output voltage V_o of 1.0-3.0V, with maximum DC load current of 5-20 μA .

[0105] FIG. **13B** shows a circuit diagram of an alternative oscillator (e.g., an I-C oscillator) **840-B**. The circuit includes a start-up block **842**, a current reference block **844**, a charge/discharge sensing block **846**, and a clock generation block **848**. For low-power operating currents, the oscillator **840-B** is configured to operate alternately as a current source and as a current sink in the sub-threshold region. The current reference block **844** may be trimmed (e.g., for offsets caused by process variations) using a trimming resistor R trimming, which controls the power consumption of the oscillator **840-B** and which may be internal to the IC **800**. A capacitor C trimming, which may be external to the IC **800** and which may be in parallel with an internal capacitor array, is electrically connected to the sensing node V_C to trim the frequency of the oscillator **840-B**. The reference current (**I4-I5**) charges the node V_C . When V_C is above the threshold voltage of transistor $M1$, the output of the inverters INV shuts off the reference current to the capacitor $C_{trimming}$. At this point, the voltage V_C is discharged by the sink current source **I5**. The frequency of the oscillator **840-B** can be calculated according to Equation [2]:

$$\text{Frequency} = \frac{V_R}{2RC\Delta V_C} \quad [2]$$

where R is the resistance of the resistor $R_{trimming}$, C is the capacitance of the capacitor $C_{trimming}$, and ΔV_C is the charging/discharging voltage across the capacitor $C_{trimming}$.

[0106] The frequency of the oscillator **840-B** is directly proportional to the resistance R and the capacitance C . It may be important to select and/or manufacture resistor and capacitor components with tight tolerances to meet any requirements for high accuracy of the oscillator **840-B**. The frequency of the oscillator **840-B** is also dependent on ΔV_C , which may be trimmed on chip and/or off-chip. The frequency of the oscillator **840-B** is typically independent of the supply voltage (e.g., to a first order), which may reduce or eliminate the benefit(s) of a low-dropout regulator. The power consumption of the oscillator **840-B** is also generally

independent of the supply voltage. One disadvantage of the oscillator **840-B** may be that the voltage swing on the charging and discharging node V_C is relatively small, which can result in an undesirably low signal-to-noise ratio. Also, if an external capacitor is used in the capacitor $C_{trimming}$, it may be somewhat prone to ESD.

[0107] A further alternative low-power oscillator (e.g., a multi-stage current-controlled ring oscillator) **840-C** is shown in FIG. **13C**. The current-controlled ring oscillator may have any odd number of stages **845a-x** greater than or equal to 3. The bias current I_{D4} to the inverters (e.g., $M2$ and $M3$) is controlled by a bias or voltage generator that may be external to the chip **800**.

[0108] The input voltage V_{invCO} to the transistor $M5$ controls the bias current I_{D4} to the inverters. The bias current I_{D4} to the inverters limits the charging and discharging currents, which in turn makes the power consumption of the oscillator **840-C** independent of the supply voltage (e.g., VDD). The frequency of the ring oscillator **840-C** may be calculated according to Equation [3]:

$$f_{osc} = \frac{I_D}{NV_{DD}C_{TOT}} \quad [3]$$

where N is the number of stages, VDD is the supply voltage, and C_{TOT} is the total capacitance at the output of each inverter. One possible disadvantage of the oscillator **840-C** is that the frequency is dependent on the supply voltage VDD , as shown in Equation [3]. The oscillator **840-C** may also benefit from a voltage regulator (e.g., to provide VDD and/or V_{invCO}). One advantage of the oscillator **840-C** is that its components can be included completely in the IC **800**.

[0109] FIG. **15** shows a block diagram of exemplary components for exemplary closed and open state detectors **810** and **820**, similar to those shown in FIG. **12A**. The closed and open detectors **810** and **820** may share some circuit elements, although the invention is not limited thereto.

[0110] In the path of the closed state detector **810**, the output of a crystal oscillator **880** is amplified by an amplifier **850**. A tank capacitor **855** receives the amplified crystal oscillator signal, and the output of the tank capacitor **855** is converted to a multi-bit digital signal with a digital-to-analog converter (DAC) **890**. The DAC **890** may have a resolution of at least 2 bits (e.g., 3 to 10 bits), but can be relatively simple (e.g., on the order of 5 bits). Thus, the crystal oscillator **880** effectively drives the amplifier **812** for the first stationary coil **420** in the closed state detector **810** with a constant amplitude (e.g., and at a predetermined frequency, such as 13.56 MHz). This process is unaffected by any coupling between the first stationary coil **420** and any other coil.

[0111] Thus, the present continuity sensing system may comprise a standard Pierce oscillator. The amplifier **850** may have the highest gain possible that does not saturate the output of the amplifier **812**. This may be achieved by adjusting level(s) of the bias to the amplifier **812**, which allows the amplifier **812** to successfully detect a closed state (e.g., when the impedance of the tank capacitor **855** changes due to coupling changes in the coils **410**, **420** and/or **430**). As a result, the amplifier **850** may have a minimum and/or maximum output voltage of 0.8-3.3V (e.g., 1.0 to 2.5 V) at a predetermined frequency (e.g., 13.56 MHz). The gain of

the amplifier **850** may be at least 4 times (or, alternatively, at least a minimum increase, such as greater than 8, 10 or 12 dB) when the phase of the periodic signal from the crystal oscillator **880** crosses 0, a measure of positive feedback and oscillatory behavior.

[0112] The first stationary coil **420** is a load for the amplifier **812**. The distance of the moving coil **410** from the first stationary coil **420** changes the coupling between these coils. A change in coupling between the moving coil **410** and the first stationary coil **420** results in different reflected impedances seen by the amplifier **812**. The gain of the amplifier **812** is directly proportional to this impedance. The output voltage swing of the amplifier **812** is a function of the distance or angle between the moving coil **410** and the first stationary coil **420**.

[0113] The output of the amplifier **812** in the closed state detector **810** is capacitively coupled to a second digital-to-analog converter **813**. The digital signal from the second digital-to-analog converter **813** is received by an envelope detector **814** that detects the peak of the digital signal, and the resulting DC voltage is compared against a reference voltage (e.g., from a third DAC **817**) in a comparator **818** to generate the final closed/not closed state output. The closed/not closed state output is stored in a latch **819** (e.g., for output as a closed state signal or flag).

[0114] The open state detector **820** works on a transmission mode principle, where the strength of the signal transmitted from the first stationary coil **420** to the second stationary coil **430** via the moving coil **410** varies as a function of the distance between the moving coil **410** and the second stationary coil **430**. Based on the distance between the moving coil **410** and the second stationary coil **430**, the strength of the received signal at the second stationary coil **430** varies. The tank amplifier **822** for the second stationary coil **430** and the circuit blocks downstream therefrom may be configured to provide gain to signals having an amplitude greater than a certain or predetermined threshold.

[0115] The threshold for signals to be amplified by the amplifier **822** may be aligned to the distance or angle between the moving coil **410** and the second stationary coil **430**. Thus, as the second stationary coil **430** and the moving coil **410** couple more strongly, the output signal starts to toggle. The presence of a toggling signal indicates an open state. A static high or low signal indicates a not open state.

[0116] The amplifier **812** for the first stationary coil **420** may be important to the performance of both the closed and open detectors **810** and **820**. The amplifier **812** may be biased to keep it from saturating, so that information about the closed state and the “not closed” state can be detected. A saturated amplifier output may be unable to distinguish between the two states.

[0117] The amplifier **812** may consume the most power of all of the circuit blocks in FIG. 15, and power management of the amplifier **812** may be beneficial to prolonging the life of the battery. Amplifier gain depends on its bias current. A large and stable gain under varying operating conditions (e.g., load impedances) provides a wide detection window. Detection of closed and open states relies on a changing impedance of the load on the capacitor **855** and/or the capacitor **815** as the coupling between the first stationary coil **420** and the moving coil **410** changes.

[0118] The output of the amplifier **812** is converted to a DC value (e.g., by the DAC **813**) for input to the envelope

detector **814**. At particular frequencies (e.g., 13.56 MHz), the output of the amplifier **812** may include some ripple. The envelope detector **814** may comprise a diode and a capacitor. The impedance of the diode and the capacitor in the envelope detector **814** may control the transient performance of the envelope detector **814**.

[0119] The input to the envelope detector **814** may be trimmed (e.g., by the DAC **813**, which may have a resolution of from 3 to 7 bits) and compared to a pre-set reference (e.g., the output of a relatively high-resolution DAC **817**, which may have a resolution of from 6 to 12 bits) by a comparator **818**. The comparator **818** may comprise a high-gain amplifier that senses the DC voltage output from the envelope detector **814**. The comparator **818** uses the reference signal from the DAC **817** to “slice” between closed and not closed states.

[0120] The ripple on the DC voltage from the amplifier **812** may reduce the margin available to the comparator **818** for detection of the closed state. This ripple is inversely proportional to the RC value (e.g., of the amplifier **812** and/or circuitry between it and the crystal oscillator **880**). To reduce this ripple and improve detection margin, the ripple should be relatively small.

[0121] The time during which the closed state and open state detectors **810** and **820** are active (e.g., turned on) may be as small as possible to reduce current consumption and improve battery life. The active mode time of the closed state and open state detectors **810** and **820** may be, for example, from 1 to 50 ms, or any value or range of values therein.

[0122] However, if the detector **810** is turned on for a short interval, then the output of the envelope detector **814** may not be fully developed, and the state detection could be erroneous. On the other hand, if the detector **810** is turned on for a longer duration, the detection accuracy is better. Since the envelope detector **810** may consume a relatively large amount of current, the envelope detector **814** turn-on time is a tradeoff between accuracy and battery life. Simulations of the accuracy of the envelope detector **814** as a function of time help to determine an optimal active mode time for the state detector **810** (which is included in the above active mode time range).

[0123] The amplifier **822** for the second stationary coil **430** is configured to convert input signals corresponding to an open state into an output signal that can be detected. The output signal is periodic in accordance with the coupling frequency and is ideally a square wave. The amplifier **822** for the second stationary coil **430** amplifies an open state signal, but rejects (does not amplify) a “not open” state signal, from a previous stage (not shown, but which detects the open vs. not open states, and which may comprise a comparator similar to comparator **818** in the closed state detector **810**). The amplifier **822** may comprise multiple gain stages. The output waveform (e.g., at 13.56 MHz) from the amplifier **822** may be divided down in frequency by divide-by-n circuit **825** for ease of evaluation and measurement.

[0124] A multiplexer **870** (FIG. 12A) may select for output on or through the first stationary antenna **420** (i) an output of the open state detector **820** or the closed state detector **810**, or (ii) the wireless (e.g., NFC) communication modulator **860** to a reader (e.g., a smart phone). In absence of the wireless communication field, the open state detector **820** and the closed state detector **810** are typically activated at or after a fixed time interval (e.g., every second, every 15

seconds, every minute, every hour, every day, etc.) to check the continuity state of the package or container. Logic in the IC (e.g., IC 800 of FIG. 12A) can determine the presence of an external wireless frequency source, and shuts off or deactivates the open state/closed state detectors 810/820 upon detecting this frequency of radiation. The multiplexer 870 (which may comprise a plurality of low on-impedance switches) may be configured to switch or enable the first stationary antenna 410 (e.g., FIG. 15) only to communication wirelessly at this time or in this state. The main controller 830 of the IC 800 may activate the second IC 900 and receive a data stream from the second IC 900. The data stream from the second IC 900 (which may comprise a data frame or data packet) is transmitted to the reader by the first IC 800 via the first stationary coil 410 using a conventional wireless communication (e.g., the Tag Talks First, or TTF) protocol. The data may be encoded using a convention encoding scheme (such as On-Off keying and/or Manchester encoding) before transmission.

[0125] A block diagram for the second IC 900 is shown in FIG. 12B. The second IC 900 has three power domains. An auxiliary control unit 910 is in the battery power domain, a memory write module 924 (which may comprise a plurality of memory write circuits) and the memory 922 are in a “Battery++” power domain, and the memory read circuits 932 and the wireless communication data processing logic 934 and 936 are in the VDD domain 930.

[0126] The second IC 900 may provide any of a number of functions. For example, the second IC 900 may manage and/or process time slot information (as described herein) alone or together with the first IC 800. The second IC 900 may write data to the memory 922 when an event (e.g., a change in the continuity state of the package or container) is detected. The second IC 900 may read different memory elements (e.g., in response to different memory addresses being provided to the auxiliary control 910) and assemble a wireless data frame or packet. In some embodiments, the first IC 800 initiates a memory read operation. The second IC 900 may also read a memory space or address that stores unique ID information, and assembles a correctly sequenced data stream e.g., a data frame) for transmission to the first IC 800. The second IC 900 may dynamically (e.g., in real time) determine error correction code (e.g., the CRC code) when a read operation is initiated. The second IC 900 may also calculate and/or update the CRC as product usage data (e.g., a cumulative number of open and closed states) is recorded in the memory 922. The second IC 900 may output a data package for wireless communication in a serial format to the first IC 800 for encoding and/or modulation, or may perform either or both of the encoding and modulation functions itself. The second IC 900 may synchronize its operations with those of the controller 830 in the first IC 800 to keep the overall system synchronized.

[0127] In some embodiments, a memory read operation is initiated (e.g., by the main controller 830) when a reader is in the vicinity (e.g., within 3-10 meters, 3-10 cm, etc.) of the first stationary coil 410 (e.g., FIGS. 5, 8, and 15). The memory read operation can be initiated even if the battery is depleted or discharged. When the reader energizes the first IC 800 (e.g., by power extraction using the first stationary coil 410 and a rectifier coupled thereto), the main controller 830 may generate and transmit to the second IC 900 (i) a supply voltage sufficiently high for at least the memory 922, the memory read circuits 932, and the data processing

circuits 934 and 936 to perform the memory read functions and (ii) a periodic (e.g., clock) signal for the memory read functions. Once the supply voltage and periodic signal are received by the second IC 900, the second IC 900 initiates a memory read operation (e.g., according to a standard wireless communication protocol). The data package (or payload) may be divided between identification information (which may be hardcoded in the second IC 900 using laser-blown fuses), information in the memory 932 (which may include open state and closed state information), and error code (which may be calculated using a standard algorithm). The error code may be generated every time a read operation is performed because the information stored in the memory 922 may have changed since the most recent read operation. In some embodiments, the entire memory 922 is read and serially transported to the first IC 800, where the data are encoded and modulated for transmission to the reader.

[0128] The main controller 830 is in the first IC 800. The control bus (not shown; e.g., between the first and second ICs 800 and 900, or in the continuity state sensing system) encodes the state of the main controller 830 in the first IC 800, the state of any error flags, and the state of the auxiliary controller 910 in the second IC 900. The first IC 800 and the second IC 900 are synchronized using this bus so that each IC is in the correct state during operation.

[0129] On system start-up, the second IC 900 initializes a memory address counter (e.g., in the read circuits 932) to a start bit (e.g., a first addressed bit in the memory 922), writes to a start flag location, and moves the memory address counter to the next location (address) in the memory 922. Every time an open state is detected, a corresponding bit in the memory 922 is written, and the address counter (e.g., an “open state” address counter) is incremented. The “open state” address counter may also be incremented at the end of a predetermined time period (e.g., every hour, every 8 hours, every day, etc.) without writing to a corresponding memory bit. The portion of the memory and an address counter corresponding to closed state detection can operate similarly or identically. This allows the system to keep a record of open state and closed state detections (and, optionally, the time and/or time periods in which such detections were made). In some embodiments, the present continuity state sensing system may record a maximum number of open and/or closed states, or a maximum length of time of operation, in which case it sets an “end-of-life” flag and writes to the memory location corresponding to the flag.

[0130] The memory write circuits 924 may use the battery voltage to pump up the voltage to a “Battery++” level. In other words, if the battery voltage is x V, then the “Battery++” voltage is $>x$ V (e.g., $\geq 1.2x$, $\geq 1.3x$, $\geq 1.5x$, etc.). When the memory comprises nonvolatile cells (e.g., one-time programmable cells, EPROM cells, etc.), a voltage greater than the battery voltage may be needed to write to the cell.

[0131] In some embodiments, the memory 922 comprises a non-volatile memory array that, along with programming circuits in the write module 924, allows storage of information at a level or resolution of a single bit. The memory 922 may be used to store time stamps of open/closed state detection events, as well as the data itself. In one embodiment, the memory 922 stores usage data (e.g., the number of sequential open state-closed state detection events), along with error flags (e.g., a “partially open” or “partially closed”

state, preceded and followed by the same continuity state) and other information that can be analyzed (e.g., by software) to determine compliance with product usage instructions.

[0132] For the write operation to nonvolatile memory to occur successfully, a voltage higher than the battery voltage is generated using a charge pump (e.g., charge pump **1110** in the exemplary nonvolatile memory programming circuitry **1100** in FIG. **16**). The charge pump **1110** may include switches controlled by a clock signal (e.g., CPCLK) to transfer charge (e.g., VBATT) from the battery (not shown) to a storage capacitor **1115** that develops the write voltage across its terminals. Upon receiving a write request (e.g., in the main controller **830**), a voltage is applied to program a nonvolatile memory (e.g., OTP) cells **1130a-n**. In some embodiments, programming comprises applying a voltage sufficiently high to break down a dielectric layer in the memory cell. Meanwhile, the storage capacitor rebuilds charge and is ready to transfer it into the next memory cell when a write request for that cell is provided (e.g., to the main controller **830**).

[0133] The control circuits for programming and/or writing to the nonvolatile memory **1130a-n** are shown in FIG. **16**. These circuits include the charge pump **1110**, the storage capacitor **1115**, and a control circuit **1120**. The nonvolatile memory **1130a-n** includes *n* individual nonvolatile memory cells, where *n* is an integer of at least 4 (e.g., 2^x , where *x* is an integer of at least 3), and each cell stores one bit of data. The nonvolatile memory **1130a-n** may be a single row or column of cells, or an array of 2 or more rows and 2 or more columns. The individual nonvolatile memory cells may be accessed by corresponding address signals.

[0134] In some embodiments, the frequency of the clock signal (e.g., CPCLK) may be varied with differing values of the storage capacitor. As a result, the voltage to program or write into a nonvolatile memory cell **1130a-n** may be programmable as well. The circuitry associated with programming the nonvolatile memory cells **1130a-n** may be active or turned on only for the duration of a read or write/program operation, during which time an enable signal may be provided to the circuit block **1100**. Power consumption from the battery may therefore be limited to the time interval when the enable signal is active.

[0135] An exemplary charge pump **1110** is shown in detail in FIG. **17**. The charge pump **1110** is configured to increase the voltage from the battery to a level sufficient to enable the write operation (e.g., program the nonvolatile memory cells **1130a-n** in FIG. **16**). The charge pump **1110** uses switches **mn1-8** and **mp1-8**, controlled by a clock signal (e.g., CLK and its complement, CLKB) to transfer charge from the battery (VBATT in FIG. **16**, VDD in FIG. **17**) to a storage capacitor **Cout**. Upon receiving an instruction to program one or more nonvolatile memory cells **1130a-n**, the charge stored on the capacitor **Cout** is transferred to the nonvolatile memory cell(s), and the voltage necessary to program the cell(s) (e.g., by breaking down a thin dielectric layer in the cell) is applied to the cell(s). The charge pump **1110** is configured to deliver a minimum programming voltage (e.g., at least 3V, 4V, 5V, etc., but > the battery voltage or VDD) and/or a maximum or excess current (e.g., up to 2 mA, 4 mA, 6 mA, etc.) for a short duration of time (e.g., 1-1000 ms, or any value or range of values therein). Upon delivery of the programming voltage, the impedance of the programmed memory cell **1130** is significantly reduced. Measurement of

the impedance may validate a successful programming operation. The PIC **900** (FIG. **12B**) also contains control circuitry (not shown) configured to regulate the charge pump voltage at a desired or predetermined voltage for the duration of the write operation.

[0136] Alternatively, a Dickson charge pump (not shown) may be used instead of the charge pump **1110** in FIG. **17**. The Dickson charge pump comprises a plurality of MOS switches (e.g., NMOS transistors connected in series between source/drain terminal of adjacent switches, the first of which is connected as a diode such that the input voltage is received at both a source/drain terminal and the gate), controlled by different phases of a clock signal (e.g., that are 180° apart). The clock signal may be provided by a clock generator that is external to the second IC **900**. The charge is transferred from one switch to the next and stored in intermediate “flying” capacitors (e.g., having one electrode receiving one phase of the clock signal and another electrode connected to the gate of a MOS switch), and finally into a storage capacitor that provides the programming voltage. The programming voltage in the Dickson charge pump depends on number of stages in the pump, the flying capacitors (e.g., the capacitances thereof), and the frequency of the clock.

[0137] In order to mitigate the potential impact of a breakdown voltage on the MOS switches in the Dickson charge pump, a modified Dickson charge pump may be used as shown in FIG. **17**. The gate-source and gate-drain voltages at the switches **mn1-8** and **mp1-8** are kept below the battery voltage VDD, even though the absolute voltage developed across each stage may increase by a factor of up to 2. However, the modified charge pump architecture shown in FIG. **17** may increase the number of capacitors *C* (each stage may include two capacitors *C*), thereby increasing the real estate consumed by the charge pump **1115**.

[0138] The charge pump **1110** may also include a buffer (not shown) driving the gates of the MOS switches **mn1-8** and **mp1-8**. In some embodiments, the buffer may comprise a plurality of inverter stages connected in series (i.e., the output of a first inverter is an input to a second inverter) and a logic gate (e.g., a NAND or AND gate) at an input of the plurality of inverter stages (e.g., receiving at least the clock signal CLK and an enable signal), where the plurality of inverter stages are configured to output the clock signal CLK and its complement CLKB. The buffers may be sized so that they can operate at high frequency (e.g., >500 kHz, 900 kHz, >13 MHz, etc.) and drive the gates of the MOS switches **mn1-8** and **mp1-8** close to the supply voltage VDD and ground to effectively transfer the charge across the switches. Any leakage in the capacitors *C* due to equivalent series resistance (ESR) may affect the output voltage *Vout*, and should be minimized to the extent possible under the circumstances.

[0139] Cyclic Redundancy Checking (CRC) is a technique for detecting (and optionally correcting) errors in digital data that may be transmitted as a long string of serial digital data bits. For example, the CRC code added by the dynamic CRC circuit **934** (FIG. **12B**) to the data from the read circuits **932** may comprise *p* bits (e.g., where *p* is an integer of at least 2, such as 4, 8, 10, 16, etc.), attached to a serial payload of *q* bits (e.g., where *q* is an integer of at least 60, 120, 180, 240, etc.). The sum of *p+q* may conform to a known protocol for wireless transmission of serial data (e.g., where $[p+q]=64, 128, 192, 256, \text{etc.}$). The dynamic CRC circuit **934** attaches

the CRC code to the data string using a standard polynomial. The receiver (e.g., a smart phone; not shown) validates an error-free transmission by applying the same polynomial to the received data and comparing the result to the received CRC code. In case of a discrepancy (a logic 0 or a logic 1 was received in error), the comparison (e.g., a CRC check) will fail, and the receiver will discard the incorrect data.

[0140] In a further embodiment, the continuity sensor may comprise the system **800'** shown in FIG. 18. The system **800'** comprises an external MCU **830'** that functions as the main controller (e.g., **830** in FIG. 12A), the present open state-closed state sensor **400/810/820**, a battery **835** and power management functionality. The power management functionality comprises a conventional power-on switch **836** that reduces or minimizes battery drain while the sensor is not in use. In a further embodiment, the power-on switch **836** can also electrically disconnect (e.g., turn off) the battery supply to the circuitry in the system **800'**. At least one of the circuits (e.g., the MCU **830'**) is configured to transmit signals in accordance with a wireless protocol (e.g., to read and/or report the time at which the package or container is opened). The MCU **830'** and the IC comprising the present open state and closed state detectors **810** and **820** are in different clock domains during operation. In at least one embodiment, the low power oscillator **840'** that provides one or more timing signals to the MCU **830'** may comprise an external resistor **847** and an external capacitor **849**. The components having an identification number identical to a component in another Figure operate identically or substantially identically to the component in the other Figure (as described herein).

[0141] FIG. 19 shows another exemplary integrated circuit **1200** for use in the present device. Some or all of the circuit and/or functional blocks in the exemplary integrated circuit **1200** can be present in the integrated circuit in any embodiment of the present invention. Additional circuit blocks, such as one or more display drivers, can also be included in certain embodiments.

[0142] The exemplary integrated circuit (IC) **1200** for use with the present security device includes one or more sensors (e.g., the present continuity sensor) **1210**, a threshold comparator **1220** receiving information (e.g., a signal) from the sensor(s) **1210**, a pulse driver **1240** receiving an output of the threshold comparator **1220**, a memory **1260** storing sensor data from the pulse driver **1240**, one or more bit lines (BL) **1272** for reading data from the memory **1260**, one or more sense amplifiers (SA) **1274** for converting the signal(s) on the bit line(s) to digital signals, one or more latches **1276** for temporarily storing data from the sense amplifier(s), and a transmitter (e.g., modulator) **1290** configured to output data (including an identification code) from the device. The exemplary IC **1200** in FIG. 12 also contains a clock (e.g., oscillator) **1250** configured to provide a timing signal (e.g., CLK) that controls the timing of certain operations in the IC **1200** and a memory timing control block or circuit **1270** that controls the timing of memory read operations. The modulator **1290** also receives the timing signal (CLK) from the clock circuit or a slowed-down or sped-up variation thereof. The exemplary IC **1200** may also include a power supply block or circuit **1280** that provides a direct current (e.g., VCC) to various circuits and/or circuit blocks in the IC. The memory **1260** may also contain identification code. The portion of the memory **1260** containing identification code may be printed. The IC **1200** may further contain a receiver (e.g., a demodulator), one or more rectifiers (e.g.,

a rectifying diode, one or more half-bridge or full-bridge rectifiers, etc.), one or more tuning or storage capacitors, etc. Terminals in the modulator **1290** and the power supply **1280** may be connected to ends of an antenna (e.g., at Coil1 and Coil2). The antenna may be a stationary (e.g., the second or third) coil, as described herein. In one embodiment, the IC **1200** further comprises one or more display drivers, and the battery **1230** and/or the power supply **1280** may be connected to one or more leads providing power to the display driver(s) and optionally a ground plane or other ground potential.

[0143] The memory in a wireless (e.g., an NFC or RF) security device may contain a fixed number of bits. In some implementations, an NFC tag may contain 128 or 256 bits. Some bits are allocated to overhead (non-payload) data for format identification and data integrity (CRC) checking. The payload of the wireless device consumes the remainder of the bits. For example, the payload can be up to 96 bits in the case of the 128-bit NFC tag and up to 224 bits in the case of the 256-bit NFC tag.

[0144] The payload of the NFC device can be allocated to variable amounts of fixed ROM bits (which are generally—but not always—used as a unique identification number). When print methods are used in manufacturing the NFC device, the ROM bits are permanently encoded and cannot be electrically modified. Any payload bits that are not allocated as fixed ROM bits can be allocated as dynamic sensor bits (e.g., for the continuity sensor). These sensor bits can change values, based on a sensed input. Different splits or allocations between ROM and sensor bits are indicated by data format bits that are part of the non-payload or ‘overhead’ bits, generally in the first 16 bits of the NFC tag memory.

[0145] One example of how continuity sensing may be implemented in the present invention involves a sensor **1210** that detects the voltage on a stationary coil, as described herein. The detected voltage is compared to a threshold voltage in the threshold comparator **1220**, which outputs a digital or analog value corresponding to a continuity state of the package or container, and the pulse driver **1240** stores the value in the memory **1260**. In a relatively simple example, when the voltage detected on the first stationary coil is equal to or greater than the threshold voltage of the “closed state” sensor, the package or container is closed, and when the voltage detected on the second stationary coil is equal to or greater than the threshold voltage of the “open state” sensor, the package or container is open. When the voltages detected on both stationary coils are less than the corresponding threshold voltages, the package or container is partially closed or partially open. Thus, one or more continuity state bits in the memory **1260** store a state that reflects the detected voltage(s). This indicates to the reader (e.g., an NFC smartphone, etc.) that the protected container is closed, open, or somewhere in-between. The ROM ID bits do not change, but any data integrity bits (e.g., for CRC) may be updated to reflect the continuity state of the package or container.

[0146] The IC **1200** in the present device may include one or more other sensors in addition to the continuity sensor(s). For example, the IC **1200** can further include one or more temperature sensors, humidity sensors, electromagnetic field sensors, current/voltage/power sensors, light sensors, and/or chemical sensors (e.g., for oxygen, carbon monoxide, carbon dioxide, nitrogen oxides, sulfur dioxide and/or trioxide,

ozone, one or more toxins, etc.). The present IC may also include one or more time sensors (e.g., configured to count or determine elapsed time), which may include the clock circuit (which can be a basis for a real-time clock) **1250** and one or more counters, dividers, etc., as is known in the art. Such sensors may be on the same substrate as the antenna (e.g., one of the stationary coils), the battery **1250** and/or the IC **1200**, or on a different substrate that is electrically connectable to the battery **1250** and the IC **1200**.

[0147] Each of the embodiments of the invention described with reference to the Figures may be modified by the disclosures connected to the other embodiments and/or by the other disclosures herein, including in the ‘Summary of the Invention’ section and the claims.

[0148] The foregoing descriptions of specific embodiments of the present invention have been presented for purposes of illustration and description. They are not intended to be exhaustive or to limit the invention to the precise forms disclosed, and obviously many modifications and variations are possible in light of the above teaching. The embodiments were chosen and described in order to best explain the principles of the invention and its practical application, to thereby enable others skilled in the art to best utilize the invention and various embodiments with various modifications as are suited to the particular use contemplated. It is intended that the scope of the invention be defined by the Claims appended hereto and their equivalents.

What is claimed is:

1. An electronic device, comprising:
 - a) a first substrate with first and second coils thereon, the first coil having an integrated circuit electrically connected thereto, and the first substrate being a first part of an article, container or product packaging or configured to be attached or secured to the first part of the article, container or product packaging;
 - b) a second substrate with a third coil thereon, the second substrate being a second part of the article, container or product packaging or configured to be attached or secured to the second part of the article, container or product packaging, wherein one of the first and second parts of the article, container or product packaging is removable or movable with respect to the other one of the first and second parts of the article, container or product packaging;

wherein

the first and second coils have a first coupling when the article, container or product packaging is closed or sealed, and a second, different coupling when the article, container or product packaging is open or unsealed.
2. The electronic device of claim 1, wherein the first and second coils are in fixed positions relative to each other.
3. The electronic device of claim 1, wherein the first, second and third coils form a continuity sensor, the continuity sensor senses or determines a continuity state of the container or product packaging.
4. The electronic device of claim 3, wherein the first coupling corresponds to a closed or sealed continuity state, and the second coupling corresponds to an open or unsealed continuity state.
5. The electronic device of claim 3, wherein the second coil is on a removable or movable one of the first and second parts of the article, container or product packaging, and the

movable one of the first and second parts of the article is repeatedly movable between the open and closed continuity states.

6. The electronic device of claim 3, wherein the first and second coils have a third coupling when the article, container or product packaging is partially open or partially closed, and the third coupling is between the first coupling and the second coupling.

7. The electronic device of claim 3, wherein the first, second and third coils form an open loop when the continuity sensor has the closed or sealed continuity state, and the third coil closes the loop when the continuity sensor has the open or unsealed continuity state.

8. The electronic device of claim 1, further comprising a battery configured to provide power to the integrated circuit and the first coil.

9. The electronic device of claim 1, wherein the integrated circuit comprises a printed integrated circuit.

10. The electronic device of claim 1, wherein the integrated circuit comprises a closed state detector and an open state detector.

11. The electronic device of claim 10, wherein each of the closed state and open state detectors comprises an amplifier configured to amplify an output from a corresponding one of the closed state and open state detectors, an envelope detector configured to determine a maximum value of an output from the corresponding amplifier, and a latch coupled directly or indirectly to an output of the envelope detector and configured to store the maximum value of the output from the corresponding amplifier.

12. An article, package or container, comprising:

- a) first and second parts with an interface therebetween, wherein one of the first and second parts is separable or movable with respect to the other; and
- b) the electronic device of claim 1, wherein the first substrate is or is on one of the first and second parts of the article, package or container, and the second substrate is or is on the other one of the first and second parts of the article, package or container.

13. The article, package or container of claim 12, wherein the package or container is considered open when the first and second coils have the second coupling, and the package or container is considered closed or sealed when the first and second coils have the first coupling.

14. The article, package or container of claim 12, wherein the third coil is closer to the first coil than to the second coil when the container or package is closed or sealed, and when the container or product packaging is open or unsealed, the third coil is (i) absent or (ii) closer to the second coil than when the container or package is closed or sealed.

15. A method of detecting a continuity state of an article, package or container, comprising:

- a) placing first and second coils on a first part of the article, package or container, the first coil having an integrated circuit electrically connected thereto; and
- b) placing a third coil on a second part of the article, package container, wherein one of the first and second parts of the article, container or package is removable or movable with respect to the other one of the first and second parts of the container or product packaging;
- c) using the first, second and third coils, sensing the continuity state of the article, package or container, wherein the first and second coils have a first coupling when the article, package or container is closed or

sealed, and a second, different coupling when the article, package or container is open or unsealed.

16. The method of claim **15**, wherein the article, package or container is considered open or unsealed when the first and second coils have the second coupling, and the article, package or container is considered closed or sealed when the first and second coils have the first coupling.

17. The method of claim **16**, wherein the third coil is closer to the first coil than to the second coil when the article, container or package is closed or sealed, and when the article, container or product packaging is open or unsealed, the third coil is (i) absent or (ii) closer to the second coil than when the article, container or package is closed or sealed.

18. The method of claim **15**, wherein the first, second and third coils form a continuity sensor, the continuity sensor senses or determines the continuity state of the article, container or package, and the first coupling corresponds to a closed or sealed continuity state, and the second coupling corresponds to an open or unsealed continuity state.

19. The method of claim **15**, further comprising providing power to an integrated circuit configured to transmit signals on the first coil using a battery.

20. The method of claim **19**, wherein the integrated circuit comprises a printed integrated circuit.

* * * * *