



US 20170175353A1

(19) **United States**

(12) **Patent Application Publication**
Lipsker et al.

(10) **Pub. No.: US 2017/0175353 A1**

(43) **Pub. Date: Jun. 22, 2017**

(54) **GROUND ANCHOR SYSTEM AND METHOD**

(52) **U.S. Cl.**

(71) Applicant: **LIPSKER & CO. ENGINEERING SERVICES (1975) LTD.**, Kadima (IL)

CPC **E02D 5/80** (2013.01); **E02D 5/808** (2013.01); **E02D 2220/00** (2013.01); **E02D 2250/0007** (2013.01); **E02D 2300/002** (2013.01); **E02D 2600/30** (2013.01); **E02D 2200/1628** (2013.01); **E02D 2250/0046** (2013.01)

(72) Inventors: **Itzhak Lipsker**, Ramat Hasharon (IL);
Yoram Lipsker, Ramat Hasharon (IL);
Boris Goldshlak, Bat Yam (IL)

(21) Appl. No.: **15/449,118**

(57) **ABSTRACT**

(22) Filed: **Mar. 3, 2017**

Related U.S. Application Data

(63) Continuation of application No. 14/774,096, filed on Sep. 9, 2015, now Pat. No. 9,617,703, filed as application No. PCT/IL2014/050304 on Mar. 20, 2014.

(60) Provisional application No. 61/803,548, filed on Mar. 20, 2013.

Publication Classification

(51) **Int. Cl.**
E02D 5/80 (2006.01)

A ground anchor system configured for introducing into a borehole, and comprising a plurality of straps each having a length dimension extending along a central longitudinal axis of the ground anchor system. Each of said straps has a width dimension taken along a major axis and a thickness dimension taken along a minor axis. The major axis and the minor axis are disposed at a transverse plane of the ground anchor system and intersect at a middle point. The middle point of each of said straps is intersected by an imaginary line extending through the longitudinal axis at the transverse plane. The imaginary line forms an angle smaller than 90° with the major axis of the respective strap.

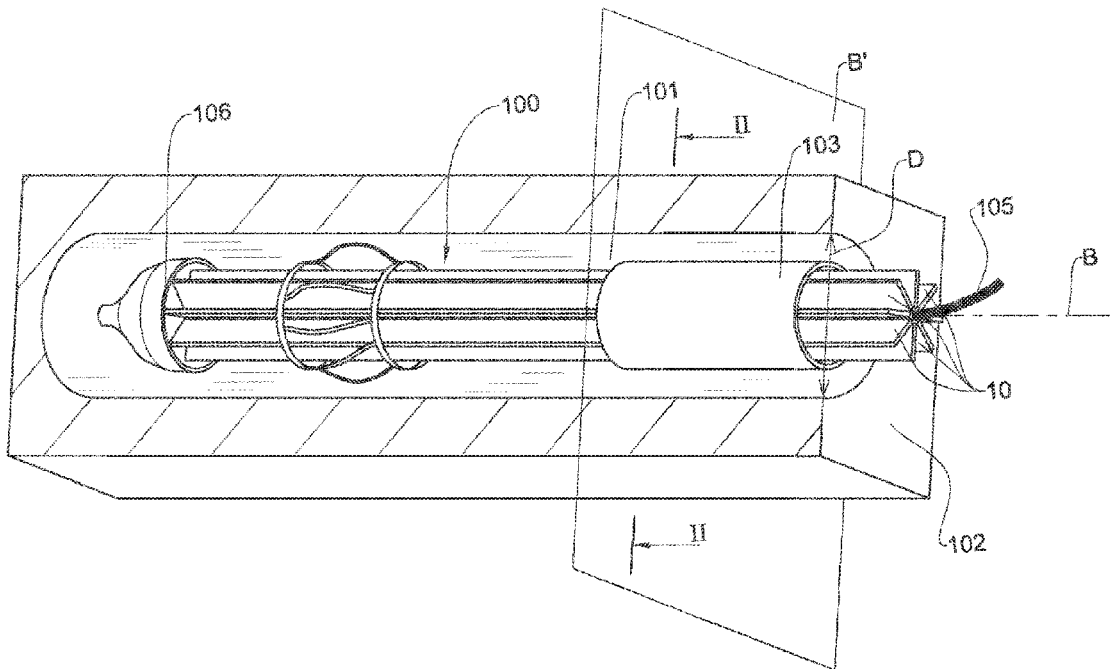

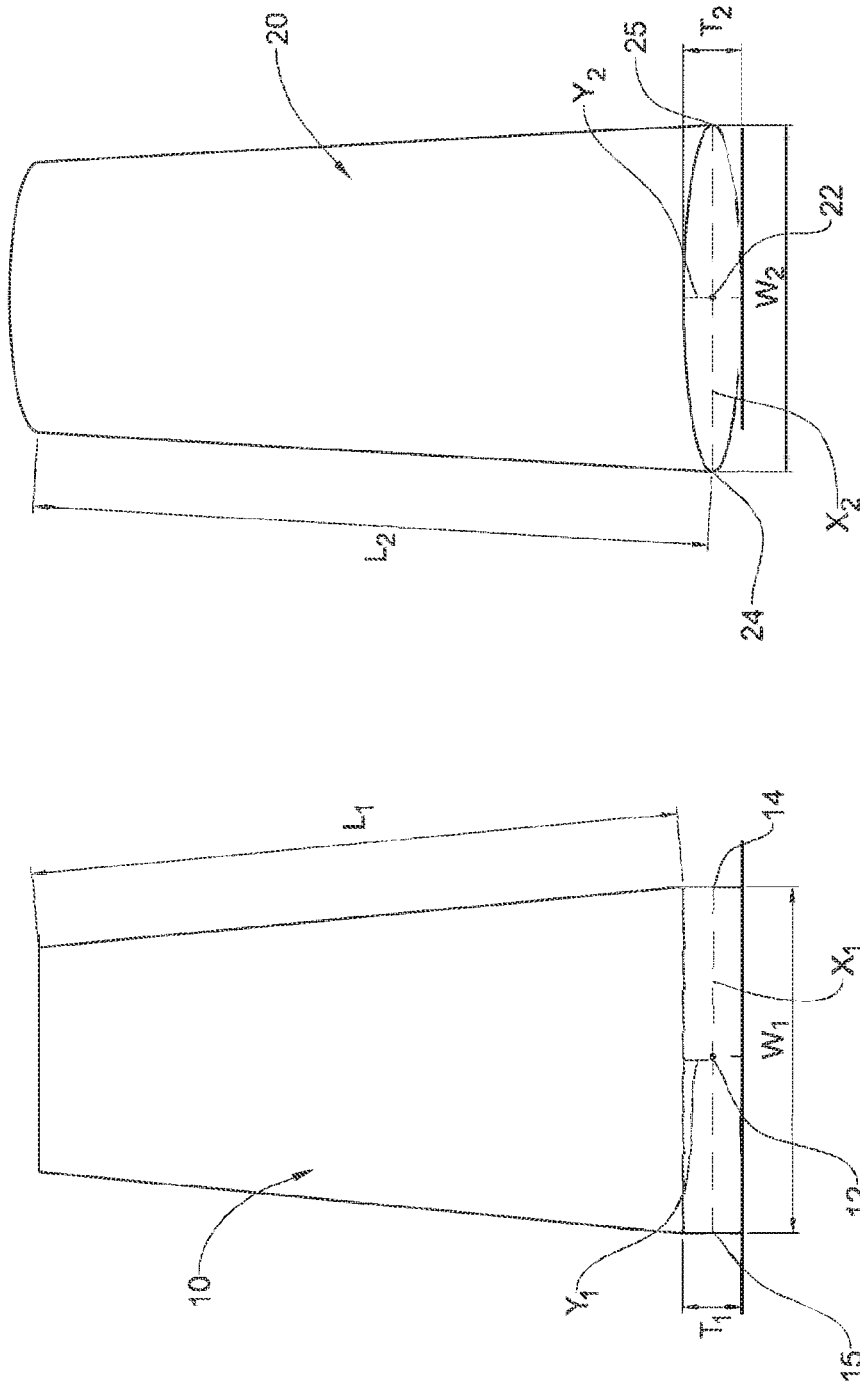

Fig. 1B
(PRIOR ART)

Fig. 1A
(PRIOR ART)

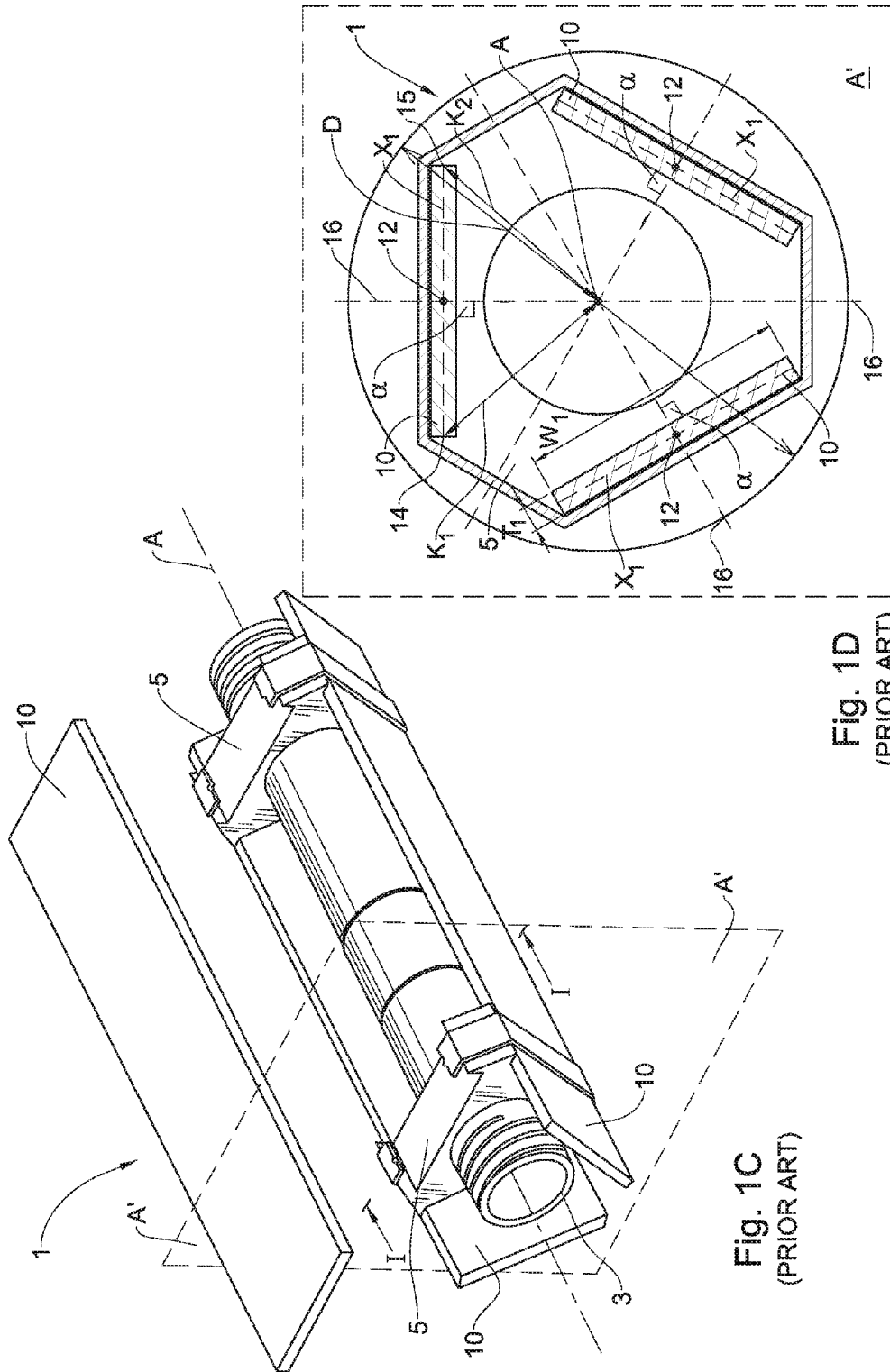

Fig. 1C
(PRIOR ART)

Fig. 1D
(PRIOR ART)

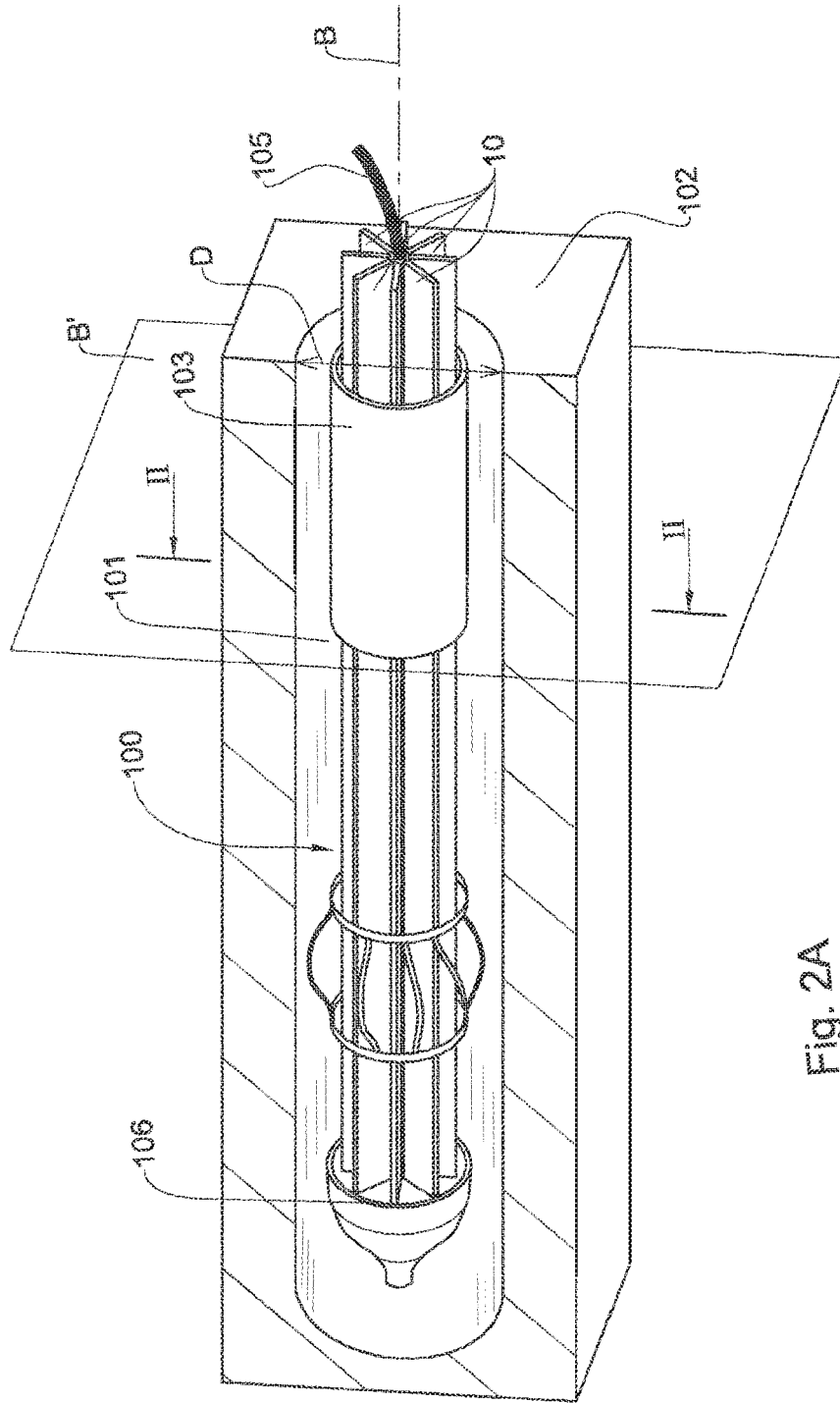

Fig. 2A

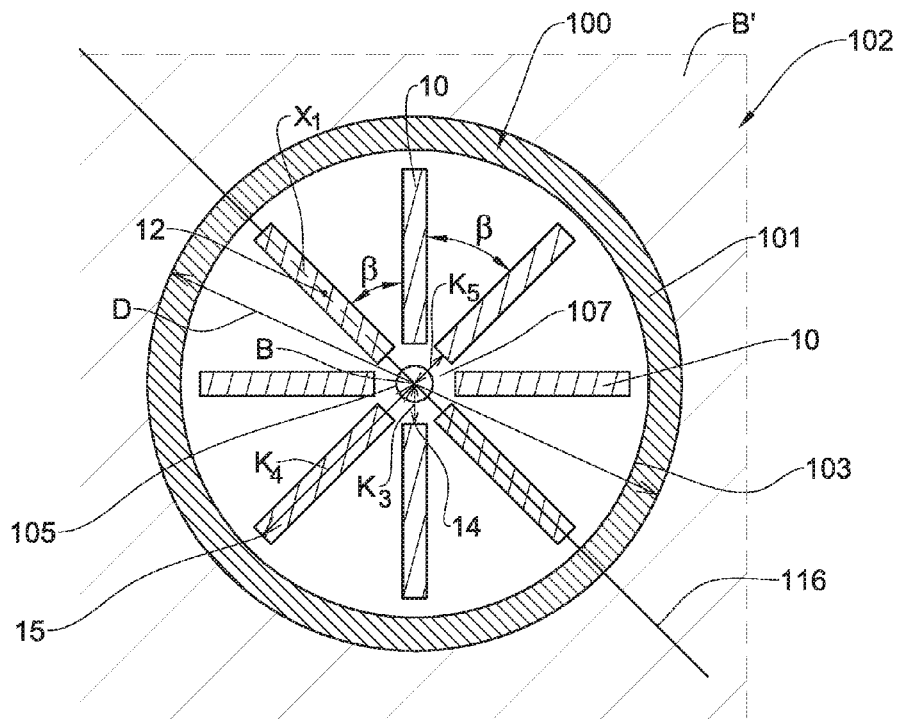

Fig. 2B

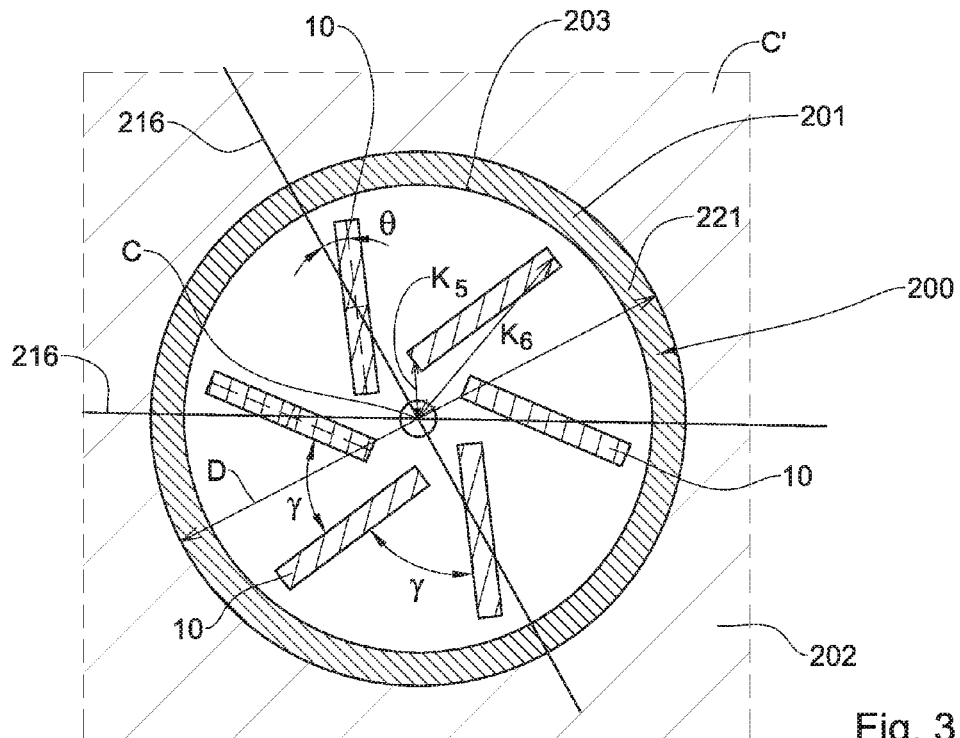

Fig. 3

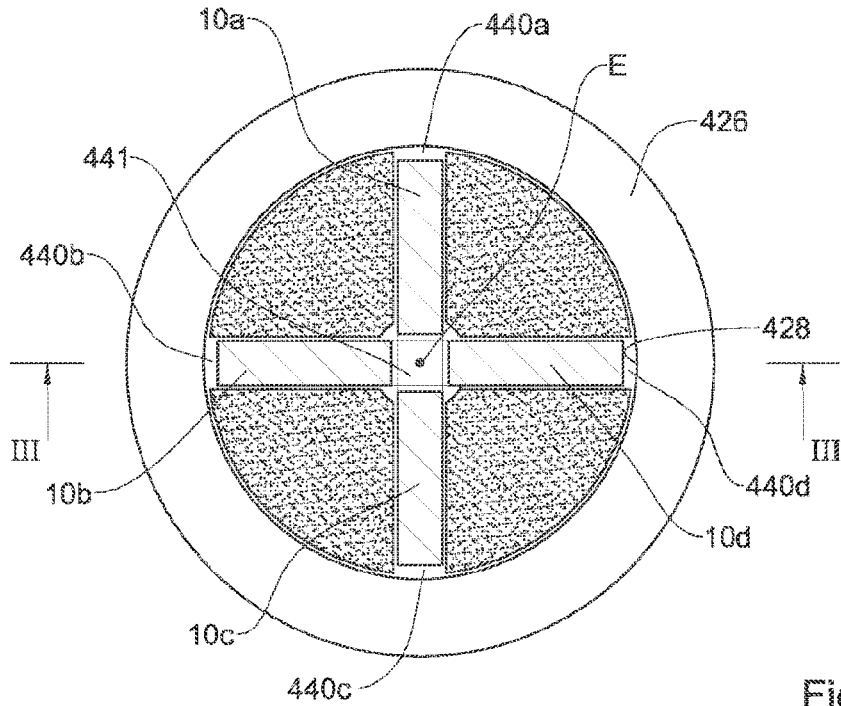

Fig. 4A

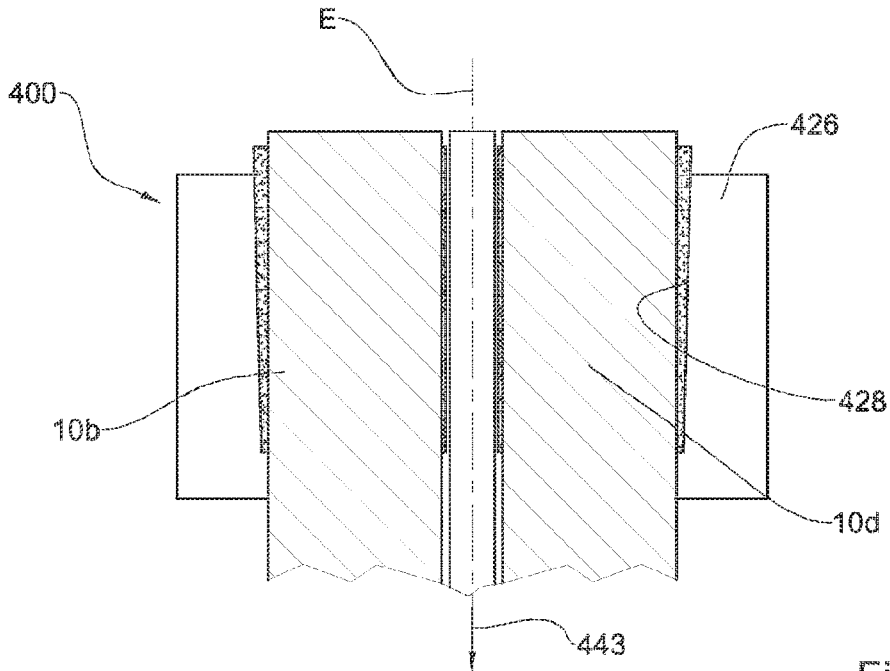

Fig. 4B

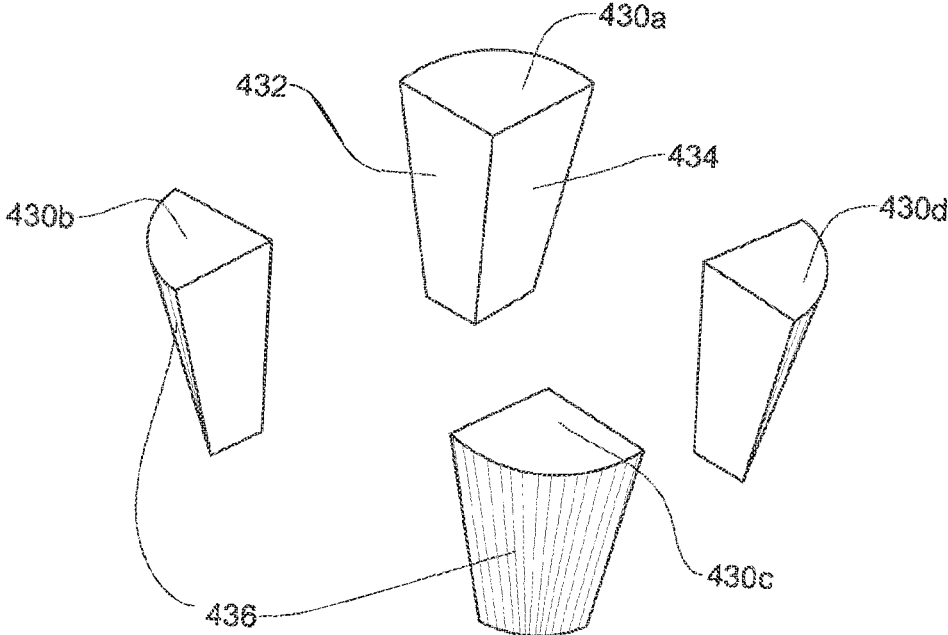

Fig. 5

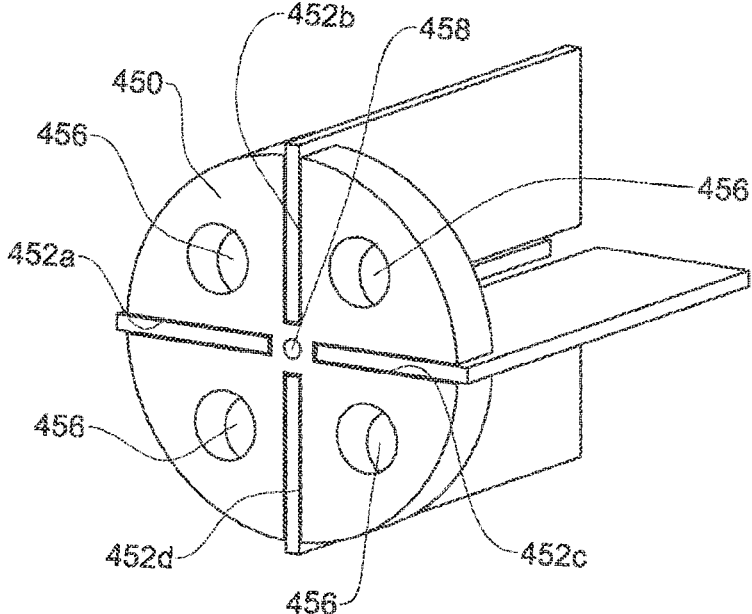

Fig. 6

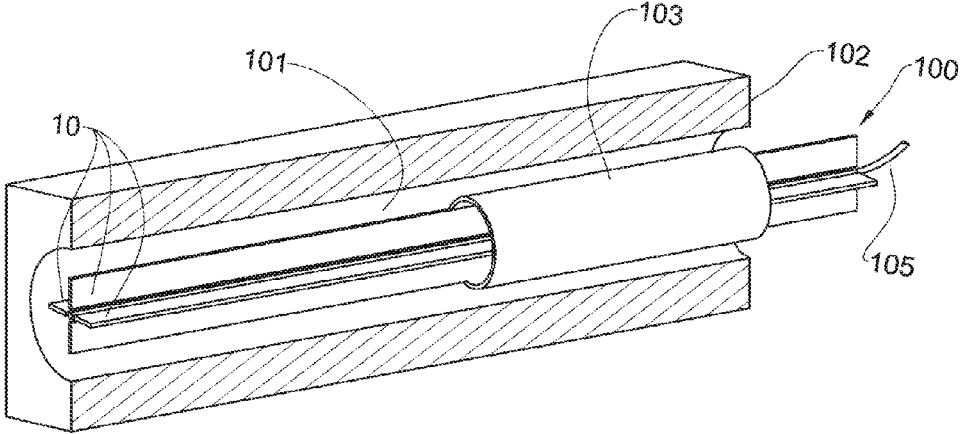

Fig. 7A

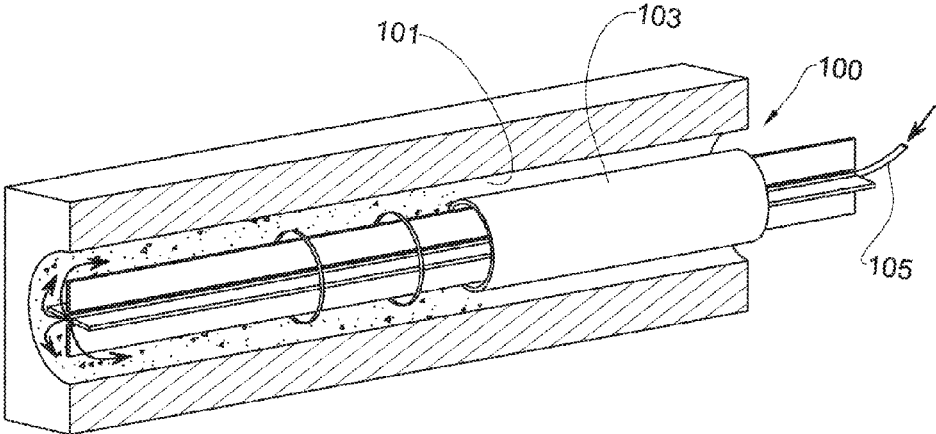

Fig. 7B

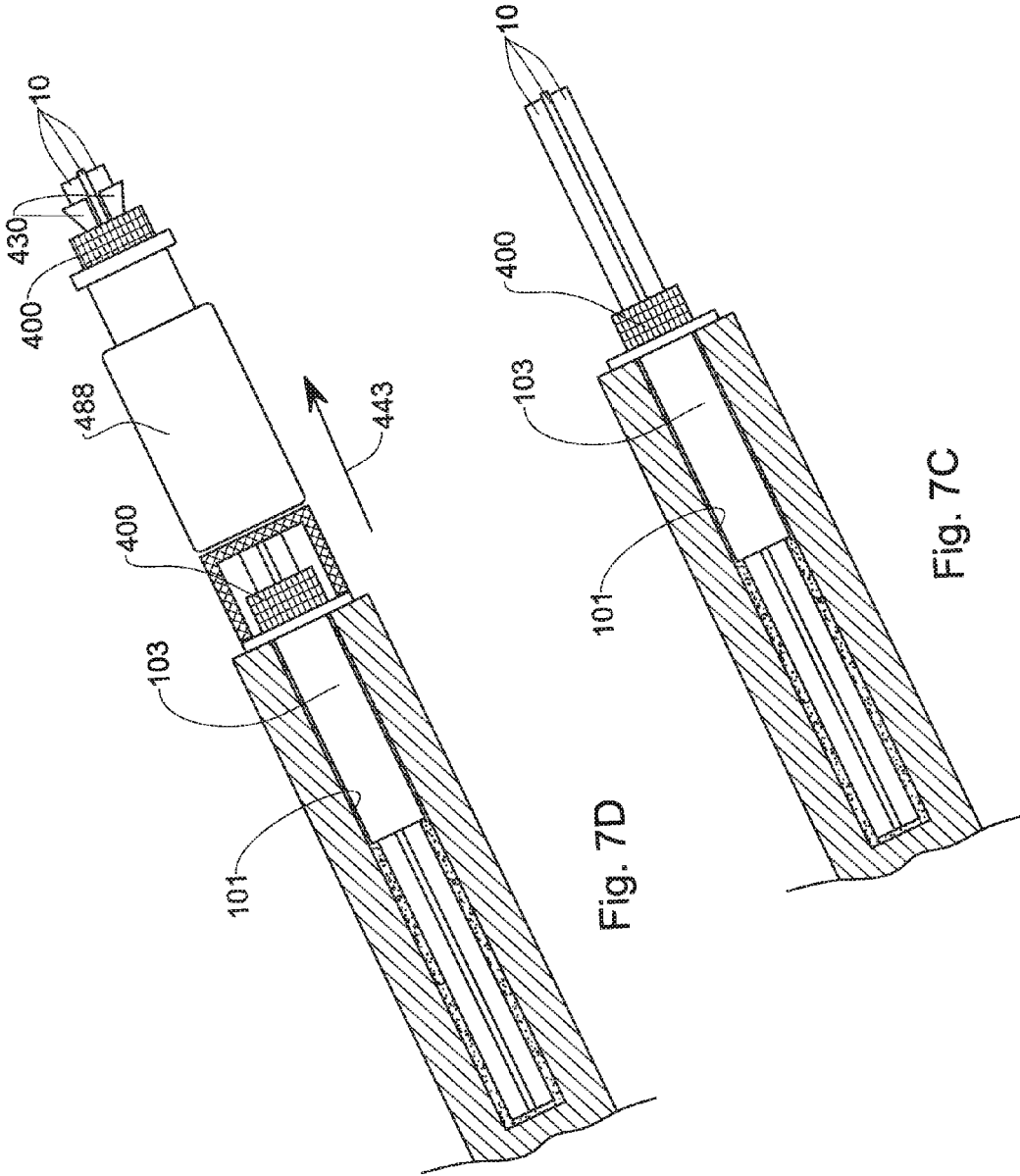

Fig. 7D

Fig. 7C

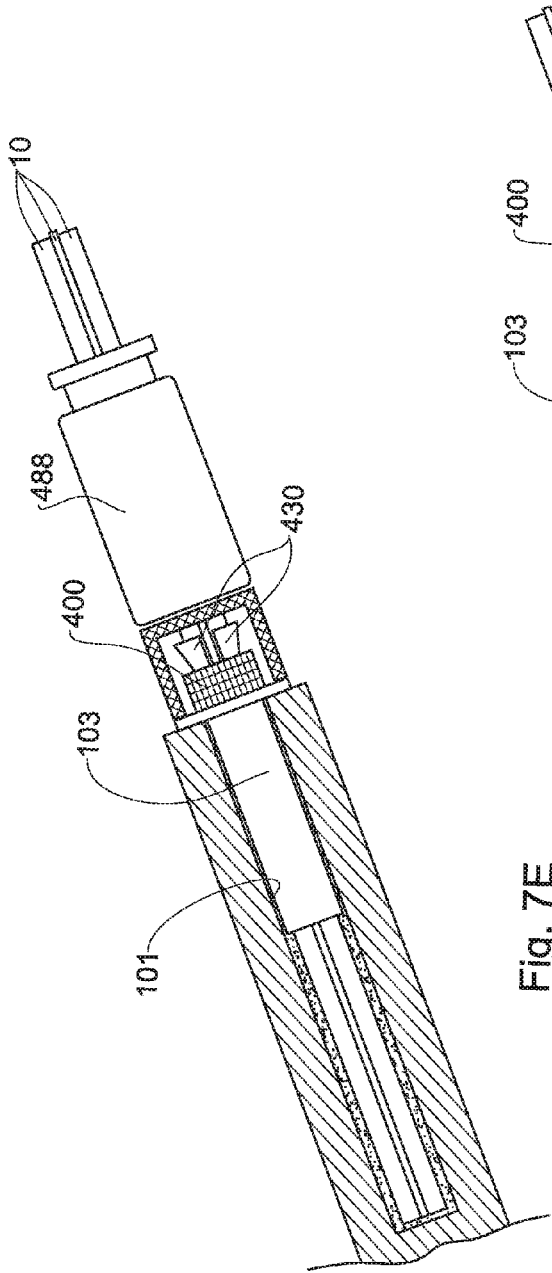

Fig. 7E

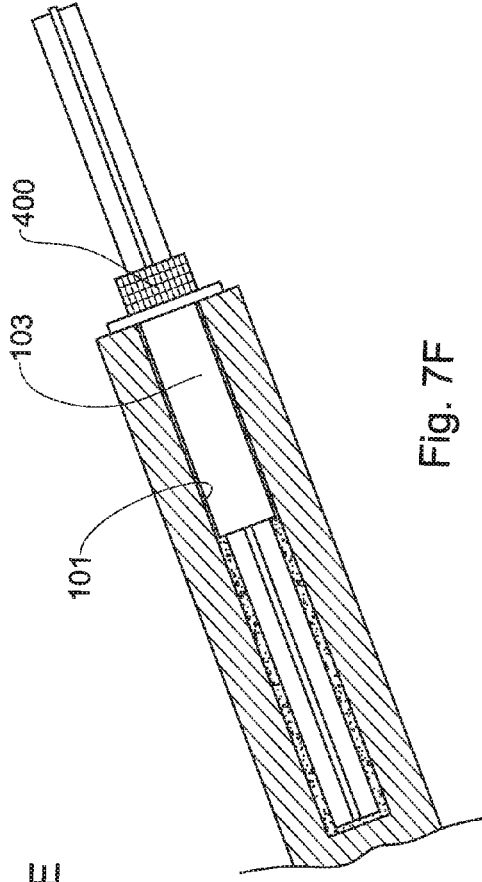

Fig. 7F

GROUND ANCHOR SYSTEM AND METHOD

TECHNOLOGICAL FIELD

[0001] The presently disclosed subject matter is in the field of ground anchoring systems and methods, and more particularly in the field of ground anchoring systems using straps.

BACKGROUND

[0002] A ground anchor system is designed to support a structure (e.g., ground) and is typically used in geotechnical applications. Ground anchor systems consisting of tendons (e.g., cables or rods) connected to a bearing plate are often used for the stabilization of steep slopes or slopes consisting of softer soils, as well as the enhancement of embankment or foundation soil capacity, or to prevent excessive erosion and landslides. Ground anchor systems can hold the walls and posts of outdoor structures to the ground without a foundation or concrete-filled post holes. The strength of the ground anchor's grip is largely determined by the consistency of the site's soil.

[0003] Ground anchor systems can be used in either temporary or permanent applications. Typical use for ground anchor systems includes supporting retaining walls.

[0004] Although most typically made of metallic materials, the tendons of ground anchor systems can be made of fiber-reinforced polymer (FRP), and can have a flat and an elongated shape. FRP is a composite material made of a polymer matrix reinforced with fibers. The fibers are usually glass, carbon, basalt or aramid, although other fibers such as paper or wood or asbestos are sometimes used.

[0005] In particular, it is appreciated that the tendons of ground anchor systems can be made of carbon-fiber-reinforced polymer, carbon-fiber-reinforced plastic or carbon-fiber-reinforced thermoplastic (CFRP, CRP, CI-RTP or often simply carbon fiber, or even carbon), which are extremely strong and light fiber-reinforced polymers which contain carbon fibers.

[0006] CFRP straps are characterized by light weight, corrosion resistant, and can be easily trimmed or cut if required. Due to these characteristics, CFRP are highly suitable for offshore environments and crowded construction areas.

[0007] An example for a ground anchor system can be found in EP 726383, which discloses a device for reinforcement, consolidation and stabilization of the ground, particularly for preventing landslides or deformation of the working face in tunnels or trenches, comprising an injection tube, advantageously with valves, to be inserted in a respective borehole in the ground, around which tube are arranged a plurality of strong reinforcing elements, mounted by means of centering spacers and held together by external retaining elements. According to a particular example disclosed in EP 726383, the tendons are made of glass fiber bars, composed by parallel and continuous glass fibers embedded in a polymer matrix. The use of this material has recently become wide in the field of geotechnical and civil engineering, due to its characteristics. These characteristics include, for example, high tensile strength (twice that of standard steel), corrosion resistance, lightweight, thermal insulation, magnetic insulation and electric insulation.

GENERAL DESCRIPTION

[0008] According to a first aspect of the present subject matter, there is provided a ground anchor system configured for introducing into a borehole, and comprising a plurality of straps each having a length dimension extending along a central longitudinal axis of the ground anchor system, each of said straps having a width dimension taken along a major axis and a thickness dimension taken along a minor axis, said major axis and said minor axis being disposed at a transverse plane of the ground anchor system and intersect at a middle point; wherein said middle point of each of said straps being intersected by an imaginary line extending through the longitudinal axis at said transverse plane, said imaginary line forms an angle smaller than 90° with the major axis of the respective strap.

[0009] The term 'strap' refers to a substantially narrow usually flat elongated tendon or strip, the length of which can be increased upon axial tensioning. The straps have a cross-section area having a geometrical shape which can be symmetric, such as: a rectangular shape, a square shape, an oval shape or an elliptical shape.

[0010] According to a second aspect of the presently disclosed subject matter, there is provided a ground anchor system configured for introducing into a borehole, and comprising a plurality of straps each having a length dimension extending along a central longitudinal axis of the ground anchor system, each of said straps having a width dimension and a thickness dimension smaller than said width dimension, said width dimension and said thickness dimension being taken at a transverse plane of the ground anchor system; said width dimension being defined between an innermost edge of a strap and an outermost edge thereof, and the innermost edge of said straps being disposed closer to the longitudinal axis than the outermost edge.

[0011] The term 'edge' refers hereinafter to an extremity point of a cross section of the strap disposed on a major axis thereof.

[0012] According to a third aspect of the present subject matter there is provided a method for assembling a ground anchor system, comprising:

[0013] (a) providing a plurality of straps each having a length dimension, a width dimension taken along a major axis and a thickness dimension taken along a minor axis smaller than said width dimension, said major axis and said minor axis being taken at a transverse plane of the ground anchor system and intersect at a middle point; and

[0014] (b) disposing said straps along a central longitudinal axis of the ground anchor system so that said length dimension extending along the longitudinal axis and in such a manner that the middle point of each strap being intersected by an imaginary line extending through the longitudinal axis at said transverse plane, said imaginary line forms an angle smaller than 90° with the major axis of the respective strap.

[0015] According to a fourth aspect of the present subject matter there is provided a method for assembling a ground anchor system, comprising:

[0016] (a) providing a plurality of straps each having a length dimension, a width dimension and a thickness dimension smaller than said width dimension, said width dimension and said thickness dimension being taken at a transverse plane of the ground anchor system, the width dimension being defined between an innermost edge of a strap and an outermost edge thereof; and

[0017] (b) disposing said straps along a central longitudinal axis of the ground anchor system so that said length dimension extending along the longitudinal axis and in such a manner that the innermost edge of said straps is disposed closer to the longitudinal axis than the outermost edge.

[0018] The arrangement of the straps according to the above aspects, allows increasing the number of straps to be accommodated within a borehole with a given diameter, such as: an arrangement according to which each of the straps is disposed so that its major axis forms an angle of 90° with its respective imaginary line; or an arrangement according to which the innermost edge and the outermost edge of the straps are equally spaced from the longitudinal axis. The increase in the number of straps to be accommodated within a borehole with a given diameter allows increasing the tensile strength which the entire ground anchor system is able to withstand in the given borehole.

[0019] According to a fifth aspect of the present subject matter there is provided a pre-stressing system for use in conjunction with a ground anchor system, according to the above first and second aspects.

[0020] The pre-stressing system is a so-called wedging device comprising a wedging-ring configured with an cylindrical bore tapering along a longitudinal axis thereof, and a plurality of sectored wedges, each configured with two side walls and an arched wall, wherein the side walls extend substantially parallel to a longitudinal axis and the arched wall axially tapers substantially equal to that of the tapering cylindrical bore, and wherein when the sectored wedges are disposed within the wedging-ring a wedging gap extends between adjoining side walls of two neighboring sectored wedges, said wedging-gap configured for receiving its respective strap of said straps.

[0021] The pre-stressing system is configured for use with an axial tensioning mechanism, configured for applying axial, tensioning force on the straps, so as to tighten the clamping grip of the sectored wedges over the surface of the straps. According to a particular configuration, the straps of the ground anchor system are axially stressed using a single stressing mechanism (e.g. a hydraulic jack).

[0022] According to a sixth aspect of the present subject matter there is provided a method for applying a ground anchoring system into a borehole, the method comprising the following steps:

[0023] a) providing a ground anchor system configured for introducing into a borehole, and comprising a plurality of straps each having a length dimension extending along a central longitudinal axis of the ground anchor system, each of said straps having a width dimension taken along a major axis and a thickness dimension taken along a minor axis, said major axis and said minor axis being disposed at a transverse plane of the ground anchor system and intersect at a middle point; wherein said middle point of each of said straps being intersected by an imaginary line extending through the longitudinal axis at said transverse plane, said imaginary line forms an angle smaller than 90° with the major axis of the respective strap;

[0024] b) introducing the ground anchor system into the borehole in the ground, such that free ends of the straps extend from a surface of the ground;

[0025] c) applying a grouting agent into the borehole and allowing the grouting agent to cure, thereby fixing the ground anchor system to the borehole;

[0026] d) mounting a pre-stressing system over said free ends of the straps;

[0027] e) axially stressing the straps; and

[0028] f) disassembling the pre-stressing system from the straps while preserving them in a stressed position.

[0029] Any one or more of the features, designs and configurations below can be incorporated in any one or more of the aspects of the presently disclosed subject matter, independently or in combinations thereof.

[0030] The straps can be equally spaced from the longitudinal axis.

[0031] The straps can be disposed in a star polygon fashion, such as: a Y-like shape in case of three straps, a + -like shape in case of four straps, a ☆ -like shape in case of five straps.

[0032] The straps can be disposed symmetrically with respect to the longitudinal axis.

[0033] The straps can be disposed substantially equally angularly with respect to each other.

[0034] The cross sectional area of the straps at the transverse plane can have a rectangular shape.

[0035] The straps can be made of a composite material made of a polymer matrix reinforced with fibers, i.e., a fiber-reinforced polymer (FRP). The fibers can be made of glass, carbon, basalt or aramid, although other fibers such as paper or wood or asbestos are sometimes used. Alternatively, the straps can be made metallic materials.

[0036] The straps can be of carbon-fiber-reinforced polymer, carbon-fiber-reinforced plastic or carbon-fiber-reinforced thermoplastic (CFRP, CRP, CFRTP or often simply carbon fiber, or even carbon), which are extremely strong and light fiber-reinforced polymers which contain carbon fibers.

[0037] The straps can also be made of glass fiber bars, composed by parallel and continuous glass fibers embedded in a polymer matrix.

[0038] The width dimension can be smaller than a radius of an inscribed circle of the borehole in which the system is introduced.

[0039] The ground anchor system can comprise at least one grouting tube configured for applying a grouting agent into the borehole, said grouting tube extending along the longitudinal axis.

[0040] According to the first and the third aspects, the width dimension can be defined between an innermost edge of a strap and an outermost edge thereof, and the innermost edge of said straps can be disposed closer to the longitudinal axis than the outermost edge.

[0041] According to the second and the fourth aspects, the width dimension taken along a major axis and the thickness dimension taken along a minor axis, said major axis and said minor axis being disposed at a transverse plane of the ground anchor system and intersect at a middle point; wherein said middle point of each of said straps being intersected by an imaginary line extending through the longitudinal axis at said transverse plane, said imaginary line forms an angle smaller than 90° with the major axis of the respective strap

[0042] The width dimension of the straps can coextend with said imaginary lines.

[0043] The width dimension can be smaller than a radius of an inscribed circle of the borehole.

[0044] The innermost edges of the straps can define a central gap therebetween, and the longitudinal axis can extend substantially coaxially with the central gap.

[0045] The grouting tube can be disposed along the central gap.

[0046] The ground anchor system can comprise one or more spacer-discs configured for retaining the straps at their orientation.

[0047] The spacer-discs can comprise at least one central grouting aperture configured for allowing passage of the grouting tube therethrough.

[0048] The ground anchor system can comprise at least one anchor sleeve configured for accommodating said straps therein.

[0049] The method of the third and the fourth aspects can comprise a step of disposing the straps at an equal space from the longitudinal axis.

[0050] The method of the third and the fourth aspects can further comprise a step of disposing the straps in a star polygon fashion.

[0051] The method of the third and the fourth aspects can further comprise a step of disposing the straps symmetrically with respect to the longitudinal axis.

[0052] The method of the third and the fourth aspects can further comprise a step of disposing the straps substantially equally angularly with respect to each other.

[0053] The straps can be disposed at radial orientations, e.g., extending along a radius of the wedging device.

[0054] The sectored wedges of the wedging device can be made of hard material, such as metal.

[0055] At least portions of surfaces of the side walls of the sectored wedges can be configured with a friction increasing arrangement, such as roughening, knurling, applying a friction-increasing substance, etc.

[0056] The wedging device can accommodate lesser straps than the number of wedging gaps within the wedging device.

[0057] A flat dummy insert can be introduced into one or more wedging-gaps not occupied by a flat tendon, so as to retain respective radial positioning of the sectored wedges.

[0058] A central gap can extend between innermost edges of the flat tendons, said central gap extending substantially coaxially between the sectored wedges within the wedging-ring, i.e. between the vertexes of the sectored wedges.

BRIEF DESCRIPTION OF THE DRAWINGS

[0059] In order to better understand the subject matter that is disclosed herein and to exemplify how it may be carried out in practice, embodiments will now be described, by way of non-limiting example only, with reference to the accompanying drawings, in which:

[0060] FIG. 1A is a perspective view of a strap having a cross section with a rectangular shape, configured for use in conjunction with a ground anchor system according to the prior art;

[0061] FIG. 1B is a perspective view of a strap having a cross section with an oval shape, configured for use in conjunction with a ground anchor system according to the prior art;

[0062] FIG. 1C is an isometric view of a ground anchor system known in the art in which one of the straps is disconnected from the ground anchor system for illustration purposes;

[0063] FIG. 1D is a cross sectional view taken along line I-I in FIG. 1C, with the upper strap connected to the ground anchor system;

[0064] FIG. 2A is a perspective view of a ground anchor system according to one example of the presently disclosed subject matter;

[0065] FIG. 2B is a cross sectional view, taken along line II-II in FIG. 2A;

[0066] FIG. 3 is a cross sectional view of a ground anchor system according to another example of the presently disclosed subject matter;

[0067] FIG. 4A is a front view of a wedging device according to an aspect of the present disclosure, the wedging device configured with four straps;

[0068] FIG. 4B is a sectioned planer view taken along line in FIG. 4A;

[0069] FIG. 5 is an exploded perspective view of the sectored wedges of the wedging device of FIGS. 4A and 4B;

[0070] FIG. 6 is a perspective view of a spacer-disc used in conjunction with the presently disclosed subject matter;

[0071] FIGS. 7A to 7F illustrate sequential steps of a method for applying a ground anchoring system according to the present disclosure;

DETAILED DESCRIPTION OF EMBODIMENTS

[0072] Attention is first directed to FIGS. 1A and 1B of the drawings, illustrating a perspective view of two example of known in the art straps, generally designated **10** and **20**, configured for use in conjunction with a ground anchor system. The straps **10** and **20** are flat tendons made of a polymeric material. In particular, the straps **10** and **20** are made of Carbon Fiber Reinforced Polymers (CFRPs), belonging to a group of Fiber Reinforced Polymers (FRPs) and composites thereof. The CFRPs are used in the field of ground anchoring since they are able to bear high axial loads, to resist to corrosion (as opposed to metal tendons) and to be easily trimmed or cut when required.

[0073] As seen in the drawings, the straps **10** and **20** are examples of flat tendons having a different cross-sectional shape, as detailed below.

[0074] As seen in FIG. 1A, the strap **10** has a length dimension L_1 , a width dimension W_1 and a thickness dimension T_1 , so that $L_1 \gg W_1 > T_1$. The strap **10** is substantially straight along its length dimension L_1 . The width dimension W_1 and thickness dimension T_1 refer to dimensions of a cross section of the strap **10**, taken at a plane that is transverse to an axis along which the length dimension L_1 is taken. The cross section of the strap **10** is characterized by a major axis X_1 and a minor axis Y_1 , being perpendicular to each other. The cross section of the strap **10** has a rectangular shape. The width dimension W_1 is taken along the major axis X_1 between an innermost edge **14** and an outermost edge **15** and the thickness dimension T_1 is taken along the minor axis Y_1 . The major axis X_1 is centered with respect to the thickness dimension T_1 , and the minor axis Y_1 is centered with respect to the width dimension W_1 . The major and the minor axes X_1 and Y_1 intersect at a middle point **12**.

[0075] As seen in FIG. 1B, the strap **20** that is shown from a perspective view, has a length dimension L_2 , a width dimension W_2 and a thickness dimension T_2 , so that $L_2 \gg W_2 > T_2$. The strap **20** is substantially straight along its length dimension L_2 . The width dimension W_2 and thickness dimension T_2 refer to dimensions of a cross section of the strap **20**, taken at a plane that is transverse to an axis along which the length dimension L_2 is taken. The cross section of the strap **20** is characterized by a major axis X_2 and a minor axis Y_2 , being perpendicular to each other. The cross section

of the strap **20** has an oval shape. The width dimension W_2 is taken along the major axis X_2 between an innermost edge **24** and an outermost edge **25** and the thickness dimension T_2 is taken along the minor axis Y_2 . The major axis X_2 is centered with respect to the thickness dimension T_2 , and the minor axis Y_2 is centered with respect to the width dimension W_2 . The major and the minor axes X_2 and Y_2 intersect at a middle point **22**.

[0076] Attention is now directed to FIGS. **1C** and **1D** of the drawings, illustrating a known in the art ground anchor system **1** having a longitudinal axis A and a transverse plane A' , being perpendicular thereto. The ground anchor system **1** comprises: three of the straps **10**, a central tube **3** and spacers **5**. The straps **10** are positioned in the ground anchor system **1** in accordance with a specific orientation with respect to each other, as detailed below.

[0077] The three straps **10** extend along the longitudinal axis A and are radially disposed with respect thereto. The straps **10** are mounted on the central tube **3** by the spacers **5**.

[0078] As can be seen in FIG. **1D**, each one of the straps **10** is disposed in such a manner that its middle point **12** is intersected by an imaginary line **16**, extending through the longitudinal axis A at the transverse plane A' . Each one of the imaginary lines **16** forms with the major axis X_1 of the respective strap **10** an angle α that is equal to 90° .

[0079] It is further seen in FIG. **1D** that a distance K_1 , extending between the innermost edge **14** of the strap **10** and the longitudinal axis A is equal to the distance K_2 , extending between the outermost edge **15** of the strap **10** and the longitudinal axis A .

[0080] Reference is now made to the ground anchor system **1** of FIG. **1D** in order to explain its limitations with respect to a particular example of straps and borehole having particular dimensions. As can be seen in FIG. **1D**, the ground anchor system **1** is configured to be installed within a borehole having a diameter D which is equal to 110 mm. On the other hand, the width dimension W_1 of the strap **10** is equal 40 mm and the thickness dimension T_1 is equal to 9 mm. Each of the three straps **10** has a tensile strength of 360 KN. This means that the ground anchor system **1** is configured to withstand a tensile strength of 1,080 KN (3×360 KN). It is well known in the field of ground anchoring that sometimes there is a need to provide a ground anchor system which is able to withstand much higher tensile strength (e.g., 2,000 KN, 3,000 KN) for a given borehole (e.g., having a diameter D of 110 mm). In order to provide such a system, it is possible to use straps having other characteristics (e.g., thickness, width, structure, material, etc.), but this can be expensive or even non-feasible. Alternatively, it is possible to increase the number of the straps within the system. However, the arrangement of the straps within the system, such as the arrangement of FIGS. **1C** and **1D**, would limit or even not allow that.

[0081] This problem can be solved by arranging the straps in accordance with a more compact arrangement as provided by the system of the presently disclosed subject matter, and as explained below with respect to particular examples.

[0082] Reference is now made to FIGS. **2A** and **2B**, illustrating an example of a ground anchor system **100** according to the presently disclosed subject matter.

[0083] The ground anchor system **100** is accommodated within a round borehole **101** having a diameter D which is equal to 110 mm. The ground anchor system **100** is

configured with eight of the straps **10**, the length dimension of which extends along a central longitudinal axis B . The longitudinal axis B is perpendicular to a transverse plane B' of the system. The straps **10** are accommodated within a sleeve **103**. As can be seen, free ends of the straps **10** extend from a surface **102** of the ground, while the remaining portions of the straps **10** are fully accommodated within the borehole.

[0084] The ground anchor system **100** comprises a grouting tube **105** extending along the longitudinal axis B . The grouting tube **105** has a distal end that is connected to a distributor **106**. The grouting tube **105** is configured to receive a grouting agent via its proximal end, and to deliver the grouting agent into the borehole **101** via the distributor **106**. The grouting tube **105** is disposed along a central gap **107**, best seen in FIG. **2B**, which is defined by the innermost edges **14** of the straps **10**, and extends substantially coaxially with the longitudinal axis B .

[0085] As aforementioned, one of the alternatives for increasing the tensile strength of a ground anchor system is by increasing the number of the straps within the system. Since the system is configured for introducing into a given borehole with a given diameter D , its external dimensions have to be preserved while straps are added thereto. Increasing the number of straps, without changing the external dimensions of the system can be obtained by the arranging the straps within the system in a different and more compact manner. One example of such an arrangement is shown in FIGS. **2A** and **2B**, and another example, is shown in FIG. **3**, the description of which is provided below.

[0086] Reference is now made to FIG. **2B**, in which the disposition of the straps **10** within the system and their orientation with respect to the longitudinal axis B is shown.

[0087] The straps **10** are radially disposed with respect to the longitudinal axis B and radially extend therefrom. According to the present example, the straps **10** are disposed in a star polygon fashion, and in particular of a star polygon having eight vertices, wherein each one of the straps **10** is associated with its respective vertex of the star polygon. According to other examples, the ground anchor system can be provided with a different number of the straps **10**, which are disposed in a star polygon fashion, i.e.: a Y-like shape in case of three straps, a +-like shape in case of four straps, a ☆-like shape in case of five straps, etc. The straps **10** are equally spaced from the longitudinal axis B so that the innermost edge **14** of each strap is disposed closer to the longitudinal axis B than its outermost edge **15**. According to this arrangement, the innermost edge **14** of each one of the straps **10** is distant from the longitudinal axis B to a distance K_3 and the outermost edge **15** is distant from the longitudinal axis B to a distance K_4 ($K_3 < K_4$). In addition, the straps **10** are disposed symmetrically with respect to the longitudinal axis B , and equally angularly with respect to each other, with an angle β therebetween. In the specific example of eight straps **10**, the angle β is equal to 45° , but can vary depending on the number of straps **10**, according to the formula $360/n$, for a system having n of the straps **10**.

[0088] As can further be seen in FIG. **2B**, each one of the middle points **12** of the straps **10** is intersected by an imaginary line **116** that extends through the longitudinal axis B . The imaginary lines **116** extend at the plane B' and are provided for explaining the angular orientation of the straps **10** within the ground anchor system **100**.

[0089] The arrangement of the straps **10** is such that the imaginary lines **116** coextend with their major axis X_1 so that the angle of 0° is formed therebetween.

[0090] The arrangement of the straps according to the example of FIGS. 2A and 2B provided a ground anchor system with eight of the straps **10**. Since each one of the straps **10** has a tensile strength of 360 KN, the entire system can withstand a tensile strength of 2,880 KN (8×360 KN). While the ground anchor system **100** is able to withstand such a tensile strength, it still can be mounted within a borehole having a diameter D of 110 mm.

[0091] Referring now to FIG. 3, which is a cross section of another example of a ground anchor system according to the presently disclosed subject matter, generally designated **200**. A perspective view of the ground anchor system **200** is not presented in the drawings. The ground anchor system **200** includes an arrangement of the straps **10** in accordance with the general concept of the presently disclosed subject matter, as detailed below.

[0092] Similarly to ground anchor system **100**, the ground anchor system **200** is accommodated within a substantially round borehole generally designated **201** and characterized by a diameter D . Furthermore, the ground anchor system **200** has components that are similar to those of the ground anchor system **100**, but has another arrangement of straps therein.

[0093] The ground anchor system **200** is configured with six of the straps **10**, the length dimension of which extends along a central longitudinal axis C . The longitudinal axis C is perpendicular to a transverse plane C' of the system. The straps **10** are accommodated within a sleeve **203**.

[0094] The straps **10** of FIG. 3 are equally spaced from the longitudinal axis C so that the innermost edge **14** of each strap is disposed closer to the longitudinal axis C than its outermost edge **15**. According to this arrangement, the innermost edge **14** of each one of the straps **10** is distant from the longitudinal axis C to a distance K_5 and the outermost edge **15** is distant from the longitudinal axis C to a distance K_6 ($K_5 < K_6$). In addition, the straps **10** are disposed symmetrically with respect to the longitudinal axis C , and equally angularly with respect to each other, with an angle γ therebetween. In the specific example of six straps **10**, the angle γ is equal to 60° .

[0095] As can further be seen in FIG. 3, each one of the middle points **12** of the straps **10** is intersected by an imaginary line **216** that extends through the longitudinal axis C . The imaginary lines **216** extend at the plane C' and are provided for explaining the angular orientation of the straps **10** within the ground anchor system **200**.

[0096] The arrangement of the straps **10** in FIG. 3 is such that the each one of the imaginary lines **216** forms an acute angle θ , i.e. an angle smaller than 90° .

[0097] It is appreciated that the example of FIG. 3 is a general example of an arrangement of the straps **10**, which allows increasing the number of the straps within the system **10**, while preserving the external dimensions of the system.

[0098] According to example, the angle θ can vary within a spectrum of all acute angles, i.e. can be any angle smaller than 90° , in accordance with the engineering requirements of the system, e.g., the tensile strength of the system.

[0099] The arrangement of the straps according to the example of FIGS. 3 provided a ground anchor system with six of the straps **10**. Since each one of the straps **10** has a tensile strength of 360 KN, the entire system can withstand

a tensile strength of 2,160 KN (6×360 KN). While the ground anchor system **200** is able to withstand such a tensile strength, it still can be mounted within a borehole having a diameter D of 110 mm.

[0100] The ground anchor systems **100** and **200** can be assembled in accordance with a method of the presently disclosed subject matter, which can be performed prior to applying it into the borehole, and can be performed at a construction site or at any other location remote therefrom.

[0101] The method for assembling the ground anchor system **100** includes at least the following steps:

[0102] providing eight of the straps **10**; and

[0103] disposing the straps **10** so that their major axis X_1 coextends with the imaginary line **116** and their innermost edge **114** is distant from the longitudinal axis B to the distance K_3 .

[0104] The method for assembling the ground anchor system **200** includes at least the following steps:

[0105] providing eight of the straps **10**; and

[0106] disposing the straps **10** so that their major axis X_1 coextends with the imaginary line **216** and their innermost edge **214** is distant from the longitudinal axis B to the distance K_5 .

[0107] Referring now to FIGS. 4A and 4B, illustrating a wedging device **400**, configured for use in conjunction with the ground anchor system according to the presently disclosed subject matter. The wedging device **400** comprises a wedging-ring **426** (typically made of steel) configured with a cylindrical bore **428** tapering along a longitudinal axis E thereof. The wedging device **400** further comprises a plurality of sector wedges typically made of steel (four in the illustrated example; designated **430a**, **430b**, **430c** and **430d**; said sector wedges best seen in FIG. 5), each configured with two side walls **432** and **434**, and an arched wall **436**. The arrangement is such that the side walls **432** and **434** extend substantially parallel to the longitudinal axis D and the arched walls **436** axially taper at an extent similar to the tapering cylindrical bore **428**.

[0108] Accordingly, when the sector wedges **430a**, **430b**, **430c** and **430d** are disposed within the wedging-ring **426** four wedging-gaps **440a**, **440b**, **440c** and **440d** extend between adjoining side walls **432** and **434** of two neighboring sector wedges **430a**, **430b**, **430c** and **430d**, respectively. The wedging-gaps **440a**, **440b**, **440c** and **440d** are each configured, as far as size and shape, for receiving a strap **10** radially disposed therein, said straps designated **10a**, **10b**, **10c** and **10d**, respectively.

[0109] As can best be seen in FIG. 4A, the straps **10a**, **10b**, **10c** and **10d** are disposed at a radial orientation, i.e. extending along the radius of the wedging device **400**. Furthermore, the sector wedges **430a**, **430b**, **430c** and **430d**, and likewise the straps, are disposed symmetrically within the wedging device **400**, i.e. are substantially equally angularly disposed therein. As a result of the structure disclosed, a central gap **441** extends between innermost edges of the straps, said central gap **441** extending substantially coaxially along axis E between the sector wedges within the wedging-ring, i.e. between the vertexes of the sector wedges.

[0110] The arrangement is such that axial tensioning the straps designated **10a**, **10b**, **10c** and **10d** in direction of arrow **443** (FIG. 7D) whilst retaining the wedging device **400** or pulling it at a sense opposed to direction of arrow **443**, results in clapping the sector wedges **430a**, **430b**, **430c**

and **430d** about the straps **10a**, **10b**, **10c** and **10d**, so as to prevent their detaching from the wedging device **400**.

[0111] FIG. 6 illustrates a spacer disk **450** used in conjunction with an anchoring system according to the present disclosure. The spacer disk **450** serves on the one hand for retaining the plurality of straps at their respective radially disposed position as discussed hereinabove, along the borehole into which the ground anchor system is introduced as will be hereinafter discussed with reference to FIGS. 7A to 7F, and on the other hand the spacer disk **450** facilitates flow of fluid grouting material therethrough, i.e. so as not to constitute a barrier for flow of the grouting agent throughout the entire depth of the bore of the ground anchor.

[0112] Spacer disk **450** is configured with a plurality (four in the particular example) of radially extending slots **452a**, **452b**, **452c** and **452d**, which when mounted in the ground anchor system (see hereinafter) are disposed substantially in register with the a four wedging-gaps **440a**, **440b**, **440c** and **440d** extending between neighboring sectored wedges **430a**, **430b**, **430c** and **430d**. The spacer disk **450** is further configured with a plurality of openings **456** and a central opening **458** (coinciding with the longitudinal axis E and with the central gap **441**, facilitating flow of fluid grouting material therethrough.

[0113] As can further be seen in FIG. 6, the spacer-disc can have a diameter smaller than that of the circumference defined by the radially remote edges of the radially disposed straps **10a**, **10b**, **10c** and **10d**, such that fluid grouting agent can flow therethrough.

[0114] Turning now to FIGS. 7A to 7F, there are illustrated sequential steps of a method for applying a ground anchor system according to the present disclosure. It is however appreciated that the method is similar to methods performed insofar, with the exception of using ground anchor systems in accordance with the present disclosed subject matter, configured for use with radially disposed straps.

[0115] The method comprising the following steps:

[0116] a) providing a ground anchor system **100**;

[0117] b) introducing the ground anchor system **100** into the borehole **101** in the ground, such that free ends of the straps **100** extend from a surface **102** of the ground (FIG. 7A);

[0118] c) applying a grouting agent into the borehole via the grouting tube **105** and allowing the grouting agent to cure, thereby fixing the ground anchor system **100** to the borehole **101** (FIG. 7B);

[0119] d) disposing a wedging device **400** over the free ends of the straps **10** (FIG. 7C).

[0120] e) mounting a pre-stressing system, e.g. tensioning mechanism such as jack **488**, over said free ends of the straps **100** (FIG. 7D);

[0121] f) axially stressing the straps. In the illustrated example the axial stressing is performed by jack **488** (FIG. 7D);

[0122] g) mounting a second wedging device **400** according to the disclosure behind the tensioning mechanism **488** (FIG. 7D);

[0123] h) axially stressing the ground-anchor system as indicated by arrow **443** (FIG. 7D)

[0124] i) axially fixing the straps **10** by the second wedging device **400**, allowing setting of the first wedging device **400** (FIG. 7E); and

[0125] j) disassembling the pre-stressing system from the straps while preserving them in a stressed position.

1. A ground anchor system configured to be introduced into a borehole, the ground anchor system comprising:

a plurality of straps each having a length dimension extending along a central longitudinal axis of the ground anchor system between a distal end and a proximal end, each of the plurality of straps having a width dimension taken along a major axis and a thickness dimension taken along a minor axis, the major axis and the minor axis being disposed at a transverse plane of the ground anchor system and intersect at a middle point; and

an anchor sleeve configured for enveloping the plurality of straps therein;

wherein each of the plurality of straps includes a middle point intersected by an imaginary line extending through the longitudinal axis at the transverse plane, the imaginary line forms an angle smaller than 90° with the major axis of the respective strap; and

wherein said anchor sleeve has a sleeve length that is shorter than said length dimension of the straps, so that when said anchor sleeve envelopes the straps, said distal end of the plurality of straps is free of said anchor sleeve.

2. The ground anchor system according to claim 1, wherein said distal end of the plurality of straps is configured for directly contacting a grouting agent when being at least partially grouted within the borehole.

3. The ground anchor system according to claim 1, wherein said proximal end of the plurality of straps is free of said anchor sleeve to be axially stressed by a pre-stressing system after being at least partially grouted within the borehole.

4. The ground anchor system according to claim 1, wherein the plurality of straps are substantially equally spaced from the longitudinal axis.

5. The ground anchor system according to claim 1, wherein the plurality of straps are disposed substantially symmetrically with respect to the longitudinal axis.

6. The ground anchor system according to claim 1, wherein the plurality of straps are disposed substantially equally angularly with respect to each other.

7. The ground anchor system according to claim 1, wherein each of the plurality of straps at the transverse plane has a cross-sectional area exhibiting a rectangular shape.

8. The ground anchor system according to claim 1, wherein each of the plurality of straps are made of polymeric material.

9. The ground anchor system according to claim 1, wherein the width dimension is smaller than a radius of an inscribed circle of the borehole in which the ground anchor system is introduced.

10. The ground anchor system according to claim 1, wherein the width dimension is defined between an innermost edge and an outermost edge of each of the plurality of straps, and the innermost edge is disposed closer to the longitudinal axis than the outermost edge.

11. A ground anchor system configured to be introduced into a borehole, the ground anchor system comprising:

a plurality of straps each having a length dimension extending along a central longitudinal axis of the ground anchor system between a distal end and a proximal end, each of the plurality of straps having a width dimension and a thickness dimension smaller than the width dimension, the width dimension and the

thickness dimension being taken at a transverse plane of the ground anchor system; and
an anchor sleeve configured for enveloping the plurality of straps therein;

wherein the width dimension is defined between an innermost edge and an outermost edge of each of the plurality of straps;

wherein the innermost edge of each of the plurality of straps is disposed closer to the longitudinal axis than the outermost edge; and

wherein said anchor sleeve has a sleeve length being shorter than said length dimension of the straps, so that when said anchor sleeve envelopes the straps, said distal end of the straps is free of said anchor sleeve.

12. The ground anchor system according to claim **11**, wherein said distal end of the plurality of straps is configured for directly contacting a grouting agent when being at least partially grouted within the borehole.

13. The ground anchor system according to claim **11**, wherein said proximal end of the plurality of straps is free of said anchor sleeve to be axially stressed by a pre-stressing system after being at least partially grouted within the borehole.

14. The ground anchor system according to claim **11**, wherein the innermost edges of the plurality of straps define a central gap therebetween, and the longitudinal axis extends substantially coaxially with the central gap.

15. The ground anchor system according to claim **11**, wherein a middle point at the width dimension of each of the plurality of straps is intersected by an imaginary line extending through the longitudinal axis at the transverse plane, the imaginary line forms an angle smaller than 90° with the width dimension of the respective strap.

16. The ground anchor system according to claim **11**, wherein the plurality of straps are substantially equally spaced from the longitudinal axis.

17. The ground anchor system according to claim **11**, wherein the plurality of straps are disposed substantially symmetrically with respect to the longitudinal axis.

18. The ground anchor system according to claim **11**, wherein the plurality of straps are disposed substantially equally angularly with respect to each other.

19. The ground anchor system according to claim **11**, wherein each of the plurality of straps at the transverse plane has a cross-sectional area exhibiting a rectangular shape.

* * * * *