



US 20150082765A1

(19) **United States**  
(12) **Patent Application Publication**  
**Wesley et al.**

(10) **Pub. No.: US 2015/0082765 A1**  
(43) **Pub. Date: Mar. 26, 2015**

(54) **CABLE STRANDING APPARATUS  
EMPLOYING A HOLLOW-SHAFT GUIDE  
MEMBER DRIVER**

**Publication Classification**

(71) Applicant: **Corning Optical Communications  
LLC, Hickory, NC (US)**  
(72) Inventors: **Chiasson David Wesley, Edmonton  
(CA); Craig Miller Conrad, Hickory,  
NC (US); Jonathan Edward Moon,  
Greensboro, NC (US); Mark Wade  
Petersen, Winston-Salem, NC (US);  
David Henry Smith, Hickory, NC (US)**

(51) **Int. Cl.**  
**D07B 3/00** (2006.01)  
**D01H 13/00** (2006.01)  
**D07B 7/14** (2006.01)  
(52) **U.S. Cl.**  
CPC **D07B 3/005** (2013.01); **D07B 7/14** (2013.01);  
**D01H 13/00** (2013.01); **D07B 2201/2035**  
(2013.01)  
USPC ..... **57/293; 57/100**

(21) Appl. No.: **14/563,346**

(22) Filed: **Dec. 8, 2014**

**Related U.S. Application Data**

(63) Continuation of application No. 13/442,104, filed on Apr. 9, 2012, now Pat. No. 8,904,743, which is a continuation-in-part of application No. 12/271,104, filed on Nov. 14, 2008, now abandoned, which is a continuation-in-part of application No. 12/571,052, filed on Sep. 30, 2009, now Pat. No. 8,161,721.

(57) **ABSTRACT**

A cable-stranding apparatus includes a stationary guide, a motor, a driven guide, and a controller electrically coupled to the motor. The stationary guide is configured to guide strand elements in a spaced-apart configuration and to pass a core member. The motor is operatively associated with a guide driver. The driven guide is disposed at least partially within the guide driver so as to rotate therewith. The driven guide is configured to receive the strand elements from the stationary guide, individually guide the strand elements received from the stationary guide, and to further pass the core member. The controller is electrically coupled to the motor and configured to control the rotational speed and direction of the motor.

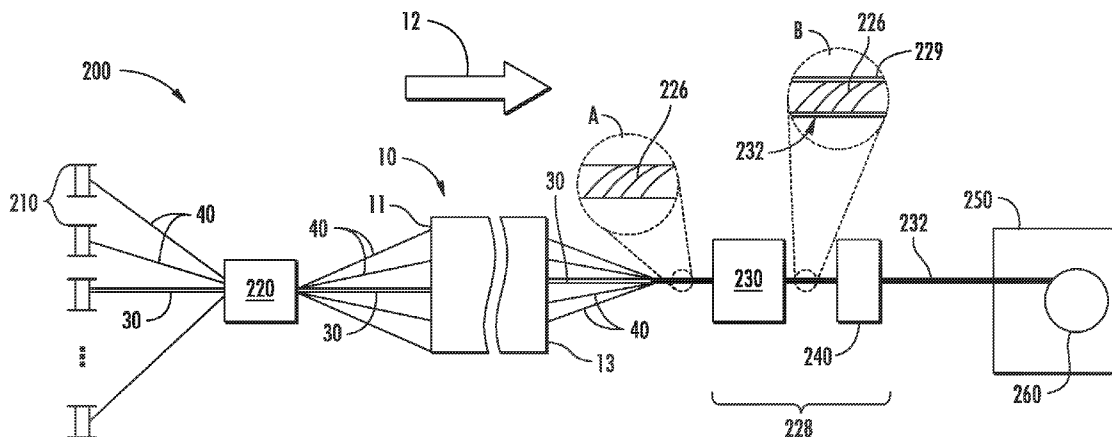

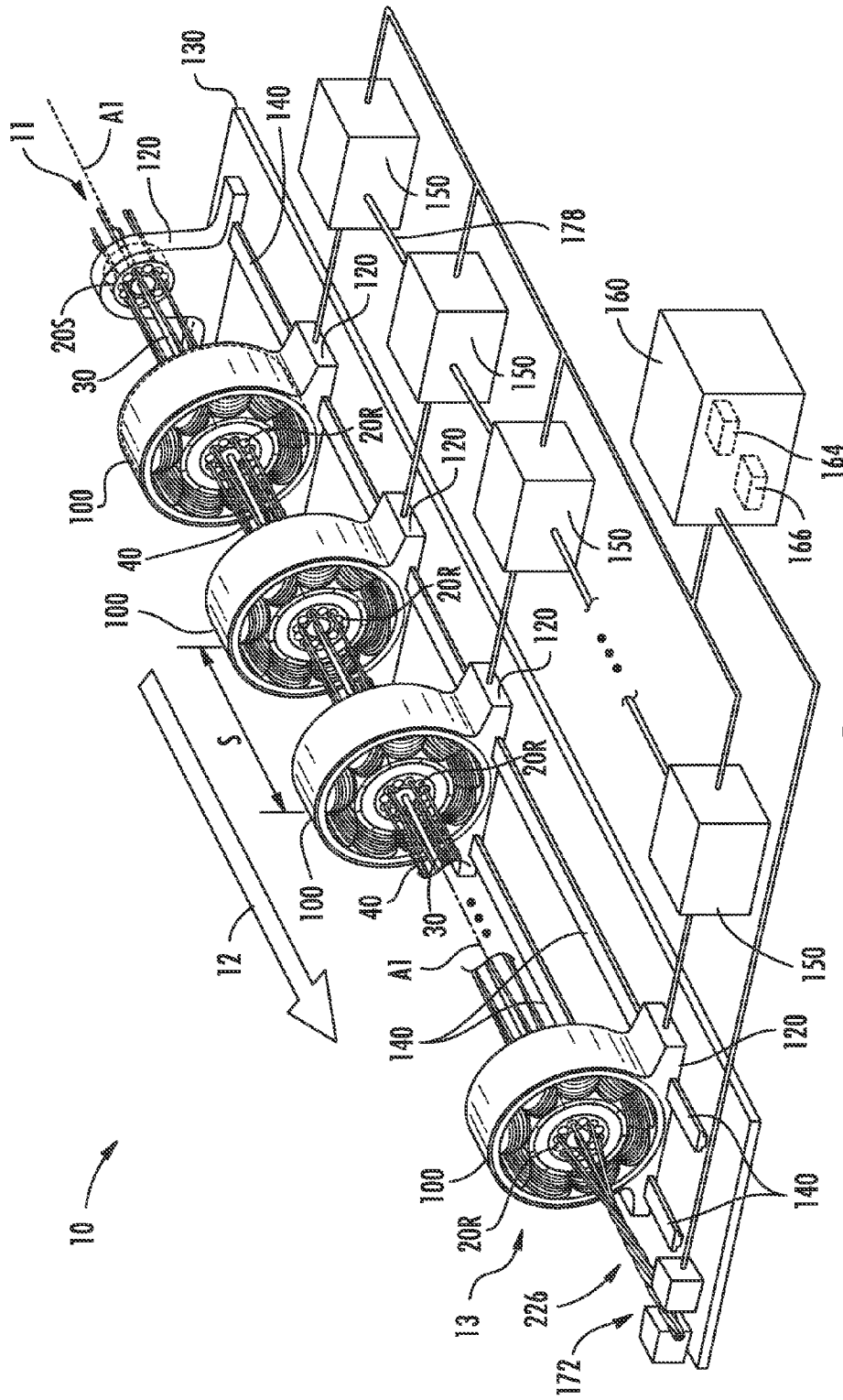

FIG. 1

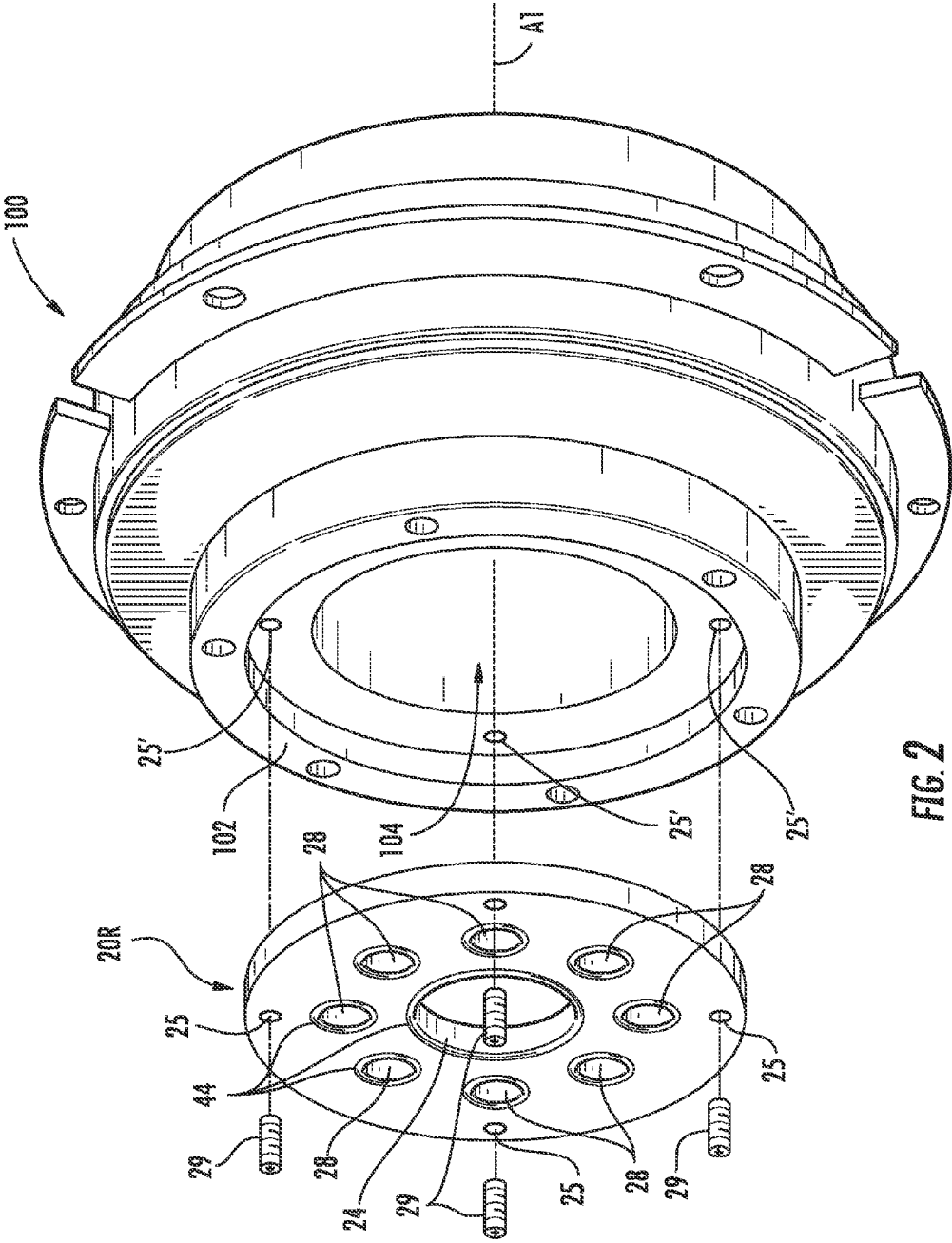

FIG. 2

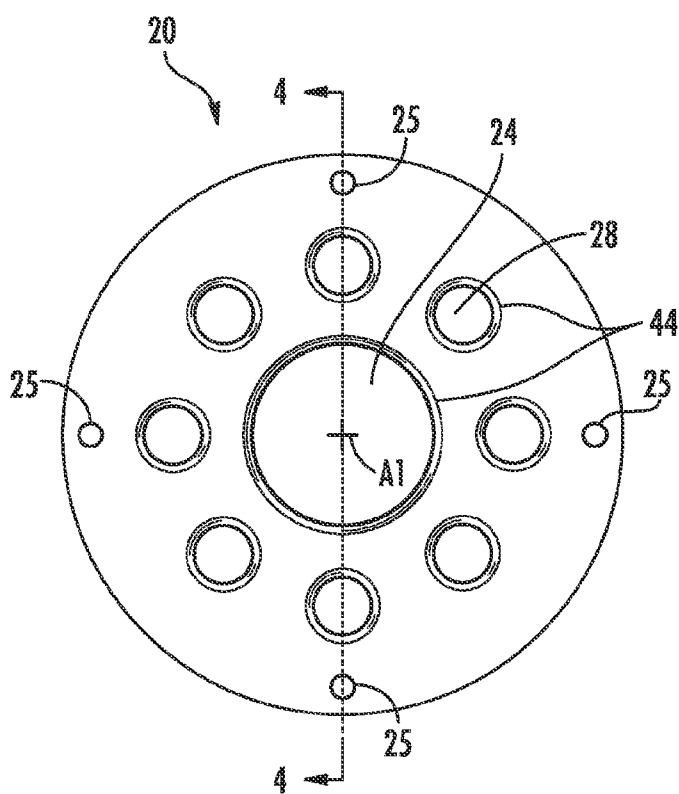

FIG. 3

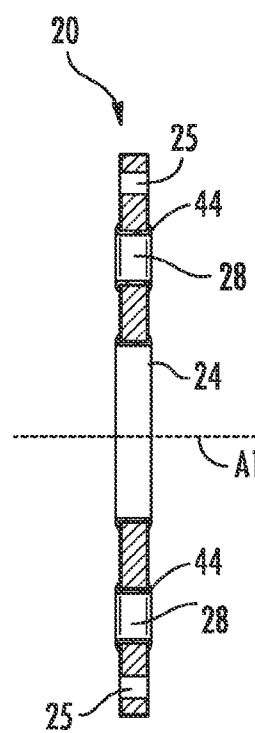

FIG. 4

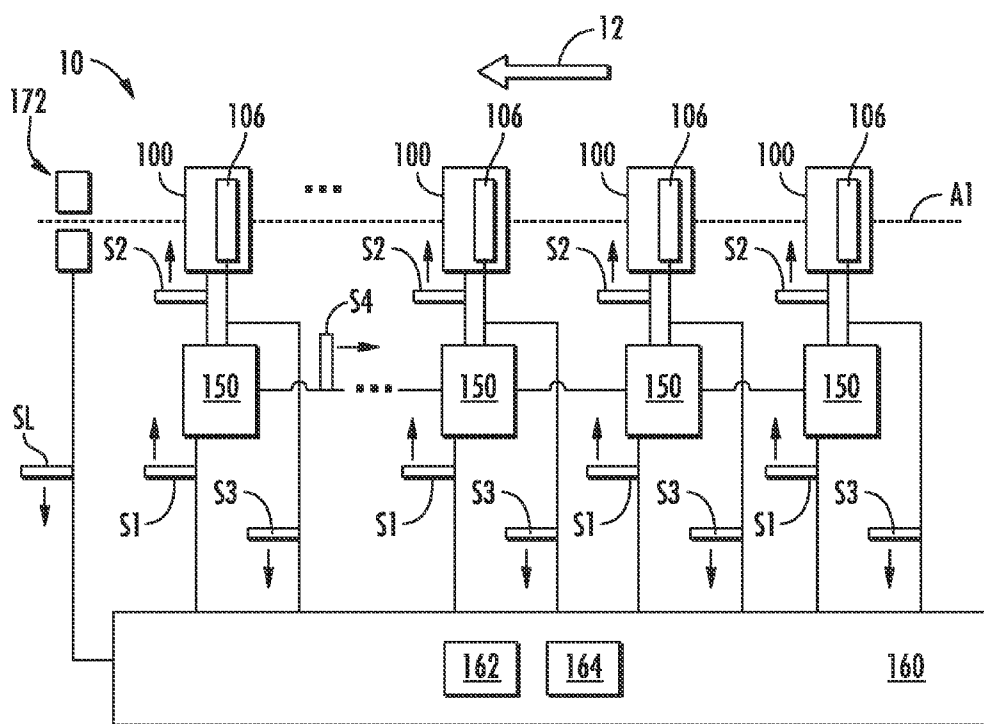

FIG. 5

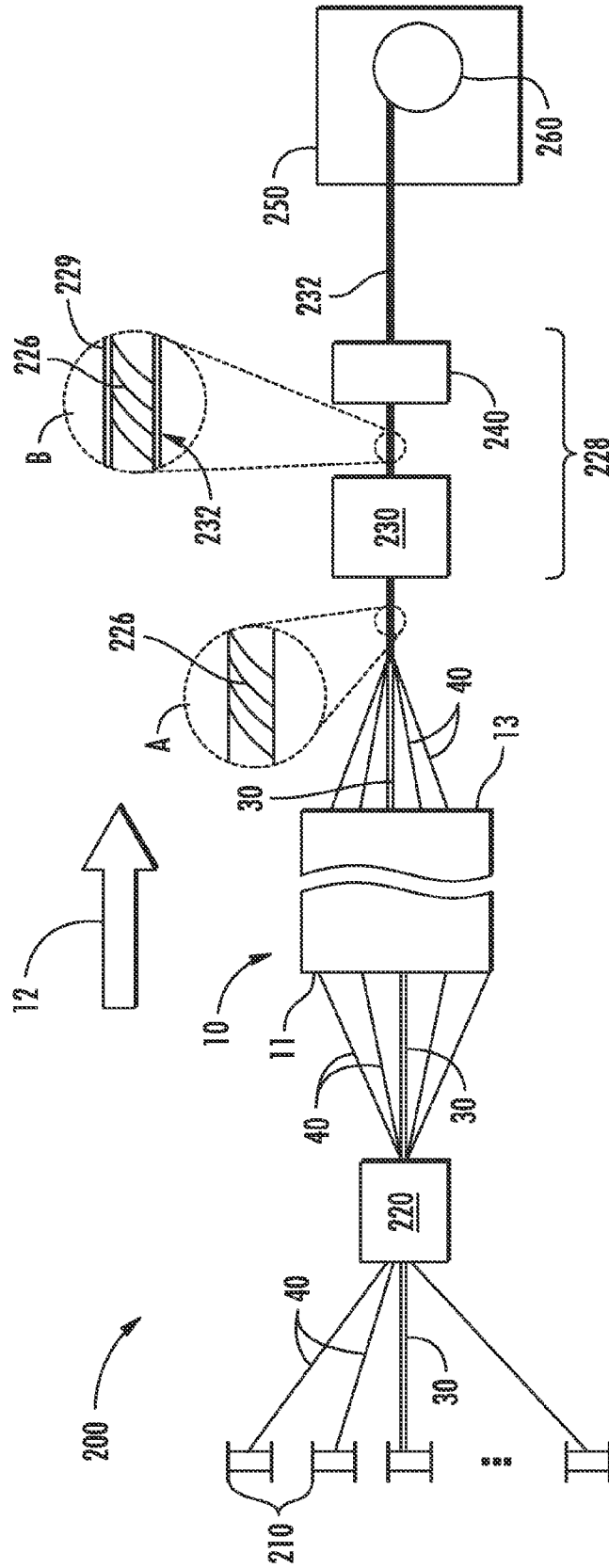

FIG. 6

**CABLE STRANDING APPARATUS  
EMPLOYING A HOLLOW-SHAFT GUIDE  
MEMBER DRIVER**

**CROSS-REFERENCE TO RELATED  
APPLICATIONS**

**[0001]** This application is a continuation of U.S. application Ser. No. 13/442,104, filed on Apr. 9, 2012, which is a continuation-in-part of U.S. application Ser. No. 12/571,104, filed on Sep. 30, 2009, now U.S. Pat. No. 8,161,722, issued on Apr. 24, 2012, and a continuation-in-part of U.S. application Ser. No. 12/571,052, filed on Sep. 30, 2009, now U.S. Pat. No. 8,161,721, issued on Apr. 24, 2012, the content of each of which is relied upon and incorporated herein by reference in their entirety, and the benefit of priority under 35 U.S.C §120 is hereby claimed.

**FIELD**

**[0002]** The present disclosure relates to apparatus for stranding together strand and core members to form stranded cables with an alternating twist direction, and in particular to such apparatus that employ a hollow-shaft guide member driver.

**BACKGROUND**

**[0003]** Cable stranding machines are used in cable manufacturing to form cables with multiple strand elements (“strands”) having an alternating twist direction. Such cables are called “SZ” cables because the strands periodically helically twist in opposing “S” and “Z” directions. The SZ stranding configuration eliminates the need for the strand storage containers to be rotated around the cable core member, thereby resulting in less complex, faster-operating stranding machinery.

**[0004]** The strands, which can be wire, optical fibers, buffer tubes, etc., are stored in storage containers (e.g., spools or “packages”) and pass through a stationary guide or “layplate.” The layplate keeps the strands locally spaced apart as they pass through to a downstream SZ cable-stranding apparatus. Prior art SZ cable-stranding apparatus employ a series of axially arranged and mechanically coupled guides typically in the form of non-stationary (i.e., rotatable) plates called “layplates” similar if not identical to the stationary layplate. The rotatable layplates also serves to keep the strands locally spaced apart during the stranding process to ensure that the strands do not become entangled with each other or the core member as the layplates rotate through their motion profiles.

**[0005]** In the process of forming an SZ-stranded cable, the layplates are mechanically coupled and driven in alternating rotational directions at progressively slower rates towards the upstream stationary plate as the strands move through the layplates. An SZ-stranded assembly, consisting of the strands wound around the central core member, emerges from the most downstream rotatable layplate.

**[0006]** In the simplest form of SZ cable-stranding apparatus, tension in the strands provides the mechanical coupling that rotates the layplates. However, this results in poor tension control with a limited range of layplate rotation. More complex and expensive approaches use a series of shafts from a drive member (“prime mover”) and belts and/or gears to synchronize the motion of the rotating layplates to generate the required rotation rate for each layplate. An example of this

type of SZ cable-stranding apparatus uses an elastic shaft running parallel to the axis of the oscillator. The torsion of the shaft, in combination with an arrangement of belts, pulleys and/or gears, drives the layplates.

**[0007]** Generally, mechanically based SZ cable-stranding apparatus are expensive and difficult to maintain. Furthermore, the added rotational inertia of the mechanical components limits the maximum rate at which the rotatable layplates can reverse directions, thereby limiting both line speed and performance. In addition, the mechanical components limit the relative speed differences between successive layplates. This makes it difficult if not impossible to decouple the operation of the individual layplates to optimize the layplate rotational speeds to achieve the smoothest possible SZ stranding operation.

**SUMMARY**

**[0008]** One embodiment includes a cable-stranding apparatus. The cable-stranding apparatus includes a stationary guide, a motor, a driven guide, and a controller electrically coupled to the motor. The stationary guide is configured to guide strand elements in a spaced-apart configuration and to pass a core member. The motor is operatively associated with a guide driver. The driven guide is disposed at least partially within the guide driver so as to rotate therewith. The driven guide is configured to receive the strand elements from the stationary guide, individually guide the strand elements received from the stationary guide, and to further pass the core member. The controller is electrically coupled to the motor and configured to control the rotational speed and direction of the motor.

**[0009]** Another embodiment includes a cable-stranding apparatus, which includes a motor operatively associated with a guide driver configured to rotationally drive a guide. The guide driver includes a hollow shaft. The guide is disposed at least partially within the guide driver and configured to receive and guide strand elements.

**[0010]** Still another embodiment includes a method of manufacturing a stranding apparatus. The method includes providing a motor having an associated guide driver; and further includes providing and operably disposing a guide at least partially within the guide driver so that the guide rotates with the guide driver. The guide is configured to receive and guide strand elements.

**[0011]** These and other advantages of the disclosure will be further understood and appreciated by those skilled in the art by reference to the following written specification, claims and appended drawings.

**BRIEF DESCRIPTION OF THE DRAWINGS**

**[0012]** A more complete understanding of the present disclosure may be had by reference to the following detailed description when taken in conjunction with the accompanying drawings, wherein:

**[0013]** FIG. 1 is a perspective view of an example SZ cable-stranding apparatus according to the present disclosure;

**[0014]** FIG. 2 is a perspective view of an example hollow-shaft motor showing an exploded view of a guide member attached to the hollow shaft via set screws;

**[0015]** FIG. 3 is a front-on view and FIG. 4 is a cross-sectional view of an example guide member of FIG. 2 in the

form of a layplate having a central hole sized to pass the at least one core member, surrounding strand guide holes, and peripheral set-screw holes;

[0016] FIG. 5 is a schematic diagram of an example electronic configuration of the SZ cable-stranding apparatus; and [0017] FIG. 6 is a schematic overall view of a SZ cable-forming system that includes the SZ cable-stranding apparatus of the present disclosure.

#### DETAILED DESCRIPTION

[0018] Reference is now made to embodiments of the disclosure, exemplary embodiments of which are illustrated in the accompanying drawings. In the description below, like elements and components are assigned like reference numbers or symbols. Also, the terms “upstream” and “downstream” are relative to the direction in which the SZ-stranded cable is formed, starting upstream with the various unstranded strand elements and optional at least one core member, and ending downstream with the formed SZ-stranded assembly and SZ-stranded cable.

[0019] FIG. 1 is a perspective view of an example SZ cable-stranding apparatus (“apparatus”) 10 according to the present disclosure. Apparatus 10 has an upstream input end 11 and a downstream output end 13. Apparatus 10 includes along an axis A1 in order from an upstream to a downstream direction as indicated by arrow 12, a stationary guide member 20S and at least one hollow-shaft motor 100 that includes a rotatable guide member 20R operably disposed therein. Here, the term “rotatable” refers to the fact that motor 100 causes the guide member to rotate, as described in greater detail below. FIG. 1 shows an example configuration of apparatus 10 having a plurality of axially aligned motors 100. An example type of motor 100 is a high-precision motor such as a servo motor.

[0020] In an example embodiment, adjacent motors 100 are spaced apart by respective distances S, which in many cases is governed by space constraints and the fact that larger guide-member separations result in lower tension variation in the strands. A typical spacing S between motors 100 is between 0.1 m and 2 m, and in an example embodiment the spacing is adjustable, as described below. In some example embodiments, the spacing S is equal between all motors 100, while in other example embodiments the spacing S is equal between some motors, while in other example embodiments the spacing S is not equal between any of the motors. Providing a variable spacing S between motors 100 may be used to adjust the stranding process. For example, a large spacing downstream helps minimize tension variation while a short spacing upstream shortens the overall length of apparatus 10 with little impact on tension variation.

[0021] FIG. 2 is a perspective view of an example motor 100. Motor 100 includes a guide member driver in the form of a hollow shaft 102 defined by an axial shaft hole 104 formed therein. An example size of shaft hole 104 is between 1 and 3 inches in diameter, with 2 inches being a commonly available size suitable for use in forming many types of SZ cables. The term “hollow shaft” as used herein in connection with motor 100 is intended to include a motor that contains a through passage concentric with and contained within the rotating structure of the motor. For example, certain types of servo-motors suitable for use herein and discussed in greater detail below include inductively driven rotors that surround and drive a hollow shaft.

[0022] Each motor 100 includes the aforementioned rotatable guide member 20R operably disposed within shaft hole

104 (see FIG. 1) so that the guide member rotates with the rotation of the hollow shaft. In an example embodiment, rotatable guide member 20R is disposed in shaft hole 104 and is fixed to hollow shaft 102 by, for example, by set screws (as described below), an adhesive, a flexible or rigid mounting member or fixture, or other known fixing means.

[0023] Each motor 100 includes a position feedback device 106, such as an optical encoder (see FIG. 5, introduced and discussed below). Positional feedback device 106 provides information (in the form of an electrical signal S3) about the rotational position and speed of hollow shaft 102 and thus rotatable guide member 20R. An example maximum rotational speed of motor 100 is 3,600 rpm and an example maximum theoretical acceleration is 21,582 rad/s<sup>2</sup>. A typical operating rotational speed for motor 100 used in producing SZ cable is about 1,500 rpm with an angular acceleration of about 8,000 rad/s<sup>2</sup>. An exemplary motor 100 for use in apparatus 10 is one of the model nos. CM-4000 hollow-shaft inductively driven servo motors made by Computer Optical Products, Inc., Chatsworth, Calif. Another exemplary motor 100 for use in apparatus 10 is a hollow-shaft gear-based motor, such as those available from Bodine Electric Company, Chicago, Ill.

[0024] FIG. 3 is a face-on view and FIG. 4 is a cross-sectional view of an example guide member 20 that can be used as stationary guide member 20S and/or as rotatable guide member 20R. The example guide member 20 is in the form of a round plate (“layplate”) having a central hole 24 with peripherally arranged smaller guide holes (e.g., eyelets) 28 (six guide holes are shown by way of example). Central hole 24 is sized to pass at least one core member 30 while guide holes 28 are sized to pass individual strand elements (“strands”) 40. Core member 30 includes, for example, a strength element and/or a cable core member. An example strength element is glass-reinforced plastic (GRP), steel or like strength elements presently used in SZ cables. Example cable core members 30 include buffer tubes, optical fibers, optical fiber cables, conducting wires, insulating wires, and like core members presently used in SZ cables. Example strands 40 include optical fibers, buffer tubes, wires, thread, copper twisted pairs, etc.

[0025] Guide member 20 is arranged in apparatus 10 so that central hole 24 is centered on axis A1, and in an example embodiment peripheral guide holes 28 are arranged symmetrically about the central hole. Guide member 20 is configured to maintain the at least one core member 30 and individual strands 40 in a locally spaced apart configuration as the core member and individual strands pass through their respective holes. An example guide member 20 is formed from aluminum. Guide member 20 optionally includes hole liners 44 that line central hole 24 and/or guide holes 28 in a manner that facilitates the passing of core member 30 and/or strands 40 through the guide member. Example materials for hole liners 44 include ceramic, plastic, TEFLON, and like materials. Hole liners 44 preferably have rounded edges that reduce the possibility of core member 30 and/or strands 40 from being snagged, abraded, nicked or cut as they pass through their respective holes. In another example embodiment, central hole 24 and guide holes 28 are provided with rounded edges.

[0026] With reference to FIG. 2 through FIG. 4, in an example embodiment, rotatable guide member 20R includes peripheral set-screw holes 25, and hollow shaft 102 includes



matching screw holes **25'** configured so that the rotatable guide member is attached to the hollow shaft via corresponding set screws **27**.

[0027] In an example embodiment, rotatable guide member **20R** is the same as or is similar to stationary guide member **20S**, and further in an example embodiment are both in the form of layplates such as shown in FIG. 3 and FIG. 4. Motors **100** are axially aligned so that shaft hole **104** and the rotatable guide member **20R** operably disposed therein are centered on axis **A1**.

[0028] With reference again to FIG. 1, in an example embodiment, stationary guide member **20S** and each motor **100** are mounted to respective base fixtures **120**, which in turn are mounted to a common platform **130**, such as a base plate or tabletop. In an example embodiment, base fixtures **120** are configured to be fixed in place to platform **130**, while in another example embodiment they are also configured to be positionally adjustable relative to platform **130**. In one example, the positional adjustability is achieved by slidably mounting base fixtures **120** to rails **140**, which allows for axial adjustability of each motor **100**. Movable motors **100** can be axially moved along rails **140** and placed together for “thread up,” i.e., threading the at least one core member **30** and strands **40** through their respective holes **24** and **28** in the various rotatable guide members **20R**, and then axially moved again along the rails to be spaced apart and fixed at select positions during the SZ stranding operation, as discussed below. The positional adjustability of motors **100** allows for the spacings **S** to be changed so that apparatus **10** can be reconfigured for forming different types of SZ cables or to tune the cable-forming process. In an example embodiment, base fixtures **120** and platform **130** (and optional rails **140**) are configured so that motors **100** can be added or removed from apparatus **10**.

[0029] With continuing reference to FIG. 1 and also to the schematic diagram of FIG. 5, an example apparatus **10** includes at least one servo driver **150** electrically connected to the corresponding at least one motor **100**. Each servo driver **150** is in turn operably connected to a controller **160**. An example controller **160** is a programmable logic controller (PLC), or a microcontroller. An example controller **160** includes a processor **164** and a memory unit **166**, which constitutes a computer-readable medium for storing instructions, such as a rotation relationship embodied as an electronic gearing profile, to be carried out by the processor in controlling the operation of apparatus **10**. An exemplary controller **160** suitable for use in the present disclosure is Model No. PiC900 PLC made by Giddings and Lewis, LLC, Fond du Lac, Wis.

[0030] Apparatus **10** also includes a linespeed monitoring device **172** operably arranged to measure the speed at which the SZ-stranded assembly **226** or core member **30** travels through the apparatus. Example locations for linespeed monitoring device **172** include downstream of the most downstream motor **100** and adjacent SZ-stranded assembly **226** as shown, or upstream of stationary guide member **20S** and adjacent core member **30**. Intermediate locations can also be used. Linespeed monitoring device **172** is electrically connected to controller **160** and provides a linespeed signal **SL** thereto. An example linespeed monitoring device **172** is the BETA QUADRATRAK II linespeed monitor, available from Beta LaserMike USA, Inc., Dayton, Ohio.

[0031] In an example embodiment, controller **160** includes instructions (i.e., is programmed with instructions stored in

memory unit **166**) that control the rotational speed and the reversal of rotation of each motor **100** according to a rotation relationship. This rotation relationship between motors **100** is accomplished via motor control signals **S1** provided by controller **160** to the corresponding servo drivers **150**. In an example embodiment, the rotation relationship is embodied as electronic gearing. In response thereto, each servo driver **150** provides its corresponding motor **100** with a power signal **S2** that powers the motor and drives it at a select speed and rotation direction according to the rotation relationship. Position feedback device **106** provides a position signal **S3** that in an example embodiment includes incremental positional information, speed information, and an absolute (reference) position. The reference position is typically a start position of hollow shaft **102**, while the incremental position tracks its rotational position on a regular basis (e.g., 36,000 counts per rotation). The rotational speed of hollow shaft **102** is the change in rotational position with time and is obtained from the position information contained in signal **S3**. Linespeed signal **SL** provides linespeed information, which is useful for comparing to the rotational speeds of motors **100** to ensure that the rotational speed and linespeed are consistent with the operational parameters of apparatus **10** and the particular SZ-cable being fabricated.

[0032] For apparatus **10** having a plurality of motors **100**, each motor has a different rotational speed, with less rotational speed the farther upstream the motor resides. For an SZ stranded cable, the number  $n$  of “turns between reversals” can vary, with a typical number being  $n=8$ . For this example number of turns between reversals, apparatus **10** starts at a neutral point ( $n=0$ ) where all of the strands **30** and the rotational and stationary guide members **20R** and **20S** are aligned. Controller **160**, through the operation of servo drivers **150**, then causes motors **100** to execute four turns clockwise, and then reverse and execute eight turns counterclockwise. Note that after the first four counterclockwise turns, apparatus **10** returns to and then passes through the neutral point. After the eight counterclockwise turns, apparatus **10** reverses and performs eight clockwise turns. In this way,  $n=8$  turns between reversals is obtained, with rotatable guide members **20R** turning four turns around the neutral point in each direction.

[0033] For apparatus **10** designed to operate with a maximum angular deviation of  $120^\circ$  between two successive rotatable guide members **20R**, the  $120^\circ$  needs to be divided between four turns, or  $30^\circ$  per turn. Thus, as the “first” or most downstream rotatable guide member **20R** undergoes its first revolution, the second (i.e., second most downstream rotatable guide member) must lag the first by  $30^\circ$ , i.e., it only turns  $11/12$  (i.e., 0.92) of a revolution. This defines the base rotation ratio  $R$ , i.e., the range of rotation between the second and first most downstream motors.

[0034] Consider an example for  $n=+/-4$  turns and a maximum angular displacement between two rotatable guide members **20R** of  $\theta_{MAX}=120^\circ$ . The first rotatable guide member turns a total angle of  $\theta_T=1440^\circ$  ( $n*360$ ), the second turns  $1320^\circ$ , the third  $1200^\circ$  and so on. The second rotatable guide member **20R** is then driven at a ratio  $R_2=1320/1440=0.92$ . The third guide member **20R** is driven at a ratio  $R_3=1200/1320$  or 0.91. Generally, for  $j$ —the rotatable guide member number,  $\theta_{MAX}$ —the separation angle,  $\theta_T$ —the total angular rotation ( $n*360^\circ$ ) for the first guide member, the rotation ratio of guide member  $j=2, 3, \dots$  relative to the first guide member is given by  $R_j=1-(j-1)*\theta_{MAX}/\theta_T$ .

[0035] Example rotation relationships for motors **100** are carried out in a similar manner for different numbers  $n$  of turns between reversals, a different total number  $m$  of motors, and a different maximum angular deviation  $\theta_{MAX}$  between adjacent guide members. The number  $m$  of motors **100** needed in apparatus **10** generally depends on the type of SZ cable being formed and related factors, such as the maximum number  $n$  of turns between reversals, and  $\theta_{MAX}$ , which in turn depends on the guide member diameter, the size of the core member **30** and the size of strands **40**. A typical number  $m$  of motors **100** ranges from 1 to 20, with between 5 and 12 being a common number for a wide range of SZ cable applications.

[0036] Apparatus **10** can be configured and operated in a number of ways. For example, rather than controller **160** controlling each individual servo driver **150**, in one embodiment the servo drivers are linked together via a communication line **178** and receive information about the rotation of the most downstream motor **100** via an electrical signal **S4**. The upstream servo drivers **150** then calculate the required motor signals **S2** needed to provide the appropriate rotation relationship (e.g., via electronic gearing) to their respective motors **100**. Thus, controller **160** transmits information via signal **S1** about the stranding profile ( $n$  turns between reversals, the laylength, etc. . . .) to the first (i.e., most downstream) servo driver **150**. Each upstream servo driver **150** receives a master/slave profile (e.g. a gear ratio= $R$ ) for the motor **100** immediately in front of it via respective signals **S4**. Thus, the upstream servo drivers **150** are slaved to the most downstream servo driver. In this embodiment, controller **160** is mainly for initiating and then monitoring the operation of apparatus **10**. Linespeed information is provided to the most downstream servo driver **150** through controller **160** (i.e., from linespeed monitoring device **178** to controller **160** and then to the most downstream servo driver).

[0037] In a related embodiment, controller **160** transmits the aforementioned stranding profile information via signal **S1** to first servo driver **150**, while each upstream servo driver receives a master/slave profile (e.g. a gear ratio= $R$ ) that synchronizes them to the downstream servo driver. Since each upstream servo driver **150** is slaved to the most downstream servo driver, each servo driver requires the position feedback data from the first motor **100**. Linespeed information is provided to the first servo driver **150** through controller **160**.

[0038] In another related embodiment, controller **160** transmits the aforementioned stranding profile information to the first servo driver **150**. Controller **160** also calculates an individualized stranding profile for each upstream motor **100** based on the complete stranding profile that will result in a desired operation for apparatus **10**. In this case, there are no rotational master/slave relationships between motors **100**. Since each motor **100** operates independently of the others, each requires linespeed feedback from linespeed monitoring device **178** and only its own position information. In an example embodiment, the linespeed feedback is provided via controller **160**.

[0039] Thus, in one embodiment, each motor **100** is programmed to rotate with a select speed that is not necessarily slaved off the “base” rotation ratio  $R$ . In an example embodiment, the rotation relationship between the motors has a non-linear form selected to optimize the SZ stranding process. The rotation relationship between two adjacent rotatable guide members **20R** can best be visualized as a function of the angular position  $\theta_M$  of a “master” guide member **20R** and the angular position  $\theta_S$  of a corresponding “slave” guide

members. Thus, for a prior art mechanical system where the rotation ratio  $R$  is fixed, the angular position  $\theta_S$  of the slave guide member is determined by the function  $\theta_S=R*\theta_M$ , which is a linear function in  $\theta$ . In contrast, the rotation relationship programmed into controller **160** can allow for a much more complex functional relationships between the angular positions and rotation speeds of guide members **20**. A non-linear rotation relationship is useful, for example, to minimize tension spikes that can occur during the SZ stranding operation.

[0040] FIG. **6** is a schematic diagram of an example SZ cable-forming system (“system”) **200** that includes apparatus **10** of the present disclosure. System **200** includes strand storage containers **210**, typically in the form of spools or “packages” that respectively hold and pay off individual strands **40** and optionally one or more individual core members **30**.

[0041] System **200** include a strand-guide device **220** arranged immediately downstream of strand storage containers **210**. In an example embodiment, strand-guide device **220** includes a series of pulleys (not shown) that collect and distribute the strands **40** and the at least one core member **30**. SZ cable-stranding apparatus **10** is arranged immediately downstream of strand-guide device **220** and receives at its input end **11** the strands **40** and the at least one core member **30** outputted from the strand-guide device. Apparatus **10** then performs SZ-stranding of the strands about the at least one core member **30**, as described above. Strands **40** and the optional core member **30** exit apparatus **10** at output end **13** as an SZ-stranded assembly **226**, as shown in the close-up view of inset A of FIG. **6** (see also FIG. **1**). SZ-stranded assembly **226** consists of strands **40** wound around the at least one core member **30** in an SZ configuration.

[0042] System **200** includes a coating unit **228** arranged immediately downstream of apparatus **10**. Coating unit includes an extrusion station **230** configured to receive the SZ-stranded assembly **226** and form a protective coating **229** thereon, as shown in the close-up view of inset B in FIG. **6**, thereby forming the final SZ cable **232**. In an example embodiment, extrusion station **230** includes a cross-head die (not shown) configured to combine the protective coating extrusion material with the SZ-stranded assembly. Example coatings **228** include polyethylene (PE), polyvinyl chloride (PVC), Poly Vinyl Diene Fluorine (PVDF), Nylon, Poly Tetra Flouro Ethylene (PTFE), etc. Coating unit **228** also includes a cooling and drying station **240** is arranged immediately downstream of extrusion station and cools and dries coating **228**. The final SZ cable **232** emerges from coating unit **228** and is received by a take-up unit **250** that tensions the SZ cable and winds it around a take-up spool **260**.

[0043] Apparatus **10** of the present disclosure eliminates the mechanical coupling between rotatable guide members **20R** and in this sense is a gearless and shaftless apparatus. Note that the strands **40** passing through the rotatable guide members **20R** do not establish a mechanical coupling between the guide members because the strands are not used to drive the rotation of the guide members. Without the added rotational inertia and bearing friction associated with mechanical components, faster reversal times and thus higher line speeds are possible for a given lay length. Gear-based SZ cable-stranding apparatus are also subject to extremely high dynamic loads during the reversals. This puts a great deal of stress on the power transmission gears, resulting in frequent

maintenance issues. The gearless/shaftless SZ cable-stranding apparatus 10 eliminate these types of maintenance and reliability issues.

[0044] Because the motion of rotatable guide members 20R is electronically controlled, their rotational velocities in relation to other plates is programmable according to a rotation relationship to carry out rotation profiles (including complex rotation profiles) that result in smoother operation and lower tension variations on strands 40 and the at least on core member 30. The prior art mechanical approaches limit the rotation profiles of the rotatable guide members, which causes unwanted variations in strand tension.

[0045] It will be apparent to those skilled in the art that various modifications to the present embodiment of the disclosure as described herein can be made without departing from the spirit or scope of the disclosure as defined in the appended claims. Thus, the disclosure covers the modifications and variations provided they come within the scope of the appended claims and the equivalents thereto.

What is claimed is:

1. A cable-stranding apparatus, comprising:

- a stationary guide configured to guide strand elements in a spaced-apart configuration and to pass a core member;
- a motor operatively associated with a guide driver, wherein the guide driver includes a hollow shaft having a through-passage contained within a rotating structure of the motor;
- a driven guide disposed at least partially within the guide driver so as to rotate therewith, the driven guide configured to receive and individually guide the strand elements received from the stationary guide, and to further pass the core member; and
- a controller electrically coupled to the motor and configured to control the rotational speed and direction of the motor.

2. The apparatus of claim 1, wherein the rotating structure of the motor includes inductively-driven rotors that surround and drive the hollow shaft.

3. The apparatus of claim 2, wherein a rotational inertia of the motor is reduced compared to a similar mechanically-driven motor.

4. The apparatus of claim 1, wherein the controller operates the motor according to a rotation relationship that defines rotation speed and direction as a function of at least one of time and line speed.

5. The apparatus of claim 1, wherein the motor comprises a servo motor, and the controller is electrically coupled to the servo motor through a corresponding servo driver.

6. A cable-stranding apparatus, comprising a low-inertia motor operatively associated with a guide driver configured to rotationally drive a guide, wherein the guide driver comprises a hollow shaft having a through-passage contained within a rotating structure of the motor, and the guide is disposed at least partially within the guide driver and configured to receive and guide strand elements.

7. The apparatus of claim 8, wherein the motor comprises a servo motor.

8. The apparatus of claim 9, further comprising a controller electrically coupled to the servo motor through a servo driver

9. The apparatus of claim 8, wherein the guide comprises a layplate having peripheral guide holes configured to individually guide the strand elements and a central guide hole to pass a core member.

10. The apparatus of claim 8, wherein the rotating structure of the motor includes inductively-driven rotors that surround and drive the hollow shaft to reduce a rotational inertia of the motor.

11. A method of manufacturing a stranding apparatus, comprising: providing a motor having an associated guide driver, wherein the guide driver comprises a hollow shaft having a through-passage contained within a rotating structure of the motor; and providing and operably disposing a guide at least partially within the guide driver so that the guide rotates with the guide driver, wherein the guide is configured to receive and guide strand elements.

12. The method of claim 11, wherein providing the guide comprises providing the guide as a layplate having peripheral guide holes for guiding the strand elements and a central hole that passes a core member.

13. The method of claim 12, wherein the rotating structure of the motor includes inductively-driven rotors that surround and drive the hollow shaft with reduced rotational inertia.

14. The method of claim 13, further comprising providing the motor as a servo motor.

15. The method of claim 14, further comprising providing a servo-driver and electrically connecting the servo-driver to the servo motor, and providing a controller and electrically connecting the controller to the servo driver.

\* \* \* \* \*