



(19) **United States**

(12) **Patent Application Publication**

LEE et al.

(10) **Pub. No.: US 2019/0355707 A1**

(43) **Pub. Date: Nov. 21, 2019**

(54) **STACKED SEMICONDUCTOR PACKAGE HAVING MOLD VIAS AND METHOD FOR MANUFACTURING THE SAME**

H01L 21/78 (2006.01)
H01L 25/065 (2006.01)

(52) **U.S. Cl.**
CPC *H01L 25/18* (2013.01); *H01L 23/49816* (2013.01); *H01L 21/56* (2013.01); *H01L 24/16* (2013.01); *H01L 23/5386* (2013.01); *H01L 25/50* (2013.01); *H01L 24/03* (2013.01); *H01L 24/95* (2013.01); *H01L 21/568* (2013.01); *H01L 23/3128* (2013.01); *H01L 23/3135* (2013.01); *H01L 24/05* (2013.01); *H01L 23/481* (2013.01); *H01L 23/3142* (2013.01); *H01L 21/78* (2013.01); *H01L 21/563* (2013.01); *H01L 25/0652* (2013.01); *H01L 24/81* (2013.01); *H01L 2224/0612* (2013.01); *H01L 2924/1431* (2013.01); *H01L 2924/1434* (2013.01); *H01L 21/561* (2013.01)

(71) Applicant: **SK hynix Inc.**, Icheon-si Gyeonggi-do (KR)

(72) Inventors: **Sang-Eun LEE**, Yongin-si Gyeonggi-do (KR); **Hyung-Dong LEE**, Yongin-si Gyeonggi-do (KR); **Eun KO**, Seoul (KR)

(73) Assignee: **SK hynix Inc.**, Icheon-si Gyeonggi-do (KR)

(21) Appl. No.: **16/528,938**

(22) Filed: **Aug. 1, 2019**

Related U.S. Application Data

(62) Division of application No. 15/715,449, filed on Sep. 26, 2017, now Pat. No. 10,418,353.

Foreign Application Priority Data

May 11, 2017 (KR) 10-2017-0058458

Publication Classification

(51) **Int. Cl.**
H01L 25/18 (2006.01)
H01L 21/56 (2006.01)
H01L 23/00 (2006.01)
H01L 23/538 (2006.01)
H01L 25/00 (2006.01)
H01L 23/31 (2006.01)
H01L 23/48 (2006.01)

(57) **ABSTRACT**

A stacked semiconductor package includes a first semiconductor chip having a first active surface over which first bonding pads including peripheral bonding pads and central bonding pads are arranged, a first encapsulation member, two second semiconductor chips having second active surfaces over which second bonding pads are arranged at one side peripheries and disposed to be separated from each other such that the second active surfaces face the first active surface and the second bonding pads overlap with the peripheral bonding pads, first coupling members interposed between the peripheral bonding pads and the second bonding pads, a second encapsulation member formed over second side surfaces of the second semiconductor chips including a region between the second semiconductor chips, and a mold via formed through a portion of the second encapsulation member in the region between the second semiconductor chips and coupled with the central bonding pads.

400

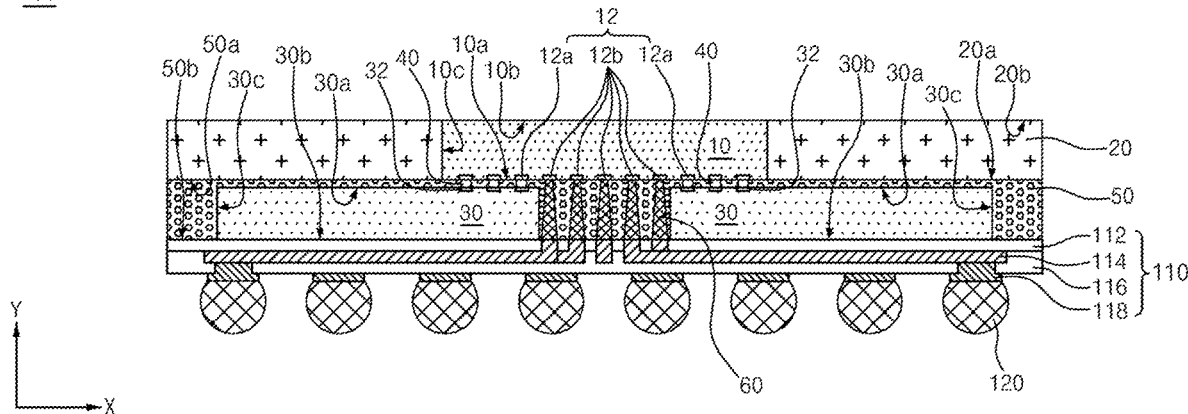

FIG. 1

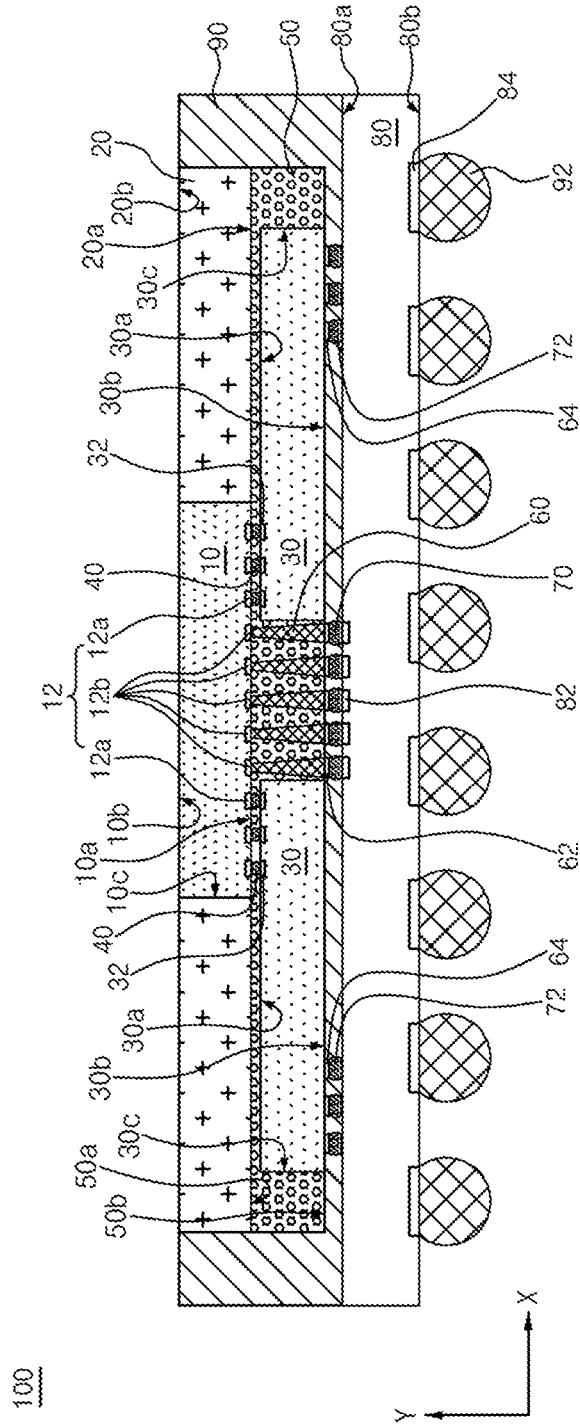

FIG.2A

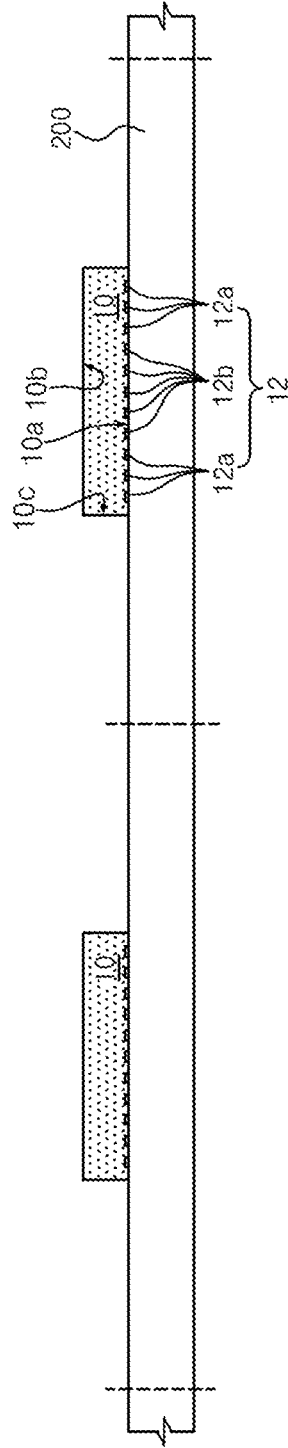

FIG.2B

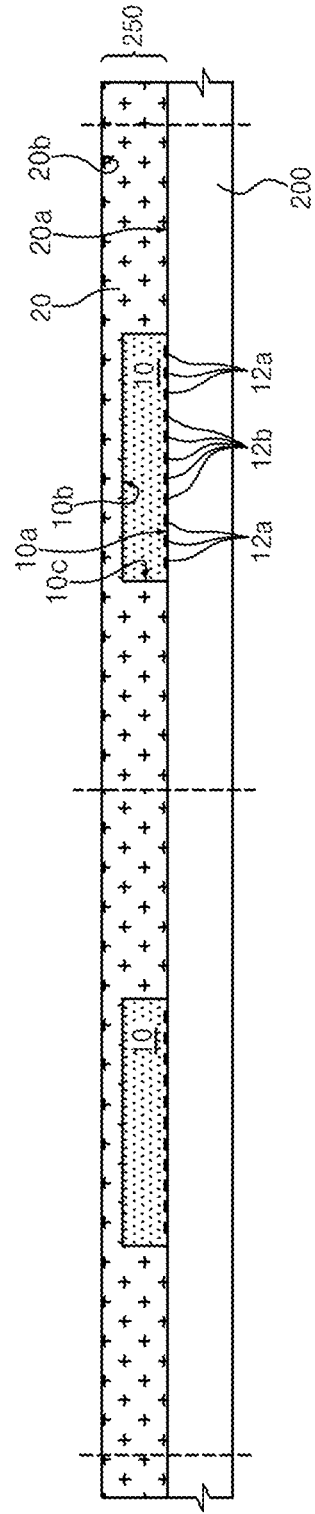

FIG.2C

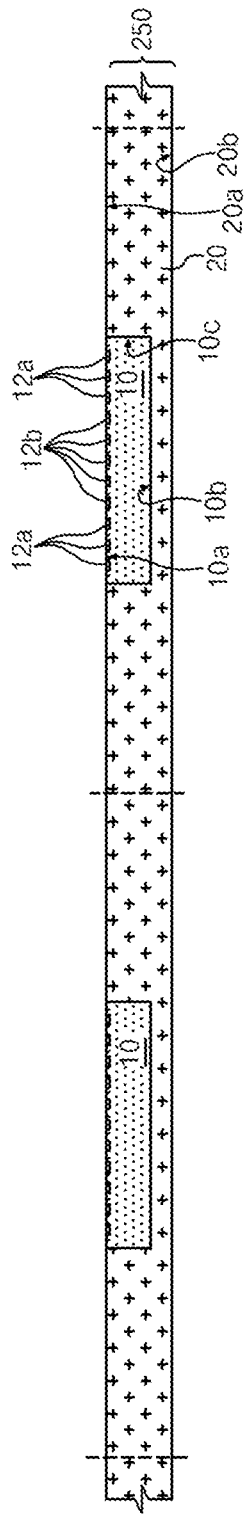

FIG.2D

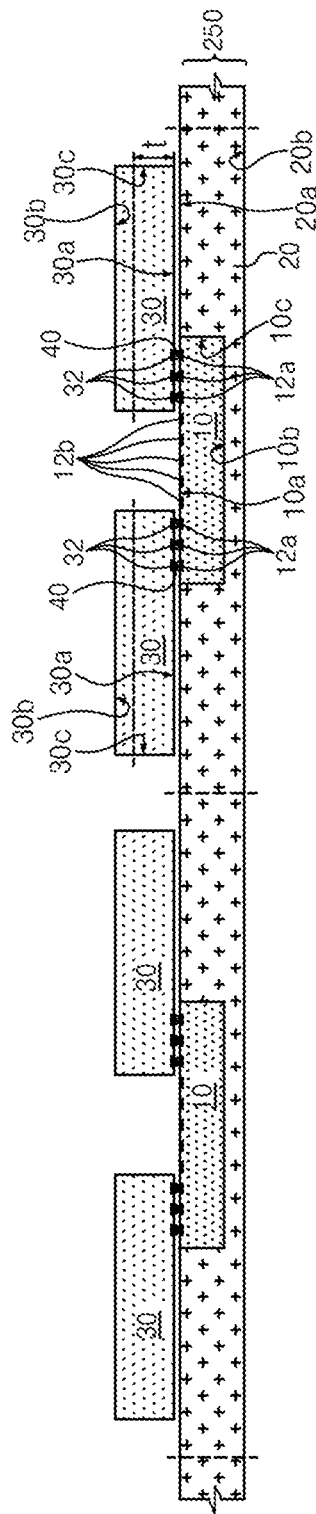

FIG. 2E

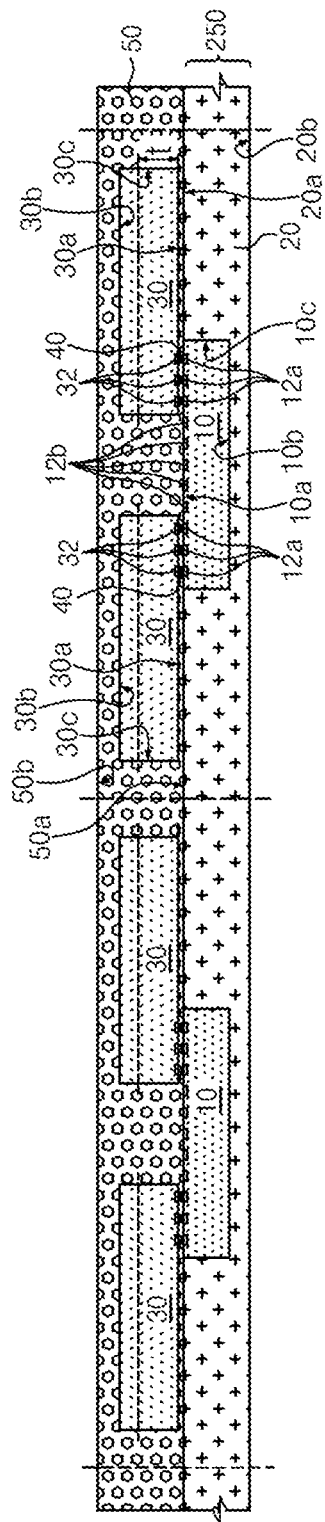

FIG. 2F

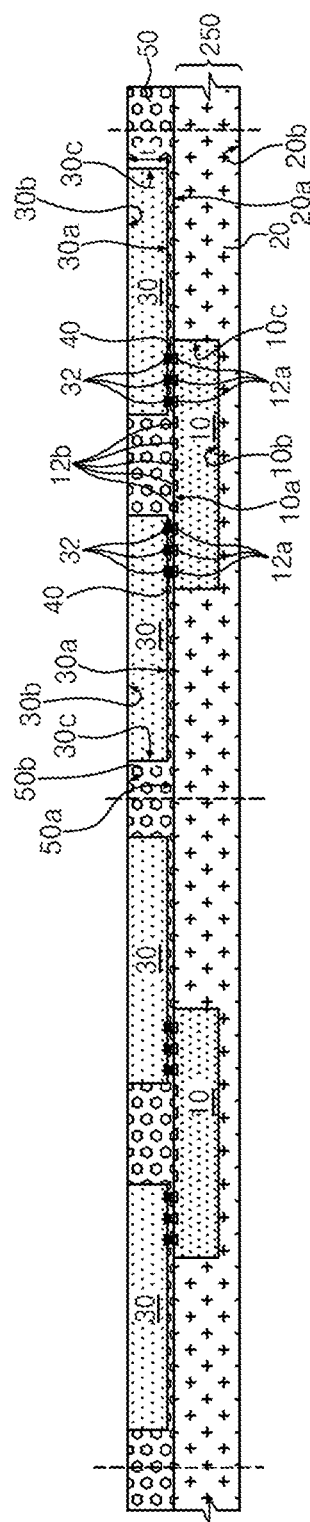

FIG. 2G

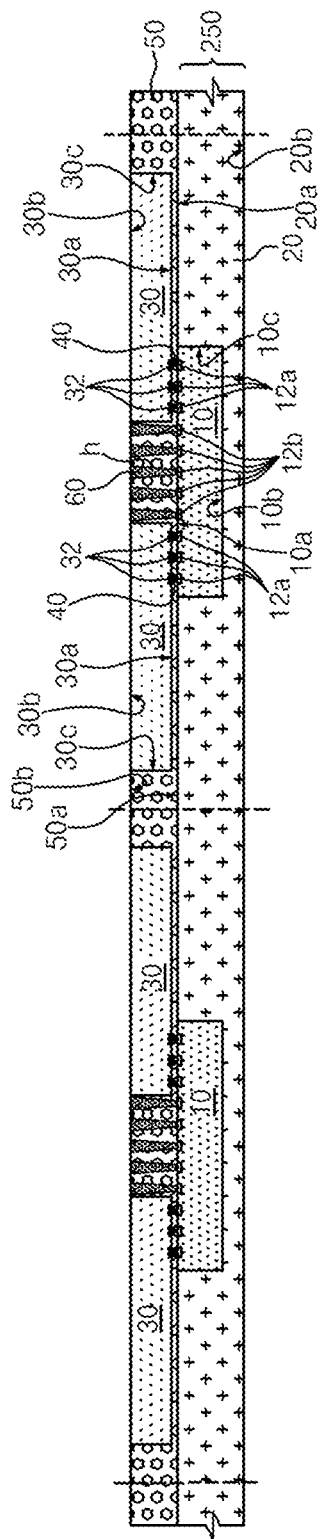

FIG. 2H

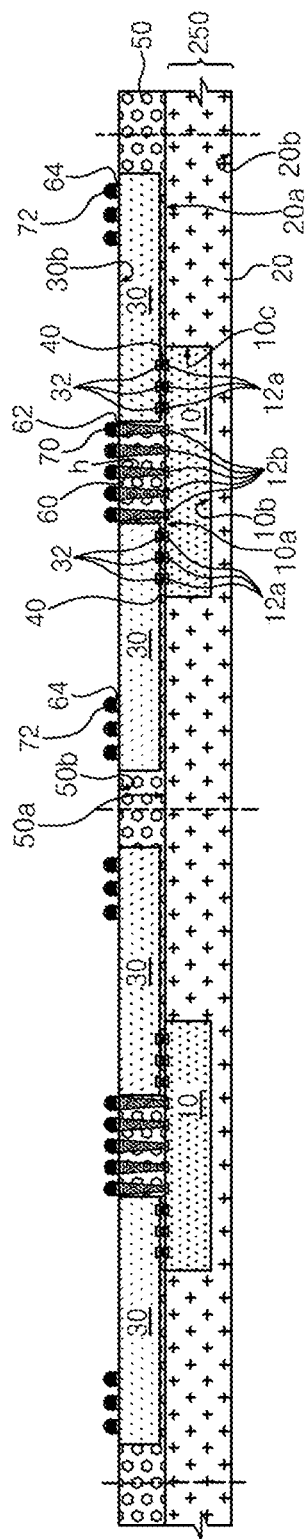

FIG.2I

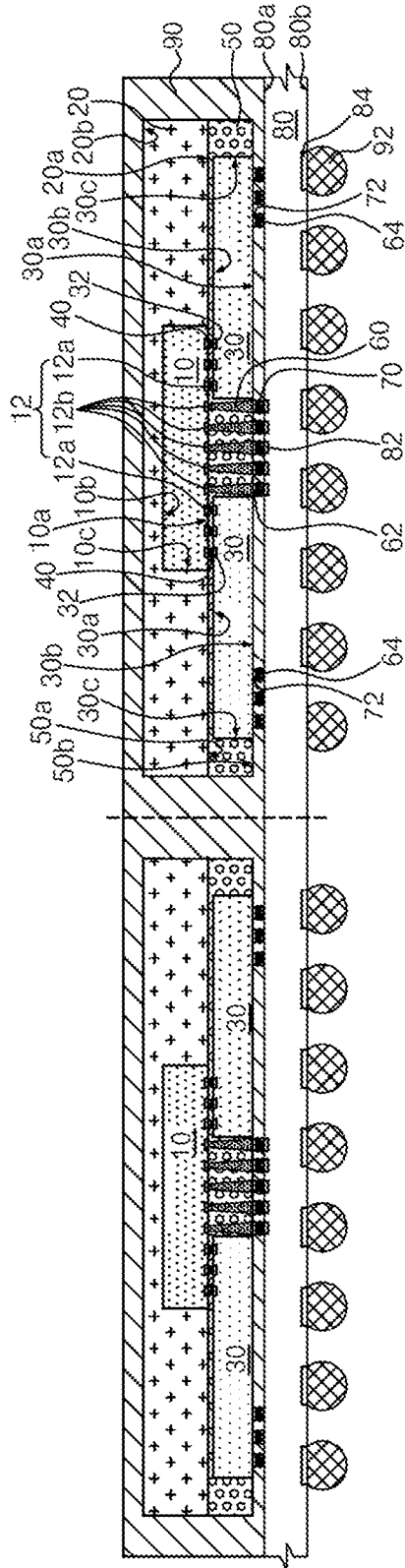

FIG.2J

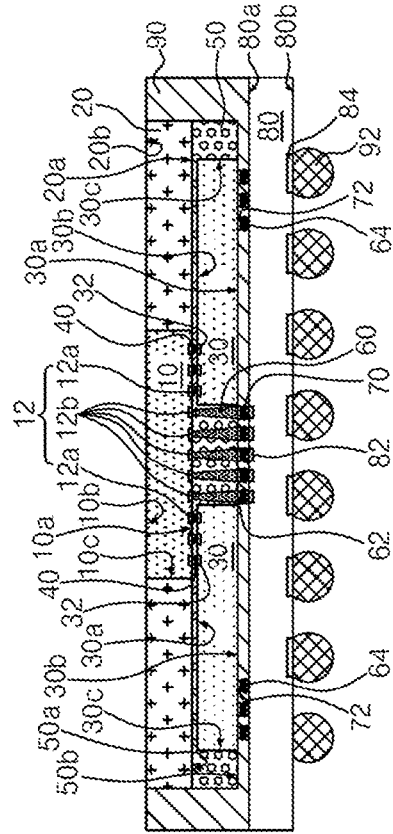
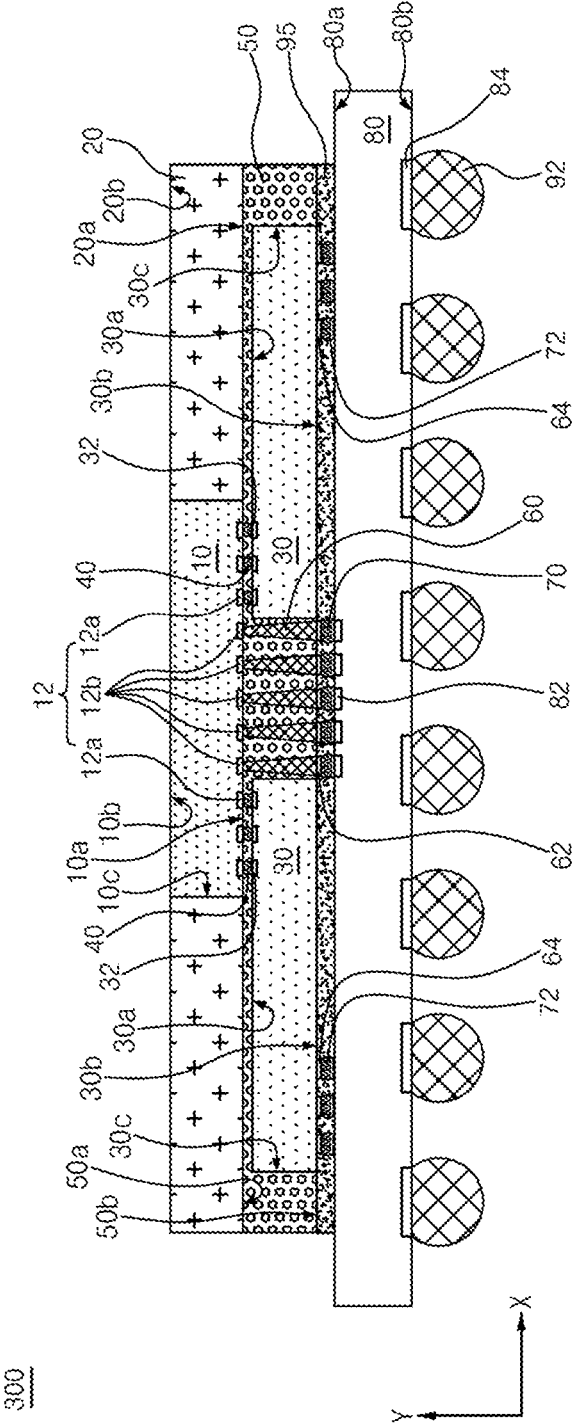
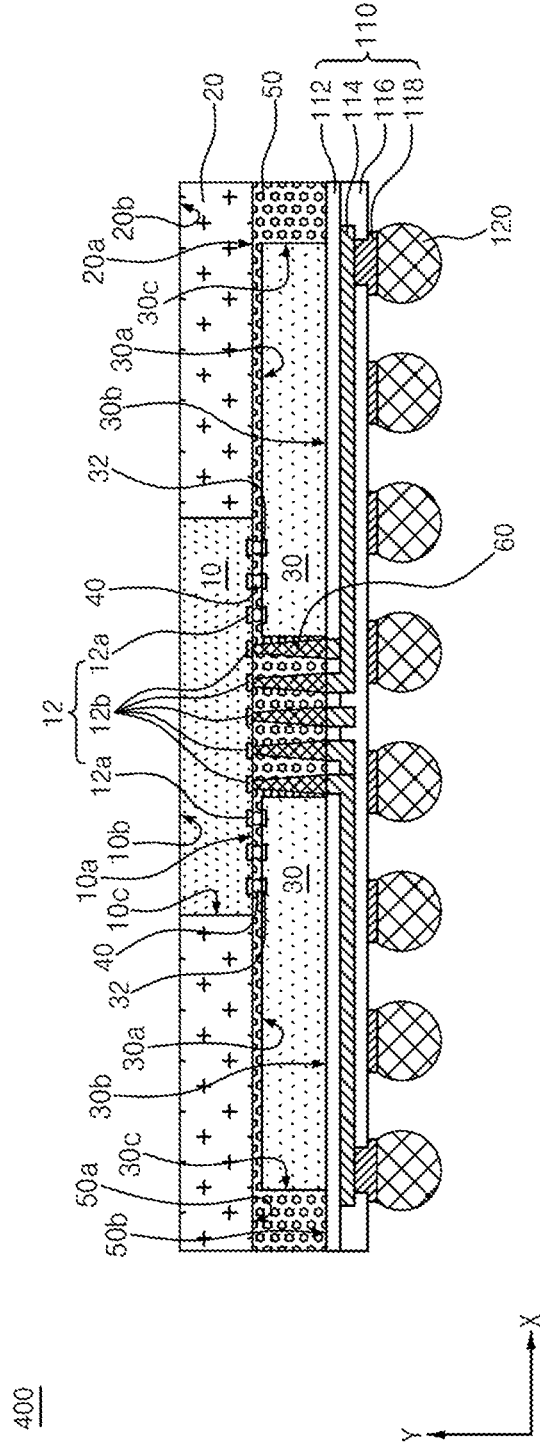

FIG. 3



300

FIG. 4



400

FIG. 5

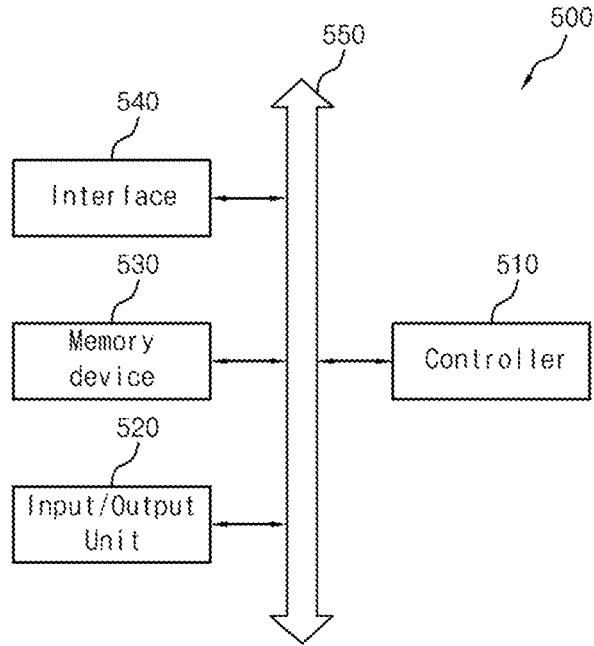
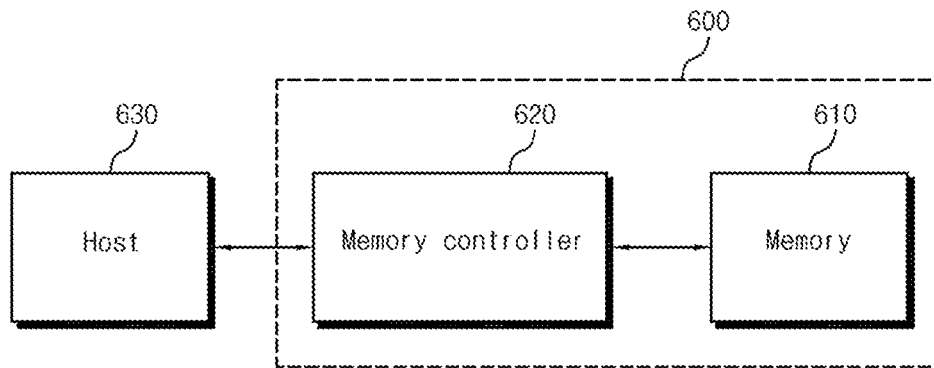

FIG. 6



**STACKED SEMICONDUCTOR PACKAGE
HAVING MOLD VIAS AND METHOD FOR
MANUFACTURING THE SAME**

CROSS-REFERENCE TO RELATED
APPLICATION

[0001] The present application is a divisional application of U.S. patent application Ser. No. 15/715,449, filed on Sep. 26, 2017, and claims priority to Korean Patent Application No. 10-2017-0058458 filed on May 11, 2017, in the Korean Intellectual Property Office, which is incorporated herein by reference in its entirety.

BACKGROUND

1. Technical Field

[0002] Various embodiments generally relate to a semiconductor package, and more particularly, to a stacked semiconductor package having mold vias and a method for manufacturing the same.

2. Related Art

[0003] As electronic products become smaller and more sophisticated, semiconductor chips with higher capacities have been needed to meet required functions. In addition, it has become necessary to mount an increased number of semiconductor chips in a smaller-sized electronic product.

[0004] But, technologies for manufacturing semiconductor chips with higher capacities or mounting an increased number of semiconductor chips in a limited space cannot help but have limitations. In this situation, a recent trend is directed to embedding an increased number of semiconductor chips in one package.

[0005] In this regard, technologies capable of embedding different kinds of chips in one package and stacking two or more chips while not increasing the entire thickness of the package are being developed. Also, various technologies capable of improving electrical characteristics of stacked semiconductor chips are being developed.

SUMMARY

[0006] In an embodiment, a stacked semiconductor package may include a first semiconductor chip having a first active surface over which first bonding pads including peripheral bonding pads and central bonding pad are arranged. The stacked semiconductor package may include a first encapsulation member formed over at least first side surfaces of the first semiconductor chip. The stacked semiconductor package may include two second semiconductor chips having second active surfaces over which second bonding pads are arranged at side peripheries adjacent to the first semiconductor chip, and disposed to be separated from each other such that the second active surfaces face the first active surface and the second bonding pads overlap with the peripheral bonding pads. The stacked semiconductor package may include first coupling members interposed between the peripheral bonding pads of the first semiconductor chip and the second bonding pads of the second semiconductor chips. The stacked semiconductor package may include a second encapsulation member formed over second side surfaces of the second semiconductor chips including a region between the second semiconductor chips. The stacked semiconductor package may include a mold via

formed through a portion of the second encapsulation member in the region between the second semiconductor chips and coupled with the central bonding pads.

[0007] In an embodiment, a method for manufacturing a stacked semiconductor package may include: disposing first semiconductor chips having first active surfaces over which first bonding pads including peripheral bonding pads and central bonding pad are arranged, over a carrier wafer such that the carrier wafer and the first active surfaces face each other; forming a first encapsulation member which covers the first semiconductor chips, over the carrier wafer such that a reconfigured wafer in which the first semiconductor chips are redispersed is constructed; removing the carrier wafer from the reconfigured wafer; bonding two second semiconductor chips to one first semiconductor chip on the reconfigured wafer at a distance from each other, wherein the second semiconductor chips have second active surfaces over which second bonding pads are arranged at side peripheries adjacent to the first semiconductor chip, wherein the second semiconductor chips have first coupling members formed on the second bonding pads, wherein the second semiconductor chips possess a thickness greater than a target thickness, and wherein the second semiconductor chips are disposed on the reconfigured wafer, such that the second active surfaces face the first active surface, the second bonding pads are coupled with the peripheral bonding pads by the first coupling members and the central bonding pad is exposed; forming a second encapsulation member over the reconfigured wafer in such a way as to cover the second semiconductor chips; removing a partial thickness of the second encapsulation member and the second semiconductor chips such that the target thickness of the second semiconductor chips remains; and forming a mold via which is coupled with the central bonding pads of the first semiconductor chip, and which pass through a portion of the second encapsulation member in a region between the second semiconductor chips.

BRIEF DESCRIPTION OF THE DRAWINGS

[0008] FIG. 1 is a cross-sectional view illustrating a representation of an example of a stacked semiconductor package in accordance with an embodiment.

[0009] FIGS. 2A to 2J are representations of examples of cross-sectional views to assist in the explanation of the processes of a method for manufacturing a stacked semiconductor package in accordance with an embodiment.

[0010] FIG. 3 is a cross-sectional view illustrating a representation of an example of a stacked semiconductor package in accordance with an embodiment.

[0011] FIG. 4 is a cross-sectional view illustrating a representation of an example of a stacked semiconductor package in accordance with an embodiment.

[0012] FIG. 5 is a block diagram illustrating a representation of an example of an electronic system to which the semiconductor packages in accordance with the various embodiments may be applied.

[0013] FIG. 6 is a block diagram illustrating a representation of an example of a memory card which may include the semiconductor packages in accordance with the various embodiments.

DETAILED DESCRIPTION

[0014] Hereinafter, a stacked semiconductor package having mold vias and a method for manufacturing the same will

be described below with reference to the accompanying drawings through various examples of embodiments.

[0015] Embodiments provide a stacked semiconductor package having mold vias and a method for manufacturing the same.

[0016] Referring to FIG. 1, a stacked semiconductor package 100 in accordance with an embodiment may include a first semiconductor chip 10, a first encapsulation member 20, second semiconductor chips 30, first coupling members 40, a second encapsulation member 50, mold vias 60, second coupling members 70, and a substrate 80. The stacked semiconductor package 100 may further include bump pads 62, dummy pads 64, and support members 72. The stacked semiconductor package 100 may further include a third encapsulation member 90 and external coupling members 92.

[0017] The first semiconductor chip 10 may be either a memory chip or a logic chip. For example, the first semiconductor chip 10 may be a logic chip. The first semiconductor chip 10 may have a quadrangular plate shape. The first semiconductor chip 10 may have a first active surface 10a and a first surface 10b which faces away from the first active surface 10a. The first semiconductor chip 10 may include a plurality of first bonding pads 12 which are arranged in the form of a matrix on the first active surface 10a.

[0018] The first bonding pads 12 may be disposed in the first active surface 10a. Unlike this, the first bonding pads 12 may be disposed on the first active surface 10a. When viewed in a first direction X, the first bonding pads 12 may be divided into peripheral bonding pads 12a which are disposed at both side peripheries of the first active surface 10a and central bonding pads 12b which are disposed between the peripheral bonding pads 12a of the first active surface 10a. In an embodiment, the peripheral bonding pads 12a may be arranged in three lines at each side periphery of the first active surface 10a, and the central bonding pads 12b may be arranged in five lines between the peripheral bonding pads 12a disposed at both side peripheries of the first active surface 10a.

[0019] The first semiconductor chip 10 may be disposed in a face-down type such that the first active surface 10a on which the first bonding pads 12 are arranged faces downward.

[0020] While not shown, it may be understood that the first semiconductor chip 10 is formed with a passivation layer on the first active surface 10a in such a way as to leave the first bonding pads 12 exposed.

[0021] The first encapsulation member 20 may be formed to cover first side surfaces 10c of the first semiconductor chip 10. The first encapsulation member 20 may be formed to not cover the first active surface 10a and the first surface 10b of the first semiconductor chip 10. A first front surface 20a of the first encapsulation member 20 may be disposed to be coplanar with the first active surface 10a of the first semiconductor chip 10, and a first back surface 20b of the first encapsulation member 20 may be disposed to be coplanar with the first surface 10b of the first semiconductor chip 10. The first encapsulation member 20 may be formed of an epoxy molding compound. While not shown, in other embodiments the first encapsulation member 20 may be formed in such a way as to not cover the first active surface 10a of the first semiconductor chip 10 and to cover the first surface 10b and the first side surfaces 10c of the first

semiconductor chip 10. According to this fact, the first surface 10b of the first semiconductor chip 10 may be protected from external circumstances by the first encapsulation member 20.

[0022] The second semiconductor chips 30 may be disposed under the first semiconductor chip 10 and the first encapsulation member 20 in a second direction Y. Two second semiconductor chips 30 may be disposed in this manner. Each of the second semiconductor chips 30 may have a quadrangular plate shape. Each of the second semiconductor chips 30 may have a second active surface 30a and a second surface 30b which faces away from the second active surface 30a. Each of the second semiconductor chips 30 may include a plurality of second bonding pads 32 which are arranged on the second active surface 30a.

[0023] In each of the second semiconductor chips 30, the second bonding pads 32 may be disposed at one side periphery which is adjacent to the first semiconductor chip 10 when viewed in the first direction X. For example, in the second semiconductor chip 30 which is disposed at the lower left of the first semiconductor chip 10, the second bonding pads 32 may be disposed at the right side periphery of the second active surface 30a, and in the second semiconductor chip 30 which is disposed at the lower right of the first semiconductor chip 10, the second bonding pads 32 may be disposed at the left side periphery of the second active surface 30a.

[0024] The second semiconductor chips 30 may be disposed in a face-up type under the first semiconductor chip 10 and the first encapsulation member 20 such that the second active surfaces 30a of the second semiconductor chips 30 face the first active surface 10a of the first semiconductor chip 10. The second semiconductor chips 30 may be disposed to be separated from each other such that the second semiconductor chips 30 overlap with the peripheral bonding pads 12a of the first semiconductor chip 10 and leave exposed the central bonding pads 12b of the first semiconductor chip 10. The peripheral bonding pads 12a of the first semiconductor chip 10 and the second bonding pads 32 of the second semiconductor chips 30 may overlap with each other in a one-to-one correspondence.

[0025] The second semiconductor chips 30 may be a kind of chip that is different from the first semiconductor chip 10. For example, if the first semiconductor chip 10 is a logic chip, the second semiconductor chips 30 may be memory chips. While not shown, it may be understood that each of the second semiconductor chips 30 is formed with a passivation layer on the second active surface 30a in such a way as to leave the second bonding pads 32 exposed. The second bonding pads 32 may be disposed in the second active surfaces 30a as illustrated. Unlike this, while not shown, in other embodiments the second bonding pads 32 may be disposed on the second active surfaces 30a.

[0026] The first coupling members 40 may be respectively interposed between the peripheral bonding pads 12a of the first semiconductor chip 10 and the second bonding pads 32 of the second semiconductor chips 30 in such a way as to electrically couple the peripheral bonding pads 12a and the second bonding pads 32, which are disposed to overlap with each other. The first coupling members 40 may be constructed by bumps. The first coupling members 40 may be formed on the second bonding pads 32 of the second semiconductor chips 30. The second semiconductor chips 30

may be flip-chip bonded to the first active surface **10a** of the first semiconductor chip **10** by the first coupling members **40**.

[0027] The second encapsulation member **50** may be formed to cover the second active surfaces **30a** and second side surfaces **30c** of the second semiconductor chips **30**. The second encapsulation member **50** may be formed to not cover the second surfaces **30b** of the second semiconductor chips **30**. The second encapsulation member **50** may be formed to fill the region between the second semiconductor chips **30**. A second front surface **50a** of the second encapsulation member **50** may be disposed to be in contact with the first active surface **10a** of the first semiconductor chip **10** and the first front surface **20a** of the first encapsulation member **20**, and a second back surface **50b** of the second encapsulation member **50** may be disposed to be coplanar with the second surfaces **30b** of the second semiconductor chips **30**. The second encapsulation member **50** may be formed of an epoxy molding compound in the same manner as the first encapsulation member **20**. The total width of the second encapsulation member **50** and the second semiconductor chips **30** may be substantially the same as the total width of the first semiconductor chip **10** and the first encapsulation member **20**.

[0028] The mold vias **60** may be formed to electrically couple the first semiconductor chip **10** and the substrate **80**. The mold vias **60** may be formed through a portion of the second encapsulation member **50** between the second semiconductor chips **30**. The mold vias **60** may be formed to pass through the second front surface **50a** and the second back surface **50b** of the second encapsulation member **50**. The mold vias **60** may be coupled with the central bonding pads **12b** of the first semiconductor chip **10** on the second front surface **50a** of the second encapsulation member **50**. The mold vias **60** may be formed as through holes are formed in the second encapsulation member **50** and then a conductive layer such as a metal layer is filled in the through holes.

[0029] In the embodiment, the bump pads **62** may be formed on or under the portions of the mold vias **60** which are disposed at the second back surface **50b** of the second encapsulation member **50**. The dummy pads **64** may be formed under and at the side peripheries of the second surfaces **30b** of the second semiconductor chips **30** which are not adjacent to the mold vias **60** when viewed in the first direction X. The bump pads **62** and the dummy pads **64** may be formed as a metal pattern.

[0030] The second coupling members **70** may be formed on or under the bump pads **62**. The support members **72** may be formed on or under the dummy pads **64**. The second coupling members **70** and the support members **72** may be constructed by bumps. By the second coupling members **70**, a chip stack including the first semiconductor chip **10**, the first encapsulation member **20**, the second semiconductor chips **30**, and the second encapsulation member **50** may be flip-chip bonded to a top surface **80a** of the substrate **80**. The stack of the dummy pads **64** and the support members **72** may be formed to secure structural stability when flip-chip bonding the chip stack, and may be disposed at the side peripheries of the second surfaces **30b** of the second semiconductor chips **30** which are not adjacent to the mold vias **60** when viewed in the first direction X.

[0031] The substrate **80** may be disposed under the second semiconductor chips **30** and the second encapsulation member **50**. The substrate **80** may be disposed to face the second

surfaces **30b** of the second semiconductor chips **30** and the second back surface **50b** of the second encapsulation member **50**. The substrate **80** may be a printed circuit board, and have a quadrangular plate shape. The substrate **80** may have a size larger than the total size of the second semiconductor chips **30** and the second encapsulation member **50**. The substrate **80** may have the top surface **80a** and a bottom surface **80b** which faces away from the top surface **80a**. The substrate **80** may include a plurality of bond fingers **82** which are arranged on the top surface **80a** and a plurality of electrode terminals **84** which are arranged on or under the bottom surface **80b**.

[0032] The bond fingers **82** may be disposed at the center portion of the top surface **80a** of the substrate **80**. The bond fingers **82** may be disposed in such a way as to overlap with the mold vias **60** corresponding thereto. Accordingly, the bond fingers **82** may be electrically coupled with the mold vias **60** including the bump pads **62** by the second coupling members **70**. As a result, the bond fingers **82** may be electrically coupled with the central bonding pads **12b** of the first semiconductor chip **10** through the second coupling members **70**, the bump pads **62**, and the mold vias **60**.

[0033] The electrode terminals **84** may be arranged, for example, in the form of a matrix, on or under the bottom surface **80b** of the substrate **80**. The electrode terminals **84** may be coupled with internal wiring lines (not shown) which are formed in the substrate **80**, and may be electrically coupled with the bond fingers **82** which are arranged on the top surface **80a** of the substrate **80**, through the internal wiring lines.

[0034] The third encapsulation member **90** may be formed on or over the top surface **80a** of the substrate **80**. More clearly, the third encapsulation member **90** may be formed to not cover the first back surface **20b** of the first encapsulation member **20** and the first surface **10b** of the first semiconductor chip **10**. The third encapsulation member **90** may be formed to cover the side surfaces of the first encapsulation member **20** and the second encapsulation member **50**. The third encapsulation member **90** may be formed to fill the spaces between the second semiconductor chips **30** and the top surface **80a** of the substrate **80**. The third encapsulation member **90** may be formed of an epoxy molding compound. While not shown, in other embodiments the third encapsulation member **90** may be formed to cover the first surface **10b** of the first semiconductor chip **10** and the first back surface **20b** of the first encapsulation member **20**.

[0035] The external coupling members **92** may be formed on or under the electrode terminals **84** which are arranged on the bottom surface **80b** of the substrate **80**. The external coupling members **92** may include solder balls. Unlike this, the external coupling members **92** may include conductive pins or conductive pastes. The stacked semiconductor package **100** in accordance with the embodiment may be mounted to an external circuit such as a system board by the medium of the external coupling members **92**.

[0036] The stacked semiconductor package **100** in accordance with the embodiment as mentioned above may be manufactured through the following processes.

[0037] Referring to FIG. 2A, a carrier wafer **200** is prepared. The carrier wafer **200** may be an unprocessed silicon bare wafer. First semiconductor chips **10** having first active surfaces **10a** are attached to the carrier wafer **200**. Each of semiconductor chips are formed with first bonding pads **12**

on the first active surface **10a**. The first semiconductor chips **10** may be attached on or over the carrier wafer **200** such that the first active surfaces **10a** face the carrier wafer **200**. Further, the first semiconductor chips **10** are attached at intervals that are determined in consideration of second semiconductor chips to be subsequently flip-chip bonded.

[0038] Each of the first semiconductor chips **10** has the first active surface **10a** which is formed with the plurality of first bonding pads **12**, a first surface **10b** which faces away from the first active surface **10a**, and first side surfaces **10c** which couple the first active surface **10a** and the first surface **10b**. The first bonding pads **12** include peripheral bonding pads **12a** which are disposed at both side peripheries of the first active surface **10a** and central bonding pads **12b** which are disposed between the peripheral bonding pads **12a**.

[0039] Referring to FIG. 2B, a first encapsulation member **20** is formed on the carrier wafer **200** through a molding process in such a way as to cover the first semiconductor chips **10**. The first encapsulation member **20** may be an epoxy molding compound, and is formed to cover the first side surfaces **10c** and the first surface **10b** of each first semiconductor chip **10**. The first encapsulation member **20** has a first front surface **20a** which is coplanar with the first active surface **10a** of each first semiconductor chip **10**. Further, the first encapsulation member **20** may be formed over and may be in contact with the carrier wafer **200**. The first encapsulation member **20** has a first back surface **20b** which faces away from the first front surface **20a**.

[0040] Here, a resultant product in which the plurality of first semiconductor chips **10** are redispersed by the first encapsulation member **20** is referred to as a reconfigured wafer **250**.

[0041] Referring to FIG. 2C, the carrier wafer **200** is removed from the reconfigured wafer **250** including the first semiconductor chips **10** and the first encapsulation member **20**. Then, the reconfigured wafer **250** from which the carrier wafer **200** is removed is disposed upside down such that the first active surfaces **10a** of the first semiconductor chips **10** are positioned up.

[0042] Referring to FIG. 2D, second semiconductor chips **30** are prepared. Each of the second semiconductor chips have a second active surface **30a** on or over which a plurality of second bonding pads **32** are arranged, a second surface **30b** which faces away from the second active surface **30a** and second side surfaces **30c** which couple the second active surface **30a** and the second surface **30b**. The second bonding pads **32** may be arranged at one side periphery of the second active surface **30a** which is adjacent to the first semiconductor chips **10**. First coupling members **40** are formed on the second bonding pads **32** of the second semiconductor chips **30**. The first coupling members **40** may be constructed by bumps. In an embodiment, in order to ensure easy handling, the second semiconductor chips **30** have a thickness greater than a target thickness t , that is, a thickness of the second semiconductor chips **30** in a final stacked semiconductor package.

[0043] The second semiconductor chips **30** are flip-chip bonded to the reconfigured wafer **250** by the first coupling members **40** according to a wafer level package technology such that the first active surfaces **10a** of the first semiconductor chips **10** and the second active surfaces **30a** of the second semiconductor chips **30** face each other. More clearly, two second semiconductor chips **30** are flip-chip bonded to one first semiconductor chip **10** by the first

coupling members **40** such that the two second semiconductor chips **30** overlap with the peripheral bonding pads **12a** of the first active surface **10a** with respect to the one first semiconductor chip **10**. Accordingly, the peripheral bonding pads **12a** of the first semiconductor chips **10** and the second bonding pads **32** of the second semiconductor chips **30** are electrically coupled with each other by the first coupling members **40**, and the central bonding pads **12b** of the first semiconductor chips **10** are exposed through the regions between two second semiconductor chips **30**.

[0044] Referring to FIG. 2E, a second encapsulation member **50** is formed on or over the reconfigured wafer **250** to cover the second semiconductor chips **30**. The second encapsulation member **50** may be an epoxy molding compound. The second encapsulation member **50** is formed to fill the spaces between the first semiconductor chips **10** and the second semiconductor chips **30** and the spaces between the first encapsulation member **20** and the second semiconductor chips **30**, and is formed to fill the regions between the second semiconductor chips **30**. The second encapsulation member **50** has a second front surface **50a** which is in contact with the first encapsulation member **20** and a second back surface **50b** which faces away from the second front surface **50a**.

[0045] Referring to FIG. 2F, the second encapsulation member **50** and the second semiconductor chips **30** are partially removed up to the target thickness t of the second semiconductor chips **30**. The partial removal of the second encapsulation member **50** and the second semiconductor chips **30** may be performed through, for example, a grinding process. In FIG. 2F, the second back surface **50b** of the final second encapsulation member **50** and the second surfaces **30b** of the final second semiconductor chips **30** are the exposed surfaces with some thickness removed, respectively. While not shown, after partially removing the second encapsulation member **50** and the second semiconductor chips **30**, the partial removal of the first back surface **20b** of the first encapsulation member **20** may be performed such that the first surfaces **10a** of the first semiconductor chips **10** are exposed.

[0046] Referring to FIG. 2G, portions of the second encapsulation member **50** between the second semiconductor chips **30** are etched such that holes h which respectively expose the central bonding pads **12b** of the first semiconductor chips **10** are formed. As a conductive layer such as a metal layer is filled in the holes h , mold vias **60** are formed in the holes h , respectively. The mold vias **60** are formed to pass through the second front surface **50a** and the second back surface **50b** of the second encapsulation member **50** in a region between the second semiconductor chips **30**, and are electrically coupled with the central bonding pads **12b**, respectively, of the first semiconductor chips **10**.

[0047] Referring to FIG. 2H, bump pads **62** are formed on or over the mold vias **60** which are disposed at the second back surface **50b** of the second encapsulation member **50**, and, at the same time, dummy pads **64** are formed on or over the second back surfaces **30b** of the second semiconductor chips **30**. The bump pads **62** and the dummy pads **64** may be formed of a metal. Second coupling members **70** are formed on or over the bump pads **62**, and, at the same time, support members **72** are formed on or over the dummy pads **64**. The second coupling members **70** and the support members **72** may be constructed by, for example, bumps.

[0048] In the embodiment, the dummy pads 64 and the support members 72 may be formed to secure structural stability when subsequently flip-chip bonding chip stacks by the medium of the second coupling members 70. The dummy pads 64 and the support members 72 may be disposed at the side peripheries of the second surfaces 30b of the second semiconductor chips 30 which are not adjacent to the mold vias 60.

[0049] Referring to FIG. 2I, A resultant product with the dummy pads 64 and support members 72 is sawed such that the resultant product is separated into a plurality of chip stacks. The chip stacks include the first and second semiconductor chips 10 and 30, the first and second encapsulation members 20 and 50, and the mold vias 60, respectively.

[0050] A substrate 80 is prepared. The substrate 80 has a top surface 80a on which a plurality of bond fingers 82 are arranged and a bottom surface 80b which faces away from the top surface 80a and on which a plurality of electrode terminals 84 are arranged. The chip stacks are flip-chip bonded to the top surface 80a of the substrate 80 such that the top surface 80a of the substrate 80 and the second surfaces 30b of the second semiconductor chips 30 face each other. Here, the chip stacks are bonded such that the second coupling members 70 are coupled with the bond fingers 82 of the substrate 80 by the medium of the mold vias 60, the bump pads 62 and the second coupling members 70. When flip-chip bonding the chip stacks, the support members 72 including the dummy pads 64 are brought into contact with both side peripheries of the top surface 80a of the substrate 80, and accordingly, the structural stability of the chip stacks is secured.

[0051] A third encapsulation member 90 is formed through a molding process on or over the substrate 80 such that the chip stacks are completely covered. The third encapsulation member 90 may be formed to cover the side surfaces of the first encapsulation member 20 and the second encapsulation member 50 and fill the spaces between the second semiconductor chips 30 and the substrate 80. The third encapsulation member 90 may be formed of an epoxy molding compound.

[0052] Referring to FIG. 2J, the third encapsulation member 90 and the first back surface 20b of the first encapsulation member 20 are partially removed such that the first surfaces 10b of the first semiconductor chips 10 are exposed. The partial removal of the third encapsulation member 90 and the first encapsulation member 20 may be performed through, for example, a grinding process. Here, the first back surface 20b of the final first encapsulation member 20 is the exposed surface with some thickness removed. External coupling members 92 are formed on the electrode terminals 84, respectively, which are arranged on or under the bottom surface 80b of the substrate 80. The external coupling members 92 may be solder balls. A singulation process is performed for a resultant product in which the external coupling members 92 are formed in such a manner that the packages which are manufactured at a wafer level are separated into individual packages. As a result, the manufacturing of a stacked semiconductor package 100 in accordance with the embodiment is completed.

[0053] The stacked semiconductor package 100 in accordance with the embodiment as mentioned above has advan-

tages in that it is possible to reduce the manufacturing cost and simplify the manufacturing process.

[0054] In detail, in the conventional art, a silicon interposer is needed to implement a planar type stacked package, and TSVs (through-silicon vias) are needed to implement a vertical type stacked package. If a silicon interposer is applied, an increase in the manufacturing cost cannot help but be caused due to the presence of the silicon interposer, and a burden is imposed in terms of signal routing. Similarly, even in the case where TSVs are applied, a burden is imposed due to a complicated process and an increase in the manufacturing cost cannot help but be caused.

[0055] However, in the case of the stacked semiconductor package 100 in accordance with the embodiment, second semiconductor chips may be stacked in a planar type without the need of applying a silicon interposer, and a first semiconductor chip and second semiconductor chips may be stacked in a vertical type without the need of applying TSVs. As a consequence, in the stacked semiconductor package 100 in accordance with the embodiment, an increase in the manufacturing cost attributable to application of a silicon interposer and TSVs may be avoided, and a burden in process due to signal routing and forming of complicated TSVs may be avoided.

[0056] Therefore, the stacked semiconductor package 100 in accordance with the embodiment may overcome commercial and technical limitations in comparison with the conventional art in which a silicon interposer, signal routing, and TSVs should be applied.

[0057] Referring to FIG. 3, a stacked semiconductor package 300 in accordance with an embodiment may include a first semiconductor chip 10, a first encapsulation member 20, second semiconductor chips 30, first coupling members 40, a second encapsulation member 50, mold vias 60, second coupling members 70, a substrate 80, and an underfill 95. The stacked semiconductor package 300 may further include external coupling members 92.

[0058] The first semiconductor chip 10 may be either a memory chip or a logic chip. For example, the first semiconductor chip 10 may be a logic chip. The first semiconductor chip 10 may have a first active surface 10a and a first surface 10b which faces away from the first active surface 10a. The first semiconductor chip 10 may include a plurality of first bonding pads 12 which are arranged on the first active surface 10a. When viewed in a first direction X, the first bonding pads 12 may include peripheral bonding pads 12a which are disposed at both side peripheries of the first active surface 10a and central bonding pads 12b which are disposed between the peripheral bonding pads 12a of the first active surface 10a. The first semiconductor chip 10 may be disposed in a face-down type such that the first active surface 10a on which the first bonding pads 12 are arranged faces downward.

[0059] The first encapsulation member 20 may be formed to cover first side surfaces 10c of the first semiconductor chip 10. The first encapsulation member 20 may be formed to not cover the first active surface 10a and the first surface 10b of the first semiconductor chip 10. The first encapsulation member 20 may be formed of an epoxy molding compound.

[0060] Two second semiconductor chips 30 may be disposed under the first semiconductor chip 10 and the first encapsulation member 20 in a second direction Y. Each of the second semiconductor chips 30 may have a second

active surface **30a** and a second surface **30b** which faces away from the second active surface **30a**. The second semiconductor chips **30** may be disposed such that the second active surfaces **30a** of the second semiconductor chips **30** face the first active surface **10a** of the first semiconductor chip **10**. Each of the second semiconductor chips **30** may include a plurality of second bonding pads **32** which are arranged on the second active surface **30a**. The second bonding pads **32** of each of the second semiconductor chips **30** may be disposed at one side periphery of the second active surface **30a** which is adjacent to the first semiconductor chip **10** when viewed in the first direction X.

[0061] The two second semiconductor chips **30** may be disposed to be separated from each other in such a manner that the side peripheries of the second active surfaces **30a** at which the second bonding pads **32** are arranged overlap with the peripheral bonding pads **12a** of the first semiconductor chip **10** leaving the central bonding pads **12b** of the first semiconductor chip **10** exposed. The second bonding pads **32** of the second semiconductor chips **30** may be disposed to overlap with the peripheral bonding pads **12a** of the first semiconductor chip **10** in a one-to-one correspondence.

[0062] The second semiconductor chips **30** may be a kind of chip that is different from the first semiconductor chip **10**. For example, if the first semiconductor chip **10** is a logic chip, the second semiconductor chips **30** may be memory chips.

[0063] The first coupling members **40** may be interposed between the peripheral bonding pads **12a** of the first semiconductor chip **10** and the second bonding pads **32** of the second semiconductor chips **30**. The first coupling members **40** may be constructed by bumps. The first coupling members **40** may be formed on the second bonding pads **32** of the second semiconductor chips **30**. The second semiconductor chips **30** may be flip-chip bonded to the first active surface **10a** of the first semiconductor chip **10** by the first coupling members **40**.

[0064] The second encapsulation member **50** may be formed to cover the second active surfaces **30a** and second side surfaces **30c** of the second semiconductor chips **30**. The second encapsulation member **50** may be formed to not cover the second surfaces **30b** of the second semiconductor chips **30**. The second encapsulation member **50** may be formed to fill the region between the second semiconductor chips **30**. The second encapsulation member **50** may be formed of an epoxy molding compound.

[0065] The mold vias **60** may be formed through a portion of the second encapsulation member **50** between the second semiconductor chips **30**. The mold vias **60** may be formed to pass through a second front surface **50a** and a second back surface **50b** of the second encapsulation member **50**. The mold vias **60** may be coupled with the central bonding pads **12b**, respectively, of the first semiconductor chip **10** on the second front surface **50a** of the second encapsulation member **50**.

[0066] Bump pads **62** may be formed on or under the portions of the mold vias **60** which are disposed at the second back surface **50b** of the second encapsulation member **50**. Dummy pads **64** may be formed under and at the side peripheries of the second surfaces **30b** of the second semiconductor chips **30** which are not adjacent to the mold vias **60** when viewed in the first direction X. The bump pads **62** and the dummy pads **64** may be formed as a metal pattern.

[0067] The second coupling members **70** may be formed on or under the bump pads **62**. Support members **72** may be formed on or under the dummy pads **64**. The second coupling members **70** and the support members **72** may be constructed by bumps. By the second coupling members **70**, a chip stack including the first semiconductor chip **10**, the first encapsulation member **20**, the second semiconductor chips **30**, and the second encapsulation member **50** may be flip-chip bonded to a top surface **80a** of the substrate **80**. The stack of the dummy pads **64** and the support members **72** may be formed to secure structural stability when flip-chip bonding the chip stack. The stack of the dummy pads **64** and the support members **72** may be disposed at the side peripheries of the second surfaces **30b** of the second semiconductor chips **30** which are not adjacent to the mold vias **60** when viewed in the first direction X.

[0068] The substrate **80** may be disposed under the second semiconductor chips **30** and the second encapsulation member **50**. That is, the substrate **80** may be disposed to face the second surfaces **30b** of the second semiconductor chips **30** and the second back surface **50b** of the second encapsulation member **50**. The substrate **80** may be a printed circuit board, and have a quadrangular plate shape. The substrate **80** may have the top surface **80a** and a bottom surface **80b** which faces away from the top surface **80a**. The substrate **80** may include a plurality of bond fingers **82** which are arranged on the top surface **80a** and a plurality of electrode terminals **84** which are arranged on or under the bottom surface **80b**.

[0069] The bond fingers **82** may be disposed at the center portion of the top surface **80a** of the substrate **80**. The bond fingers **82** may be disposed in such a way as to overlap with the mold vias **60** corresponding thereto. Accordingly, the bond fingers **82** may be electrically coupled with the mold vias **60** including the bump pads **62** by the second coupling members **70**. As a result, the bond fingers **82** may be electrically coupled with the central bonding pads **12b** of the first semiconductor chip **10** through the second coupling members **70**, the bump pads **62**, and the mold vias **60**.

[0070] The electrode terminals **84** may be arranged on or under the bottom surface **80b** of the substrate **80**. The electrode terminals **84** may be electrically coupled with the bond fingers **82** which are arranged on the top surface **80a** of the substrate **80**, through internal wiring lines (not shown) which are formed in the substrate **80**.

[0071] The underfill **95** may be formed to fill the space between the chip stack and the substrate **80**. More clearly, the underfill **95** may be formed to fill the spaces between the second surfaces **30b** of the second semiconductor chips **30** on which the stacks of the bump pads **62** and the second coupling members **70** and the stacks of the dummy pads **64** and the support members **72** are disposed, and the second back surface **50b** of the second encapsulation member **50** and the top surface **80a** of the substrate **80**. The underfill **95** may include an epoxy constituent.

[0072] The external coupling members **92** may be formed on or under the electrode terminals **84** which are arranged on the bottom surface **80b** of the substrate **80**. The external coupling members **92** may include solder balls. Unlike this, the external coupling members **92** may include conductive pins or conductive pastes.

[0073] Referring to FIG. 4, a stacked semiconductor package **400** in accordance with an embodiment may include a first semiconductor chip **10**, a first encapsulation member **20**, second semiconductor chips **30**, first coupling members

40, a second encapsulation member 50, mold vias 60, and a redistribution layer 110. The stacked semiconductor package 400 may further include external coupling members 120.

[0074] The first semiconductor chip 10 may be either a memory chip or a logic chip. For example, the first semiconductor chip 10 may be a logic chip. The first semiconductor chip 10 may have a first active surface 10a and a first surface 10b which faces away from the first active surface 10a. The first semiconductor chip 10 may include a plurality of first bonding pads 12 which are arranged on the first active surface 10a. When viewed in a first direction X, the first bonding pads 12 may include peripheral bonding pads 12a which are disposed at both side peripheries of the first active surface 10a and central bonding pads 12b which are disposed between the peripheral bonding pads 12a. The first semiconductor chip 10 may be disposed in a face-down type such that the first active surface 10a on which the first bonding pads 12 are arranged faces downward.

[0075] The first encapsulation member 20 may be formed to cover first side surfaces 10c of the first semiconductor chip 10. The first encapsulation member 20 may be formed to not cover the first active surface 10a and the first surface 10b of the first semiconductor chip 10. The first encapsulation member 20 may be formed of an epoxy molding compound.

[0076] The second semiconductor chips 30 may be disposed under the first semiconductor chip 10 and the first encapsulation member 20 in a second direction Y. Two second semiconductor chips 30 may be disposed. Each of the second semiconductor chips 30 may have a second active surface 30a and a second surface 30b which faces away from the second active surface 30a. Each of the second semiconductor chips 30 may include a plurality of second bonding pads 32 which are arranged on the second active surface 30a. The second bonding pads 32 of each of the second semiconductor chips 30 may be disposed at one side periphery of the second active surface 30a which is adjacent to the first semiconductor chip 10 when viewed in the first direction X.

[0077] The second semiconductor chips 30 may be disposed such that the second active surfaces 30a of the second semiconductor chips 30 face the first active surface 10a of the first semiconductor chip 10. The two second semiconductor chips 30 may be disposed to be separated from each other in such a manner that the side peripheries of the second active surfaces 30a at which the second bonding pads 32 are arranged overlap with the peripheral bonding pads 12a of the first semiconductor chip 10. The two second semiconductor chips 30 may be disposed to not overlap with the central bonding pads 12b of the first semiconductor chip 10. The peripheral bonding pads 12a of the first semiconductor chip 10 and the second bonding pads 32 of the second semiconductor chips 30 may be disposed to overlap with each other in a one-to-one correspondence.

[0078] The second semiconductor chips 30 may be a kind of chip that is different from the first semiconductor chip 10. For example, if the first semiconductor chip 10 is a logic chip, the second semiconductor chips 30 may be memory chips.

[0079] The first coupling members 40 may be respectively interposed between the peripheral bonding pads 12a of the first semiconductor chip 10 and the second bonding pads 32 of the second semiconductor chips 30 in such a way as to electrically couple the peripheral bonding pads 12a and the

second bonding pads 32. The first coupling members 40 may be constructed by bumps. The first coupling members 40 may be formed on the second bonding pads 32 of the second semiconductor chips 30. The second semiconductor chips 30 may be flip-chip bonded to the first active surface 10a of the first semiconductor chip 10 by the first coupling members 40.

[0080] The second encapsulation member 50 may be formed to cover the second active surfaces 30a and second side surfaces 30c of the second semiconductor chips 30. The second encapsulation member 50 may be formed to not cover the second surfaces 30b of the second semiconductor chips 30. The second encapsulation member 50 may be formed to fill the region between the second semiconductor chips 30. The second encapsulation member 50 may be formed of an epoxy molding compound.

[0081] The mold vias 60 may be formed through portions of the second encapsulation member 50 between the second semiconductor chips 30 to pass through a second front surface 50a and a second back surface 50b of the second encapsulation member 50. The mold vias 60 may be coupled with the central bonding pads 12b, respectively, of the first semiconductor chip 10 on the second front surface 50a of the second encapsulation member 50.

[0082] The redistribution layer 110 may function as means for mounting a chip stack including the first and second semiconductor chips 10 and 30 to an external circuit. The redistribution layer 110 may include a first dielectric layer 112, redistribution lines 114, and a second dielectric layer 116. The redistribution layer 110 may further include redistribution pads 118. The redistribution layer 110 may be formed under the second surfaces 30b of the second semiconductor chips 30, the second back surface 50b of the second encapsulation member 50, and the mold vias 60.

[0083] The first dielectric layer 112 may be formed on or under the second surfaces 30b of the second semiconductor chips 30, the second back surface 50b of the second encapsulation member 50, and the mold vias 60. The first dielectric layer 112 may be formed under the second surfaces 30b of the second semiconductor chips 30 and the second back surface 50b. The first dielectric layer 112 may be formed to leave exposed portions of the mold vias 60 which are disposed on the second back surface 50b of the second encapsulation member 50. The first dielectric layer 112 may serve as a stress buffer. The redistribution lines 114 may be formed on or under the first dielectric layer 112. The redistribution lines 114 may be formed in such a manner that one ends of the respective redistribution lines 114 are coupled with the mold vias 60 which are exposed through the first dielectric layer 112. The redistribution lines 114 may be constructed by, for example, copper wiring lines. The second dielectric layer 116 may be formed on or under the first dielectric layer 112 to cover the redistribution lines 114. The second dielectric layer 116 may be formed to leave exposed the other ends of the redistribution lines 114 facing away from the one ends. The redistribution pads 118 may be formed on or under the second dielectric layer 116. The redistribution pads 118 may be formed in such a way as to be coupled with the other ends, respectively, of the redistribution lines 114 which are exposed through the second dielectric layer 116.

[0084] The external coupling members 120 may be formed on or under the redistribution pads 118, respectively. The external coupling members 120 may be constructed by

solder balls. Unlike this, the external coupling members **120** may be constructed by conductive pins or conductive pastes.

[0085] The stacked semiconductor package in accordance with the embodiment may have advantages the same as those of the embodiment illustrated in FIG. 1. In addition, because the stacked semiconductor package in accordance with the embodiment includes a redistribution layer instead of a substrate, an entire thickness may be reduced when compared to that of the embodiment illustrated in FIG. 1, and the manufacturing cost may be reduced through removal of the substrate.

[0086] The semiconductor packages in accordance with the above-described various embodiments may be applied to various kinds of electronic systems and memory cards.

[0087] Referring to FIG. 5, an electronic system **500** may include the stacked semiconductor package according to the above-described various embodiments. The electronic system **500** may include a controller **510**, an input and output (input/output) unit **520**, and a memory device **530**. The controller **510**, the input/output unit **520**, and the memory device **530** may be coupled with one another through a bus **550** which provides data movement paths.

[0088] For example, the controller **510** may include at least any one of a microprocessor, a digital signal processor, a microcontroller, and logic devices capable of performing similar functions to these components. The controller **510** and the memory device **530** may include the stacked semiconductor packages in accordance with the above-described various embodiments. The input/output unit **520** may include any one selected among a keypad, a keyboard, a display device, and so forth.

[0089] The memory device **530** may store data and/or commands to be executed by the controller **510**. The memory device **530** may include a volatile memory device such as a DRAM and/or a nonvolatile memory device such as a flash memory. For example, a flash memory may be mounted to an information processing system such as a mobile terminal and a desktop computer. Such a flash memory may be configured by an SSD (solid state drive). In this case, the electronic system **500** may stably store a large amount of data in a flash memory system.

[0090] Such an electronic system **500** may further include an interface **540** for transmitting data to a communication network or receiving data from a communication network. The interface **540** may be a wired or wireless type. For example, the interface **540** may include an antenna or a wired/wireless transceiver.

[0091] Although not illustrated, the electronic system **500** may further include an application chipset, a camera image processor (CIP), and so forth.

[0092] The electronic system **500** may be realized as a mobile system, a personal computer, a computer for an industrial use or a logic system which performs various functions. For example, the mobile system may be any one among a personal digital assistant (PDA), a portable computer, a web tablet, a mobile phone, a smart phone, a wireless phone, a laptop computer, a memory card, a digital music system and an information transmission/reception system.

[0093] In the case where the electronic system **500** is equipment capable of performing wireless communication, the electronic system **500** may be used in a communication system such as CDMA (code division multiple access), GSM (global system for mobile communication), NADC

(North American digital cellular), E-TDMA (enhanced-time division multiple access), WCDMA (wideband code division multiple access), CDMA2000, LTE (long term evolution), and Wibro (wireless broadband Internet).

[0094] Referring to FIG. 6, a memory card may include the stacked semiconductor packages according to the above-described various embodiments. For instance, a memory card **600** may include a memory **610** such as a nonvolatile memory device and a memory controller **620**. The memory **610** and the memory controller **620** may store data or read stored data. The memory **610** may include at least any one among nonvolatile memory devices to which the stacked semiconductor packages in accordance with the above-described various embodiments are applied. The memory controller **620** may control the memory **610** to read stored data or store data, in response to a read and write (read/write) request from a host **630**.

[0095] Although various embodiments have been described for illustrative purposes, it will be apparent to those skilled in the art that various changes and modifications may be made without departing from the spirit and scope of the disclosure as defined in the following claims.

What is claimed is:

1. A method for manufacturing a stacked semiconductor package, comprising:

disposing first semiconductor chips having first active surfaces over which first bonding pads including peripheral bonding pads and a central bonding pad are arranged, over a carrier wafer such that the carrier wafer and the first active surfaces face each other;

forming a first encapsulation member which covers the first semiconductor chips, over the carrier wafer such that a reconfigured wafer in which the first semiconductor chips are redispersed is constructed;

removing the carrier wafer from the reconfigured wafer;

bonding two second semiconductor chips to one first semiconductor chip on the reconfigured wafer at a distance from each other, wherein the second semiconductor chips have second active surfaces over which second bonding pads are arranged at side peripheries adjacent to the first semiconductor chip, wherein the second semiconductor chips have first coupling members formed on the second bonding pads, wherein the second semiconductor chips possess a thickness greater than a target thickness, and wherein the second semiconductor chips are disposed on the reconfigured wafer, such that the second active surfaces face the first active surface, the second bonding pads are coupled with the peripheral bonding pads by the first coupling members and the central bonding pad is exposed;

forming a second encapsulation member over the reconfigured wafer in such a way as to cover the second semiconductor chips;

removing a partial thickness of the second encapsulation member and the second semiconductor chips such that the target thickness of the second semiconductor chips remains; and

forming a mold via which is coupled with the central bonding pad of the first semiconductor chip, and which pass through a portion of the second encapsulation member in a region between the second semiconductor chips.

2. The method according to claim 1, further comprising, after the forming of the mold via:

forming a mold via which is coupled with the central bonding pad of the first semiconductor chip, and which pass through a portion of the second encapsulation member in a region between the second semiconductor chips.

2. The method according to claim 1, further comprising, after the forming of the mold via:

- forming a bump pad which is disposed over the mold via and dummy pads which are disposed over second surfaces of the second semiconductor chips; and forming a second coupling member over the bump pad, and forming support members over the dummy pads.
3. The method according to claim 2, further comprising, after the forming of the second coupling member and the support members:
- sawing a resultant product with the second coupling member and the support members such that the resultant product is separated into a plurality of chip stacks including the first and second semiconductor chips, the first and second encapsulation members and the mold via.
4. The method according to claim 3, further comprising, after the sawing of the resultant product:
- bonding the chip stacks to a top surface of a substrate having the top surface over which a bond finger is arranged and a bottom surface under which an electrode terminal is arranged, such that the second coupling member and the bond finger are coupled with each other;
 - forming a third encapsulation member over the substrate in such a way as to cover side surfaces of the first and second encapsulation members;
 - partially removing the third encapsulation member and the first back surface of the first encapsulation member such that the first surfaces of the first semiconductor chips are exposed; and
 - forming an external coupling member over the electrode terminal.
5. The method according to claim 4, further comprising, after the forming of the external coupling members:
- singulating a resultant product such that the resultant product is separated into individual packages.
6. The method according to claim 3, further comprising, after the sawing of the resultant product:
- bonding a chip stack to a top surface of a substrate having the top surface over which a bond finger is arranged and a bottom surface under which an electrode terminal is arranged, such that the second coupling member and the bond finger are coupled with each other;
 - forming an underfill to fill spaces between the second semiconductor chips and the second encapsulation member and the top surface of the substrate; and
 - forming an external coupling member over the electrode terminal.
7. The method according to claim 6, further comprising, after the forming of the external coupling members:
- singulating a resultant product such that the resultant product is separated into individual packages.
8. The method according to claim 3, further comprising, after the forming of the mold vias:
- forming a first dielectric layer under second surfaces of the second semiconductor chips facing away from the second active surfaces, and the second encapsulation member in such a way as to leave exposed the mold via;
 - forming, under the first dielectric layer, a redistribution line having one end which is coupled with the exposed mold via;
 - forming a second dielectric layer under the redistribution line and the first dielectric layer in such a way as to expose the other end of the redistribution line facing away from the one end; and
 - forming, under the second dielectric layer, a redistribution pad which is coupled with the exposed other end of the redistribution line.
9. The method according to claim 8, further comprising, after the forming of the redistribution pad:
- forming an external coupling member under the redistribution pad; and
 - singulating a resultant product such that the resultant product is separated into individual packages.

* * * * *