



US 20180368954A1

(19) **United States**

(12) **Patent Application Publication** (10) **Pub. No.: US 2018/0368954 A1**

Katzman et al.

(43) **Pub. Date: Dec. 27, 2018**

(54) **DENTAL IMPRESSION KIT AND METHODS THEREFOR**

Publication Classification

(71) Applicant: **SmileDirectClub LLC**, Nashville, TN (US)

(51) **Int. Cl.**
A61C 9/00 (2006.01)
A61C 19/02 (2006.01)

(72) Inventors: **Jordan Katzman**, Nashville, TN (US);
Alex Fenkell, Nashville, TN (US);
David Katzman, Nashville, TN (US);
Christopher Yancey, Nashville, TN (US);
Josh Chapman, Nashville, TN (US)

(52) **U.S. Cl.**
CPC *A61C 9/0006* (2013.01); *A61C 9/0026* (2013.01); *A61C 19/02* (2013.01)

(21) Appl. No.: **16/047,694**

(57) **ABSTRACT**

(22) Filed: **Jul. 27, 2018**

A dental impression kit includes a container including a dental assembly that includes a dental tray and a predetermined amount of base putty and catalyst putty, where the base putty and the catalyst putty are mixable to form a putty mixture, and the predetermined amount of base putty and catalyst putty are amounts sufficient such that the putty mixture can be positioned in the dental tray for creating a dental impression. The dental impression kit includes instructions instructing a user to administer the dental assembly to create the dental impression, where the dental impression provides information necessary to manufacture a plurality of dental aligners specific to the user and being configured to reposition one or more teeth of the user, and where the predetermined amounts of the base putty and the catalyst putty are in the range of 0.5 ounces and 1.5 ounces.

Related U.S. Application Data

(63) Continuation-in-part of application No. 15/725,430, filed on Oct. 5, 2017.

(60) Provisional application No. 62/648,229, filed on Mar. 26, 2018, provisional application No. 62/663,725, filed on Apr. 27, 2018, provisional application No. 62/522,847, filed on Jun. 21, 2017.

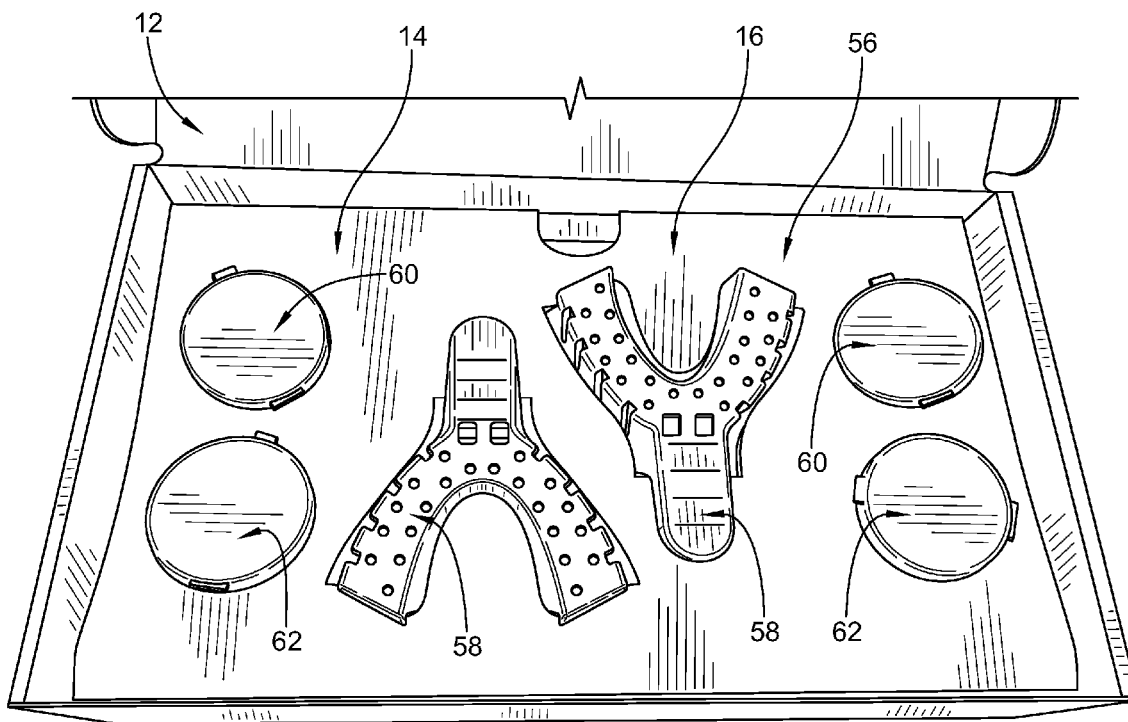

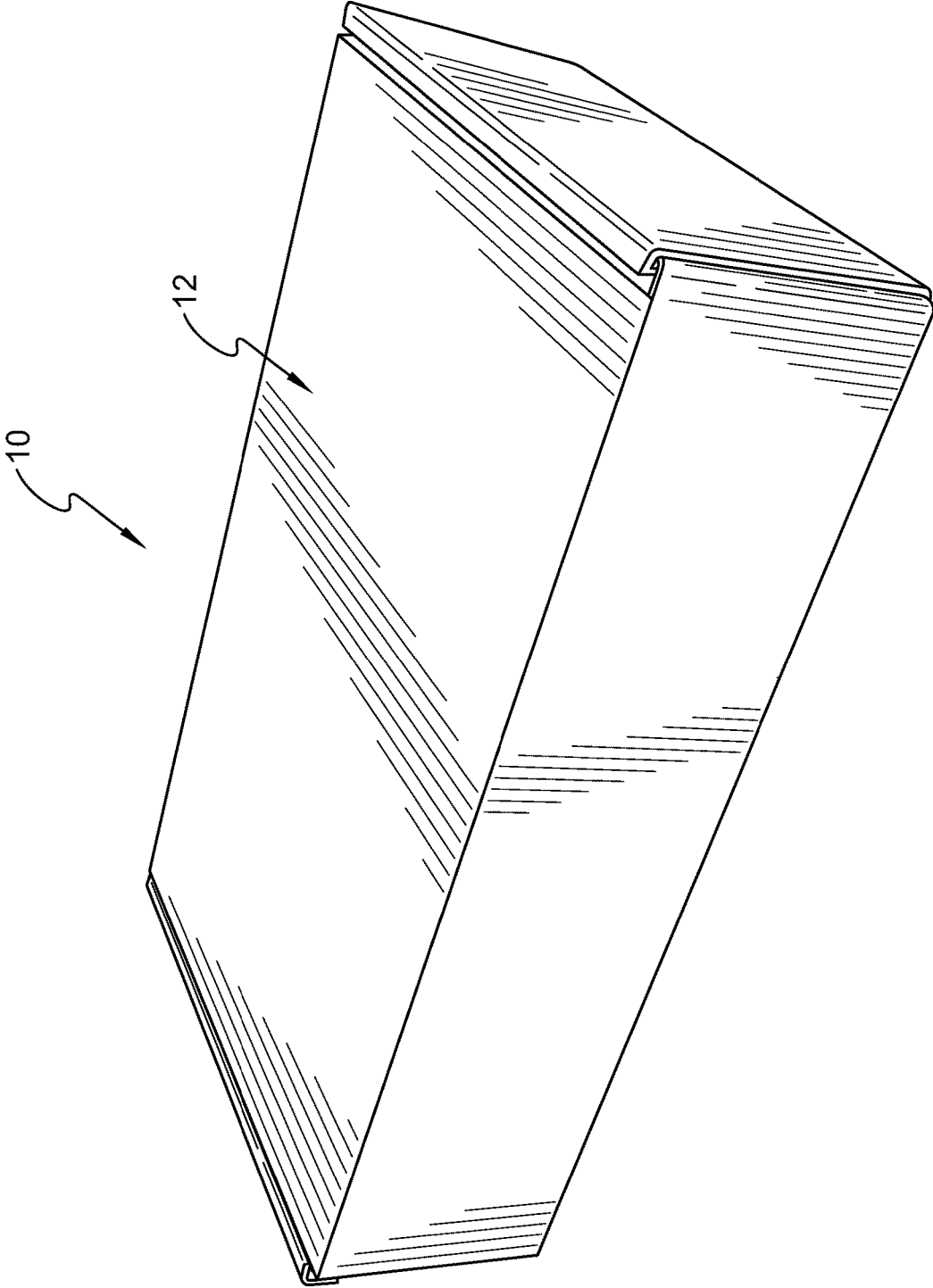

FIG. 1

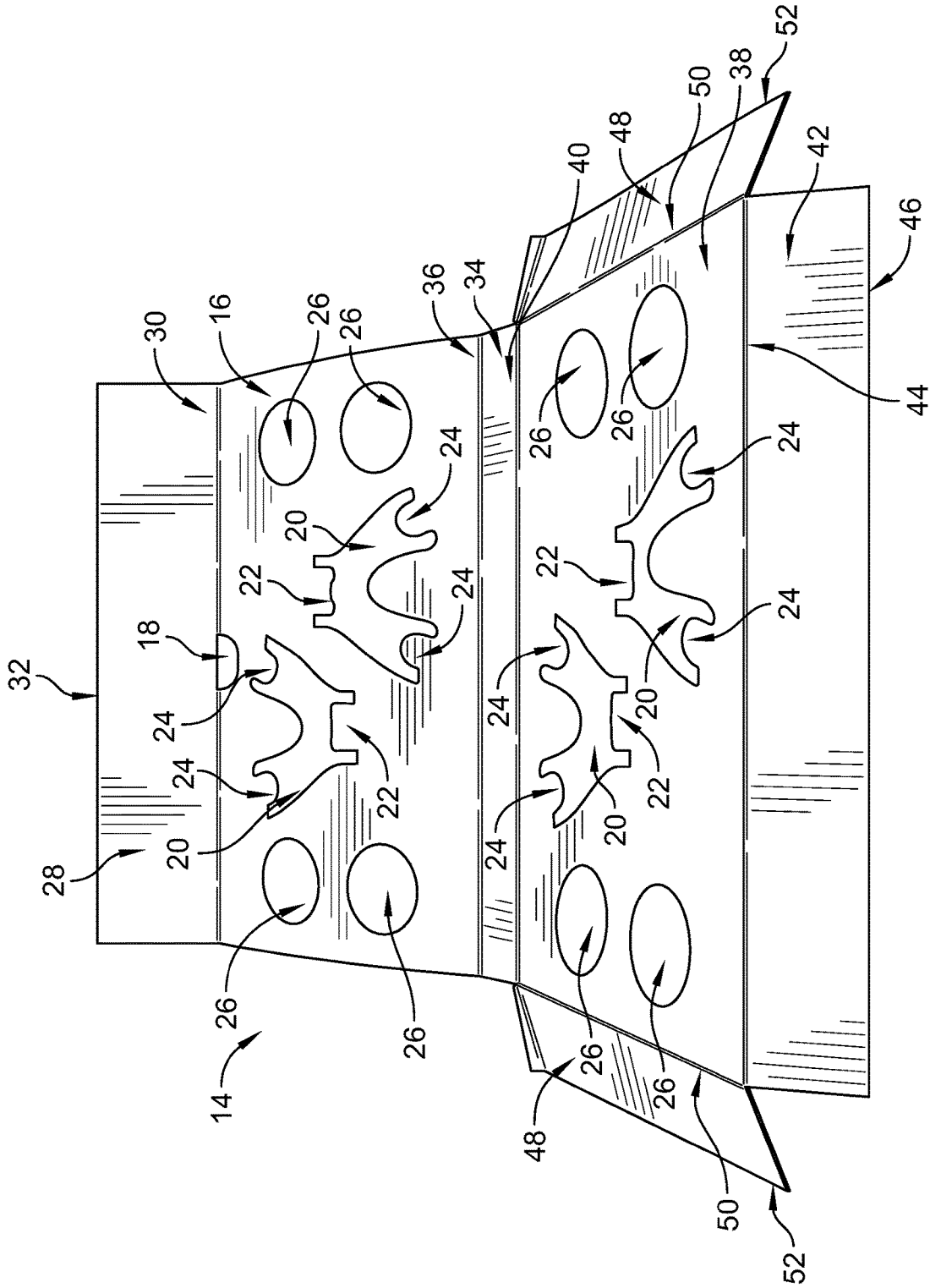

FIG. 2



FIG. 3

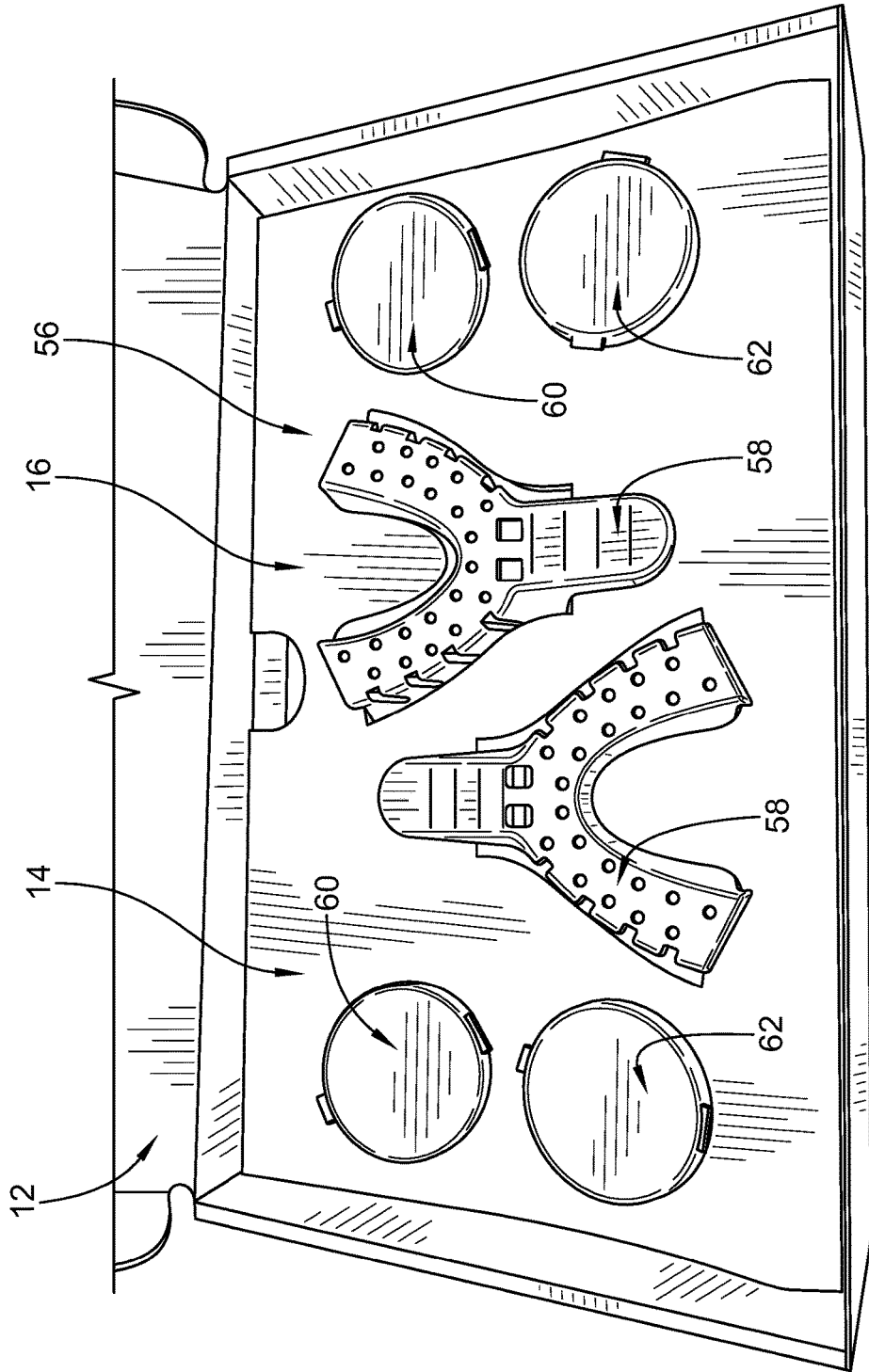

FIG. 4

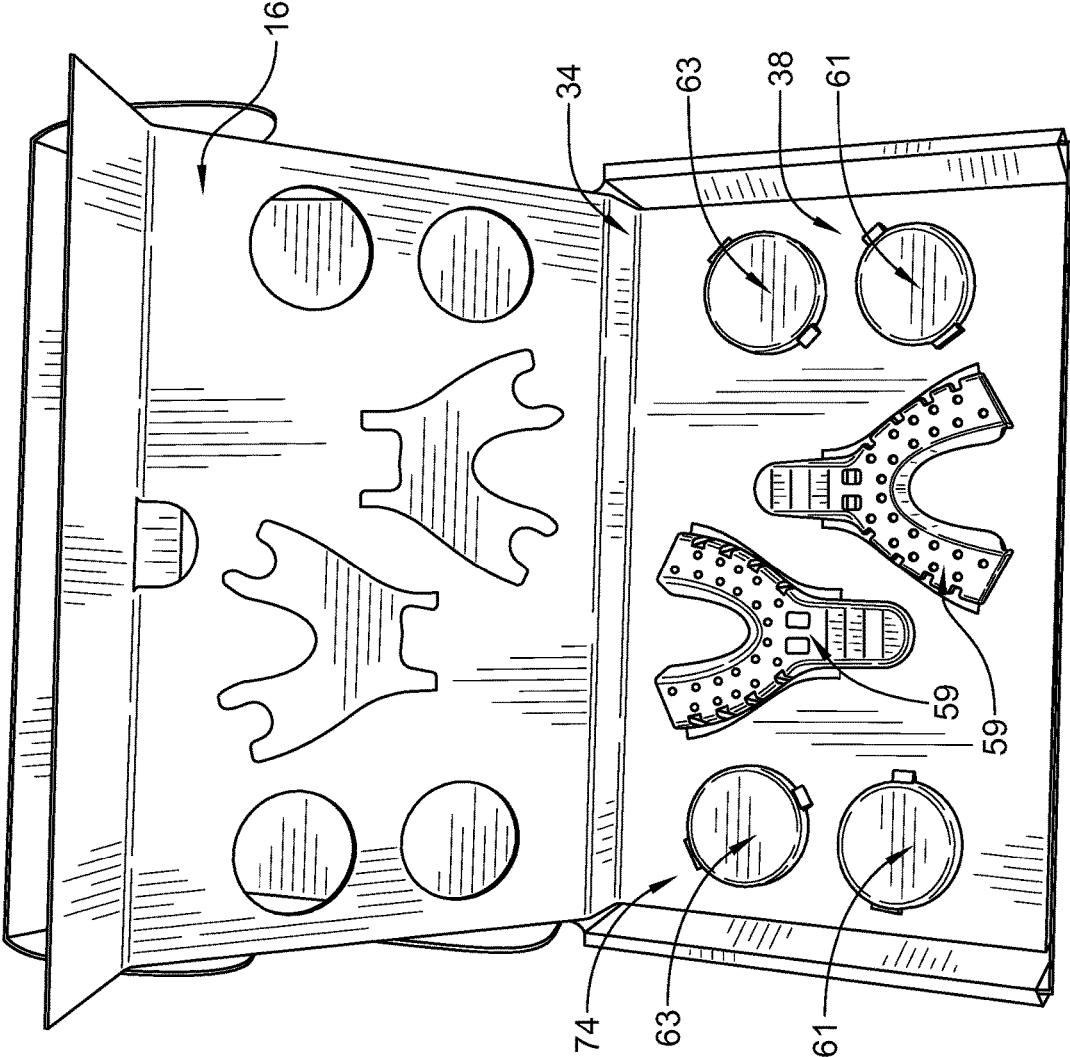

FIG. 5

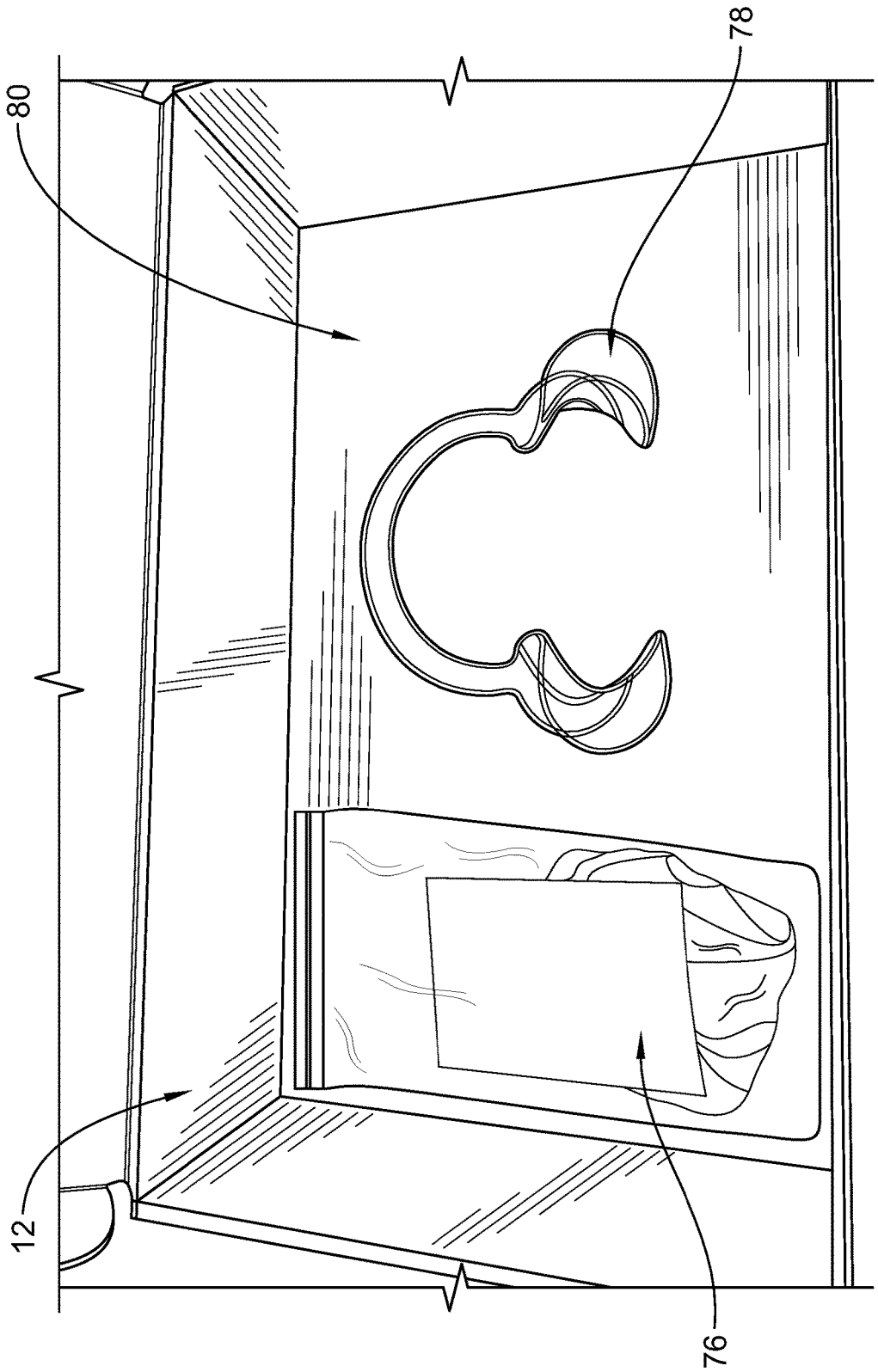

FIG. 6

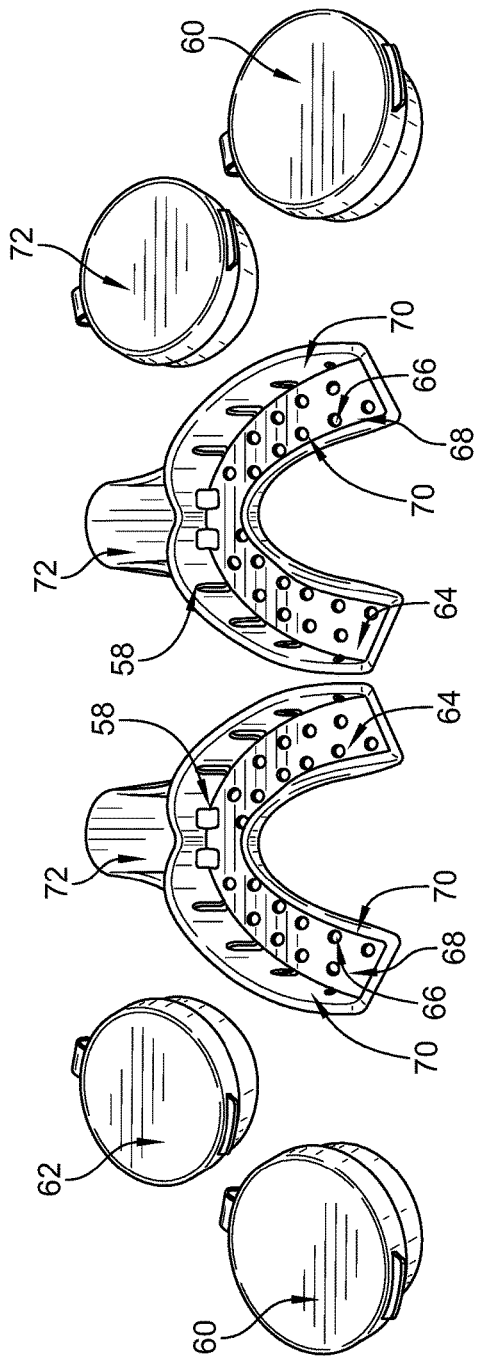

FIG. 7



FIG. 9

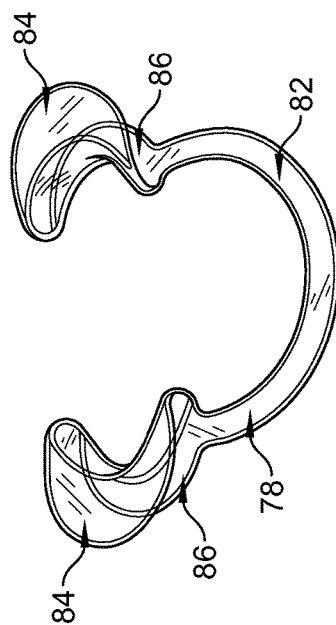

FIG. 8

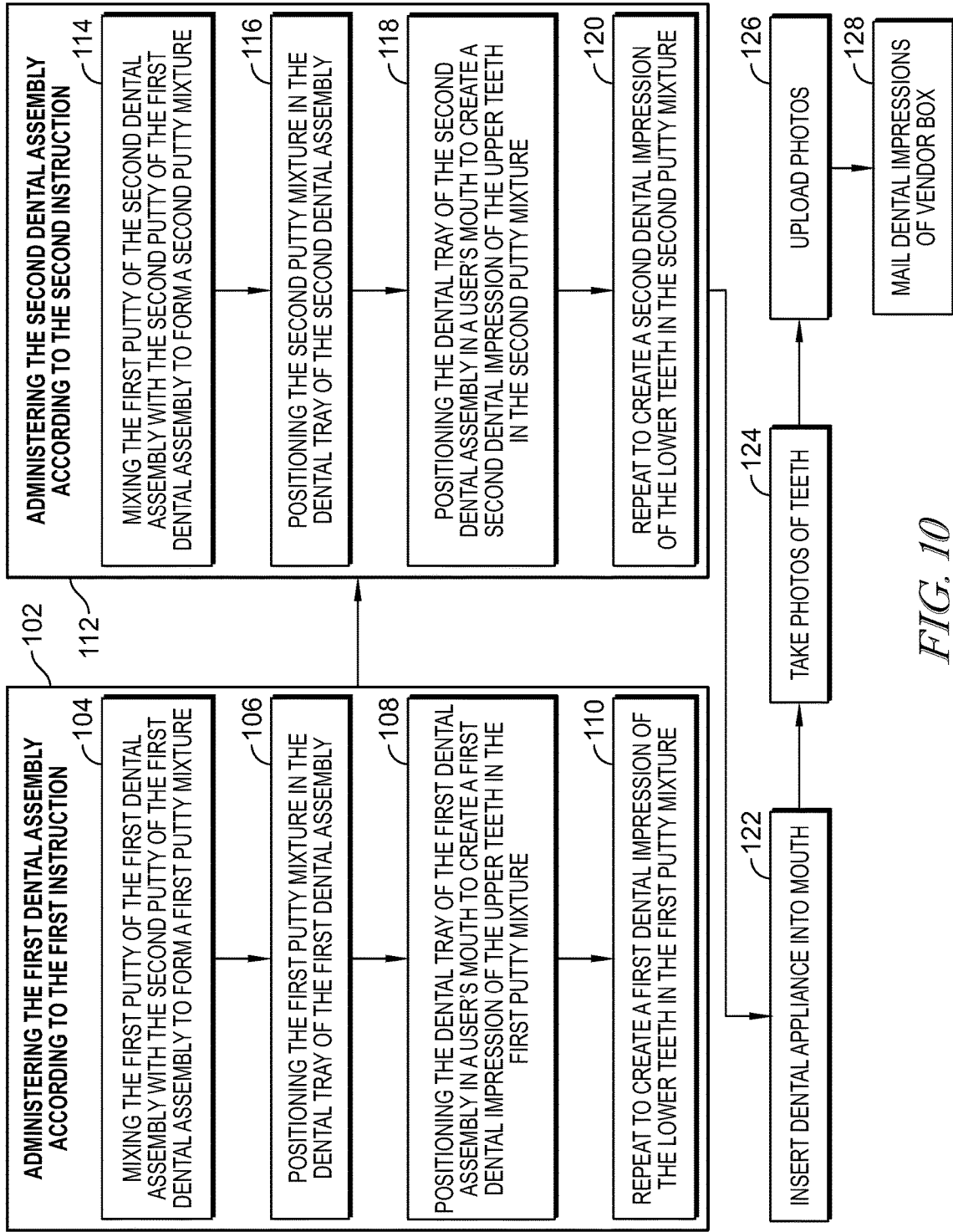

FIG. 10

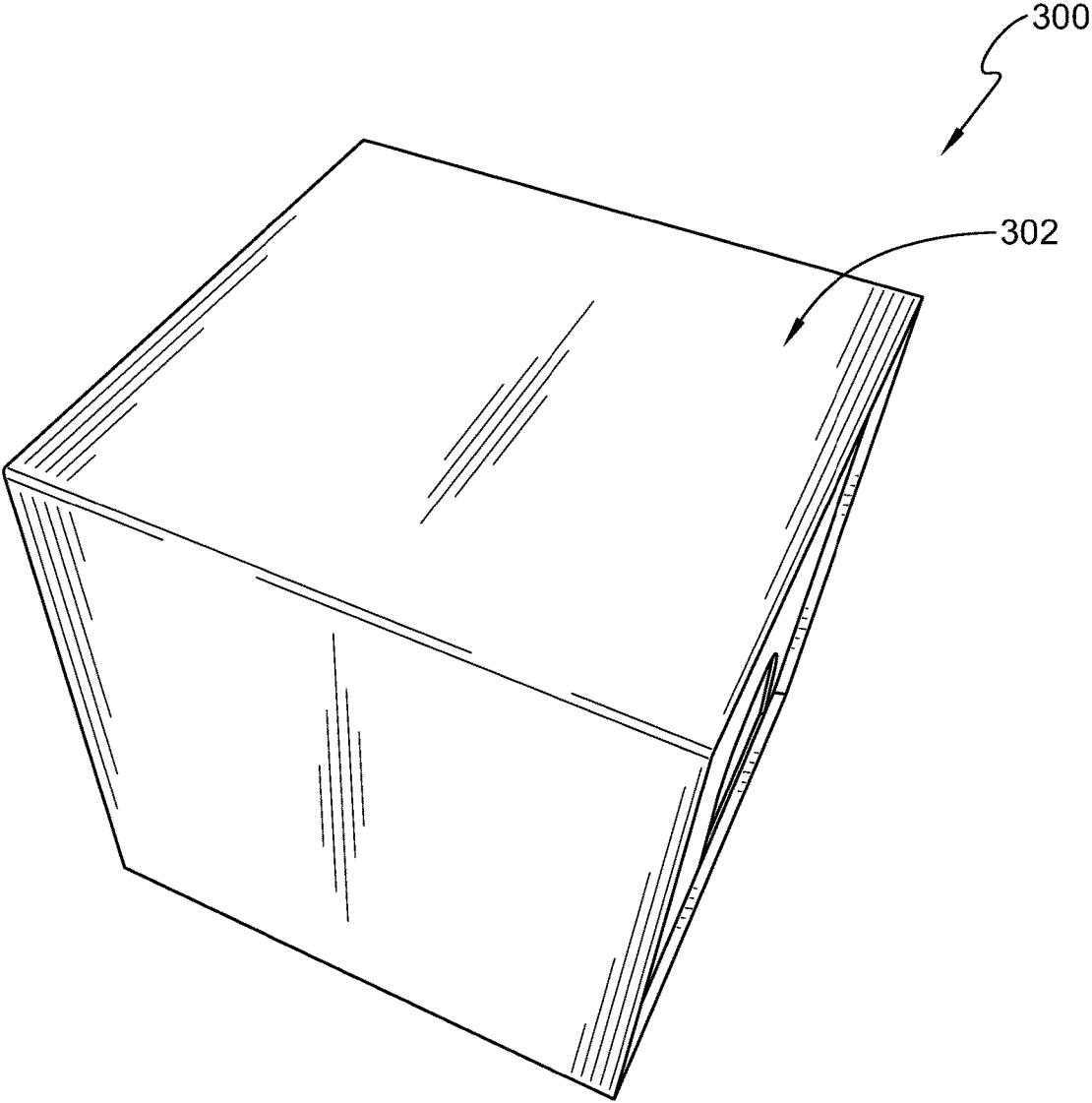

FIG. 11

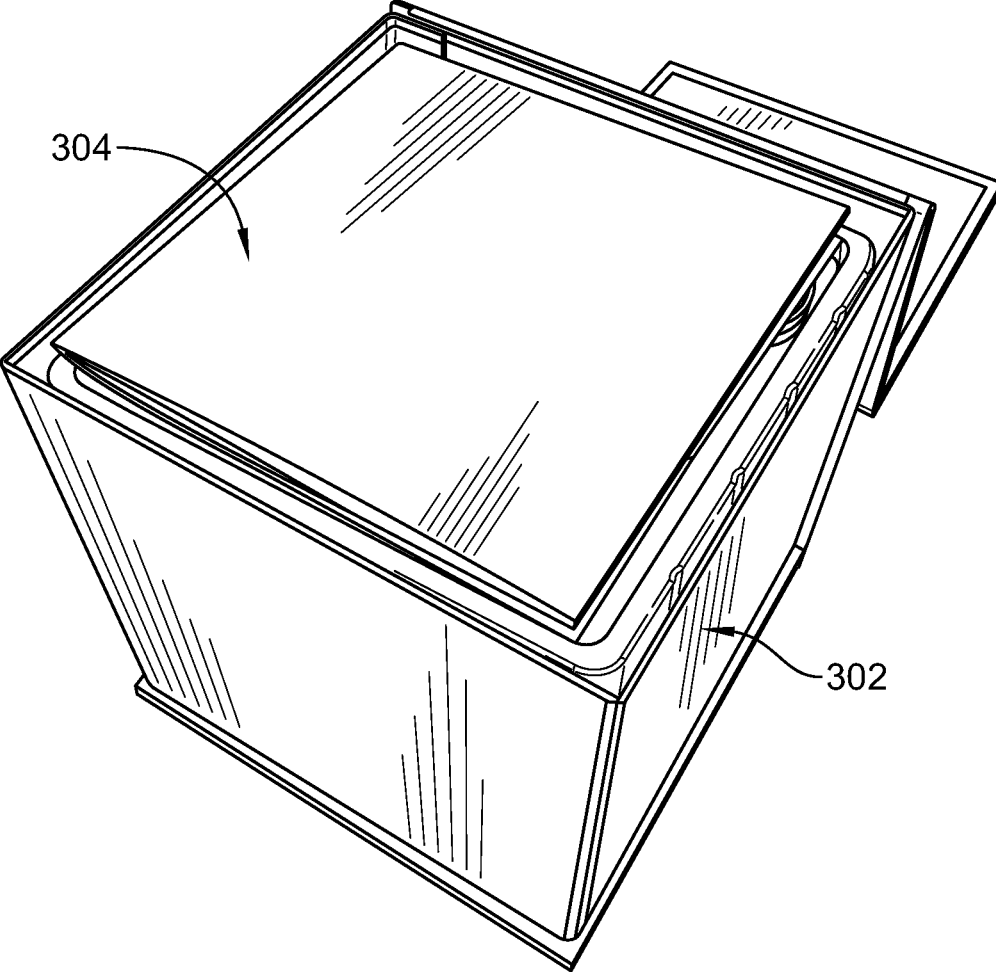

FIG. 12

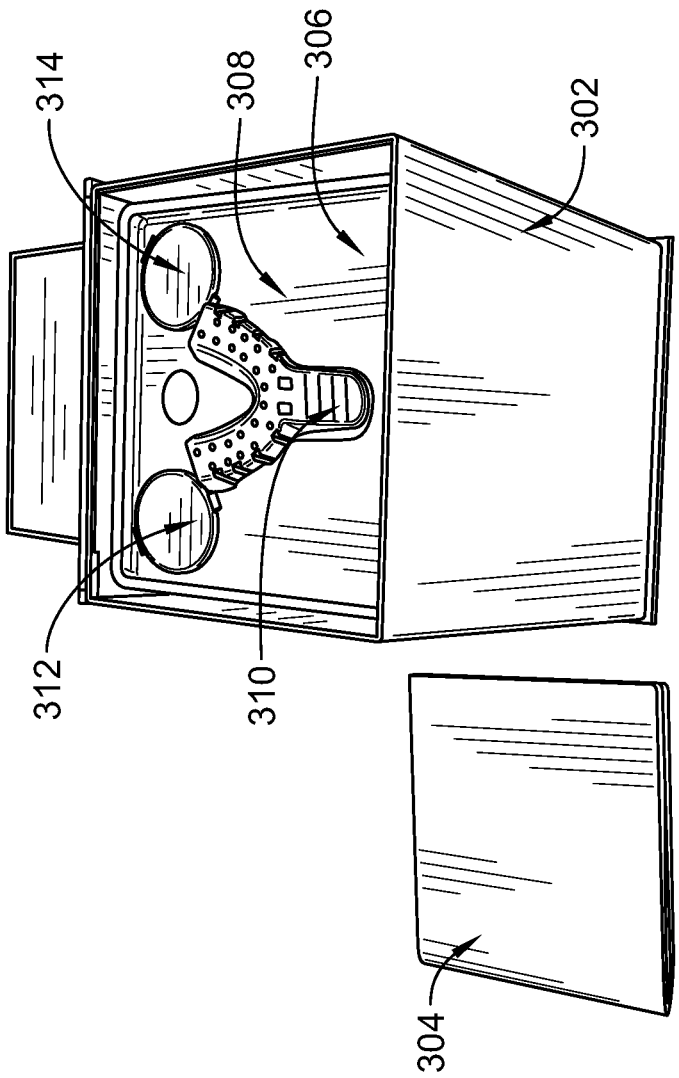

FIG. 13

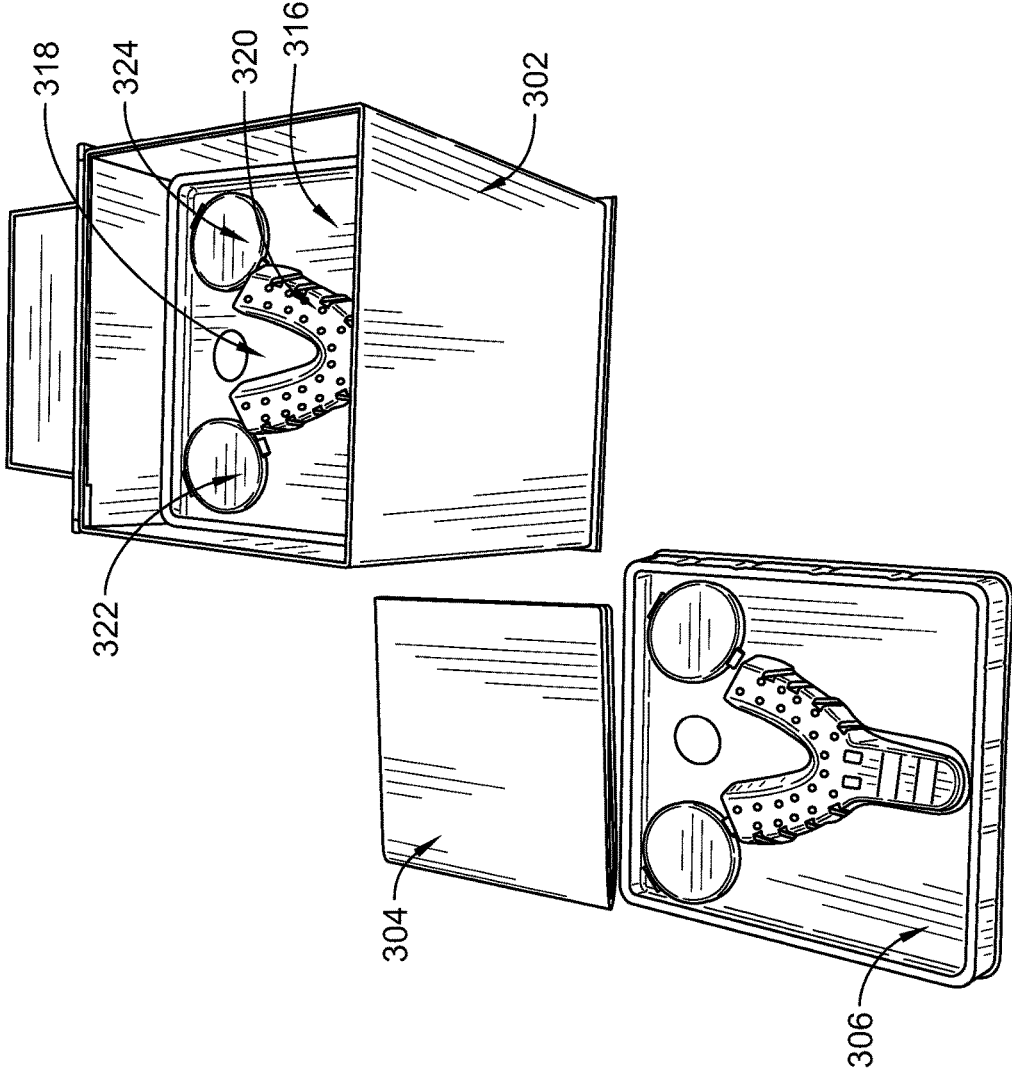

FIG. 14

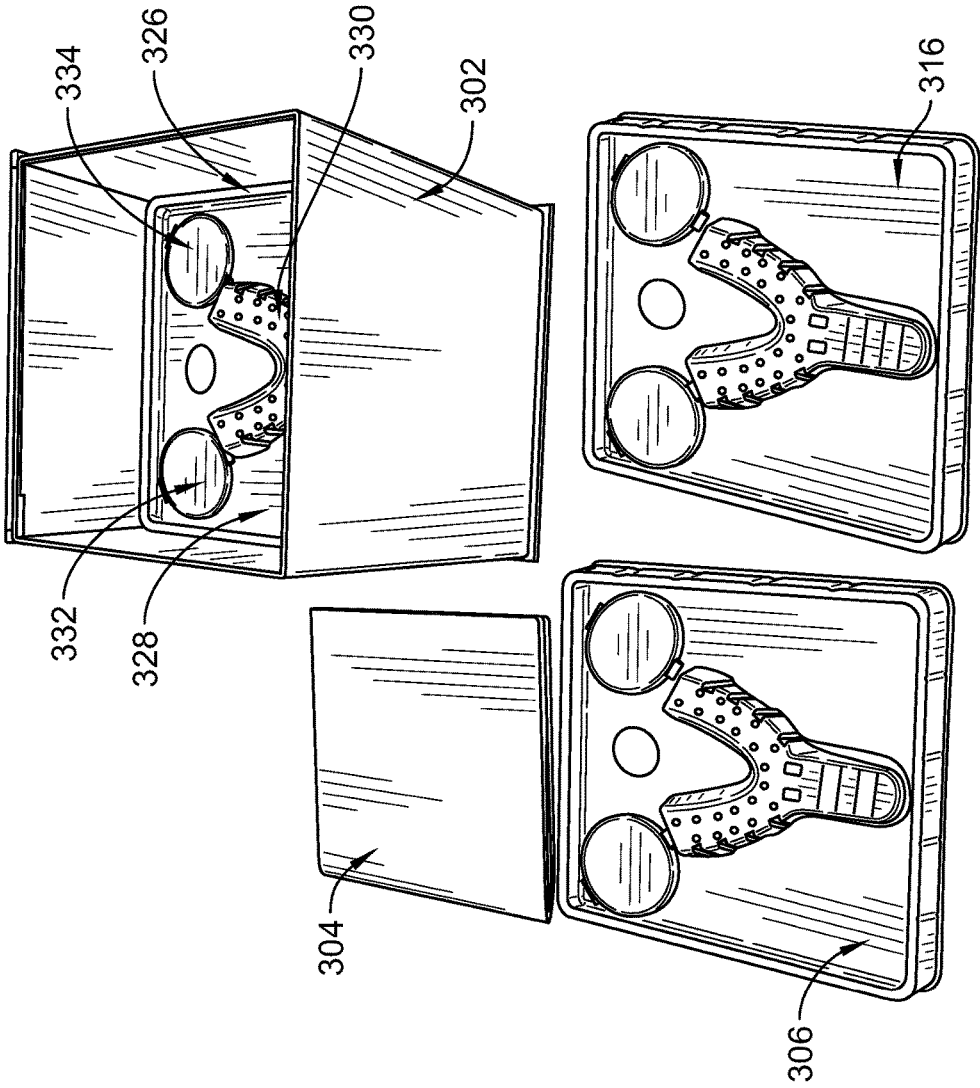

FIG. 15

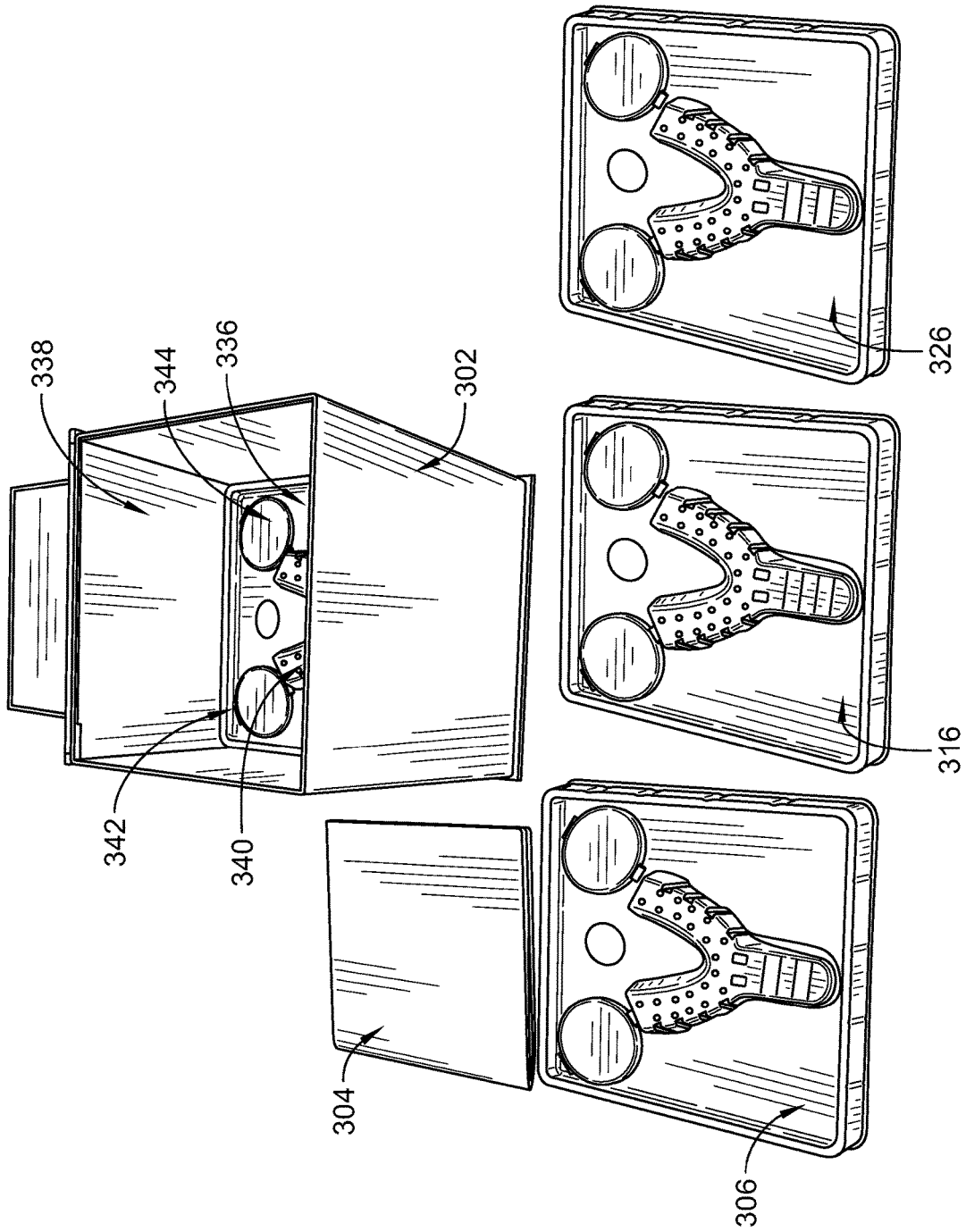

FIG. 16

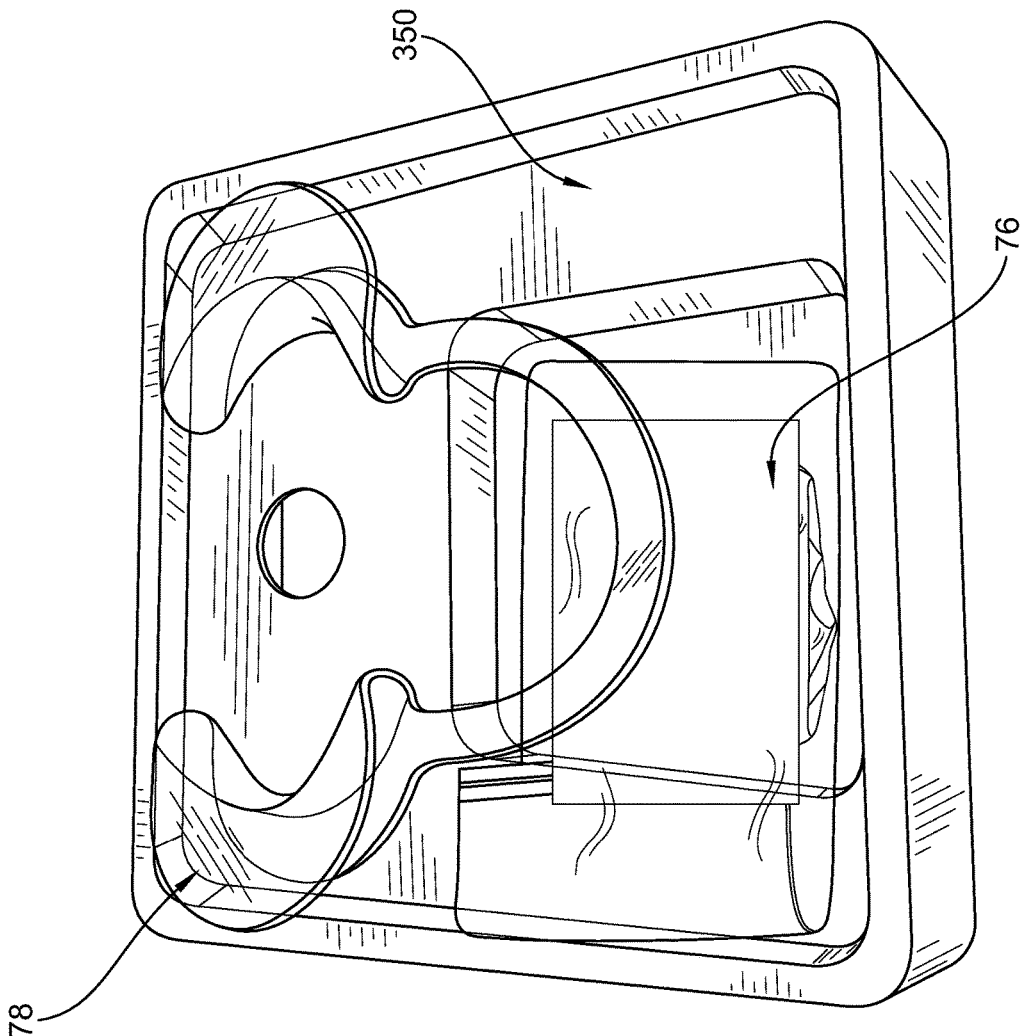

FIG. 17

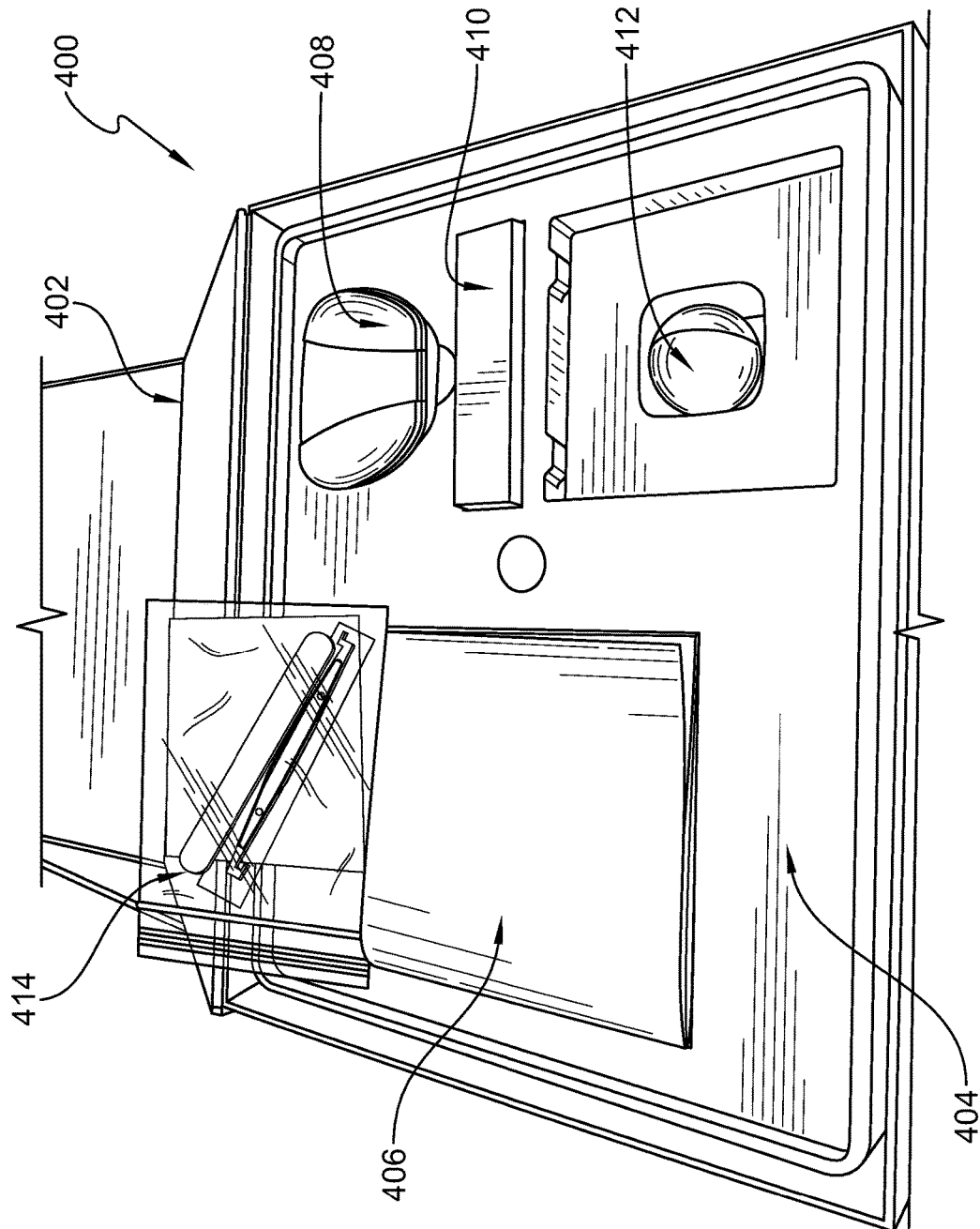

FIG. 18

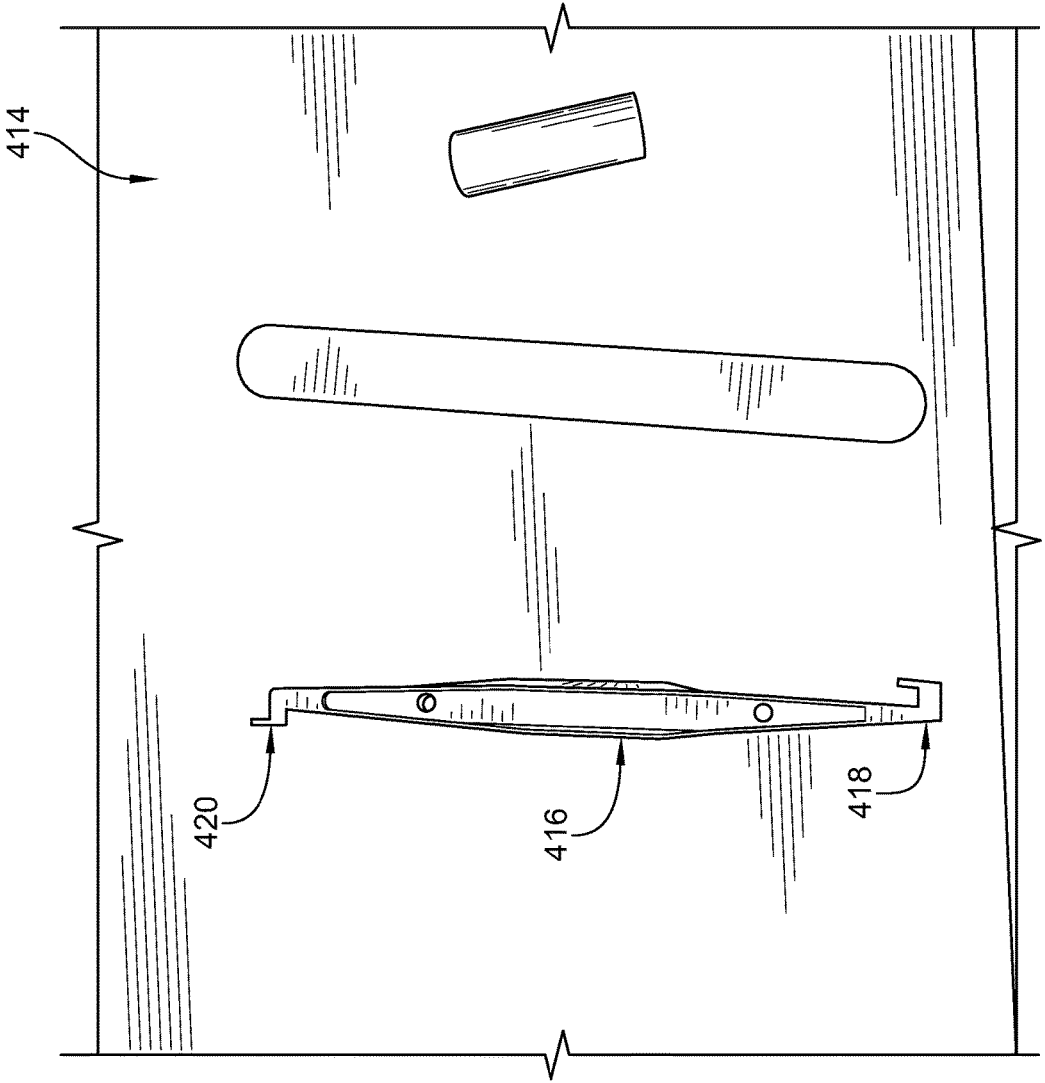

FIG. 19

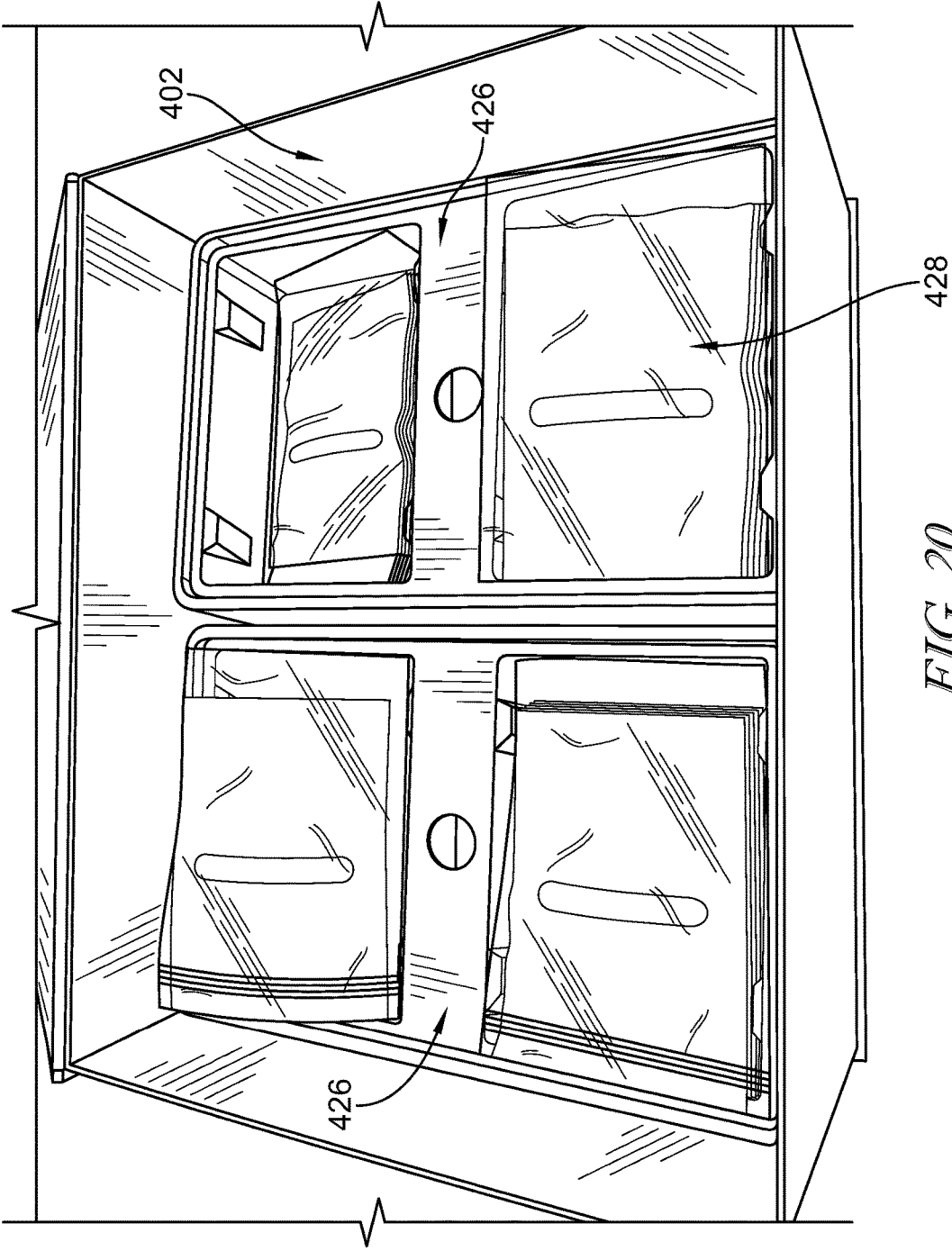

FIG. 20

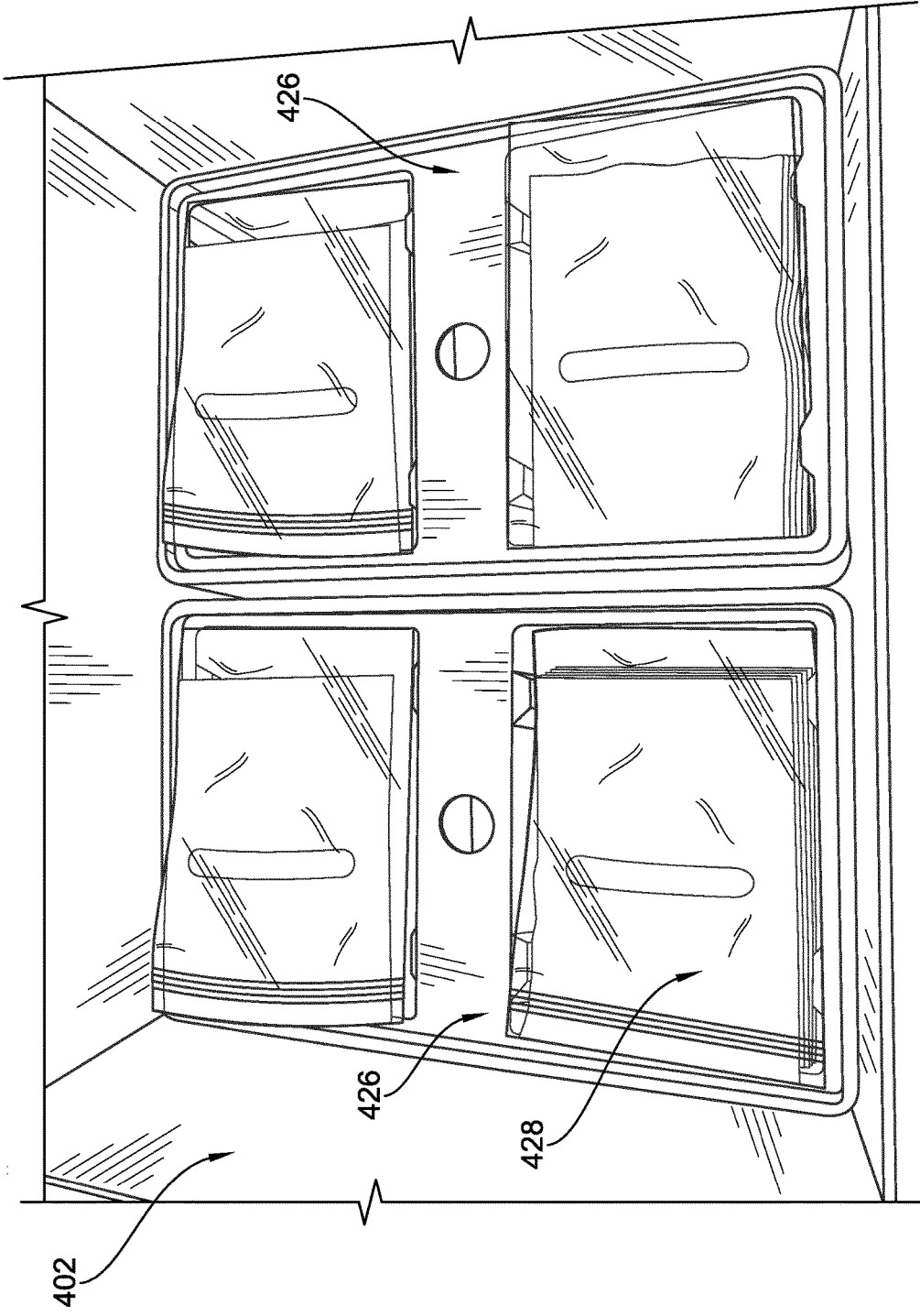

FIG. 21

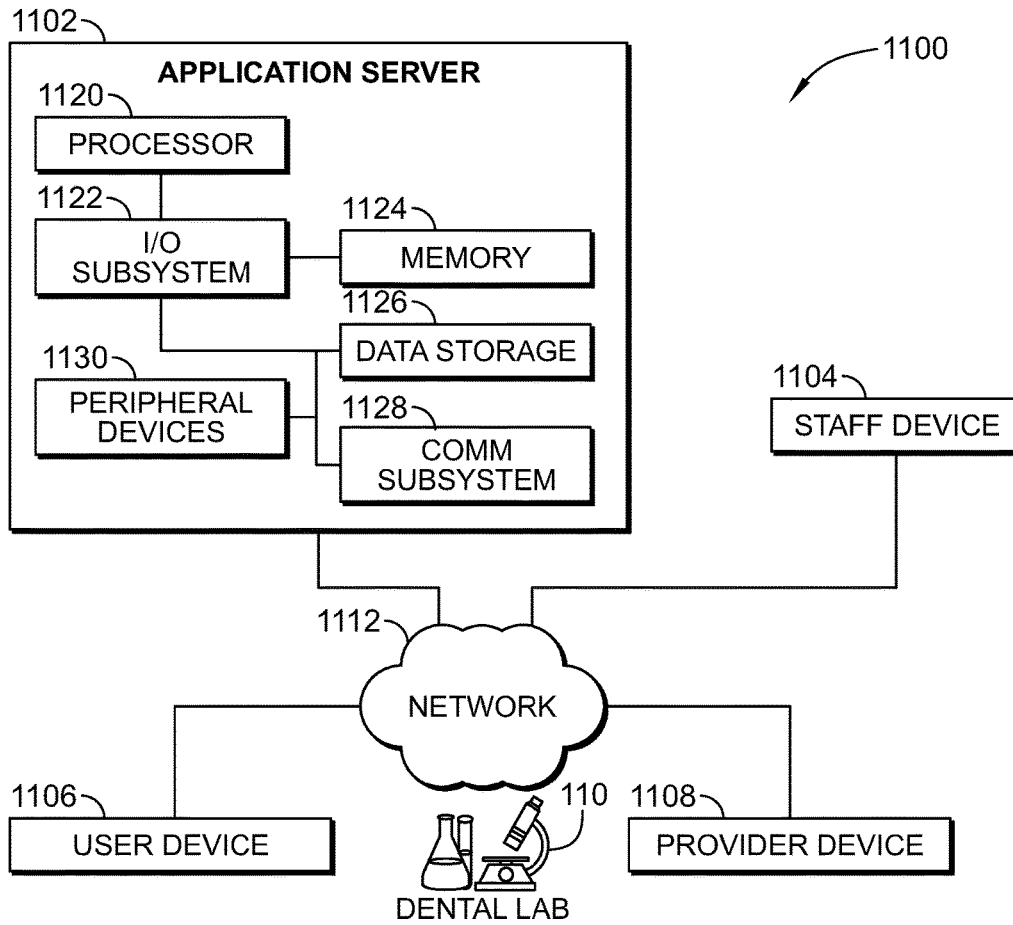

FIG. 22

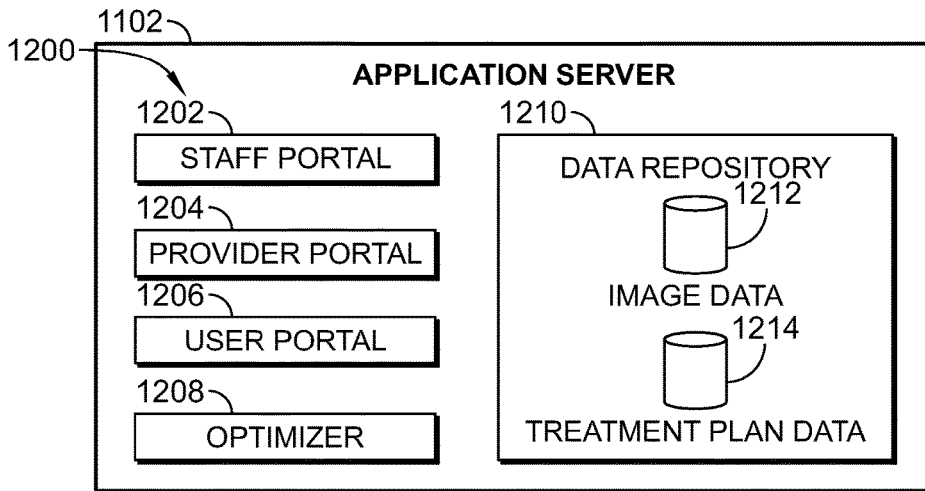

FIG. 23

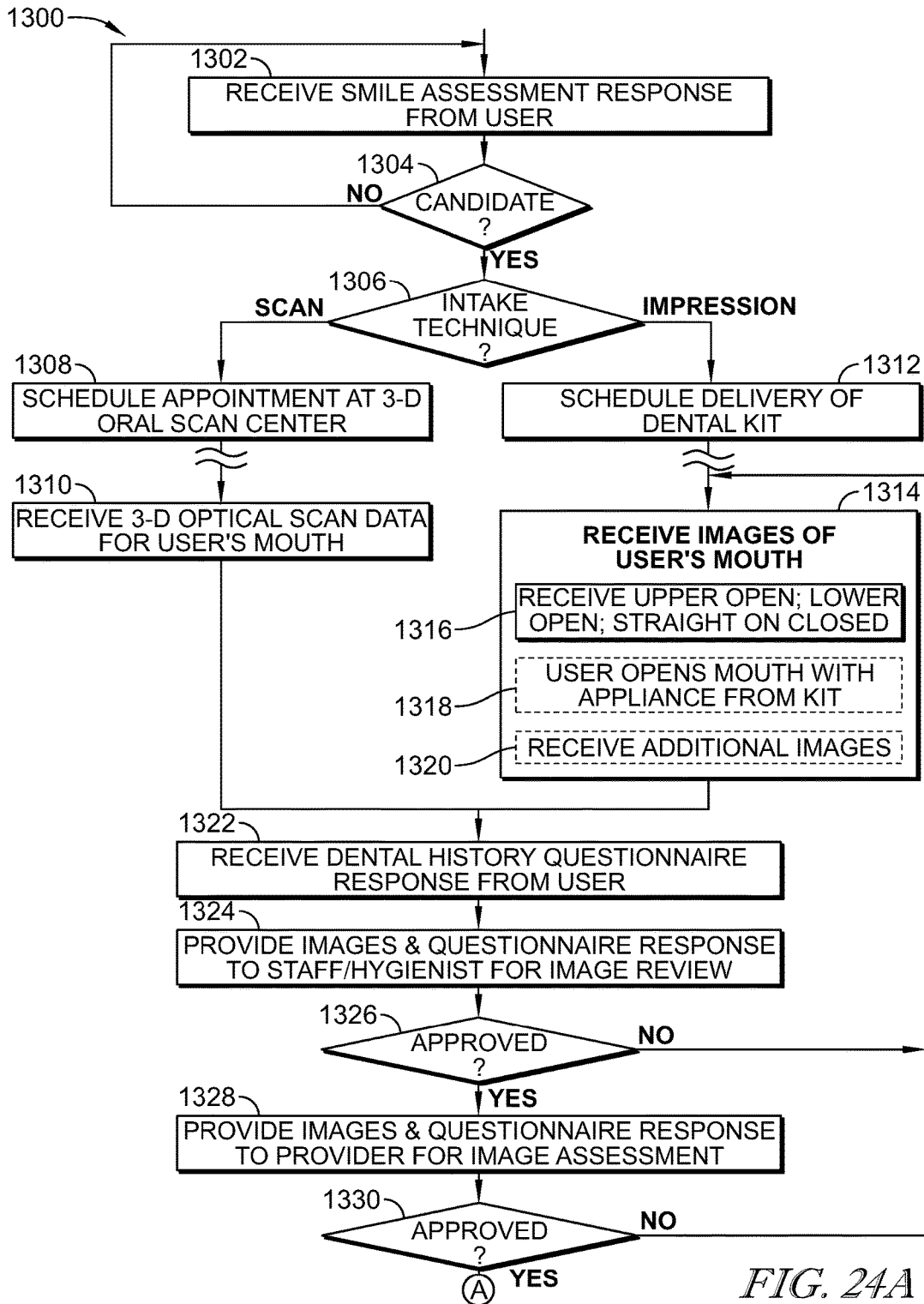

FIG. 24A

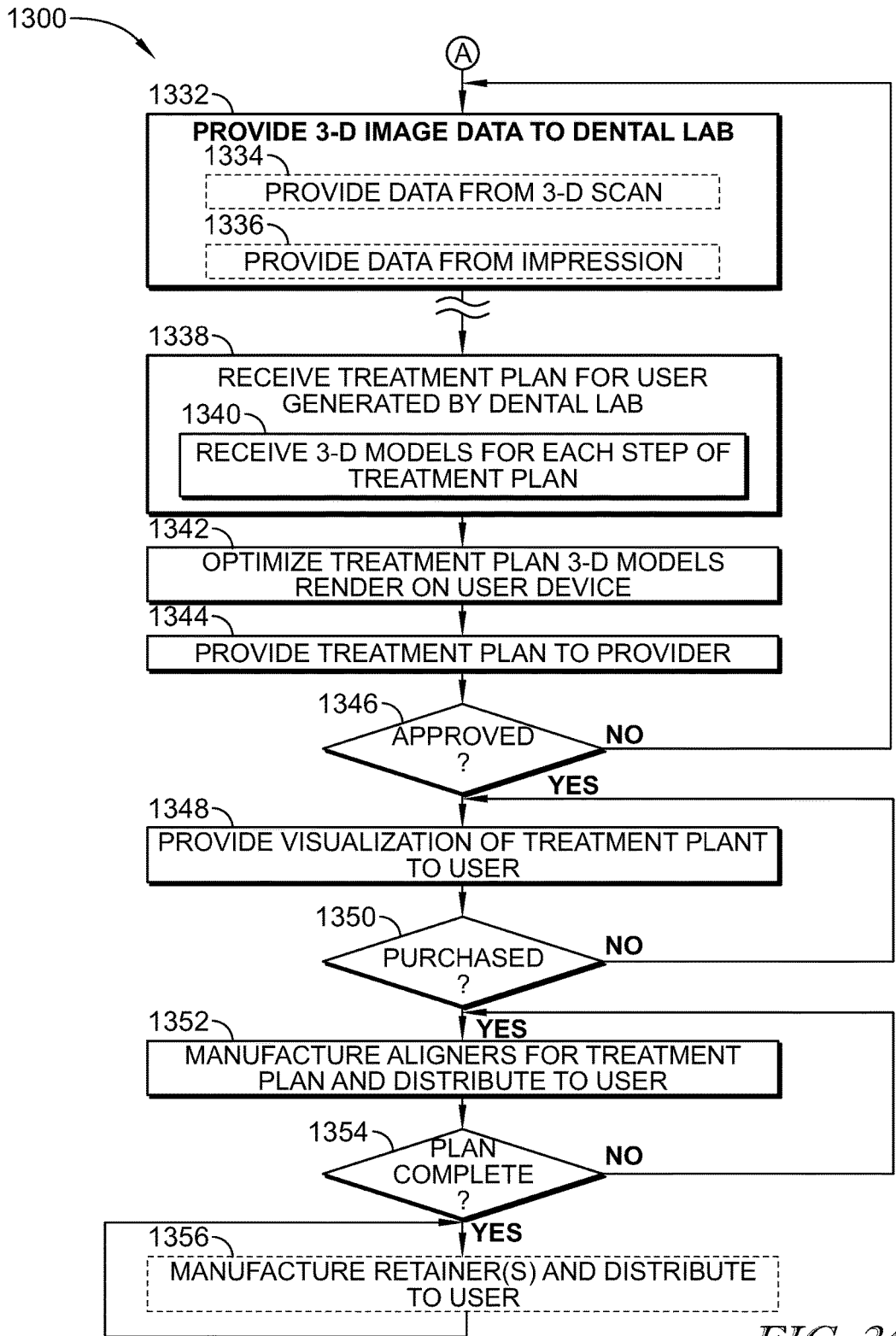

FIG. 24B

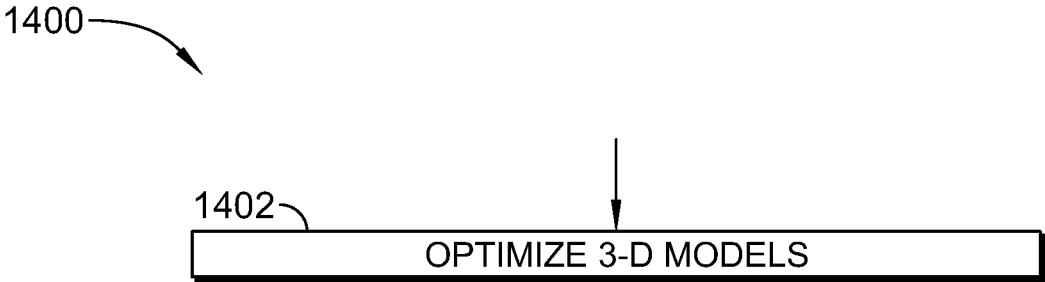

FIG. 25

1500

FREE SMILE ASSESSMENT

THE FOLLOWING QUESTIONS WILL HELP OUR DENTAL STAFF ASSESS IF COMPANY IS RIGHT FOR YOU.

① HAVE YOU WORN BRACES OR INVISIBLE ALIGNERS IN THE PAST? 1502

YES	NO
-----	----

② CHOOSE THE OPTION THAT BEST DESCRIBES YOUR **BIGGEST CONCERN** WITH YOUR SMILE:

FIX A SPACING ISSUE ▾

③ OF THE IMAGES BELOW, WHICH ONE BEST DESCRIBES YOUR **TEETH CROWDING**?

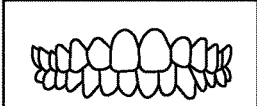
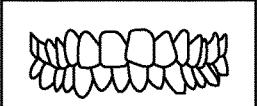
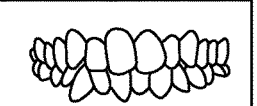
 MILD, OR NO CROWDING	 MODERATE	 EXTREME
---	---	---

④ OF THE IMAGES BELOW, WHICH ONE BEST DESCRIBES YOUR **TEETH SPACING**?

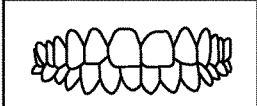
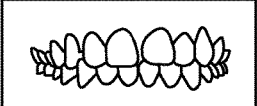
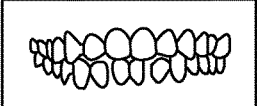
 MILD, OR NO EXTRA SPACE	 MODERATE	 EXTREME
--	---	---

• • •

1506

GET YOUR RESULTS

1504

FIG. 26

1600

MY ACCOUNT
WELCOME BACK, MAGGIE!

USER: YOUR NEXT STEP:

WHERE'S YOUR CAMERA? WITHOUT PHOTOS OF YOUR TEETH YOUR SMILE IS IN LIMBO. WE CAN'T BUILD YOUR CUSTOM TREATMENT PLAN AND WE CAN'T MOVE FORWARD. GET THAT CAMERA AND LET'S GET THOSE PHOTOS UPLOADED. IF YOU'RE HAVING ISSUES UPLOADING YOUR PHOTOS YOU CAN EMAIL THEM TO SUPPORT@COMPANY.COM

YOU'RE SCHEDULED FOR AN APPOINTMENT AT THE DENTIST AT 11:00 AM CDT, TUESDAY, MARCH 14, 2017.
THANK YOU FOR BOOKING YOUR SCAN. WE ARE LOCATED AT ADDRESS.

HELPFUL HINTS:

- YOU CAN ALWAYS CALL US AT 555-555-5555 IF YOU NEED HELP WITH DIRECTIONS.
- MAKE SURE TO BRUSH YOUR TEETH BEFORE YOUR APPOINTMENT.
 - ARRIVE A LITTLE EARLY FOR PARKING
 - THE SMILESHOP IS LOCATED INSIDE THE BUILDING.

1602

COMPLETE YOUR PHOTO ASSESSMENT



MAGGIE

FEEL FREE TO CALL US AT 555-555-5555 FOR QUESTIONS REGARDING SCHEDULING.

FIG. 27

1700 ↗

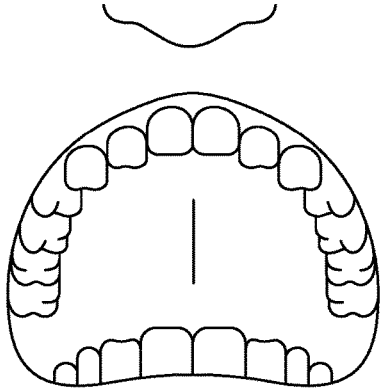
1



UPPER, OPEN

MOUTH OPEN, LOOKING UP. MAKE SURE WE SEE YOUR BACK MOLARS.

UPLOAD A PHOTO

↖ 1704

FIG. 28A

1700

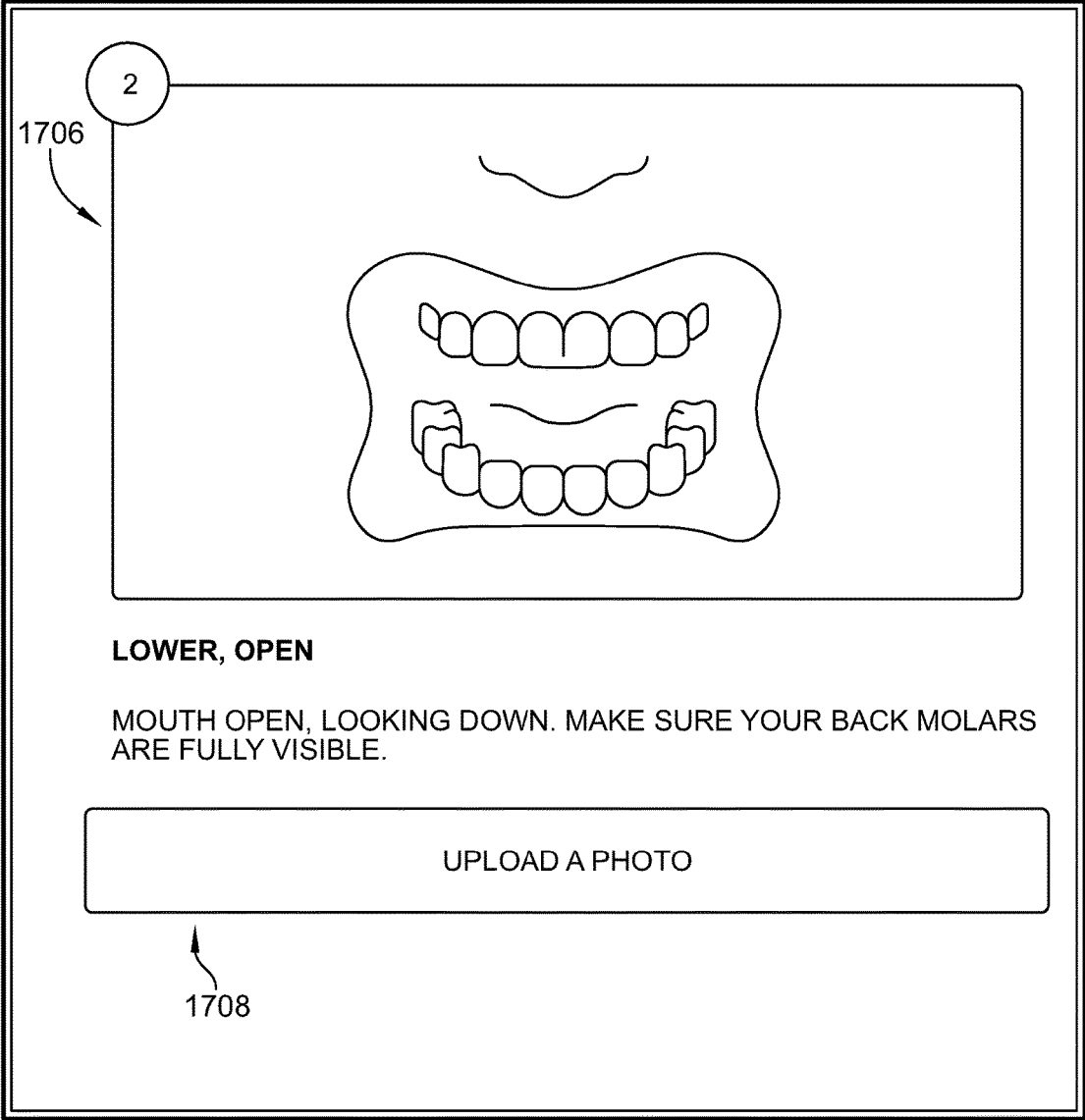

FIG. 28B

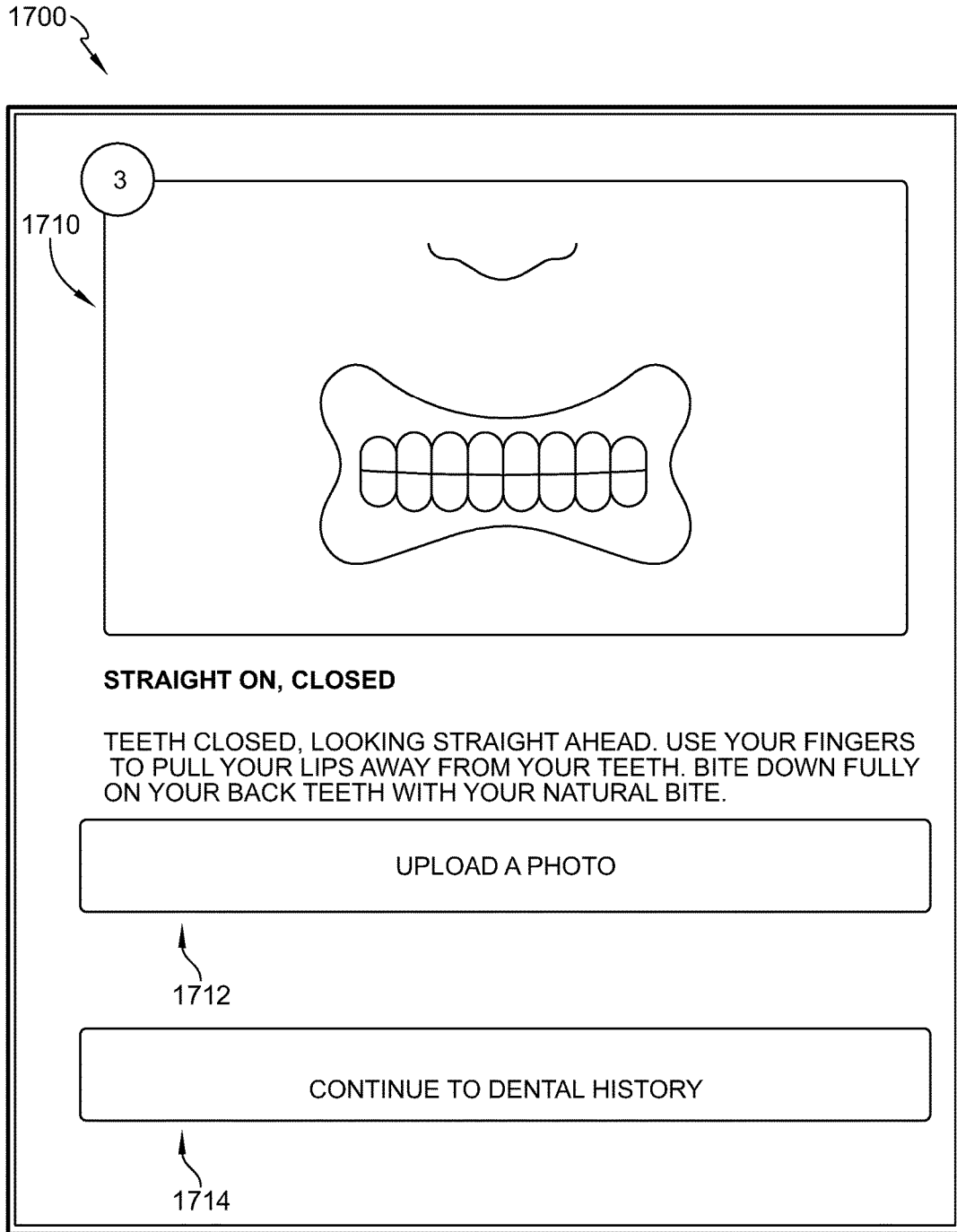



FIG. 28C

1800 ↘



YOU'RE ON YOUR WAY TO A BETTER SMILE.

THE BELOW INFORMATION WILL HELP OUR DENTAL PROFESSIONALS EVALUATE YOUR SMILE AND CREATE YOUR CUSTOM TREATMENT PLAN.

I HAVE A BONDED RETAINER 1802 ↙

YES	NO
-----	----

I HAVE BRIDGEWORK

YES	NO
-----	----

FIG. 29A

1800 ↘

1802	
I HAVE CROWNS	
YES	NO
I HAVE AN IMPACTED TOOTH	
YES	NO
I HAVE AN IMPLANT	
YES	NO
I HAVE PRIMARY (BABY) TEETH	
YES	NO
I HAVE VENEERS	
YES	NO

FIG. 29B

1800

1802

PRIMARY COMPLAINT

TELL US WHAT YOU WANT TO CHANGE ABOUT YOUR SMILE (EXAMPLE: "PLEASE FIX THE GAP IN MY FRONT TEETH," "PLEASE ROTATE MY BOTTOM RIGHT TOOTH," ETC.). OUR PROVIDERS NEED EXAMPLES OF WHAT YOU'D LIKE TO CHANGE IN ORDER TO PRESCRIBE TREATMENT. PLEASE BE AS SPECIFIC AS POSSIBLE.

WRITE YOUR COMMENTS HERE

SUBMIT

1804

FIG. 29C

1802

1800

TREATMENT OPTIONS:

BOTH

UPPER

LOWER

I HAVE BRIDGEWORK: OYES ONO

I HAVE CROWNS: OYES ONO

I HAVE AN IMPACTED TOOTH: OYES ONO

I HAVE AN IMPLANT: OYES ONO

I HAVE PRIMARY (BABY) TEETH: OYES ONO

I HAVE VENEERS: OYES ONO

DO YOU FEEL PAIN IN ANY OF YOUR TEETH?: OYES ONO

DO YOU CURRENTLY HAVE ANY HEAD, NECK, OR JAW INJURIES?: OYES ONO

DO YOU HAVE ANY SORES OR LUMPS IN OR NEAR YOUR MOUTH?: OYES ONO

DO YOU CURRENTLY EXPERIENCE: JAW CLICKING, PAIN, DIFFICULTY OPENING AND/OR CLOSING OR DIFFICULTY CHEWING?: OYES ONO

HAVE YOU NOTICED ANY LOOSENING OF YOUR TEETH OR DO YOU HAVE UNTREATED PERIODONTAL DISEASE?: OYES ONO

FIG. 29D

1800

1802

DO YOU HAVE ANY KNOWN ALLERGIES TO ANY DENTAL MATERIALS?: YES NO

I HAVE A HISTORY OF IV BISPHOSPHONATE TREATMENT.: YES NO

I AM CURRENTLY ON ACUTE CORTICOSTEROIDS OR IN IMMUNOSUPPRESSION, CHEMOTHERAPY, OR RADIATION OF HEAD/NECK.: YES NO

I HAVE HAD A BONE MARROW TRANSPLANT OR TREATMENT OF HEMATOLOGICAL MALIGNANCIES (BLOOD CANCERS) WITHIN THE PAST 2 YEARS.: YES NO

CHIEF COMPLAINT:

FIG. 29E

1804

1900

PHOTOS

ASSESSMENT STATUS
APPROVED

APPROVED TREATMENT OPTION **REQUESTED TREATMENT OPTION**
BOTH BOTH

1902 ? STRAIGHT ON, CLOSED REPLACE PHOTO

LOWER, OPEN

? UPPER, OPEN

UPPER, CLOSED

LEFT SIDE, CLOSED

RIGHT SIDE, CLOSED

STRAIGHT ON, FULL SMILE

1904 

PHOTO STATUS
1906 NEW
APPROVED
REJECTED

DOWNLOAD ZIP REJECT ALL PHOTOS SUBMIT

1908

FIG. 30A

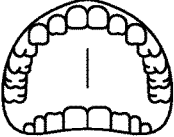
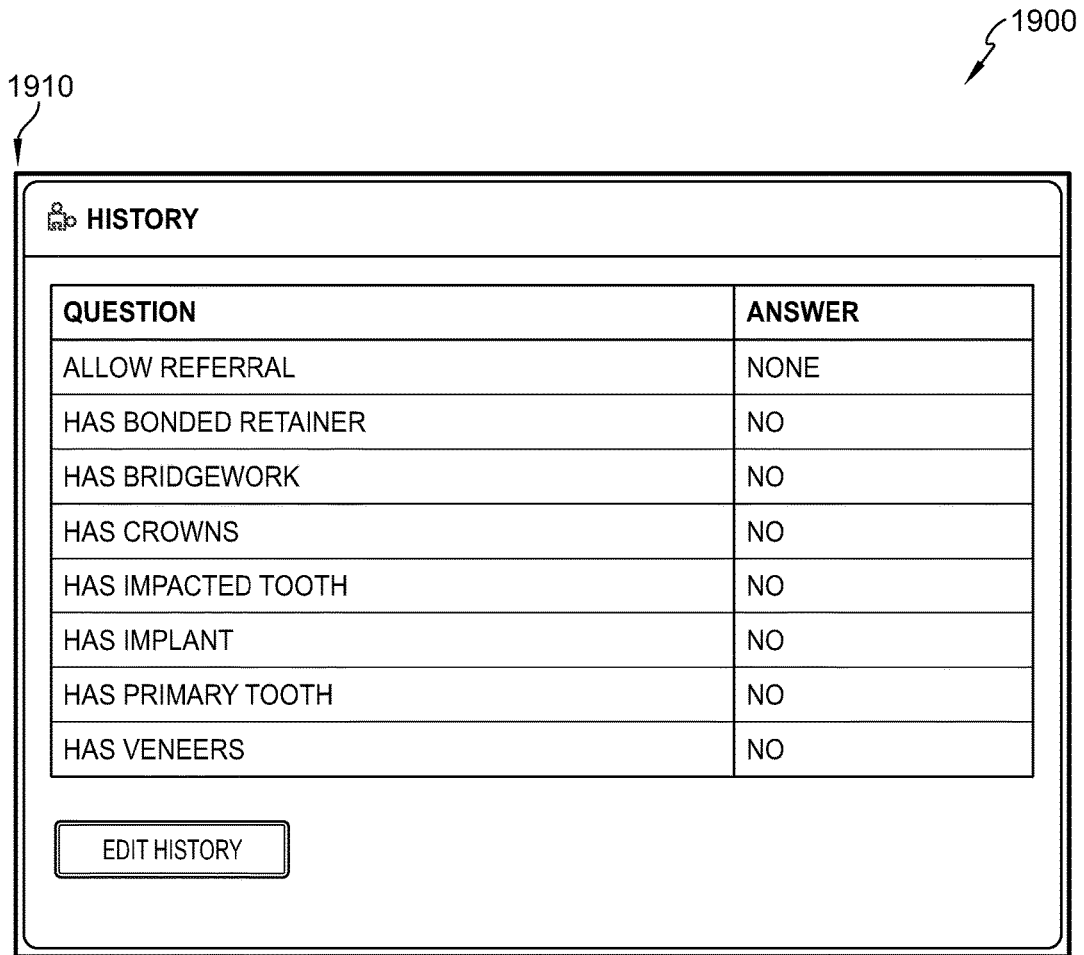

FIG. 30B

2000 ↗

2002 ↘

















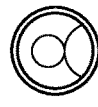











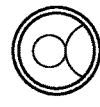



 30 CASES	 CASES	 LOGOUT
2004		
SEARCH BY PATIENT NAME OR CASE NUMBER    LIST		
 REVISE HYGCORP AGE 35 LAB CASE ID: CA455007	 MAGGIE TESTER AGE 32 LAB CASE ID: CA178920	 RRSMILELAB TESTING AGE 28 LAB CASE ID: CA092783
 ACTION REQUIRED RECOMMENDED BY HYGIENIST: APPROVE REVIEW TREATMENT PLAN	 ACTION REQUIRED RECOMMENDED BY HYGIENIST: APPROVE REVIEW TREATMENT PLAN	 ACTION REQUIRED RECOMMENDED BY HYGIENIST: REVISE REVIEW TREATMENT PLAN
 CHIEF COMPLAINT WQWQ	 CHIEF COMPLAINT MY FRONT TEETH ARE CROOKED. I HAVE A GAP BETWEEN MY BOTTOM TEETH	 CHIEF COMPLAINT CROOKED
 DATE OF LAST ACTIVITY FRIDAY, FEBRUARY 17, 2017 9:58 A.M. UTC	 DATE OF LAST ACTIVITY TUESDAY, FEBRUARY 14, 2017 4:15 P.M. UTC	 DATE OF LAST ACTIVITY TUESDAY, FEBRUARY 14, 2017 2:09 P.M. UTC
 MORPHY REJECTCORP AGE 40 LAB CASE ID: CA047616	 MARY CORPREVISED AGE 42 LAB CASE ID: CA890399	 ISAC NONCROP AGE 43 LAB CASE ID: CA674176
 ACTION REQUIRED RECOMMENDED BY HYGIENIST: APPROVE REVIEW TREATMENT PLAN	 ACTION REQUIRED RECOMMENDED BY HYGIENIST: APPROVE REVIEW TREATMENT PLAN	 ACTION REQUIRED RECOMMENDED BY HYGIENIST: APPROVE REVIEW TREATMENT PLAN
 CHIEF COMPLAINT CYG	 CHIEF COMPLAINT CROOKED	 CHIEF COMPLAINT CYG
 DATE OF LAST ACTIVITY TUESDAY, FEBRUARY 7, 2017 1:50 P.M. UTC	 DATE OF LAST ACTIVITY TUESDAY, FEBRUARY 7, 2017 1:50 P.M. UTC	 DATE OF LAST ACTIVITY TUESDAY, FEBRUARY 7, 2017 1:50 P.M. UTC
 MONALISA CORPHYG AGE 45 LAB CASE ID: CA420202	 HYGIENE ACCEPT AGE 21 LAB CASE ID: CA973141	 MONALISA CORPHYG AGE 45 LAB CASE ID: CA420202

FIG. 31A

2000

2006

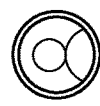
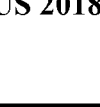
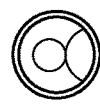

2006

LOGOUT

SEARCH BY PATIENT NAME OR CASE NUMBER

2008

△ CASES

FORMS & RECORDS

CASE INBOX

LAB

PATIENT TREATMENT PLAN

PATIENT TREATMENT PLAN

⚙️ EVALUATE TREATMENT PLAN

STATUS: NEW
 REVISION: 2
 LAB: SMILELAB
 LAB CASE: CA178920

TREATMENT PLAN
 02-14-2017 04:15 PM

💬 CHIEF COMPLAINT
 MY FRONT TEETH ARE CROOKED. I HAVE A GAP BETWEEN MY BOTTOM TEETH.

📷 PHOTO ASSESSMENT

UPPER, CLOSED

 [VIEW PHOTO >>](#)

UPPER, OPEN

 [VIEW PHOTO >>](#)

LOWER, OPEN

 [VIEW PHOTO >>](#)

STRAIGHT ON, CLOSED

 [VIEW PHOTO >>](#)

STRAIGHT ON, FULL SMILE

 [VIEW PHOTO >>](#)



MAGGIE TESTER
 NASHVILLE TN
 AGE 32

CASE: C1608-TESTEM-231498
 PATIENT MRN: TESTEMAGG961430

RECOMMENDED BY HYGIENIST: APPROVE

✓ APPROVE

✎ REVISE

✕ REJECT

2010

FIG. 31B

2000

2006



CASES



LOGOUT

PATIENT TREATMENT PLAN

FORMS & RECORDS

FORMS & RECORDS

PHOTO ASSESSMENT

2012

SEARCH BY PATIENT NAME OR CASE NUMBER

MAGGIE TESTER
 NASHVILLE TN
 AGE 32
 CASE: C1608-TESTEM-231498
 PATIENT MRN: TESTEMAGG961430

RECOMMENDED BY HYGIENIST: APPROVE

FIG. 31C

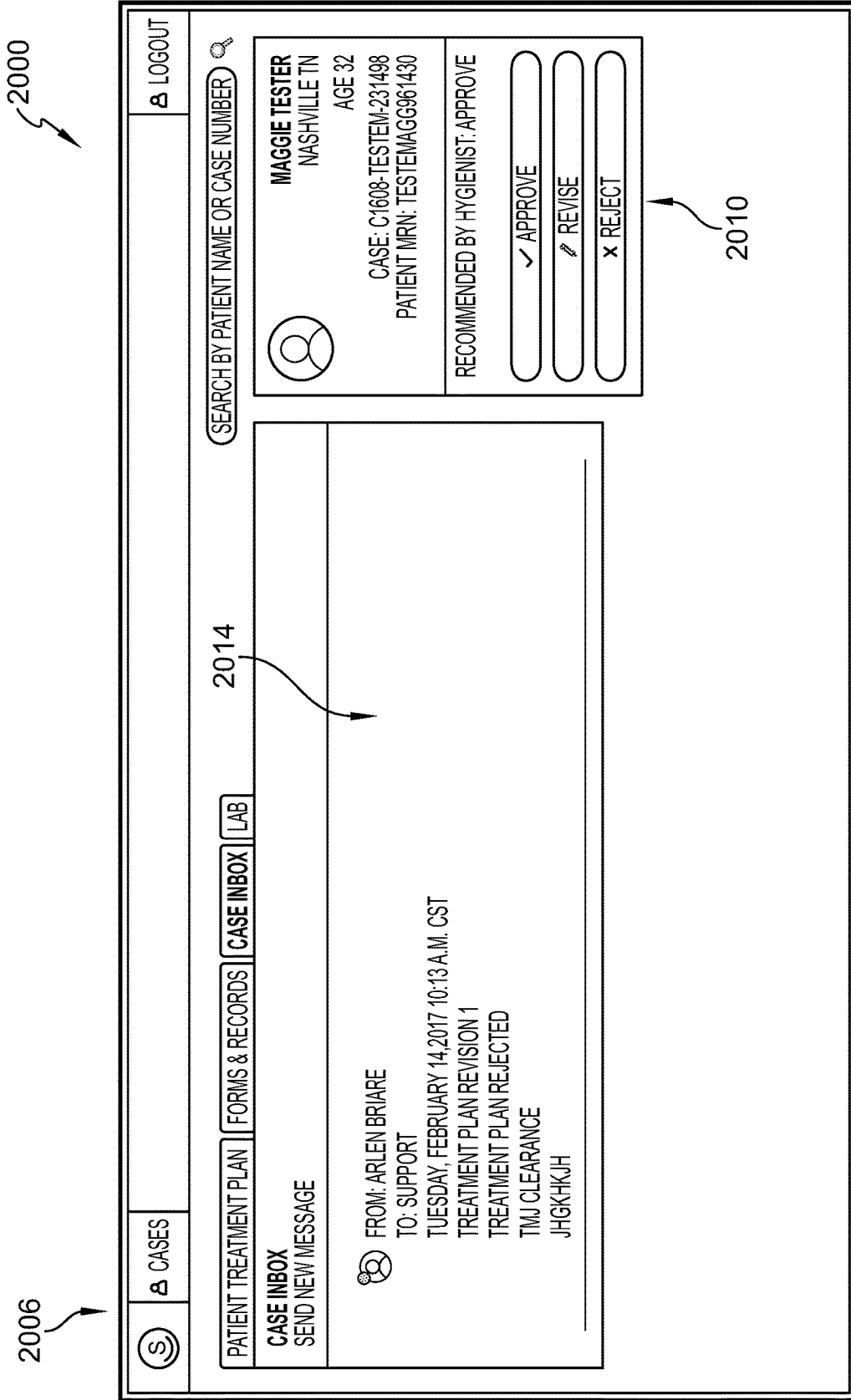

FIG. 31D

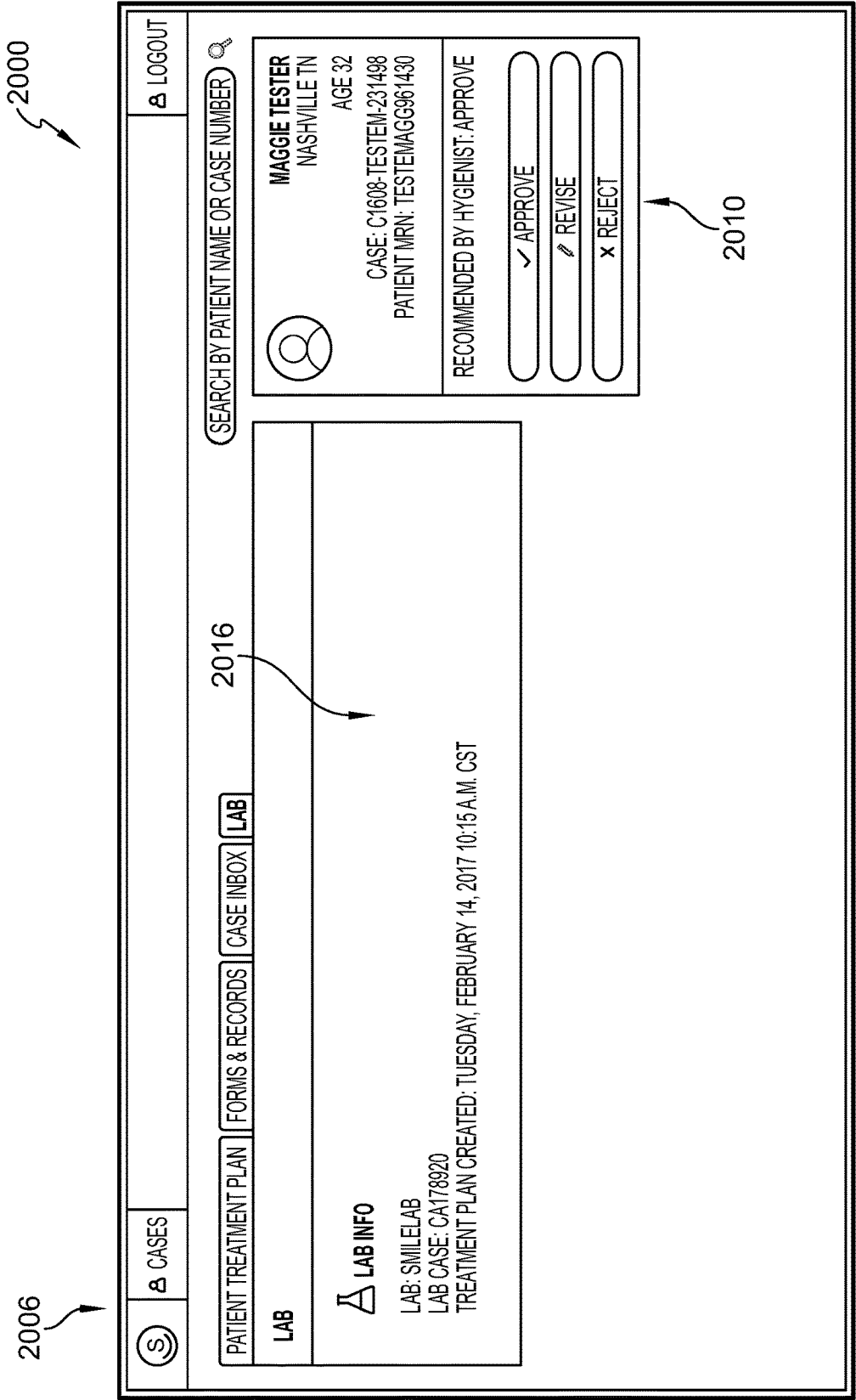

FIG. 31E

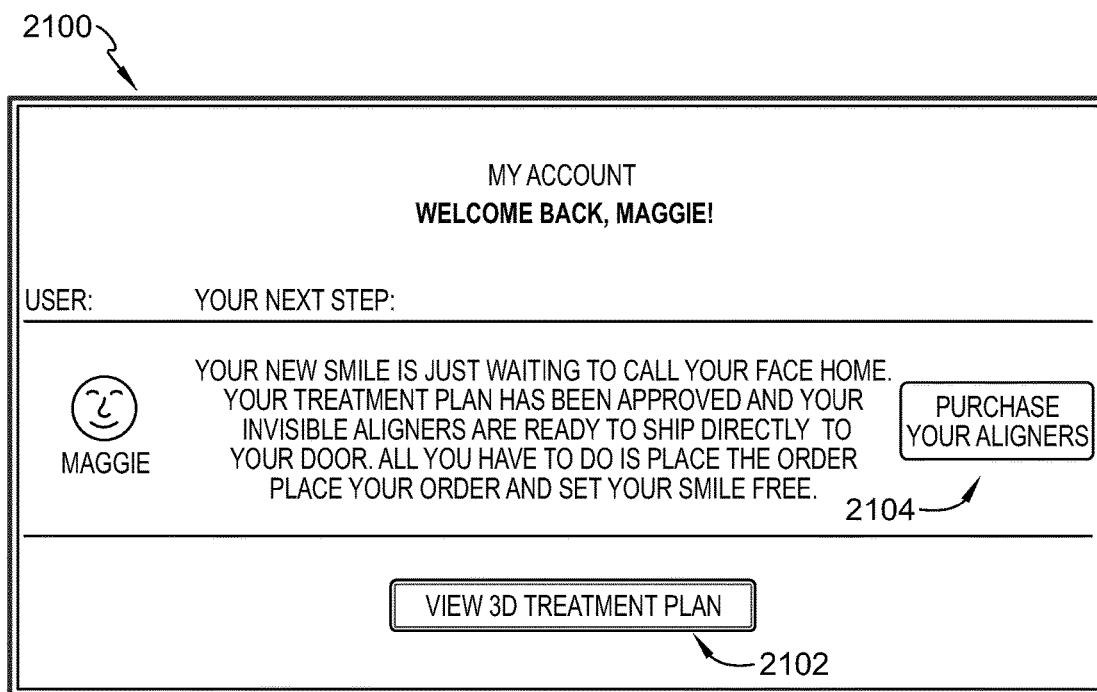

FIG. 32

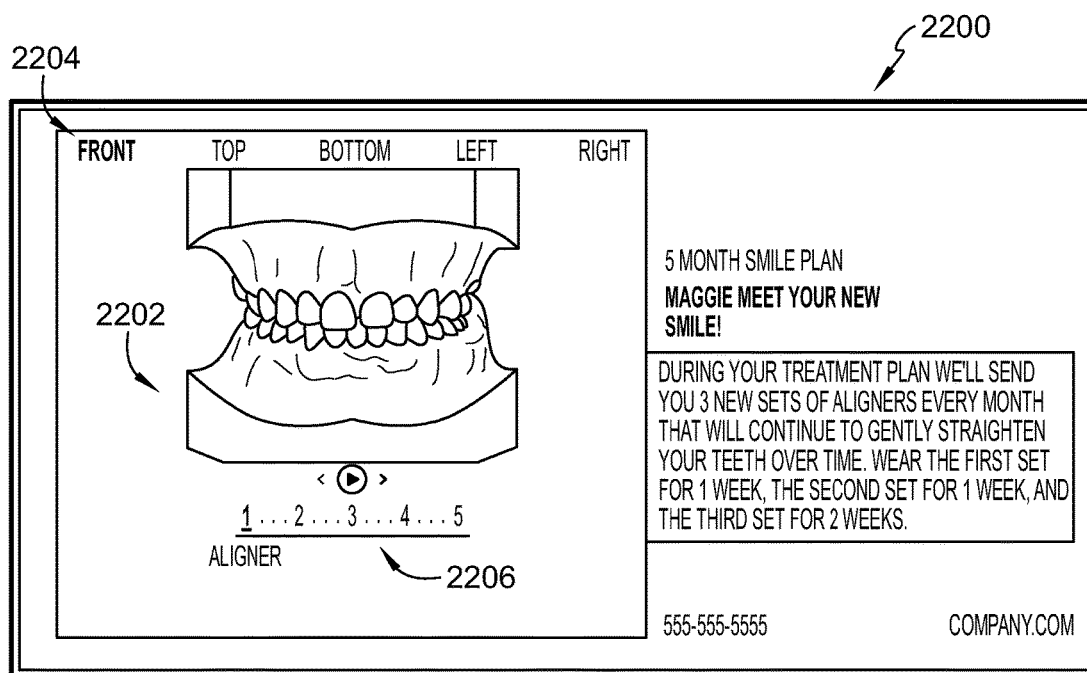

FIG. 33

CASE LINKS ⊕

NO CASE LINKS DEFINED.

PRESCRIPTIONS

STATUS	PROVIDER	PRODUCT	RX DATE	LAB	LAB CASE ID	END DATE	
ACTIVE PRESCRIPTION	LP001218	S104BA-ALIGNER - 4 MONTH	THURSDAY, MARCH 2, 2017 6 A.M. UTC	SL	CAT34723	NONE	VIEW
	LP0013646	S104BA-ALIGNER - 4 MONTH	NONE	SL	CAT34723	THURSDAY, MARCH 2, 2017 3:35 P.M. UTC	VIEW

TREATMENT PLAN REVISIONS (NEW) ⊕

REVISION	STATUS	DATE CREATED	UPDATED BY	CREATED BY	ASSETS	ACTION
1	RESUBMITTED	03-02-2017 2:45 AM			NEW SMILE PLAN REVISION (CUSTPREV) NEW SMILE PLAN (CUSTPREV)	

ORDERS

ORDER NO	ORDER DATE	PAID AMOUNT	DISCOUNT	STATUS	STATUS DATE	SOURCE	PRODUCT
VIEW ORDER S1702416C0A9C2656	MONDAY, FEBRUARY 20, 2017 12:44 P.M. UTC	0	-95.00	PROC-PROCESSING	MONDAY, FEBRUARY 20, 2017 12:44 P.M. UTC	SCC-WEB SITE	SCE/KS
							GO TO SCHEDULING

FIG. 34A

2310 ↗

2310 ↗
↘ 2300

CASE

CONTACT AS NEEDED

CASE # CFA5D890BC4D2

CASE ID 116840

PATIENT *****

DOB: ****

CUSTOMER MRN: M269FA0A889A2

SHIPPING ADDRESS

PHONE 410-212-7736 (SHIPPING)

410-212-7736 (OTHER)

GENDER UNKNOWN

TRAY SIZE MEDIUM

STATUS/REASON SETUP READY FOR REVIEW

CHIEF COMPLAINT CUSTOMER IS CONCERNED WITH CLOSING THE SPACING ON BOTH UPPER AND LOWER TEETH. WANTS TO BE ABLE SMILE IN PICTURE. ALSO, CUSTOMER SINGS AND DOESN'T LIKE TO OPEN HIS MOUTH DUE TO THE SPACING OF HIS TEETH.

PRE-AUTH: SCAN STORE SMILE PAY

VISA EXP

CASE PRIORITY MESSAGE

NO PRIORITY MESSAGE FOR THIS CASE

VIEW PHOTO ASSESSMENT

ADD PATIENT INSURANCE

VIEW EMAILS

FIG. 34B

2312 ↗

JOURNAL			NOTE	AUDIENCE
MONDAY, MARCH 6, 2017 12:28 P.M. UTC	E-MAILED ***** TO REVIEW THE IP BY: *****@***	STAFF		
FRIDAY, MARCH 3, 2017 12:28 P.M. UTC	FRENECTOMY CONSENT: EMAIL_VIEWED BY:ECHOSIGN			
FRIDAY, MARCH 3, 2017 12:28 P.M. UTC	FRENECTOMY CONSENT: EMAIL_VIEWED BY:ECHOSIGN			
THURSDAY, MARCH 2, 2017 10:15 P.M. UTC	STATUS CHANGED FROM SETUP IN PROGRESS TO SETUP READY FOR REVIEW BY: *****@***			
THURSDAY, MARCH 2, 2017 10:14 P.M. UTC	NATHAN CRUTCH NEW SMILE PLAN REVISION UPLOADED BY:***@***			
THURSDAY, MARCH 2, 2017 4:07 P.M. UTC	TREATMENT PLAN REVISION REQUESTED BY: *****	ALL		
THURSDAY, MARCH 2, 2017 4:07 P.M. UTC	STATUS CHANGED FROM SETUP READY FOR REVIEW TO SETUP IN PROGRESS BY: *****			
THURSDAY, MARCH 2, 2017 3:35 P.M. UTC	STATUS CHANGED FROM SECOND OPINION (TREATMENT PLAN REJECTED) TO SETUP READY FOR REVIEW BY: *****@***			
THURSDAY, MARCH 2, 2017 3:35 P.M. UTC	CASE SUBMITTED TO ***** BY: *****@***			
THURSDAY, MARCH 2, 2017 3:35 P.M. UTC	FRENECTOMY CONSENT: SIGNATURE_REQUESTED BY:ECHOSIGN			
THURSDAY, MARCH 2, 2017 3:35 P.M. UTC	FRENECTOMY CONSENT: CREATED BY:ECHOSIGN			
THURSDAY, MARCH 2, 2017 2:36 P.M. UTC	TREATMENT PLAN REJECTED BY:*****	ALL		
THURSDAY, MARCH 2, 2017 2:36 P.M. UTC	STATUS CHANGED FROM SETUP READY FOR REVIEW TO SECOND OPINION (TREATMENT PLAN REJECTED) BY: *****			
THURSDAY, MARCH 2, 2017 12:31 P.M. UTC	HYGIENIST RECOMMENDATION:APPROVE (WAITING ON OFFICAL RESPONSE FROM DOCTOR) BY:*****@***	ALL		
THURSDAY, MARCH 2, 2017 2:45 A.M. UTC	STATUS CHANGED FROM SETUP IN PROGRESS TO SETUP READY FOR REVIEW BY: *****@***			

FIG. 34C

2314

SUBMIT JOURNAL ENTRY

NOTES

AUDIENCE

STAFF

SUBMIT

2300

FIG. 34D

2300

2316

ALL CASE MESSAGES	
<p>TREATMENT PLAN REVISION 1 CREATED BY ***** ON 03-12-17 2:45AM</p>	<p>NASHVILLE, TN37219</p> <p style="text-align: right;">REPLY</p>
<p>***** FROM: PROV TO: 03-02-17 10:15PM DATE: LAB ID: CAT734723 CASE: CFA5D9990BD4D2 PATIENT: ***** MRN: M269FA0A8B9A23</p>	<p>YOUR REVISION REQUEST HAS BEEN COMPLETED, PLEASE REVIEW THE NEW TREATMENT PLAN.</p>
<p>TREATMENT PLAN REVISION 1 CREATED BY ***** ON 03-12-17 2:45AM</p>	<p>NASHVILLE, TN37219</p> <p style="text-align: right;">REPLY</p>
<p>***** FROM: SUPPORT TO: 03-02-17 2:36PM DATE: LAB ID: CAT734723 CASE: CFA5D9990BD4D2 PATIENT: ***** MRN: M269FA0A8B9A23</p>	<p>TREATMENT PLAN REJECTED. PERIODONTAL CLEARANCE NEED PERIO CLEARANCE MUST HAVE CLEANING PRIOR TO ALIGNER TREATMENT</p>
<p>***** FROM: SUPPORT TO: 03-02-17 2:36PM DATE: LAB ID: CAT734723 CASE: CFA5D9990BD4D2 PATIENT: ***** MRN: M269FA0A8B9A23</p>	<p>NEED PERIO CLEARANCE MUST HAVE CLEANING PRIOR TO ALIGNER TREATMENT.</p>
<p>***** FROM: PROV TO: 03-02-17 2:41PM DATE:</p>	<p>PLEASE NOTICE THAT SPACE WAS LEFT DISTAL FROM UPPER LATERALS, IN ORDER TO AVOID AFFECTING CANINE RELATIONSHIP.</p>

FIG. 34E

2300 ↗

2318 ↘

+				
FILES				
NAME	KIND	UPLOAD DATE	UPLOADED BY	
NEW SMILE PLAN REVISION	TREATMENTPLAN	03-02-2017 10:14PM(UTC)	*****	🗑
NEW SMILE PLAN	TREATMENTPLAN	03-02-2017 2:44AM(UTC)	*****	🗑
LOWER	3DSCAN	03-01-2017 2:16AM(UTC)	*****	🗑
UPPER	3DSCAN	03-01-2017 2:15AM(UTC)	*****	🗑
BEFORE	OTHER	02-28-2017 10:22PM(UTC)	*****	🗑
	PURCHCONSENT	02-28-2017 10:22PM(UTC)	*****	🗑
	HXCONSENT	02-28-2017 10:15PM(UTC)	*****	🗑

2320 ↘

+

 **CASE DOCUMENTS**

FRENECTOMY CONSENT
(03-02-2017 3:35PM)

VIEW DOCUMENTS

REMEMINDER

REMOVE

FIG. 34F

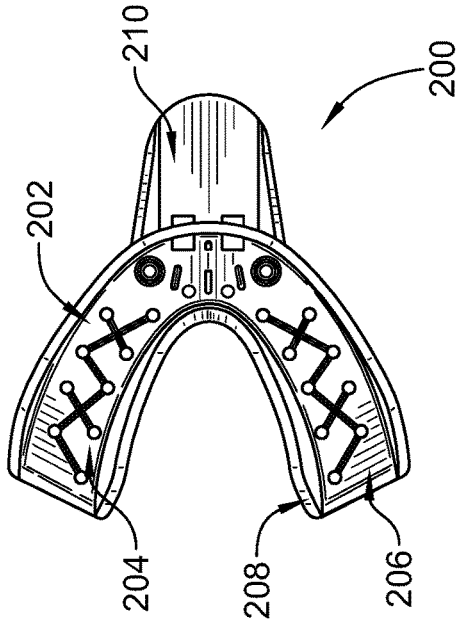

FIG. 36

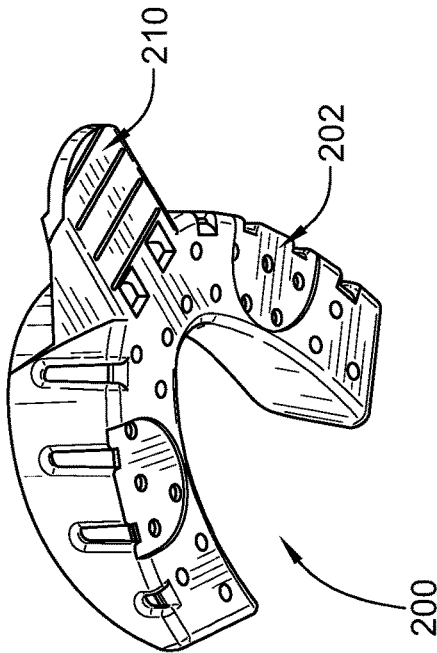

FIG. 35

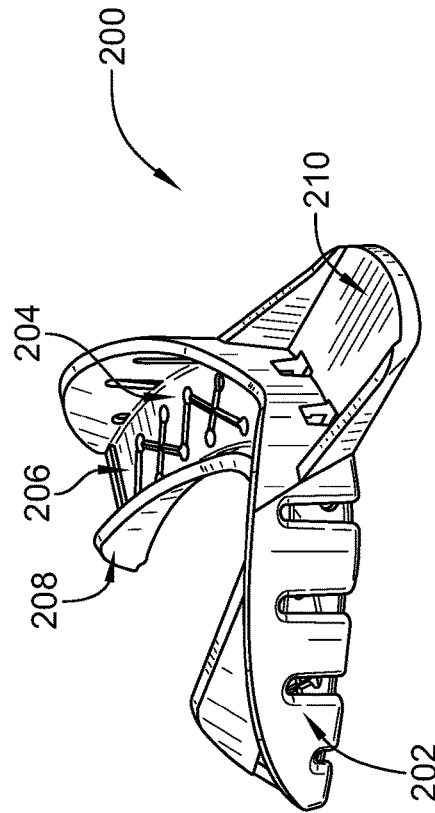

FIG. 37

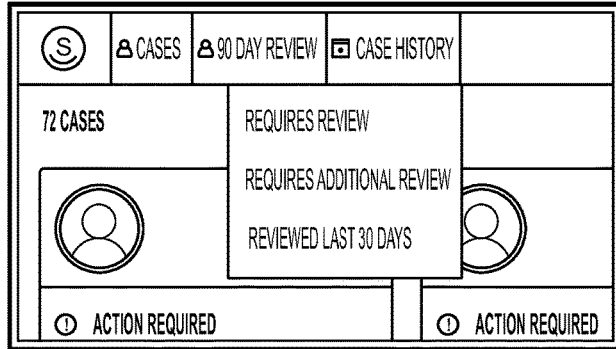

FIG. 38A

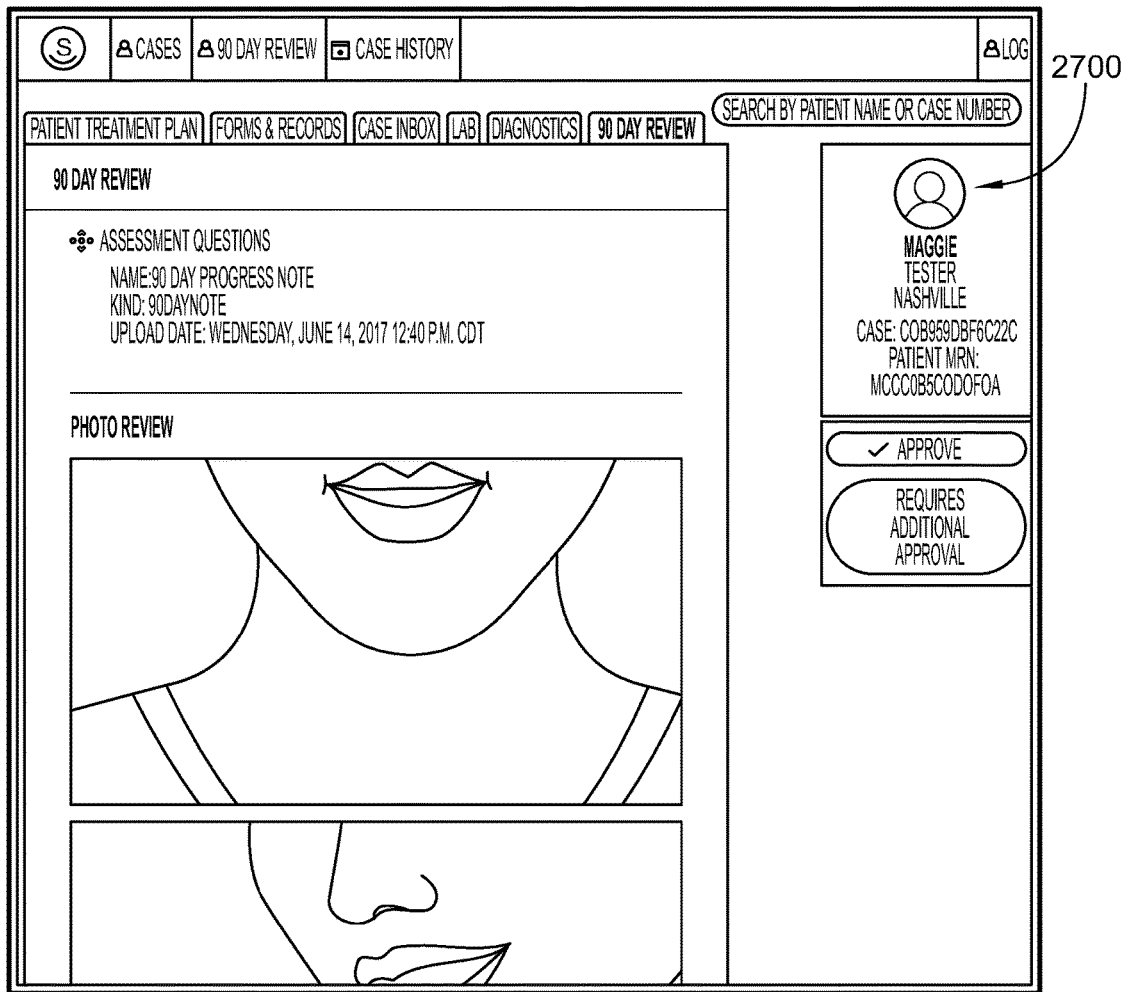

FIG. 38B

2700
↙

Navigation: (S) CASES 90 DAY REVIEW CASE HISTORY BLOG

Secondary Navigation: PATIENT TREATMENT PLAN FORMS & RECORDS CASE INBOX LAB DIAGNOSTICS 90 DAY REVIEW SEARCH BY PATIENT NAME OR CASE NUMBER

90 DAY REVIEW

ASSESSMENT QUESTIONS

NAME: 90 DAY PROGRESS NOTE
KIND: 90DAYNOTE
UPLOAD DATE: WEDNESDAY, JUNE 14, 2017 12:40 P.M. CDT

PHOTO REVIEW

USER: MAGGIE TESTER, NASHVILLE
CASE: COB0930DBF6C22C
PATIENT MRN: MCCC085C0D0FOA







APPROVE

REQUIRES MID-COURSE CORRECTION

FIG. 38C

2700



FILES				
NAME	KIND	UPLOAD DATE	UPLOADED BY	
90 DAY PROGRESS NOTE	90DAYNOTE	06-14-2017 5:40 PM (UTC)	ERMINIA SARLEY	
90 DAY PROGRESS PHOTO	90DAYPHOTO	06-14-2017 5:39 PM (UTC)	ERMINIA SARLEY	
UPPER	3DSCAN	02-18-2017 4:54 PM (UTC)	F792D1AFBO@399DCE4753.COM	
LOWER	3DSCAN	02-18-2017 4:53 PM (UTC)	F792D1AFBO@399DCE4753.COM	
LOWER	3DSCAN	02-20-2017 3:54 PM (UTC)	F792D1AFBO@399DCE4753.COM	
UPPER	3DSCAN	02-20-2017 3:57 PM (UTC)	F792D1AFBO@399DCE4753.COM	

90 DAY REVIEW

SEND 90 DAY REVIEW TO PROVIDER PORTAL

DATE SENT	SENT BY	STATUS
WEDNESDAY, JUNE 14, 2017 5:41 P.M. UTC	***@***	READY

FIG. 38D

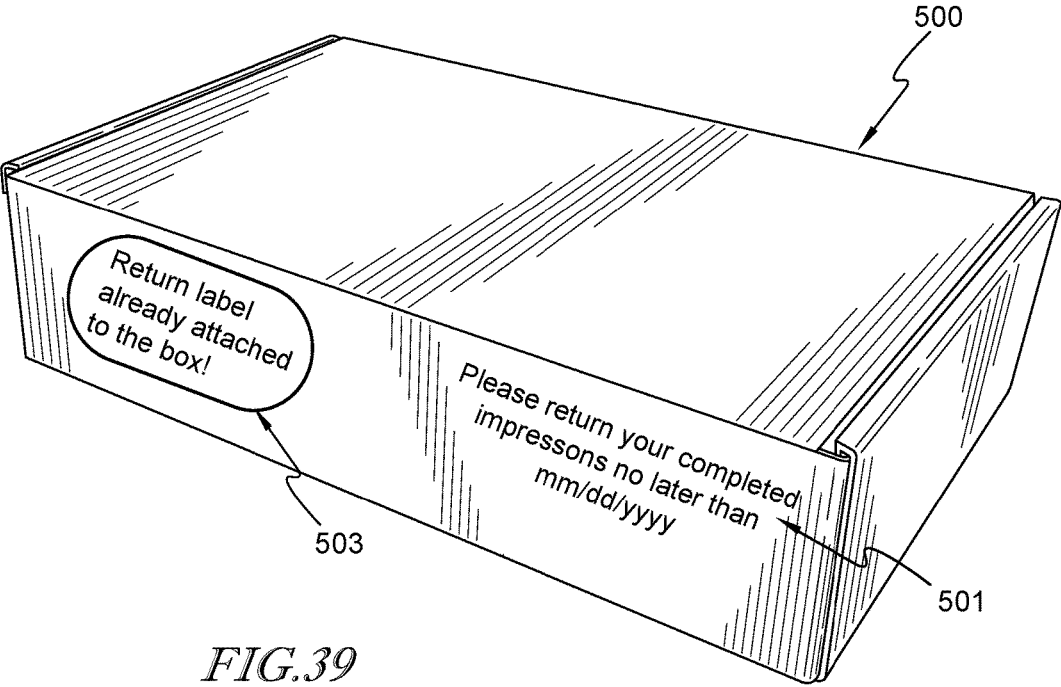

FIG. 39

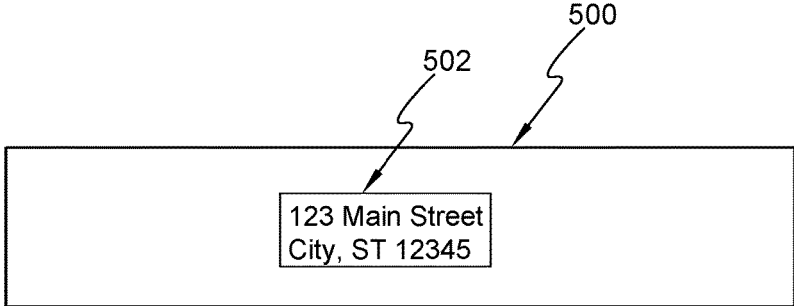

FIG. 40

DENTAL IMPRESSION KIT AND METHODS THEREFOR

CROSS-REFERENCE TO RELATED PATENT APPLICATIONS

[0001] This application claims the benefit of and priority to U.S. Provisional Patent Application No. 62/663,725, filed Apr. 27, 2018, and U.S. Provisional Patent Application No. 62/648,229, filed Mar. 26, 2018. This application is also a continuation-in-part of U.S. patent application Ser. No. 15/725,430, filed Oct. 5, 2017, which claims the benefit of and priority to U.S. Provisional Patent Application No. 62/522,847, filed Jun. 21, 2017. All of the aforementioned applications are incorporated herein by reference in their entirety.

TECHNICAL FIELD

[0002] The present disclosure relates to a dental impression kit and, more specifically, to a system and method for application of a dental impression kit at home. The present disclosure also relates to an application server for remote orthodontic treatment and methods therefor.

BACKGROUND

[0003] A dental impression provides a negative imprint of the teeth and tissues in the mouth. The negative impression may then be utilized to produce a physical or digital reproduction of the teeth, e.g. dentures and orthodontics. Generally, a dental tray having a viscous, thixotropic impression material therein is fit over the dental arches of the patient. The impression material sets to a solid leaving an imprint of the structures in the mouth. When removed from the mouth, the impression provides a detailed and stable negative of the teeth. Optionally, the impression is processed using digital scanning methods to create the digital negative of the teeth.

[0004] Traditionally, dental impressions are made in a dental office and require significant time. The impressions are then delivered to an outside vendor that utilizes the impression to form a positive model of the teeth. If the dental impression includes any errors, e.g. incomplete impression of the teeth and tissues, the patient may be required to return to the dental office to have a second impression made.

[0005] As an alternative method to traditional orthodontic procedures, in less severe cases, dental impressions may be made with an at-home dental impression kit. Such kits are generally prescribed by a dental professional to qualified customers, e.g. in a dental office. The user may then administer the contents of the dental impression kit at home. After completing the dental impressions, the kit is returned to the dental professional. Some at-home kits may be difficult to administer and/or may result in poor quality dental impressions.

SUMMARY

[0006] According to one aspect of the disclosure, a method of administering the contents of a dental impression kit is disclosed. The method includes sending a dental impression kit to a user, the dental impression kit including a container having a top layer containing an initial dental assembly and a bottom layer containing a redundant dental assembly. The bottom layer is positioned below the top layer. The dental impression kit has instructions for administering the initial dental assembly, administering the redun-

dant dental assembly, and returning the administered initial dental assembly and the administered redundant dental assembly. The instructions include an initial instruction, a redundant instruction, and a return instruction. The instructions include instructing the user to administer the initial dental assembly according to the initial instruction. The instructions include instructing the user to remove the top layer from the container to expose the bottom layer. The instructions include instructing the user to administer the redundant dental assembly according to the redundant instruction. The instructions include instructing the user to return the initial dental assembly and the redundant dental assembly within a predetermined time frame.

[0007] In some embodiments, instructing the user to return the initial dental assembly and the redundant dental assembly within the predetermined time frame includes instructing the user to return the initial dental assembly and the redundant dental assembly within the predetermined time frame from a date upon which the user ordered the dental impression kit.

[0008] In some embodiments, instructing the user to return the initial dental assembly and the redundant dental assembly within the predetermined time frame includes instructing the user to return the initial dental assembly and the redundant dental assembly within the predetermined time frame from a date upon which the dental impression kit was sent to the user.

[0009] In some embodiments, instructing the user to return the initial dental assembly and the redundant dental assembly within the predetermined time frame includes instructing the user to return the initial dental assembly and the redundant dental assembly within the predetermined time frame from a date upon which the user is estimated to receive the dental impression kit.

[0010] In some embodiments, the predetermined time frame is two weeks.

[0011] In some embodiments, the dental impression kit further includes a container for returning the initial dental assembly and the redundant dental assembly. The shipping container can include a return mailing label.

[0012] In some embodiments, the dental impression kit is shipped in a container. The container for returning the initial dental assembly and the redundant dental assembly and the container in which the dental impression kit are the same container.

[0013] In some embodiments, the predetermined time frame is represented on a label positioned on the container.

[0014] According to another aspect of the disclosure, a dental impression kit is disclosed. The dental impression kit includes a container having a top layer containing an initial dental assembly and a bottom layer containing a redundant dental assembly. The bottom layer is positioned below the top layer. The dental impression kit further includes instructions instructing a user to administer the initial dental assembly according to an initial instruction. The dental impression kit further includes instructions instructing a user to remove the top layer from the container to expose the bottom layer. The dental impression kit further includes instructions instructing a user to administer the redundant dental assembly according to a redundant instruction. The dental impression kit further includes instructions instructing a user to return the initial dental assembly and the redundant dental assembly within a predetermined time frame.

[0015] In some embodiments, instructing the user to return the initial dental assembly and the redundant dental assembly within the predetermined time frame includes instructing the user to return the initial dental assembly and the redundant dental assembly within the predetermined time frame from a date upon which the user ordered the dental impression kit.

[0016] In some embodiments, instructing the user to return the initial dental assembly and the redundant dental assembly within the predetermined time frame includes instructing the user to return the initial dental assembly and the redundant dental assembly within the predetermined time frame from a date upon which the dental impression kit was sent to the user.

[0017] In some embodiments, instructing the user to return the initial dental assembly and the redundant dental assembly within the predetermined time frame includes instructing the user to return the initial dental assembly and the redundant dental assembly within the predetermined time frame from a date upon which the user is estimated to receive the dental impression kit.

[0018] In some embodiments, the predetermined time frame is two weeks.

[0019] In some embodiments, the dental impression kit further includes a container for returning the initial dental assembly and the redundant dental assembly. The shipping container may include a return mailing label and a label including the predetermined time frame.

[0020] According to another aspect of the disclosure, a dental impression kit is disclosed. The dental impression kit includes a dental assembly including a dental tray, a base putty, and a catalyst putty, the base putty and the catalyst putty being mixable to form a putty mixture to be positioned in the dental tray. The dental impression kit further includes instructions instructing a user to mix the base putty and the catalyst putty to form the putty mixture. The dental impression kit further includes instructions instructing a user to position the putty mixture in the dental tray. The dental impression kit further includes instructions instructing a user to administer the dental tray. The dental impression kit further includes instructions instructing a user to return the administered dental tray within a predetermined time frame.

[0021] In some embodiments, instructing the user to return the administered dental tray within the predetermined time frame includes instructing the user to return the administered dental tray within the predetermined time frame from a date upon which the user ordered the dental impression kit.

[0022] In some embodiments, instructing the user to return the administered dental tray within the predetermined time frame includes instructing the user to return the administered dental tray within the predetermined time frame from a date upon which the dental impression kit was sent to the user.

[0023] In some embodiments, instructing the user to return the administered dental tray within the predetermined time frame includes instructing the user to return the administered dental tray within the predetermined time frame from a date upon which the user is estimated to receive the dental impression kit.

[0024] In some embodiments, the dental impression kit further includes a shipping container for returning the initial dental assembly and the redundant dental assembly. The shipping container may include a return mailing label.

[0025] In some embodiments, the predetermined time frame is represented on a label.

BRIEF DESCRIPTION OF THE DRAWINGS

[0026] The foregoing and other features of the various embodiments of the methods and apparatuses described herein will become more apparent from the following detailed description and the accompanying drawings in which:

[0027] FIG. 1 is a perspective view of a container that contains the contents of a dental impression kit;

[0028] FIG. 2 is a perspective view of an insert that is positioned within the container shown in FIG. 1;

[0029] FIG. 3 is a perspective view of the container shown in FIG. 1 in an open configuration to expose an instruction manual;

[0030] FIG. 4 is a perspective view of a top layer of the insert shown in FIG. 2 and having part of the dental impression kit therein;

[0031] FIG. 5 is a perspective view of a bottom layer of the insert shown in FIG. 2 and having part of the dental impression kit therein;

[0032] FIG. 6 is a perspective view of a bottom of the container shown in FIG. 1 and having part of the dental impression kit therein;

[0033] FIG. 7 is a perspective view of part of the dental impression kit including dental trays, base putty containers, and catalyst putty containers;

[0034] FIG. 8 is a perspective view of a dental appliance that is included in the dental impression kit;

[0035] FIG. 9 is a perspective view of gloves that are included in the dental impression kit;

[0036] FIG. 10 is a flowchart of a method for administering the dental impression kit shown in FIGS. 1-9;

[0037] FIG. 11 is a perspective view of another container that contains the contents of a dental impression kit;

[0038] FIG. 12 is a perspective view of the container shown in FIG. 11 opened;

[0039] FIG. 13 is a perspective view of an initial dental assembly insert that is positioned within the container shown in FIG. 11;

[0040] FIG. 14 is a perspective view of another initial dental assembly insert that is positioned within the container shown in FIG. 11;

[0041] FIG. 15 is a perspective view of a redundant dental assembly insert that is positioned within the container shown in FIG. 11;

[0042] FIG. 16 is a perspective view of another redundant dental assembly insert that is positioned within the container shown in FIG. 11;

[0043] FIG. 17 is a perspective view of a dental appliance insert that is positioned within the container shown in FIG. 11;

[0044] FIG. 18 is a perspective view of a dental aligner kit having a top insert;

[0045] FIG. 19 is a plan view of a dental tool kit of the dental aligner kit shown in FIG. 18;

[0046] FIG. 20 is a perspective view of first lower inserts of the dental aligner kit shown in FIG. 18;

[0047] FIG. 21 is a perspective view of second lower inserts of the dental aligner kit shown in FIG. 18;

[0048] FIG. 22 is a simplified block diagram of at least one embodiment of a system for remote orthodontic treatment and assessment;

[0049] FIG. 23 is a simplified block diagram of at least one embodiment of an environment that may be established by an application server of FIG. 22;

[0050] FIGS. 24A and 24B are a simplified flow diagram of at least one embodiment of a method for remote orthodontic treatment and assessment that may be executed by the application server of FIGS. 22-23;

[0051] FIG. 25 is a simplified flow diagram of at least one embodiment of a method for 3D model optimization that may be executed by the application server of FIGS. 22-23;

[0052] FIG. 26 is a screen shot of a smile assessment user interface that may be generated by the application server of FIGS. 22-23;

[0053] FIG. 27 is a screen shot of an account status user interface that may be generated by the application server of FIGS. 22-23;

[0054] FIGS. 28A-28C are screen shots of an image upload user interface that may be generated by the application server of FIGS. 22-23;

[0055] FIGS. 29A-29E are screen shots of a dental history questionnaire user interface that may be generated by the application server of FIGS. 22-23;

[0056] FIGS. 30A and 30B are screen shots of a photo assessment user interface that may be generated by the application server of FIGS. 22-23;

[0057] FIGS. 31A-31E are screen shots of a provider portal user interface that may be generated by the application server of FIGS. 22-23;

[0058] FIG. 32 is a screen shot of an account status user interface that may be generated by the application server of FIGS. 22-23;

[0059] FIG. 33 is a screen shot of a 3D treatment plan viewer user interface that may be generated by the application server of FIGS. 22-23;

[0060] FIGS. 34A-34F are screen shots of a staff portal user interface that may be generated by the application server of FIGS. 22-23;

[0061] FIGS. 35-37 are views of another embodiment of a dental tray;

[0062] FIGS. 38A-38D are screen shots of a check-in process user interface that may be generated by the application server of FIGS. 22-23; and

[0063] FIGS. 39 and 40 are views of a container containing the contents of a dental impression kit according to another exemplary embodiment.

DETAILED DESCRIPTION OF THE DRAWINGS

[0064] While the concepts of the present disclosure are susceptible to various modifications and alternative forms, specific exemplary embodiments thereof have been illustrated by way of example in the drawings and will herein be described in detail. It should be understood, however, that there is no intent to limit the concepts of the present disclosure to the particular forms disclosed, but on the contrary, the intention is to cover all modifications, equivalents, and alternatives falling within the spirit and scope of the invention as defined by the appended claims.

[0065] Referring to FIG. 1, a dental impression kit 10 is shown having dental assemblies (discussed in more detail below) therein. The dental impression kit 10 may be ordered by a customer and shipped in a container or box 12, shown in FIG. 1, from a vendor. After administering the dental impression kit 10 at home, the customer may ship the dental impression kit 10 in the box 12 back to the vendor for analysis. The box 12 is sized for standard shipping and is likewise sized for delivery into the customer's mailbox.

Accordingly, additional fees for shipment of the dental impression kit 10 in the box 12 may not be required.

[0066] Referring to FIG. 2, the box 12 includes an insert 14 therein that is configured to retain the dental assemblies. The insert 14 includes a top layer 16 having a plurality of cutouts formed therein. A front cutout 18 is sized and shaped to receive a user's finger to lift the top layer 16 from the box 12. A pair of tray cutouts 20 are sized and shaped to retain dental trays (described below). The tray cutouts 20 include a flange 22 that is sized and shaped to retain a front flange of the dental tray. A pair of flanges 24 retain rear ends of the dental tray. Circular cutouts 26 are sized and shaped to retain containers of putty (described below).

[0067] A front flap 28 is joined to the top layer 16 along a fold line 30. The front flap 28 is configured to be folded such that an end 32 of the front flap 28 engages a bottom of the box 12, when the insert 14 is positioned within the box 12. The front flap 28 supports the top layer 16 within the box 12. A center flap 34 extends from the top layer 16 along a fold line 36. The center flap 34 is also connected to a second or bottom layer 38 along a fold line 40. When the insert 14 is positioned within the box 12, the center flap 34 supports the top layer 16 within the box.

[0068] The bottom layer 38 is configured to be positioned below the top layer 16, when the insert 14 is positioned within the box 12. The bottom layer 38 also includes a plurality of cutouts formed therein. A pair of tray cutouts 20 are sized and shaped to retain dental trays. The tray cutouts 20 include a flange 22 that is sized and shaped to retain a front flange of the dental tray. A pair of flanges 24 retain rear ends of the dental tray. Circular cutouts 26 are sized and shaped to retain containers of putty.

[0069] A front flap 42 extends from the bottom layer 38 along a fold line 44. The front flap 42 is configured to be folded such that an end 46 of the front flap 42 engages a bottom of the box 12, when the insert 14 is positioned within the box 12. A pair of side flaps 48 extends from the bottom layer 38 along fold lines 50. The side flaps 48 are configured to be folded such that an end 52 of each side flap 48 engages a bottom of the box 12, when the insert 14 is positioned within the box 12. Accordingly, the front flap 42 and the side flaps 48 support the bottom layer 38 within the box 12, when the insert 14 is positioned within the box 12.

[0070] In some embodiments, the top layer 16 and the bottom layer 38 are not integrally formed. In such an embodiment, the top layer 16 is configured to be positioned on top of the bottom layer 38 such that the top layer is individually removable while the bottom layer 38 remains within the box 12.

[0071] Referring to FIG. 3, when the box 12 is opened, an instruction manual 54 is positioned at a top of the box contents. The instruction manual 54 provides step-by-step instructions for administering the contents of the dental impression kit 10. A method for administering the dental impression kit 10 according to the instructions is described in more detail with respect to FIG. 10. In some embodiments, the user may be provided with an impression kit video. Similar to the instructions, the video may instruct the user on how to properly administer an impression. The instructor may be a dental professional, such as a dentist, orthodontist, dental hygienist, etc. The impression kit video may be sent to the user (e.g., via email) on the date of ordering the dental impression kit 10, on the date of receipt, etc. Additionally, a link to the impression kit video may be

provided on the box 12 and the user may be instructed to go to the link and watch the video. Such embodiments may increase the likelihood of acceptance of the impressions, as will be discussed in greater detail below.

[0072] Referring to FIG. 4, when the instruction manual 54 is removed from the box 12, the top layer 16 of the insert 14 is exposed. The top layer 16 includes the contents of an initial dental assembly 56. Referring to FIG. 7, the initial dental assembly 56 includes two initial dental trays 58, two containers of an initial base putty 60, and two containers of an initial catalyst putty 62. The instruction manual 54 includes initial instructions for administering the initial dental assembly 56. Generally, in use, a container of initial base putty 60 is mixed with a container of initial catalyst putty 62 to form a putty mixture. The putty mixture is then positioned in one of the initial dental trays 58 to form a dental impression of the upper teeth. The second container of initial base putty 60 is then mixed with the second container of initial catalyst putty 62 to form another putty mixture that is positioned in the second initial dental tray 58 to form a dental impression of the lower teeth. This process is explained in more detail below with respect to FIG. 10.

[0073] The contents of the box 12 may be stored prior to shipment of the user. For instance, the box 12 and all putty (e.g., the initial base and catalyst putty 60, 62 described above, the redundant base and catalyst putty 61, 63 described below, etc.) may be stored in a temperature controlled environment (e.g., no greater than 77° f, for instance). Additionally the contents of the box 12 may be handled in a clean environment (e.g., on stainless steel work surfaces which are cleaned on a daily basis, in a clean space free of debris, particulates and allergens, putty and other contents only handled with gloves on, etc.). In these embodiments, the contents of the box 12 may have an increased quality. Additionally, each of the contents of the box 12 may include lot numbers for tracking the materials. Such lot numbers may be used for quality control purposes. Following the box 12 being assembled, the box 12 may be shipped out with the contents.

[0074] In some embodiments, the box 12 may include a plurality of different dental trays 58. For instance, the box 12 may include small, medium, and large sized dental trays 58. The user may place each of the different sized dental trays 58 in their mouth to determine the proper size (e.g., based on which size best fits the user's teeth). The user may then administer the impression using the proper size dental trays 58. In some embodiments, the box 12 may include upper dental arch specific and lower dental arch specific dental trays 58 of different sizes. For instance, the upper dental arch specific dental trays 58 may be shaped to substantially match the shape of an upper dental arch of a person (e.g., the user). Additionally, the lower dental arch specific dental trays 58 may be shaped to substantially match the shape of a lower dental arch of a person (e.g., the user). Using dental trays more particularly sized and shaped for a user's own personal dental arch may increase the likelihood of an acceptable dental impression.

[0075] In some embodiments, the box 12 may only include specific dental trays 58. For instance, the box 12 may include only upper dental arch impression trays 58 or lower dental arch impression trays 58. The box 12 may include upper dental arch impression trays 58 where the user previously submitted dental impressions and had upper dental impressions rejected. The box 12 may include lower dental

arch impression trays 58 where the user previously submitted dental impressions and had lower dental impressions rejected. In embodiments such as these, the user may only be required to obtain one of an upper or a lower impression, rather than both upper and lower impressions. Additionally, in embodiments such as these, the user may be provided less base and catalyst putty than standard impression kits (e.g., such as only enough base and catalyst putty for taking one upper or one lower impression, only enough base and catalyst putty for taking two upper or two lower impressions, etc.).

[0076] In some embodiments, the user may order a retake kit including, for instance, upper and/or lower impression kits. For instance, the user may call the vendor to order these retake kits when their previous impressions were rejected. Additionally or alternatively, the user may provide log-in information to a website or web page for ordering retake kits. When the user logs onto their account and the user's file indicates that the user had a previously-rejected impression, the corresponding retake kit may automatically be ordered. As one example, the user may have previously had upper impressions rejected, but lower impressions accepted, which is indicated in a file associated with the user's account. The user may log into their account on a website or web page. Upon logging into their account, the upper impression retake kit may automatically be ordered, since the file associated with the user's account indicates that the upper impressions were previously rejected. In some embodiments, the user may log onto the website or web page to order the retake kit following receipt of a kit rejection message. The kit rejection message may be an email (or other message via a communications medium) which indicates that one or more of their impressions were rejected. In some embodiments, the kit rejection message may include a personalized message which indicates why their previous impression was rejected (e.g., didn't bite down properly, the impression moved, etc.). The kit rejection message may include instructions on how to improve their subsequent impression(s) in the retake kit based on their previous rejection (e.g., bite down, keep the impression tray still, etc.). Such embodiments may increase the likelihood of impression acceptance and increase the likelihood of the user returning the contents of the retake impression kit.

[0077] In some embodiments, the user may be notified that they are receiving a VIP retake impression kit via express mail, as opposed to standard mail. Additionally, in some embodiments, the VIP retake impression kit may include one or more additional promotional items located therein (e.g., lip balm, tote bag, etc.). In these embodiments, users may be more likely to continue the process and order aligners despite having to retake an impression.

[0078] In some embodiments, the retake kit may be free. For instance, where the user previously selected an option to automatically generate aligners upon their impressions being approved by the dental professional (e.g., a fast track option), the retake kit may be free. Such embodiments may further incentivize users to select the fast track option, which may eliminate bottlenecks in the aligner production process. In some embodiments, the retake kit may include a fast track form for opting into the fast track option. For instance, the fast track form may be included in a retake kit where the user has not previously opted into the fast track option. However, where a user previously opted into a fast track option, the fast track form may be foregone. In these embodiments,

users may be more likely to opt into the fast track option, thus eliminating further bottlenecks in the aligner production process.

[0079] In some embodiments, the dental impression kit **10** and/or the retake kits may include ambassador program information and/or referral information. Such information may include various incentives which are available to the user if the user becomes a brand ambassador or makes any referrals. Such embodiments may highlight the benefits to the user, thus increasing the likelihood of the user promoting the process.

[0080] Still referring to FIG. 7, the initial dental trays **58** include a substantially arched mouth insert **64** that is sized and shaped to be inserted into the user's mouth. Particularly, the insert **64** is sized and shaped to be received into either an upper portion or a lower portion of the user's mouth. The insert **64** includes a cavity **66** defined by a bottom wall **68** and a pair of sidewalls **70** extending upward from the bottom wall **68**. The cavity **66** is sized to receive the putty mixture. When the initial dental tray **58** is inserted into the user's mouth, the user bites down on the initial dental tray **58** so that the user's teeth are within the cavity **66** and bite into the putty mixture. A flange **72** extends from a front of the initial dental tray **58**. The flange **72** is configured to be gripped by the user to insert and remove the initial dental tray **58** from the user's mouth.

[0081] In some embodiments, the initial catalyst putty **62** is a polyvinyl siloxane that provides a predetermined period of time to set when mixed with the initial base putty **60**. The predetermined period of time is based on a period of time necessary for a user to administer the dental impression kit **10** at home. That is, the predetermined period of time is selected to allow the user enough time to prepare the putty mixture and dental impression, while also preventing the putty mixture from deforming when the initial dental tray **58** having the putty mixture therein is removed from the user's mouth. In some embodiments, the initial base putty **60** and the initial catalyst putty **62** may be required to be at room temperature before mixing.

[0082] In some embodiments, the user may be provided a predetermined amount of base and catalyst putty. The user may be provided an amount of base and catalyst putty that lessens the likelihood of the putty mixture overflowing the dental impression. Additionally, the user may be provided an amount of base and catalyst putty that is sufficient for capturing an acceptable dental impression by the user. For instance, the user may be provided an amount of base and catalyst putty that, when the putty mixture is prepared and placed in the dental tray **58**, enough putty mixture is in the dental tray **58** to sufficiently capture a dental impression. The predetermined amount of base and catalyst putty may be provided in corresponding cups, as shown. In some embodiments, the predetermined amounts of base and catalyst putty may be in the range of 0.5 oz. to 1.5 oz. In some embodiments, the predetermined amounts of base and catalyst putty may be in the range of 0.88 oz. and 0.90 oz. In some embodiments, the predetermined amount of base putty may be approximately 0.9 oz., and the predetermined amount of catalyst putty may be approximately 0.88 oz. (e.g., more base putty than catalyst putty). In still other embodiments, the predetermined amount of base putty may be approximately 0.88 oz., and the predetermined amount of catalyst putty may be approximately 0.90 oz. (e.g., more catalyst putty than base putty). In still other embodiments, the

predetermined amount of base putty may be substantially the same as the predetermined amount of catalyst putty. In each of these embodiments, the corresponding cups may be sealed. For example, the cups may be thermosealed with a plastic film, sealed with a foil and glue, sealed with a cap that is screwed or snapped onto the cup, hermetically sealed, etc.

[0083] In some embodiments, the base and catalyst putty may be premixed and loaded in the dental trays provided in a corresponding dental assembly **56**, **74**. For instance, the putty mixture may be stable (e.g., will not harden prior to administering the dental impressions). The stable putty mixture may be loaded in the dental trays such that the user does not need to mix the base and catalyst putties. The dental trays with the stable putty mixture may be sealed (e.g., in a manner similar to the methods of sealing the cups described above). The user can then remove the seal and administer the dental trays. Such embodiments may ease the user experience by removing the need for mixing the putties and placing the mixed putties into the dental trays. Further, such embodiments may increase the likelihood of acceptance of the impressions as the dental trays and putty mixtures may be more consistent, resulting in more consistent and better quality impressions.

[0084] Referring back to FIG. 4, after the initial dental assembly **56** is used to form an initial set of dental impressions of both the upper and lower teeth, the user may grip the top layer **16** by the front cutout **18** and lift the top layer **16** from the box **12**. Specifically, the top layer **16** folds back along the fold line **36** to expose the bottom layer **38**.

[0085] FIG. 5 shows, the top layer **16** folded back to expose the bottom layer **38**. Notably, the top layer **16** is still connected to the bottom layer **38** by the center flap **34**; however, the top layer **16** is folded back so that the bottom layer **38** may be accessed. The bottom layer **38** includes a redundant dental assembly **74**. The redundant dental assembly **74** is identical to the initial dental assembly **56**, described with respect to FIG. 7, and includes two redundant dental trays **59** that are identical to the initial dental trays **58** described with respect to FIG. 7, two containers of a redundant base putty **61** that are identical to the containers of initial base putty **60** described with respect to FIG. 7, and two containers of a redundant catalyst putty **63** that are identical to the containers of initial catalyst putty described with respect to FIG. 7. The instruction manual **54** includes redundant instructions for administering the redundant dental assembly **74**. The redundant dental assembly **74** is utilized to form a second set of dental impressions of the upper and lower teeth (as described below). Accordingly, the redundant dental assembly **74** provides redundancy in administering the dental impression kit **10**. This redundancy enables the user to "practice" forming the dental impression with the initial dental assembly **56**. Alternatively or in addition to, the redundancy provides for two sets of dental impressions if one of the impressions is not properly achieved.

[0086] Referring to FIG. 6, a pair of gloves **76** and a dental appliance **78** are included at a bottom **80** of the box **12**. Particularly, the pair of gloves **76** and the dental appliance **78** are positioned below the insert **14**. When opening the dental impression kit **10**, the user may first remove the instruction manual **54** and the insert **14** to gain access to the pair of gloves **76** and the dental appliance **78**. The insert **14** may then be positioned back into the box so that the user

may appropriately follow the instructions in the instruction manual 54, as described in more detail below.

[0087] Referring to FIG. 8, the dental appliance 78 includes a handle 82 having a pair of flanges 84 at each end. The flanges 84 are generally U-shaped and form a cavity 86. The instruction manual 54 includes appliance instructions for utilizing the dental appliance 78. The cavity 86 is configured to receive the user's lips at the sides of the user's mouth. The dental appliance 78 is configured to separate the user's lips to open the user's mouth. In this position, the user may photograph his/her teeth, as described in more detail below. In some embodiments, the dental appliance 78 may be positioned in a resealable (or otherwise reusable) bag. The dental appliance 78 may then be maintained by the user for both initial and subsequent photos of his/her teeth. The subsequent photos may be substantially the same types of photos as the initial photos, but are captured a duration (for instance, 90 days) into the treatment process.

[0088] FIG. 9 shows the pair of gloves 76. In some embodiments, the gloves 76 are formed from a non-latex, hypo-allergenic material. The gloves 76 may also be sized and stretchable for any user's hands. The gloves 76 are used to protect the user's hands from the initial base putty 60 and the initial catalyst putty 62. The gloves 76 also prevent contamination of the initial base putty 60 and the initial catalyst putty 62.

[0089] Referring to FIG. 10, a method 100 for administering the dental impression kit 10 includes receiving from a vendor the dental impression kit 10 in the box 12 in the mail. The box 12 is opened so that the user may obtain the instruction manual 54 for the dental impression kit 10. After removing the instruction manual 54, the entire insert 14 may be removed to expose the gloves 76 and the dental appliance 78. After the gloves 76 and dental appliance 78 are removed from the box 12, the insert 14 is positioned back into the box 12 so that the instruction manual 54 may be properly followed. The user is instructed to wash his/her hands and put the gloves 76 on before proceeding.

[0090] With the insert 14 positioned back into the box 12, the top layer 16 is exposed. The initial dental assembly 56 is then administered, at step 102, by following the initial instruction of the instruction manual 54. At step 104, the initial base putty 60 is mixed with the initial catalyst putty 62 to form an initial putty mixture. In some embodiments, the initial base putty 60 and the initial catalyst putty 62 may be referred to in the instruction manual 54 by their colors (as opposed to base and catalyst putty 60, 62). In these embodiments, the instruction manual 54 may be easier to follow by the user. Accordingly, the initial instruction of the instruction manual 54 may instruct the user to mix the purple putty with the gray putty, for instance.

[0091] In some embodiments, the initial base putty 60 is mixed with the initial catalyst putty 62 for approximately 20 seconds to form the initial putty mixture. In other embodiments, the initial base putty 60 is mixed with the initial catalyst putty 62 for a time period to reach a proper temperature as required by the putty type and/or environmental conditions. For example, the mixing time may vary based on geographical region or the time of year, e.g. summer or winter, humidity and temperature dependent environment (e.g., both interior temperature and/or exterior temperature). At step 106, the initial putty mixture is then positioned within the cavity 66 of the initial dental tray 58. In some embodiments, the user is instructed to position the

initial putty mixture within the cavity 66 of the initial dental tray 58 within a time frame of approximately less than or equal to one minute from the time the initial base putty and 60 the initial catalyst putty 62 are opened. In other embodiments, the initial putty mixture is positioned within the cavity 66 of the initial dental tray 58 within a time period required by the putty type and/or environmental conditions. For example, the time may vary based on geographical region or the time of year, e.g. summer or winter. With the initial putty mixture positioned within the cavity 66 of the initial dental tray 58, the user then inserts the initial dental tray 58 into his/her mouth and bites down so that the user's upper teeth are positioned within the initial putty mixture to form an initial dental impression, at step 108. In some embodiments the initial dental tray 58 is retained within the user's mouth for a time period of approximately 2.5 to 3.5 minutes to create the initial dental impression. In other embodiments, the initial dental tray 58 is retained within the user's mouth for a time period required by the putty type and/or environmental conditions. For example, the time may vary based on geographical region or the time of year, e.g. summer or winter. At step 110, steps 104-108 are repeated using the second initial dental tray 58, the second container of initial base putty 60, and the second container of initial catalyst putty 62 to form an initial dental impression of the user's lower teeth. In some embodiments, the instructions may instruct the user to administer the impression of the user's lower teeth before administering the impression of the user's upper teeth. In these embodiments, likelihood of acceptance of the impressions for generation of aligners may be increased.

[0092] After the initial set of dental impressions has been made, the user folds the top layer 16 back to expose the bottom layer 38 and the redundant dental assembly 74. The redundant dental assembly 74 is then administered, at step 112, by following the redundant instruction of the instruction manual 54. At step 114, the redundant base putty 61 is mixed with the redundant catalyst putty 63 to form a redundant putty mixture. In some embodiments, the redundant base putty 61 and the redundant catalyst putty 63 may be referred to in the instruction manual 54 by their colors (as opposed to base and catalyst putty 61, 63). In these embodiments, the instruction manual 54 may be easier to follow by the user. Accordingly, the initial instruction of the instruction manual 54 may instruct the user to mix the purple putty with the gray putty, for instance.

[0093] In some embodiments, the redundant base putty 61 is mixed with the redundant catalyst putty 63 for approximately 20 seconds to form the redundant putty mixture. In other embodiments, the redundant base putty 61 is mixed with the redundant catalyst putty 63 for a time period to reach a proper temperature as required by the putty type and/or environmental conditions. For example, the time may vary based on geographical region or the time of year, e.g. summer or winter, humidity and temperature dependent environment (e.g., both interior temperature and/or exterior temperature). The redundant putty mixture is then positioned within the cavity 66 of the redundant dental tray 59, at step 116. In some embodiments, the user is instructed to position the redundant putty mixture within the cavity 66 of the redundant dental tray 59 within a time frame of approximately less than or equal to one minute from the time the redundant base putty 61 the redundant catalyst putty 63 are opened. In other embodiments, the redundant putty mixture

is positioned within the cavity 66 of the redundant dental tray 59 within a time period required by the putty type and/or environmental conditions. For example, the time may vary based on geographical region or the time of year, e.g. summer or winter. With the redundant putty mixture positioned within the cavity 66 of the redundant dental tray 59, the user then inserts the redundant dental tray 59 into his/her mouth and bites down so that the user's upper teeth are positioned within the redundant putty mixture to form a redundant dental impression, at step 118. In some embodiments the redundant dental tray 59 is retained within the user's mouth for a time period of approximately 2.5 to 3.5 minutes to create the redundant dental impression. In other embodiments, the redundant dental tray 59 is retained within the user's mouth for a time period required by the putty type and/or environmental conditions. For example, the time may vary based on geographical region or the time of year, e.g. summer or winter. At step 120, steps 114-118 are repeated using the second redundant dental tray 59, the second container of redundant base putty 61, and the second container of redundant catalyst putty 63 to form a redundant dental impression of the user's lower teeth.

[0094] After administering the initial dental assembly 56 and the redundant dental assembly 74, the user has created two sets of dental impressions of both his/her upper teeth and his/her lower teeth. The insert 14 may be removed from the box 12 and discarded. The dental appliance 78 is then inserted into the user's mouth to separate the user's lips and expose the user's teeth, at step 122. With the dental appliance 78 in his/her mouth, the user takes a series of photos of his/her teeth in accordance with an appliance instruction in the instruction manual 54, at step 124. These photos may then be uploaded to the vendor's website via a web portal or the like, at step 126. In some embodiments, the user may receive analysis and evaluation results from a dental professional. The dental professional may access the photos via a corresponding web portal in real-time or near real-time to analyze and evaluate the results. The dental professional may evaluate the user's photos to determine whether the user's smile is suitable for treatment, whether the user's photos sufficiently capture the user's smile in the desired perspectives, etc. The dental professional may indicate that the user needs to retake one or more photos. The dental professional may send a message (e.g., a text message, an e-mail, etc.) to the user instructing the user on how to recapture a photo. Following the user uploading the photos, and optionally receiving analysis and evaluation results, the user may then position both sets of dental impressions, i.e. the upper and lower initial dental impressions from the initial dental assembly 56 and the upper and lower redundant dental impressions from the redundant dental assembly 74 into the empty box 12. It should be noted that the dental impressions are not removed from the dental trays 58, 59. That is, the dental trays 58, 59 with the dental impressions therein are positioned in the box 12. The box is then sealed with a sticker included within the dental impression kit 10. At step 128, the box 12 with the dental impressions sealed therein is mailed back to the vendor using a return mailing label that is included in (or affixed to) the dental impression kit 10.

[0095] While described as taking photos of the user's teeth following administering the dental assemblies 56 and 74, in some embodiments, the user may take additional photos of the user's teeth and/or of the dental impressions to the

vendor's website via a web portal. For instance, the user may take photos of the dental impressions (e.g., of the upper and/or the lower impressions). The user may take these photos between the user administering the initial dental assembly 58 and administering the redundant dental assembly 74. These photos may be detailed photos showing the dental impressions in various views. Similar to the analysis and evaluation described above, a dental professional may access the photos via a corresponding web portal. The dental professional may direct the user to modify one or more aspects of administering dental impressions from the redundant dental assembly 74 based on results from the initial dental impressions as represented in the photos. For instance, the dental professional may direct the user to bite down on the dental trays, ensure that the dental trays are properly aligned both with the user's teeth and with the user's dental arch, etc. Accordingly, such embodiments may increase the likelihood of acceptance of the redundant dental impressions administered by the user based on evaluation of the initial dental impressions from the initial dental assembly 56.

[0096] Referring to FIG. 11, a dental impression kit 300 is shown having dental assemblies (discussed in more detail below) therein. The dental impression kit 300 may be ordered by a customer and shipped in a container or box 302, shown in FIG. 11, from a vendor. After administering the dental impression kit 300 at home, the customer may ship the dental impression kit 300 in the box 302 back to the vendor for analysis. The box 302 is sized for standard shipping and is likewise sized for delivery into the customer's mailbox. Accordingly, additional fees for shipment of the dental impression kit 300 in the box 302 may not be required.

[0097] Referring to FIG. 12, when the box 302 is opened, an instruction manual 304 is positioned at a top of the box contents. The instruction manual 304 provides step-by-step instructions for administering the contents of the dental impression kit 300. Referring to FIG. 13, when the instruction manual 304 is removed from the box 302, an insert 306 is exposed that includes the contents of an upper initial dental assembly 308. The initial upper dental assembly 308 includes an initial upper dental tray 310, a container of an initial upper base putty 312, and a container of an initial upper catalyst putty 314. The instruction manual 304 includes initial instructions for administering the initial upper dental assembly 308. Generally, in use, the initial upper base putty 312 is mixed with the initial upper catalyst putty 314 to form a putty mixture. The putty mixture is then positioned in the initial upper dental tray 310 to form a dental impression of the upper teeth.

[0098] Referring to FIG. 14, when the insert 306 is removed, another insert 316 is exposed that includes the contents of an initial lower dental assembly 318. The initial lower dental assembly 318 includes an initial lower dental tray 320, a container of an initial lower base putty 322, and a container of an initial lower catalyst putty 324. The instruction manual 304 includes initial instructions for administering the initial lower dental assembly 318. Generally, in use, the initial lower base putty 322 is mixed with the initial lower catalyst putty 324 to form a putty mixture. The putty mixture is then positioned in the initial lower dental tray 320 to form a dental impression of the lower teeth.

[0099] Referring to FIG. 15, when the insert 316 is removed from the box 302, an insert 326 is exposed that

includes the contents of a redundant upper dental assembly 328. The redundant upper dental assembly 328 includes a redundant upper dental tray 330, a container of a redundant upper base putty 332, and a container of a redundant upper catalyst putty 334. The instruction manual 304 includes redundant instructions for administering the redundant upper dental assembly 328. Generally, in use, the redundant upper base putty 332 is mixed with the redundant upper catalyst putty 334 to form a putty mixture. The putty mixture is then positioned in the redundant upper dental tray 330 to form a dental impression of the upper teeth.

[1010] Referring to FIG. 16, when the insert 326 is removed, another insert 336 is exposed that includes the contents of a redundant lower dental assembly 338. The redundant lower dental assembly 338 includes a redundant lower dental tray 340, a container of a redundant lower base putty 342, and a container of a redundant lower catalyst putty 344. The instruction manual 304 includes redundant instructions for administering the redundant lower dental assembly 338. Generally, in use, the redundant lower base putty 342 is mixed with the redundant lower catalyst putty 344 to form a putty mixture. The putty mixture is then positioned in the redundant lower dental tray 340 to form a dental impression of the lower teeth.

[1011] Referring to FIG. 17, another insert 350 includes a pair of gloves 76 and a dental appliance 78. The insert 350 is positioned below the insert 336. When opening the dental impression kit 10, the user may first remove the instruction manual 54 and the inserts 306, 316, 326, and 336 to gain access to the pair of gloves 76 and the dental appliance 78. The inserts 306, 316, 326, and 336 may then be positioned back into the box so that the user may appropriately follow the instructions in the instruction manual 54, as described in more detail below.

[1012] Referring to FIG. 18, an alignment kit 400 is mailed to the user after the user specific aligners have been created by the vendor. The alignment kit 400 includes a container 402 having a top insert 404. The top insert 404 includes an instruction manual 406 that provides instructions for administering the alignment kit 400. The top insert 404 also includes a case 408 for retaining aligners (described below), a case of tooth whitening 410 to be used with the aligners, and lip balm 412. A tool kit 414 is also provided in the top insert 404.

[1013] Referring to FIG. 19, the tool kit 414 includes an extractor 416 for removing aligners from the user's mouth. The extractor 416 includes a first hook 418 for pulling upper aligners off of the user's upper teeth. A second hook 420 pushes lower aligners off the user's lower teeth. The tool kit 414 also includes a file 422 for smoothing out edges of the aligners for the user's comfort. At least one rubber pellet 424 is also provided for aiding the insertion of the aligners. When the user positions the aligner's in his/her mouth, the user may chew on the rubber pellets 424 to push the aligners into position on the user's upper and lower teeth.

[1014] Referring to FIG. 20, when the top insert 404 is removed from the container 402, at least two lower inserts 426 are exposed. The lower inserts 426 include the aligners 428 that will be inserted in the user's mouth. Referring to FIG. 21, the additional lower inserts 426 may be positioned below the first layer of lower inserts 426.

[1015] Referring now to FIG. 22, in an illustrative embodiment, a system 1100 for remote orthodontic assessment and treatment includes an application server 1102 in

communication over a network 1112 with multiple other computing devices, such as one or more staff devices 1104, user devices 1106, provider devices 1108, and/or dental labs 1110. In use, as described further below, the application server 1102 allows a user (using a user device 1106) to order a dental impression kit 10, as described above, and then upload images of the user's mouth and teeth to the application server 1102. The application server 1102 allows a staff professional/hygienist to review and approve the images using the staff device 1104, and then allows a provider (e.g., an orthodontist) to perform a photo assessment using the provider device 1108. After the photo assessment is approved, the application server 1102 receives a 3D treatment plan from the dental lab 1110, and the application server 1102 allows the provider to approve the treatment plan using the provider device 1108. After approval, the application server 1102 allows the user to view the 3D treatment plan using the user device 1106. The application server 1102 optimizes the 3D treatment plan for viewing on the user device 1106. Thus, the system 1100 may allow for remote orthodontic treatment and assessment, without requiring the user to visit the provider's physical offices. Accordingly, the system 1100 may improve the cost and/or availability of orthodontic services. Additionally, by optimizing the 3D treatment plan, the system 1100 provides an improved user experience for viewing treatment plans without the aid of an orthodontist.

[1016] The application server 1102 may be embodied as any type of computation or computer device capable of performing the functions described herein, including, without limitation, a computer, a server, a workstation, a desktop computer, a laptop computer, a notebook computer, a tablet computer, a mobile computing device, a wearable computing device, a network appliance, a web appliance, a distributed computing system, a processor-based system, and/or a consumer electronic device. As such, the application server 1102 may be embodied as a single server computing device or a collection of servers and associated devices. For example, in some embodiments, the application server 1102 may be embodied as a "virtual server" formed from multiple computing devices distributed across the network 1112 and operating in a public or private cloud. Accordingly, although the application server 1102 is illustrated in FIG. 1 and described below as embodied as a single server computing device, it should be appreciated that the application server 1102 may be embodied as multiple devices cooperating together to facilitate the functionality described below. As shown in FIG. 1, the application server 1102 illustratively include a processor 1120, an input/output subsystem 1122, a memory 1124, a data storage device 1126, and a communication subsystem 1128, and/or other components and devices commonly found in a server computer or similar computing device. Of course, the application server 1102 may include other or additional components, such as those commonly found in a server computer (e.g., various input/output devices), in other embodiments. Additionally, in some embodiments, one or more of the illustrative components may be incorporated in, or otherwise form a portion of, another component. For example, the memory 1124, or portions thereof, may be incorporated in the processor 1120 in some embodiments.

[1017] The processor 1120 may be embodied as any type of processor capable of performing the functions described herein. The processor 1120 may be embodied as a single or

multi-core processor(s), digital signal processor, microcontroller, or other processor or processing/controlling circuit. Similarly, the memory 1124 may be embodied as any type of volatile or non-volatile memory or data storage capable of performing the functions described herein. In operation, the memory 1124 may store various data and software used during operation of the application server 1102, such as operating systems, applications, programs, libraries, and drivers. The memory 1124 is communicatively coupled to the processor 1120 via the I/O subsystem 1122, which may be embodied as circuitry and/or components to facilitate input/output operations with the processor 1120, the memory 1124, and other components of the application server 1102. For example, the I/O subsystem 1122 may be embodied as, or otherwise include, memory controller hubs, input/output control hubs, platform controller hubs, integrated control circuitry, firmware devices, communication links (i.e., point-to-point links, bus links, wires, cables, light guides, printed circuit board traces, etc.) and/or other components and subsystems to facilitate the input/output operations. In some embodiments, the I/O subsystem 1122 may form a portion of a system-on-a-chip (SoC) and be incorporated, along with the processor 1120, the memory 1124, and other components of the application server 1102, on a single integrated circuit chip.

[0108] The data storage device 1126 may be embodied as any type of device or devices configured for short-term or long-term storage of data such as, for example, memory devices and circuits, memory cards, hard disk drives, solid-state drives, or other data storage devices. The communication subsystem 1128 of the application server 1102 may be embodied as any communication circuit, device, or collection thereof, capable of enabling communications between the application server 1102 and other remote devices over a network. The communication subsystem 1128 may be configured to use any one or more communication technology (e.g., wired or wireless communications) and associated protocols (e.g., Ethernet, InfiniBand®, Bluetooth®, WiMAX, etc.) to effect such communication.

[0109] As shown, the application server 1102 may also include one or more peripheral devices 1130. The peripheral devices 1130 may include any number of additional input/output devices, interface devices, and/or other peripheral devices. For example, in some embodiments, the peripheral devices 1130 may include a display, touch screen, graphics circuitry, keyboard, mouse, speaker system, microphone, network interface, and/or other input/output devices, interface devices, and/or peripheral devices.

[0110] As described further below, the staff device 1104 is configured to upload, review, and otherwise manage data stored by the application server 1102. The staff device 1104 may be embodied as any type of device capable of performing the functions described herein, such as, without limitation, a smartphone, a cellular phone, a tablet computer, a notebook computer, a laptop computer, a desktop computer, a consumer electronic device, a wearable computing device, a smart appliance, and/or any other computing device capable of performing the functions described herein. Accordingly, the staff device 1104 may include a processor, an I/O subsystem, a memory, a data storage device, communication circuitry, and/or other components and devices commonly found in a notebook computer or similar computing device. The individual components of the staff device 1104 may be similar to the corresponding components of the

application server 1102, the description of which is applicable to the corresponding components of the staff device 1104 and is not repeated herein so as not to obscure the present disclosure.

[0111] As described further below, the user device 1106 is configured to allow a user to send and receive images, questionnaire responses, and other data with the application server 1102. The user device 1106 may be embodied as any type of device capable of performing the functions described herein, such as, without limitation, a smartphone, a cellular phone, a tablet computer, a notebook computer, a laptop computer, a desktop computer, a consumer electronic device, a wearable computing device, a smart appliance, and/or any other computing device capable of performing the functions described herein. Accordingly, the user device 1106 may include a processor, an I/O subsystem, a memory, a data storage device, communication circuitry, and/or other components and devices commonly found in a smartphone or similar computing device. The individual components of the user device 1106 may be similar to the corresponding components of the application server 1102, the description of which is applicable to the corresponding components of the user device 1106 and is not repeated herein so as not to obscure the present disclosure.

[0112] As described further below, the provider device 1108 is configured to allow a provider to review image assessments and treatment plans and to otherwise access the application server 1102. The provider device 1108 may be embodied as any type of device capable of performing the functions described herein, such as, without limitation, a smartphone, a cellular phone, a tablet computer, a notebook computer, a laptop computer, a desktop computer, a consumer electronic device, a wearable computing device, a smart appliance, and/or any other computing device capable of performing the functions described herein. Accordingly, the provider device 1108 may include a processor, an I/O subsystem, a memory, a data storage device, communication circuitry, and/or other components and devices commonly found in a notebook computer or similar computing device. The individual components of the provider device 1108 may be similar to the corresponding components of the application server 1102, the description of which is applicable to the corresponding components of the provider device 1108 and is not repeated herein so as not to obscure the present disclosure.

[0113] The dental lab 1110 may be embodied as any dental analysis and/or manufacturing facility that is capable of generating orthodontic treatment plans or otherwise performing the functions described herein. In particular, the dental lab 1110 may include or otherwise have access to one or more computing devices capable of executing software to generate orthodontic treatment plans.

[0114] As discussed in more detail below, the application server 1102, the staff device 1104, the user device 1106, and the provider device 1108 may be configured to transmit and receive data with each other and/or other devices of the system 1100 over the network 1112. The network 1112 may be embodied as any number of various wired and/or wireless networks. For example, the network 1112 may be embodied as, or otherwise include, a wired or wireless local area network (LAN), and/or a wired or wireless wide area network (WAN). As such, the network 1112 may include any number of additional devices, such as additional computers, routers, and switches, to facilitate communications among

the devices of the system 1100. In the illustrative embodiment, the network 1112 is embodied as a local Ethernet network.

[0115] Referring now to FIG. 23, in an illustrative embodiment, the application server 1102 establishes an environment 1200 during operation. The illustrative environment 1200 includes a staff portal 1202, a provider portal 1204, a user portal 1206, an optimizer 1208, and a data repository 1210. The various components of the environment 1200 may be embodied as hardware, firmware, software, or a combination thereof. As such, in some embodiments, one or more of the components of the environment 1200 may be embodied as circuitry or collection of electrical devices (e.g., staff portal circuitry 1202, provider portal circuitry 1204, user portal circuitry 1206, optimizer circuitry 1208, and/or data repository circuitry 1210). It should be appreciated that, in such embodiments, one or more of the staff portal circuitry 1202, the provider portal circuitry 1204, the user portal circuitry 1206, the optimizer circuitry 1208, and/or the data repository circuitry 1210 may form a portion of one or more of the processor 1120, the I/O subsystem 1122, and/or other components of the application server 1102. Additionally, in some embodiments, one or more of the illustrative components may form a portion of another component and/or one or more of the illustrative components may be independent of one another.

[0116] The data repository 1210 is configured to manage and store case data related to each user. The data repository 1210 may be configured to receive multiple images that represent the teeth of a user. The data repository 1210 may be further configured to receive a treatment plan for the user. The treatment plan may include a sequence of three-dimensional models indicative of the teeth of the user. Thus, the data repository 1210 may store, among other data, image data 1212 and/or treatment plan data 1214.

[0117] The staff portal 1202 is configured to manage data access and other communications with the staff devices 1104. In particular, the staff portal 1202 may be configured to provide the images that represent the teeth of the user to a staff device 1104. The staff portal 1202 is further configured to receive an approval from the staff device 1104 indicating that a person (e.g., a staff professional person and/or hygienist) has approved the images for assessment by a provider (e.g., an orthodontist).

[0118] The provider portal 1204 is configured to manage data access and other communications with the provider devices 1108. In particular, the provider portal 1204 may be configured to provide the images to a provider device 1108 in response receiving the approval from the staff device 1104. The provider portal 1204 may be further configured to receive an approval from the provider device 1108 indicating that the provider successfully performed an assessment of the fitness of the user for treatment. A treatment plan may be received in response to that approval, and the provider portal 1204 may be further configured to provide the treatment plan to the provider device 1108 and to receive an approval from the provider device 1108 indicating that the provider approved the treatment plan.

[0119] In some embodiments, the user may be provided history and consent forms. The history and consent forms may be forms which a user provides various information for use in generation of the user's aligners and/or for determination in the fitness for treatment. For instance, the user may be provided with a series of questions that illicit information

related to various health and dental information, such as previous dental treatments, health conditions, etc. Additionally, the user may be provided a consent form where the user consents to treatment. In some embodiments, the history and consent forms may be provided to the user upon ordering the impression kit 10. The history and consent forms may be provided electronically. In some embodiments, the history and consent forms may be provided a duration after the user orders the kit 10. For instance, the history and consent forms may be provided a day after the user orders the kit 10. In these embodiments, the user may be less intimidated by the history and consent forms by providing them at a later date rather than the date of the order.

[0120] The user portal 1206 is configured to manage data access and other communications with the user devices 1106. In particular, the user portal 1206 may be configured to receive the images indicative of the teeth of the user from a user device 1106. For instance, the user may be required to provide images when the user orders a dental impression kit 10 (as opposed to an oral scan center). For instance the user may be required to provide a number of images (e.g., three images, five images, seven images, etc.). In some embodiments, the images may include an upper, open view image, a lower, open view image, and a straight-on, closed view image. The user portal 1206 may be further configured to receive a dental history questionnaire response from the user device 1106. The dental history questionnaire response may be included with the images to the staff device 1104 and/or to the provider device 1108. The user portal 1206 is further configured to provide a visualization of the treatment plan to the user device 1106 in response to receiving approval of the treatment plan from the provider device 1108.

[0121] The optimizer 1208 is configured to optimize the sequence of three-dimensional models to generate an optimized sequence of three-dimensional models. The visualization of the treatment plan may use the optimized sequence of three-dimensional models. The optimizer 1208 may increase the speed, rendering, and/or quality of the visualization of the treatment plan.

[0122] Referring now to FIGS. 23A and 23B, in use, the application server 1102 may execute a method 1300 for remote orthodontic treatment and assessment. It should be appreciated that, in some embodiments, the operations of the method 1300 may be performed by one or more components of the environment 1200 of the application server 1102 as shown in FIG. 23. The method 1300 begins in block 1302, in which the application server 1102 receives a smile assessment response from a user device 1106. The smile assessment response may be embodied as a web form, electronic message, or other data submitted by the user device 1106 that is indicative of whether the user is a potential candidate for orthodontic treatment. For example, the smile assessment response may include answers to questions indicating the current condition of the user's mouth and the user's chief complaint (i.e., the user's biggest concern with his or her smile). The smile assessment response may be submitted in response to a web form or other web page that includes appropriate questions and instructions. One potential embodiment of a smile assessment web page is described below in connection with FIG. 26. After receiving the smile assessment response, in block 1304 the application server 1102 determines whether the user is a potential candidate for orthodontic treatment based on the smile assessment

response. If the application server **1102** determines that the user is not a good candidate, the method **1300** loops back to block **1302**, in which the application server **1102** may receive additional smile assessment responses from the same user device **1106** and/or other user devices **1106**. If the application server **1102** determines that the user is a good candidate, the method **1300** advances to block **1306**.

[0123] In block **1306**, the application server **1102** determines an appropriate intake technique for the user. In the illustrative embodiment, potential intake techniques include performing a three-dimensional (3D) scan of the user's teeth and mouth at an oral scan center, or delivering a dental impression kit **10**, as described above. The application server **1102** may allow the user to select an intake technique using the user device **1106**, for example by selecting an option from a web page. In some embodiments, the application server **1102** may determine whether the user is located near an oral scan center and, if near a scan center, present the user with the scan option. If the application server **1102** determines to use the dental impression kit **10**, the method **1300** branches to block **1312**, described below. If the application server **1102** determines to use the 3D scan, the method **1300** branches to block **1308**.

[0124] In block **1308**, the application server **1102** allows the user to schedule an appointment at a 3D oral scan center. The application server **1102** may use any technique to schedule the appointment. For example, the application server **1102** may provide a web application or other interface to the user device **1106** to allow the user to select a date and time for the appointment. In some embodiments, the user may select a date and time for the appointment when the user had impressions rejected (or the user did not return their dental impressions). The application server **1102** may store the appointment information and provide reminders to the user as appropriate. At the appointment, a professional uses a 3D scanner to capture a 3D optical scan of the user's mouth. The professional may be a hygienist or other trained professional, but is typically not an orthodontist. After the 3D scan appointment, in block **1310** the application server **1102** receives 3D optical scan data for the user's mouth. The 3D optical scan data may be embodied as any data file or collection of data files that include images of the patient's mouth as well as corresponding depth or other spatial information. After receiving the 3D optical scan data, the method **1300** advances to block **1322**, described below.

[0125] Referring back to block **1306**, if the application server **1102** determines to use the dental impression kit **10**, the method **1300** branches to block **1312**, in which the application server **1102** schedules delivery of a dental impression kit **10** to the user. In some embodiments, the user may order or otherwise receive the kit if the user does not show up to (or cancels) their appointment at the 3D oral scan center (e.g., referred to above at block **1308**). After the user has received the dental impression kit **10**, in block **1314** the application server **1102** receives images of the user's mouth and teeth. The user device **1106** may upload the images to the application server **1102**, for example, through a web interface. In some embodiments, the application server **1102** may establish an account for the user. The application server **1102** may present the user with an account status user interface that provides access to an interface for uploading images. Images may be updated at any time after the account is created, for example after purchasing the dental impression kit **10**, during use of the dental impression kit **10**, and/or

after creating a scan appointment. One potential embodiment of an account status user interface is described below in connection with FIG. **27**. As part of the image upload web interface, the application server **1102** may provide instructions to the user on which views to capture and upload, and in some embodiments may provide tips to improve image quality. For example, the instructions may recommend that the user has another person assist in taking the images and/or may recommend using a flash or a bright light source such as a bathroom light or a window on a sunny day. As described above, the dental impression kit **10** may also include an instruction manual **54** that includes similar instructions and/or tips. In block **1316**, the application server **1102** receives images for three views of the user's mouth: a view of the upper teeth with the mouth open, a view of the lower teeth with the mouth open, and a view of the teeth from straight on with the mouth closed. One potential embodiment of a web interface to provide instructions to the user and to upload images is described further below in connection with FIGS. **27A-27C**. In some embodiments, in block **1318** the user may use the dental appliance **78** to separate the user's lips and open the user's mouth while taking the images, as described above. In some embodiments, in block **1320** the application server **1102** may receive additional images of the user's mouth and teeth, such as an upper, closed view; a left side, closed view; a right side, closed view; and/or a straight-on, full-smile view. As described further below, the additional images may be requested by a staff professional, a hygienist, and/or a provider while performing an image assessment. For example, the additional images may be requested for complicated cases. After receiving the images, the method **1300** advances to block **1322**.

[0126] In block **1322**, the application server **1102** receives a dental history questionnaire response from the user device **1106**. The dental history questionnaire response may be embodied as any web form, electronic message, or other data submitted by the user device **1106**. The dental history questionnaire response may include information related to the user's dental history that may be used by a staff professional, hygienist, and/or provider to determine the user's fitness for treatment. One potential embodiment of a dental history questionnaire is described below in connection with FIGS. **28A-28E**.

[0127] In block **1324**, the application server **1102** provides images of the user's mouth and teeth as well as the dental history questionnaire response to a staff professional and/or hygienist for review and approval. For example, the application server **1102** may establish a staff portal web site that is accessible by the staff device **1104**. Because the images of the user's mouth and teeth and the dental history questionnaire response may include personal health information, the application server **1102** may restrict access to the staff portal or other user interfaces to authorized users (e.g., authorized staff professionals and/or hygienists). The staff professional/hygienist may review the images and questionnaire data to determine whether the images are sufficient to allow the provider to determine the user's fitness for treatment. For example, the staff professional/hygienist may determine whether each of the images are of the correct view and/or are of sufficient quality. The staff professional/hygienist may indicate whether each image is approved and may also request that the user provide additional views or other images. One potential embodiment of a web interface pro-

vided by the application server **1102** to perform the image review is described below in connection with FIGS. **29A** and **29B**. In block **1326**, the application server **1102** determines whether the staff professional/hygienist approved the images. If not, the method **1300** may loop back to block **1314**, in which the application server **1102** receives additional images from the user device **1106**. If the staff professional/hygienist approved the images, the method **1300** advances to block **1328**.

[0128] In block **1328**, the application server **1102** provides images of the user's mouth and teeth as well as the dental history questionnaire response to a provider for assessment and approval. For example, the application server **1102** may establish a provider portal web site that is accessible by the provider device **1108**. Because the images of the user's mouth and teeth and the dental history questionnaire response may include personal health information, the application server **1102** may restrict access to the provider portal or other user interfaces to authorized users (e.g., authorized providers). The provider may review the images and questionnaire data to determine the user's fitness for treatment. For example, the provider may determine whether the user's mouth and/or desired treatment outcome are fit for treatment with invisible plastic aligners. Continuing that example, the user may not be fit for treatment, for example, if the user's mouth and/or desired treatment outcome requires pulling teeth, interproximal reduction, or performing other procedures that cannot be achieved with aligners. To perform the assessment, the provider may access a provider portal with a web interface similar to the web interface shown in FIGS. **29A** and **29B**. Features of the provider portal are also described below in connection with FIGS. **30A-30E**. In block **1330**, the application server **1102** determines whether the provider approved the images. If not, the method **1300** may loop back to block **1314**, in which the application server **1102** receives additional images from the user device **1106**. If the provider approved the images, the method **1300** advances to block **1332**, shown in FIG. **24B**.

[0129] Referring now to FIG. **24B**, in block **1332** the application server **1102** provides 3D image data for the user's mouth to the dental lab **1110**. The application server **1102** may use any technique to provide the data, for example by transferring data over the network **1112** to a server or other computing device of the dental lab **1110**. The 3D image data may be generated using any appropriate technique. In some embodiments, in block **1334** the application server **1102** provides data generated during a 3D optical scan, which was received by the application server **1102** as described above in connection with block **1310**. In some embodiments, in block **1336** the application server **1102** provides data generated based on impressions created using the dental impression kit **10**, which was scheduled for delivery as described above in connection with block **1312**. In some embodiments, the dental impressions themselves may be provided to the dental lab **1110**, and the dental lab **1110** may generate the 3D image data based on the impressions (and/or on the images provided by the user). After receiving the 3D image data, the dental lab **1110** may use typical dental software to generate a treatment plan.

[0130] After the dental lab **1110** creates the treatment plan, in block **1338** the application server **1102** receives the treatment plan generated by the dental lab **1110**. The treatment plan may be embodied as any data indicative of a series of steps used to correct or otherwise modify the positions of

the user's teeth. In particular, the treatment plan may represent the user's teeth and how they move through the duration of the treatment plan. The treatment plan may be directed to the user's upper teeth, lower teeth, or both upper and lower teeth. In block **1340**, the application server **1102** receives a 3D model of the user's mouth and teeth for each step of the treatment plan. Thus, the treatment plan may indicate the position of the user's teeth as they are modified over the course of treatment. The 3D models of the treatment plan may be embodied as STL files, OBJ files, or any other data file that is indicative of a three-dimensional object and/or scene.

[0131] In block **1342**, the application server **1102** optimizes the treatment plan 3D models to render on the user device **1106**. The application server **1102** may perform optimization to reduce the size of corresponding data files or to otherwise improve rendering performance on the user device **1106**. One potential embodiment of a method for optimizing the treatment plan 3D models is described below in connection with FIG. **25**.

[0132] After optimizing the treatment plan 3D models, in block **1344** the application server **1102** provides the treatment plan to the provider for approval. For example, the application server **1102** may establish a provider portal web site that is accessible by the provider device **1108**. Because the treatment plan may include personal health information, the application server **1102** may restrict access to the provider portal or other user interfaces to authorized users (e.g., authorized providers). Using the provider portal, the provider may review 3D images of the steps of the treatment plan, and may approve the plan, reject the plan, request modifications to the plan, or otherwise review the treatment plan. One potential embodiment of a user interface for the provider portal is described below in connection with FIGS. **30A-30E**. In block **1346**, the application server **1102** determines whether the provider has approved the treatment plan. If not, the method **1300** loops back to block **1332**, in which the dental lab **1110** may modify the treatment plan or otherwise generate a new treatment plan. If the treatment plan is approved, the method **1300** advances to block **1348**.

[0133] In block **1348**, the application server **1102** provides a visualization of the treatment plan to the user. For example, the application server **1102** may establish a user portal web site that is accessible by the user device **1106**. Because the treatment plan may include personal health information, the application server **1102** may restrict access to the user portal or other user interfaces to the authorized user. The visualization may allow the user to view the 3D models of the user's mouth and teeth for each step of the treatment process from multiple angles. As described above in connection with block **1342**, the 3D models of the treatment plan are optimized for rendering by the user device **1106**, which provides the user with a responsive user interface. As described above, the application server **1102** may establish an account for the user, and an account status user interface may provide access to the treatment plan visualization user interface. One potential embodiment of an account status user interface is described below in connection with FIG. **32**. One potential embodiment of a treatment plan visualization user interface is described below in connection with FIG. **33**.

[0134] In block **1350**, the application server **1102** determines whether the user has purchased the approved treatment plan. The user may purchase the treatment plan, for example, through an account user interface provided by the

application server **1102** to the user device **1106**. If the user has not purchased the approved treatment plan, the method **1300** loops back to block **1348**, in which the application server **1102** may continue to provide the visualization of the treatment plan to the user. If the treatment plan is purchased, the method **1300** advances to block **1352**.

[0135] In block **1352**, one or more aligners are manufactured for the treatment plan and distributed to the user. Any appropriate technique may be used to manufacture and distribute the aligners. For example, the aligners may be manufactured by 3D printing physical models of the user's teeth and then molding plastic aligners using the physical models of the user's teeth. Multiple aligners may be distributed to the user each month. For example, the user may be sent three aligners each month, with the first aligner to be worn for one week, the second aligner to be worn for one week, and the third aligner to be worn for two weeks. During the manufacturing and distribution process, the application server **1102** may coordinate access to order information, the treatment, plan, and other data associated with the user. In block **1354**, it is determined whether the treatment plan is complete. For example, a treatment plan may have a duration of five months. If the plan is not complete, the method **1300** loops back to block **1352** to continue manufacturing and distributing aligners. If the plan is complete, the method **1300** may advance to block **1356**, in which one or more retainers may be manufactured and distributed to the user. In some embodiments, the application server **1102** may perform a check-in process after a predetermined amount of time has elapsed during treatment, for example a 90-day check in process. As part of the check-in process, the patient may answer a questionnaire and submit photos that are reviewed by a dental professional. Thus, the application server **1102** may monitor the progress of the patient during treatment. One potential embodiment of a user interface for the check-in progress is shown in FIGS. 37A-37D. The method **1300** may loop back to block **1356** to continue manufacturing and distributing retainers, or in some embodiments may be completed. It should be understood that the method **1300** illustrates techniques for remote orthodontic treatment and assessment for a single user; it should be understood that the application server **1102** may execute multiple instances of the method **1300** for multiple users.

[0136] Referring now to FIG. 25, in use, the application server **1102** may execute a method **1400** for 3D model optimization. The method **1400** may be executed, for example, in connection with block **1342** of the method **1300**, described above in connection with FIG. 24B. It should be appreciated that, in some embodiments, the operations of the method **1400** may be performed by one or more components of the environment **1200** of the application server **1102** as shown in FIG. 23. The method **1400** begins in block **1402**, in which the application server **1102** optimizes the 3-D models of a treatment plan.

[0137] Referring now to FIG. 26, a user interface **1500** for a smile assessment is shown. The user interface **1500** may be used to receive a smile assessment response as described above in connection with block **1302** of FIG. 24A. The illustrative user interface **1500** is a web page provided by the application server **1102** to the user device **1106**; however, it should be understood that the user interface **1500** may be embodied as native application, managed application, or other interface of the user device **1106**. As shown, the user

interface **1500** includes multiple input elements **1502** that allow the user to provide information regarding current condition of the user's mouth and the user's chief complaint. The user interface **1500** includes a submit button **1504** that, when selected by the user, provides the smile assessment response to the application server **1102**. In some embodiments, the user interface **1500** may include additional input elements **1506** (not shown) to collect additional information, such as user contact information (e.g., email address or phone number, mailing address, zip code), account information, or other information.

[0138] Referring now to FIG. 27, a user interface **1600** for account status is shown. The illustrative user interface **1600** is a web page provided by the application server **1102** to the user device **1106**; however, it should be understood that the user interface **1600** may be embodied as native application, managed application, or other interface of the user device **1106**. The user interface **1600** may be used to display the status of the user's account, including indicating additional information required from the user or otherwise indicating the next step to be performed by the user. For example, the illustrative user interface **1600** indicates that the user still needs to upload photos. The user interface **1600** includes a button **1602** that, when selected by the user, launches a user interface for uploading the photos. It should be understood that the user interface **1600** may include information and/or actions for other steps, such as scheduling a 3D scan appointment, reminding the user of a 3D scan appointment, indicating that images were received and are being reviewed, indicating that a treatment plan is being created, or other status information.

[0139] Referring now to FIGS. 27A-27C, a user interface **1700** for uploading images of the user's mouth and teeth is shown. The user interface **1700** may be used to receive images from the user device **1106** as described above in connection with block **1314** of FIG. 24A. The illustrative user interface **1700** is a web page provided by the application server **1102** to the user device **1106**; however, it should be understood that the user interface **1700** may be embodied as native application, managed application, or other interface of the user device **1106**. As shown, the user interface **1700** includes instructions **1702**, **1706**, **1710** and corresponding submit buttons **1704**, **1708**, **1712** for the three images that are used for photo assessment. In particular, the instructions **1702** and submit button **1704** shown in FIG. 28A are for an upper, open view; the instructions **1706** and submit button **1708** shown in FIG. 28B are for a lower, open view; and the instructions **1710** and submit button **1712** shown in FIG. 28C are for a straight-on, closed view. The user interface **1700** further includes a button **1714** to cause the user device **1106** to move on to the dental history questionnaire.

[0140] Referring now to FIGS. 28A-28C, a user interface **1800** for a dental history questionnaire is shown. The user interface **1800** may be used to receive a dental history questionnaire response as described above in connection with block **1322** of FIG. 24A. The illustrative user interface **1800** is a web page provided by the application server **1102** to the user device **1106**; however, it should be understood that the user interface **1800** may be embodied as native application, managed application, or other interface of the user device **1106**. As shown, the user interface **1800** includes multiple input elements **1802** that allow the user to provide information regarding the user's dental history. The user

interface **1800** also includes a submit button **1804** that, when selected by the user, provides the dental history questionnaire response to the application server **1102**. Referring now to FIGS. **28D-28E**, another potential embodiment of a user interface **1800** for a dental history questionnaire is shown.

[0141] Referring now to FIGS. **29A** and **29B**, a user interface **1900** for photo assessment review is shown. The user interface **1900** may be used to provide data to the staff professional/hygienist and to receive approval as described above in connection with blocks **1322**, **1324** of FIG. **24A**. The illustrative user interface **1900** is a web page provided by the application server **1102** to the staff device **1104**; however, it should be understood that the user interface **1900** may be embodied as native application, managed application, or other interface of the staff device **1104** and/or application server **1102**. Additionally or alternatively, in some embodiments the user interface **1900** may be embodied as an embedded view within a staff portal user interface provided by the application server **1102**.

[0142] As shown in FIG. **30A**, the user interface **1900** includes multiple indicator elements **1902** for the different views. Each indicator element **1902** may indicate whether the image for the associated view has been approved, rejected, or is pending review. As shown, the user interface **1900** includes indicator elements **1902** for seven potential views, including the three views described above in connection with FIGS. **27A-27C**, as well as four additional views that may be requested for complex cases. The user interface **1900** further includes an image thumbnail **1904** for the selected view (which is illustratively a line drawing but could include a photographic image) and a popup list **1906** used to approve or reject the selected image. The user interface **1900** includes a submit button **1908** that, when selected by the staff professional/hygienist, provides the approval to the application server **1102**. The user interface **1900** also includes a view **1910**, shown in FIG. **30B**, that displays the dental history questionnaire response for the user. The staff professional/hygienist may review data displayed in the view **1910** when performing the photo review.

[0143] Referring now to FIGS. **31A-31E**, a user interface **2000** for a provider portal is shown. The user interface **2000** may be used to allow a provider to perform a photo assessment, review a treatment plan, or otherwise interact with a user's case. The illustrative user interface **2000** is a web page provided by the application server **1102** to the provider device **1108**; however, it should be understood that the user interface **2000** may be embodied as native application, managed application, or other interface of the provider device **1108**. As shown in FIG. **31A**, the user interface **2000** may include a case listing view **2002**. The case listing view **2002** may include a case summary view **2004** for each user assigned to or otherwise associated with the provider. Selecting a case summary view **2004** may cause the provider device **1108** to display a corresponding case detail view **2006**, shown in FIGS. **30B-30E**.

[0144] The case detail view **2006** may include a tabbed interface with multiple sub-views, including a patient treatment plan view **2008**, shown in FIG. **31B**. The patient treatment plan view **2008** may provide information on the treatment plan, the user's chief complaint, and the photo assessment, and may also allow the provider to initiate evaluation of the treatment plan and the photo assessment. The case detail view **2006** also includes an action box **2010**, which includes buttons to allow the provider to approve or

reject the treatment plan. As shown in FIG. **31C**, the case detail view **2006** may include a form and record view **2012**, which may display images (including treatment plan images and/or photo assessment images) and other documents for the provider to review. As shown in FIG. **31D**, the case detail view **2006** may include a case inbox view **2014** that displays communications relevant to the user's case that are managed by the application server **1102**. As shown in FIG. **31E**, the case detail view **2006** may include a lab view **2016** that displays information for the dental lab **1110** assigned to the case.

[0145] Referring now to FIG. **32**, a user interface **2100** for account status is shown. The illustrative user interface **2100** is a web page provided by the application server **1102** to the user device **1106**; however, it should be understood that the user interface **2100** may be embodied as native application, managed application, or other interface of the user device **1106**. The user interface **2100** may be used to display the status of the user's account, including indicating additional information required from the user or otherwise indicating the next step to be performed by the user. For example, the illustrative user interface **2100** indicates that the user's treatment plan is completed and ready for viewing. The user interface **2100** includes a button **2102** that, when selected by the user, launches a user interface for viewing the treatment plan. The user interface **2100** also includes a button **2104** that, when selected by the user, launches a user interface to purchase aligners for the treatment plan. The user interface for purchasing the aligners may collect account information, payment information, and perform other e-commerce functions as described above.

[0146] Referring now to FIG. **33**, a user interface **2200** for viewing a 3D treatment plan is shown. The user interface **2200** may be used to view the treatment plan as described above in connection with block **1348** of FIG. **24B**. The illustrative user interface **2200** is a web page provided by the application server **1102** to the user device **1106**; however, it should be understood that the user interface **2200** may be embodied as native application, managed application, or other interface of the user device **1106**. As shown, the user interface **2200** includes a 3D model view **2202** that displays the 3D model of the treatment plan. As described above in connection with block **1342** of FIG. **24B**, the 3D model may be optimized for efficient viewing on the user device **1106**. The user interface **2200** also includes a button bar **2204** that allows the user to switch between particular views of the 3D model and a slider **2206** that allows the user to switch between particular phases of the treatment plan. For example, the illustrative user interface **2200** displays a five-month treatment plan, and the slider **2206** allows the user to display a 3D model for each month of the treatment plan.

[0147] Referring now to FIGS. **33A-33F**, a user interface **2300** for a staff portal is shown. The user interface **2300** may be used to store and manage all data relating to a particular user's case. Thus, the user interface **2300** may be used as an interface to a secure electronic medical records repository provided by the application server **1102**. The illustrative user interface **2300** is a web page provided by the application server **1102** to the staff device **1104**; however, it should be understood that the user interface **2300** may be embodied as native application, managed application, or other interface of the staff device **1104** and/or the application server **1102**. The illustrative user interface **2300** shown in FIGS. **33A-**

33F illustrates one potential embodiment of the documents and other data that may be stored for each user by the application server 1102. As shown in FIGS. 33A-33F, the user interface 2300 includes multiple views, with each view allowing access to part of the data associated with a particular user's case. As shown in FIG. 34A, the user interface 2300 may include a case link view 2302, a prescription view 2304, a treatment plan revision view 2306, and an order view 2308. The treatment plan revision view 2306 may track changes made to the treatment plan during the provider's review process, as described above in connection with blocks 1332 to 1346 of FIG. 24B, and the prescription view 2304 may be populated after the provider has approved a treatment plan. As shown in FIG. 34B, the user interface 2300 may include a case detail view 2310, which includes details on the user's contact information, payment information, case status, and also includes links to the user's photo assessment and other information. As shown in FIG. 34C, the user interface 2300 may include a journal view 2312, which records events related to the user's case. As shown in FIG. 34D, the user interface 2300 may include a journal entry view 2314, which allows a staff professional or other person to enter events into the journal for the user's case. Each journal entry may be restricted by audience (e.g., staff, provider, user, or other audience). As shown in FIG. 34E, the user interface 2300 may include a case message view 2316, which records all messages sent via the application server 1102 concerning the user's case. The messages may be exchanged, for example, between the provider, staff, and/or the dental lab 1110 for a case. As shown in FIG. 34F, the user interface 2300 may include a case file view 2318 and a case document view 2320. The views 2318, 2320 may provide an interface to secure storage for all images, treatment plans, consent forms, and other documents related to a user's case.

[0148] Referring to FIGS. 34-36, another embodiment of a dental tray 200 includes a substantially arched mouth insert 202 that is sized and shaped to be inserted into the user's mouth. Particularly, the insert 202 is sized and shaped to be received into either an upper portion or a lower portion of the user's mouth. The insert 202 includes a cavity 204 defined by a bottom wall 206 and a pair of sidewalls 208 extending upward from the bottom wall 206. The cavity 204 is sized to receive the putty mixture. When the dental tray 200 is inserted into the user's mouth, the user bites down on the dental tray 200 so that the user's teeth are within the cavity 204 and bite into the putty mixture. A flange 210 extends from a front of the dental tray 200. The flange 210 is configured to be gripped by the user to insert and remove the dental tray 200 from the user's mouth.

[0149] Referring to FIGS. 39 and 40, a container 500 containing the contents of a dental impression kit 300 is shown according to another example embodiment. In some embodiments, the container 500 includes the same contents of the dental impression kit 300 of FIG. 11. For instance, the same container 500 may be used for shipping the contents of the dental impression kit 300, and for returning the contents of the dental impression kit 300 back to the vendor following administration of the contents by the customer as outlined above. As illustrated, the container 500 includes a first label 501, a second label 502, and a third label 503.

[0150] Specifically, FIG. 39 shows a perspective view of the container 500 including the first label 501 and the third label 503. In some embodiments, the first label 501 may be a label indicating a predetermined time frame for returning

the contents of the dental impression kit 300, as will be discussed in greater detail below. The third label 503 may be a label indicating that the return mailing label is already attached to the container 500. FIG. 40 shows a side view of the container 500 including the second label 502. The second label 502 may be a return mailing label printed or otherwise represented thereon.

[0151] In some embodiments, the container 500 may be assigned a predetermined time frame for returning the contents of the dental impression kit 300 to the vendor. The predetermined time frame may be a predetermined number of business days, a predetermined number of weeks (e.g., one week, two weeks, four weeks, etc.), a predetermined number of months (e.g., one month, two months, etc.), etc. The predetermined time frame maybe set by the vendor. The vendor may set the predetermined time frame based on the date in which the customer ordered the dental impression kit 300. For example, the customer may order the dental impression kit 300 on a Friday. The dental impression kit 300 may be shipped out the following Monday. The vendor may set the predetermined time frame from the date of the customer order (e.g., two weeks from the Friday). In other instances, the vendor may set the predetermined time frame from the date of shipment (e.g., two weeks from the Monday). In still other instances, the vendor may set the predetermined time frame from the date of receipt. Continuing the previous example, the order may be shipped overnight and received by the customer on the Tuesday following the Friday order. The vendor may set the predetermined time frame from the date of receipt by the customer (e.g., two weeks from the Tuesday). In still other instances, the vendor may provide a universal predetermined time frame (e.g., "Please return your completed impressions no later than two weeks from receipt of this kit" or "Please return your completed impressions no later than two weeks from your order date").

[0152] In some embodiments, the instruction manual 304 may further include instructions for returning the dental impression kit 300. For instance, the instruction manual 304 may include instructions to return the dental impression kit 300 within the predetermined time frame discussed above.

[0153] In each of these instances, the customer may be instructed to return the dental impression kit 300 within the predetermined time frame. As stated above, in some embodiments, the predetermined time frame may be represented on a label 501 of the box 302. In other embodiments, the predetermined time frame may be represented in the instruction manual 304 or provided on a separate label included inside of the box 302. In instructing the customer to return the dental impression kit 300 within the predetermined time frame, the customer's experience is improved by expediting the overall process, and specifically the process of receiving aligners from the vendor, and ensuring that delays in the customer receiving aligners from the vendor are not caused by the customer.

[0154] The predetermined time frame may ensure that the contents of the dental impression kit 300 are returned at an optimal response rate. For instance, customers may be more likely to return the contents of the dental impression kit 300 in a timely fashion if they are provided with the predetermined time frame, even though the vendor receiving the returned dental impression kit 300 within the predetermined time frame may not be required for the vendor to process and return aligners to the customer. Additionally, the vendor may

be able to plan subsequent processes with more accuracy based on the understanding that the customers will return the contents of their dental impression kit **300** within the predetermined time frame. For instance, where a predetermined time frame for returning the contents of the dental impression kit **300** is not provided, the vendor may ship out several dental impression kits **300** over the course of a month and receive all the contents back from the customers at the end of the month. As a result, subsequent processes performed by the vendor may be slowed down or be backed up due to customer delay. In providing the customer a predetermined time frame for returning the contents of the dental impression kit **300**, both vendor planning and customer experience may be improved.

[0155] In some embodiments, the user may receive one or more messages within the overall process. Such messages may indicate to the user what to expect, what are the next steps, etc. The user may receive these messages as text messages, e-mail messages, phone calls, etc. For instance, the user may receive a kit order confirmation (and/or kit shipment confirmation) when the user orders (or the vendor ships) a dental impression kit **10**. In some embodiments, the user may receive a message following expiration of the predetermined time frame described above indicating that the user still has time for returning their dental impressions. The user may also receive a message when the user successfully uploads the required photos. Additionally or alternatively, the user may receive a message indicating receipt of the impressions from the dental impression kit **10**. In some embodiments, the message may indicate the next steps following one or more of the above occurrences. As one example, the message following receipt of the impressions from the dental impression kit **10** may indicate the next steps (e.g., impression intake process, scanning the impressions directly [or a model generated based on the impressions], digital sculpting of the 3D model, further sculpting and digital occluding, an orthodontics analysis software, generation of a treatment plan, generation of aligners, etc.). In some embodiments, the user may receive a message following each of these steps (e.g., a message following the impression intake process, a message following generation of a treatment plan, etc.). In each of these embodiments, the user may become engaged in the next steps and excited for their aligners.

[0156] In some embodiments, particularly those where the user has a delay in performing one or more steps, the user may receive a message (e.g., an e-mail, a text message, a call, etc.) from a dentist or orthodontist to check up on the user's progress. Such embodiments may alert the user of the delay, thus potentially eliminating bottlenecks and increasing the likelihood that the user will return administered impressions from their dental impression kit **10**. Additionally, such embodiments may increase the number of kit orders by providing a personal touch for the user which the user may discuss with friends, relatives, co-workers, etc.

[0157] The embodiments described above facilitate the application of a dental impression kit at home. It will be appreciated that the dental impression kit and methods described herein have broad applications. The foregoing embodiments were chosen and described in order to illustrate principles of the methods and apparatuses as well as some practical applications. The preceding description enables others skilled in the art to utilize methods and apparatuses in various embodiments and with various modi-

fications as are suited to the particular use contemplated. In accordance with the provisions of the patent statutes, the principles and modes of operation of this disclosure have been explained and illustrated in exemplary embodiments.

[0158] It is intended that the scope of the present methods and apparatuses be defined by the following claims. However, it must be understood that this disclosure may be practiced otherwise than is specifically explained and illustrated without departing from its spirit or scope. It should be understood by those skilled in the art that various alternatives to the embodiments described herein may be employed in practicing the claims without departing from the spirit and scope as defined in the following claims.

What is claimed is:

1. A dental impression kit comprising:

a container including a dental assembly, the dental assembly including a dental tray, a predetermined amount of base putty, and a predetermined amount of catalyst putty, the base putty and the catalyst putty being mixable to form a putty mixture, the predetermined amount of base putty and the predetermined amount of catalyst putty are amounts sufficient such that the putty mixture can be positioned in the dental tray for creating a dental impression; and

instructions instructing a user to:

mix the predetermined amount of base putty and the predetermined amount of catalyst putty to form the putty mixture;
position the putty mixture in the dental tray;
position the dental tray with the putty mixture in the user's mouth to create the dental impression; and
return the dental assembly including the dental impression;

wherein the dental impression provides information necessary to manufacture a plurality of dental aligners specific to the user and being configured to reposition one or more teeth of the user; and

wherein the predetermined amount of base putty is in the range of 0.5 ounces and 1.5 ounces and the predetermined amount of catalyst putty is in the range of 0.5 ounces and 1.5 ounces.

2. The dental impression kit of claim 1, wherein the predetermined amount of base putty is in the range of 0.88 ounces and 0.92 ounces and the predetermined amount of catalyst putty is in the range of 0.88 ounces and 0.92 ounces.

3. The dental impression kit of claim 1, wherein the predetermined amount of base putty is in the range of 0.80 ounces and 0.90 ounces and the predetermined amount of catalyst putty is in the range of 0.80 ounces and 0.90 ounces.

4. The dental impression kit of claim 1, wherein the predetermined amount of base putty is an amount greater than the predetermined amount of catalyst putty.

5. The dental impression kit of claim 1, wherein the predetermined amount of catalyst putty is an amount greater than the predetermined amount of base putty.

6. The dental impression kit of claim 1, wherein the predetermined amount of catalyst putty is the same amount as the predetermined amount of base putty.

7. The dental impression kit of claim 1, wherein the predetermined amount of catalyst putty is substantially the same amount as the predetermined amount of base putty.

8. The dental impression kit of claim 1, wherein the predetermined amount of catalyst putty and the predetermined amount of base putty are each separately contained in

respective putty containers, the putty containers sealed by at least one of plastic film, foil, glue, a snap seal cap.

9. The dental impression kit of claim 1, wherein the predetermined amount of catalyst putty and the predetermined amount of base putty are each separately contained in respective putty cups, wherein the putty cups are hermetically sealed.

10. The dental impression kit of claim 1, wherein the dental assembly is a first dental assembly, and wherein the container further includes a second dental assembly including a second dental tray, an additional predetermined amount of catalyst putty, and an additional predetermined amount of base putty, and wherein the instructions further instruct the user to:

mix the additional predetermined amount of catalyst putty mixture with the additional predetermined amount of base to form additional putty mixture;

position the additional putty mixture in the second dental tray; and

position the second dental tray in the user's mouth to create a second dental impression in the additional putty mixture.

11. The dental impression kit of claim 10, wherein the first dental assembly is an initial dental assembly for creating an initial dental impression of a first dental arch of the user, and wherein the second dental assembly is a redundant dental assembly for creating a redundant dental impression of the first dental arch of the user.

12. The dental impression kit of claim 10, wherein the first dental assembly is for creating a dental impression of a first dental arch of the user, and wherein the second dental assembly is for creating a dental impression of a second dental arch of the user.

13. The dental impression kit of claim 12, wherein the first dental assembly is of a first specific size to create a dental impression of an upper dental arch of the user, and wherein the second dental assembly is of a second specific size to create a dental impression of a lower dental arch of the user.

14. A method of administering a dental impression kit, the method comprising:

receiving a container including a dental assembly, the dental assembly including a dental tray, a predetermined amount of base putty, and a predetermined amount of catalyst putty, the base putty and the catalyst putty being mixable to form a putty mixture, the predetermined amount of base putty and the predetermined amount of catalyst putty are amounts sufficient such that the putty mixture can be positioned in the dental tray for creating a dental impression; and

mixing the predetermined amount of base putty and the predetermined amount of catalyst putty to form the putty mixture according to instructions;

positioning the putty mixture in the dental tray according to the instructions;

positioning the dental tray with the putty mixture in a user's mouth to create the dental impression according to the instructions; and

returning the dental assembly including the dental impression according to the instructions;

wherein the dental impression provides information necessary to manufacture a plurality of dental aligners specific to the user and being configured to reposition one or more teeth of the user; and

wherein the predetermined amount of base putty is in the range of 0.5 ounces and 1.5 ounces and the predetermined amount of catalyst putty is in the range of 0.5 ounces and 1.5 ounces.

15. The method of claim 14, wherein the predetermined amount of base putty is in the range of 0.88 ounces and 0.92 ounces and the predetermined amount of catalyst putty is in the range of 0.88 ounces and 0.92 ounces.

16. The method of claim 14, wherein the predetermined amount of base putty is in the range of 0.80 ounces and 0.90 ounces and the predetermined amount of catalyst putty is in the range of 0.80 ounces and 0.90 ounces.

17. The method of claim 14, wherein the predetermined amount of base putty is an amount greater than the predetermined amount of catalyst putty.

18. The method of claim 14, wherein the predetermined amount of catalyst putty is an amount greater than the predetermined amount of base putty.

19. The method of claim 14, wherein the predetermined amount of catalyst putty is the same amount as the predetermined amount of base putty.

20. The method of claim 14, wherein the predetermined amount of catalyst putty is substantially the same the amount as the predetermined amount of base putty.

21. The method of claim 14, wherein the predetermined amount of catalyst putty and the predetermined amount of base putty are each separately contained in respective putty containers, the putty containers sealed by at least one of plastic film, foil, glue, a snap seal cap.

22. The method of claim 14, wherein the predetermined amount of catalyst putty and the predetermined amount of base putty are each separately contained in respective putty cups, wherein the putty cups are hermetically sealed.

23. The method of claim 14, further comprising receiving the plurality of dental aligners specific to the user and being configured to reposition one or more teeth of the user.

24. A dental impression kit comprising:

a container including a first dental assembly and a second dental assembly, the first dental assembly and the second dental assembly each including a dental tray, a predetermined amount of base putty, and a predetermined amount of catalyst putty, the base putty and the catalyst putty being mixable to form a putty mixture, the predetermined amount of base putty and the predetermined amount of catalyst putty are amounts sufficient such that the putty mixture can be positioned in one of the dental trays for creating a dental impression; and

instructions instructing a user to, for each of the first dental assembly and the second dental assembly:

mix the predetermined amount of base putty and the predetermined amount of catalyst putty to form the putty mixture;

position the putty mixture in the dental tray;

position the dental tray with the putty mixture in the user's mouth to create the dental impression; and

return the dental assembly including the dental impression;

wherein the dental impressions provide information necessary to manufacture a plurality of dental aligners specific to the user and being configured to reposition one or more teeth of the user; and

wherein the predetermined amount of base putty is in the range of 0.5 ounces and 1.5 ounces and the predetermined amount of catalyst putty is in the range of 0.5 ounces and 1.5 ounces.

25. The dental impression kit of claim **24**, wherein the predetermined amount of base putty is in the range of 0.88 ounces and 0.92 ounces and the predetermined amount of catalyst putty is in the range of 0.88 ounces and 0.92 ounces.

26. The dental impression kit of claim **24**, wherein the first dental assembly is an initial dental assembly for creating an initial dental impression of one of an upper dental arch of the user or a lower dental arch of the user, and wherein the second dental assembly is a redundant dental assembly for creating a redundant dental impression of the one of an upper dental arch of the user or a lower dental arch of the user.

27. The dental impression kit of claim **24**, wherein the first dental assembly is for creating a dental impression of a first

dental arch of the user, and wherein the second dental assembly is for creating a dental impression of a second dental arch of the user.

28. The dental impression kit of claim **27**, wherein the first dental arch of the user and the second dental arch of the user are the same dental arch of the user.

29. The dental impression kit of claim **27**, wherein the dental tray of the first dental assembly is of a first specific size to create a dental impression of an upper dental arch of the user, and wherein the dental tray of the second dental assembly is of a second specific size to create a dental impression of a lower dental arch of the user.

30. The dental impression kit of claim **29**, wherein the predetermined amount of base putty and the predetermined amount of catalyst putty for the first dental assembly is greater than the predetermined amount of base putty and the predetermined amount of catalyst putty for the second dental assembly.

* * * * *