



US012004088B2

(12) **United States Patent**
Ying et al.

(10) **Patent No.:** **US 12,004,088 B2**
(45) **Date of Patent:** **Jun. 4, 2024**

(54) **NETWORK COORDINATION FOR
CROSSLINK INTERFERENCE MITIGATION**

(71) Applicant: **Apple Inc.**, Cupertino, CA (US)

(72) Inventors: **Dawei Ying**, Cupertino, CA (US);
Hassan Ghozlan, Cupertino, CA (US);
Qian Li, Cupertino, CA (US); **Geng
Wu**, Cupertino, CA (US)

(73) Assignee: **Apple Inc.**, Cupertino, CA (US)

(*) Notice: Subject to any disclaimer, the term of this
patent is extended or adjusted under 35
U.S.C. 154(b) by 303 days.

(21) Appl. No.: **17/421,786**

(22) PCT Filed: **Jan. 11, 2020**

(86) PCT No.: **PCT/US2020/013250**

§ 371 (c)(1),
(2) Date: **Jul. 9, 2021**

(87) PCT Pub. No.: **WO2020/146851**

PCT Pub. Date: **Jul. 16, 2020**

(65) **Prior Publication Data**

US 2022/0095240 A1 Mar. 24, 2022

Related U.S. Application Data

(60) Provisional application No. 62/791,698, filed on Jan.
11, 2019.

(51) **Int. Cl.**
H04W 52/00 (2009.01)
H04B 17/336 (2015.01)

(Continued)

(52) **U.S. Cl.**
CPC **H04W 52/243** (2013.01); **H04B 17/336**
(2015.01); **H04W 24/10** (2013.01); **H04W**
52/146 (2013.01); **H04W 52/367** (2013.01)

(58) **Field of Classification Search**
CPC . H04W 52/243; H04W 24/10; H04W 52/146;
H04W 52/367; H04B 17/336
See application file for complete search history.

(56) **References Cited**

U.S. PATENT DOCUMENTS

2020/0228212 A1* 7/2020 Xu H04L 5/14
2021/0050983 A1* 2/2021 Manolakos H04L 5/0048
(Continued)

FOREIGN PATENT DOCUMENTS

CN 103458435 A 12/2013

OTHER PUBLICATIONS

Huawei et al.: "UE-to-UE measurement for cross-link interference
mitigation", 3GPP Draft; R1-1712178, 3rd Generation Partnership
Project (3GPP), Mobile Competence Centre; 650, Route Des Lucioles;
F-06921 Sophia-Antipolis Cedex; France, vol. RAN WG1, No.
Prague, Czech Republic; Aug. 21, 2017-Aug. 25, 2017, Aug. 20,
2017, XP051314995.

(Continued)

Primary Examiner — Erika A Washington
(74) *Attorney, Agent, or Firm* — Sterne, Kessler,
Goldstein & Fox P.L.L.C.

(57) **ABSTRACT**

Disclosed herein are system, method, and computer program
product embodiments for identifying an aggressor device or
an aggressor beam of an aggressor device. The embodiments
further mitigate the impact of the identified aggressor device
or the identified aggressor beam of the aggressor device.

20 Claims, 17 Drawing Sheets

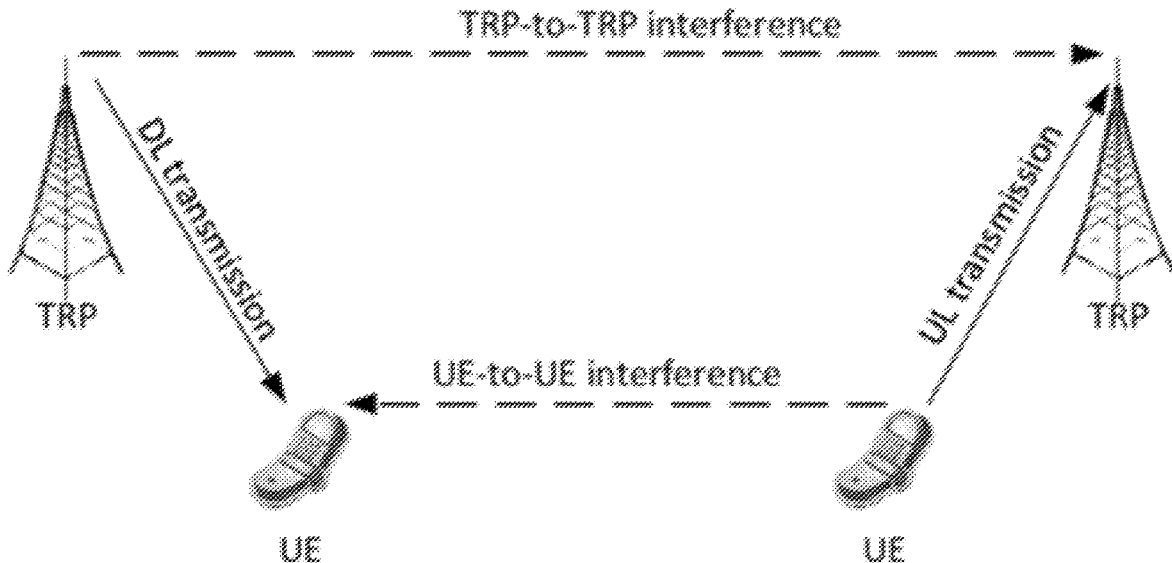

- (51) **Int. Cl.**
- H04W 24/10* (2009.01)
- H04W 52/14* (2009.01)
- H04W 52/24* (2009.01)
- H04W 52/36* (2009.01)

International Search Report and Written Opinion of the International Searching Authority directed to related International Patent Application No. PCT/US2020/013250, dated Jul. 1, 2020, 15 pages. SAMSUNG: Discussion on joint CLI measurement and beam management11 , 3GPP Draft; R1-1720307, 3rd Generation Partnership Project (3GPP) vol. RAN WGI, No. Reno, USA; Nov. 27, 2017-Dec. 1, 2017, Nov. 17, 2017 (Nov. 17, 2017), XP051368955, Retrieved from the Internet: URL:<http://www.3gpp.org/ftp/tsg%5Fran/WG1%5FRL1/TSGR1%5F91/Docs/> [retrieved on Nov. 17, 2017].

(56) **References Cited**

U.S. PATENT DOCUMENTS

- 2023/0136620 A1* 5/2023 Nam H04B 7/0695
370/252
- 2023/0164701 A1* 5/2023 Fakoorian H04W 52/58
455/522

SAMSUNG: Joint CLI Mitigation and beam management 11, 3GPP Draft; R1-1716035, 3rd Generation Partnership Project (3GPP) ' vol. RAN WGI, No. Nagoya, Japan; Sep. 18, 2017-Sep. 21, 2017, Sep. 17, 2017 (Sep. 17, 2017), XP0513 39494, Retrieved from the Internet: URL:[http://www.3gpp.org/ftp/Meetings-3GPP-SYNC/RAN/ Docs/](http://www.3gpp.org/ftp/Meetings-3GPP-SYNC/RAN/Docs/) [retrieved on Sep. 17, 2017].

OTHER PUBLICATIONS

Extended European Search Report directed to related European Application No. 23186272.3, dated Oct. 16, 2023; 7 pages.

3GPP, "3rd Generation Partnership Project; Technical Specification Group Radio Access Network; Study on New Radio Access Technology Physical Layer Aspects (Release 14)," 3GPP TR 38.802 V14.0.0, Mar. 2017, 143 pages.

* cited by examiner

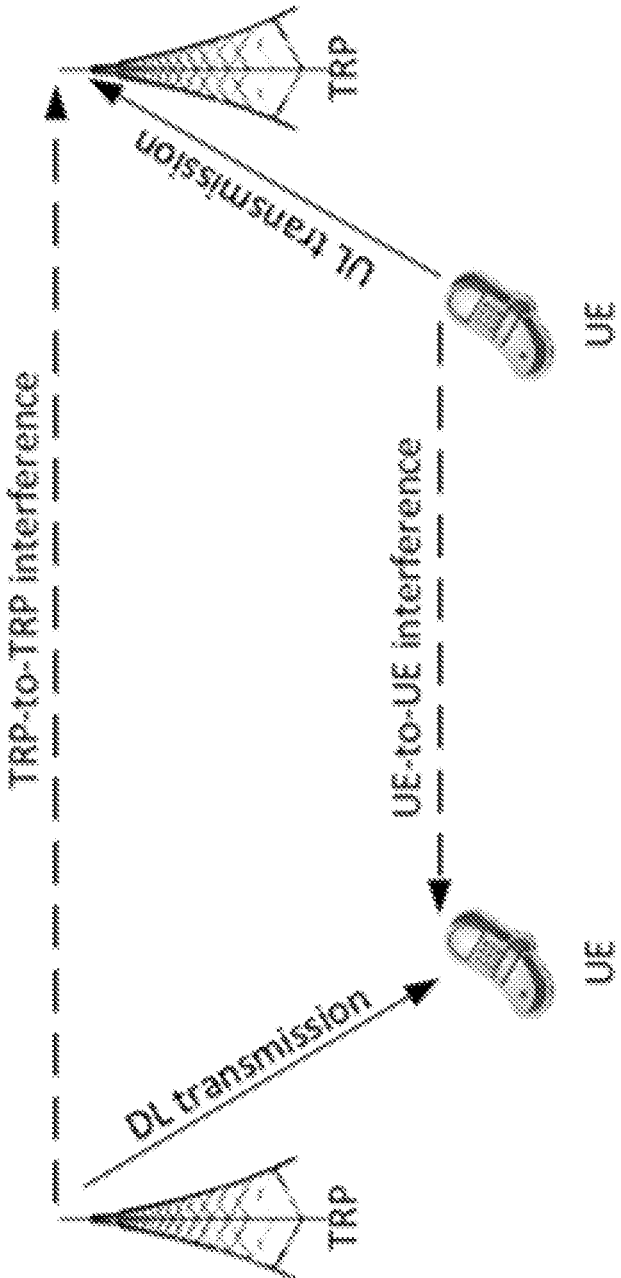

FIG. 1

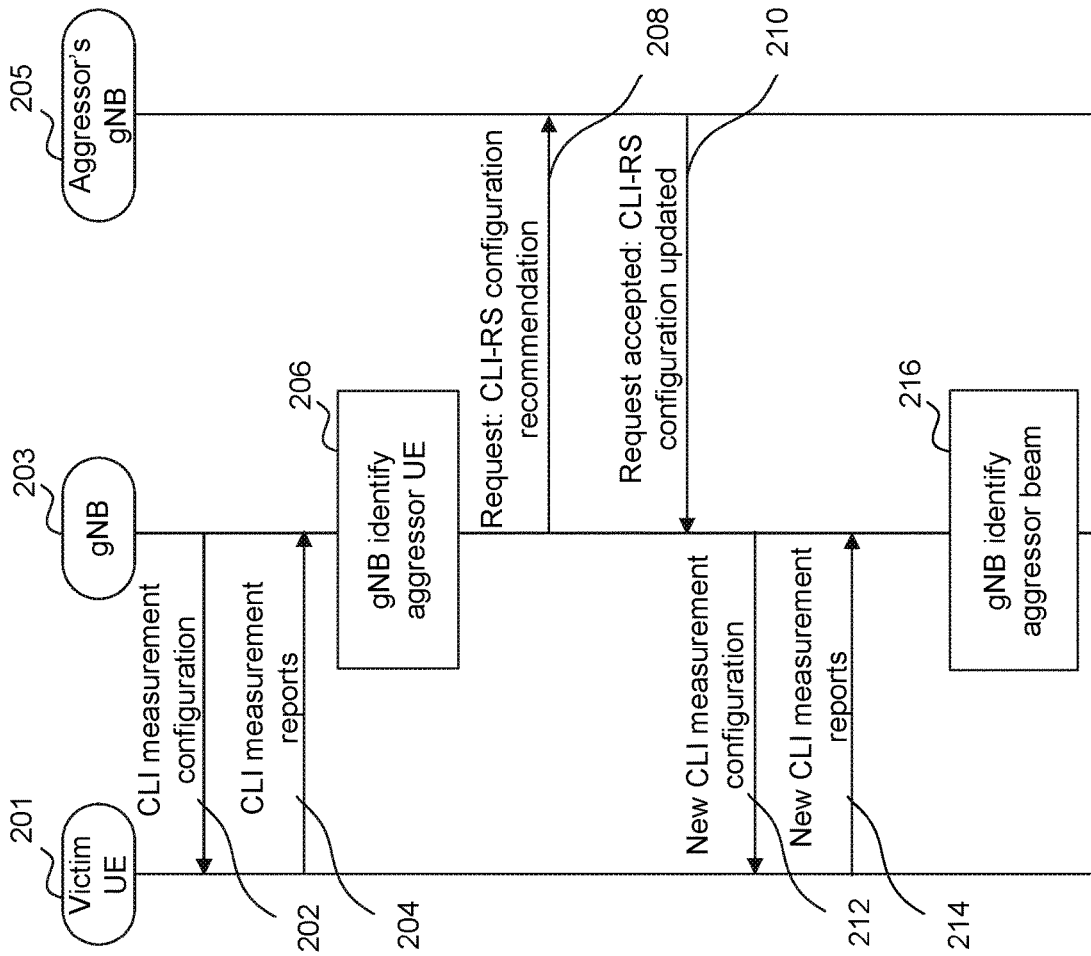

FIG. 2

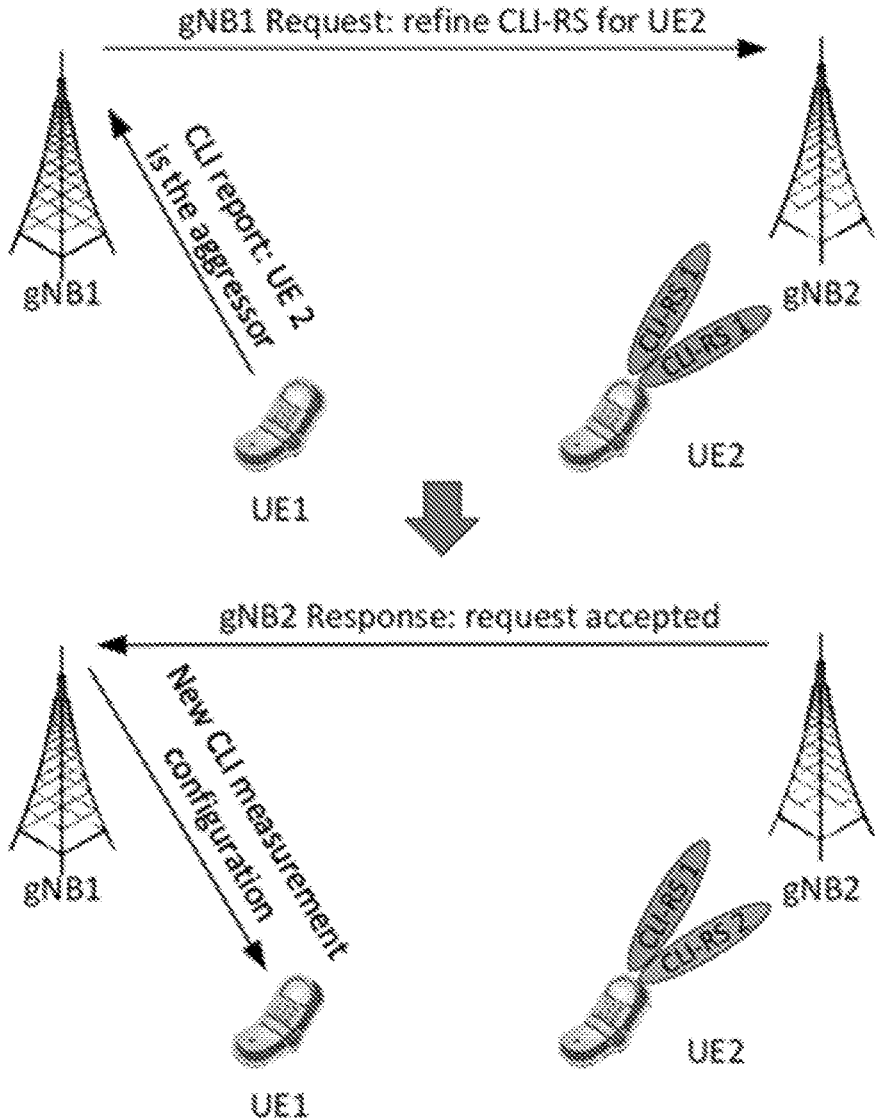

FIG. 3

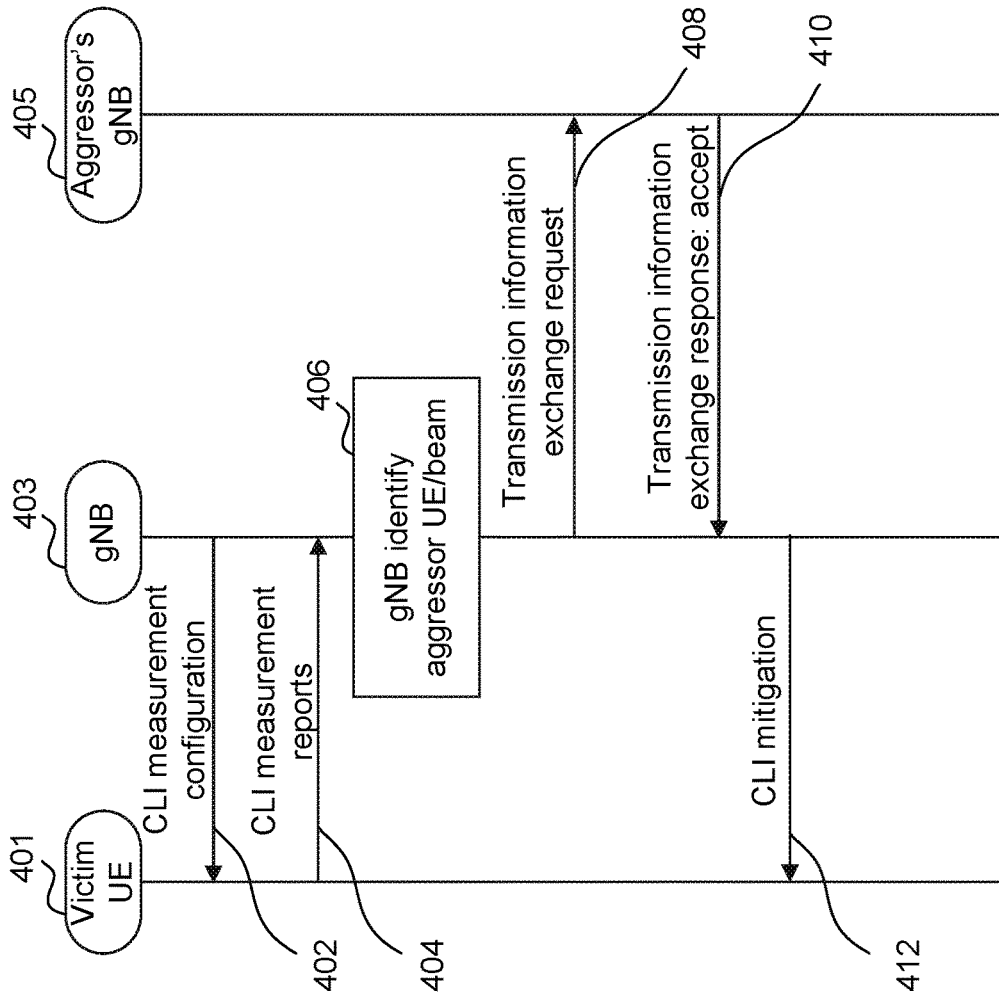

FIG. 4

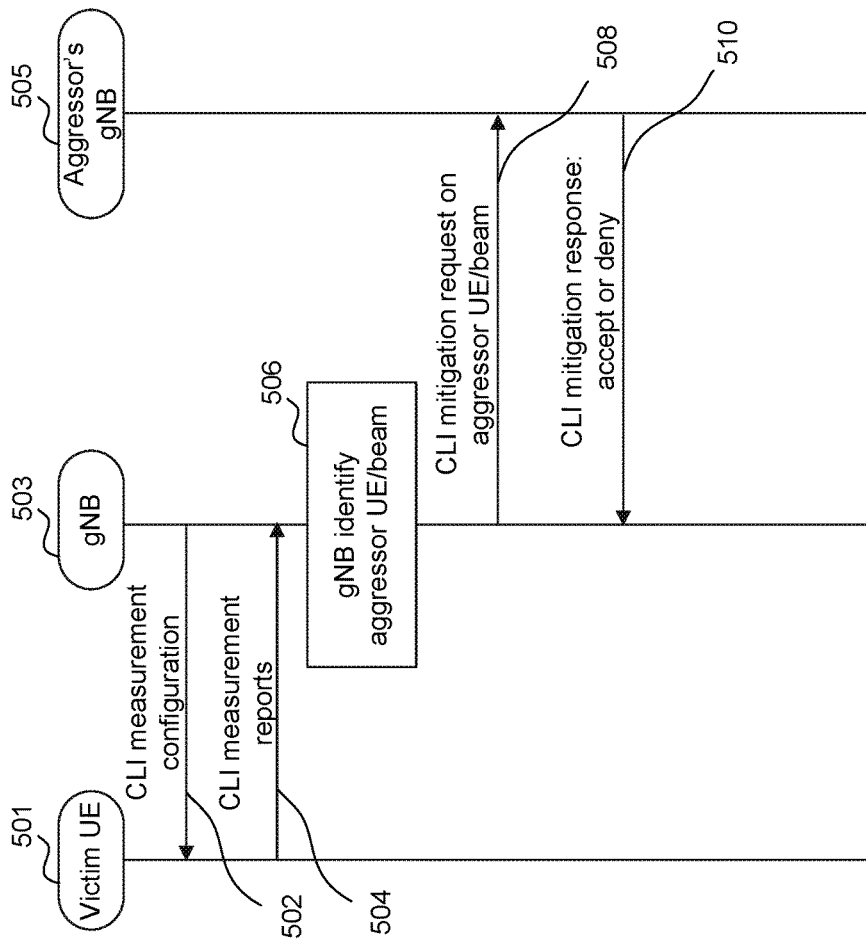

FIG. 5

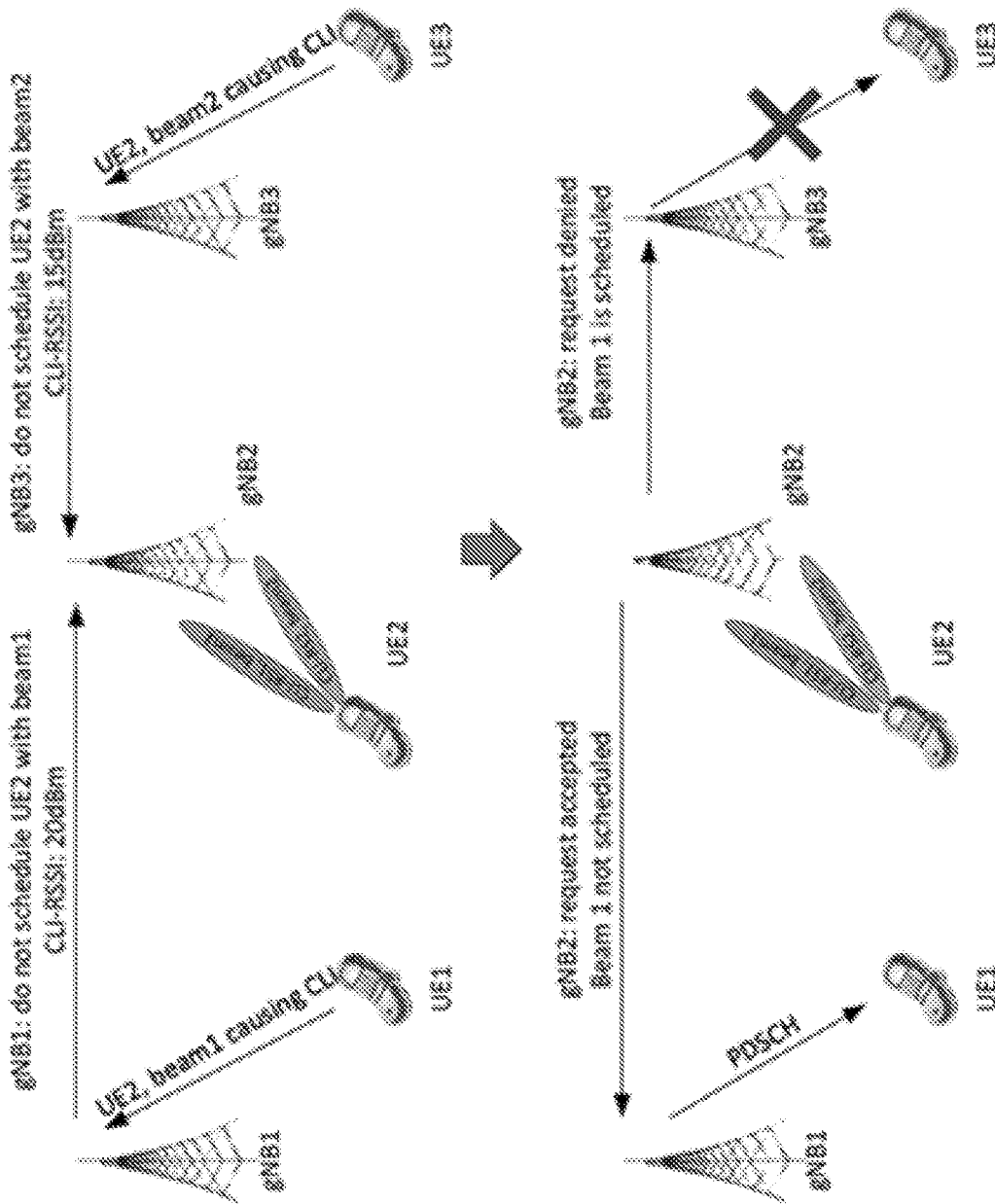

FIG. 6

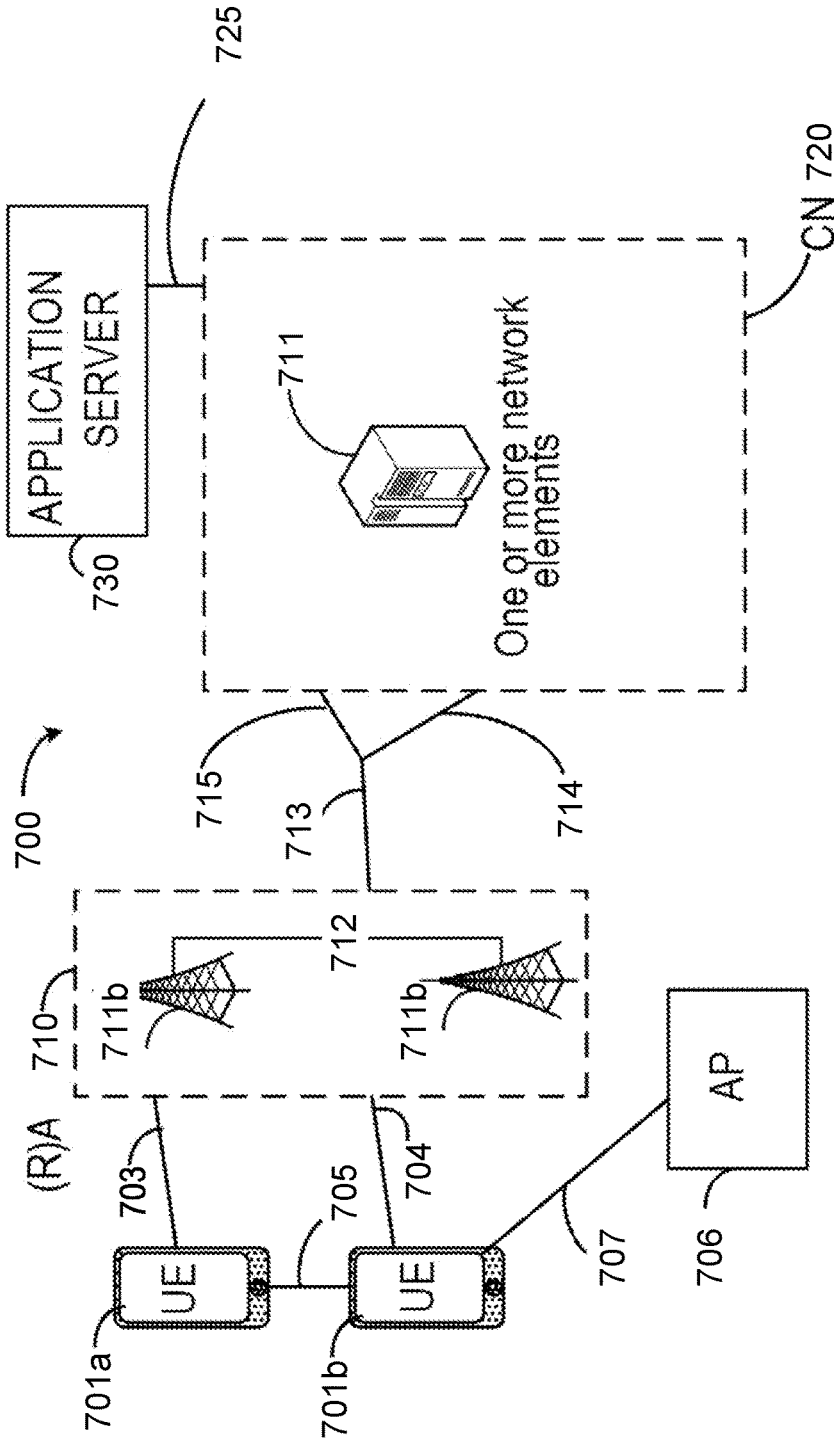

FIG. 7

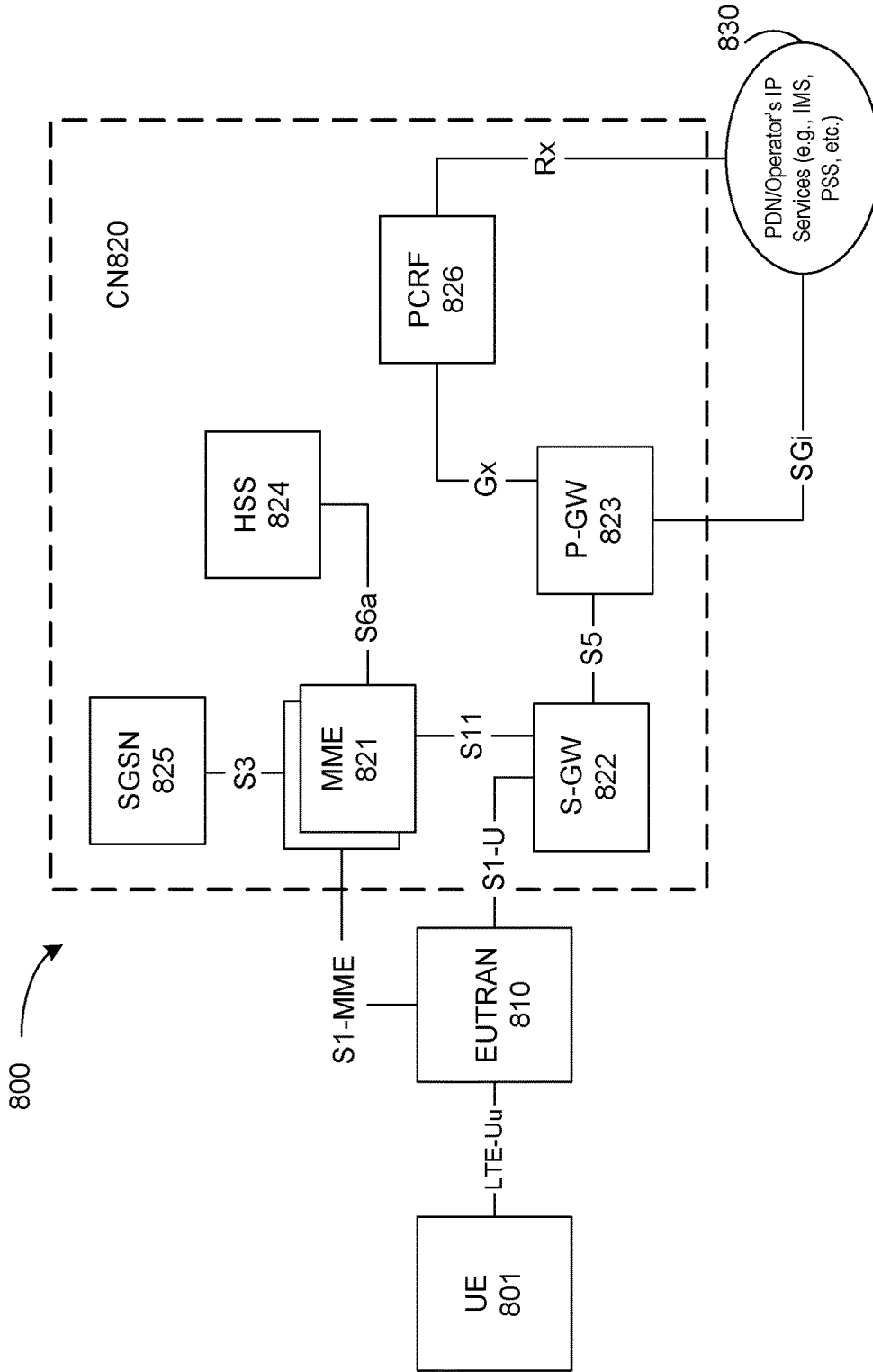

FIG. 8

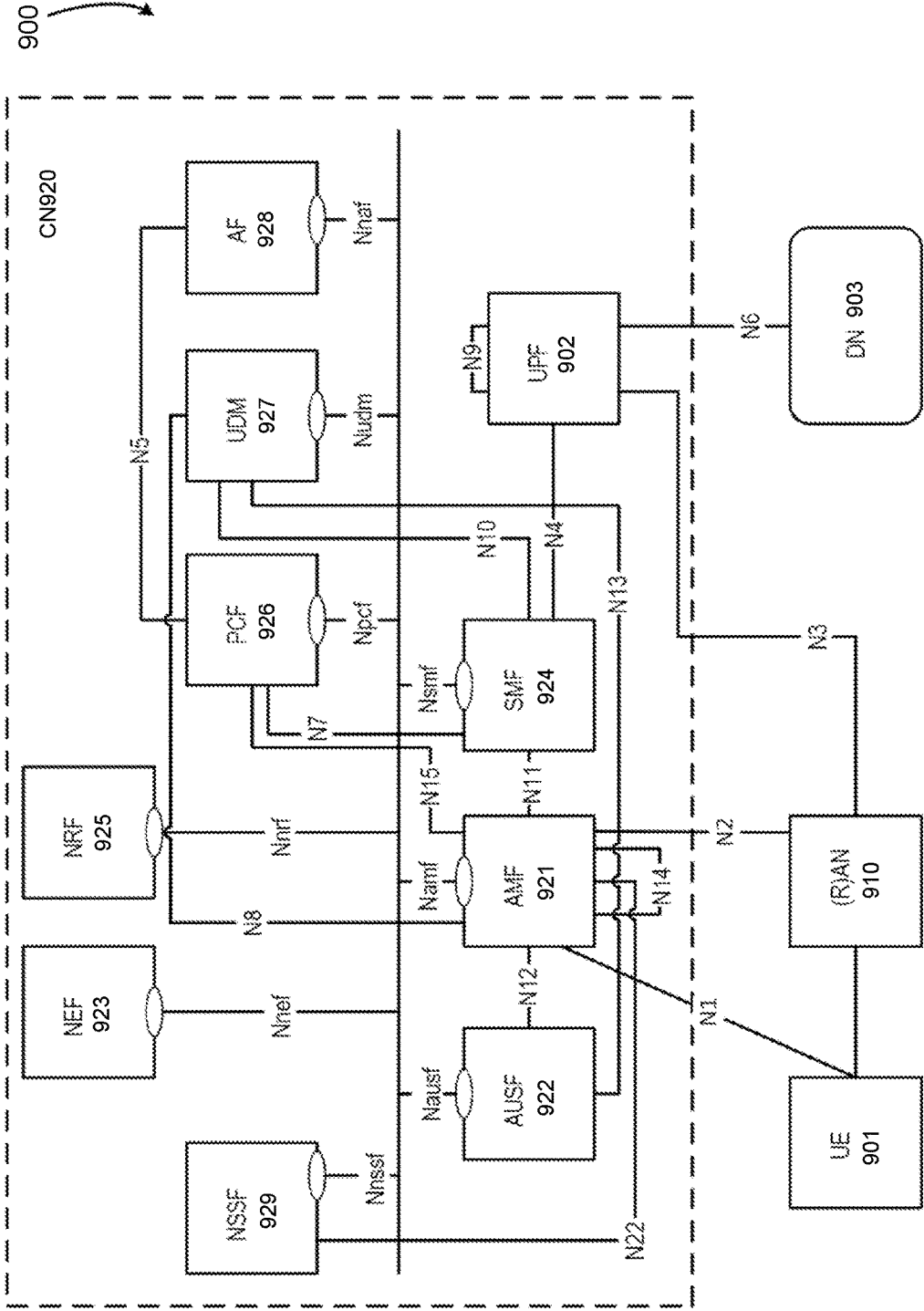

FIG. 9

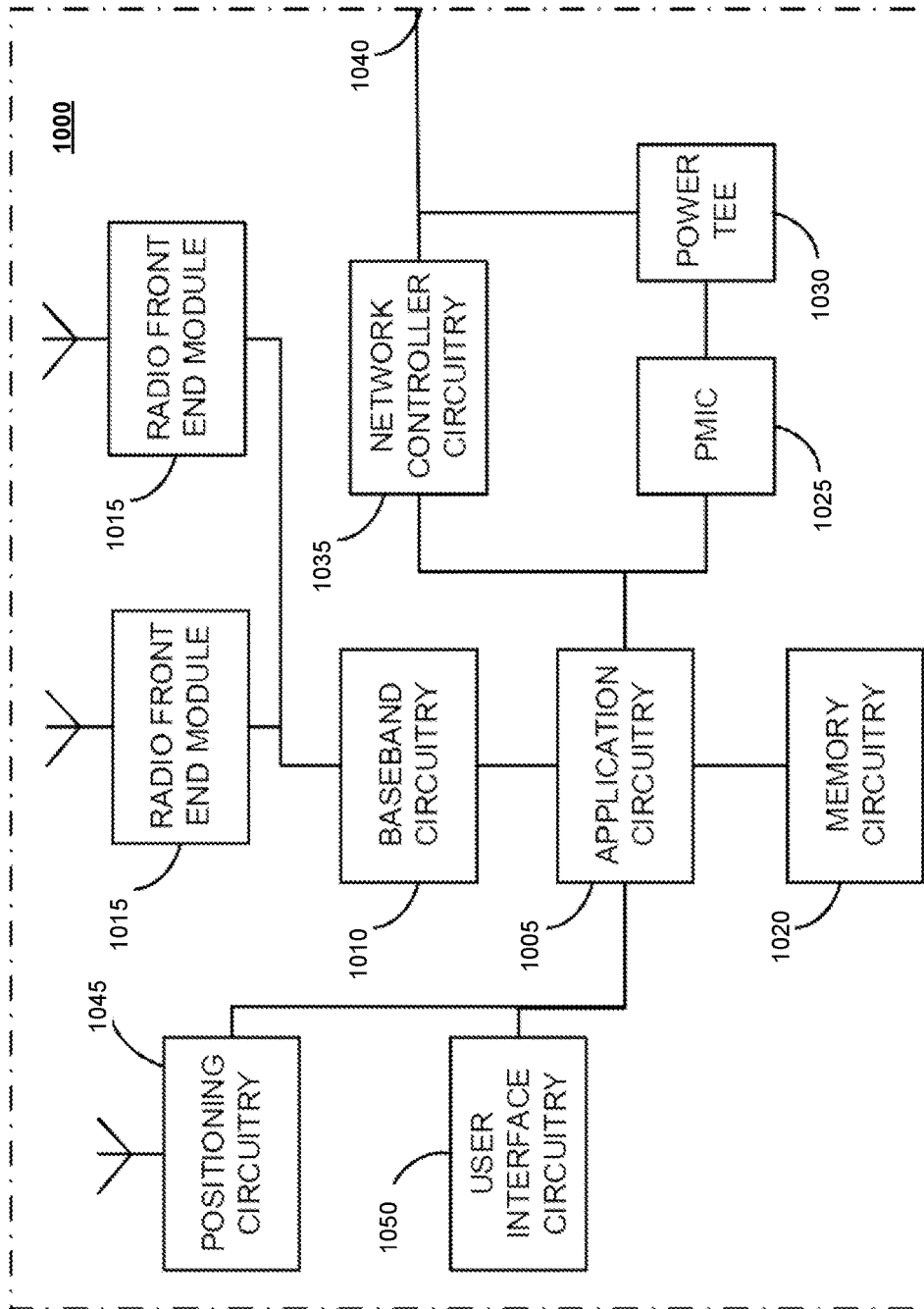

FIG. 10

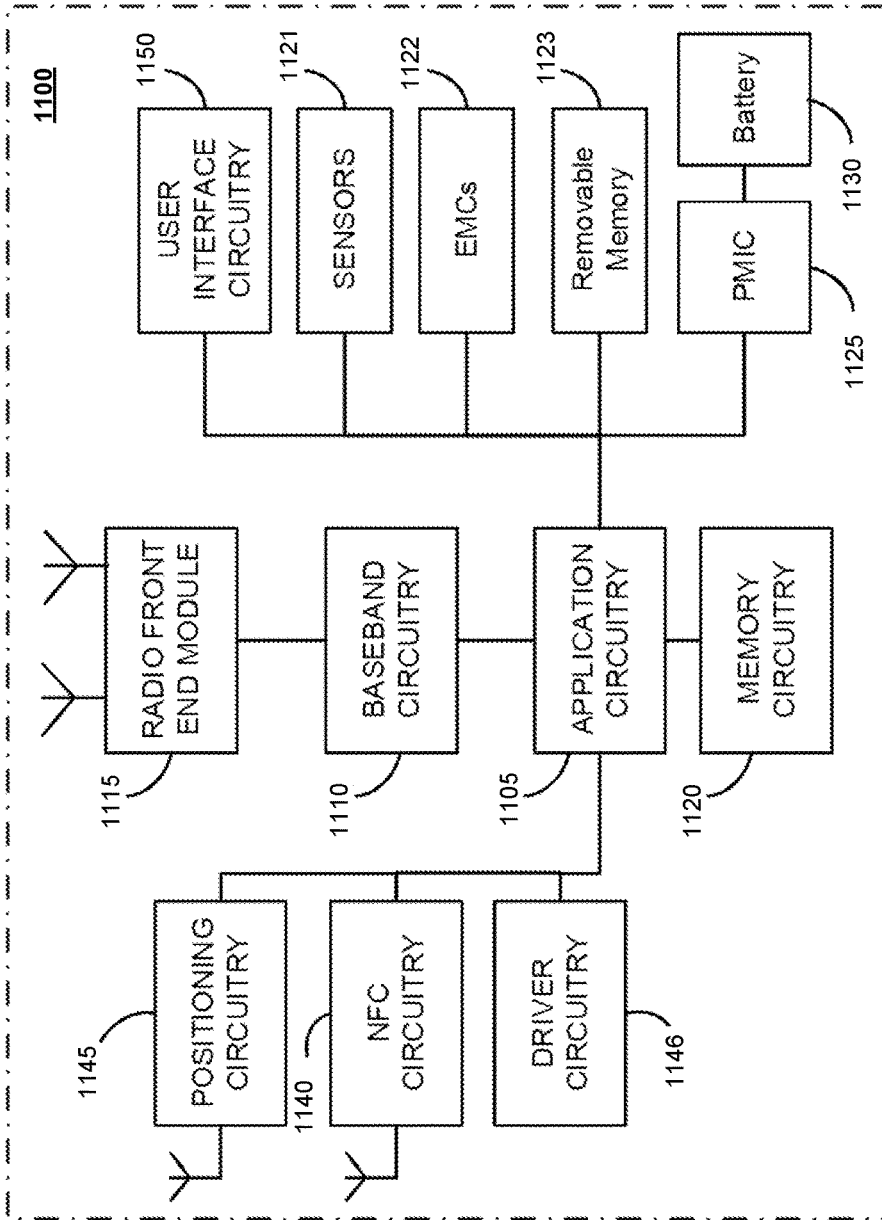

FIG. 11

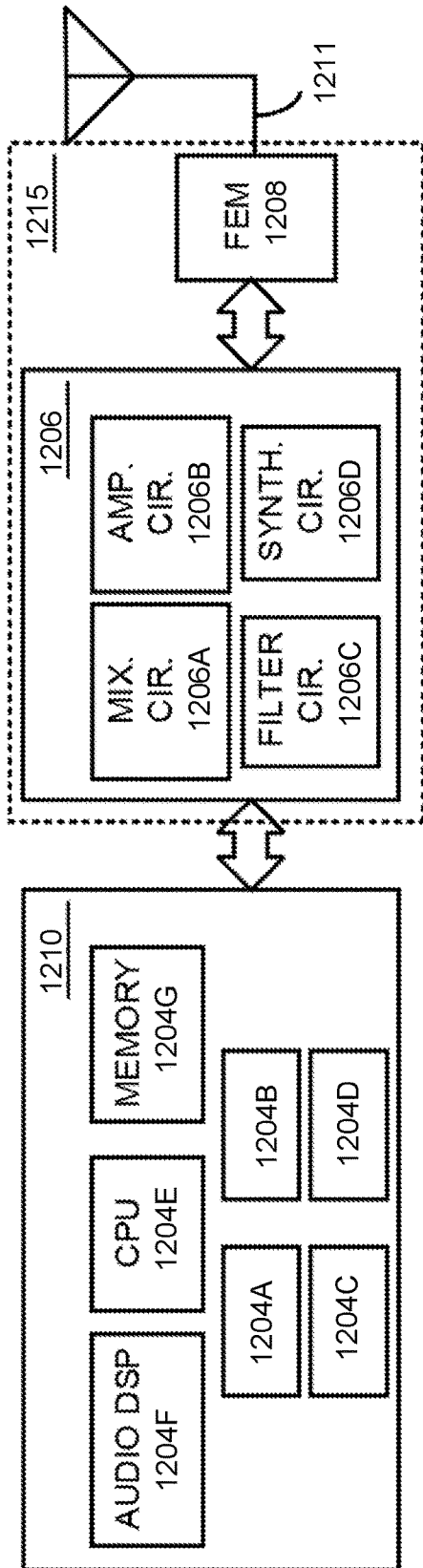

FIG. 12

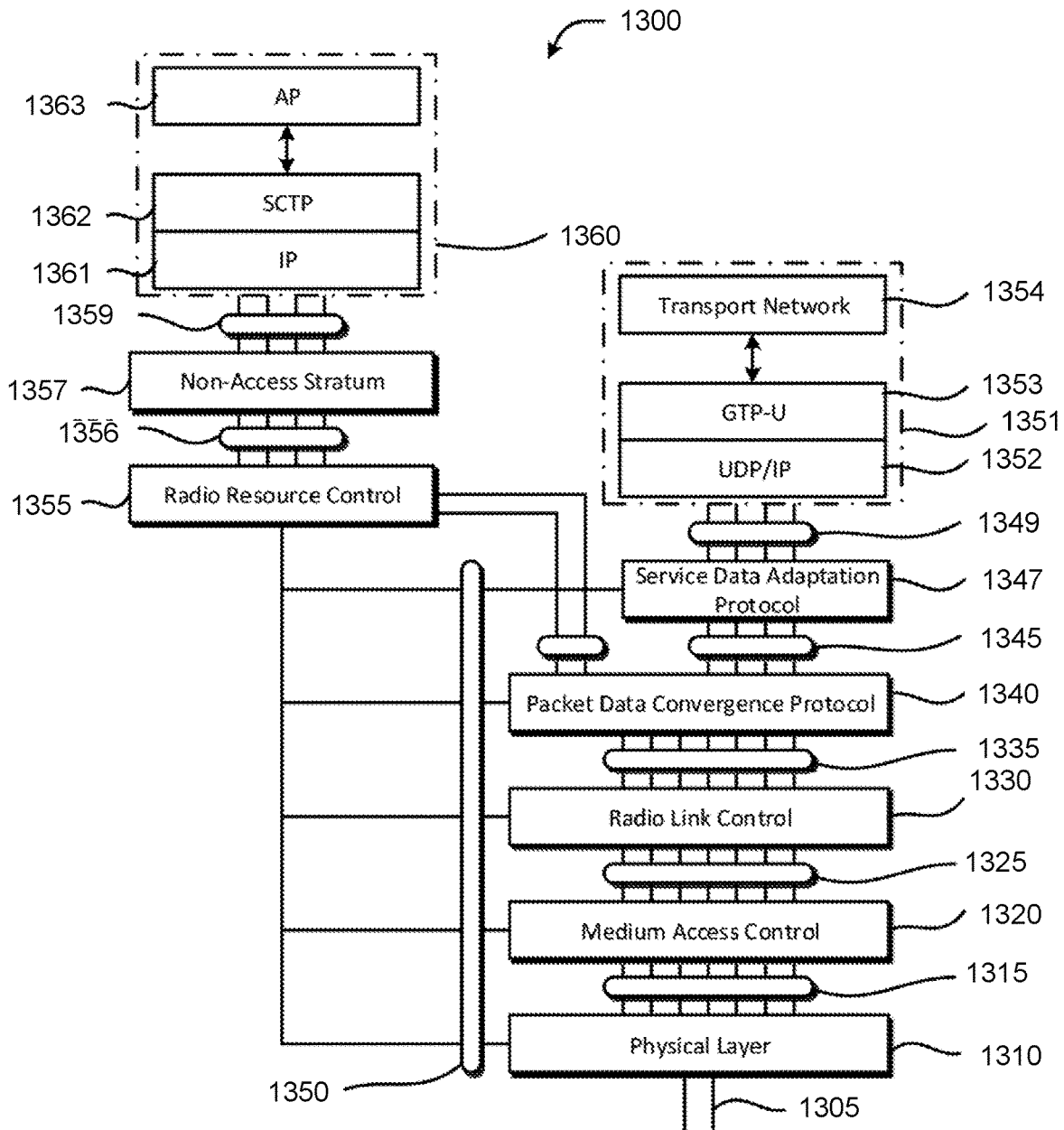

FIG. 13

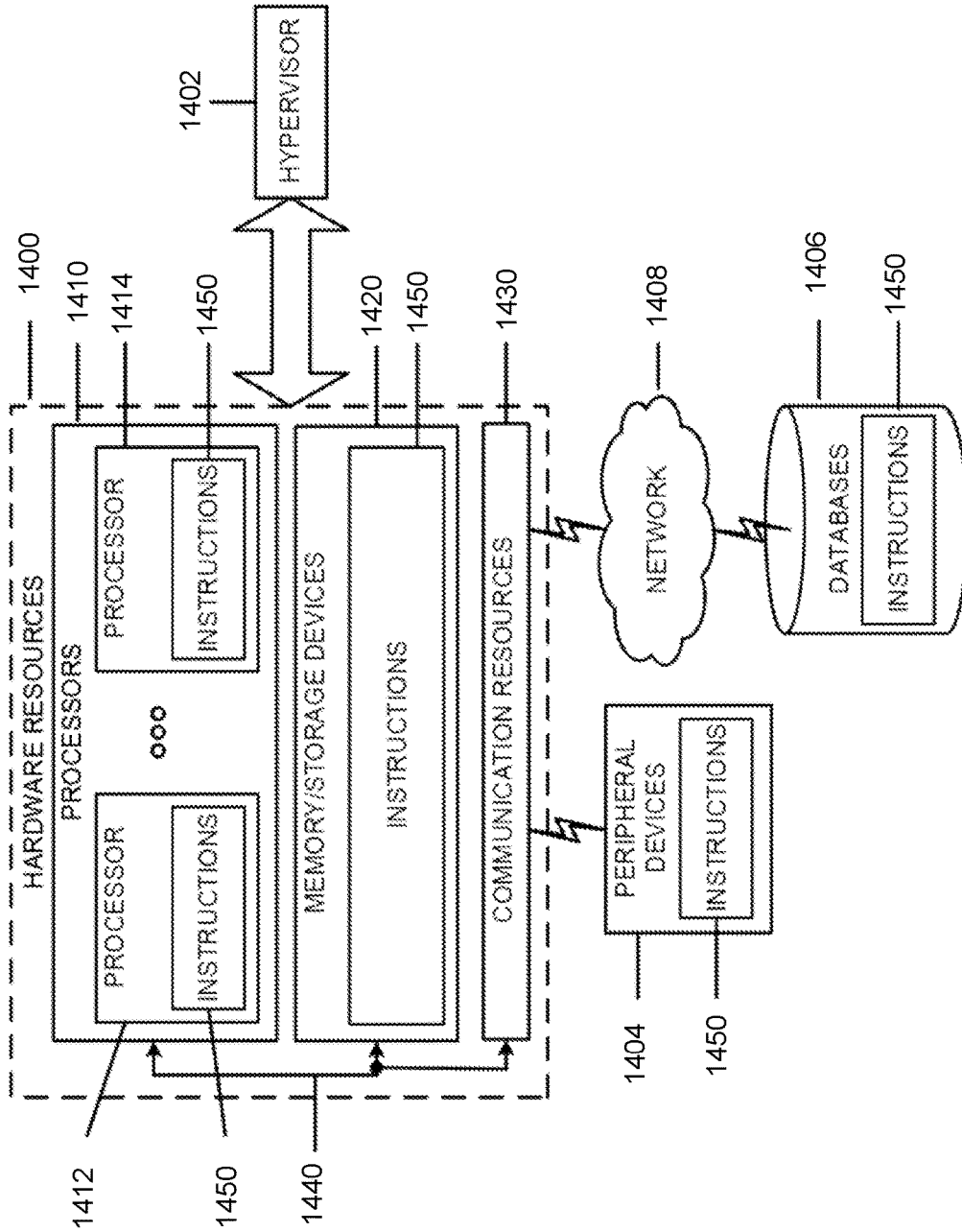

FIG. 14

1500

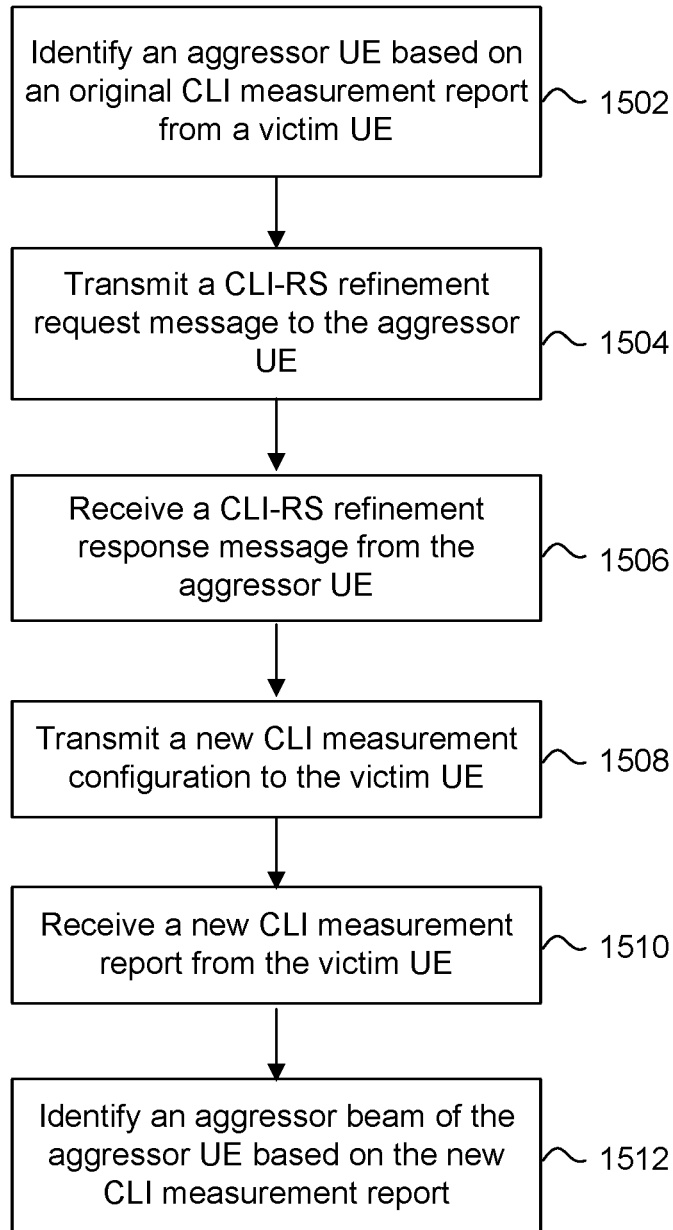

FIG. 15

1600

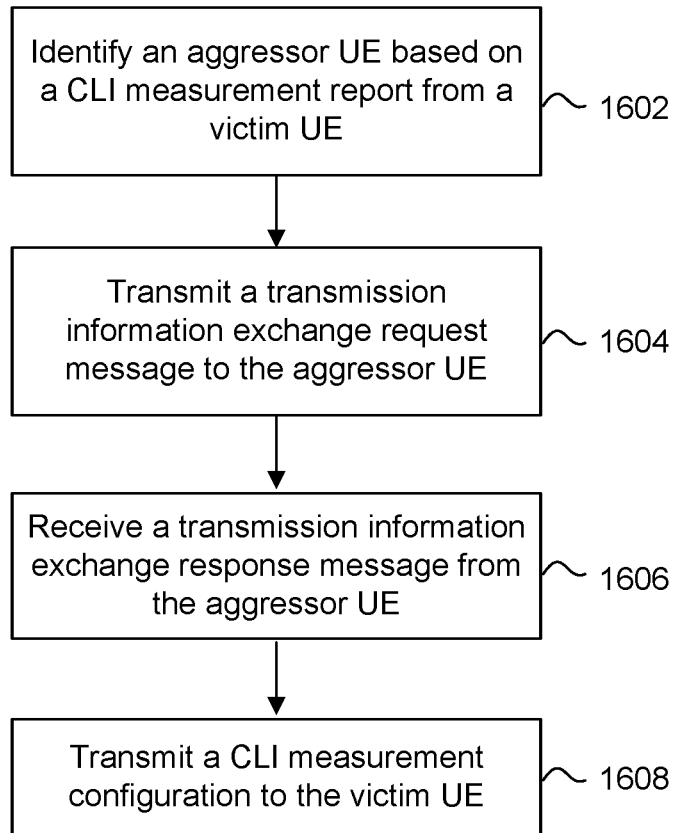

FIG. 16

1700

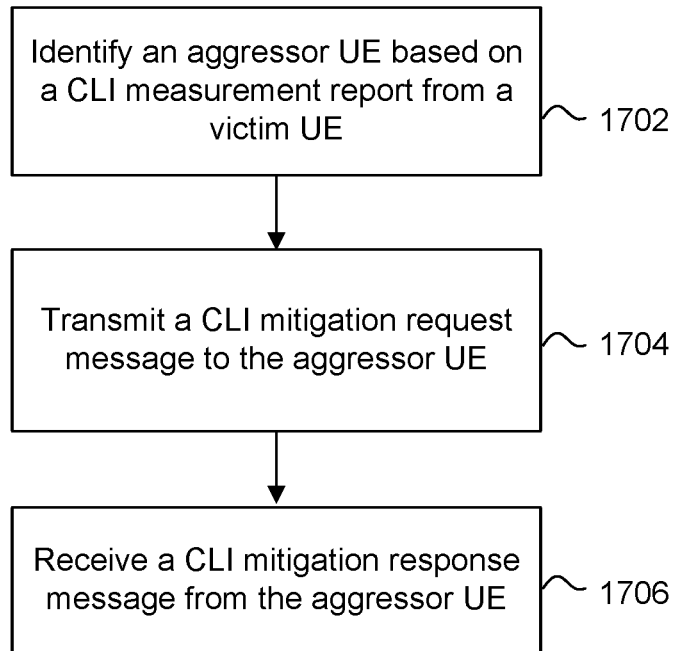

FIG. 17

NETWORK COORDINATION FOR CROSSLINK INTERFERENCE MITIGATION

CROSS REFERENCE TO RELATED APPLICATIONS

This application is a U.S. National Phase of International Application No. PCT/US2020/013250, filed Jan. 11, 2020, which claims the benefit under 35 U.S.C. § 119(e) of U.S. Provisional Application No. 62/791,698, filed Jan. 11, 2019, both of which are hereby incorporated by reference in their entireties.

BACKGROUND

Various embodiments generally may relate to the field of wireless communications.

SUMMARY

Disclosed herein are system, method, and computer program product embodiments for identifying and mitigating the impact of an aggressor device or an aggressor beam of an aggressor device.

Some embodiments are directed to a method of mitigating an aggressor device, including identifying the aggressor device based at least in part on an original crosslink interference (CLI) measurement report from a victim device, and transmitting a CLI Reference Signal (CLI-RS) refinement request message to the aggressor device, wherein the CLI-RS refinement request message comprises an identifier for the aggressor device. The method further includes receiving a CLI-RS refinement response message from the aggressor device, wherein the CLI-RS refinement response message comprises an indication that the CLI-RS refinement request message was accepted by the aggressor device, and transmitting an updated CLI measurement configuration to the victim device based at least in part on the CLI-RS refinement response message.

Some embodiments are directed to a UE including processing circuitry and radio front end circuitry. The processing circuitry can be configured to identify an aggressor device based on an original crosslink interference (CLI) measurement report from a victim device. The processing circuitry can be configured to transmit, via the radio front end circuitry, a CLI Reference Signal (CLI-RS) refinement request message to the aggressor device. The processing circuitry can be configured to receive, via the radio front end circuitry, a CLI-RS refinement response message from the aggressor device. The CLI-RS refinement response message can include an indication that the CLI-RS refinement request message was accepted by the aggressor device. The processing circuitry can be configured to transmit, via the radio front end circuitry, an updated CLI measurement configuration to the victim device. The processing circuitry can be configured to receive, via the radio front end circuitry, an updated CLI measurement report from the victim device. The processing circuitry can be configured to identify an aggressor beam of the aggressor device based on the updated CLI measurement report.

Some embodiments are directed to a UE including processing circuitry and radio front end circuitry. The processing circuitry can be configured to identify an aggressor device based on a CLI measurement report from a victim device. The processing circuitry can be configured to transmit, via the radio front end circuitry, a transmission information exchange request message to the aggressor device.

The processing circuitry can be configured to receive, via the radio front end circuitry, a transmission information exchange response message from the aggressor device. The transmission information exchange response message can include an indication that the transmission information exchange request message was accepted by the aggressor device. The transmission information exchange response message can further include transmission information for the aggressor device. The processing circuitry can be configured to transmit, via the radio front end circuitry, a CLI mitigation request message to the victim device based on the transmission information for the aggressor device.

Some embodiments are directed to a UE including processing circuitry and radio front end circuitry. The processing circuitry can identify an aggressor device based on a CLI measurement report from a victim device. The processing circuitry can be configured to transmit, via the radio front end circuitry, a CLI mitigation request message to the aggressor device. The processing circuitry can be configured to receive, via the radio front end circuitry, a CLI mitigation response message from the aggressor device. The CLI mitigation response message can include an indication that the CLI mitigation request message was accepted by the aggressor device. The CLI mitigation response message can further include transmission information for the aggressor device.

BRIEF DESCRIPTION OF THE DRAWINGS/FIGURES

FIG. 1 illustrates user equipment to user equipment (UE-to-UE) interference and Transmission Reception Point to Transmission Reception Point (TRP-to-TRP) interference, according to some embodiments.

FIG. 2 illustrates network coordination procedures for Crosslink Interference Reference Signal (CLI-RS) configuration refinement, according to some embodiments.

FIG. 3 illustrates an example of CSI-RS refinement, according to some embodiments.

FIG. 4 illustrate network coordination procedures for victim side mitigation, according to some embodiments.

FIG. 5 illustrates network coordination procedures for aggressor side mitigation, according to some embodiments.

FIG. 6 illustrates an example of prioritizing CLI mitigation requests based on measurement reports, according to some embodiments.

FIG. 7 illustrates an example system architecture, according to some embodiments.

FIG. 8 illustrates another example system architecture, according to some embodiments.

FIG. 9 illustrates another example system architecture, according to some embodiments.

FIG. 10 illustrates a block diagram of an exemplary infrastructure equipment, according to some embodiments.

FIG. 11 illustrates a block diagram of an exemplary platform, according to some embodiments.

FIG. 12 illustrates a block diagram of baseband circuitry and front end modules, according to some embodiments.

FIG. 13 illustrates a block diagram of exemplary protocol functions that may be implemented in a wireless communication device, according to some embodiments.

FIG. 14 illustrates a block diagram of an exemplary computer system that can be utilized to implement various embodiments.

FIG. 15 illustrates a flowchart illustrating a process for a UE identifying an aggressor beam of an aggressor UE, according to some embodiments.

FIG. 16 illustrates a flowchart illustrating a process for a UE performing CLI mitigation for a victim UE, according to some embodiments.

FIG. 17 illustrates a flowchart illustrating a process for a UE performing CLI mitigation for an aggressor UE, according to some embodiments.

The features and advantages of the embodiments will become more apparent from the detailed description set forth below when taken in conjunction with the drawings, in which like reference characters identify corresponding elements throughout. In the drawings, like reference numbers generally indicate identical, functionally similar, and/or structurally similar elements. The drawing in which an element first appears is indicated by the leftmost digit(s) in the corresponding reference number.

DETAILED DESCRIPTION

The following detailed description refers to the accompanying drawings. The same reference numbers may be used in different drawings to identify the same or similar elements. In the following description, for purposes of explanation and not limitation, specific details are set forth such as particular structures, architectures, interfaces, techniques, etc. in order to provide a thorough understanding of the various aspects of various embodiments. However, it will be apparent to those skilled in the art having the benefit of the present disclosure that the various aspects of the various embodiments may be practiced in other examples that depart from these specific details. In certain instances, descriptions of well-known devices, circuits, and methods are omitted so as not to obscure the description of the various embodiments with unnecessary detail. For the purposes of the present document, the phrase “A or B” means (A), (B), or (A and B).

New radio (NR) can support duplexing flexibility in both paired and unpaired spectrum (e.g., 3GPP TR38.802, “Study on New Radio Access Technology: Physical Layer Aspects,” Release 14, 2017). Two types of crosslink interference (CLI) can arise under dynamic uplink/downlink (UL/DL) operation: user element (UE) to UE interference and Transmission Reception Point (TRP) to TRP interference, as illustrated in the example in FIG. 1. FIG. 1 illustrates an example of UE-to-UE interference and TRP-to-TRP interference, according to some embodiments.

To enable CLI mitigation schemes, network coordination can be required. Next Generation NodeBs (gNBs) can coordinate/exchange information on victim and aggressor devices. The information can include the following:

- UE’s measurement reports
- Identified aggressor and/or victim UEs
- Identified aggressor and/or victim beams

As would be appreciated by a person of ordinary skill in the art, a victim device can be a UE or gNB, and an aggressor device can be a UE or gNB. As would be appreciated by a person of ordinary skill in the art, the functions and processes performed by a UE can be performed by a gNB within the UE.

gNBs can also coordinate/exchange information on data transmission, which can include the following:

- DL/UL configurations
- Transmit and receive beams
- Power control parameters
- Resource allocation and scheduling decisions

In some embodiments, network coordination messages and procedures enable CLI mitigation and improve the overall system performance of a flexible duplexing system.

In some embodiments, new network coordination messages and procedures are used for CLI mitigation. Some embodiments involve a procedure for gNBs to negotiate Crosslink Interference-Reference Signal (CLI-RS) transmission resource configurations. Some embodiments involve a procedure for gNBs to coordinate on data transmission to better manage CLI.

1. Network Coordination for CLI-RS Configuration Refinement

In some embodiments, based on UEs’ CLI measurement reports, a gNB can identify a victim UE and its aggressor UE. It can request aggressor UE’s gNB to refine the CLI-RS configuration so that it can also identify the aggressor beam of the aggressor UE. This overall procedure is illustrated in FIG. 2, according to some embodiments. FIG. 2 illustrates network coordination procedures for CLI-RS configuration refinement, according to some embodiments.

FIG. 2 illustrates a victim UE 201, a gNB 203, and an aggressor gNB 205 (also referred to as aggressor UE 205), which perform the following steps:

- Step 1: gNB 203 configures victim UE 201 on CLI measurement and reporting, as shown at 202;
- Step 2: Victim UE 201 reports CLI measurement to gNB 203, as shown at 204;
- Step 3: Based on victim UE 201’s reports, gNB 203 identifies the aggressor gNB 205, as shown at 206;
- Step 4: gNB 203 sends a CLI-RS refinement request message to aggressor gNB 205, as shown at 208;
- Step 5: Aggressor gNB 205 sends a response back to gNB 203. It can either accept or deny the CLI-RS refinement request, as shown at 210;
- Step 6: gNB 203 reconfigures victim UE 201 on CLI measurement, as shown at 212;
- Step 7: UE 201 reports new CLI measurement to gNB 203, as shown at 214;
- Step 8: Based on victim UE 201’s reports, gNB 203 identifies the aggressor beam, as shown at 216.

The CLI-RS refinement request message can contain the following fields:

Aggressor UE id can indicate the aggressor UE identified by gNB

In some embodiments, the CLI-RS refinement request message can be defined as follows

Information Element	Presence
List of UE ID >Aggressor UE ID	Mandatory

The CLI-RS refinement response message can contain the following fields:

- Accept or deny indication
- New CLI-RS Transmission configuration (also referred to as updated CLI-RS transmission configuration), if the request is accepted

In some embodiments, the CLI-RS refinement response message can be defined as follows

Information Element	Presence
Accept/Deny	Mandatory
List of UE CLI-RS transmission resource configuration >UE ID >UE CLI-RS transmission resource configuration	Optional

5

FIG. 3 illustrates an example of how a CLI-RS refinement request message can be used in a network, according to some embodiments.

2. Network Coordination for CLI Victim-Side Mitigation

In some embodiments, based on UEs' CLI measurement reports, a gNB can identify a victim UE and its aggressor UE gNB. It can request transmission information from aggressor UE's gNB to enable victim-side mitigation. The overall procedure is illustrated in FIG. 4, according to some embodiments. FIG. 4 illustrates network coordination procedures for victim side mitigation, according to some embodiments.

FIG. 4 illustrates a victim UE 401, a gNB 403 and an aggressor gNB 405 (also referred to as aggressor UE 405), which perform the following steps:

- Step 1: gNB 403 configures victim UE 401 on CLI measurement and reporting, as shown at 402;
- Step 2: Victim UE 401 reports CLI measurement to gNB 403, as shown at 404;
- Step 3: Based on victim UE 401's reports, gNB 403 identifies the aggressor gNB 405, as shown at 406;
- Step 4: gNB 403 sends a transmission information exchange request message to aggressor gNB 405, as shown at 408;
- Step 5: Aggressor gNB 405 sends a response back to gNB 403. It can either accept or deny the request. If it accepts the request, then it send the transmission information to gNB 403, as shown at 410;
- Step 6: gNB 403 applies victim-side mitigation schemes to victim UE 401, as shown at 412.

The transmission information request message can contain the following fields:

- Aggressor UE id: indicates the aggressor UE identified by gNB
- Transmission information type which can indicate the type of transmission information gNB needs for CLI mitigation. Possible types can include, but are not limited to:
 - DL/UL configuration
 - Power control parameters
 - Resource allocation and scheduling decision
 - Transmission (Tx) beam information
 - Time duration which can indicate the time duration of interested transmission information

In some embodiments, the transmission information request message can be defined as follows

Information Element	Presence
List of transmission information request	Mandatory
>Aggressor UE ID	Mandatory
>Transmission information type	Mandatory
>Time duration	Optional

The transmission information response message can contain the following fields:

- Accept or deny indication
- Transmission information if the request is accepted. Possible transmission information can include:
 - DL/UL configuration
 - Power control parameters
 - Resource allocation and scheduling decision
 - Tx beam information
 - Time duration: indicates the time duration of interested transmission information

6

In some embodiment, the transmission information response message can be defined as follows

Information Element	Presence
Accept/Deny	Mandatory
List of DL/UL configuration	Optional
>Cell ID	
>DL/UL configuration	
>List of Dedicated DL/UL configuration	
>>UE ID	
>>UE specific DL/UL configuration	
List of UL transmission information	Optional
>UE ID	
>Cell ID	
>BWP ID	
>UL/SUL indication	
>Power control parameters	
>TX beam indication	
>Scheduling decision	
>Resource allocation decision	

In some embodiments, based on the exchanged transmission information, a gNB has the following options for CLI mitigation

- Based on exchanged DL/UL configurations, a gNB can schedule a victim UE for DL transmission only when it is a DL slot for all neighboring cells.
- Based on exchanged transmit beam information, a gNB can advise a victim UE on which receive beam(s) to use for DL reception, via TCI-states
- Based on exchanged power control parameters, a gNB can increase the DL transmit power for a victim UE.
- Based on exchanged resource allocation and scheduling decisions, a gNB can avoid scheduling a victim UE on the same time-frequency resource as its aggressor UE.

3. Network Coordination for CLI Aggressor-Side Mitigation

FIG. 5 illustrates network coordination procedures for aggressor side mitigation, according to some embodiments. FIG. 5 illustrates a victim UE 501, a gNB 503 and an aggressor gNB 505 (also referred to as aggressor UE 505), which perform the following steps:

- Step 1: gNB 503 configures victim UE 501 on CLI measurement and reporting, as shown at 502;
- Step 2: Victim UE 501 reports CLI measurement to gNB 503, as shown at 504;
- Step 3: Based on victim UE 501's reports, gNB 503 identifies the aggressor gNB 505, as shown at 506;
- Step 4: gNB 503 sends a CLI mitigation request message to aggressor gNB 505, as shown at 508;
- Step 5: Aggressor gNB 505 sends a response back to gNB 503. It can either accept or deny the CLI mitigation request, as shown at 510.

The CLI mitigation request message can contain the following fields:

- Aggressor UE id which can indicate the aggressor UE identified by gNB
- Transmission information which can indicate the information that can be used for aggressor side CLI mitigation. Possible transmission information can include:
 - DL/UL configuration
 - Power control parameters
 - Resource allocation and scheduling decision
 - Tx beam information (e.g., see 502 of FIG. 5)
 - CLI-measurement reports: gNB can forward its UEs' measurement reports to the aggressor's gNB
 - Time duration which can indicate the time duration of interested transmission information

In some embodiments, the CLI mitigation response message can be defined as follows

Information Element	Presence
List of victim UE information	Mandatory
>UE ID	Mandatory
>Aggressor UE ID/beam index	Mandatory
>UE CLI measurement reports	Optional
List of DL/UL configuration	Optional
>Cell ID	
>DL/UL configuration	
>List of Dedicated DL/UL configuration	
>>UE ID	
>>UE specific DL/UL configuration	
List of UL transmission information	Optional
>UE ID	
>Cell ID	
>BWP ID	
>Power control parameters	
>Scheduling decision	
>Resource allocation decision	

The CLI mitigation response message can contain the following fields:

Accept or deny indication (e.g., see 504 of FIG. 5).

In some embodiments, the CLI mitigation response message can be defined as follows

Information Element	Presence
Accept/Deny	Mandatory

In some embodiments, if the CLI mitigation request is accepted, an aggressor's gNB can have the following options for CLI mitigation

Based on exchanged DL/UL configurations, a gNB can schedule the aggressor UE for UL transmission only when it is also a UL slot in the victim's cells.

Based on exchanged transmit beam information, a gNB can advise the aggressor UE on which transmit beam(s) to use for UL transmission, via RRC spatialRelation-Info or L1 SRI

Based on exchanged power control parameters, a gNB can decrease the aggressor UE's UL transmit power, via power control commands.

Based on exchanged resource allocation and scheduling decisions, a gNB can avoid scheduling the aggressor UE on the same time-frequency resource as its victim.

In some embodiments, the measurement reports in the CLI mitigation request can be used at the aggressor's gNB to prioritize the responses to multiple requests. FIG. 6 illustrates an example of prioritizing the CLI mitigation requests based on measurement reports.

As shown in FIG. 6, gNB2 can receive two CLI mitigation request from gNB1 and gNB3 . . . gNB1 may want to avoid scheduling UE2 with beam1 and it reports the CLI-RSSI measurement as 20 dBm. On the other hand, gNB3 may want to avoid scheduling UE2 with beam2 and it reports the CLI-RSSI measurement as 15 dBm. gNB2 can prioritize the CLI mitigation response based on the CLI measurement value. In FIG. 6, since gNB1's CLI measurement report shows higher interference level on beam1, gNB2 can accept gNB1's request and deny gNB3's request.

4. Network Coordination Interface

In some embodiments, the network coordination procedures and messages can be performed over X2, Xn, or F1 interface.

Systems and Implementations

FIG. 7 illustrates an example architecture of a system 700 of a network, in accordance with various embodiments. The following description is provided for an example system 700 that operates in conjunction with the LTE system standards and 5G or NR system standards as provided by 3GPP technical specifications. However, the example embodiments are not limited in this regard and the described embodiments may apply to other networks that benefit from the principles described herein, such as future 3GPP systems (e.g., Sixth Generation (6G)) systems, IEEE 802.16 protocols (e.g., WMAN, WiMAX, etc.), or the like.

As shown by FIG. 7, the system 700 includes UE 701a and UE 701b (collectively referred to as "UEs 701" or "UE 701"). In this example, UEs 701 are illustrated as smartphones (e.g., handheld touchscreen mobile computing devices connectable to one or more cellular networks), but may also comprise any mobile or non-mobile computing device, such as consumer electronics devices, cellular phones, smartphones, feature phones, tablet computers, wearable computer devices, personal digital assistants (PDAs), pagers, wireless handsets, desktop computers, laptop computers, in-vehicle infotainment (IVI), in-car entertainment (ICE) devices, an Instrument Cluster (IC), head-up display (HUD) devices, onboard diagnostic (OBD) devices, dashtop mobile equipment (DME), mobile data terminals (MDTs), Electronic Engine Management System (EEMS), electronic/engine control units (ECUs), electronic/engine control modules (ECMs), embedded systems, microcontrollers, control modules, engine management systems (EMS), networked or "smart" appliances, MTC devices, M2M, IoT devices, and/or the like.

In some embodiments, any of the UEs 701 may be IoT UEs, which may comprise a network access layer designed for low-power IoT applications utilizing short-lived UE connections. An IoT UE can utilize technologies such as M2M or MTC for exchanging data with an MTC server or device via a PLMN, ProSe or D2D communication, sensor networks, or IoT networks. The M2M or MTC exchange of data may be a machine-initiated exchange of data. An IoT network describes interconnecting IoT UEs, which may include uniquely identifiable embedded computing devices (within the Internet infrastructure), with short-lived connections. The IoT UEs may execute background applications (e.g., keep-alive messages, status updates, etc.) to facilitate the connections of the IoT network.

The UEs 701 may be configured to connect, for example, communicatively couple, with an or RAN 710. In embodiments, the RAN 710 may be an NG RAN or a 5G RAN, an E-UTRAN, or a legacy RAN, such as a UTRAN or GERAN. As used herein, the term "NG RAN" or the like may refer to a RAN 710 that operates in an NR or 5G system 700, and the term "E-UTRAN" or the like may refer to a RAN 710 that operates in an LTE or 4G system 700. The UEs 701 utilize connections (or channels) 703 and 704, respectively, each of which comprises a physical communications interface or layer (discussed in further detail below).

In this example, the connections 703 and 704 are illustrated as an air interface to enable communicative coupling, and can be consistent with cellular communications protocols, such as a GSM protocol, a CDMA network protocol, a PTT protocol, a POC protocol, a UMTS protocol, a 3GPP LTE protocol, a 5G protocol, a NR protocol, and/or any of the other communications protocols discussed herein. In embodiments, the UEs 701 may directly exchange communication data via a ProSe interface 705. The ProSe interface 705 may alternatively be referred to as a SL interface 705

and may comprise one or more logical channels, including but not limited to a PSCCH, a PSSCH, a PSDCH, and a PSBCH.

The UE **701b** is shown to be configured to access an AP **706** (also referred to as “WLAN node **706**,” “WLAN **706**,” “WLAN Termination **706**,” “WT **706**” or the like) via connection **707**. The connection **707** can comprise a local wireless connection, such as a connection consistent with any IEEE 802.11 protocol, wherein the AP **706** would comprise a wireless fidelity (Wi-Fi®) router. In this example, the AP **706** is shown to be connected to the Internet without connecting to the core network of the wireless system (described in further detail below). In various embodiments, the UE **701b**, RAN **710**, and AP **706** may be configured to utilize LWA operation and/or LWIP operation. The LWA operation may involve the UE **701b** in RRC_CONNECTED being configured by a RAN node **711a-b** to utilize radio resources of LTE and WLAN. LWIP operation may involve the UE **701b** using WLAN radio resources (e.g., connection **707**) via IPsec protocol tunneling to authenticate and encrypt packets (e.g., IP packets) sent over the connection **707**. IPsec tunneling may include encapsulating the entirety of original IP packets and adding a new packet header, thereby protecting the original header of the IP packets.

The RAN **710** can include one or more AN nodes or RAN nodes **711a** and **711b** (collectively referred to as “RAN nodes **711**” or “RAN node **711**”) that enable the connections **703** and **704**. As used herein, the terms “access node,” “access point,” or the like may describe equipment that provides the radio baseband functions for data and/or voice connectivity between a network and one or more users. These access nodes can be referred to as BS, gNBs, RAN nodes, eNBs, NodeBs, RSUs, TRxPs or TRPs, and so forth, and can comprise ground stations (e.g., terrestrial access points) or satellite stations providing coverage within a geographic area (e.g., a cell). As used herein, the term “NG RAN node” or the like may refer to a RAN node **711** that operates in an NR or 5G system **700** (for example, a gNB), and the term “E-UTRAN node” or the like may refer to a RAN node **711** that operates in an LTE or 4G system **700** (e.g., an eNB). According to various embodiments, the RAN nodes **711** may be implemented as one or more of a dedicated physical device such as a macrocell base station, and/or a low power (LP) base station for providing femto-cells, picocells or other like cells having smaller coverage areas, smaller user capacity, or higher bandwidth compared to macrocells.

In some embodiments, all or parts of the RAN nodes **711** may be implemented as one or more software entities running on server computers as part of a virtual network, which may be referred to as a CRAN and/or a virtual baseband unit pool (vBBUP). In these embodiments, the CRAN or vBBUP may implement a RAN function split, such as a PDCP split wherein RRC and PDCP layers are operated by the CRAN/vBBUP and other L2 protocol entities are operated by individual RAN nodes **711**; a MAC/PHY split wherein RRC, PDCP, RLC, and MAC layers are operated by the CRAN/vBBUP and the PHY layer is operated by individual RAN nodes **711**; or a “lower PHY” split wherein RRC, PDCP, RLC, MAC layers and upper portions of the PHY layer are operated by the CRAN/vBBUP and lower portions of the PHY layer are operated by individual RAN nodes **711**. This virtualized framework allows the freed-up processor cores of the RAN nodes **711** to perform other virtualized applications. In some implementations, an individual RAN node **711** may represent individual gNB-

DUs that are connected to a gNB-CU via individual FI interfaces (not shown by FIG. 7). In these implementations, the gNB-DUs may include one or more remote radio heads or RFEMs (see, e.g., FIG. 10), and the gNB-CU may be operated by a server that is located in the RAN **710** (not shown) or by a server pool in a similar manner as the CRAN/vBBUP. Additionally or alternatively, one or more of the RAN nodes **711** may be next generation eNBs (ng-eNBs), which are RAN nodes that provide E-UTRA user plane and control plane protocol terminations toward the UEs **701**, and are connected to a 5GC (e.g., CN **920** of FIG. 9) via an NG interface (discussed infra).

In V2X scenarios one or more of the RAN nodes **711** may be or act as RSUs. The term “Road Side Unit” or “RSU” may refer to any transportation infrastructure entity used for V2X communications. An RSU may be implemented in or by a suitable RAN node or a stationary (or relatively stationary) UE, where an RSU implemented in or by a UE may be referred to as a “UE-type RSU,” an RSU implemented in or by an eNB may be referred to as an “eNB-type RSU,” an RSU implemented in or by a gNB may be referred to as a “gNB-type RSU,” and the like. In one example, an RSU is a computing device coupled with radio frequency circuitry located on a roadside that provides connectivity support to passing vehicle UEs **701** (vUEs **701**). The RSU may also include internal data storage circuitry to store intersection map geometry, traffic statistics, media, as well as applications/software to sense and control ongoing vehicular and pedestrian traffic. The RSU may operate on the 5.9 GHz Direct Short Range Communications (DSRC) band to provide very low latency communications required for high speed events, such as crash avoidance, traffic warnings, and the like. Additionally or alternatively, the RSU may operate on the cellular V2X band to provide the aforementioned low latency communications, as well as other cellular communications services. Additionally or alternatively, the RSU may operate as a Wi-Fi hotspot (2.4 GHz band) and/or provide connectivity to one or more cellular networks to provide uplink and downlink communications. The computing device(s) and some or all of the radiofrequency circuitry of the RSU may be packaged in a weatherproof enclosure suitable for outdoor installation, and may include a network interface controller to provide a wired connection (e.g., Ethernet) to a traffic signal controller and/or a backhaul network.

Any of the RAN nodes **711** can terminate the air interface protocol and can be the first point of contact for the UEs **701**. In some embodiments, any of the RAN nodes **711** can fulfill various logical functions for the RAN **710** including, but not limited to, radio network controller (RNC) functions such as radio bearer management, uplink and downlink dynamic radio resource management and data packet scheduling, and mobility management.

In embodiments, the UEs **701** can be configured to communicate using OFDM communication signals with each other or with any of the RAN nodes **711** over a multicarrier communication channel in accordance with various communication techniques, such as, but not limited to, an OFDMA communication technique (e.g., for downlink communications) or a SC-FDMA communication technique (e.g., for uplink and ProSe or sidelink communications), although the scope of the embodiments is not limited in this respect. The OFDM signals can comprise a plurality of orthogonal subcarriers.

In some embodiments, a downlink resource grid can be used for downlink transmissions from any of the RAN nodes **711** to the UEs **701**, while uplink transmissions can utilize

similar techniques. The grid can be a time-frequency grid, called a resource grid or time-frequency resource grid, which is the physical resource in the downlink in each slot. Such a time-frequency plane representation is a common practice for OFDM systems, which makes it intuitive for radio resource allocation. Each column and each row of the resource grid corresponds to one OFDM symbol and one OFDM subcarrier, respectively. The duration of the resource grid in the time domain corresponds to one slot in a radio frame. The smallest time-frequency unit in a resource grid is denoted as a resource element. Each resource grid comprises a number of resource blocks, which describe the mapping of certain physical channels to resource elements. Each resource block comprises a collection of resource elements; in the frequency domain, this may represent the smallest quantity of resources that currently can be allocated. There are several different physical downlink channels that are conveyed using such resource blocks.

According to various embodiments, the UEs **701**, **702** and the RAN nodes **711**, **712** communicate data (for example, transmit and receive) data over a licensed medium (also referred to as the “licensed spectrum” and/or the “licensed band”) and an unlicensed shared medium (also referred to as the “unlicensed spectrum” and/or the “unlicensed band”). The licensed spectrum may include channels that operate in the frequency range of approximately 400 MHz to approximately 3.8 GHz, whereas the unlicensed spectrum may include the 5 GHz band.

To operate in the unlicensed spectrum, the UEs **701**, **702** and the RAN nodes **711**, **712** may operate using LAA, eLAA, and/or feLAA mechanisms. In these implementations, the UEs **701**, **702** and the RAN nodes **711**, **712** may perform one or more known medium-sensing operations and/or carrier-sensing operations in order to determine whether one or more channels in the unlicensed spectrum is unavailable or otherwise occupied prior to transmitting in the unlicensed spectrum. The medium/carrier sensing operations may be performed according to a listen-before-talk (LBT) protocol.

LBT is a mechanism whereby equipment (for example, UEs **701**, **702**, RAN nodes **711**, **712**, etc.) senses a medium (for example, a channel or carrier frequency) and transmits when the medium is sensed to be idle (or when a specific channel in the medium is sensed to be unoccupied). The medium sensing operation may include CCA, which utilizes at least ED to determine the presence or absence of other signals on a channel in order to determine if a channel is occupied or clear. This LBT mechanism allows cellular/LAA networks to coexist with incumbent systems in the unlicensed spectrum and with other LAA networks. ED may include sensing RF energy across an intended transmission band for a period of time and comparing the sensed RF energy to a predefined or configured threshold.

Typically, the incumbent systems in the 5 GHz band are WLANs based on IEEE 802.11 technologies. WLAN employs a contention-based channel access mechanism, called CSMA/CA. Here, when a WLAN node (e.g., a mobile station (MS) such as UE **701** or **702**, AP **706**, or the like) intends to transmit, the WLAN node may first perform CCA before transmission. Additionally, a backoff mechanism is used to avoid collisions in situations where more than one WLAN node senses the channel as idle and transmits at the same time. The backoff mechanism may be a counter that is drawn randomly within the CWS, which is increased exponentially upon the occurrence of collision and reset to a minimum value when the transmission succeeds. The LBT mechanism designed for LAA is somewhat similar to the

CSMA/CA of WLAN. In some implementations, the LBT procedure for DL or UL transmission bursts including PDSCH or PUSCH transmissions, respectively, may have an LAA contention window that is variable in length between X and Y ECCA slots, where X and Y are minimum and maximum values for the CWSs for LAA. In one example, the minimum CWS for an LAA transmission may be 9 microseconds (μ s); however, the size of the CWS and a MCOT (for example, a transmission burst) may be based on governmental regulatory requirements.

The LAA mechanisms are built upon CA technologies of LTE-Advanced systems. In CA, each aggregated carrier is referred to as a CC. A CC may have a bandwidth of 1.4, 3, 5, 10, 15 or 20 MHz and a maximum of five CCs can be aggregated, and therefore, a maximum aggregated bandwidth is 100 MHz. In FDD systems, the number of aggregated carriers can be different for DL and UL, where the number of UL CCs is equal to or lower than the number of DL component carriers. In some cases, individual CCs can have a different bandwidth than other CCs. In TDD systems, the number of CCs as well as the bandwidths of each CC is usually the same for DL and UL.

CA also comprises individual serving cells to provide individual CCs. The coverage of the serving cells may differ, for example, because CCs on different frequency bands will experience different pathloss. A primary service cell or PCell may provide a PCC for both UL and DL, and may handle RRC and NAS related activities. The other serving cells are referred to as SCells, and each SCell may provide an individual SCC for both UL and DL. The SCCs may be added and removed as required, while changing the PCC may require the UE **701**, **702** to undergo a handover. In LAA, eLAA, and feLAA, some or all of the SCells may operate in the unlicensed spectrum (referred to as “LAA SCells”), and the LAA SCells are assisted by a PCell operating in the licensed spectrum. When a UE is configured with more than one LAA SCell, the UE may receive UL grants on the configured LAA SCells indicating different PUSCH starting positions within a same subframe.

The PDSCH carries user data and higher-layer signaling to the UEs **701**. The PDCCH carries information about the transport format and resource allocations related to the PDSCH channel, among other things. It may also inform the UEs **701** about the transport format, resource allocation, and HARQ information related to the uplink shared channel. Typically, downlink scheduling (assigning control and shared channel resource blocks to the UE **701b** within a cell) may be performed at any of the RAN nodes **711** based on channel quality information fed back from any of the UEs **701**. The downlink resource assignment information may be sent on the PDCCH used for (e.g., assigned to) each of the UEs **701**.

The PDCCH uses CCEs to convey the control information. Before being mapped to resource elements, the PDCCH complex-valued symbols may first be organized into quadruplets, which may then be permuted using a sub-block interleaver for rate matching. Each PDCCH may be transmitted using one or more of these CCEs, where each CCE may correspond to nine sets of four physical resource elements known as REGs. Four Quadrature Phase Shift Keying (QPSK) symbols may be mapped to each REG. The PDCCH can be transmitted using one or more CCEs, depending on the size of the DCI and the channel condition. There can be four or more different PDCCH formats defined in LTE with different numbers of CCEs (e.g., aggregation level, L=1, 2, 4, or 8).

Some embodiments may use concepts for resource allocation for control channel information that are an extension of the above-described concepts. For example, some embodiments may utilize an EPDCCH that uses PDSCH resources for control information transmission. The EPDCCH may be transmitted using one or more ECCEs. Similar to above, each ECCE may correspond to nine sets of four physical resource elements known as an EREGs. An ECCE may have other numbers of EREGs in some situations.

The RAN nodes **711** may be configured to communicate with one another via interface **712**. In embodiments where the system **700** is an LTE system (e.g., when CN **720** is an EPC **820** as in FIG. **8**), the interface **712** may be an X2 interface **712**. The X2 interface may be defined between two or more RAN nodes **711** (e.g., two or more eNBs and the like) that connect to EPC **720**, and/or between two eNBs connecting to EPC **720**. In some implementations, the X2 interface may include an X2 user plane interface (X2-U) and an X2 control plane interface (X2-C). The X2-U may provide flow control mechanisms for user data packets transferred over the X2 interface, and may be used to communicate information about the delivery of user data between eNBs. For example, the X2-U may provide specific sequence number information for user data transferred from a MeNB to an SeNB; information about successful in sequence delivery of PDCP PDUs to a UE **701** from an SeNB for user data; information of PDCP PDUs that were not delivered to a UE **701**; information about a current minimum desired buffer size at the SeNB for transmitting to the UE user data; and the like. The X2-C may provide intra-LTE access mobility functionality, including context transfers from source to target eNBs, user plane transport control, etc.; load management functionality; as well as inter-cell interference coordination functionality.

In embodiments where the system **700** is a 5G or NR system (e.g., when CN **720** is an 5GC **920** as in FIG. **9**), the interface **712** may be an Xn interface **712**. The Xn interface is defined between two or more RAN nodes **711** (e.g., two or more gNBs and the like) that connect to 5GC **720**, between a RAN node **711** (e.g., a gNB) connecting to 5GC **720** and an eNB, and/or between two eNBs connecting to 5GC **720**. In some implementations, the Xn interface may include an Xn user plane (Xn-U) interface and an Xn control plane (Xn-C) interface. The Xn-U may provide non-guaranteed delivery of user plane PDUs and support/provide data forwarding and flow control functionality. The Xn-C may provide management and error handling functionality, functionality to manage the Xn-C interface; mobility support for UE **701** in a connected mode (e.g., CM-CONNECTED) including functionality to manage the UE mobility for connected mode between one or more RAN nodes **711**. The mobility support may include context transfer from an old (source) serving RAN node **711** to new (target) serving RAN node **711**; and control of user plane tunnels between old (source) serving RAN node **711** to new (target) serving RAN node **711**. A protocol stack of the Xn-U may include a transport network layer built on Internet Protocol (IP) transport layer, and a GTP-U layer on top of a UDP and/or IP layer(s) to carry user plane PDUs. The Xn-C protocol stack may include an application layer signaling protocol (referred to as Xn Application Protocol (Xn-AP)) and a transport network layer that is built on SCTP. The SCTP may be on top of an IP layer, and may provide the guaranteed delivery of application layer messages. In the transport IP layer, point-to-point transmission is used to deliver the signaling PDUs. In other implementations, the Xn-U protocol stack

and/or the Xn-C protocol stack may be same or similar to the user plane and/or control plane protocol stack(s) shown and described herein.

The RAN **710** is shown to be communicatively coupled to a core network-in this embodiment, core network (CN) **720**. The CN **720** may comprise a plurality of network elements **722**, which are configured to offer various data and telecommunications services to customers/subscribers (e.g., users of UEs **701**) who are connected to the CN **720** via the RAN **710**. The components of the CN **720** may be implemented in one physical node or separate physical nodes including components to read and execute instructions from a machine-readable or computer-readable medium (e.g., a non-transitory machine-readable storage medium). In some embodiments, NFV may be utilized to virtualize any or all of the above-described network node functions via executable instructions stored in one or more computer-readable storage mediums (described in further detail below). A logical instantiation of the CN **720** may be referred to as a network slice, and a logical instantiation of a portion of the CN **720** may be referred to as a network sub-slice. NFV architectures and infrastructures may be used to virtualize one or more network functions, alternatively performed by proprietary hardware, onto physical resources comprising a combination of industry-standard server hardware, storage hardware, or switches. In other words, NFV systems can be used to execute virtual or reconfigurable implementations of one or more EPC components/functions.

Generally, the application server **730** may be an element offering applications that use IP bearer resources with the core network (e.g., UMTS PS domain, LTE PS data services, etc.). The application server **730** can also be configured to support one or more communication services (e.g., VoIP sessions, PTT sessions, group communication sessions, social networking services, etc.) for the UEs **701** via the EPC **720**.

In embodiments, the CN **720** may be a 5GC (referred to as "5GC **720**" or the like), and the RAN **710** may be connected with the CN **720** via an NG interface **713**. In embodiments, the NG interface **713** may be split into two parts, an NG user plane (NG-U) interface **714**, which carries traffic data between the RAN nodes **711** and a UPF, and the S1 control plane (NG-C) interface **715**, which is a signaling interface between the RAN nodes **711** and AMFs. Embodiments where the CN **720** is a 5GC **720** are discussed in more detail with regard to FIG. **9**.

In embodiments, the CN **720** may be a 5G CN (referred to as "5G CN **720**" or the like), while in other embodiments, the CN **720** may be an EPC. Where CN **720** is an EPC (referred to as "EPC **720**" or the like), the RAN **710** may be connected with the CN **720** via an S1 interface **713**. In embodiments, the S1 interface **713** may be split into two parts, an S1 user plane (S1-U) interface **714**, which carries traffic data between the RAN nodes **711** and the S-GW, and the S1-MME interface **715**, which is a signaling interface between the RAN nodes **711** and MMEs. An example architecture wherein the CN **720** is an EPC **720** is shown by FIG. **8**.

FIG. **8** illustrates an example architecture of a system **800** including a first CN **820**, in accordance with various embodiments. In this example, system **800** may implement the LTE standard wherein the CN **820** is an EPC **820** that corresponds with CN **720** of FIG. **7**. Additionally, the UE **801** may be the same or similar as the UEs **701** of FIG. **7**, and the E-UTRAN **810** may be a RAN that is the same or similar to the RAN **710** of FIG. **7**, and which may include

RAN nodes 711 discussed previously. The CN 820 may comprise MMEs 821, an S-GW 822, a P-GW 823, a HSS 824, and a SGSN 825.

The MMEs 821 may be similar in function to the control plane of legacy SGSN, and may implement MM functions to keep track of the current location of a UE 801. The MMEs 821 may perform various MM procedures to manage mobility aspects in access such as gateway selection and tracking area list management. MM (also referred to as "EPS MM" or "EMM" in E-UTRAN systems) may refer to all applicable procedures, methods, data storage, etc. that are used to maintain knowledge about a present location of the UE 801, provide user identity confidentiality, and/or perform other like services to users/subscribers. Each UE 801 and the MME 821 may include an MM or EMM sublayer, and an MM context may be established in the UE 801 and the MME 821 when an attach procedure is successfully completed. The MM context may be a data structure or database object that stores MM-related information of the UE 801. The MMEs 821 may be coupled with the HSS 824 via an S6a reference point, coupled with the SGSN 825 via an S3 reference point, and coupled with the S-GW 822 via an S11 reference point.

The SGSN 825 may be a node that serves the UE 801 by tracking the location of an individual UE 801 and performing security functions. In addition, the SGSN 825 may perform Inter-EPC node signaling for mobility between 2G/3G and E-UTRAN 3GPP access networks; PDN and S-GW selection as specified by the MMEs 821; handling of UE 801 time zone functions as specified by the MMEs 821; and MME selection for handovers to E-UTRAN 3GPP access network. The S3 reference point between the MMEs 821 and the SGSN 825 may enable user and bearer information exchange for inter-3GPP access network mobility in idle and/or active states.

The HSS 824 may comprise a database for network users, including subscription-related information to support the network entities' handling of communication sessions. The EPC 820 may comprise one or several HSSs 824, depending on the number of mobile subscribers, on the capacity of the equipment, on the organization of the network, etc. For example, the HSS 824 can provide support for routing/roaming, authentication, authorization, naming/addressing resolution, location dependencies, etc. An S6a reference point between the HSS 824 and the MMEs 821 may enable transfer of subscription and authentication data for authenticating/authorizing user access to the EPC 820 between HSS 824 and the MMEs 821.

The S-GW 822 may terminate the S1 interface 713 ("S1-U" in FIG. 8) toward the RAN 810, and routes data packets between the RAN 810 and the EPC 820. In addition, the S-GW 822 may be a local mobility anchor point for inter-RAN node handovers and also may provide an anchor for inter-3GPP mobility. Other responsibilities may include lawful intercept, charging, and some policy enforcement. The S11 reference point between the S-GW 822 and the MMEs 821 may provide a control plane between the MMEs 821 and the S-GW 822. The S-GW 822 may be coupled with the P-GW 823 via an S5 reference point.

The P-GW 823 may terminate an SGi interface toward a PDN 830. The P-GW 823 may route data packets between the EPC 820 and external networks such as a network including the application server 730 (alternatively referred to as an "AF") via an IP interface 725 (see e.g., FIG. 7). In embodiments, the P-GW 823 may be communicatively coupled to an application server (application server 730 of FIG. 7 or PDN 830 in FIG. 8) via an IP communications

interface 725 (see, e.g., FIG. 7). The S5 reference point between the P-GW 823 and the S-GW 822 may provide user plane tunneling and tunnel management between the P-GW 823 and the S-GW 822. The S5 reference point may also be used for S-GW 822 relocation due to UE 801 mobility and if the S-GW 822 needs to connect to a non-located P-GW 823 for the required PDN connectivity. The P-GW 823 may further include a node for policy enforcement and charging data collection (e.g., PCEF (not shown)). Additionally, the SGi reference point between the P-GW 823 and the packet data network (PDN) 830 may be an operator external public, a private PDN, or an intra operator packet data network, for example, for provision of IMS services. The P-GW 823 may be coupled with a PCRF 826 via a Gx reference point.

PCRF 826 is the policy and charging control element of the EPC 820. In a non-roaming scenario, there may be a single PCRF 826 in the Home Public Land Mobile Network (HPLMN) associated with a UE 801's Internet Protocol Connectivity Access Network (IP-CAN) session. In a roaming scenario with local breakout of traffic, there may be two PCRFs associated with a UE 801's IP-CAN session, a Home PCRF (H-PCRF) within an HPLMN and a Visited PCRF (V-PCRF) within a Visited Public Land Mobile Network (VPLMN). The PCRF 826 may be communicatively coupled to the application server 830 via the P-GW 823. The application server 830 may signal the PCRF 826 to indicate a new service flow and select the appropriate QoS and charging parameters. The PCRF 826 may provision this rule into a PCEF (not shown) with the appropriate TFT and QCI, which commences the QoS and charging as specified by the application server 830. The Gx reference point between the PCRF 826 and the P-GW 823 may allow for the transfer of QoS policy and charging rules from the PCRF 826 to PCEF in the P-GW 823. An Rx reference point may reside between the PDN 830 (or "AF 830") and the PCRF 826.

FIG. 9 illustrates an architecture of a system 900 including a second CN 920 in accordance with various embodiments. The system 900 is shown to include a UE 901, which may be the same or similar to the UEs 701 and UE 801 discussed previously; a (R)AN 910, which may be the same or similar to the RAN 710 and RAN 810 discussed previously; and a DN 903, which may be, for example, operator services, Internet access or 3rd party services; and a 5GC 920. The 5GC 920 may include an AUSF 922; an AMF 921; a SMF 924; a NEF 923; a PCF 926; a NRF 925; a UDM 927; an AF 928; a UPF 902; and a NSSF 929.

The UPF 902 may act as an anchor point for intra-RAT and inter-RAT mobility, an external PDU session point of interconnect to DN 903, and a branching point to support multi-homed PDU session. The UPF 902 may also perform packet routing and forwarding, perform packet inspection, enforce the user plane part of policy rules, lawfully intercept packets (UP collection), perform traffic usage reporting, perform QoS handling for a user plane (e.g., packet filtering, gating, UL/DL rate enforcement), perform Uplink Traffic verification (e.g., SDF to QoS flow mapping), transport level packet marking in the uplink and downlink, and perform downlink packet buffering and downlink data notification triggering. UPF 902 may include an uplink classifier to support routing traffic flows to a data network. The DN 903 may represent various network operator services, Internet access, or third party services. DN 903 may include, or be similar to, application server 730 discussed previously. The UPF 902 may interact with the SMF 924 via an N4 reference point between the SMF 924 and the UPF 902.

The AUSF 922 may store data for authentication of UE 901 and handle authentication-related functionality. The AUSF 922 may facilitate a common authentication framework for various access types. The AUSF 922 may communicate with the AMF 921 via an N12 reference point between the AMF 921 and the AUSF 922; and may communicate with the UDM 927 via an N13 reference point between the UDM 927 and the AUSF 922. Additionally, the AUSF 922 may exhibit an Nausf service-based interface.

The AMF 921 may be responsible for registration management (e.g., for registering UE 901, etc.), connection management, reachability management, mobility management, and lawful interception of AMF-related events, and access authentication and authorization. The AMF 921 may be a termination point for the an N11 reference point between the AMF 921 and the SMF 924. The AMF 921 may provide transport for SM messages between the UE 901 and the SMF 924, and act as a transparent proxy for routing SM messages. AMF 921 may also provide transport for SMS messages between UE 901 and an SMSF (not shown by FIG. 9). AMF 921 may act as SEAF, which may include interaction with the AUSF 922 and the UE 901, receipt of an intermediate key that was established as a result of the UE 901 authentication process. Where USIM based authentication is used, the AMF 921 may retrieve the security material from the AUSF 922. AMF 921 may also include a SCM function, which receives a key from the SEA that it uses to derive access-network specific keys. Furthermore, AMF 921 may be a termination point of a RAN CP interface, which may include or be an N2 reference point between the (R)AN 910 and the AMF 921; and the AMF 921 may be a termination point of NAS (N1) signalling, and perform NAS ciphering and integrity protection.

AMF 921 may also support NAS signalling with a UE 901 over an N3 IWF interface. The N3IWF may be used to provide access to untrusted entities. N3IWF may be a termination point for the N2 interface between the (R)AN 910 and the AMF 921 for the control plane, and may be a termination point for the N3 reference point between the (R)AN 910 and the UPF 902 for the user plane. As such, the AMF 921 may handle N2 signalling from the SMF 924 and the AMF 921 for PDU sessions and QoS, encapsulate/de-encapsulate packets for IPsec and N3 tunnelling, mark N3 user-plane packets in the uplink, and enforce QoS corresponding to N3 packet marking taking into account QoS requirements associated with such marking received over N2. N3IWF may also relay uplink and downlink control-plane NAS signalling between the UE 901 and AMF 921 via an N1 reference point between the UE 901 and the AMF 921, and relay uplink and downlink user-plane packets between the UE 901 and UPF 902. The N3IWF also provides mechanisms for IPsec tunnel establishment with the UE 901. The AMF 921 may exhibit an Namf service-based interface, and may be a termination point for an N14 reference point between two AMFs 921 and an N17 reference point between the AMF 921 and a 5G-EIR (not shown by FIG. 9).

The UE 901 may need to register with the AMF 921 in order to receive network services. RM is used to register or deregister the UE 901 with the network (e.g., AMF 921), and establish a UE context in the network (e.g., AMF 921). The UE 901 may operate in an RM-REGISTERED state or an RM-DEREGISTERED state. In the RM-DEREGISTERED state, the UE 901 is not registered with the network, and the UE context in AMF 921 holds no valid location or routing information for the UE 901 so the UE 901 is not reachable by the AMF 921. In the RM-REGISTERED state, the UE

901 is registered with the network, and the UE context in AMF 921 may hold a valid location or routing information for the UE 901 so the UE 901 is reachable by the AMF 921. In the RM-REGISTERED state, the UE 901 may perform mobility Registration Update procedures, perform periodic Registration Update procedures triggered by expiration of the periodic update timer (e.g., to notify the network that the UE 901 is still active), and perform a Registration Update procedure to update UE capability information or to renegotiate protocol parameters with the network, among others.

The AMF 921 may store one or more RM contexts for the UE 901, where each RM context is associated with a specific access to the network. The RM context may be a data structure, database object, etc. that indicates or stores, inter alia, a registration state per access type and the periodic update timer. The AMF 921 may also store a 5GC MM context that may be the same or similar to the (E)MM context discussed previously. In various embodiments, the AMF 921 may store a CE mode B Restriction parameter of the UE 901 in an associated MM context or RM context. The AMF 921 may also derive the value, when needed, from the UE's usage setting parameter already stored in the UE context (and/or MM/RM context).

CM may be used to establish and release a signaling connection between the UE 901 and the AMF 921 over the N1 interface. The signaling connection is used to enable NAS signaling exchange between the UE 901 and the CN 920, and comprises both the signaling connection between the UE and the AN (e.g., RRC connection or UE-N3IWF connection for non-3GPP access) and the N2 connection for the UE 901 between the AN (e.g., RAN 910) and the AMF 921. The UE 901 may operate in one of two CM states, CM-IDLE mode or CM-CONNECTED mode. When the UE 901 is operating in the CM-IDLE state/mode, the UE 901 may have no NAS signaling connection established with the AMF 921 over the N1 interface, and there may be (R)AN 910 signaling connection (e.g., N2 and/or N3 connections) for the UE 901. When the UE 901 is operating in the CM-CONNECTED state/mode, the UE 901 may have an established NAS signaling connection with the AMF 921 over the N1 interface, and there may be a (R)AN 910 signaling connection (e.g., N2 and/or N3 connections) for the UE 901. Establishment of an N2 connection between the (R)AN 910 and the AMF 921 may cause the UE 901 to transition from CM-IDLE mode to CM-CONNECTED mode, and the UE 901 may transition from the CM-CONNECTED mode to the CM-IDLE mode when N2 signaling between the (R)AN 910 and the AMF 921 is released.

The SMF 924 may be responsible for SM (e.g., session establishment, modify and release, including tunnel maintain between UPF and AN node); UE IP address allocation and management (including optional authorization); selection and control of UP function; configuring traffic steering at UPF to route traffic to proper destination; termination of interfaces toward policy control functions; controlling part of policy enforcement and QoS; lawful intercept (for SM events and interface to LI system); termination of SM parts of NAS messages; downlink data notification; initiating AN specific SM information, sent via AMF over N2 to AN; and determining SSC mode of a session. SM may refer to management of a PDU session, and a PDU session or "session" may refer to a PDU connectivity service that provides or enables the exchange of PDUs between a UE 901 and a data network (DN) 903 identified by a Data Network Name (DNN). PDU sessions may be established upon UE 901 request, modified upon UE 901 and 5GC 920

request, and released upon UE 901 and 5GC 920 request using NAS SM signaling exchanged over the N1 reference point between the UE 901 and the SMF 924. Upon request from an application server, the 5GC 920 may trigger a specific application in the UE 901. In response to receipt of the trigger message, the UE 901 may pass the trigger message (or relevant parts/information of the trigger message) to one or more identified applications in the UE 901. The identified application(s) in the UE 901 may establish a PDU session to a specific DNN. The SMF 924 may check whether the UE 901 requests are compliant with user subscription information associated with the UE 901. In this regard, the SMF 924 may retrieve and/or request to receive update notifications on SMF 924 level subscription data from the UDM 927.

The SMF 924 may include the following roaming functionality: handling local enforcement to apply QoS SLAs (VPLMN); charging data collection and charging interface (VPLMN); lawful intercept (in VPLMN for SM events and interface to LI system); and support for interaction with external DN for transport of signalling for PDU session authorization/authentication by external DN. An N16 reference point between two SMFs 924 may be included in the system 900, which may be between another SMF 924 in a visited network and the SMF 924 in the home network in roaming scenarios. Additionally, the SMF 924 may exhibit the Nsmf service-based interface.

The NEF 923 may provide means for securely exposing the services and capabilities provided by 3GPP network functions for third party, internal exposure/re-exposure, Application Functions (e.g., AF 928), edge computing or fog computing systems, etc. In such embodiments, the NEF 923 may authenticate, authorize, and/or throttle the AFs. NEF 923 may also translate information exchanged with the AF 928 and information exchanged with internal network functions. For example, the NEF 923 may translate between an AF-Service-Identifier and an internal 5GC information. NEF 923 may also receive information from other network functions (NFs) based on exposed capabilities of other network functions. This information may be stored at the NEF 923 as structured data, or at a data storage NF using standardized interfaces. The stored information can then be re-exposed by the NEF 923 to other NFs and AFs, and/or used for other purposes such as analytics. Additionally, the NEF 923 may exhibit an Nnef service-based interface.

The NRF 925 may support service discovery functions, receive NF discovery requests from NF instances, and provide the information of the discovered NF instances to the NF instances. NRF 925 also maintains information of available NF instances and their supported services. As used herein, the terms “instantiate,” “instantiation,” and the like may refer to the creation of an instance, and an “instance” may refer to a concrete occurrence of an object, which may occur, for example, during execution of program code. Additionally, the NRF 925 may exhibit the Nnrf service-based interface.

The PCF 926 may provide policy rules to control plane function(s) to enforce them, and may also support unified policy framework to govern network behaviour. The PCF 926 may also implement an FE to access subscription information relevant for policy decisions in a UDR of the UDM 927. The PCF 926 may communicate with the AMF 921 via an N15 reference point between the PCF 926 and the AMF 921, which may include a PCF 926 in a visited network and the AMF 921 in case of roaming scenarios. The PCF 926 may communicate with the AF 928 via an N5 reference point between the PCF 926 and the AF 928; and

with the SMF 924 via an N7 reference point between the PCF 926 and the SMF 924. The system 900 and/or CN 920 may also include an N24 reference point between the PCF 926 (in the home network) and a PCF 926 in a visited network. Additionally, the PCF 926 may exhibit an Npcf service-based interface.

The UDM 927 may handle subscription-related information to support the network entities' handling of communication sessions, and may store subscription data of UE 901. For example, subscription data may be communicated between the UDM 927 and the AMF 921 via an N8 reference point between the UDM 927 and the AMF. The UDM 927 may include two parts, an application FE and a UDR (the FE and UDR are not shown by FIG. 9). The UDR may store subscription data and policy data for the UDM 927 and the PCF 926, and/or structured data for exposure and application data (including PFDs for application detection, application request information for multiple UEs 901) for the NEF 923. The Nudr service-based interface may be exhibited by the UDR 221 to allow the UDM 927, PCF 926, and NEF 923 to access a particular set of the stored data, as well as to read, update (e.g., add, modify), delete, and subscribe to notification of relevant data changes in the UDR. The UDM may include a UDM-FE, which is in charge of processing credentials, location management, subscription management and so on. Several different front ends may serve the same user in different transactions. The UDM-FE accesses subscription information stored in the UDR and performs authentication credential processing, user identification handling, access authorization, registration/mobility management, and subscription management. The UDR may interact with the SMF 924 via an N10 reference point between the UDM 927 and the SMF 924. UDM 927 may also support SMS management, wherein an SMS-FE implements the similar application logic as discussed previously. Additionally, the UDM 927 may exhibit the Nudm service-based interface.

The AF 928 may provide application influence on traffic routing, provide access to the NCE, and interact with the policy framework for policy control. The NCE may be a mechanism that allows the 5GC 920 and AF 928 to provide information to each other via NEF 923, which may be used for edge computing implementations. In such implementations, the network operator and third party services may be hosted close to the UE 901 access point of attachment to achieve an efficient service delivery through the reduced end-to-end latency and load on the transport network. For edge computing implementations, the 5GC may select a UPF 902 close to the UE 901 and execute traffic steering from the UPF 902 to DN 903 via the N6 interface. This may be based on the UE subscription data, UE location, and information provided by the AF 928. In this way, the AF 928 may influence UPF (re)selection and traffic routing. Based on operator deployment, when AF 928 is considered to be a trusted entity, the network operator may permit AF 928 to interact directly with relevant NFs. Additionally, the AF 928 may exhibit an Naf service-based interface.

The NSSF 929 may select a set of network slice instances serving the UE 901. The NSSF 929 may also determine allowed NSSAI and the mapping to the subscribed S-NSSAIs, if needed. The NSSF 929 may also determine the AMF set to be used to serve the UE 901, or a list of candidate AMF(s) 921 based on a suitable configuration and possibly by querying the NRF 925. The selection of a set of network slice instances for the UE 901 may be triggered by the AMF 921 with which the UE 901 is registered by interacting with the NSSF 929, which may lead to a change of AMF 921. The

NSSF 929 may interact with the AMF 921 via an N22 reference point between AMF 921 and NSSF 929; and may communicate with another NSSF 929 in a visited network via an N31 reference point (not shown by FIG. 9). Additionally, the NSSF 929 may exhibit an Nnssf service-based interface.

As discussed previously, the CN 920 may include an SMSF, which may be responsible for SMS subscription checking and verification, and relaying SM messages to/from the UE 901 to/from other entities, such as an SMS-GMSC/IW MSC/SMS-router. The SMS may also interact with AMF 921 and UDM 927 for a notification procedure that the UE 901 is available for SMS transfer (e.g., set a UE not reachable flag, and notifying UDM 927 when UE 901 is available for SMS).

The CN 120 may also include other elements that are not shown by FIG. 9, such as a Data Storage system/architecture, a 5G-EIR, a SEPP, and the like. The Data Storage system may include a SDSF, an UDSF, and/or the like. Any NF may store and retrieve unstructured data into/from the UDSF (e.g., UE contexts), via N18 reference point between any NF and the UDSF (not shown by FIG. 9). Individual NFs may share a UDSF for storing their respective unstructured data or individual NFs may each have their own UDSF located at or near the individual NFs. Additionally, the UDSF may exhibit an Nudsf service-based interface (not shown by FIG. 9). The 5G-EIR may be an NF that checks the status of PEI for determining whether particular equipment/entities are blacklisted from the network; and the SEPP may be a non-transparent proxy that performs topology hiding, message filtering, and policing on inter-PLMN control plane interfaces.

Additionally, there may be many more reference points and/or service-based interfaces between the NF services in the NFs; however, these interfaces and reference points have been omitted from FIG. 9 for clarity. In one example, the CN 920 may include an Nx interface, which is an inter-CN interface between the MME (e.g., MME 821) and the AMF 921 in order to enable interworking between CN 920 and CN 820. Other example interfaces/reference points may include an N5g-EIR service-based interface exhibited by a 5G-EIR, an N27 reference point between the NRF in the visited network and the NRF in the home network; and an N31 reference point between the NSSF in the visited network and the NSSF in the home network.

FIG. 10 illustrates an example of infrastructure equipment 1000 in accordance with various embodiments. The infrastructure equipment 1000 (or "system 1000") may be implemented as a base station, radio head, RAN node such as the RAN nodes 711 and/or AP 706 shown and described previously, application server(s) 730, and/or any other element/device discussed herein. In other examples, the system 1000 could be implemented in or by a UE.

The system 1000 includes application circuitry 1005, baseband circuitry 1010, one or more radio front end modules (RFEMs) 1015, memory circuitry 1020, power management integrated circuitry (PMIC) 1025, power tee circuitry 1030, network controller circuitry 1035, network interface connector 1040, satellite positioning circuitry 1045, and user interface 1050. In some embodiments, the device 1000 may include additional elements such as, for example, memory/storage, display, camera, sensor, or input/output (I/O) interface. In other embodiments, the components described below may be included in more than one device. For example, said circuitries may be separately included in more than one device for CRAN, vBBU, or other like implementations.

Application circuitry 1005 includes circuitry such as, but not limited to one or more processors (or processor cores), cache memory, and one or more of low drop-out voltage regulators (LDOs), interrupt controllers, serial interfaces such as SPI, I²C or universal programmable serial interface module, real time clock (RTC), timer-counters including interval and watchdog timers, general purpose input/output (I/O or IO), memory card controllers such as Secure Digital (SD) MultiMediaCard (MMC) or similar, Universal Serial Bus (USB) interfaces, Mobile Industry Processor Interface (MIPI) interfaces and Joint Test Access Group (JTAG) test access ports. The processors (or cores) of the application circuitry 1005 may be coupled with or may include memory/storage elements and may be configured to execute instructions stored in the memory/storage to enable various applications or operating systems to run on the system 1000. In some implementations, the memory/storage elements may be on-chip memory circuitry, which may include any suitable volatile and/or non-volatile memory, such as DRAM, SRAM, EPROM, EEPROM, Flash memory, solid-state memory, and/or any other type of memory device technology, such as those discussed herein.

The processor(s) of application circuitry 1005 may include, for example, one or more processor cores (CPUs), one or more application processors, one or more graphics processing units (GPUs), one or more reduced instruction set computing (RISC) processors, one or more Acorn RISC Machine (ARM) processors, one or more complex instruction set computing (CISC) processors, one or more digital signal processors (DSP), one or more FPGAs, one or more PLDs, one or more ASICs, one or more microprocessors or controllers, or any suitable combination thereof. In some embodiments, the application circuitry 1005 may comprise, or may be, a special-purpose processor/controller to operate according to the various embodiments herein. As examples, the processor(s) of application circuitry 1005 may include one or more Intel Pentium®, Core®, or Xeon® processor(s); Advanced Micro Devices (AMD) Ryzen® processor(s), Accelerated Processing Units (APUs), or Epyc® processors; ARM-based processor(s) licensed from ARM Holdings, Ltd. such as the ARM Cortex-A family of processors and the ThunderX2@ provided by Cavium™, Inc.; a MIPS-based design from MIPS Technologies, Inc. such as MIPS Warrior P-class processors; and/or the like. In some embodiments, the system 1000 may not utilize application circuitry 1005, and instead may include a special-purpose processor/controller to process IP data received from an EPC or 5GC, for example.

In some implementations, the application circuitry 1005 may include one or more hardware accelerators, which may be microprocessors, programmable processing devices, or the like. The one or more hardware accelerators may include, for example, computer vision (CV) and/or deep learning (DL) accelerators. As examples, the programmable processing devices may be one or more a field-programmable devices (FPDs) such as field-programmable gate arrays (FPGAs) and the like; programmable logic devices (PLDs) such as complex PLDs (CPLDs), high-capacity PLDs (HCPLDs), and the like; ASICs such as structured ASICs and the like; programmable SoCs (PSoCs); and the like. In such implementations, the circuitry of application circuitry 1005 may comprise logic blocks or logic fabric, and other interconnected resources that may be programmed to perform various functions, such as the procedures, methods, functions, etc. of the various embodiments discussed herein. In such embodiments, the circuitry of application circuitry 1005 may include memory cells (e.g., erasable

programmable read-only memory (EPROM), electrically erasable programmable read-only memory (EEPROM), flash memory, static memory (e.g., static random access memory (SRAM), anti-fuses, etc.) used to store logic blocks, logic fabric, data, etc. in look-up-tables (LUTs) and the like.

The baseband circuitry **1010** may be implemented, for example, as a solder-down substrate including one or more integrated circuits, a single packaged integrated circuit soldered to a main circuit board or a multi-chip module containing two or more integrated circuits. The various hardware electronic elements of baseband circuitry **1010** are discussed infra with regard to FIG. **12**.

User interface circuitry **1050** may include one or more user interfaces designed to enable user interaction with the system **1000** or peripheral component interfaces designed to enable peripheral component interaction with the system **1000**. User interfaces may include, but are not limited to, one or more physical or virtual buttons (e.g., a reset button), one or more indicators (e.g., light emitting diodes (LEDs)), a physical keyboard or keypad, a mouse, a touchpad, a touchscreen, speakers or other audio emitting devices, microphones, a printer, a scanner, a headset, a display screen or display device, etc. Peripheral component interfaces may include, but are not limited to, a nonvolatile memory port, a universal serial bus (USB) port, an audio jack, a power supply interface, etc.

The radio front end modules (RFEMs) **1015** may comprise a millimeter wave (mmWave) RFEM and one or more sub-mmWave radio frequency integrated circuits (RFICs). In some implementations, the one or more sub-mmWave RFICs may be physically separated from the mmWave RFEM. The RFICs may include connections to one or more antennas or antenna arrays (see e.g., antenna array **1211** of FIG. XT infra), and the RFEM may be connected to multiple antennas. In alternative implementations, both mmWave and sub-mmWave radio functions may be implemented in the same physical RFEM **1015**, which incorporates both mmWave antennas and sub-mmWave.

The memory circuitry **1020** may include one or more of volatile memory including dynamic random access memory (DRAM) and/or synchronous dynamic random access memory (SDRAM), and nonvolatile memory (NVM) including high-speed electrically erasable memory (commonly referred to as Flash memory), phase change random access memory (PRAM), magnetoresistive random access memory (MRAM), etc., and may incorporate the three-dimensional (3D) cross-point (XPOINT) memories from Intel® and Micron®. Memory circuitry **1020** may be implemented as one or more of solder down packaged integrated circuits, socketed memory modules and plug-in memory cards.

The PMIC **1025** may include voltage regulators, surge protectors, power alarm detection circuitry, and one or more backup power sources such as a battery or capacitor. The power alarm detection circuitry may detect one or more of brown out (under-voltage) and surge (over-voltage) conditions. The power tee circuitry **1030** may provide for electrical power drawn from a network cable to provide both power supply and data connectivity to the infrastructure equipment **1000** using a single cable.

The network controller circuitry **1035** may provide connectivity to a network using a standard network interface protocol such as Ethernet, Ethernet over GRE Tunnels, Ethernet over Multiprotocol Label Switching (MPLS), or some other suitable protocol. Network connectivity may be provided to/from the infrastructure equipment **1000** via

network interface connector **1040** using a physical connection, which may be electrical (commonly referred to as a “copper interconnect”), optical, or wireless. The network controller circuitry **1035** may include one or more dedicated processors and/or FPGAs to communicate using one or more of the aforementioned protocols. In some implementations, the network controller circuitry **1035** may include multiple controllers to provide connectivity to other networks using the same or different protocols.

The positioning circuitry **1045** includes circuitry to receive and decode signals transmitted/broadcasted by a positioning network of a global navigation satellite system (GNSS). Examples of navigation satellite constellations (or GNSS) include United States’ Global Positioning System (GPS), Russia’s Global Navigation System (GLONASS), the European Union’s Galileo system, China’s BeiDou Navigation Satellite System, a regional navigation system or GNSS augmentation system (e.g., Navigation with Indian Constellation (NAVIC), Japan’s Quasi-Zenith Satellite System (QZSS), France’s Doppler Orbitography and Radio-positioning Integrated by Satellite (DORIS), etc.), or the like. The positioning circuitry **1045** comprises various hardware elements (e.g., including hardware devices such as switches, filters, amplifiers, antenna elements, and the like to facilitate OTA communications) to communicate with components of a positioning network, such as navigation satellite constellation nodes. In some embodiments, the positioning circuitry **1045** may include a Micro-Technology for Positioning, Navigation, and Timing (Micro-PNT) IC that uses a master timing clock to perform position tracking/estimation without GNSS assistance. The positioning circuitry **1045** may also be part of, or interact with, the baseband circuitry **1010** and/or RFEMs **1015** to communicate with the nodes and components of the positioning network. The positioning circuitry **1045** may also provide position data and/or time data to the application circuitry **1005**, which may use the data to synchronize operations with various infrastructure (e.g., RAN nodes **711**, etc.), or the like.

The components shown by FIG. **10** may communicate with one another using interface circuitry, which may include any number of bus and/or interconnect (IX) technologies such as industry standard architecture (ISA), extended ISA (EISA), peripheral component interconnect (PCI), peripheral component interconnect extended (PCIx), PCI express (PCIe), or any number of other technologies. The bus/IX may be a proprietary bus, for example, used in a SoC based system. Other bus/IX systems may be included, such as an I²C interface, an SPI interface, point to point interfaces, and a power bus, among others.

FIG. **11** illustrates an example of a platform **1100** (or “device **1100**”) in accordance with various embodiments. In embodiments, the computer platform **1100** may be suitable for use as UEs **701**, **702**, **801**, application servers **730**, and/or any other element/device discussed herein. The platform **1100** may include any combinations of the components shown in the example. The components of platform **1100** may be implemented as integrated circuits (ICs), portions thereof, discrete electronic devices, or other modules, logic, hardware, software, firmware, or a combination thereof adapted in the computer platform **1100**, or as components otherwise incorporated within a chassis of a larger system. The block diagram of FIG. **11** is intended to show a high level view of components of the computer platform **1100**. However, some of the components shown may be omitted,

additional components may be present, and different arrangement of the components shown may occur in other implementations.

Application circuitry **1105** includes circuitry such as, but not limited to one or more processors (or processor cores), cache memory, and one or more of LDOs, interrupt controllers, serial interfaces such as SPI, I²C or universal programmable serial interface module, RTC, timer-counters including interval and watchdog timers, general purpose I/O, memory card controllers such as SD MMC or similar, USB interfaces, MIPI interfaces, and JTAG test access ports. The processors (or cores) of the application circuitry **1105** may be coupled with or may include memory/storage elements and may be configured to execute instructions stored in the memory/storage to enable various applications or operating systems to run on the system **1100**. In some implementations, the memory/storage elements may be on-chip memory circuitry, which may include any suitable volatile and/or non-volatile memory, such as DRAM, SRAM, EPROM, EEPROM, Flash memory, solid-state memory, and/or any other type of memory device technology, such as those discussed herein.

The processor(s) of application circuitry **1005** may include, for example, one or more processor cores, one or more application processors, one or more GPUs, one or more RISC processors, one or more ARM processors, one or more CISC processors, one or more DSP, one or more FPGAs, one or more PLDs, one or more ASICs, one or more microprocessors or controllers, a multithreaded processor, an ultra-low voltage processor, an embedded processor, some other known processing element, or any suitable combination thereof. In some embodiments, the application circuitry **1005** may comprise, or may be, a special-purpose processor/controller to operate according to the various embodiments herein.

As examples, the processor(s) of application circuitry **1105** may include an Intel® Architecture Core™ based processor, such as a Quark™, an Atom™, an i3, an i5, an i7, or an MCU-class processor, or another such processor available from Intel® Corporation, Santa Clara, CA. The processors of the application circuitry **1105** may also be one or more of Advanced Micro Devices (AMD) Ryzen® processor(s) or Accelerated Processing Units (APUs); A5-A9 processor(s) from Apple® Inc., Snapdragon™ processor(s) from Qualcomm® Technologies, Inc., Texas Instruments, Inc.® Open Multimedia Applications Platform (OMAP)™ processor(s); a MIPS-based design from MIPS Technologies, Inc. such as MIPS Warrior M-class, Warrior I-class, and Warrior P-class processors; an ARM-based design licensed from ARM Holdings, Ltd., such as the ARM Cortex-A, Cortex-R, and Cortex-M family of processors; or the like. In some implementations, the application circuitry **1105** may be a part of a system on a chip (SoC) in which the application circuitry **1105** and other components are formed into a single integrated circuit, or a single package, such as the Edison™ or Galileo™ SoC boards from Intel® Corporation.

Additionally or alternatively, application circuitry **1105** may include circuitry such as, but not limited to, one or more a field-programmable devices (FPDs) such as FPGAs and the like; programmable logic devices (PLDs) such as complex PLDs (CPLDs), high-capacity PLDs (HCPLDs), and the like; ASICs such as structured ASICs and the like; programmable SoCs (PSoCs); and the like. In such embodiments, the circuitry of application circuitry **1105** may comprise logic blocks or logic fabric, and other interconnected resources that may be programmed to perform various

functions, such as the procedures, methods, functions, etc. of the various embodiments discussed herein. In such embodiments, the circuitry of application circuitry **1105** may include memory cells (e.g., erasable programmable read-only memory (EPROM), electrically erasable programmable read-only memory (EEPROM), flash memory, static memory (e.g., static random access memory (SRAM), anti-fuses, etc.)) used to store logic blocks, logic fabric, data, etc. in look-up tables (LUTs) and the like.

The baseband circuitry **1110** may be implemented, for example, as a solder-down substrate including one or more integrated circuits, a single packaged integrated circuit soldered to a main circuit board or a multi-chip module containing two or more integrated circuits. The various hardware electronic elements of baseband circuitry **1110** are discussed infra with regard to FIG. **12**.

The RFEMs **1115** may comprise a millimeter wave (mm-Wave) RFEM and one or more sub-mmWave radio frequency integrated circuits (RFICs). In some implementations, the one or more sub-mmWave RFICs may be physically separated from the mmWave RFEM. The RFICs may include connections to one or more antennas or antenna arrays (see e.g., antenna array **1211** of FIG. **12** infra), and the RFEM may be connected to multiple antennas. In alternative implementations, both mmWave and sub-mmWave radio functions may be implemented in the same physical RFEM **1115**, which incorporates both mmWave antennas and sub-mmWave.

The memory circuitry **1120** may include any number and type of memory devices used to provide for a given amount of system memory. As examples, the memory circuitry **1120** may include one or more of volatile memory including random access memory (RAM), dynamic RAM (DRAM) and/or synchronous dynamic RAM (SDRAM), and nonvolatile memory (NVM) including high-speed electrically erasable memory (commonly referred to as Flash memory), phase change random access memory (PRAM), magnetoresistive random access memory (MRAM), etc. The memory circuitry **1120** may be developed in accordance with a Joint Electron Devices Engineering Council (JEDEC) low power double data rate (LPDDR)-based design, such as LPDDR2, LPDDR3, LPDDR4, or the like. Memory circuitry **1120** may be implemented as one or more of solder down packaged integrated circuits, single die package (SDP), dual die package (DDP) or quad die package (Q17P), socketed memory modules, dual inline memory modules (DIMMs) including microDIMMs or MiniDIMMs, and/or soldered onto a motherboard via a ball grid array (BGA). In low power implementations, the memory circuitry **1120** may be on-die memory or registers associated with the application circuitry **1105**. To provide for persistent storage of information such as data, applications, operating systems and so forth, memory circuitry **1120** may include one or more mass storage devices, which may include, inter alia, a solid state disk drive (SSDD), hard disk drive (HDD), a micro HDD, resistance change memories, phase change memories, holographic memories, or chemical memories, among others. For example, the computer platform **1100** may incorporate the three-dimensional (3D) cross-point (XPOINT) memories from Intel® and Micron®.

Removable memory circuitry **1123** may include devices, circuitry, enclosures/housings, ports or receptacles, etc. used to couple portable data storage devices with the platform **1100**. These portable data storage devices may be used for mass storage purposes, and may include, for example, flash memory cards (e.g., Secure Digital (SD) cards, microSD

cards, xD picture cards, and the like), and USB flash drives, optical discs, external HDDs, and the like.

The platform **1100** may also include interface circuitry (not shown) that is used to connect external devices with the platform **1100**. The external devices connected to the platform **1100** via the interface circuitry include sensor circuitry **1121** and electro-mechanical components (EMCs) **1122**, as well as removable memory devices coupled to removable memory circuitry **1123**.

The sensor circuitry **1121** include devices, modules, or subsystems whose purpose is to detect events or changes in its environment and send the information (sensor data) about the detected events to some other a device, module, subsystem, etc. Examples of such sensors include, inter alia, inertia measurement units (IMUs) comprising accelerometers, gyroscopes, and/or magnetometers; microelectromechanical systems (MEMS) or nanoelectromechanical systems (NEMS) comprising 3-axis accelerometers, 3-axis gyroscopes, and/or magnetometers; level sensors; flow sensors; temperature sensors (e.g., thermistors); pressure sensors; barometric pressure sensors; gravimeters; altimeters; image capture devices (e.g., cameras or lensless apertures); light detection and ranging (LiDAR) sensors; proximity sensors (e.g., infrared radiation detector and the like), depth sensors, ambient light sensors, ultrasonic transceivers; microphones or other like audio capture devices; etc.

EMCs **1122** include devices, modules, or subsystems whose purpose is to enable platform **1100** to change its state, position, and/or orientation, or move or control a mechanism or (sub)system. Additionally, EMCs **1122** may be configured to generate and send messages/signalling to other components of the platform **1100** to indicate a current state of the EMCs **1122**. Examples of the EMCs **1122** include one or more power switches, relays including electromechanical relays (EMRs) and/or solid state relays (SSRs), actuators (e.g., valve actuators, etc.), an audible sound generator, a visual warning device, motors (e.g., DC motors, stepper motors, etc.), wheels, thrusters, propellers, claws, clamps, hooks, and/or other like electro-mechanical components. In embodiments, platform **1100** is configured to operate one or more EMCs **1122** based on one or more captured events and/or instructions or control signals received from a service provider and/or various clients.

In some implementations, the interface circuitry may connect the platform **1100** with positioning circuitry **1145**. The positioning circuitry **1145** includes circuitry to receive and decode signals transmitted/broadcasted by a positioning network of a GNSS. Examples of navigation satellite constellations (or GNSS) include United States' GPS, Russia's GLONASS, the European Union's Galileo system, China's BeiDou Navigation Satellite System, a regional navigation system or GNSS augmentation system (e.g., NAVIC), Japan's QZSS, France's DORIS, etc.), or the like. The positioning circuitry **1145** comprises various hardware elements (e.g., including hardware devices such as switches, filters, amplifiers, antenna elements, and the like to facilitate OTA communications) to communicate with components of a positioning network, such as navigation satellite constellation nodes. In some embodiments, the positioning circuitry **1145** may include a Micro-PNT IC that uses a master timing clock to perform position tracking/estimation without GNSS assistance. The positioning circuitry **1145** may also be part of, or interact with, the baseband circuitry **1010** and/or RFEMs **1115** to communicate with the nodes and components of the positioning network. The positioning circuitry **1145** may also provide position data and/or time data to the application circuitry **1105**, which may use the data to syn-

chronize operations with various infrastructure (e.g., radio base stations), for turn-by-turn navigation applications, or the like

In some implementations, the interface circuitry may connect the platform **1100** with Near-Field Communication (NFC) circuitry **1140**. NFC circuitry **1140** is configured to provide contactless, short-range communications based on radio frequency identification (RFID) standards, wherein magnetic field induction is used to enable communication between NFC circuitry **1140** and NFC-enabled devices external to the platform **1100** (e.g., an "NFC touchpoint"). NFC circuitry **1140** comprises an NFC controller coupled with an antenna element and a processor coupled with the NFC controller. The NFC controller may be a chip/IC providing NFC functionalities to the NFC circuitry **1140** by executing NFC controller firmware and an NFC stack. The NFC stack may be executed by the processor to control the NFC controller, and the NFC controller firmware may be executed by the NFC controller to control the antenna element to emit short-range RF signals. The RF signals may power a passive NFC tag (e.g., a microchip embedded in a sticker or wristband) to transmit stored data to the NFC circuitry **1140**, or initiate data transfer between the NFC circuitry **1140** and another active NFC device (e.g., a smartphone or an NFC-enabled POS terminal) that is proximate to the platform **1100**.

The driver circuitry **1146** may include software and hardware elements that operate to control particular devices that are embedded in the platform **1100**, attached to the platform **1100**, or otherwise communicatively coupled with the platform **1100**. The driver circuitry **1146** may include individual drivers allowing other components of the platform **1100** to interact with or control various input/output (I/O) devices that may be present within, or connected to, the platform **1100**. For example, driver circuitry **1146** may include a display driver to control and allow access to a display device, a touchscreen driver to control and allow access to a touchscreen interface of the platform **1100**, sensor drivers to obtain sensor readings of sensor circuitry **1121** and control and allow access to sensor circuitry **1121**, EMC drivers to obtain actuator positions of the EMCs **1122** and/or control and allow access to the EMCs **1122**, a camera driver to control and allow access to an embedded image capture device, audio drivers to control and allow access to one or more audio devices.

The power management integrated circuitry (PMIC) **1125** (also referred to as "power management circuitry **1125**") may manage power provided to various components of the platform **1100**. In particular, with respect to the baseband circuitry **1110**, the PMIC **1125** may control power-source selection, voltage scaling, battery charging, or DC-to-DC conversion. The PMIC **1125** may often be included when the platform **1100** is capable of being powered by a battery **1130**, for example, when the device is included in a UE **701**, **702**, **801**.

In some embodiments, the PMIC **1125** may control, or otherwise be part of, various power saving mechanisms of the platform **1100**. For example, if the platform **1100** is in an RRC_Connected state, where it is still connected to the RAN node as it expects to receive traffic shortly, then it may enter a state known as Discontinuous Reception Mode (DRX) after a period of inactivity. During this state, the platform **1100** may power down for brief intervals of time and thus save power. If there is no data traffic activity for an extended period of time, then the platform **1100** may transition off to an RRC_Idle state, where it disconnects from the network and does not perform operations such as channel quality

feedback, handover, etc. The platform **1100** goes into a very low power state and it performs paging where again it periodically wakes up to listen to the network and then powers down again. The platform **1100** may not receive data in this state; in order to receive data, it can then transition back to RRC_Connected state. An additional power saving mode may allow a device to be unavailable to the network for periods longer than a paging interval (ranging from seconds to a few hours). During this time, the device is unreachable to the network and may power down completely. Any data sent during this time incurs a large delay and it is assumed the delay is acceptable.

A battery **1130** may power the platform **1100**, although in some examples the platform **1100** may be mounted deployed in a fixed location, and may have a power supply coupled to an electrical grid. The battery **1130** may be a lithium ion battery, a metal-air battery, such as a zinc-air battery, an aluminum-air battery, a lithium-air battery, and the like. In some implementations, such as in V2X applications, the battery **1130** may be a typical lead-acid automotive battery.

In some implementations, the battery **1130** may be a "smart battery," which includes or is coupled with a Battery Management System (BMS) or battery monitoring integrated circuitry. The BMS may be included in the platform **1100** to track the state of charge (SoCh) of the battery **1130**. The BMS may be used to monitor other parameters of the battery **1130** to provide failure predictions, such as the state of health (SoH) and the state of function (SoF) of the battery **1130**. The BMS may communicate the information of the battery **1130** to the application circuitry **1105** or other components of the platform **1100**. The BMS may also include an analog-to-digital (ADC) convertor that allows the application circuitry **1105** to directly monitor the voltage of the battery **1130** or the current flow from the battery **1130**. The battery parameters may be used to determine actions that the platform **1100** may perform, such as transmission frequency, network operation, sensing frequency, and the like.

A power block, or other power supply coupled to an electrical grid may be coupled with the BMS to charge the battery **1130**. In some examples, the power block XS30 may be replaced with a wireless power receiver to obtain the power wirelessly, for example, through a loop antenna in the computer platform **1100**. In these examples, a wireless battery charging circuit may be included in the BMS. The specific charging circuits chosen may depend on the size of the battery **1130**, and thus, the current required. The charging may be performed using the Airfuel standard promulgated by the Airfuel Alliance, the Qi wireless charging standard promulgated by the Wireless Power Consortium, or the Rezence charging standard promulgated by the Alliance for Wireless Power, among others.

User interface circuitry **1150** includes various input/output (I/O) devices present within, or connected to, the platform **1100**, and includes one or more user interfaces designed to enable user interaction with the platform **1100** and/or peripheral component interfaces designed to enable peripheral component interaction with the platform **1100**. The user interface circuitry **1150** includes input device circuitry and output device circuitry. Input device circuitry includes any physical or virtual means for accepting an input including, inter alia, one or more physical or virtual buttons (e.g., a reset button), a physical keyboard, keypad, mouse, touchpad, touchscreen, microphones, scanner, headset, and/or the like. The output device circuitry includes any physical or virtual means for showing information or otherwise conveying information, such as sensor readings, actuator

position(s), or other like information. Output device circuitry may include any number and/or combinations of audio or visual display, including, inter alia, one or more simple visual outputs/indicators (e.g., binary status indicators (e.g., light emitting diodes (LEDs)) and multi-character visual outputs, or more complex outputs such as display devices or touchscreens (e.g., Liquid Crystal Displays (LCD), LED displays, quantum dot displays, projectors, etc.), with the output of characters, graphics, multimedia objects, and the like being generated or produced from the operation of the platform **1100**. The output device circuitry may also include speakers or other audio emitting devices, printer(s), and/or the like. In some embodiments, the sensor circuitry **1121** may be used as the input device circuitry (e.g., an image capture device, motion capture device, or the like) and one or more EMCs may be used as the output device circuitry (e.g., an actuator to provide haptic feedback or the like). In another example, NFC circuitry comprising an NFC controller coupled with an antenna element and a processing device may be included to read electronic tags and/or connect with another NFC-enabled device. Peripheral component interfaces may include, but are not limited to, a non-volatile memory port, a USB port, an audio jack, a power supply interface, etc.

Although not shown, the components of platform **1100** may communicate with one another using a suitable bus or interconnect (IX) technology, which may include any number of technologies, including ISA, EISA, PCI, PCIx, PCIe, a Time-Trigger Protocol (TTP) system, a FlexRay system, or any number of other technologies. The bus/IX may be a proprietary bus/IX, for example, used in a SoC based system. Other bus/IX systems may be included, such as an I²C interface, an SPI interface, point-to-point interfaces, and a power bus, among others.

FIG. 12 illustrates example components of baseband circuitry **1210** and radio front end modules (RFEM) **1215** in accordance with various embodiments. The baseband circuitry **1210** corresponds to the baseband circuitry **1010** and **1110** of FIGS. 10 and 11, respectively. The RFEM **1215** corresponds to the RFEM **1015** and **1115** of FIGS. 10 and 11, respectively. As shown, the RFEMs **1215** may include Radio Frequency (RF) circuitry **1206**, front-end module (FEM) circuitry **1208**, antenna array **1211** coupled together at least as shown.

The baseband circuitry **1210** includes circuitry and/or control logic configured to carry out various radio/network protocol and radio control functions that enable communication with one or more radio networks via the RF circuitry **1206**. The radio control functions may include, but are not limited to, signal modulation/demodulation, encoding/decoding, radio frequency shifting, etc. In some embodiments, modulation/demodulation circuitry of the baseband circuitry **1210** may include Fast-Fourier Transform (FFT), precoding, or constellation mapping/demapping functionality. In some embodiments, encoding/decoding circuitry of the baseband circuitry **1210** may include convolution, tail-biting convolution, turbo, Viterbi, or Low Density Parity Check (LDPC) encoder/decoder functionality. Embodiments of modulation/demodulation and encoder/decoder functionality are not limited to these examples and may include other suitable functionality in other embodiments. The baseband circuitry **1210** is configured to process baseband signals received from a receive signal path of the RF circuitry **1206** and to generate baseband signals for a transmit signal path of the RF circuitry **1206**. The baseband circuitry **1210** is configured to interface with application circuitry **1005/1105** (see FIGS. 10 and 11) for generation and processing of the

baseband signals and for controlling operations of the RF circuitry 1206. The baseband circuitry 1210 may handle various radio control functions.

The aforementioned circuitry and/or control logic of the baseband circuitry 1210 may include one or more single or multi-core processors. For example, the one or more processors may include a 3G baseband processor 1204A, a 4G/LTE baseband processor 1204B, a 5G/NR baseband processor 1204C, or some other baseband processor(s) 1204D for other existing generations, generations in development or to be developed in the future (e.g., sixth generation (6G), etc.). In other embodiments, some or all of the functionality of baseband processors 1204A-D may be included in modules stored in the memory 1204G and executed via a Central Processing Unit (CPU) 1204E. In other embodiments, some or all of the functionality of baseband processors 1204A-D may be provided as hardware accelerators (e.g., FPGAs, ASICs, etc.) loaded with the appropriate bit streams or logic blocks stored in respective memory cells. In various embodiments, the memory 1204G may store program code of a real-time OS (RTOS), which when executed by the CPU 1204E (or other baseband processor), is to cause the CPU 1204E (or other baseband processor) to manage resources of the baseband circuitry 1210, schedule tasks, etc. Examples of the RTOS may include Operating System Embedded (OSE)[™] provided by Enea®, Nucleus RTOS[™] provided by Mentor Graphics®, Versatile Real-Time Executive (VRTX) provided by Mentor Graphics®, ThreadX[™] provided by Express Logic®, FreeRTOS, REX OS provided by Qualcomm®, OKL4 provided by Open Kernel (OK) Labs®, or any other suitable RTOS, such as those discussed herein. In addition, the baseband circuitry 1210 includes one or more audio digital signal processor(s) (DSP) 1204F. The audio DSP(s) 1204F include elements for compression/decompression and echo cancellation and may include other suitable processing elements in other embodiments.

In some embodiments, each of the processors 1204A-1204E include respective memory interfaces to send/receive data to/from the memory 1204G. The baseband circuitry 1210 may further include one or more interfaces to communicatively couple to other circuitries/devices, such as an interface to send/receive data to/from memory external to the baseband circuitry 1210; an application circuitry interface to send/receive data to/from the application circuitry 1005/1105 of FIGS. 10-XT; an RF circuitry interface to send/receive data to/from RF circuitry 1206 of FIG. XT; a wireless hardware connectivity interface to send/receive data to/from one or more wireless hardware elements (e.g., Near Field Communication (NFC) components, Bluetooth®/Bluetooth® Low Energy components, Wi-Fi® components, and/or the like); and a power management interface to send/receive power or control signals to/from the PMIC 1125.

In alternate embodiments (which may be combined with the above described embodiments), baseband circuitry 1210 comprises one or more digital baseband systems, which are coupled with one another via an interconnect subsystem and to a CPU subsystem, an audio subsystem, and an interface subsystem. The digital baseband subsystems may also be coupled to a digital baseband interface and a mixed-signal baseband subsystem via another interconnect subsystem. Each of the interconnect subsystems may include a bus system, point-to-point connections, network-on-chip (NOC) structures, and/or some other suitable bus or interconnect technology, such as those discussed herein. The audio subsystem may include DSP circuitry, buffer memory, program

memory, speech processing accelerator circuitry, data converter circuitry such as analog-to-digital and digital-to-analog converter circuitry, analog circuitry including one or more of amplifiers and filters, and/or other like components. In an aspect of the present disclosure, baseband circuitry 1210 may include protocol processing circuitry with one or more instances of control circuitry (not shown) to provide control functions for the digital baseband circuitry and/or radio frequency circuitry (e.g., the radio front end modules 1215).

Although not shown by FIG. 12, in some embodiments, the baseband circuitry 1210 includes individual processing device(s) to operate one or more wireless communication protocols (e.g., a “multi-protocol baseband processor” or “protocol processing circuitry”) and individual processing device(s) to implement PHY layer functions. In these embodiments, the PHY layer functions include the aforementioned radio control functions. In these embodiments, the protocol processing circuitry operates or implements various protocol layers/entities of one or more wireless communication protocols. In a first example, the protocol processing circuitry may operate LTE protocol entities and/or 5G/NR protocol entities when the baseband circuitry 1210 and/or RF circuitry 1206 are part of mmWave communication circuitry or some other suitable cellular communication circuitry. In the first example, the protocol processing circuitry would operate MAC, RLC, PDCP, SDAP, RRC, and NAS functions. In a second example, the protocol processing circuitry may operate one or more IEEE-based protocols when the baseband circuitry 1210 and/or RF circuitry 1206 are part of a Wi-Fi communication system. In the second example, the protocol processing circuitry would operate Wi-Fi MAC and logical link control (LLC) functions. The protocol processing circuitry may include one or more memory structures (e.g., 1204G) to store program code and data for operating the protocol functions, as well as one or more processing cores to execute the program code and perform various operations using the data. The baseband circuitry 1210 may also support radio communications for more than one wireless protocol.

The various hardware elements of the baseband circuitry 1210 discussed herein may be implemented, for example, as a solder-down substrate including one or more integrated circuits (ICs), a single packaged IC soldered to a main circuit board or a multi-chip module containing two or more ICs. In one example, the components of the baseband circuitry 1210 may be suitably combined in a single chip or chipset, or disposed on a same circuit board. In another example, some or all of the constituent components of the baseband circuitry 1210 and RF circuitry 1206 may be implemented together such as, for example, a system on a chip (SoC) or System-in-Package (SiP). In another example, some or all of the constituent components of the baseband circuitry 1210 may be implemented as a separate SoC that is communicatively coupled with and RF circuitry 1206 (or multiple instances of RF circuitry 1206). In yet another example, some or all of the constituent components of the baseband circuitry 1210 and the application circuitry 1005/1105 may be implemented together as individual SoCs mounted to a same circuit board (e.g., a “multi-chip package”).

In some embodiments, the baseband circuitry 1210 may provide for communication compatible with one or more radio technologies. For example, in some embodiments, the baseband circuitry 1210 may support communication with an E-UTRAN or other WMAN, a WLAN, a WPAN. Embodiments in which the baseband circuitry 1210 is con-

figured to support radio communications of more than one wireless protocol may be referred to as multi-mode baseband circuitry.

RF circuitry **1206** may enable communication with wireless networks using modulated electromagnetic radiation through a non-solid medium. In various embodiments, the RF circuitry **1206** may include switches, filters, amplifiers, etc. to facilitate the communication with the wireless network. RF circuitry **1206** may include a receive signal path, which may include circuitry to down-convert RF signals received from the FEM circuitry **1208** and provide baseband signals to the baseband circuitry **1210**. RF circuitry **1206** may also include a transmit signal path, which may include circuitry to up-convert baseband signals provided by the baseband circuitry **1210** and provide RF output signals to the FEM circuitry **1208** for transmission.

In some embodiments, the receive signal path of the RF circuitry **1206** may include mixer circuitry **1206a**, amplifier circuitry **1206b** and filter circuitry **1206c**. In some embodiments, the transmit signal path of the RF circuitry **1206** may include filter circuitry **1206c** and mixer circuitry **1206a**. RF circuitry **1206** may also include synthesizer circuitry **1206d** for synthesizing a frequency for use by the mixer circuitry **1206a** of the receive signal path and the transmit signal path. In some embodiments, the mixer circuitry **1206a** of the receive signal path may be configured to down-convert RF signals received from the FEM circuitry **1208** based on the synthesized frequency provided by synthesizer circuitry **1206d**. The amplifier circuitry **1206b** may be configured to amplify the down-converted signals and the filter circuitry **1206c** may be a low-pass filter (LPF) or band-pass filter (BPF) configured to remove unwanted signals from the down-converted signals to generate output baseband signals. Output baseband signals may be provided to the baseband circuitry **1210** for further processing. In some embodiments, the output baseband signals may be zero-frequency baseband signals, although this is not a requirement. In some embodiments, mixer circuitry **1206a** of the receive signal path may comprise passive mixers, although the scope of the embodiments is not limited in this respect.

In some embodiments, the mixer circuitry **1206a** of the transmit signal path may be configured to up-convert input baseband signals based on the synthesized frequency provided by the synthesizer circuitry **1206d** to generate RF output signals for the FEM circuitry **1208**. The baseband signals may be provided by the baseband circuitry **1210** and may be filtered by filter circuitry **1206c**.

In some embodiments, the mixer circuitry **1206a** of the receive signal path and the mixer circuitry **1206a** of the transmit signal path may include two or more mixers and may be arranged for quadrature downconversion and upconversion, respectively. In some embodiments, the mixer circuitry **1206a** of the receive signal path and the mixer circuitry **1206a** of the transmit signal path may include two or more mixers and may be arranged for image rejection (e.g., Hartley image rejection). In some embodiments, the mixer circuitry **1206a** of the receive signal path and the mixer circuitry **1206a** of the transmit signal path may be arranged for direct downconversion and direct upconversion, respectively. In some embodiments, the mixer circuitry **1206a** of the receive signal path and the mixer circuitry **1206a** of the transmit signal path may be configured for super-heterodyne operation.

In some embodiments, the output baseband signals and the input baseband signals may be analog baseband signals, although the scope of the embodiments is not limited in this respect. In some alternate embodiments, the output baseband

signals and the input baseband signals may be digital baseband signals. In these alternate embodiments, the RF circuitry **1206** may include analog-to-digital converter (ADC) and digital-to-analog converter (DAC) circuitry and the baseband circuitry **1210** may include a digital baseband interface to communicate with the RF circuitry **1206**.

In some dual-mode embodiments, a separate radio IC circuitry may be provided for processing signals for each spectrum, although the scope of the embodiments is not limited in this respect.

In some embodiments, the synthesizer circuitry **1206d** may be a fractional-N synthesizer or a fractional N/N+1 synthesizer, although the scope of the embodiments is not limited in this respect as other types of frequency synthesizers may be suitable. For example, synthesizer circuitry **1206d** may be a delta-sigma synthesizer, a frequency multiplier, or a synthesizer comprising a phase-locked loop with a frequency divider.

The synthesizer circuitry **1206d** may be configured to synthesize an output frequency for use by the mixer circuitry **1206a** of the RF circuitry **1206** based on a frequency input and a divider control input. In some embodiments, the synthesizer circuitry **1206d** may be a fractional N/N+1 synthesizer.

In some embodiments, frequency input may be provided by a voltage controlled oscillator (VCO), although that is not a requirement. Divider control input may be provided by either the baseband circuitry **1210** or the application circuitry **1005/1105** depending on the desired output frequency. In some embodiments, a divider control input (e.g., N) may be determined from a look-up table based on a channel indicated by the application circuitry **1005/1105**.

Synthesizer circuitry **1206d** of the RF circuitry **1206** may include a divider, a delay-locked loop (DLL), a multiplexer and a phase accumulator. In some embodiments, the divider may be a dual modulus divider (DMD) and the phase accumulator may be a digital phase accumulator (DPA). In some embodiments, the DMD may be configured to divide the input signal by either N or N+1 (e.g., based on a carry out) to provide a fractional division ratio. In some example embodiments, the DLL may include a set of cascaded, tunable, delay elements, a phase detector, a charge pump and a D-type flip-flop. In these embodiments, the delay elements may be configured to break a VCO period up into Nd equal packets of phase, where Nd is the number of delay elements in the delay line. In this way, the DLL provides negative feedback to help ensure that the total delay through the delay line is one VCO cycle.

In some embodiments, synthesizer circuitry **1206d** may be configured to generate a carrier frequency as the output frequency, while in other embodiments, the output frequency may be a multiple of the carrier frequency (e.g., twice the carrier frequency, four times the carrier frequency) and used in conjunction with quadrature generator and divider circuitry to generate multiple signals at the carrier frequency with multiple different phases with respect to each other. In some embodiments, the output frequency may be a LO frequency (f_{LO}). In some embodiments, the RF circuitry **1206** may include an IQ/polar converter.

FEM circuitry **1208** may include a receive signal path, which may include circuitry configured to operate on RF signals received from antenna array **1211**, amplify the received signals and provide the amplified versions of the received signals to the RF circuitry **1206** for further processing. FEM circuitry **1208** may also include a transmit signal path, which may include circuitry configured to amplify signals for transmission provided by the RF cir-

circuitry **1206** for transmission by one or more of antenna elements of antenna array **1211**. In various embodiments, the amplification through the transmit or receive signal paths may be done solely in the RF circuitry **1206**, solely in the FEM circuitry **1208**, or in both the RF circuitry **1206** and the FEM circuitry **1208**.

In some embodiments, the FEM circuitry **1208** may include a TX/RX switch to switch between transmit mode and receive mode operation. The FEM circuitry **1208** may include a receive signal path and a transmit signal path. The receive signal path of the FEM circuitry **1208** may include an LNA to amplify received RF signals and provide the amplified received RF signals as an output (e.g., to the RF circuitry **1206**). The transmit signal path of the FEM circuitry **1208** may include a power amplifier (PA) to amplify input RF signals (e.g., provided by RF circuitry **1206**), and one or more filters to generate RF signals for subsequent transmission by one or more antenna elements of the antenna array **1211**.

The antenna array **1211** comprises one or more antenna elements, each of which is configured convert electrical signals into radio waves to travel through the air and to convert received radio waves into electrical signals. For example, digital baseband signals provided by the baseband circuitry **1210** is converted into analog RF signals (e.g., modulated waveform) that will be amplified and transmitted via the antenna elements of the antenna array **1211** including one or more antenna elements (not shown). The antenna elements may be omnidirectional, direction, or a combination thereof. The antenna elements may be formed in a multitude of arrangements as are known and/or discussed herein. The antenna array **1211** may comprise microstrip antennas or printed antennas that are fabricated on the surface of one or more printed circuit boards. The antenna array **1211** may be formed in as a patch of metal foil (e.g., a patch antenna) in a variety of shapes, and may be coupled with the RF circuitry **1206** and/or FEM circuitry **1208** using metal transmission lines or the like.

Processors of the application circuitry **1005/1105** and processors of the baseband circuitry **1210** may be used to execute elements of one or more instances of a protocol stack. For example, processors of the baseband circuitry **1210**, alone or in combination, may be used execute Layer 3, Layer 2, or Layer 1 functionality, while processors of the application circuitry **1005/1105** may utilize data (e.g., packet data) received from these layers and further execute Layer 4 functionality (e.g., TCP and UDP layers). As referred to herein, Layer 3 may comprise a RRC layer, described in further detail below. As referred to herein, Layer 2 may comprise a MAC layer, an RLC layer, and a PDCP layer, described in further detail below. As referred to herein, Layer 1 may comprise a PHY layer of a UE/RAN node, described in further detail below.

FIG. **13** illustrates various protocol functions that may be implemented in a wireless communication device according to various embodiments. In particular, FIG. **13** includes an arrangement **1300** showing interconnections between various protocol layers/entities. The following description of FIG. **13** is provided for various protocol layers/entities that operate in conjunction with the 5G/NR system standards and LTE system standards, but some or all of the aspects of FIG. **13** may be applicable to other wireless communication network systems as well.

The protocol layers of arrangement **1300** may include one or more of PHY **1310**, MAC **1320**, RLC **1330**, PDCP **1340**, SDAP **1347**, RRC **1355**, and NAS layer **1357**, in addition to other higher layer functions not illustrated. The protocol

layers may include one or more service access points (e.g., items **1359**, **1356**, **1350**, **1349**, **1345**, **1335**, **1325**, and **1315** in FIG. **13**) that may provide communication between two or more protocol layers.

The PHY **1310** may transmit and receive physical layer signals **1305** that may be received from or transmitted to one or more other communication devices. The physical layer signals **1305** may comprise one or more physical channels, such as those discussed herein. The PHY **1310** may further perform link adaptation or adaptive modulation and coding (AMC), power control, cell search (e.g., for initial synchronization and handover purposes), and other measurements used by higher layers, such as the RRC **1355**. The PHY **1310** may still further perform error detection on the transport channels, forward error correction (FEC) coding/decoding of the transport channels, modulation/demodulation of physical channels, interleaving, rate matching, mapping onto physical channels, and MIMO antenna processing. In embodiments, an instance of PHY **1310** may process requests from and provide indications to an instance of MAC **1320** via one or more PHY-SAP **1315**. According to some embodiments, requests and indications communicated via PHY-SAP **1315** may comprise one or more transport channels.

Instance(s) of MAC **1320** may process requests from, and provide indications to, an instance of RLC **1330** via one or more MAC-SAPs **1325**. These requests and indications communicated via the MAC-SAP **1325** may comprise one or more logical channels. The MAC **1320** may perform mapping between the logical channels and transport channels, multiplexing of MAC SDUs from one or more logical channels onto TBs to be delivered to PHY **1310** via the transport channels, de-multiplexing MAC SDUs to one or more logical channels from TBs delivered from the PHY **1310** via transport channels, multiplexing MAC SDUs onto TBs, scheduling information reporting, error correction through HARQ, and logical channel prioritization.

Instance(s) of RLC **1330** may process requests from and provide indications to an instance of PDCP **1340** via one or more radio link control service access points (RLC-SAP) **1335**. These requests and indications communicated via RLC-SAP **1335** may comprise one or more RLC channels. The RLC **1330** may operate in a plurality of modes of operation, including: Transparent Mode™, Unacknowledged Mode (UM), and Acknowledged Mode (AM). The RLC **1330** may execute transfer of upper layer protocol data units (PDUs), error correction through automatic repeat request (ARQ) for AM data transfers, and concatenation, segmentation and reassembly of RLC SDUs for UM and AM data transfers. The RLC **1330** may also execute re-segmentation of RLC data PDUs for AM data transfers, reorder RLC data PDUs for UM and AM data transfers, detect duplicate data for UM and AM data transfers, discard RLC SDUs for UM and AM data transfers, detect protocol errors for AM data transfers, and perform RLC re-establishment.

Instance(s) of PDCP **1340** may process requests from and provide indications to instance(s) of RRC **1355** and/or instance(s) of SDAP **1347** via one or more packet data convergence protocol service access points (PDCP-SAP) **1345**. These requests and indications communicated via PDCP-SAP **1345** may comprise one or more radio bearers. The PDCP **1340** may execute header compression and decompression of IP data, maintain PDCP Sequence Numbers (SNs), perform in-sequence delivery of upper layer PDUs at re-establishment of lower layers, eliminate duplicates of lower layer SDUs at re-establishment of lower

layers for radio bearers mapped on RLC AM, cipher and decipher control plane data, perform integrity protection and integrity verification of control plane data, control timer-based discard of data, and perform security operations (e.g., ciphering, deciphering, integrity protection, integrity verification, etc.).

Instance(s) of SDAP **1347** may process requests from and provide indications to one or more higher layer protocol entities via one or more SDAP-SAP **1349**. These requests and indications communicated via SDAP-SAP **1349** may comprise one or more QoS flows. The SDAP **1347** may map QoS flows to DRBs, and vice versa, and may also mark QFIs in DL and UL packets. A single SDAP entity **1347** may be configured for an individual PDU session. In the UL direction, the NG-RAN **710** may control the mapping of QoS Flows to DRB(s) in two different ways, reflective mapping or explicit mapping. For reflective mapping, the SDAP **1347** of a UE **701** may monitor the QFIs of the DL packets for each DRB, and may apply the same mapping for packets flowing in the UL direction. For a DRB, the SDAP **1347** of the UE **701** may map the UL packets belonging to the QoS flows(s) corresponding to the QoS flow ID(s) and PDU session observed in the DL packets for that DRB. To enable reflective mapping, the NG-RAN **910** may mark DL packets over the Uu interface with a QoS flow ID. The explicit mapping may involve the RRC **1355** configuring the SDAP **1347** with an explicit QoS flow to DRB mapping rule, which may be stored and followed by the SDAP **1347**. In embodiments, the SDAP **1347** may only be used in NR implementations and may not be used in LTE implementations.

The RRC **1355** may configure, via one or more management service access points (M-SAP), aspects of one or more protocol layers, which may include one or more instances of PHY **1310**, MAC **1320**, RLC **1330**, PDCP **1340** and SDAP **1347**. In embodiments, an instance of RRC **1355** may process requests from and provide indications to one or more NAS entities **1357** via one or more RRC-SAPs **1356**. The main services and functions of the RRC **1355** may include broadcast of system information (e.g., included in MIBs or SIBs related to the NAS), broadcast of system information related to the access stratum (AS), paging, establishment, maintenance and release of an RRC connection between the UE **701** and RAN **710** (e.g., RRC connection paging, RRC connection establishment, RRC connection modification, and RRC connection release), establishment, configuration, maintenance and release of point to point Radio Bearers, security functions including key management, inter-RAT mobility, and measurement configuration for UE measurement reporting. The MIBs and SIBs may comprise one or more IEs, which may each comprise individual data fields or data structures.

The NAS **1357** may form the highest stratum of the control plane between the UE **701** and the AMF **921**. The NAS **1357** may support the mobility of the UEs **701** and the session management procedures to establish and maintain IP connectivity between the UE **701** and a P-GW in LTE systems.

According to various embodiments, one or more protocol entities of arrangement **1300** may be implemented in UEs **701**, RAN nodes **711**, AMF **921** in NR implementations or MME **821** in LTE implementations, UPF **902** in NR implementations or S-GW **822** and P-GW **823** in LTE implementations, or the like to be used for control plane or user plane communications protocol stack between the aforementioned devices. In such embodiments, one or more protocol entities that may be implemented in one or more of UE **701**, gNB **711**, AMF **921**, etc. may communicate with a respective peer

protocol entity that may be implemented in or on another device using the services of respective lower layer protocol entities to perform such communication. In some embodiments, a gNB-CU of the gNB **711** may host the RRC **1355**, SDAP **1347**, and PDCP **1340** of the gNB that controls the operation of one or more gNB-DUs, and the gNB-DUs of the gNB **711** may each host the RLC **1330**, MAC **1320**, and PHY **1310** of the gNB **711**.

In a first example, a control plane protocol stack may comprise, in order from highest layer to lowest layer, NAS **1357**, RRC **1355**, PDCP **1340**, RLC **1330**, MAC **1320**, and PHY **1310**. In this example, upper layers **1360** may be built on top of the NAS **1357**, which includes an IP layer **1361**, an SCTP **1362**, and an application layer signaling protocol (AP) **1363**.

In NR implementations, the AP **1363** may be an NG application protocol layer (NGAP or NG-AP) **1363** for the NG interface **713** defined between the NG-RAN node **711** and the AMF **921**, or the AP **1363** may be an Xn application protocol layer (XnAP or Xn-AP) **1363** for the Xn interface **712** that is defined between two or more RAN nodes **711**.

The NG-AP **1363** may support the functions of the NG interface **713** and may comprise Elementary Procedures (EPs). An NG-AP EP may be a unit of interaction between the NG-RAN node **711** and the AMF **921**. The NG-AP **1363** services may comprise two groups: UE-associated services (e.g., services related to a UE **701**, **702**) and non-UE-associated services (e.g., services related to the whole NG interface instance between the NG-RAN node **711** and AMF **921**). These services may include functions including, but not limited to: a paging function for the sending of paging requests to NG-RAN nodes **711** involved in a particular paging area; a UE context management function for allowing the AMF **921** to establish, modify, and/or release a UE context in the AMF **921** and the NG-RAN node **711**; a mobility function for UEs **701** in ECM-CONNECTED mode for intra-system HOs to support mobility within NG-RAN and inter-system HOs to support mobility from/to EPS systems; a NAS Signaling Transport function for transporting or rerouting NAS messages between UE **701** and AMF **921**; a NAS node selection function for determining an association between the AMF **921** and the UE **701**; NG interface management function(s) for setting up the NG interface and monitoring for errors over the NG interface; a warning message transmission function for providing means to transfer warning messages via NG interface or cancel ongoing broadcast of warning messages; a Configuration Transfer function for requesting and transferring of RAN configuration information (e.g., SON information, performance measurement (PM) data, etc.) between two RAN nodes **711** via CN **720**; and/or other like functions.

The XnAP **1363** may support the functions of the Xn interface **712** and may comprise XnAP basic mobility procedures and XnAP global procedures. The XnAP basic mobility procedures may comprise procedures used to handle UE mobility within the NG RAN **711** (or E-UTRAN **810**), such as handover preparation and cancellation procedures, SN Status Transfer procedures, UE context retrieval and UE context release procedures, RAN paging procedures, dual connectivity related procedures, and the like. The XnAP global procedures may comprise procedures that are not related to a specific UE **701**, such as Xn interface setup and reset procedures, NG-RAN update procedures, cell activation procedures, and the like.

In LTE implementations, the AP **1363** may be an S1 Application Protocol layer (S1-AP) **1363** for the S1 interface **713** defined between an E-UTRAN node **711** and an MME,

or the AP **1363** may be an X2 application protocol layer (X2AP or X2-AP) **1363** for the X2 interface **712** that is defined between two or more E-UTRAN nodes **711**.

The S1 Application Protocol layer (S1-AP) **1363** may support the functions of the S1 interface, and similar to the NG-AP discussed previously, the S1-AP may comprise S1-AP EPs. An S1-AP EP may be a unit of interaction between the E-UTRAN node **711** and an MME **821** within an LTE CN **720**. The S1-AP **1363** services may comprise two groups: UE-associated services and non UE-associated services. These services perform functions including, but not limited to: E-UTRAN Radio Access Bearer (E-RAB) management, UE capability indication, mobility, NAS signaling transport, RAN Information Management (RIM), and configuration transfer.

The X2AP **1363** may support the functions of the X2 interface **712** and may comprise X2AP basic mobility procedures and X2AP global procedures. The X2AP basic mobility procedures may comprise procedures used to handle UE mobility within the E-UTRAN **720**, such as handover preparation and cancellation procedures, SN Status Transfer procedures, UE context retrieval and UE context release procedures, RAN paging procedures, dual connectivity related procedures, and the like. The X2AP global procedures may comprise procedures that are not related to a specific UE **701**, such as X2 interface setup and reset procedures, load indication procedures, error indication procedures, cell activation procedures, and the like.

The SCTP layer (alternatively referred to as the SCTP/IP layer) **1362** may provide guaranteed delivery of application layer messages (e.g., NGAP or XnAP messages in NR implementations, or S1-AP or X2AP messages in LTE implementations). The SCTP **1362** may ensure reliable delivery of signaling messages between the RAN node **711** and the AMF **921**/MME **821** based, in part, on the IP protocol, supported by the IP **1361**. The Internet Protocol layer (IP) **1361** may be used to perform packet addressing and routing functionality. In some implementations the IP layer **1361** may use point-to-point transmission to deliver and convey PDUs. In this regard, the RAN node **711** may comprise L2 and L1 layer communication links (e.g., wired or wireless) with the MME/AMF to exchange information.

In a second example, a user plane protocol stack may comprise, in order from highest layer to lowest layer, SDAP **1347**, PDCP **1340**, RLC **1330**, MAC **1320**, and PHY **1310**. The user plane protocol stack may be used for communication between the UE **701**, the RAN node **711**, and UPF **902** in NR implementations or an S-GW **822** and P-GW **823** in LTE implementations. In this example, upper layers **1351** may be built on top of the SDAP **1347**, and may include a user datagram protocol (UDP) and IP security layer (UDP/IP) **1352**, a General Packet Radio Service (GPRS) Tunneling Protocol for the user plane layer (GTP-U) **1353**, and a User Plane PDU layer (UP PDU) **1363**.

The transport network layer **1354** (also referred to as a “transport layer”) may be built on IP transport, and the GTP-U **1353** may be used on top of the UDP/IP layer **1352** (comprising a UDP layer and IP layer) to carry user plane PDUs (UP-PDUs). The IP layer (also referred to as the “Internet layer”) may be used to perform packet addressing and routing functionality. The IP layer may assign IP addresses to user data packets in any of IPv4, IPv6, or PPP formats, for example.

The GTP-U **1353** may be used for carrying user data within the GPRS core network and between the radio access network and the core network. The user data transported can be packets in any of IPv4, IPv6, or PPP formats, for

example. The UDP/IP **1352** may provide checksums for data integrity, port numbers for addressing different functions at the source and destination, and encryption and authentication on the selected data flows. The RAN node **711** and the S-GW **822** may utilize an S1-U interface to exchange user plane data via a protocol stack comprising an L1 layer (e.g., PHY **1310**), an L2 layer (e.g., MAC **1320**, RLC **1330**, PDCP **1340**, and/or SDAP **1347**), the UDP/IP layer **1352**, and the GTP-U **1353**. The S-GW **822** and the P-GW **823** may utilize an S5/S8a interface to exchange user plane data via a protocol stack comprising an L1 layer, an L2 layer, the UDP/IP layer **1352**, and the GTP-U **1353**. As discussed previously, NAS protocols may support the mobility of the UE **701** and the session management procedures to establish and maintain IP connectivity between the UE **701** and the P-GW **823**.

Moreover, although not shown by FIG. **13**, an application layer may be present above the AP **1363** and/or the transport network layer **1354**. The application layer may be a layer in which a user of the UE **701**, RAN node **711**, or other network element interacts with software applications being executed, for example, by application circuitry **1005** or application circuitry **1105**, respectively. The application layer may also provide one or more interfaces for software applications to interact with communications systems of the UE **701** or RAN node **711**, such as the baseband circuitry **1210**. In some implementations the IP layer and/or the application layer may provide the same or similar functionality as layers 5-7, or portions thereof, of the Open Systems Interconnection (OSI) model (e.g., OSI Layer 7—the application layer, OSI Layer 6—the presentation layer, and OSI Layer 5—the session layer).

FIG. **14** is a block diagram illustrating components, according to some example embodiments, able to read instructions from a machine-readable or computer-readable medium (e.g., a non-transitory machine-readable storage medium) and perform any one or more of the methodologies discussed herein. Specifically, FIG. **14** shows a diagrammatic representation of hardware resources **1400** including one or more processors (or processor cores) **1410**, one or more memory/storage devices **1420**, and one or more communication resources **1430**, each of which may be communicatively coupled via a bus **1440**. For embodiments where node virtualization (e.g., NFV) is utilized, a hypervisor **1402** may be executed to provide an execution environment for one or more network slices/sub-slices to utilize the hardware resources **1400**.

The processors **1410** may include, for example, a processor **1412** and a processor **1414**. The processor(s) **1410** may be, for example, a central processing unit (CPU), a reduced instruction set computing (RISC) processor, a complex instruction set computing (CISC) processor, a graphics processing unit (GPU), a DSP such as a baseband processor, an ASIC, an FPGA, a radio-frequency integrated circuit (RFIC), another processor (including those discussed herein), or any suitable combination thereof.

The memory/storage devices **1420** may include main memory, disk storage, or any suitable combination thereof. The memory/storage devices **1420** may include, but are not limited to, any type of volatile or nonvolatile memory such as dynamic random access memory (DRAM), static random access memory (SRAM), erasable programmable read-only memory (EPROM), electrically erasable programmable read-only memory (EEPROM), Flash memory, solid-state storage, etc.

The communication resources **1430** may include interconnection or network interface components or other suit-

able devices to communicate with one or more peripheral devices **1404** or one or more databases **1406** via a network **1408**. For example, the communication resources **1430** may include wired communication components (e.g., for coupling via USB), cellular communication components, NFC components, Bluetooth® (or Bluetooth® Low Energy) components, Wi-Fi® components, and other communication components.

Instructions **1450** may comprise software, a program, an application, an applet, an app, or other executable code for causing at least any of the processors **1410** to perform any one or more of the methodologies discussed herein. The instructions **1450** may reside, completely or partially, within at least one of the processors **1410** (e.g., within the processor's cache memory), the memory/storage devices **1420**, or any suitable combination thereof. Furthermore, any portion of the instructions **1450** may be transferred to the hardware resources **1400** from any combination of the peripheral devices **1404** or the databases **1406**. Accordingly, the memory of processors **1410**, the memory/storage devices **1420**, the peripheral devices **1404**, and the databases **1406** are examples of computer-readable and machine-readable media.

For one or more embodiments, at least one of the components set forth in one or more of the preceding figures may be configured to perform one or more operations, techniques, processes, and/or methods as set forth in the example section below. For example, the baseband circuitry as described above in connection with one or more of the preceding figures may be configured to operate in accordance with one or more of the examples set forth below. For another example, circuitry associated with a UE, base station, network element, etc. as described above in connection with one or more of the preceding figures may be configured to operate in accordance with one or more of the examples set forth below in the example section.

FIG. **15** illustrates a flowchart **1500** that describes a UE, such as UE **701**, **702**, **801**, **901** or **1000**, identifying an aggressor beam of an aggressor UE according to embodiments of the disclosure. Method **1500** can be performed by processing logic that can comprise hardware (e.g., circuitry, dedicated logic, programmable logic, microcode, etc.), software (e.g., instructions executing on a processing device), or a combination thereof. It is to be appreciated that not all steps may be needed to perform the disclosure provided herein. Further, some of the steps may be performed simultaneously, or in a different order than shown in FIG. **15**, as will be understood by a person of ordinary skill in the art.

In step **1502**, the UE identifies an aggressor UE based on an original crosslink interference (CLI) measurement report from a victim UE. In some embodiments, the UE transmits an original CLI measurement configuration to the victim UE. In response, the UE receives the original CLI measurement report from the victim UE.

In step **1504**, the UE transmits a CLI Reference Signal (CLI-RS) refinement request message to the aggressor UE. The CLI-RS refinement request message can include an identifier for the aggressor UE.

In step **1506**, the UE receives a CLI-RS refinement response message from the aggressor UE. The UE can receive the CLI-RS refinement response message based on the aggressor UE accepting the CLI-RS refinement request message. The CLI-RS refinement response message can include an indication of whether the CLI-RS refinement request message was accepted by the aggressor UE.

In step **1508**, the UE transmits an updated CLI measurement configuration to the victim UE. The UE can transmit

the updated CLI measurement configuration to the victim UE based on the CLI-RS refinement response message.

In step **1510**, the UE receive an updated CLI measurement report from the victim UE.

In step **1512**, the UE identifies an aggressor beam of the aggressor UE based on the updated CLI measurement report.

The processes and functions described in FIG. **15** can be performed by one or more of application circuitry **1005** or **1105**, baseband circuitry **1010** or **1110**, or processors **1412** and **1414**.

FIG. **16** illustrates a flowchart **1600** that describes a UE, such as UE **701**, **702**, **801**, **901** or **1000**, performing CLI mitigation for a victim UE according to embodiments of the disclosure. Method **1600** can be performed by processing logic that can comprise hardware (e.g., circuitry, dedicated logic, programmable logic, microcode, etc.), software (e.g., instructions executing on a processing device), or a combination thereof. It is to be appreciated that not all steps may be needed to perform the disclosure provided herein. Further, some of the steps may be performed simultaneously, or in a different order than shown in FIG. **16**, as will be understood by a person of ordinary skill in the art.

In step **1602**, the UE identifies an aggressor UE based on a crosslink interference (CLI) measurement report from a victim UE. In some embodiments, the UE transmits a CLI measurement configuration to the victim UE. In response, the UE receives the CLI measurement report from the victim UE.

In step **1604**, the UE transmits a transmission information exchange request message to the aggressor UE. The transmission information exchange request message can include an identifier for the aggressor UE. The transmission information exchange request message can further include a transmission information type for the aggressor UE. The transmission information type can be a download/uplink (DL/UL) configuration, power control parameters, a resource allocation, a scheduling decision, or transmission (TX) beam information of the aggressor UE.

In step **1606**, the UE receives a transmission information exchange response message from the aggressor UE. The UE can receive the transmission information exchange response message based on the aggressor UE accepting the transmission information exchange request message. The transmission information exchange response message can include an indication of whether the transmission information exchange request message was accepted by the aggressor UE.

The transmission information exchange response message can include transmission information for the aggressor UE. The transmission information for the aggressor UE can include a DL/UL configuration, power control parameters, a resource allocation, a scheduling decision, or TX beam information of the aggressor UE.

The transmission information exchange response message can also include a cell identifier, a Bandwidth Part (BWP) identifier, an identifier for the aggressor UE, and a Supplementary Uplink (SUL) indication.

In step **1608**, the UE transmits a CLI mitigation request message to the victim UE. The UE can transmit the CLI mitigation request message to the victim UE based on the transmission information for the aggressor UE. The UE can transmit the CLI mitigation request message to the victim UE to perform CLI mitigation at the victim UE.

In some embodiments, the CLI mitigation request message includes an instruction for the victim UE to schedule

DL transmission based at least in part on the victim UE being in a DL slot for neighboring cells.

In some embodiments, the CLI mitigation request message includes an instruction for the victim UE to use one or more beams for a DL reception.

In some embodiments, the CLI mitigation request message includes an instruction to increase a DL transmit power for the victim UE.

In some embodiments, the CLI mitigation request message includes an instruction to schedule the victim UE on a different time-frequency resource than the aggressor UE.

The processes and functions described in FIG. 16 can be performed by one or more of application circuitry 1005 or 1105, baseband circuitry 1010 or 1110, or processors 1412 and 1414.

FIG. 17 illustrates a flowchart 1700 that describes a UE, such as UE 701, 702, 801, 901 or 1000, performing CLI mitigation for an aggressor UE according to embodiments of the disclosure. Method 1700 can be performed by processing logic that can comprise hardware (e.g., circuitry, dedicated logic, programmable logic, microcode, etc.), software (e.g., instructions executing on a processing device), or a combination thereof. It is to be appreciated that not all steps may be needed to perform the disclosure provided herein. Further, some of the steps may be performed simultaneously, or in a different order than shown in FIG. 17, as will be understood by a person of ordinary skill in the art.

In step 1702, the UE identifies an aggressor UE based on a crosslink interference (CLI) measurement report from a victim UE. In some embodiments, the UE transmits a CLI measurement configuration to the victim UE. In response, the UE receives the CLI measurement report from the victim UE.

In step 1704, the UE transmits a CLI mitigation request message to the aggressor UE. The UE can transmit the CLI mitigation request message to the aggressor UE to perform CLI mitigation at the aggressor UE.

The CLI mitigation request message can include an identifier for the aggressor UE, an identifier for the victim UE, the CLI measurement report from the victim UE, and transmission information for the victim UE.

In some embodiments, the CLI mitigation request message includes an instruction for the aggressor UE to schedule uplink (UL) transmission based on the aggressor UE being in a UL slot in the victim UE.

In some embodiments, the CLI mitigation request message includes an instruction for the aggressor UE to use one or more beams for an UL transmission.

In some embodiments, the CLI mitigation request message includes an instruction to decrease an UL transmit power for the aggressor UE.

In some embodiments, the CLI mitigation request message includes an instruction to schedule the aggressor UE on a different time-frequency resource than the victim UE.

In step 1706, the UE receives a CLI mitigation response message from the aggressor UE. The CLI mitigation response message can include an indication of whether the CLI mitigation request message was accepted by the aggressor UE. The CLI mitigation response message can further include transmission information for the aggressor UE. The transmission information can include downlink/uplink (DL/UL) configuration, power control parameters, a resource allocation, a scheduling decision, or transmission (TX) beam information for the aggressor UE.

The processes and functions described in FIG. 17 can be performed by one or more of application circuitry 1005 or 1105, baseband circuitry 1010 or 1110, or processors 1412 and 1414.

EXAMPLES

Example 1 may include a method of performing a CLI-RS configuration.

Example 2 may include the method of example 1 or some other example herein, wherein said performing the CLI-RS configuration comprises requesting, by a gNB, an aggressor's gNB to reconfigure CLI-RS configuration to enable finer CLI measurement granularity

Example 3 may include a CLI-RS refinement request message that includes an aggressor UE's ID.

Example 4 may include a CLI-RS refinement response message that includes a CLI-RS transmission configuration for the aggressor UE.

Example 5 may include a procedure of network coordination for victim side CLI mitigation is defined: a gNB can request an aggressor gNB's transmission information to enable victim side CLI mitigation.

Example 6 may include a transmission information exchange request message. The request message specifies the aggressor UE ID and the required transmission information type. Possible information types:

- a DL/UL configuration
- Power control parameters
- Resource allocation and scheduling decision
- Tx beam information

Example 7 may include a transmission information exchange response message. The response message includes the Cell ID, BWP ID, aggressor UE ID, SUL indication, and required transmission information, which includes:

- DL/UL configuration
- Power control parameters
- Resource allocation and scheduling decision
- Tx beam information of the aggressor UE.

Example 8 may include be based on various exchanged transmission information, a gNB performs the victim side CLI mitigation schemes. It has the following options:

- Based on exchanged DL/UL configurations, a gNB schedules a victim UE for DL transmission only when it is a DL slot for all neighboring cells.
- Based on exchanged transmit beam information, a gNB advises a victim UE on which receive beam(s) to use for DL reception, via TCI-states
- Based on exchanged power control parameters, a gNB increases the DL transmit power for a victim UE.
- Based on exchanged resource allocation and scheduling decisions, a gNB avoids scheduling a victim UE on the same time-frequency resource as its aggressor UE.

Example 9 may include a procedure of network coordination for aggressor side CLI mitigation is defined: a gNB can request an aggressor's gNB to perform aggressor side CLI mitigation based on transmission information it shared in the request

Example 10 may include CLI mitigation request message is defined. The request message specifies the aggressor UE ID, victim UE ID, and UE's CLI measurement reports. It also forwards victim's transmission information, which includes victim UE's:

- DL/UL configuration
- Power control parameters
- Resource allocation and scheduling decision
- Tx beam information

Example 11 may include CLI mitigation response message is defined. The response message has an acceptance or denial indication.

Example 12 may include based on various exchanged transmission information, a gNB has the following options for aggressor side CLI mitigation schemes

Based on exchanged DL/UL configurations, a gNB schedules the aggressor UE for UL transmission only when it is also a UL slot in the victim's cells.

Based on exchanged transmit beam information, a gNB advises the aggressor UE on which transmit beam(s) to use for UL transmission, via RRC spatialRelationInfo or L1 SRI

Based on exchanged power control parameters, a gNB decreases the aggressor UE's UL transmit power, via power control commands.

Based on exchanged resource allocation and scheduling decisions, a gNB avoids scheduling the aggressor UE on the same time-frequency resource as its victim.

Example 13 may include gNB prioritizes the CLI mitigation response based on the CLI measurement values attached in the CLI mitigation request.

Example 14 may include proposed network coordination for CLI mitigation schemes and messages can be conveyed over X2, Xn, and F1 interface.

Example Z01 may include an apparatus comprising means to perform one or more elements of a method described in or related to any of examples 1-14, or any other method or process described herein.

Example Z02 may include one or more non-transitory computer-readable media comprising instructions to cause an electronic device, upon execution of the instructions by one or more processors of the electronic device, to perform one or more elements of a method described in or related to any of examples 1-14, or any other method or process described herein.

Example Z03 may include an apparatus comprising logic, modules, or circuitry to perform one or more elements of a method described in or related to any of examples 1-14, or any other method or process described herein.

Example Z04 may include a method, technique, or process as described in or related to any of examples 1-14, or portions or parts thereof.

Example Z05 may include an apparatus comprising: one or more processors and one or more computer-readable media comprising instructions that, when executed by the one or more processors, cause the one or more processors to perform the method, techniques, or process as described in or related to any of examples 1-14, or portions thereof.

Example Z06 may include a signal as described in or related to any of examples 1-14, or portions or parts thereof.

Example Z07 may include a signal in a wireless network as shown and described herein.

Example Z08 may include a method of communicating in a wireless network as shown and described herein.

Example Z09 may include a system for providing wireless communication as shown and described herein.

Example Z10 may include a device for providing wireless communication as shown and described herein

Any of the above-described examples may be combined with any other example (or combination of examples), unless explicitly stated otherwise. The foregoing description of one or more implementations provides illustration and description, but is not intended to be exhaustive or to limit the scope of embodiments to the precise form disclosed.

Modifications and variations are possible in light of the above teachings or may be acquired from practice of various embodiments.

Abbreviations

For the purposes of the present document, the following abbreviations may apply to the examples and embodiments discussed herein but are not meant to be limiting.

3GPP Third Generation Partnership Project
 4G Fourth Generation
 5G Fifth Generation
 5GC 5G Core network
 ACK Acknowledgement
 AF Application Function
 AM Acknowledged Mode
 AMBR Aggregate Maximum Bit Rate
 AMF Access and Mobility Management Function
 AN Access Network
 ANR Automatic Neighbour Relation
 AP Application Protocol, Antenna Port, Access Point
 API Application Programming Interface
 APN Access Point Name
 ARP Allocation and Retention Priority
 ARQ Automatic Repeat Request
 AS Access Stratum
 ASN.1 Abstract Syntax Notation One
 AUSF Authentication Server Function
 AWGN Additive White Gaussian Noise
 BCH Broadcast Channel
 BER Bit Error Ratio
 BFD Beam Failure Detection
 BLER Block Error Rate
 BPSK Binary Phase Shift Keying
 BRAS Broadband Remote Access Server
 BSS Business Support System
 BS Base Station
 BSR Buffer Status Report
 BW Bandwidth
 BWP Bandwidth Part
 C-RNTI Cell Radio Network Temporary Identity
 CA Carrier Aggregation, Certification Authority
 CAPEX CAPital EXpenditure
 CBRA Contention Based Random Access
 CC Component Carrier, Country Code, Cryptographic
 Checksum
 CCA Clear Channel Assessment
 CCE Control Channel Element
 CCCH Common Control Channel
 CE Coverage Enhancement
 CDM Content Delivery Network
 CDMA Code-Division Multiple Access
 CFRA Contention Free Random Access
 CG Cell Group
 CI Cell Identity
 CID Cell-ID (e.g., positioning method)
 CIM Common Information Model
 CIR Carrier to Interference Ratio
 CK Cipher Key
 CM Connection Management, Conditional Mandatory
 CMAS Commercial Mobile Alert Service
 CMD Command
 CMS Cloud Management System
 CO Conditional Optional
 CoMP Coordinated Multi-Point
 CORESET Control Resource Set
 COTS Commercial Off-The-Shelf

CP Control Plane, Cyclic Prefix, Connection Point
 CPD Connection Point Descriptor
 CPE Customer Premise Equipment
 CPICH Common Pilot Channel
 CQI Channel Quality Indicator
 CPU CSI processing unit, Central Processing Unit
 C/R Command/Response field bit
 CRAN Cloud Radio Access Network, Cloud RAN
 CRB Common Resource Block
 CRC Cyclic Redundancy Check
 CRI Channel-State Information Resource Indicator, CSI-
 RS Resource Indicator
 C-RNTI Cell RNTI
 CS Circuit Switched
 CSAR Cloud Service Archive
 CSI Channel-State Information
 CSI-IM CSI Interference Measurement
 CSI-RS CSI Reference Signal
 CSI-RSRP CSI reference signal received power
 CSI-RSRQ CSI reference signal received quality
 CSI-SINR CSI signal-to-noise and interference ratio
 CSMA Carrier Sense Multiple Access
 CSMA/CA CSMA with collision avoidance
 CSS Common Search Space, Cell-specific Search Space
 CTS Clear-to-Send
 CW Codeword
 CWS Contention Window Size
 D2D Device-to-Device
 DC Dual Connectivity, Direct Current
 DCI Downlink Control Information
 DF Deployment Flavour
 DL Downlink
 DMTF Distributed Management Task Force
 DPDK Data Plane Development Kit
 DM-RS, DMRS Demodulation Reference Signal
 DN Data network
 DRB Data Radio Bearer
 DRS Discovery Reference Signal
 DRX Discontinuous Reception
 DSL Domain Specific Language, Digital Subscriber Line
 DSLAM DSL Access Multiplexer
 DwPTS Downlink Pilot Time Slot
 E-LAN Ethernet Local Area Network
 E2E End-to-End
 ECCA extended clear channel assessment, extended CCA
 ECCE Enhanced Control Channel Element, Enhanced
 CCE
 ED Energy Detection
 EDGE Enhanced Data Rates for GSM Evolution (GSM
 Evolution)
 EGMF Exposure Governance Management Function
 EGPRS Enhanced GPRS
 EIR Equipment Identity Register
 eLAA enhanced Licensed Assisted Access, enhanced
 LAA
 EM Element Manager
 eMBB Enhanced Mobile Broadband
 EMS Element Management System
 eNB evolved NodeB, E-UTRAN Node B
 EN-DC E-UTRA-NR Dual Connectivity
 EPC Evolved Packet Core
 EPDCCH enhanced PDCCH, enhanced Physical Down-
 link Control Channel
 EPRE Energy per resource element
 EPS Evolved Packet System
 EREG enhanced REG, enhanced resource element groups
 ETSI European Telecommunications Standards Institute

ETWS Earthquake and Tsunami Warning System
 eUICC embedded UICC, embedded Universal Integrated
 Circuit Card
 E-UTRA Evolved UTRA
 E-UTRAN Evolved UTRAN
 EV2X Enhanced V2X
 F1AP F1 Application Protocol
 F1-C F1 Control plane interface
 F1-U F1 User plane interface
 FACCH Fast Associated Control Channel
 FACCH/F Fast Associated Control Channel/Full rate
 FACCH/H Fast Associated Control Channel/Half rate
 FACH Forward Access Channel
 FAUSCH Fast Uplink Signalling Channel
 FB Functional Block
 FBI Feedback Information
 FCC Federal Communications Commission
 FCCH Frequency Correction Channel
 FDD Frequency Division Duplex
 FDM Frequency Division Multiplex
 FDMA Frequency Division Multiple Access
 FE Front End
 FEC Forward Error Correction
 FFS For Further Study
 FFT Fast Fourier Transformation
 feLAA further enhanced Licensed Assisted Access, fur-
 ther enhanced LAA
 FN Frame Number
 FPGA Field-Programmable Gate Array
 FR Frequency Range
 G-RNTI GERAN Radio Network Temporary Identity
 GERAN GSM EDGE RAN, GSM EDGE Radio Access
 Network
 GGSN Gateway GPRS Support Node
 GLONASS GLObal'naya NAvigatsionnaya Sputnik-
 ovaya Sistema (Engl.: Global Navigation Satellite Sys-
 tem)
 gNB Next Generation NodeB
 gNB-CU gNB-centralized unit, Next Generation NodeB
 centralized unit
 gNB-DU gNB-distributed unit, Next Generation NodeB
 distributed unit
 GNSS Global Navigation Satellite System
 GPRS General Packet Radio Service
 GSM Global System for Mobile Communications,
 Groupe Spécial Mobile
 GTP GPRS Tunneling Protocol
 GTP-U GPRS Tunneling Protocol for User Plane
 GTS Go To Sleep Signal (related to WUS)
 GUMMEI Globally Unique MME Identifier
 GUTI Globally Unique Temporary UE Identity
 HARQ Hybrid ARQ, Hybrid Automatic Repeat Request
 HANDO, HO Handover
 HFN HyperFrame Number
 HHO Hard Handover
 HLR Home Location Register
 HN Home Network
 HO Handover
 HPLMN Home Public Land Mobile Network
 HSDPA High Speed Downlink Packet Access
 HSN Hopping Sequence Number
 HSPA High Speed Packet Access
 HSS Home Subscriber Server
 HSUPA High Speed Uplink Packet Access
 HTTP Hyper Text Transfer Protocol
 HTTPS Hyper Text Transfer Protocol Secure (https is
 http/1.1 over SSL, i.e. port 443)

I-Block Information Block
 ICCID Integrated Circuit Card Identification
 ICIC Inter-Cell Interference Coordination
 ID Identity, identifier
 IDFT Inverse Discrete Fourier Transform
 IE Information element
 IBE In-Band Emission
 IEEE Institute of Electrical and Electronics Engineers
 IEI Information Element Identifier
 IEIDL Information Element Identifier Data Length
 IETF Internet Engineering Task Force
 IF Infrastructure
 IM Interference Measurement, Intermodulation, IP Multimedia
 IMC IMS Credentials
 IMEI International Mobile Equipment Identity
 IMG1 International mobile group identity
 IMPI IP Multimedia Private Identity
 IMPU IP Multimedia Public identity
 IMS IP Multimedia Subsystem
 IMSI International Mobile Subscriber Identity
 IoT Internet of Things
 IP Internet Protocol
 Ipvsec IP Security, Internet Protocol Security
 IP-CAN IP-Connectivity Access Network
 IP-M IP Multicast
 IPv4 Internet Protocol Version 4
 IPv6 Internet Protocol Version 6
 IR Infrared
 IS In Sync
 IRP Integration Reference Point
 ISDN Integrated Services Digital Network
 ISIM IM Services Identity Module
 ISO International Organisation for Standardisation
 ISP Internet Service Provider
 IWF Interworking-Function
 I-WLAN Interworking WLAN
 K Constraint length of the convolutional code, USIM Individual key
 kB Kilobyte (1000 bytes)
 kbps kilo-bits per second
 Kc Ciphering key
 Ki Individual subscriber authentication key
 KPI Key Performance Indicator
 KQI Key Quality Indicator
 KSI Key Set Identifier
 ksp/s kilo-symbols per second
 KVM Kernel Virtual Machine
 L1 Layer 1 (physical layer)
 L1-RSRP Layer 1 reference signal received power
 L2 Layer 2 (data link layer)
 L3 Layer 3 (network layer)
 LAA Licensed Assisted Access
 LAN Local Area Network
 LBT Listen Before Talk
 LCM LifeCycle Management
 LCR Low Chip Rate
 LCS Location Services
 LCID Logical Channel ID
 LI Layer Indicator
 LLC Logical Link Control, Low Layer Compatibility
 LPLMN Local PLMN
 LPP LTE Positioning Protocol
 LSB Least Significant Bit
 LTE Long Term Evolution
 LWA LTE-WLAN aggregation

LWIP LTE/WLAN Radio Level Integration with IPsec Tunnel
 LTE Long Term Evolution
 M2M Machine-to-Machine
 5 MAC Medium Access Control (protocol layering context)
 MAC Message authentication code (security/encryption context)
 MAC-A MAC used for authentication and key agreement (TSG T WG3 context)
 10 MAC-I MAC used for data integrity of signalling messages (TSG T WG3 context)
 MANO Management and Orchestration
 MBMS Multimedia Broadcast and Multicast Service
 MBSFN Multimedia Broadcast multicast service Single Frequency Network
 15 MCC Mobile Country Code
 MCG Master Cell Group
 MCOT Maximum Channel Occupancy Time
 MCS Modulation and coding scheme
 20 MDAF Management Data Analytics Function
 MDAS Management Data Analytics Service
 MDT Minimization of Drive Tests
 ME Mobile Equipment
 MeNB master eNB
 25 MER Message Error Ratio
 MGL Measurement Gap Length
 MGRP Measurement Gap Repetition Period
 MIB Master Information Block, Management Information Base
 30 MIMO Multiple Input Multiple Output
 MLC Mobile Location Centre
 MM Mobility Management
 MME Mobility Management Entity
 MN Master Node
 35 MO Measurement Object, Mobile Originated
 MPBCH MTC Physical Broadcast CHannel
 MPDCCCH MTC Physical Downlink Control CHannel
 MPDSCH MTC Physical Downlink Shared CHannel
 MPRACH MTC Physical Random Access CHannel
 40 MPUSCH MTC Physical Uplink Shared Channel
 MPLS MultiProtocol Label Switching
 MS Mobile Station
 MSB Most Significant Bit
 MSC Mobile Switching Centre
 45 MSI Minimum System Information, MCH Scheduling Information
 MSID Mobile Station Identifier
 MSIN Mobile Station Identification Number
 MSISDN Mobile Subscriber ISDN Number
 50 MT Mobile Terminated, Mobile Termination
 MTC Machine-Type Communications
 mMTC massive MTC, massive Machine-Type Communications
 MU-MIMO Multi User MIMO
 55 MWUS MTC wake-up signal, MTC WUS
 NACK Negative Acknowledgement
 NAI Network Access Identifier
 NAS Non-Access Stratum, Non-Access Stratum layer
 NCT Network Connectivity Topology
 60 NEC Network Capability Exposure
 NE-DC NR-E-UTRA Dual Connectivity
 NEF Network Exposure Function
 NF Network Function
 NFP Network Forwarding Path
 65 NFPD Network Forwarding Path Descriptor
 NFV Network Functions Virtualization
 NFVI NFV Infrastructure

51

NFVO NFV Orchestrator
 NG Next Generation, Next Gen
 NGEN-DC NG-RAN E-UTRA-NR Dual Connectivity
 NM Network Manager
 NMS Network Management System 5
 N-PoP Network Point of Presence
 NMIB, N-MIB Narrowband MIB
 NPBCH Narrowband Physical Broadcast CHannel
 NPDCCH Narrowband Physical Downlink Control
 CHannel 10
 NPDSCH Narrowband Physical Downlink Shared CHan-
 nel
 NPRACH Narrowband Physical Random Access CHan-
 nel
 NPUSCH Narrowband Physical Uplink Shared CHannel 15
 NPSS Narrowband Primary Synchronization Signal
 NSSS Narrowband Secondary Synchronization Signal
 NR New Radio, Neighbour Relation
 NRF NF Repository Function
 NRS Narrowband Reference Signal 20
 NS Network Service
 NSA Non-Standalone operation mode
 NSD Network Service Descriptor
 NSR Network Service Record
 NSSAI Network Slice Selection Assistance Information 25
 S-NNSAI Single-NSSAI
 NSSF Network Slice Selection Function
 NW Network
 NWUS Narrowband wake-up signal, Narrowband WUS
 NZP Non-Zero Power 30
 O&M Operation and Maintenance
 ODU2 Optical channel Data Unit—type 2
 OFDM Orthogonal Frequency Division Multiplexing
 OFDMA Orthogonal Frequency Division Multiple Access
 OOB Out-of-band 35
 OOS Out of Sync
 OPEX OPerating EXpense
 OSI Other System Information
 OSS Operations Support System
 OTA over-the-air 40
 PAPR Peak-to-Average Power Ratio
 PAR Peak to Average Ratio
 PBCH Physical Broadcast Channel
 PC Power Control, Personal Computer
 PCC Primary Component Carrier, Primary CC 45
 PCell Primary Cell
 PCI Physical Cell ID, Physical Cell Identity
 PCEF Policy and Charging Enforcement Function
 PCF Policy Control Function
 PCRF Policy Control and Charging Rules Function 50
 PDCP Packet Data Convergence Protocol, Packet Data
 Convergence Protocol layer
 PDCCH Physical Downlink Control Channel
 PDCP Packet Data Convergence Protocol
 PDN Packet Data Network, Public Data Network 55
 PDSCH Physical Downlink Shared Channel
 PDU Protocol Data Unit
 PEI Permanent Equipment Identifiers
 PFD Packet Flow Description
 P-GW PDN Gateway 60
 PHICH Physical hybrid-ARQ indicator channel
 PHY Physical layer
 PLMN Public Land Mobile Network
 PIN Personal Identification Number
 PM Performance Measurement 65
 PMI Precoding Matrix Indicator
 PNF Physical Network Function

52

PNF Physical Network Function Descriptor
 PNFR Physical Network Function Record
 POC PTT over Cellular
 PP, PTP Point-to-Point
 PPP Point-to-Point Protocol
 PRACH Physical RACH
 PRB Physical resource block
 PRG Physical resource block group
 ProSe Proximity Services, Proximity-Based Service
 PRS Positioning Reference Signal
 PRR Packet Reception Radio
 PS Packet Services
 PSBCH Physical Sidelink Broadcast Channel
 PSDCH Physical Sidelink Downlink Channel
 PSCCH Physical Sidelink Control Channel
 PSSCH Physical Sidelink Shared Channel
 PSCell Primary SCell
 PSS Primary Synchronization Signal
 PSTN Public Switched Telephone Network
 PT-RS Phase-tracking reference signal
 PTT Push-to-Talk
 PUCCH Physical Uplink Control Channel
 PUSCH Physical Uplink Shared Channel
 QAM Quadrature Amplitude Modulation
 QCI QoS class of identifier
 QCL Quasi co-location
 QFI QoS Flow ID, QoS Flow Identifier
 QoS Quality of Service
 QPSK Quadrature (Quaternary) Phase Shift Keying
 QZSS Quasi-Zenith Satellite System
 RA-RNTI Random Access RNTI
 RAB Radio Access Bearer, Random Access Burst
 RACH Random Access Channel
 RADIUS Remote Authentication Dial In User Service
 RAN Radio Access Network 35
 RAND RANDom number (used for authentication)
 RAR Random Access Response
 RAT Radio Access Technology
 RAU Routing Area Update
 RB Resource block, Radio Bearer 40
 RBG Resource block group
 REG Resource Element Group
 Rel Release
 REQ REQuest
 RF Radio Frequency 45
 RI Rank Indicator
 RIV Resource indicator value
 RL Radio Link
 RLC Radio Link Control, Radio Link Control layer
 RLC AM RLC Acknowledged Mode
 RLC UM RLC Unacknowledged Mode
 RLF Radio Link Failure
 RLM Radio Link Monitoring
 RLM-RS Reference Signal for RLM
 RM Registration Management
 RMC Reference Measurement Channel
 RMSI Remaining MSI, Remaining Minimum System
 Information
 RN Relay Node
 RNC Radio Network Controller 60
 RNL Radio Network Layer
 RNTI Radio Network Temporary Identifier
 ROHC ROBust Header Compression
 RRC Radio Resource Control, Radio Resource Control
 layer 65
 RRM Radio Resource Management
 RS Reference Signal

53

RSRP Reference Signal Received Power
 RSRQ Reference Signal Received Quality
 RSSI Received Signal Strength Indicator
 RSU Road Side Unit
 RSTD Reference Signal Time difference 5
 RTP Real Time Protocol
 RTS Ready-To-Send
 RTT Round Trip Time
 Rx Reception, Receiving, Receiver
 S1AP S1 Application Protocol 10
 S1-MME S1 for the control plane
 S1-U S1 for the user plane
 S-GW Serving Gateway
 S-RNTI SRNC Radio Network Temporary Identity
 S-TMSI SAE Temporary Mobile Station Identifier 15
 SA Standalone operation mode
 SAE System Architecture Evolution
 SAP Service Access Point
 SAPD Service Access Point Descriptor
 SAPI Service Access Point Identifier 20
 SCC Secondary Component Carrier, Secondary CC
 SCell Secondary Cell
 SC-FDMA Single Carrier Frequency Division Multiple
 Access
 SCG Secondary Cell Group 25
 SCM Security Context Management
 SCS Subcarrier Spacing
 SCTP Stream Control Transmission Protocol
 SDAP Service Data Adaptation Protocol, Service Data
 Adaptation Protocol layer 30
 SDL Supplementary Downlink
 SDNF Structured Data Storage Network Function
 SDP Service Discovery Protocol (Bluetooth related)
 SDSF Structured Data Storage Function
 SDU Service Data Unit 35
 SEAF Security Anchor Function
 SeNB secondary eNB
 SEPP Security Edge Protection Proxy
 SFI Slot format indication
 SFTD Space-Frequency Time Diversity, SFN and frame 40
 timing difference
 SFN System Frame Number
 SgNB Secondary gNB
 SGSN Serving GPRS Support Node
 S-GW Serving Gateway 45
 SI System Information
 SI-RNTI System Information RNTI
 SIB System Information Block
 SIM Subscriber Identity Module
 SIP Session Initiated Protocol 50
 SiP System in Package
 SL Sidelink
 SLA Service Level Agreement
 SM Session Management
 SMF Session Management Function 55
 SMS Short Message Service
 SMSF SMS Function
 SMTc SSB-based Measurement Timing Configuration
 SN Secondary Node, Sequence Number
 SoC System on Chip 60
 SON Self-Organizing Network
 SpCell Special Cell
 SP-CSI-RNTI Semi-Persistent CSI RNTI
 SPS Semi-Persistent Scheduling
 SQN Sequence number 65
 SR Scheduling Request
 SRB Signalling Radio Bearer

54

SRS Sounding Reference Signal
 SS Synchronization Signal
 SSB Synchronization Signal Block, SS/PBCH Block
 SSBRI SS/PBCH Block Resource Indicator, Synchroni-
 zation Signal Block Resource Indicator
 SSC Session and Service Continuity
 SS-RSRP Synchronization Signal based Reference Signal
 Received Power
 SS-RSRQ Synchronization Signal based Reference Sig-
 nal Received Quality 10
 SS-SINR Synchronization Signal based Signal to Noise
 and Interference Ratio
 SSS Secondary Synchronization Signal
 SSSG Search Space Set Group
 SSSIF Search Space Set Indicator 15
 SST Slice/Service Types
 SU-MIMO Single User MIMO
 SUL Supplementary Uplink
 TA Timing Advance, Tracking Area
 TAC Tracking Area Code
 TAG Timing Advance Group
 TAU Tracking Area Update
 TB Transport Block
 TBS Transport Block Size
 TBD To Be Defined 25
 TCI Transmission Configuration Indicator
 TCP Transmission Communication Protocol
 TDD Time Division Duplex
 TDM Time Division Multiplexing
 TDMA Time Division Multiple Access
 TE Terminal Equipment
 TEID Tunnel End Point Identifier
 TFT Traffic Flow Template
 TMSI Temporary Mobile Subscriber Identity
 TNL Transport Network Layer 35
 TPC Transmit Power Control
 TPMI Transmitted Precoding Matrix Indicator
 TR Technical Report
 TRP, TRxP Transmission Reception Point
 TRS Tracking Reference Signal
 TRx Transceiver
 TS Technical Specifications, Technical Standard
 TTI Transmission Time Interval
 Tx Transmission, Transmitting, Transmitter
 U-RNTI UTRAN Radio Network Temporary Identity 45
 UART Universal Asynchronous Receiver and Transmitter
 UCI Uplink Control Information
 UE User Equipment or user element
 UDM Unified Data Management
 UDP User Datagram Protocol 50
 UDSF Unstructured Data Storage Network Function
 UICC Universal Integrated Circuit Card
 UL Uplink
 UM Unacknowledged Mode
 UML Unified Modelling Language 55
 UMTS Universal Mobile Telecommunications System
 UP User Plane
 UPF User Plane Function
 URI Uniform Resource Identifier
 URL Uniform Resource Locator 60
 URLLC Ultra-Reliable and Low Latency
 USB Universal Serial Bus
 USIM Universal Subscriber Identity Module
 USS UE-specific search space
 UTRA UMTS Terrestrial Radio Access 65
 UTRAN Universal Terrestrial Radio Access Network
 UwPTS Uplink Pilot Time Slot

V2I Vehicle-to-Infrastructure
 V2P Vehicle-to-Pedestrian
 V2V Vehicle-to-Vehicle
 V2X Vehicle-to-everything
 VIM Virtualized Infrastructure Manager
 VL Virtual Link,
 VLAN Virtual LAN, Virtual Local Area Network
 VM Virtual Machine
 VNF Virtualized Network Function
 VNFFG VNF Forwarding Graph
 VNFFGD VNF Forwarding Graph Descriptor
 VNFM VNF Manager
 VoIP Voice-over-IP, Voice-over-Internet Protocol
 VPLMN Visited Public Land Mobile Network
 VPN Virtual Private Network
 VRB Virtual Resource Block
 WiMAX Worldwide Interoperability for Microwave
 Access
 WLAN Wireless Local Area Network
 WMAN Wireless Metropolitan Area Network
 WPAN Wireless Personal Area Network
 X2-C X2-Control plane
 X2-U X2-User plane
 XML eXtensible Markup Language
 XRES EXpected user RESponse
 XOR eXclusive OR
 ZC Zadoff-Chu
 ZP Zero Power

Terminology

For the purposes of the present document, the following terms and definitions are applicable to the examples and embodiments discussed herein.

The term “circuitry” as used herein refers to, is part of, or includes hardware components such as an electronic circuit, a logic circuit, a processor (shared, dedicated, or group) and/or memory (shared, dedicated, or group), an Application Specific Integrated Circuit (ASIC), a field-programmable device (FPD) (e.g., a field-programmable gate array (FPGA), a programmable logic device (PLD), a complex PLD (CPLD), a high-capacity PLD (HCPLD), a structured ASIC, or a programmable SoC), digital signal processors (DSPs), etc., that are configured to provide the described functionality. In some embodiments, the circuitry may execute one or more software or firmware programs to provide at least some of the described functionality. The term “circuitry” may also refer to a combination of one or more hardware elements (or a combination of circuits used in an electrical or electronic system) with the program code used to carry out the functionality of that program code. In these embodiments, the combination of hardware elements and program code may be referred to as a particular type of circuitry.

The term “processor circuitry” as used herein refers to, is part of, or includes circuitry capable of sequentially and automatically carrying out a sequence of arithmetic or logical operations, or recording, storing, and/or transferring digital data. The term “processor circuitry” may refer to one or more application processors, one or more baseband processors, a physical central processing unit (CPU), a single-core processor, a dual-core processor, a triple-core processor, a quad-core processor, and/or any other device capable of executing or otherwise operating computer-executable instructions, such as program code, software modules, and/or functional processes. The terms “application

circuitry” and/or “baseband circuitry” may be considered synonymous to, and may be referred to as, “processor circuitry.”

The term “interface circuitry” as used herein refers to, is part of, or includes circuitry that enables the exchange of information between two or more components or devices. The term “interface circuitry” may refer to one or more hardware interfaces, for example, buses, I/O interfaces, peripheral component interfaces, network interface cards, and/or the like.

The term “user equipment” or “UE” as used herein refers to a device with radio communication capabilities and may describe a remote user of network resources in a communications network. The term “user equipment” or “UE” may be considered synonymous to, and may be referred to as, client, mobile, mobile device, mobile terminal, user terminal, mobile unit, mobile station, mobile user, subscriber, user, remote station, access agent, user agent, receiver, radio equipment, reconfigurable radio equipment, reconfigurable mobile device, etc. Furthermore, the term “user equipment” or “UE” may include any type of wireless/wired device or any computing device including a wireless communications interface.

The term “network element” as used herein refers to physical or virtualized equipment and/or infrastructure used to provide wired or wireless communication network services. The term “network element” may be considered synonymous to and/or referred to as a networked computer, networking hardware, network equipment, network node, router, switch, hub, bridge, radio network controller, RAN device, RAN node, gateway, server, virtualized VNF, NFVI, and/or the like.

The term “computer system” as used herein refers to any type interconnected electronic devices, computer devices, or components thereof. Additionally, the term “computer system” and/or “system” may refer to various components of a computer that are communicatively coupled with one another. Furthermore, the term “computer system” and/or “system” may refer to multiple computer devices and/or multiple computing systems that are communicatively coupled with one another and configured to share computing and/or networking resources.

The term “appliance,” “computer appliance,” or the like, as used herein refers to a computer device or computer system with program code (e.g., software or firmware) that is specifically designed to provide a specific computing resource. A “virtual appliance” is a virtual machine image to be implemented by a hypervisor-equipped device that virtualizes or emulates a computer appliance or otherwise is dedicated to provide a specific computing resource.

The term “resource” as used herein refers to a physical or virtual device, a physical or virtual component within a computing environment, and/or a physical or virtual component within a particular device, such as computer devices, mechanical devices, memory space, processor/CPU time, processor/CPU usage, processor and accelerator loads, hardware time or usage, electrical power, input/output operations, ports or network sockets, channel/link allocation, throughput, memory usage, storage, network, database and applications, workload units, and/or the like. A “hardware resource” may refer to compute, storage, and/or network resources provided by physical hardware element(s). A “virtualized resource” may refer to compute, storage, and/or network resources provided by virtualization infrastructure to an application, device, system, etc. The term “network resource” or “communication resource” may refer to resources that are accessible by computer devices/systems

via a communications network. The term “system resources” may refer to any kind of shared entities to provide services, and may include computing and/or network resources. System resources may be considered as a set of coherent functions, network data objects or services, accessible through a server where such system resources reside on a single host or multiple hosts and are clearly identifiable.

The term “channel” as used herein refers to any transmission medium, either tangible or intangible, which is used to communicate data or a data stream. The term “channel” may be synonymous with and/or equivalent to “communications channel,” “data communications channel,” “transmission channel,” “data transmission channel,” “access channel,” “data access channel,” “link,” “data link,” “carrier,” “radiofrequency carrier,” and/or any other like term denoting a pathway or medium through which data is communicated. Additionally, the term “link” as used herein refers to a connection between two devices through a RAT for the purpose of transmitting and receiving information.

The terms “instantiate,” “instantiation,” and the like as used herein refers to the creation of an instance. An “instance” also refers to a concrete occurrence of an object, which may occur, for example, during execution of program code.

The terms “coupled,” “communicatively coupled,” along with derivatives thereof are used herein. The term “coupled” may mean two or more elements are in direct physical or electrical contact with one another, may mean that two or more elements indirectly contact each other but still cooperate or interact with each other, and/or may mean that one or more other elements are coupled or connected between the elements that are said to be coupled with each other. The term “directly coupled” may mean that two or more elements are in direct contact with one another. The term “communicatively coupled” may mean that two or more elements may be in contact with one another by a means of communication including through a wire or other interconnect connection, through a wireless communication channel or link, and/or the like.

The term “information element” refers to a structural element containing one or more fields. The term “field” refers to individual contents of an information element, or a data element that contains content.

The term “SMTC” refers to an SSB-based measurement timing configuration configured by SSB-MeasurementTimingConfiguration.

The term “SSB” refers to an SS/PBCH block.

The term “a Primary Cell” refers to the MCG cell, operating on the primary frequency, in which the UE either performs the initial connection establishment procedure or initiates the connection re-establishment procedure.

The term “Primary SCG Cell” refers to the SCG cell in which the UE performs random access when performing the Reconfiguration with Sync procedure for DC operation.

The term “Secondary Cell” refers to a cell providing additional radio resources on top of a Special Cell for a UE configured with CA.

The term “Secondary Cell Group” refers to the subset of serving cells comprising the PSCell and zero or more secondary cells for a UE configured with DC.

The term “Serving Cell” refers to the primary cell for a UE in RRC_CONNECTED not configured with CA/DC there is only one serving cell comprising of the primary cell.

The term “serving cell” or “serving cells” refers to the set of cells comprising the Special Cell(s) and all secondary cells for a UE in RRC_CONNECTED configured with CA/

The term “Special Cell” refers to the PCell of the MCG or the PSCell of the SCG for DC operation; otherwise, the term “Special Cell” refers to the Pcell.

What is claimed is:

1. A method of mitigating an aggressor device, comprising:
 - identifying the aggressor device based at least in part on an original crosslink interference (CLI) measurement report from a victim device;
 - transmitting a CLI Reference Signal (CLI-RS) refinement request message to the aggressor device, wherein the CLI-RS refinement request message comprises an identifier for the aggressor device;
 - receiving a CLI-RS refinement response message from the aggressor device, wherein the CLI-RS refinement response message comprises an indication that the CLI-RS refinement request message was accepted by the aggressor device; and
 - transmitting an updated CLI measurement configuration to the victim device based at least in part on the CLI-RS refinement response message.
2. The method of claim 1, further comprising:
 - transmitting an original CLI measurement configuration to the victim device; and
 - receiving the original CLI measurement report from the victim device.
3. The method of claim 1, further comprising:
 - receiving an updated CLI measurement report from the victim device; and
 - identifying an aggressor beam of the aggressor device based at least in part on the updated CLI measurement report.
4. The method of claim 1, wherein the CLI-RS refinement response message comprises a CLI-RS transmission configuration for the aggressor device.
5. The method of claim 1, wherein the aggressor device is a user equipment (UE) or a Next Generation NodeB (gNB).
6. The method of claim 1, wherein the victim device is a user equipment (UE) or a Next Generation NodeB (gNB).
7. The method of claim 1, wherein the CLI-RS refinement request message comprises a transmission information type for the aggressor device.
8. A base station, comprising:
 - radio front end circuitry; and
 - processing circuitry coupled to the radio front end circuitry and configured to:
 - identify an aggressor device based at least in part on an original crosslink interference (CLI) measurement report from a victim device;
 - transmit, via the radio front end circuitry, a CLI Reference Signal (CLI-RS) refinement request message to the aggressor device, wherein the CLI-RS refinement request message comprises an identifier for the aggressor device;
 - receive, via the radio front end circuitry, a CLI-RS refinement response message from the aggressor device, wherein the CLI-RS refinement response message comprises an indication that the CLI-RS refinement request message was accepted by the aggressor device; and
 - transmit, via the radio front end circuitry, an updated CLI measurement configuration to the victim device based at least in part on the CLI-RS refinement response message.

59

9. The base station of claim 8, wherein the processing circuitry is further configured to:
 transmit, via the radio front end circuitry, an original CLI measurement configuration to the victim device; and
 receive, via the radio front end circuitry, the original CLI measurement report from the victim device.

10. The base station of claim 8, wherein the processing circuitry is further configured to:
 receive, via the radio front end circuitry, an updated CLI measurement report from the victim device; and
 identify an aggressor beam associated with the aggressor device based at least in part on the updated CLI measurement report.

11. The base station of claim 8, wherein the CLI-RS refinement response message comprises a CLI-RS transmission configuration for the aggressor device.

12. The base station of claim 8, wherein the aggressor device is a user equipment (UE) or a Next Generation NodeB (gNB).

13. The base station of claim 8, wherein the victim device is a user equipment (UE) or a Next Generation NodeB (gNB).

14. The base station of claim 8, wherein the CLI-RS refinement request message comprises a transmission information type for the aggressor device.

15. A non-transitory computer-readable medium having instructions stored thereon that, when executed by at least one computing device, cause the at least one computing device to perform operations comprising:

- identifying an aggressor device based at least in part on an original crosslink interference (CLI) measurement report from a victim device;
- transmitting a CLI Reference Signal (CLI-RS) refinement request message to the aggressor device, wherein the CLI-RS refinement request message comprises an identifier for the aggressor device;

60

receiving a CLI-RS refinement response message from the aggressor device, wherein the CLI-RS refinement response message comprises an indication that the CLI-RS refinement request message was accepted by the aggressor device; and

transmitting an updated CLI measurement configuration to the victim device based at least in part on the CLI-RS refinement response message.

16. The non-transitory computer-readable medium of claim 15, wherein the operations further comprise:
 transmitting an original CLI measurement configuration to the victim device; and
 receiving the original CLI measurement report from the victim device.

17. The non-transitory computer-readable medium of claim 15, wherein the operations further comprise:
 receiving an updated CLI measurement report from the victim device; and
 identifying an aggressor beam of the aggressor device based at least in part on the updated CLI measurement report.

18. The non-transitory computer-readable medium of claim 15, wherein the CLI-RS refinement response message comprises a CLI-RS transmission configuration for the aggressor device.

19. The non-transitory computer-readable medium of claim 15, wherein the aggressor device is a user equipment (UE) or a Next Generation NodeB (gNB), and the victim device is a user equipment (UE) or a Next Generation NodeB (gNB).

20. The non-transitory computer-readable medium of claim 15, wherein the CLI-RS refinement request message comprises a transmission information type for the aggressor device.

* * * * *