



(19) **United States**

(12) **Patent Application Publication**
SATISH et al.

(10) **Pub. No.: US 2019/0373013 A1**

(43) **Pub. Date: Dec. 5, 2019**

(54) **GRAPHICAL INTERFACE FOR INCIDENT RESPONSE AUTOMATION**

(71) Applicant: **Splunk Inc.**, San Francisco, CA (US)

(72) Inventors: **Sourabh SATISH**, Fremont, CA (US); **Oliver FRIEDRICHS**, Woodside, CA (US); **Atif MAHADIK**, Fremont, CA (US); **Govind SALINAS**, Sunnyvale, CA (US)

(73) Assignee: **Splunk Inc.**, San Francisco, CA (US)

(21) Appl. No.: **16/539,918**

(22) Filed: **Aug. 13, 2019**

Related U.S. Application Data

(63) Continuation of application No. 16/107,975, filed on Aug. 21, 2018, now Pat. No. 10,425,441, which is a continuation of application No. 15/699,454, filed on Sep. 8, 2017, now Pat. No. 10,158,663, which is a continuation of application No. 14/689,973, filed on Apr. 17, 2015, now Pat. No. 9,762,607.

(60) Provisional application No. 62/106,830, filed on Jan. 23, 2015, provisional application No. 62/106,837, filed on Jan. 23, 2015, provisional application No. 62/087,025, filed on Dec. 3, 2014.

Publication Classification

(51) **Int. Cl.**
H04L 29/06 (2006.01)
G06F 16/28 (2006.01)
G06F 21/55 (2006.01)
(52) **U.S. Cl.**
CPC **H04L 63/1441** (2013.01); **H04L 63/1425** (2013.01); **H04L 63/0236** (2013.01); **H04L 63/1433** (2013.01); **H04L 47/2425** (2013.01); **G06F 21/554** (2013.01); **H04L 63/1416** (2013.01); **H04L 63/20** (2013.01); **G06F 16/285** (2019.01)

(57) **ABSTRACT**

Systems, methods, and software described herein enhances how security actions are implemented within a computing environment. In one example, a method of implementing security actions for a computing environment comprising a plurality of computing assets includes identifying a security action in a command language for the computing environment. The method further provides identifying one or more computing assets related to the security action, and obtaining hardware and software characteristics for the one or more computing assets. The method also includes translating the security action in the command language to one or more action procedures based on the hardware and software characteristics, and initiating implementation of the one or more action procedures in the one or more computing assets.

100
➤

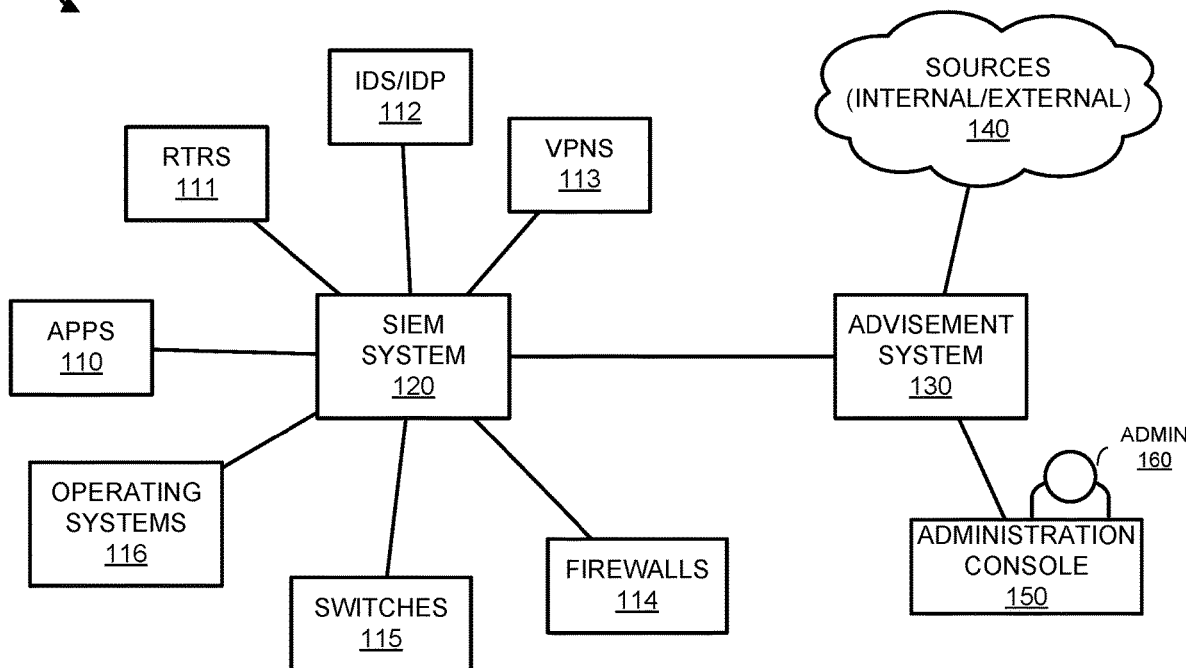

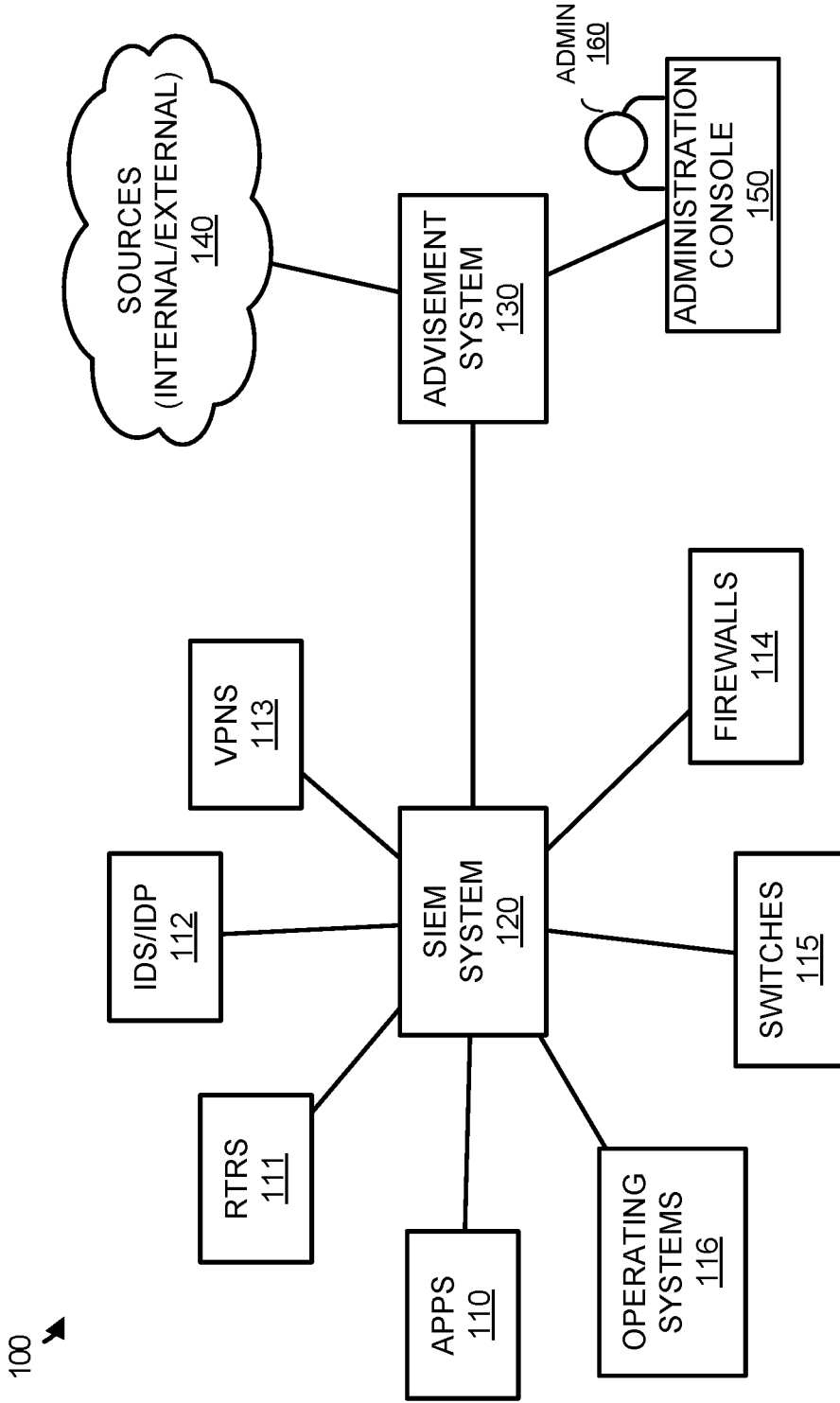

FIGURE 1

200

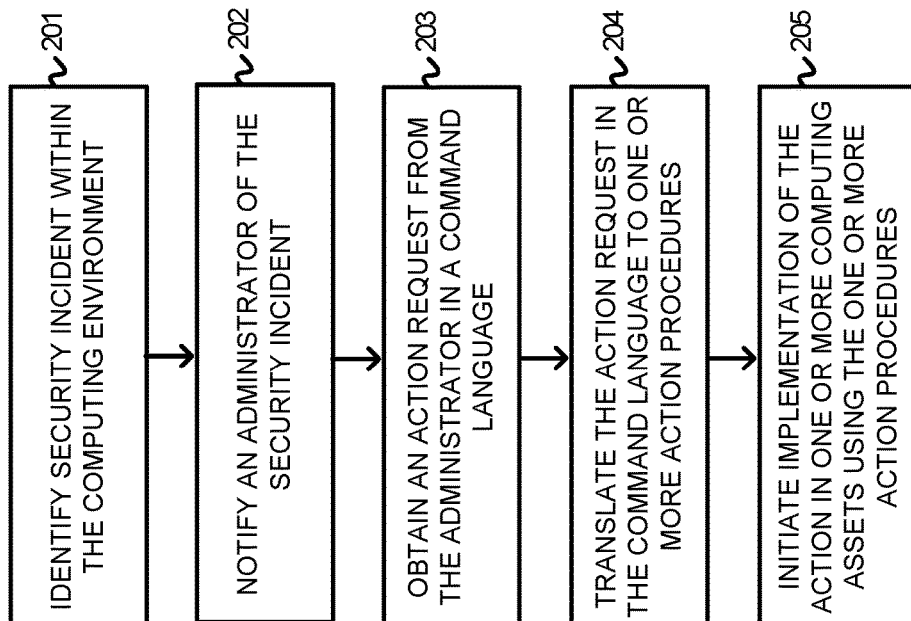

FIGURE 2

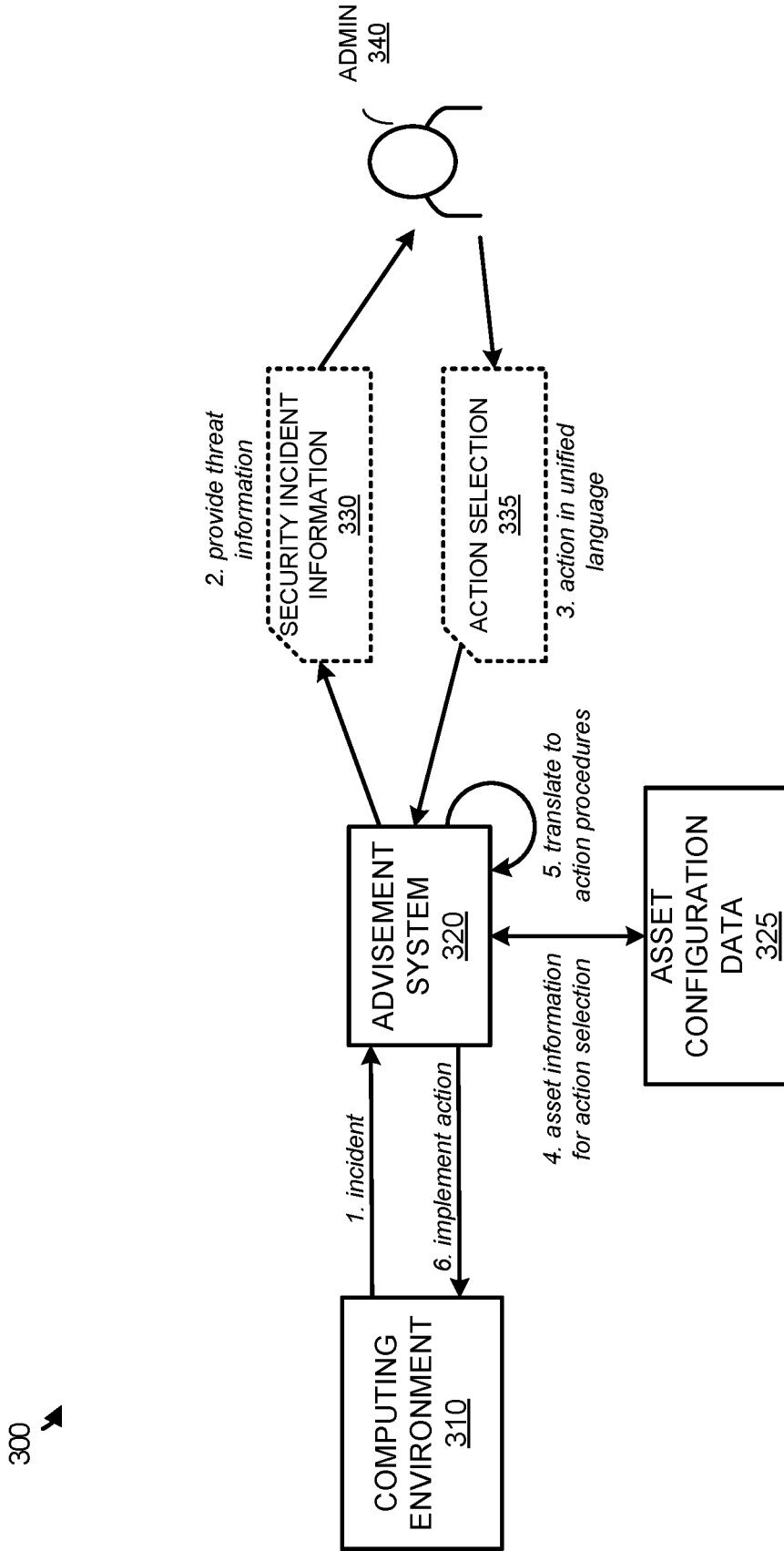

FIGURE 3

400

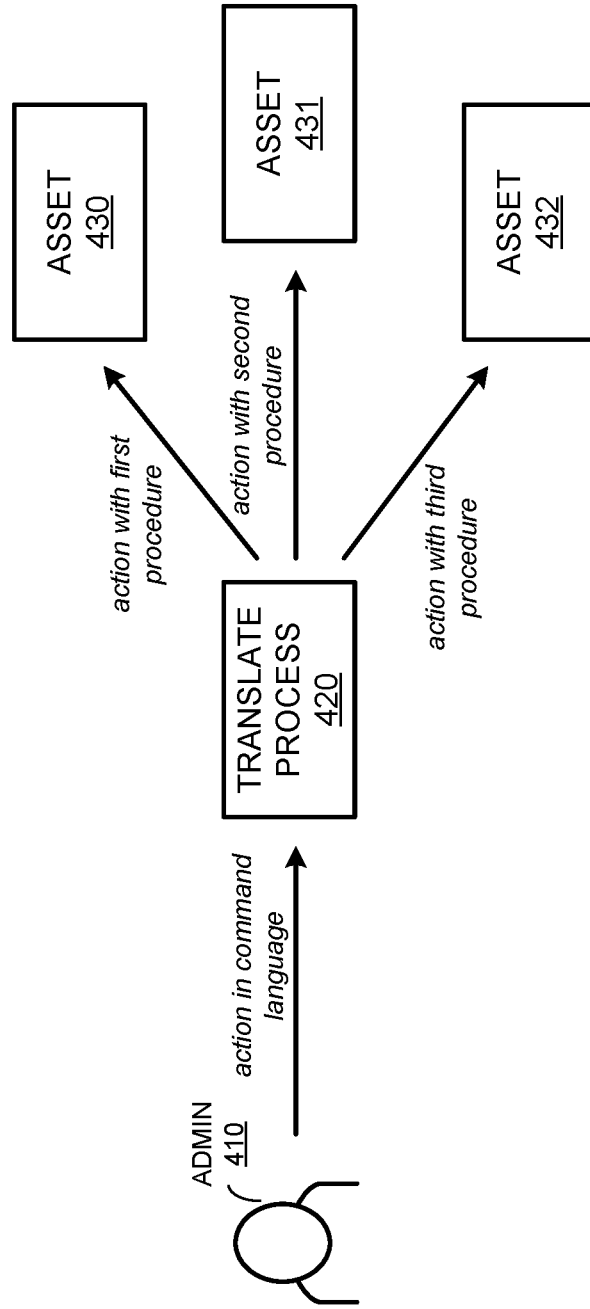

FIGURE 4

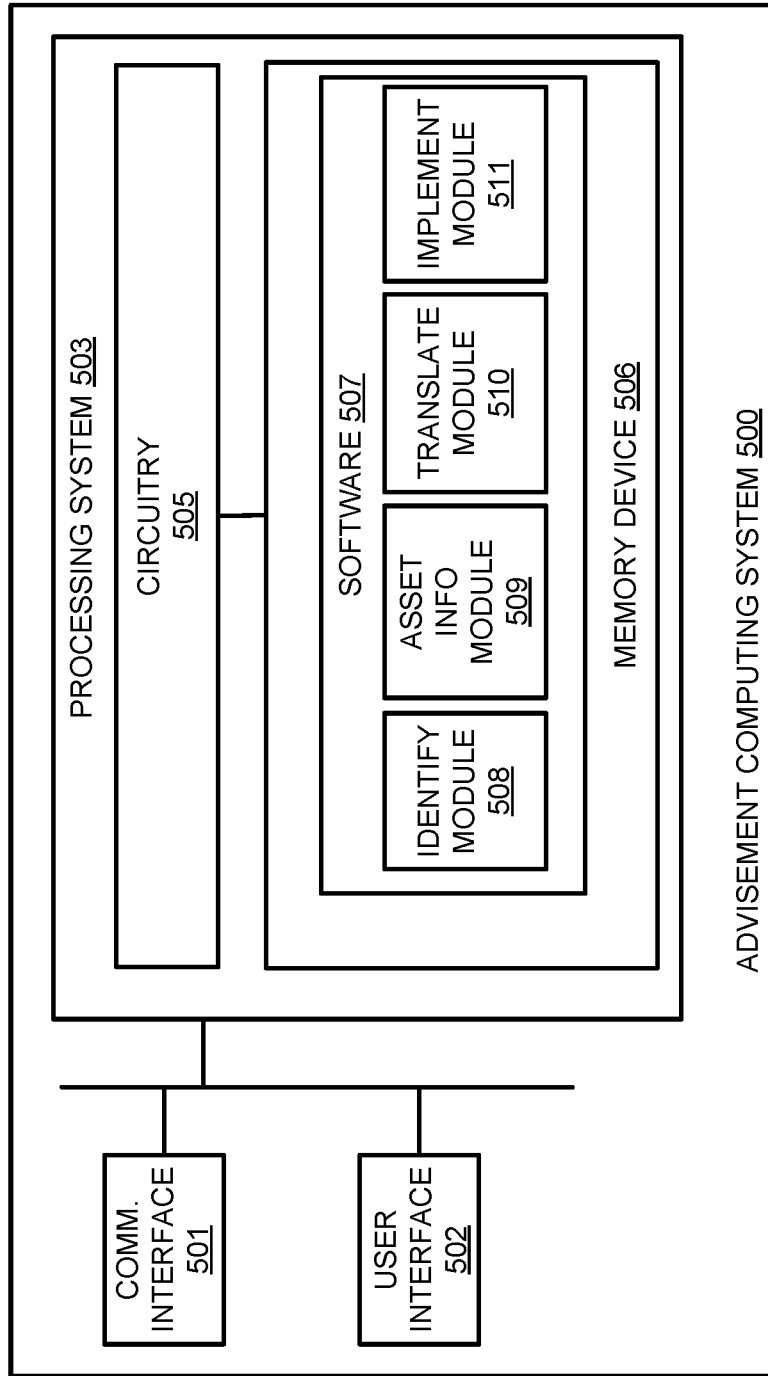

FIGURE 5

GRAPHICAL INTERFACE FOR INCIDENT RESPONSE AUTOMATION

RELATED APPLICATIONS

[0001] This application is a continuation of, and claims the benefit of priority to, U.S. patent application Ser. No. 16/107,975, filed on Aug. 21, 2018, which is a continuation of U.S. application Ser. No. 15/699,454, filed on Sep. 9, 2017, issued as U.S. Pat. No. 10,158,663, which is a continuation of U.S. application Ser. No. 14/689,973, filed on Apr. 17, 2015, entitled "INCIDENT RESPONSE AUTOMATION ENGINE," issued as U.S. Pat. No. 9,762,607, which itself claims priority to U.S. Provisional Patent Application No. 62/087,025, entitled "ACTION RECOMMENDATIONS FOR COMPUTING ASSETS BASED ON ENRICHMENT INFORMATION," filed on Dec. 3, 2014, U.S. Provisional Patent Application No. 62/106,830, entitled "ACTION RECOMMENDATIONS FOR ADMINISTRATORS IN A COMPUTING ENVIRONMENT," filed on Jan. 23, 2015, and U.S. Provisional Patent Application No. 62/106,837, entitled "SECURITY ACTIONS IN A COMPUTING ENVIRONMENT," filed on Jan. 23, 2015, all of which are hereby incorporated by reference in their entirety.

TECHNICAL FIELD

[0002] Aspects of the disclosure are related to computing environment security, and in particular to managing the allocation of security actions to computing assets with various configurations.

TECHNICAL BACKGROUND

[0003] An increasing number of data security threats exist in the modern computerized society. These threats may include viruses or other malware that attacks the local computer of the end user, or sophisticated cyber attacks to gather data and other information from the cloud or server based infrastructure. This server based infrastructure includes real and virtual computing devices that are used to provide a variety of services to user computing systems, such as data storage, cloud processing, web sites and services, amongst other possible services. To protect applications and services, various antivirus, encryption, and firewall implementations may be used across an array of operating systems, such as Linux and Microsoft Windows.

[0004] Further, some computing environments may implement security information and event management (SIEM) systems and other security detection systems to provide analysis of security alerts generated by network hardware and applications. In particular, SIEM systems allow for real-time monitoring, correlation of events, notifications, and console views for end users. Further, SIEM systems may provide storage logs capable of managing historical information about various security events within the network. Although SIEMs and other security threat identifying systems may generate security alerts for devices within the network, administrators may be forced to translate each of these alerts into particular actions, which take time and resources.

OVERVIEW

[0005] The technology disclosed herein enhances how security actions are implemented within a computing environment. In one example, a method of implementing secu-

urity actions for a computing environment comprising a plurality of computing assets includes identifying a security action in a command language for the computing environment. The method further provides identifying one or more computing assets related to the security action, and obtaining hardware and software characteristics for the one or more computing assets. The method also includes translating the security action in the command language to one or more action procedures based on the hardware and software characteristics, and initiating implementation of the one or more action procedures in the one or more computing assets.

BRIEF DESCRIPTION OF THE DRAWINGS

[0006] Many aspects of the disclosure can be better understood with reference to the following drawings. While several implementations are described in connection with these drawings, the disclosure is not limited to the implementations disclosed herein. On the contrary, the intent is to cover all alternatives, modifications, and equivalents.

[0007] FIG. 1 illustrates a computing environment to manage security actions for a plurality of network assets.

[0008] FIG. 2 illustrates a method of operating an advisement system to implement security actions.

[0009] FIG. 3 illustrates an operational scenario of implementing security actions in a computing environment.

[0010] FIG. 4 illustrates a flow diagram of implementing a security action in multiple computing assets.

[0011] FIG. 5 illustrates an advisement computing system to implement security actions in a computing environment.

TECHNICAL DISCLOSURE

[0012] The various examples disclosed herein provide enhancements for implementing security actions in computing assets with various hardware and software configurations. In many organizations, security systems, such as security information and event management (SIEM) systems provide analysis of security alerts generated by network hardware and processes. The network hardware and processes may include routers, firewalls, operating systems and applications executing on one or more computing devices, switches, or intrusion detection systems, amongst a variety of other network devices and processes. During the analysis of the particular network, a SIEM system may identify an issue, and flag the issue as a possible security threat. Once flagged, the SIEM system may provide information to an administrator, or store information about the threat to be analyzed for a possible solution.

[0013] Here, in addition to the operations provided by the SIEM system or other security monitoring systems within a computing environment, an advisement system may be used to identify, implement, and recommend security actions to be taken against security threats. In particular, the advisement system may generate actions to be implemented in computing assets with varying software and hardware configurations. For example, a first computing asset may include a firewall from a first software distributor, while a second computing asset within the same environment may include a firewall from a second software distributor. Accordingly, to implement a security action within the first and second computing assets, the advisement system might be required to use multiple command procedures, which are specific to the firewalls on the individual computing assets.

[0014] In some implementations, the advisement system may allow administrators to provide actions in a unified command language that can be translated as necessary into the various procedures necessary for the computing assets in the environment. Consequently, rather than developing commands in each of the command languages necessary for the various assets in the environment, an administrator may use a single language for all of the assets in the environment. Referring to a firewall implementation, if an internet protocol (IP) address is to be blocked on multiple computing devices, the unified language could specify the IP address and the computing assets for the action implementation. Once specified, the command may be translated into the necessary sets of procedures to implement the IP block on the computing systems.

[0015] In some examples, the unified language for the computing environment may include various characters and symbols. However, in other implementations, the administrator may use a visual programming language to specify particular security actions. This visual programming language may include visual representations of computing assets, visual representations of communication interactions with the computing assets, or any other similar visual representation. For example, the user may select visual representations of two computing assets, and specify, via links or other symbols, that the assets should no longer communicate with one another. In some implementations, to prevent future communications the administrator may draw or connect a link on a user interface that represents a blocked communication between the two assets. However, it should be understood that to prevent future communications the user might provide a written command to implement the same action.

[0016] To further illustrate the operation of an advisement system within a computing network, FIG. 1 is provided. FIG. 1 illustrates a computing environment 100 to manage security actions for a plurality of network assets. Computing environment 100 includes computing assets 110-116, STEM system 120, advisement system 130, sources 140, and administration console 150. Computing assets 110-116 include applications 110, routers 111, intrusion detection systems and intrusion prevention system (IDS/IDP) 112, virtual private networks (VPNs) 113, firewalls 114, switches 115, and operating systems 116, although other assets may exist. Assets 110-116 may execute via any number of computing systems or devices. In addition to the routers and switches, these computing devices may include server computers, desktop computers, laptop computers, tablet computers, and the like. Although not illustrated in the present example, in some implementations, assets may be defined at computing system level. Accordingly, assets may be defined as physical computing systems, such as servers, end user computing systems, host computing systems, and the like, and may further be defined as virtual processing systems, such as virtual machines or containers executing via host computing systems. These physical and virtual computing systems may include an operating system, applications, processes, firewalls, and other similar computing resources.

[0017] SIEM system 120, advisement system 130, internal and external sources 140, and administration console 150 may each include communication interfaces, network interfaces, processing systems, computer systems, microprocessors, storage systems, storage media, or some other processing devices or software systems, and can be distributed

among multiple devices. STEM system 120, advisement system 130, and sources 140 may comprise one or more server, desktop, laptop, or other similar computing devices. Administration console 150 may comprise an end user device, such as a desktop computer, laptop computer, smart-phone, tablet, or any other similar computing device.

[0018] Advisement system 130 communicates with STEM system 120, sources 140, and administration console 150 via communication links that may use Time Division Multiplex (TDM), asynchronous transfer mode (ATM), internet protocol (IP), Ethernet, synchronous optical networking (SONET), hybrid fiber-coax (HFC), circuit-switched communication signaling, wireless communications, or some other communication format, including combinations and improvements thereof. Similarly, STEM system 120 may gather information from assets 110-116 via a plurality of communication links to the computing systems associated with the assets, wherein the links may use TDM, ATM, IP, Ethernet, SONET, HFC, circuit-switched communication signaling, wireless communications, or some other communication format, including combinations and improvements thereof. While not illustrated in the present example, it should be understood that advisement system 130 might communicate with the assets over various communication links and communication formats to implement desired security actions.

[0019] In operation, SIEM system 120 receives data and performance information from assets 110-116 and performs inspections to identify possible security issues. Once STEM system 120 identifies a possible security threat, information about the security threat is transferred to advisement system 130. Advisement system 130 identifies the security threat and analyzes the threat using sources 140 to determine actions against the security threat. These actions might include default actions that can be initiated and implemented within the environment without interaction from an administrator, and might further include suggested actions that can be provided to administrator (admin) 160. Once the suggested actions are determined, the suggested actions are transferred, via email, text message, or other similar format, to administration console 150 to be presented to administrator 160. From the suggested actions, administrator 160 may select a particular action and advisement system 130 may implement the action within the computing environment.

[0020] In some implementations, to select a particular action, the administrator may use a unified security language to implement actions in a variety of hardware and software configurations. Once the administrator enters a command using the unified language, the language may be translated into the one or more processes or languages necessary to implement the action within the computing environment. For example, the administrator may select to remove a particular malicious process from multiple computing systems with different software configurations. Accordingly, advisement system 130 may be used to translate the command from the administrator into the necessary processes to remove each instance of the malicious process on the varying computing systems.

[0021] Referring now to FIG. 2 to further demonstrate the operation of advisement system 130. FIG. 2 illustrates a method 200 of operating advisement system 130 to implement security actions. As described above in FIG. 1, STEM system 120 receives information from a plurality of network

assets **110-116** and identifies security threats to devices and systems based on the information. Once a threat is recognized, information about the threat is transferred to, and identified by, advisement system **130** (**201**). In response to identifying the threat, advisement system **130** notifies administrator **160** of the security incident (**202**). In some implementations, to notify administrator **160**, advisement system **130** may provide information about the security threat, including the asset associated with the threat, the IP address associated with the threat, the severity level of the threat, the number of assets affected by the threat, or other similar information. This information may be gathered from STEM system **120**, may be gathered from the assets within computing environment **100**, or may be gathered from internal and external sources **140** related to the particular incident. For example, enrichment information may be gathered from a web database regarding an unknown process executing on a computing system. In addition to or in place of the information about the threat, advisement system **130** may further provide action recommendations to administrator **160** based on gathered enrichment information. These action recommendations may include separating the affected asset from the other assets within the environment, removing a particular threat from a computing asset, blocking one or more IP addresses related to a threat, or any other similar action to protect the assets in computing environment **100**.

[0022] Once the information is provided to administrator **160**, advisement system **130** may obtain an action request from administrator **160** in a command language (**203**). As illustrated in FIG. 1, advisement system **130** may provide information to administration console **150** via a web based console, a text message, an email, or some other similar form of communication. In response to receiving the information about the threat, administrator **160** may use a command language to implement a security modification to counter the security threat. For example, the user may select to block a particular IP address from communicating with one or more assets within the environment.

[0023] Upon identifying the action request from administrator **160**, advisement system **130** translates the action request in the command language to one or more action procedures (**204**). To translate the command, advisement system **130** may identify the hardware and software configurations for the assets associated with the action request. For example, the administrator may request that an IP address is blocked in a firewall for two computing systems. In response to the request, advisement system **130** may identify the hardware and software configurations for the two computing systems, and translate the action into procedures required by the two computing systems. Once the command is translated, advisement system **130** may initiate implementation of the action in the required computing assets using the one or more identified procedures (**205**).

[0024] In some examples, to implement the actions within each of the computing assets, procedures may need to be executed with indefinite time delays. For instance, to implement a firewall action within the computing environment, advisement system **130** may be required to log into the computing asset, and transfer one or more commands to the computing asset to block the required address. Accordingly, advisement system **130** may be configured to wait until each process is completed, such as waiting to be logged into the computing asset before applying the procedures necessary to block the IP address.

[0025] Although illustrated in FIG. 1 with a SIEM system, it should be understood that in some examples, other systems, such as the assets themselves within the computing environment, might be used to identify security threats. Further, although illustrated separate in the example of FIG. 1, it should be understood that SIEM system **120** might reside wholly or partially on the same computing systems as advisement system **130**.

[0026] Turning to FIG. 3, FIG. 3 illustrates an operational scenario **300** of implementing security actions in a computing environment according to one implementation. Operational scenario **300** includes computing environment **310**, advisement system **320**, asset configuration data **325**, security incident information **330**, action selection **335**, and administrator (admin) **340**. Computing environment **310** includes a plurality of computing assets, which may comprise end user computing systems, routers, switches, firewalls, or any other similar computing asset.

[0027] As illustrated in FIG. 3, advisement system **320** initially identifies a security incident within computing environment **310**. This security incident may be identified from one of the computing assets directly, or may be identified by a security monitoring system, such as STEM systems that monitor security threats within the various computing assets. Once the incident is identified by advisement system **320**, advisement system **320** may provide security incident information **330** to administrator **340**. In some implementations, security incident information **330** may be provided via a user interface on advisement system **320**. However, in other instances, security incident information **330** may be provided as a text message, email correspondence, web view, or other similar interface at an administration console for administrator **340**. Security incident information **330** may include information about the asset affected by the threat, an IP address related to the source of the threat, information about a process related to the threat, a severity level of the threat, or some other similar information. This information may be obtained directly from the assets and security management systems, and may further be supplemented with enrichment information gathered from internal and external sources. For example, if an unknown process were identified on one of the computing assets, advisement system **320** may query a database to identify whether the process was malicious. Once the inquiry is made, the information returned from the database may be provided in security incident information **330**. In some implementations, in addition to or in place of the information gathered about the threat, advisement system **320** may determine suggested actions that can be provided to administrator **340**. These suggested actions may include removing a particular malicious process, entering one or more computing assets into virtual local area network (VLAN), blocking particular IP addresses, or some other similar action recommendation based on the threat and possible enrichment information.

[0028] Once security incident information **330** is provided to administrator **340**, administrator **340** may generate action selection **335**. Here, action selection **335** comprises a selection made in a unified command language for all assets within the environment. Once action selection **335** is identified by advisement system **320**, advisement system **320** may obtain hardware and software configuration information based on the action selection. For example, action selection **335** may include a request to remove a particular

process from multiple computing assets within computing environment 310. In response to the request, advisement system 320 may use asset configuration data 325 to determine software and hardware characteristics for the relevant computing assets. Once the characteristics are obtained, advisement system 320 may translate action selection 335 into one or more action procedures that correspond to the software and hardware configurations of the assets.

[0029] Returning to the example of removing a particular process from multiple computing assets, each of the computing assets may have a different hardware or software configuration. As a result, the procedures necessary to implement the action may be different for each of the assets. Rather than requiring administrator 340 to provide procedural commands for each of the computing assets, advisement system 320 may be used to translate an action selection into the commands for the various asset configurations. Upon translating action selection 335 into the required procedures, advisement system 320 may implement the action on the corresponding assets in computing environment 310.

[0030] In some examples, the procedures to implement a particular action within an asset may have indefinite time delays between each step of the procedure. For instance, to implement a firewall modification, advisement system 320 may be required to login to the relevant asset before providing commands to the asset. Accordingly, advisement system 320 may implement wait conditions that allow each step of the action procedures to be implemented without further interaction from the administrator.

[0031] Turning to FIG. 4, FIG. 4 illustrates a flow diagram 400 of implementing a security action in multiple computing assets. Flow diagram 400 includes administrator 410, translate process 420, and assets 430-432. Translate process 420 is representative of a process to be implemented on advisement system 130 or advisement system 320, although translate process 420 may be implemented on other computing systems. Assets 430-432 are representative of any computing asset within a computing environment, including end user computing systems, server computing systems, routers, switches, firewalls, virtual computing elements, or any other similar asset.

[0032] As described herein, computing environments include a plurality of computing assets that may encounter security incidents. To respond to the incidents, an advisement system may provide information about the threats or incidents to administrator 410, allowing the administrator to implement an action against the threat. This information may be obtained from the individual assets, from security monitoring systems within the environment, or may be supplemented with enrichment information obtained from one or more internal or external sources. The information provided to administrator 410 may include identifiers for the assets related to the incident, IP addresses related to the incident, files or processes related to the incident, indications of the severity of the incident within the environment, or any other similar information.

[0033] Once the information is provided to administrator 410, the administrator may select an action to be taken against the threat within the environment. In particular, the administrator may use a unified command language that can be used to implement security actions across a plurality of assets within the environment, including assets with different software and/or hardware configurations. For example,

the unified command language may include a structure for implementing actions within the environment, including asset identifiers for assets that require the modification, as well as one or more commands to be applied to the assets that require the modification.

[0034] Once the administrator inputs the particular action selection via a user interface on the advisement system or a separate administration console device, the advisement system identifies the action in the unified command language and translates the action to one or more action procedures based on the asset configurations. In particular, the advisement system may obtain software and hardware characteristics for each of the computing assets involved in the security action. Once the characteristics are obtained, the advisement system may translate the user generated action into the necessary procedures for the various computing assets. As depicted in FIG. 4, the action generated by administrator 410 requested modifications to assets 430-432. Accordingly, translate process 420 translates the request from the administrator in the unified language into the required procedures for assets 430-432. In the present example, each of assets 430-432 require a different set of procedures, which may occur as a result of different software or hardware configurations on the computing assets. For example, if administrator 410 desired a firewall implementation in assets 430-432, translate process 420 may translate the action into the necessary parameters and procedures for each individual firewall for the computing assets.

[0035] In some implementations, the advisement system for a computing environment may have access to a database of connectors or software modules that can be used to translate the various commands from the administrator. For example, when firewall software is distributed, a connector may be generated for the firewall that allows commands in the unified language to modify a configuration of the firewall. Accordingly, when a command is generated for an asset with the new firewall distribution, the new connector may be used to implement the required procedures.

[0036] Turning to FIG. 5, FIG. 5 illustrates an advisement computing system 500 to provide action recommendations for a plurality of network assets. Advisement computing system 500 is representative of a computing system that may be employed in any computing apparatus, system, or device, or collections thereof, to suitably implement the advisement systems described herein. Computing system 500 comprises communication interface 501, user interface 502, and processing system 503. Processing system 503 is communicatively linked to communication interface 501 and user interface 502. Processing system 503 includes processing circuitry 505 and memory device 506 that stores operating software 507.

[0037] Communication interface 501 comprises components that communicate over communication links, such as network cards, ports, radio frequency (RF) transceivers, processing circuitry and software, or some other communication devices. Communication interface 501 may be configured to communicate over metallic, wireless, or optical links. Communication interface 501 may be configured to use TDM, IP, Ethernet, optical networking, wireless protocols, communication signaling, or some other communication format—including combinations thereof. In particular, communication interface 501 may communicate with security identification systems, such as STEM systems, security monitoring processes on the assets themselves, or some

other security identification system. Further, communication interface **501** may be configured to communicate with one or more administration consoles to provide the suggested actions to administrators, and may also communicate with the computing assets of the environment to implement selected actions.

[0038] User interface **502** comprises components that interact with a user. User interface **502** may include a keyboard, display screen, mouse, touch pad, or some other user input/output apparatus. User interface **502** may be omitted in some examples.

[0039] Processing circuitry **505** comprises microprocessor and other circuitry that retrieves and executes operating software **507** from memory device **506**. Memory device **506** comprises a non-transitory storage medium, such as a disk drive, flash drive, data storage circuitry, or some other memory apparatus. Operating software **507** comprises computer programs, firmware, or some other form of machine-readable processing instructions. Operating software **507** includes identify module **508**, asset information (info) module **509**, translate module **510**, and implement module **511**, although any number of software modules may provide the same operation. Operating software **507** may further include an operating system, utilities, drivers, network interfaces, applications, or some other type of software. When executed by circuitry **505**, operating software **507** directs processing system **503** to operate advisement computing system **500** as described herein.

[0040] In particular, identify module **508** directs processing system **503** to identify a security action in a command language for the computing environment. In response to the security action, asset info module **509** directs processing system **503** to identify one or more computing assets related to the security action, and obtain hardware and software characteristics for the one or more computing assets. Based on the hardware and software characteristics, translate module **510** directs processing system **503** to translate the security action in the command language to one or more action procedures based on the hardware and software characteristics. For example, a computing environment may include a variety of different hardware with a variety of different software configurations. Accordingly, if the security action comprised an action to be implemented across multiple devices, different procedures may be required for each of the devices. Rather than requiring an administrator to manually implement the various procedures, computing system **500** may be used to translate a security action to the required procedures for various software and hardware configurations. Once the security action is translated, implement module **511** directs processing system **503** to initiate implementation of the one or more action procedures in the one or more computing assets.

[0041] In some implementations, advisement computing system **500** may have access to one or more connectors or modules that can be used to interface with the various hardware and software within the computing environment. For example, a security action from an administrator may select to implement a firewall to be applied across multiple computing assets with multiple hardware and/or software configurations. In response to identifying the action, computing system **500** may identify hardware and software characteristics for the computing assets that require the modification, and translate the action based on the characteristics. For example, a first connector may specify the

action procedures for a computing system with a first firewall distribution, whereas a second connector may specify the action procedures for a computing system with a second firewall distribution.

[0042] Although not illustrated in the present example, in some instances, advisement computing system **500** may be configured to notify an administrator of a security threat within the environment. This notification may include the identity of the asset affected by the threat, the severity of the threat within the environment, the IP address associated with the threat, the process name associated with the threat, or any other similar information. The information may be obtained directly from the assets in the environment, a security system configured to monitor for security issues within the environment, or may be obtained from internal and external sources. For example, computing system **500** may identify a security issue within the computing environment. In response to the security issue, processing system **503** may be configured to query internal and external sources for enrichment data regarding the threat. Accordingly, if an unknown process were identified as executing on a computing asset, processing system **503** may query a database to determine if the process is malicious. Once the information is retrieved, the information may be provided to the administrator with the notification, allowing the administrator to generate a security action in the environment.

[0043] The included descriptions and figures depict specific implementations to teach those skilled in the art how to make and use the best option. For the purpose of teaching inventive principles, some conventional aspects have been simplified or omitted. Those skilled in the art will appreciate variations from these implementations that fall within the scope of the invention. Those skilled in the art will also appreciate that the features described above can be combined in various ways to form multiple implementations. As a result, the invention is not limited to the specific implementations described above, but only by the claims and their equivalents.

What is claimed is:

1. A computer-implemented method comprising:
 - providing, to an administrator, information related to a security incident associated with a computing environment comprising a plurality of computing assets;
 - causing display of a graphical user interface (GUI) including a visual representation of at least a portion of the computing environment;
 - receiving, via the GUI, input requesting implementation of a security action related to the security incident, wherein the security action is to be implemented at one or more computing assets of the plurality of computing assets, and wherein the security action is part of a command language of security actions;
 - translating the security action into one or more action procedures to be implemented at each of the one or more computing assets of the plurality of computing assets; and
 - initiating implementation of the one or more action procedures at each of the one or more computing assets of the plurality of computing assets.
2. The computer-implemented method of claim 1, wherein the plurality of computing assets include at least one of: a host computing system, an end user computing system, a router, a switch, or a virtual processing system.

3. The computer-implemented method of claim 1, wherein translating the security action into one or more actions procedures includes translating the security action into one or more first action procedures to be implemented at a first computing asset of the plurality of computing assets and into one or more second action procedures to be implemented at a second computing asset of the plurality of computing assets, wherein the first action procedures are different from the second action procedures.

4. The computer-implemented method of claim 1, wherein implementation of the security action includes at least one of: blocking an internet protocol (IP) address, ending a process on the one or more computing assets, or adding the one or more computing assets into a virtual local area network (VLAN).

5. The computer-implemented method of claim 1, wherein the visual representation of at least a portion of the computing environment includes a visual representation of at least one computing asset of the plurality of computing assets.

6. The computer-implemented method of claim 1, wherein the security incident is identified based on information generated by a security detection system that monitors the plurality of computing assets.

7. The computer-implemented method of claim 1, wherein the information related to the security incident includes at least one of: information about a computing asset affected by the security incident, an internet protocol (IP) address related to a source of the security incident, a process related to the security incident, and a severity level of the security incident.

8. The computer-implemented method of claim 1, further comprising obtaining enrichment information for the security incident from one or more internal or external sources.

9. The method of claim 1, wherein the information related to the security incident further comprises at least one suggested security action.

10. The computer-implemented method of claim 1, wherein initiating implementation of the one or more action procedures comprises initiating implementation of the one or more action procedures in a relative order.

11. The computer-implemented method of claim 1, wherein the information related to the security incident further comprises at least one suggested security action, and wherein the method further comprises causing display of a visual representation of the at least one suggested security action in association with the visual representation of at least a portion of the computing environment.

12. The computer-implemented method of claim 1, wherein the information related to the security incident includes asset identifiers for computing assets related to the security incident.

13. The computer-implemented method of claim 1, wherein the information related to the security incident includes enrichment information for the security incident obtained from internal or external sources.

14. The computer-implemented method of claim 1, further comprising obtaining enrichment information related to the security incident from one or more internal or external sources, wherein the security action is translated into the one or more action procedures based at least in part on the enrichment information.

15. The computer-implemented method of claim 1, obtaining enrichment information related to the security

incident from one or more internal or external sources, the enrichment information including at least one of: information indicating whether a process or file is malicious, or information indicating whether an internet protocol (IP) address is malicious.

16. The computer-implemented method of claim 1, wherein the security incident includes at least one of: a virus, malware, or a network-based attack.

17. The computer-implemented method of claim 1, wherein the input requesting implementation of the security action includes using the visual representation of at least a portion of the computing environment to draw a connection between at least two computing assets of the plurality of computing assets.

18. The computer-implemented method of claim 1, wherein the visual representation of at least a portion of the computing environment includes a visual representation of communication interactions between at least two computing assets of the plurality of computing assets.

19. The computer-implemented method of claim 1, wherein the information related to the security incident is provided to the administrator via at least one of: an application console, a web-based console, an email, or a text message.

20. The computer-implemented method of claim 1, further comprising obtaining configuration information associated with each of the one or more computing assets of the plurality of computing assets, wherein translating the security action into one or more actions procedures is based at least in part on the configuration information.

21. The computer-implemented method of claim 1, wherein the one or more action procedures include at least two action procedures to be performed in a defined sequence.

22. The computer-implemented method of claim 1, further comprising receiving an indication of the security incident from a security information and event management (SIEM) system.

23. A non-transitory computer-readable storage medium storing instructions which, when executed by one or more processors, cause performance of operations comprising:

providing, to an administrator, information related to a security incident associated with a computing environment comprising a plurality of computing assets;

causing display of a graphical user interface (GUI) including a visual representation of at least a portion of the computing environment;

receiving, via the GUI, input requesting implementation of a security action related to the security incident, wherein the security action is to be implemented at one or more computing assets of the plurality of computing assets, and wherein the security action is part of a command language of security actions;

translating the security action into one or more action procedures to be implemented at each of the one or more computing assets of the plurality of computing assets; and

initiating implementation of the one or more action procedures at each of the one or more computing assets of the plurality of computing assets.

24. The non-transitory computer-readable storage medium of claim 23, wherein the plurality of computing

assets include at least one of: a host computing system, an end user computing system, a router, a switch, or a virtual processing system.

25. The non-transitory computer-readable storage medium of claim **23**, wherein translating the security action into one or more actions procedures includes translating the security action into one or more first action procedures to be implemented at a first computing asset of the plurality of computing assets and into one or more second action procedures to be implemented at a second computing asset of the plurality of computing assets, wherein the first action procedures are different from the second action procedures.

26. The non-transitory computer-readable storage medium of claim **23**, wherein implementation of the security action includes at least one of: blocking an internet protocol (IP) address, ending a process on the one or more computing assets, or adding the one or more computing assets into a virtual local area network (VLAN).

27. An apparatus, comprising:

one or more processors;

a non-transitory computer-readable storage medium storing instructions which, when executed by the one or more processors, causes the apparatus to:

provide, to an administrator, information related to a security incident associated with a computing environment comprising a plurality of computing assets; cause display of a graphical user interface (GUI) including a visual representation of at least a portion of the computing environment;

receive, via the GUI, input requesting implementation of a security action related to the security incident, wherein the security action is to be implemented at

one or more computing assets of the plurality of computing assets, and wherein the security action is part of a command language of security actions;

translate the security action into one or more action procedures to be implemented at each of the one or more computing assets of the plurality of computing assets; and

initiate implementation of the one or more action procedures at each of the one or more computing assets of the plurality of computing assets.

28. The apparatus of claim **27**, wherein the plurality of computing assets include at least one of: a host computing system, an end user computing system, a router, a switch, or a virtual processing system.

29. The apparatus of claim **27**, wherein translating the security action into one or more actions procedures includes translating the security action into one or more first action procedures to be implemented at a first computing asset of the plurality of computing assets and into one or more second action procedures to be implemented at a second computing asset of the plurality of computing assets, wherein the first action procedures are different from the second action procedures.

30. The apparatus of claim **27**, wherein implementation of the security action includes at least one of: blocking an internet protocol (IP) address, ending a process on the one or more computing assets, or adding the one or more computing assets into a virtual local area network (VLAN).

* * * * *