



US 20200386289A1

(19) **United States**

(12) **Patent Application Publication**
Clymer et al.

(10) **Pub. No.: US 2020/0386289 A1**

(43) **Pub. Date: Dec. 10, 2020**

(54) **MAGNETICALLY-COUPLED
TORQUE-ASSIST APPARATUS**

(52) **U.S. Cl.**
CPC *F16F 6/005* (2013.01); *F16F 2222/06*
(2013.01); *H02K 49/108* (2013.01)

(71) Applicant: **GREEN WAVE POWER SYSTEMS
LLC**, Haddam, CT (US)

(72) Inventors: **Mark Lawrence Clymer**, Moodus, CT
(US); **Brenda Lee McConnell**,
Moodus, CT (US)

(57) **ABSTRACT**

(21) Appl. No.: **16/923,915**

(22) Filed: **Jul. 8, 2020**

Related U.S. Application Data

(63) Continuation-in-part of application No. 16/738,352,
filed on Jan. 9, 2020.

(60) Provisional application No. 62/917,939, filed on Jan.
9, 2019, provisional application No. 62/872,030, filed
on Jul. 9, 2019.

Publication Classification

(51) **Int. Cl.**
F16F 6/00 (2006.01)
H02K 49/10 (2006.01)

A magnetically-coupled torque assist apparatus includes a movable (rotor) magnet configured to rotate about a rotor magnet axis extending through the rotor magnet, and a stationary (stator) magnet. The rotor magnet and the stator magnet have a gap therebetween. There is an equilibrium state position (ESP) of the rotor magnet where forces acting on the rotor magnet are balanced such that the rotor magnet is stationary about the rotor magnet axis. And when the rotor magnet is rotated from the equilibrium state position (ESP) to an elastically stressed state position (SSP), magnetic fields of the rotor magnet and the stator magnet generate a resultant magnetic force on the movable magnet that biases the movable magnet towards the equilibrium state position. In some embodiments, the stator and rotor magnets are configured to create a Halbach-effect magnetic field bloom, which contributes to the magnetic forces.

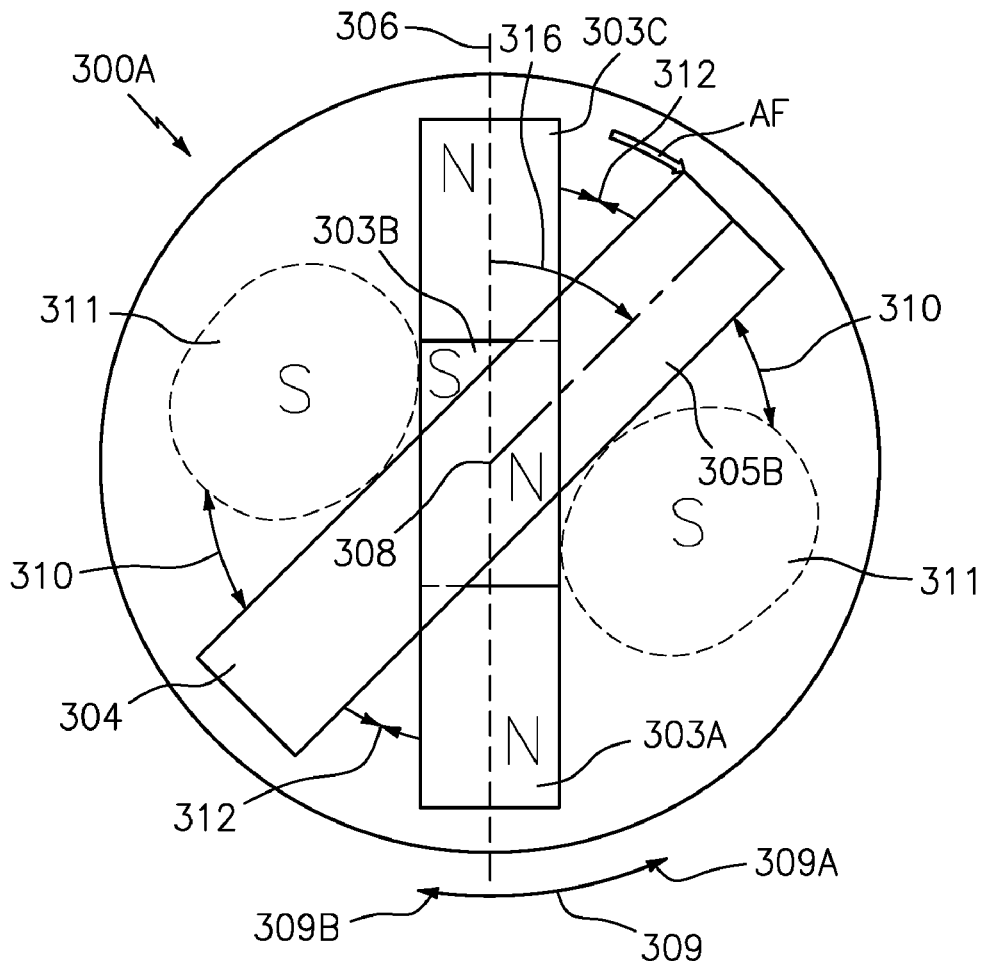

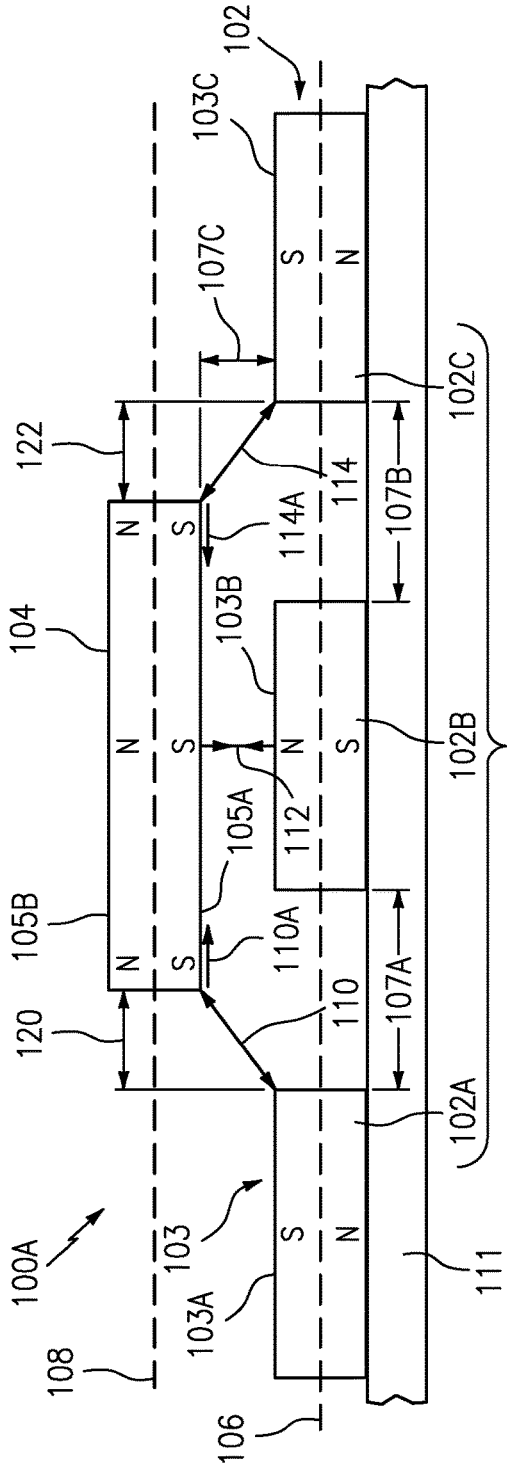

FIG. 1A

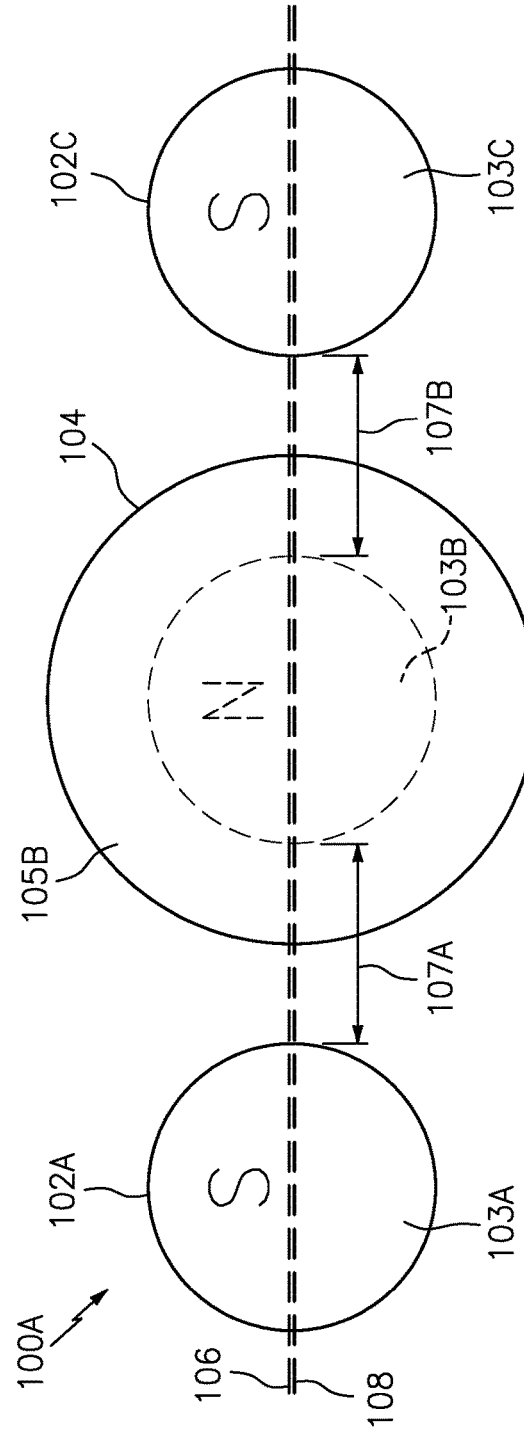

FIG. 1B

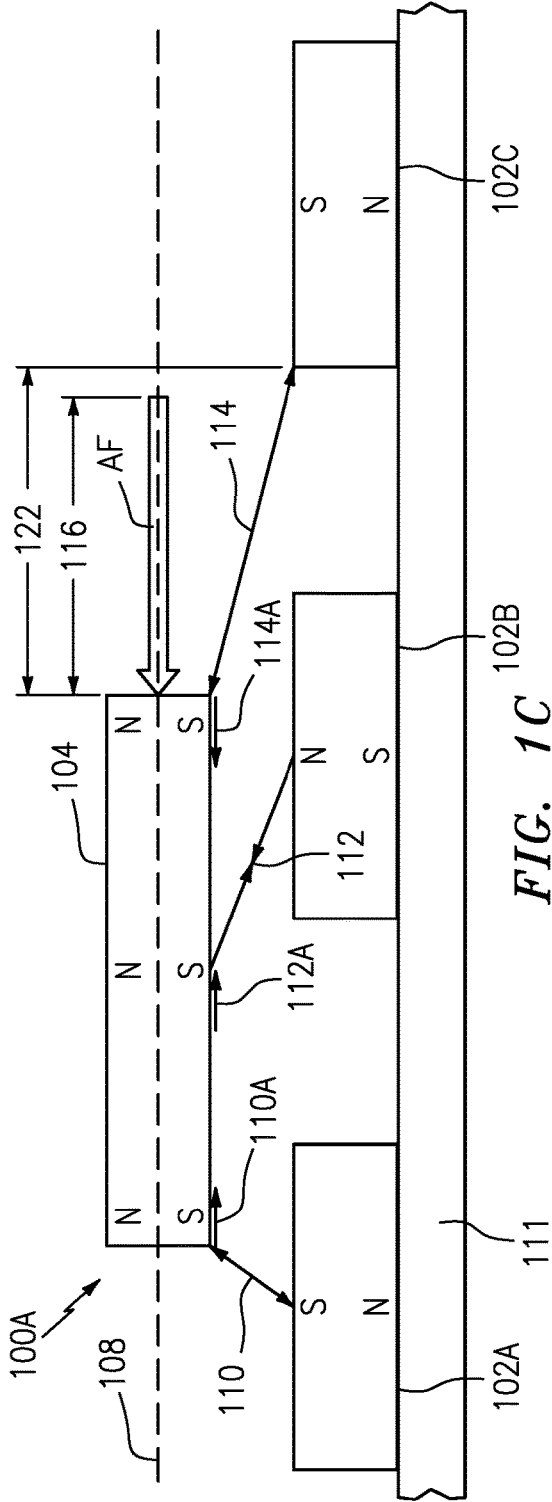

FIG. 1C

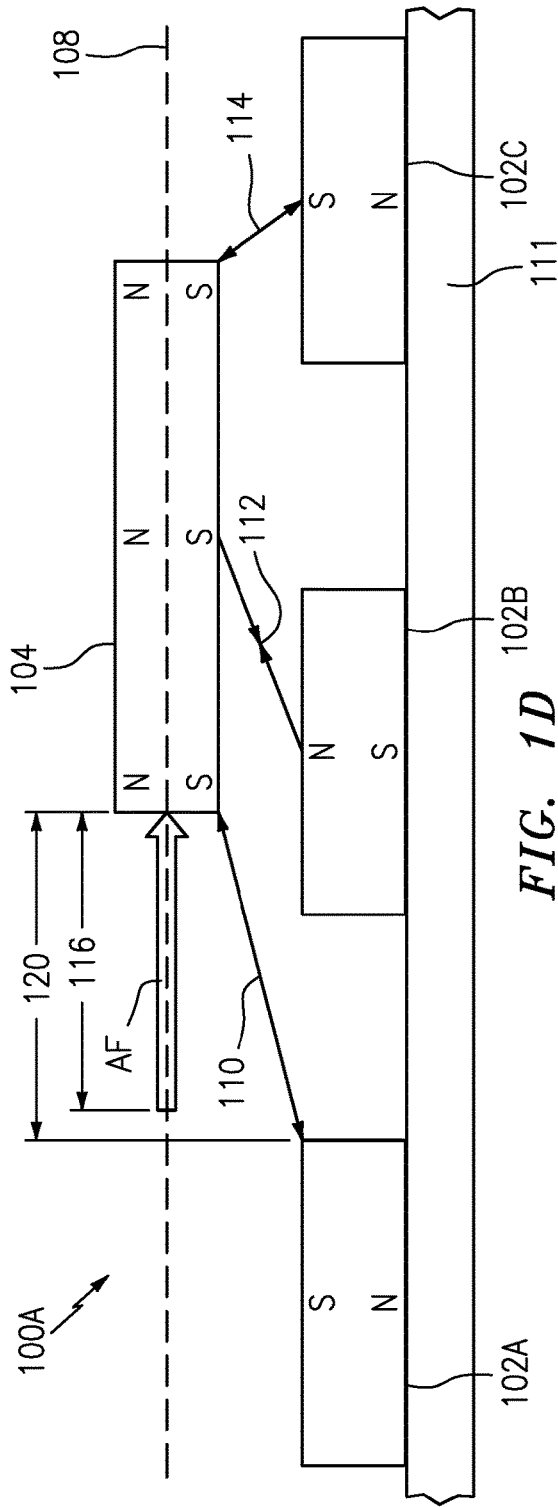

FIG. 1D

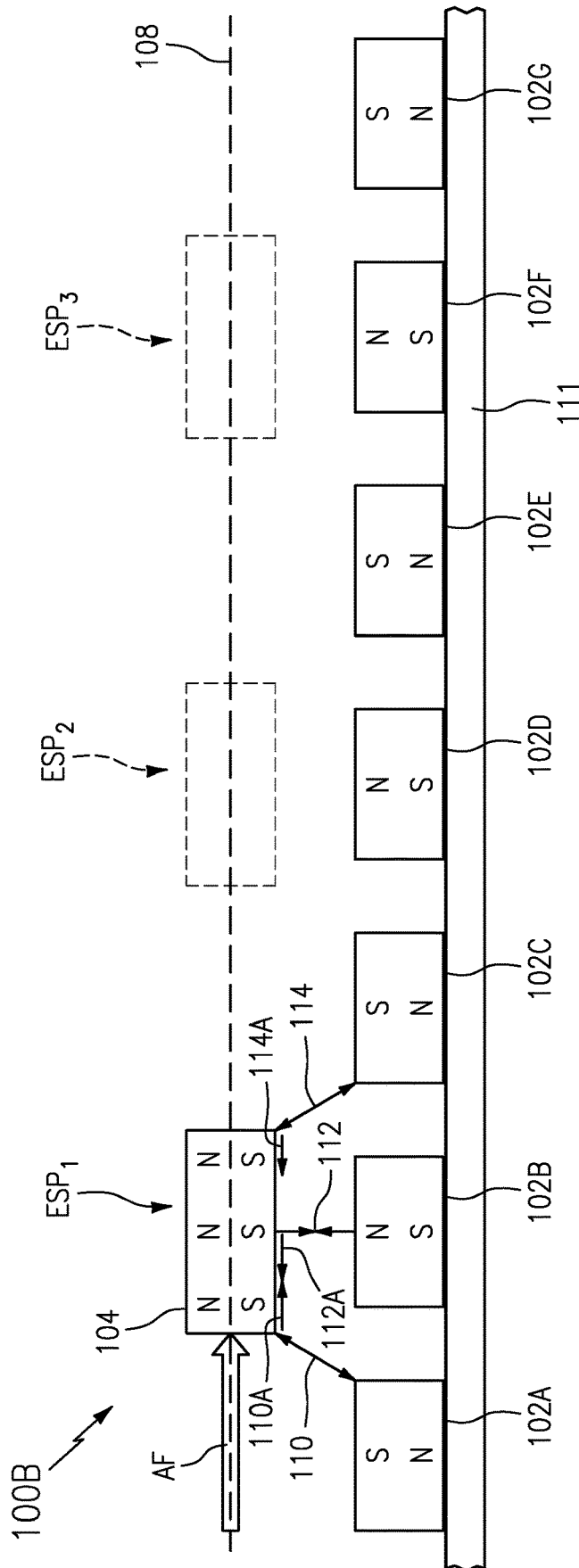

FIG. 1E

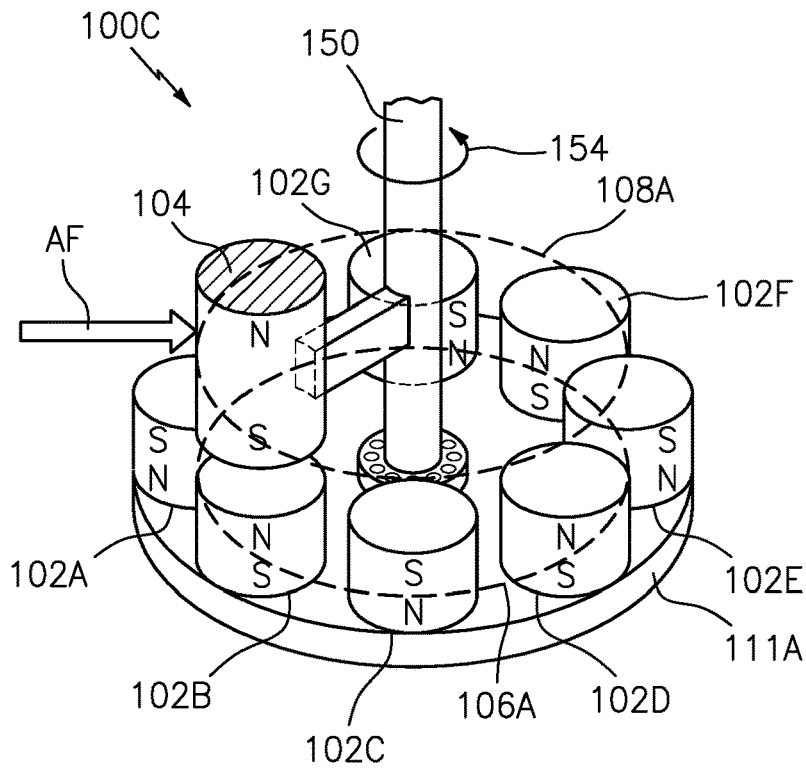

FIG. 1F

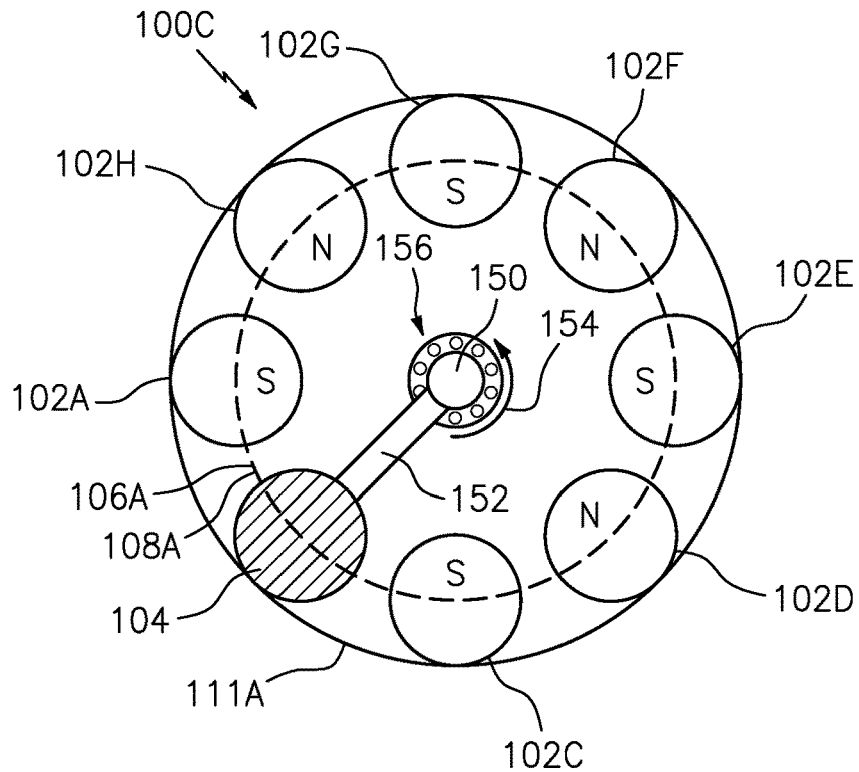

FIG. 1G

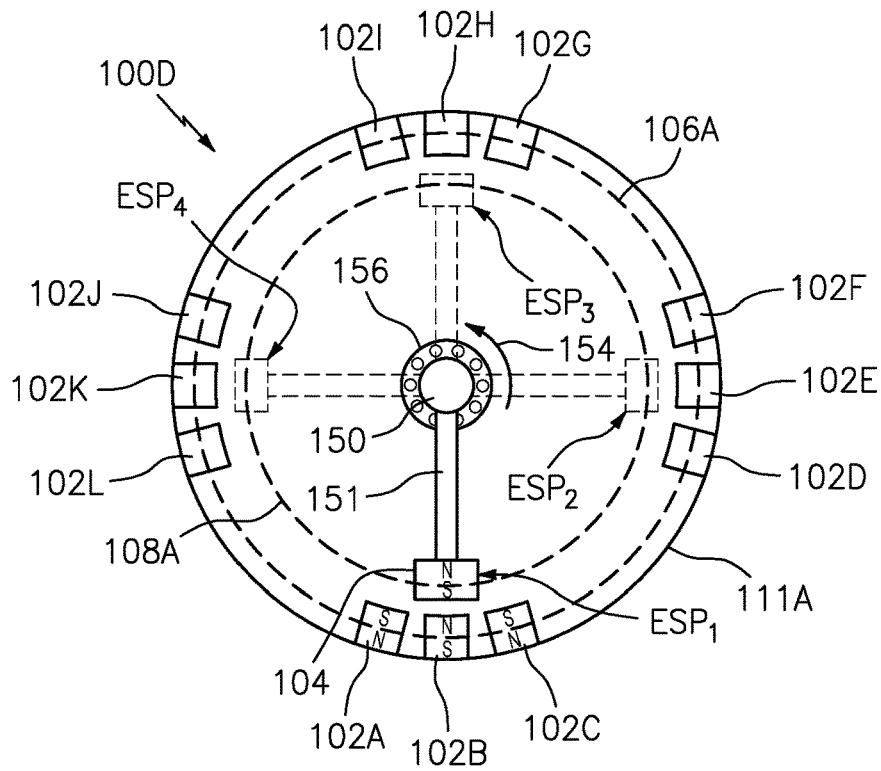

FIG. 1H

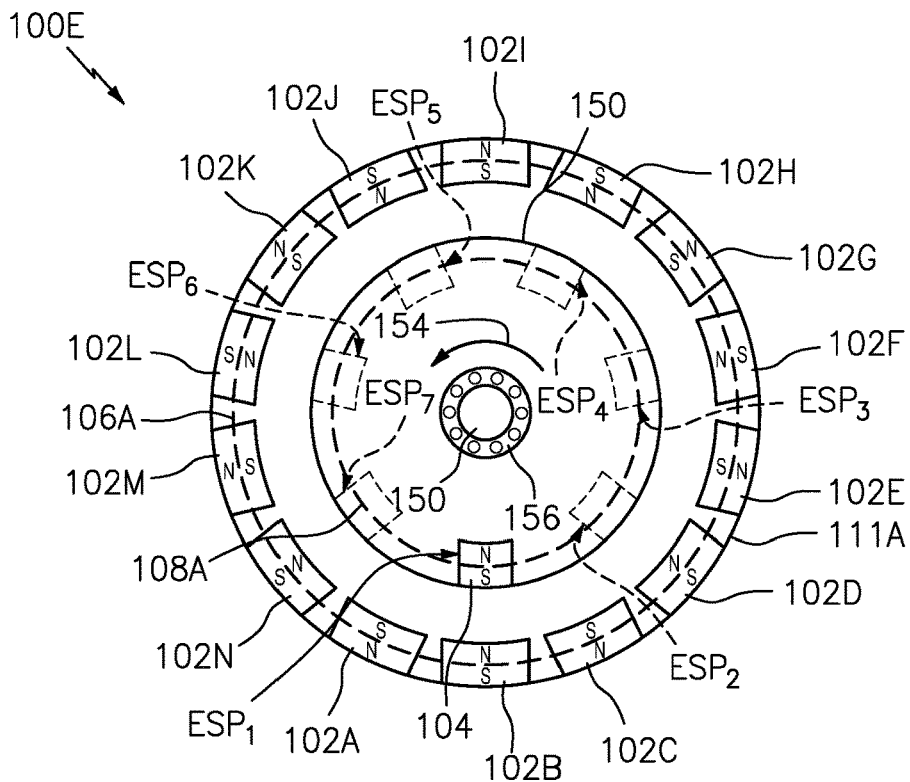

FIG. 1I

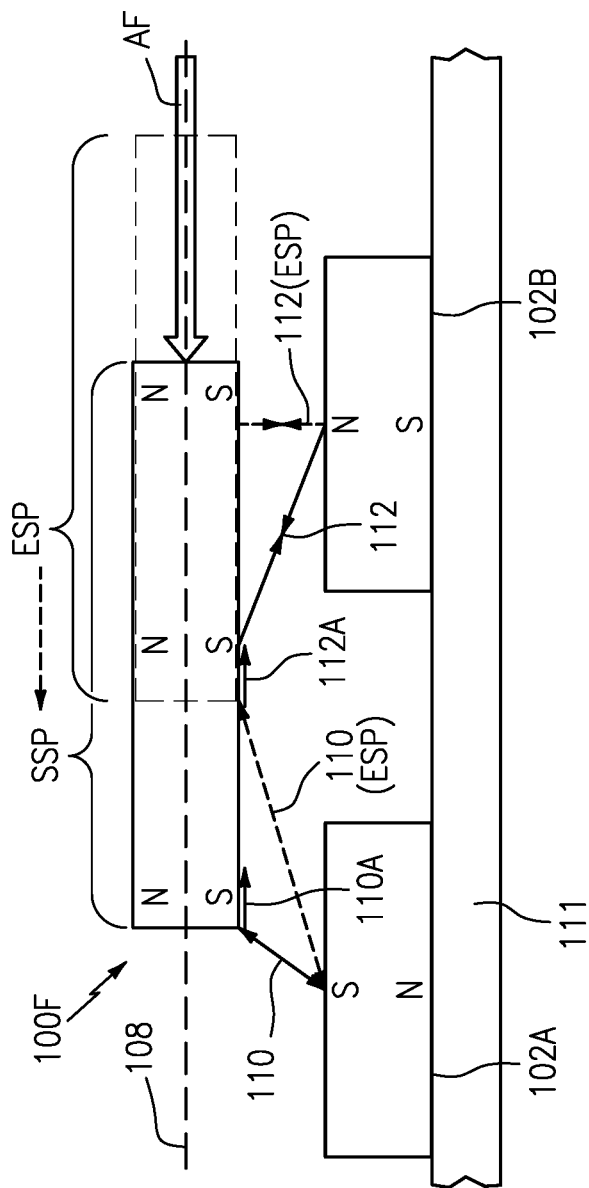

FIG. 1J

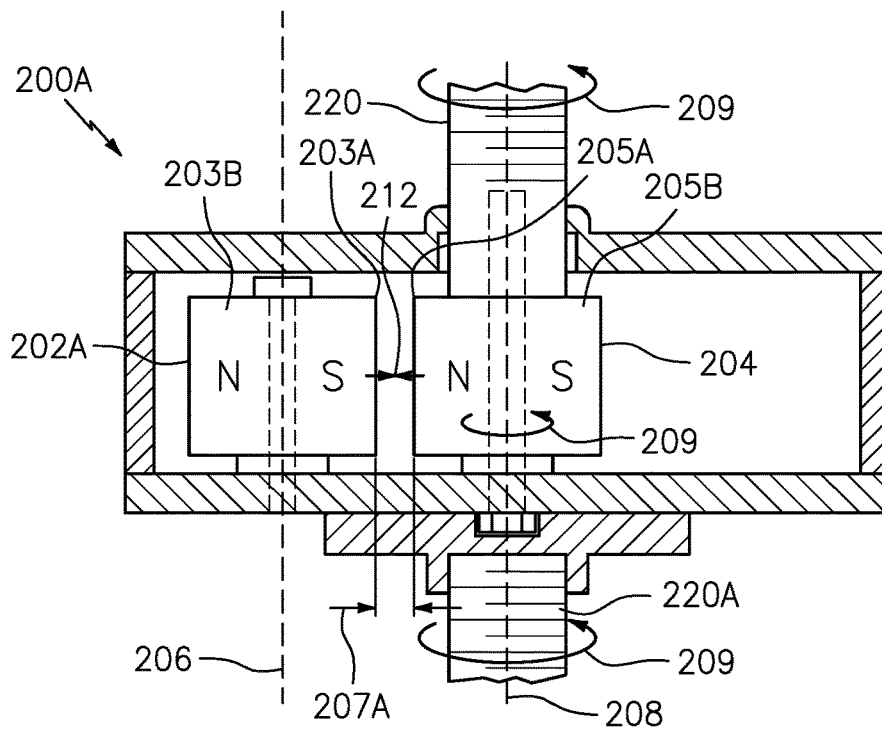

FIG. 2A

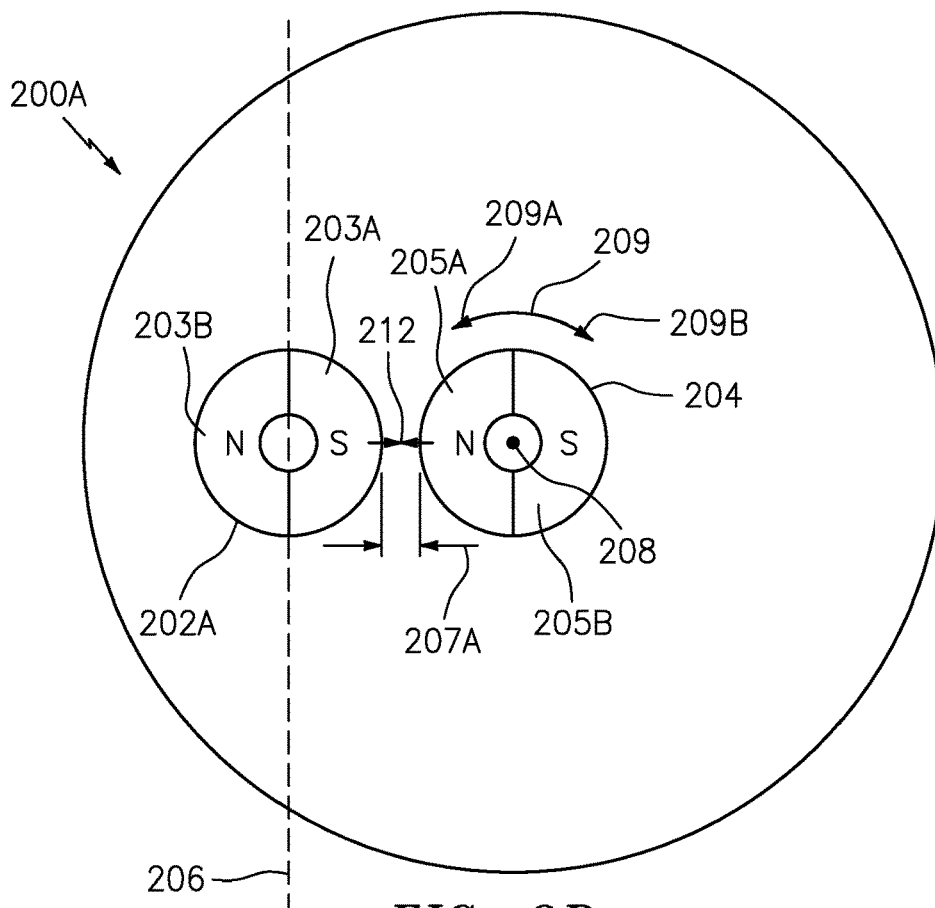

FIG. 2B

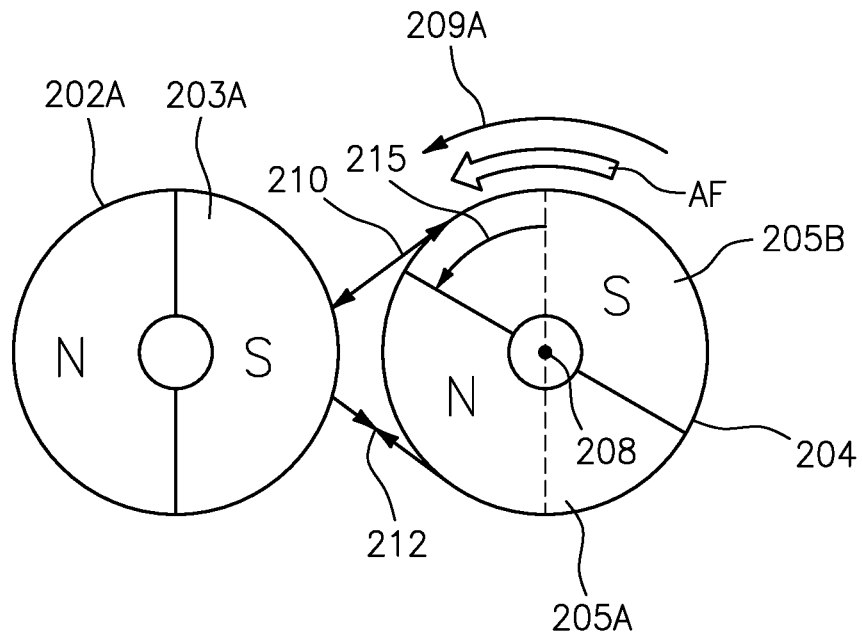

FIG. 2C

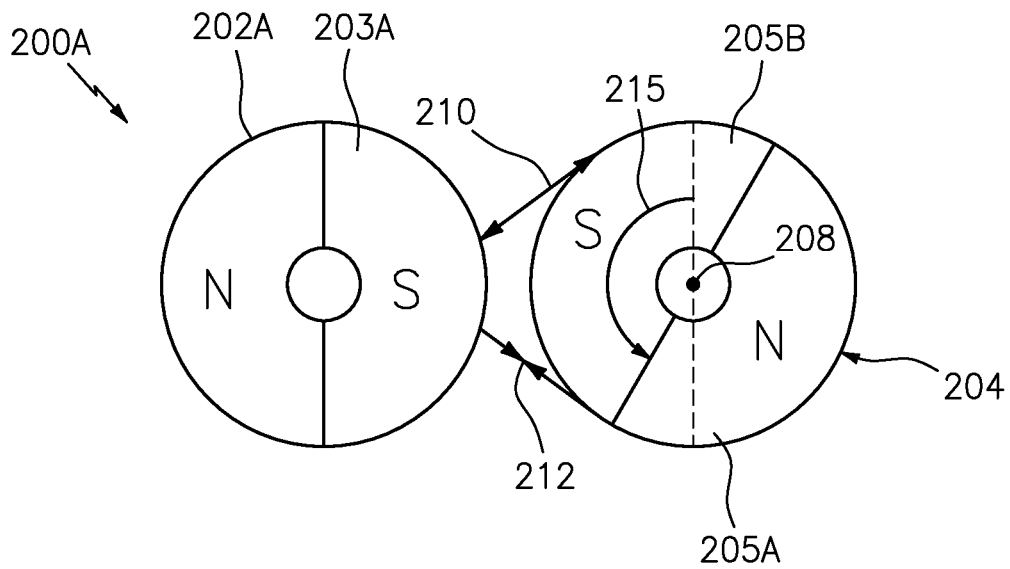

FIG. 2D

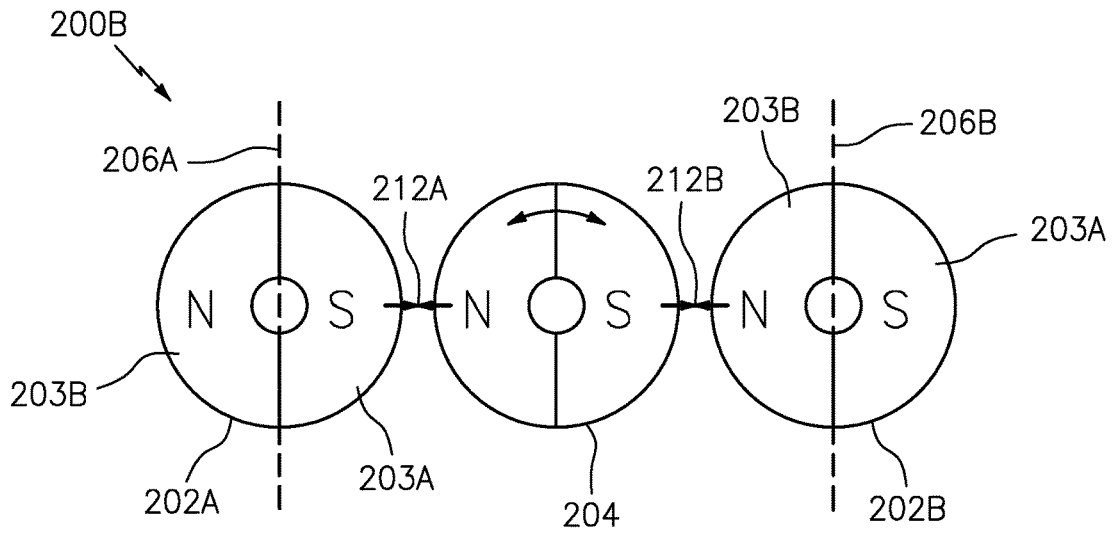

FIG. 2E

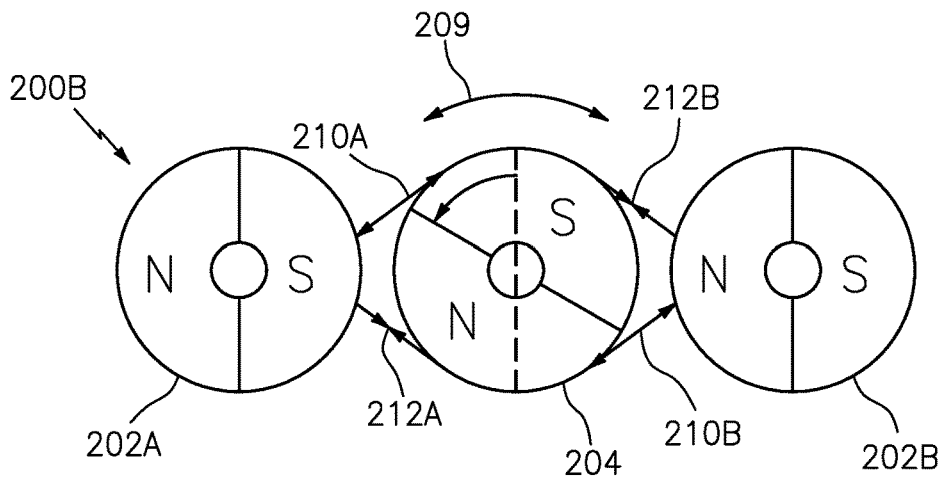

FIG. 2F

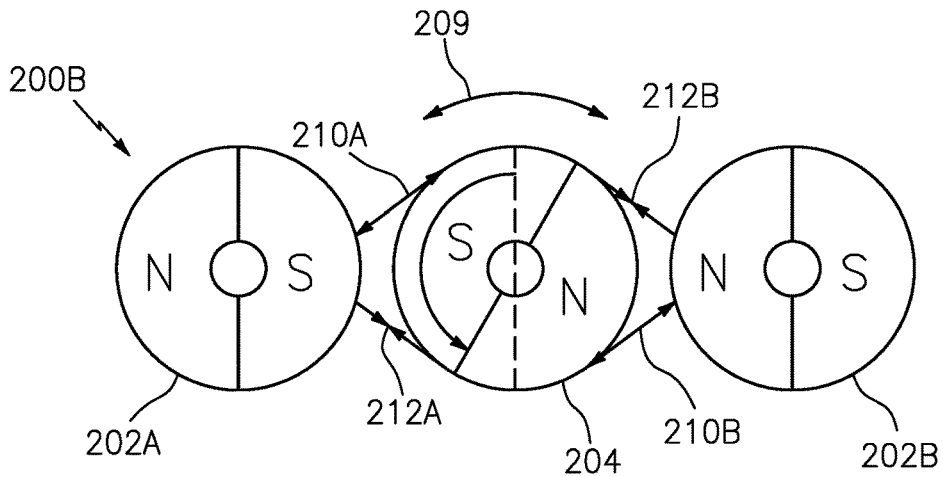

FIG. 2M

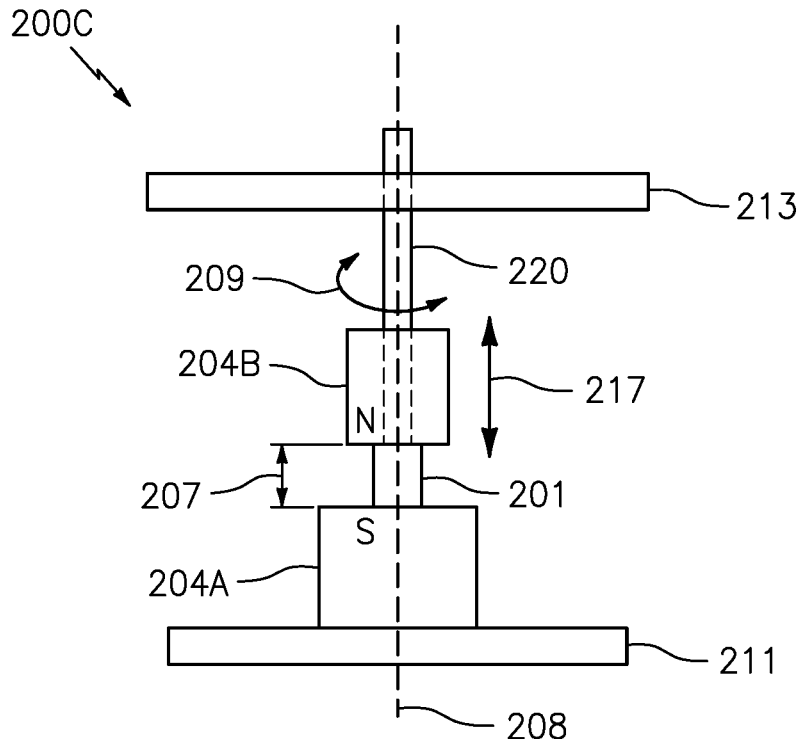

FIG. 2G

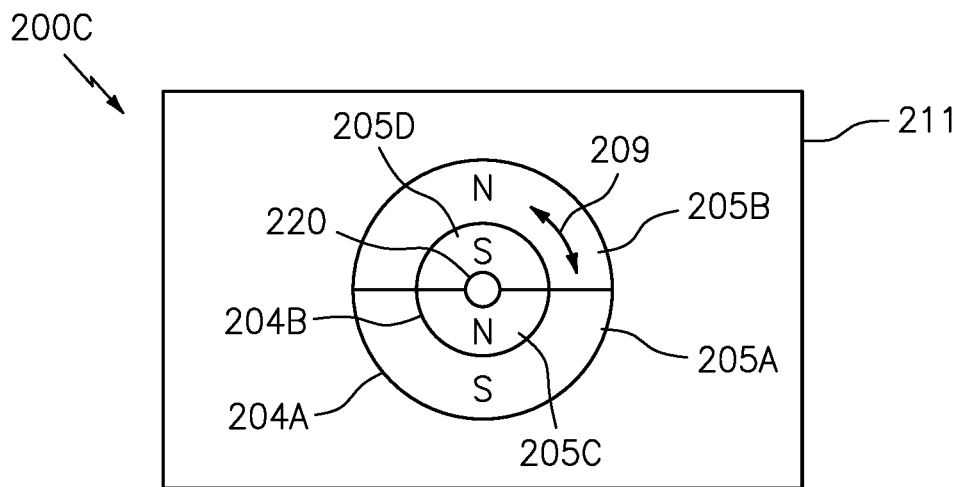

FIG. 2H

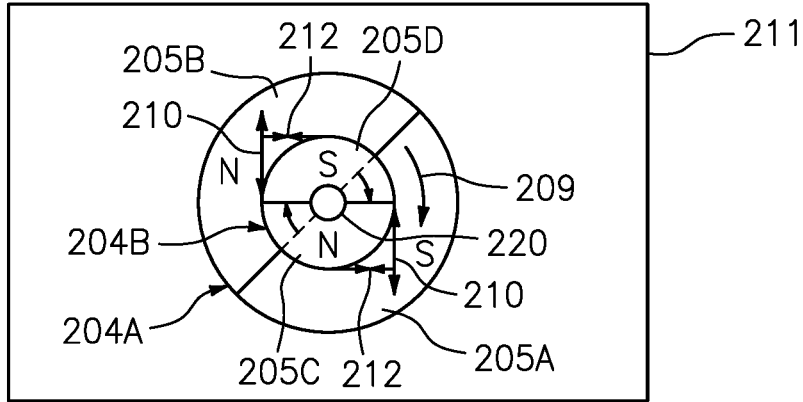

FIG. 2I

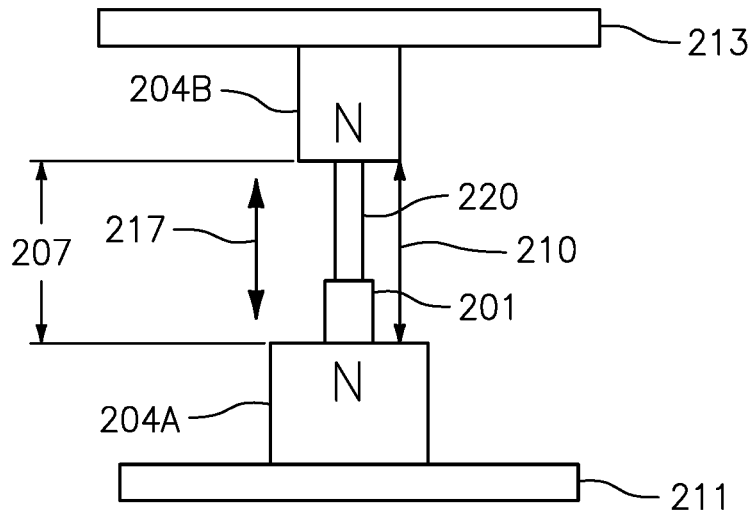

FIG. 2J

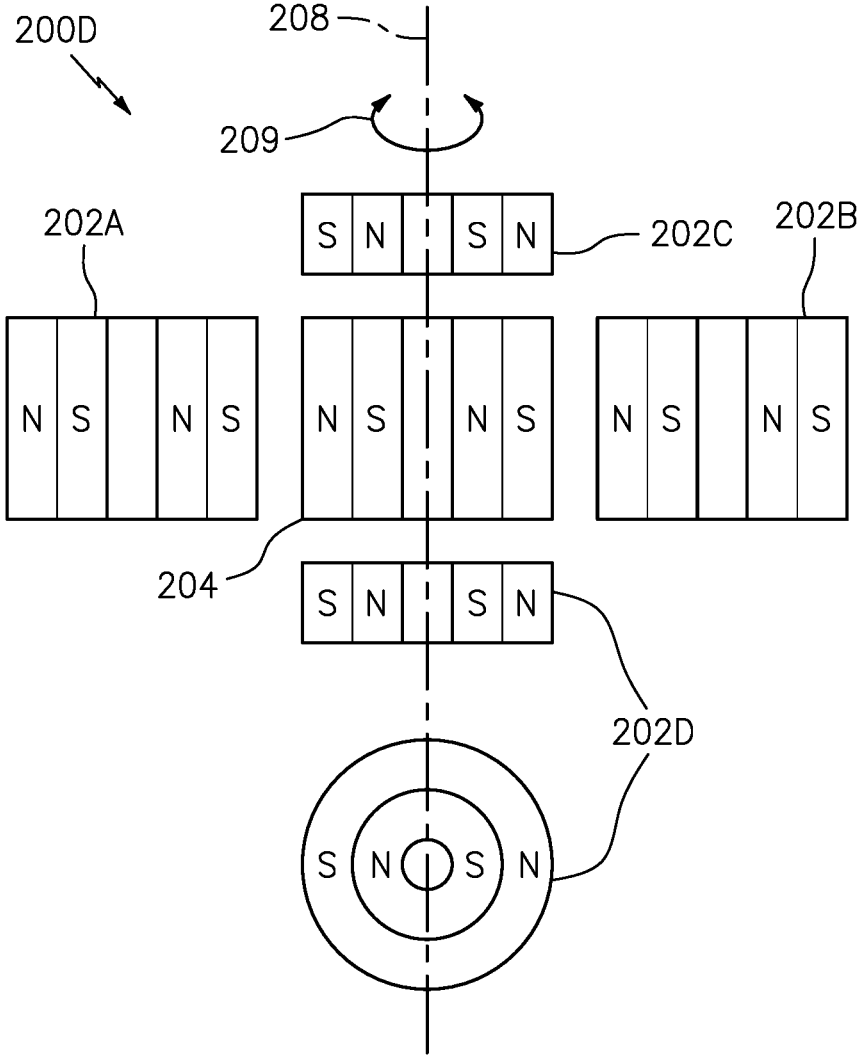

FIG. 2K

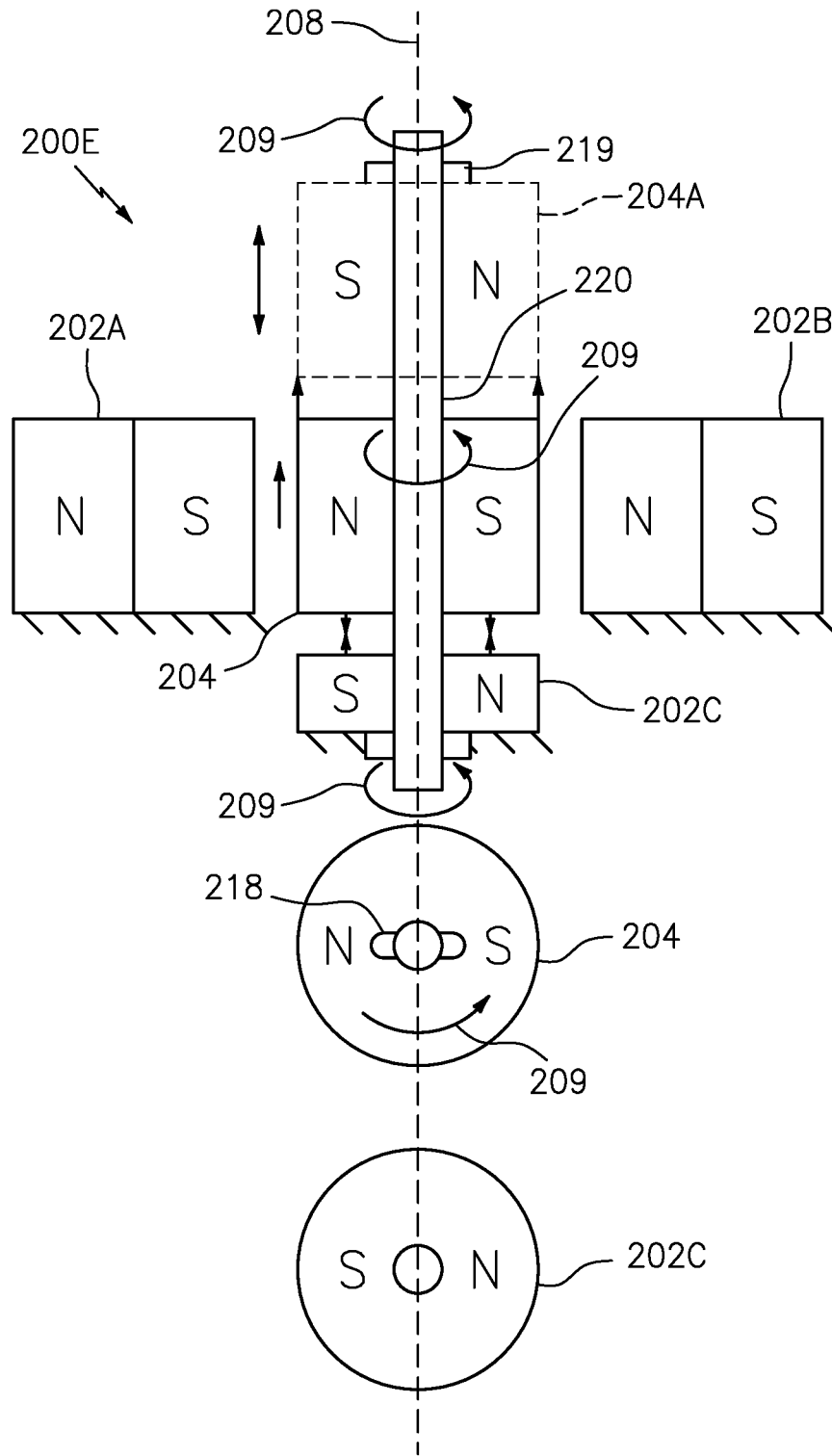

FIG. 2L

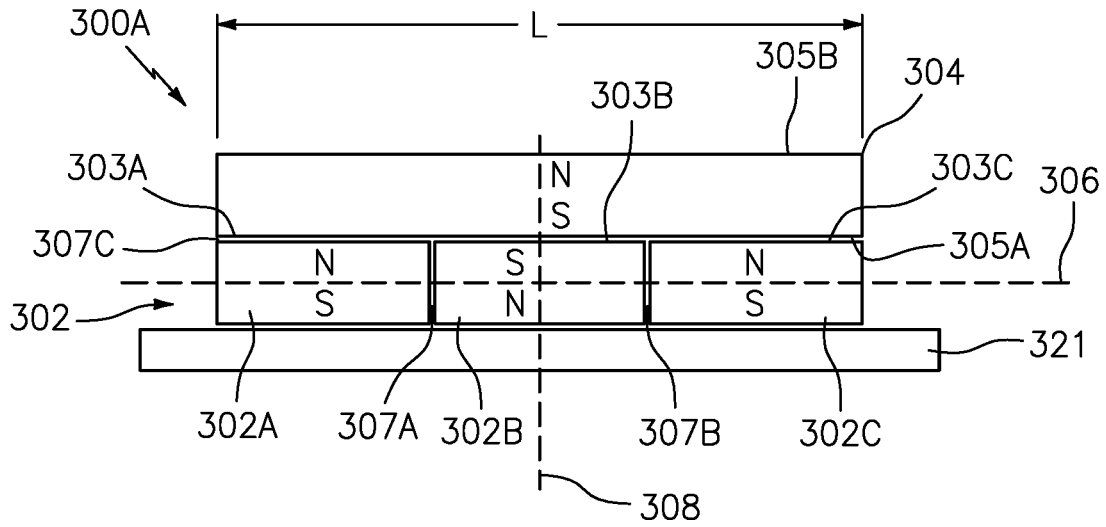

FIG. 3A

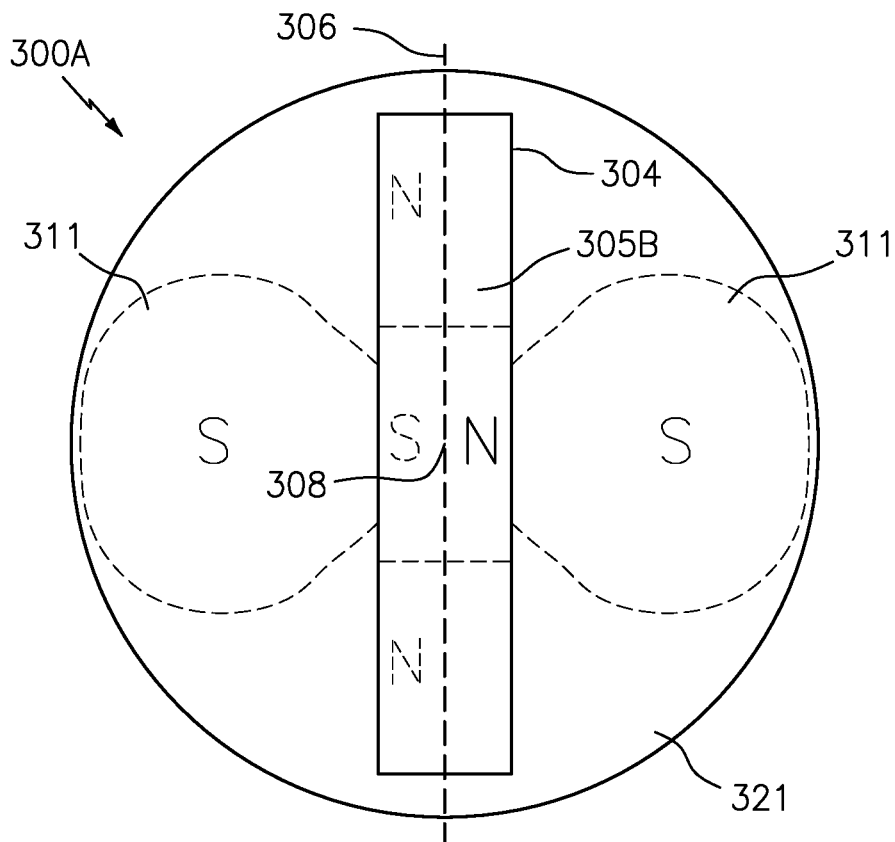

FIG. 3B

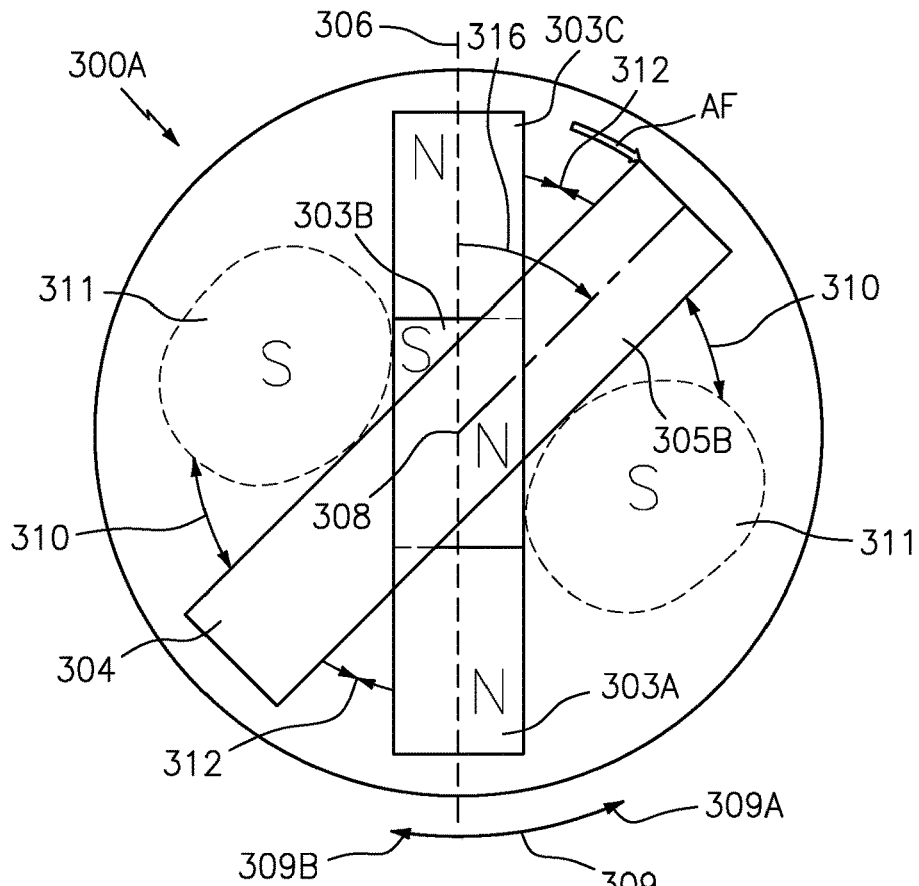

FIG. 3C

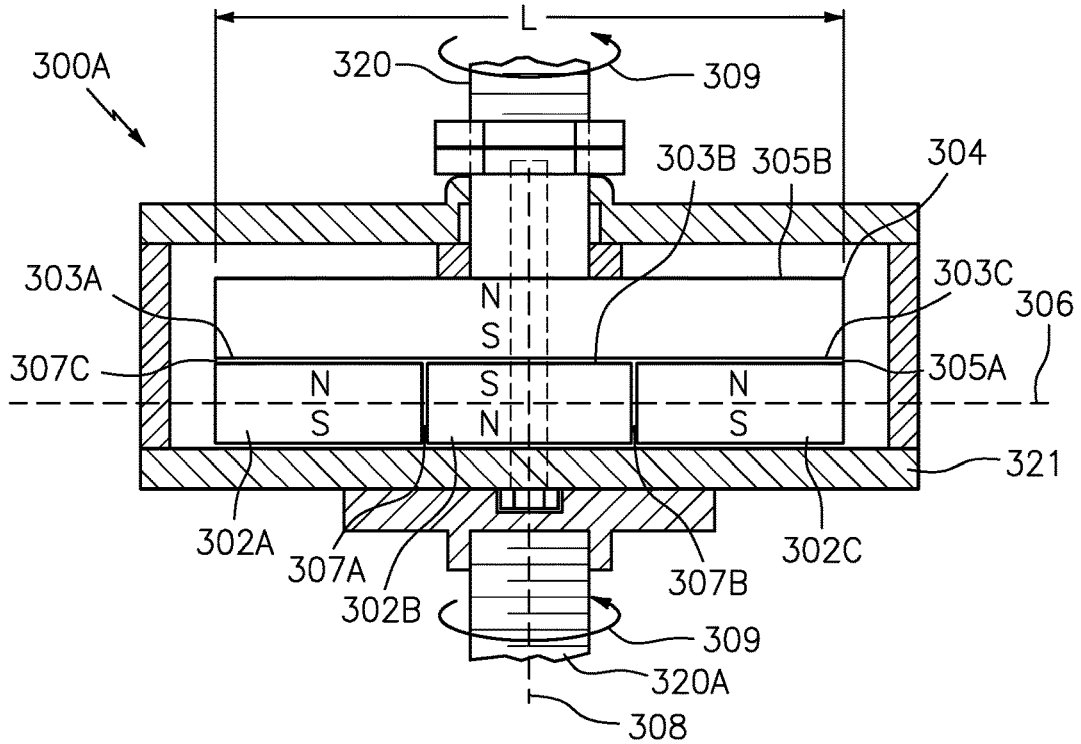

FIG. 3D

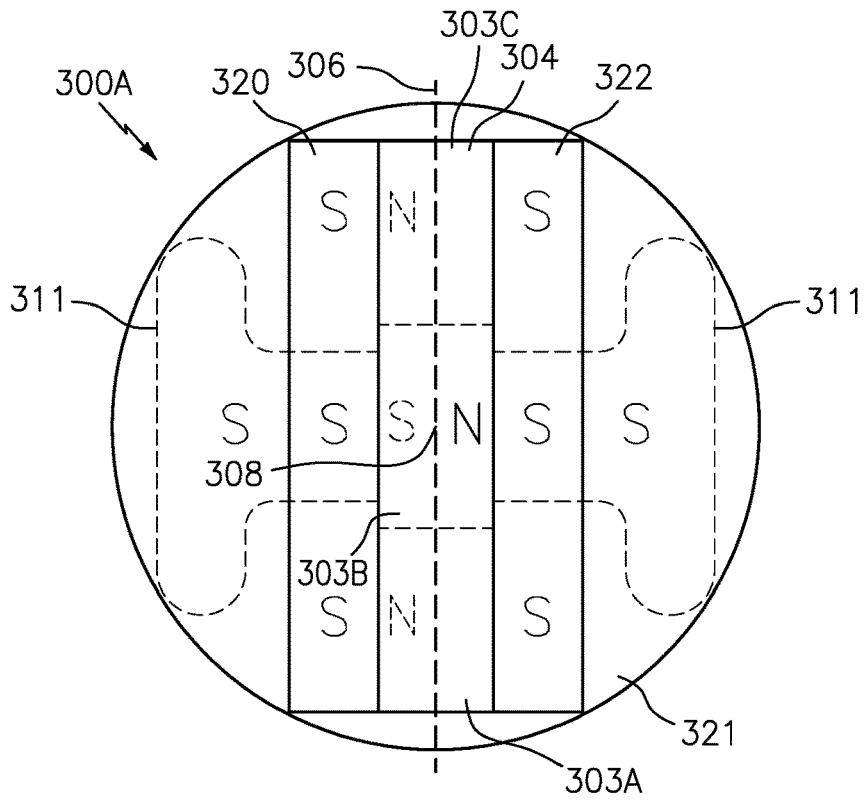

FIG. 3E

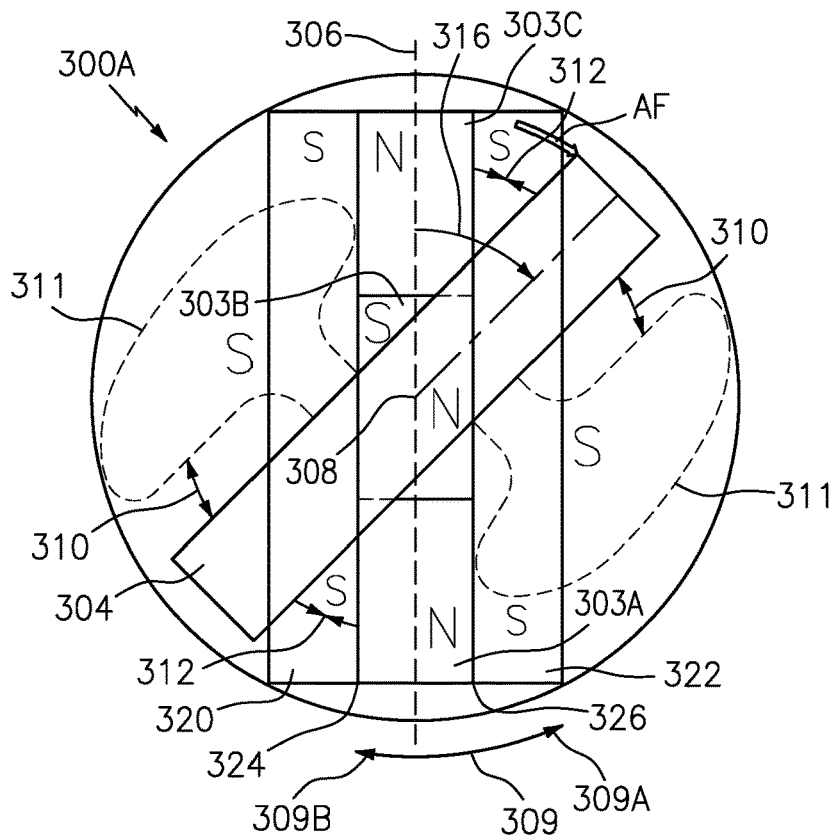

FIG. 3F

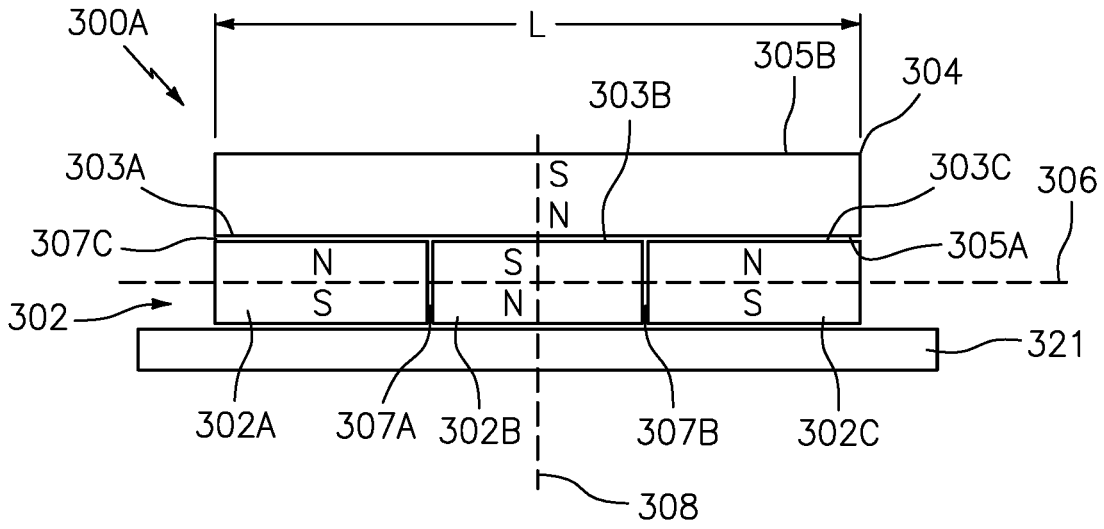

FIG. 3G

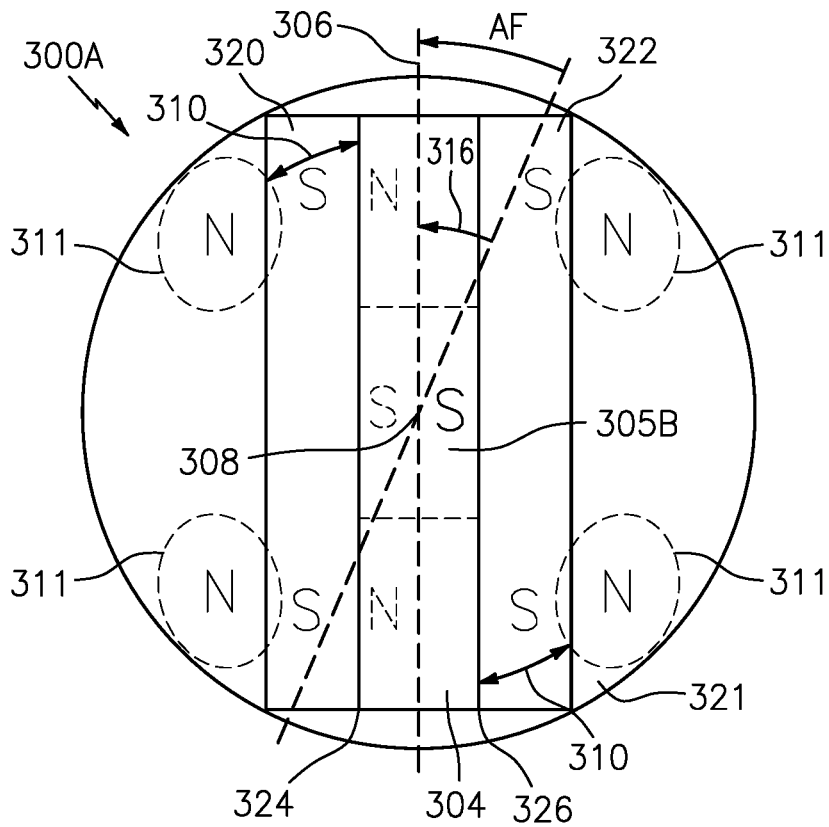

FIG. 3H

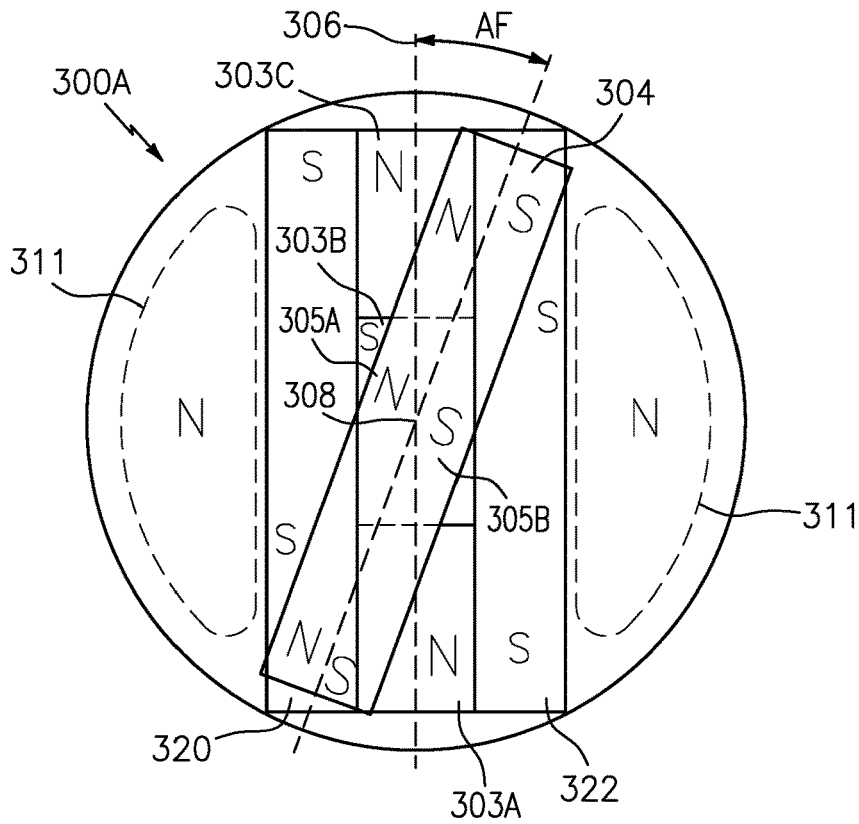

FIG. 3I

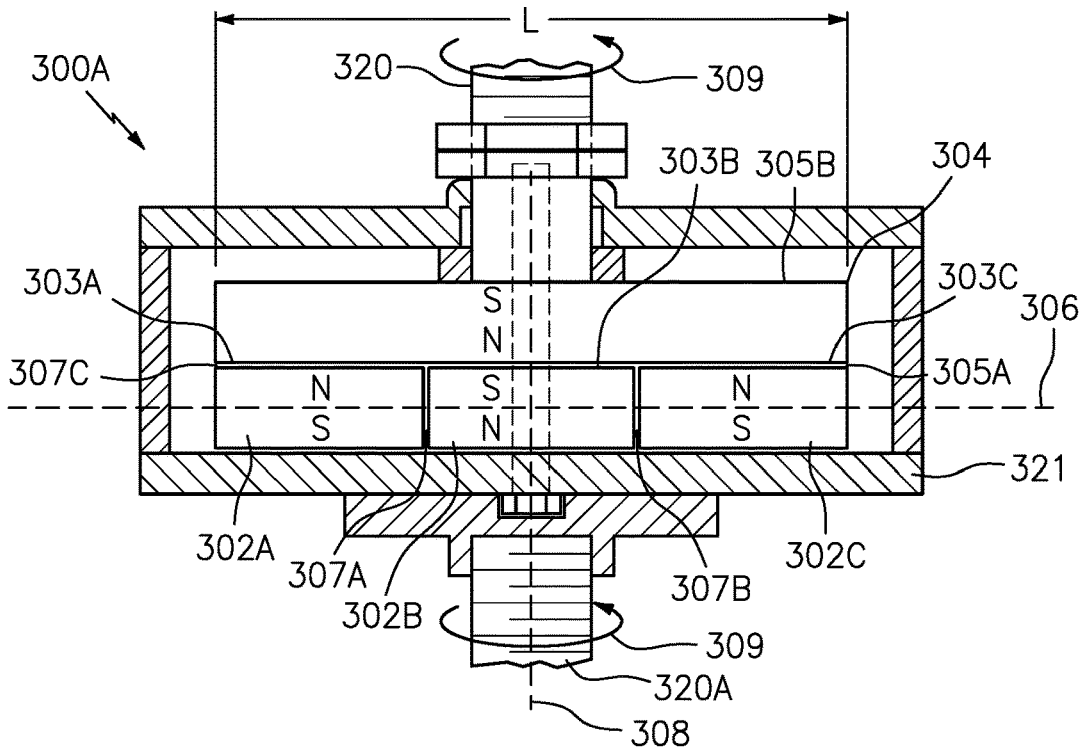
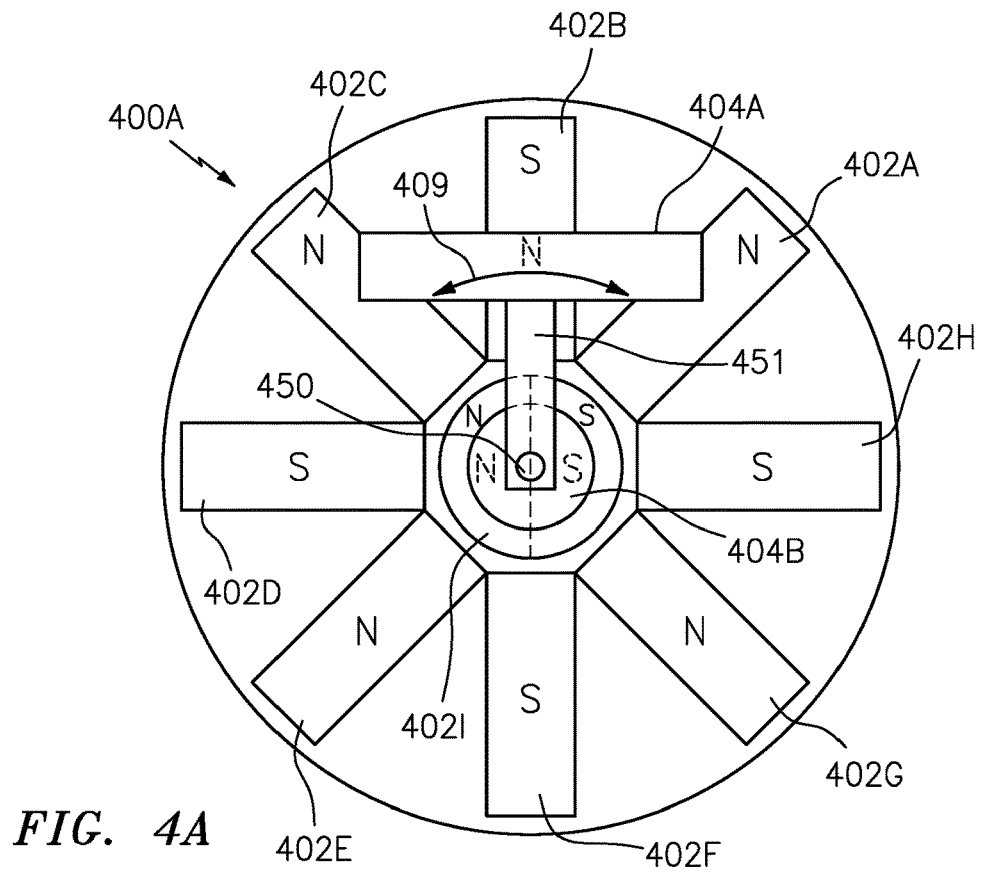
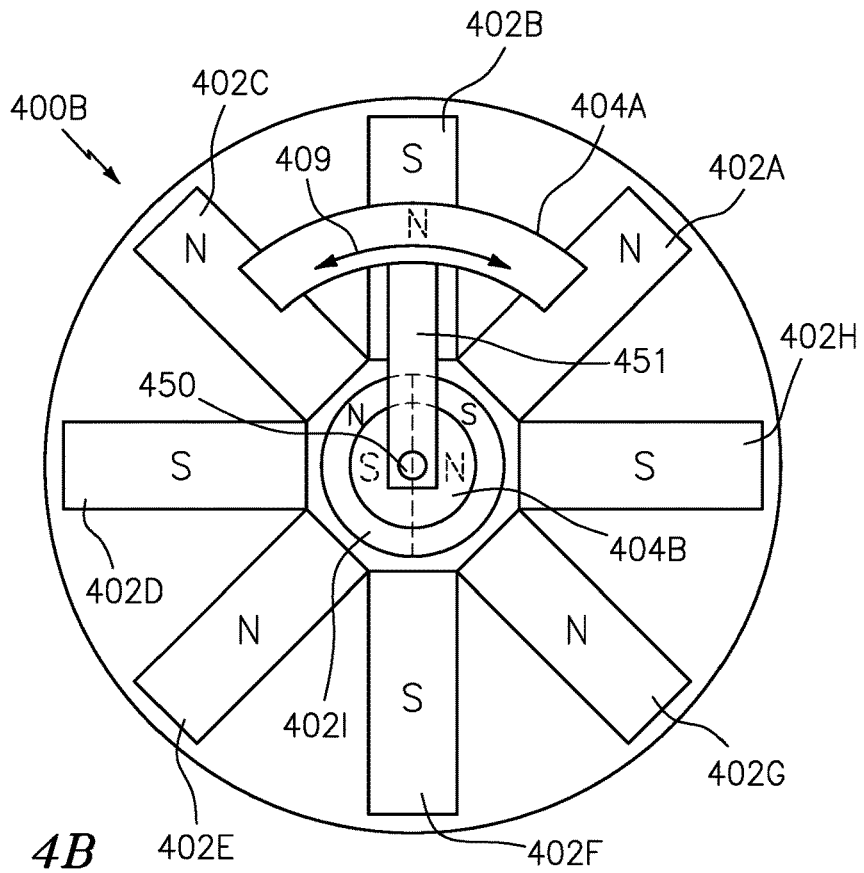

FIG. 3J



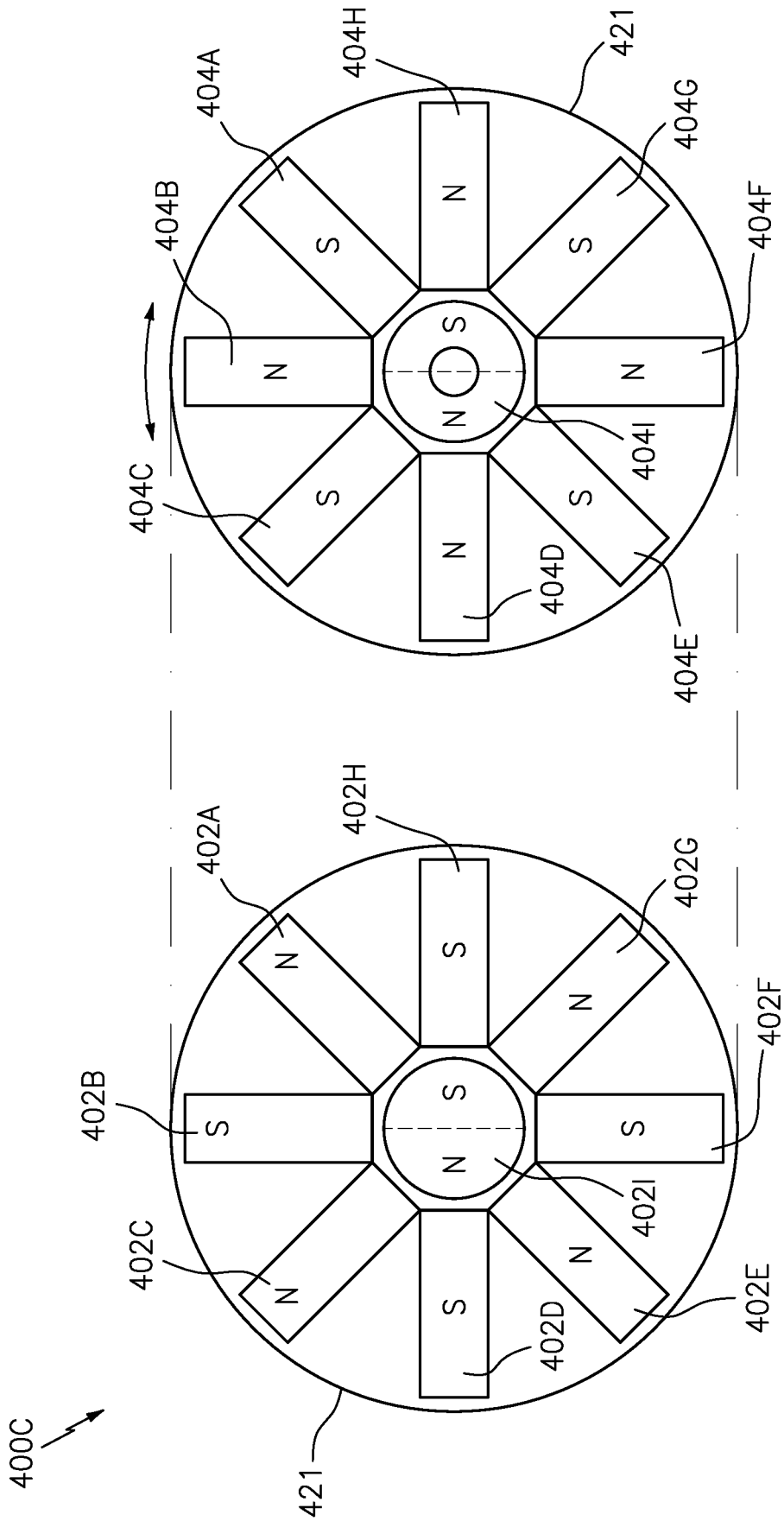

FIG. 4C

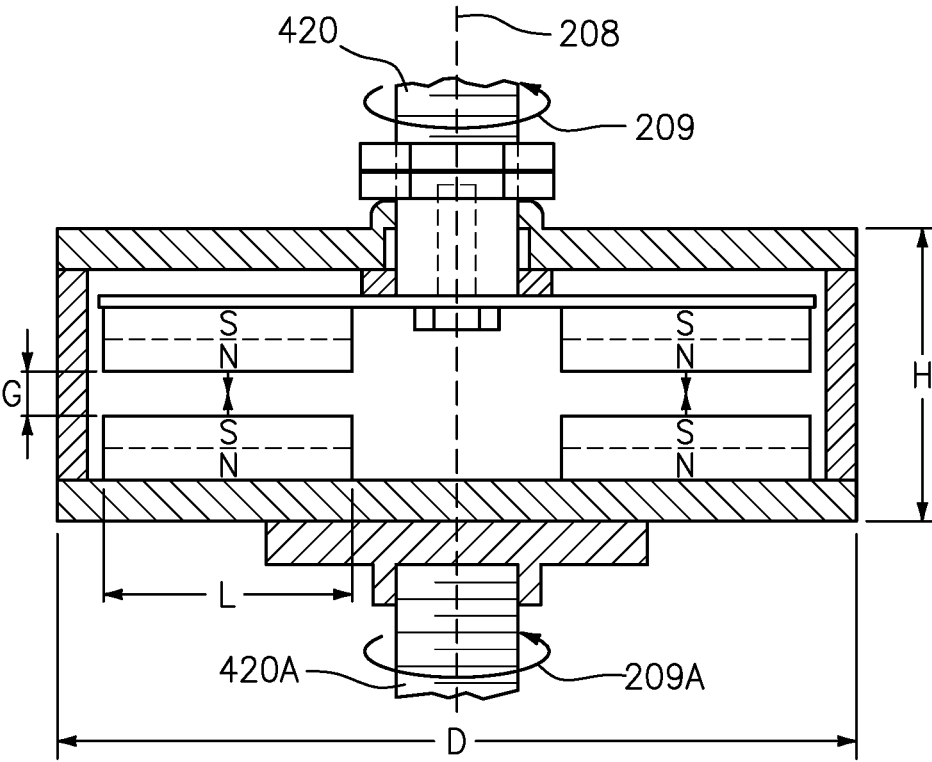

FIG. 4D

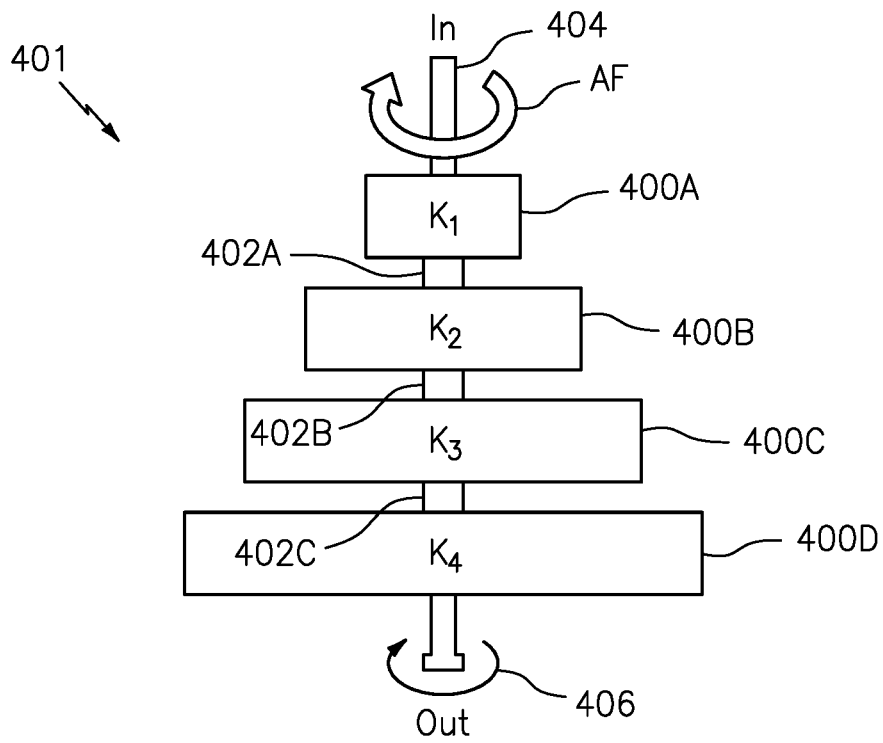

FIG. 5A

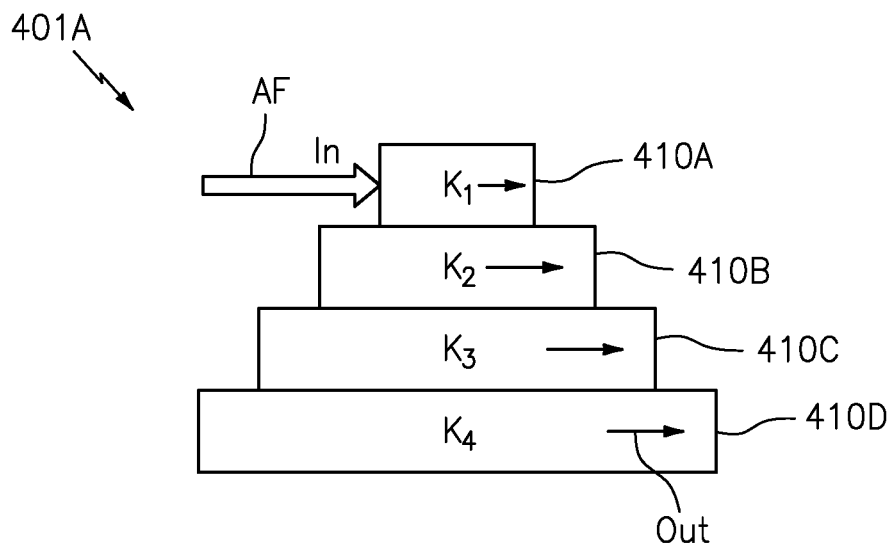

FIG. 5B

Data For Curve

Angle (Deg.) Deflection	Lbs Force	Delta Force
0	0	0
30	2.6	2.6
60	4	1.4
90	5.6	1.6
120	3.8	-1.8
150	1.6	-2.2
180	0	-1.6

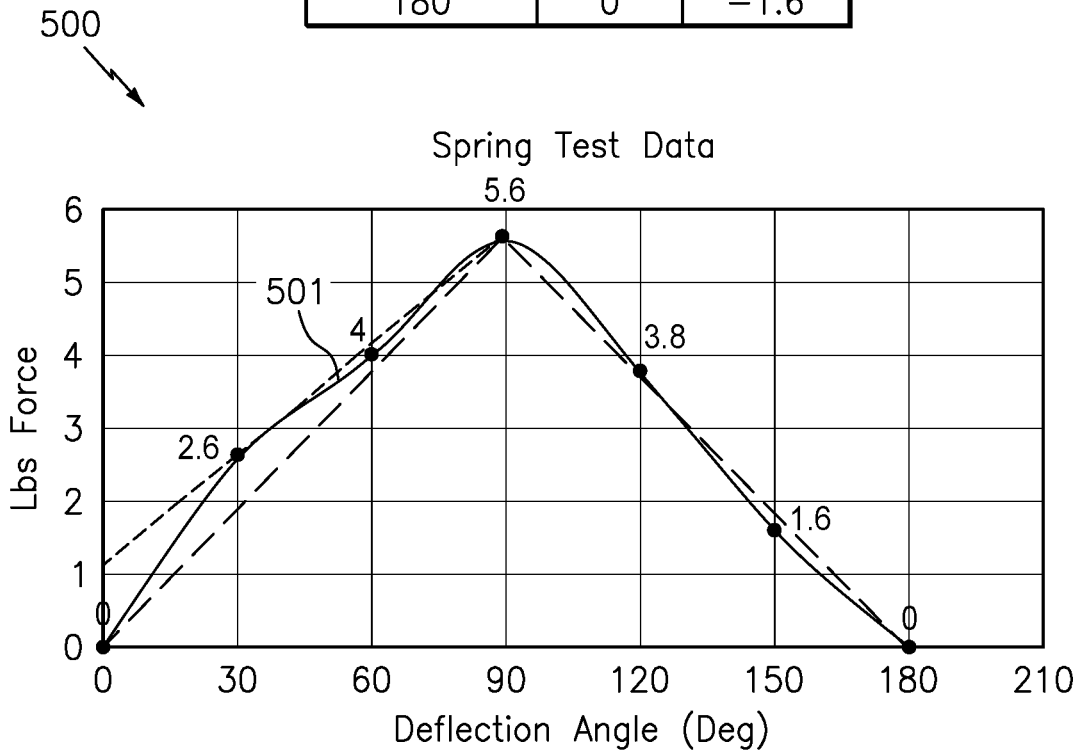
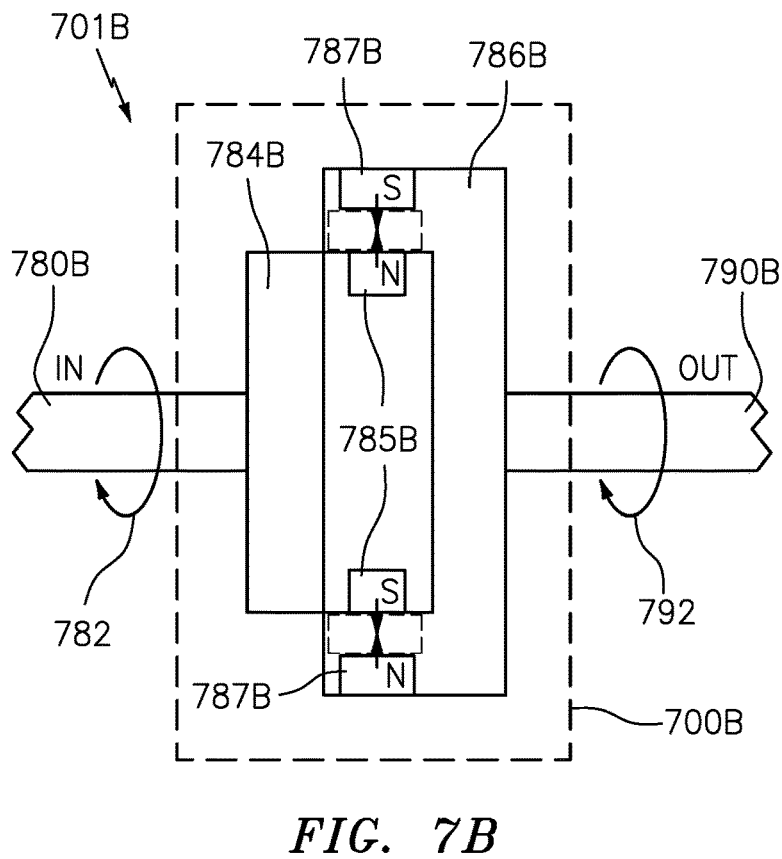
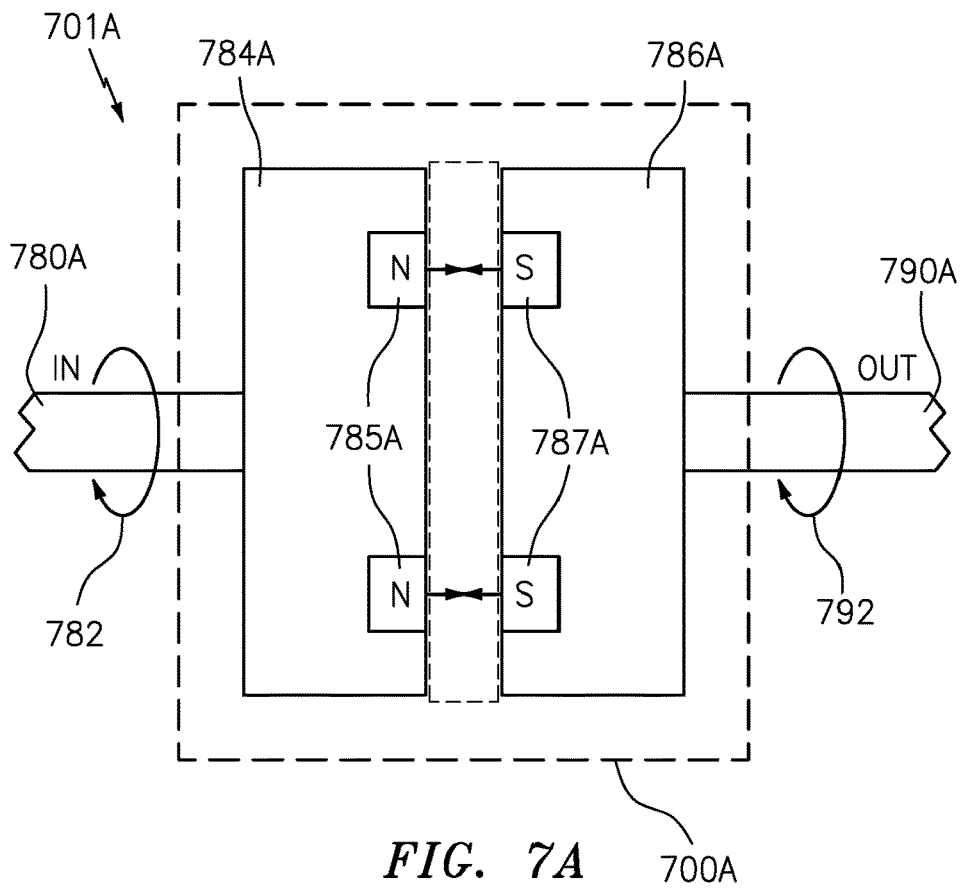

FIG. 6



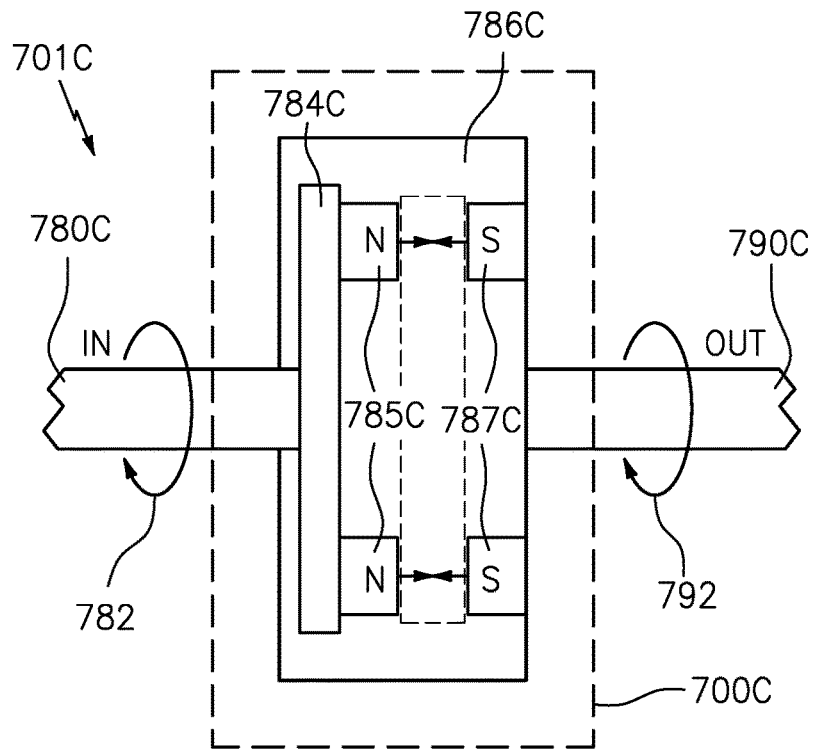

FIG. 7C

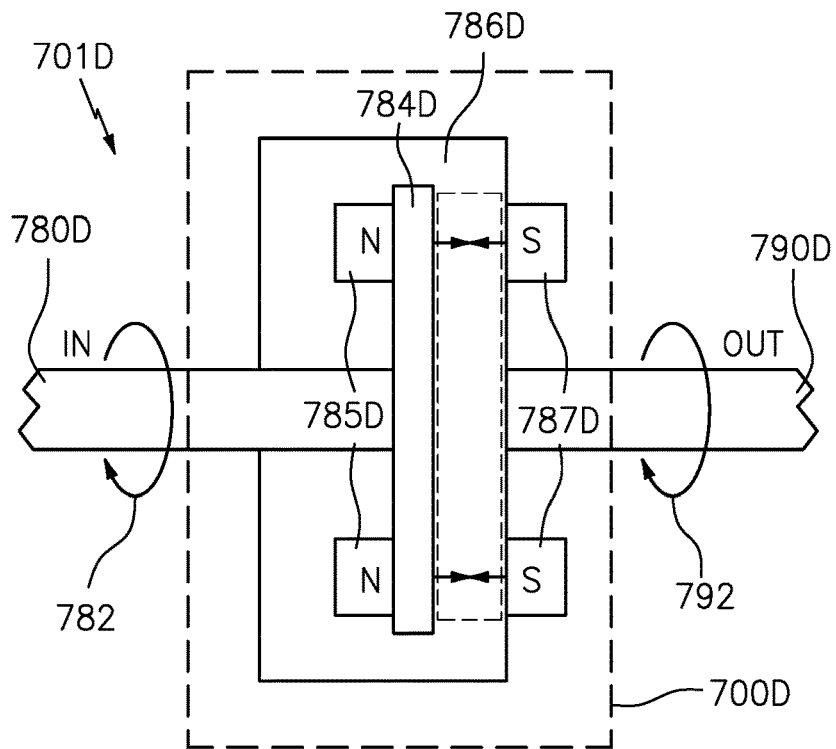

FIG. 7D

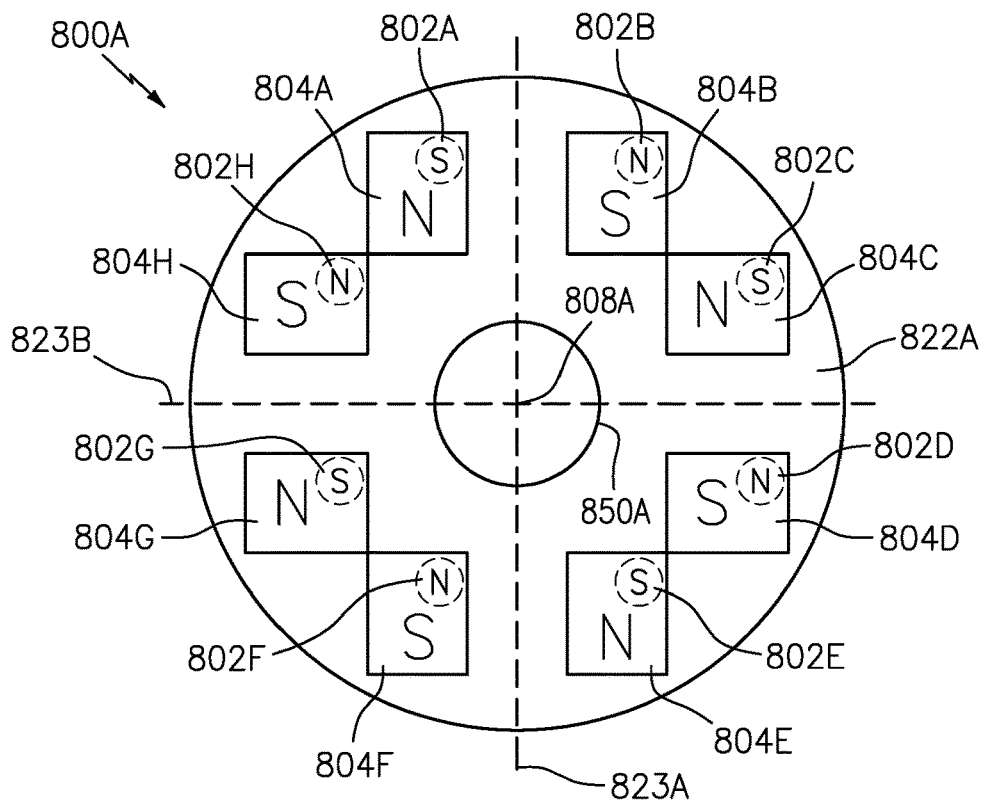

FIG. 8A

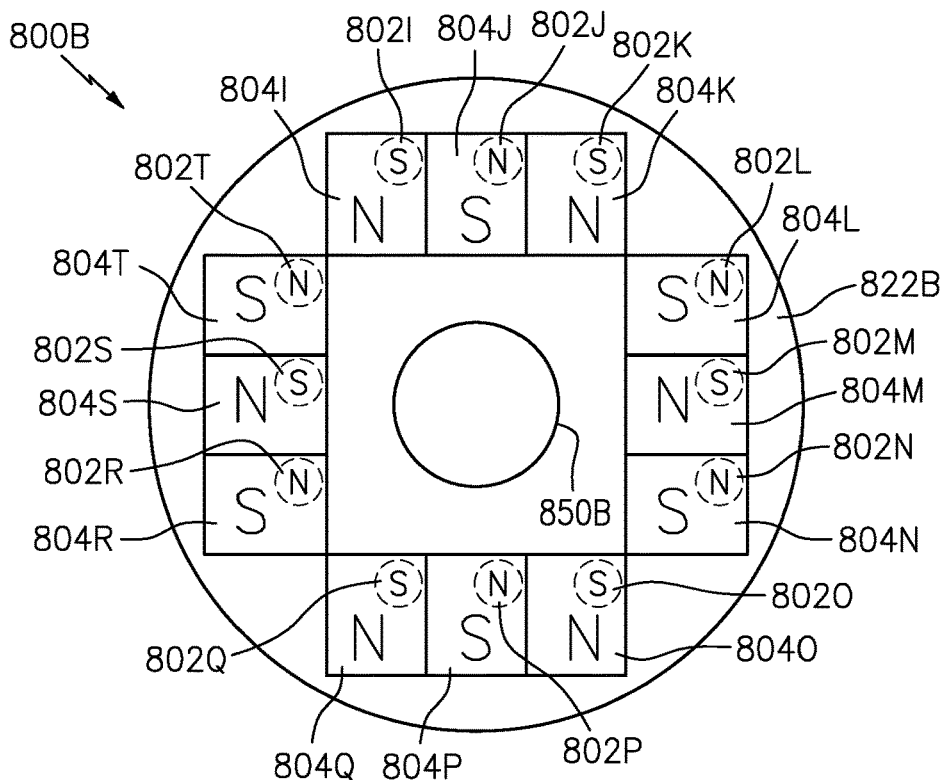

FIG. 8D

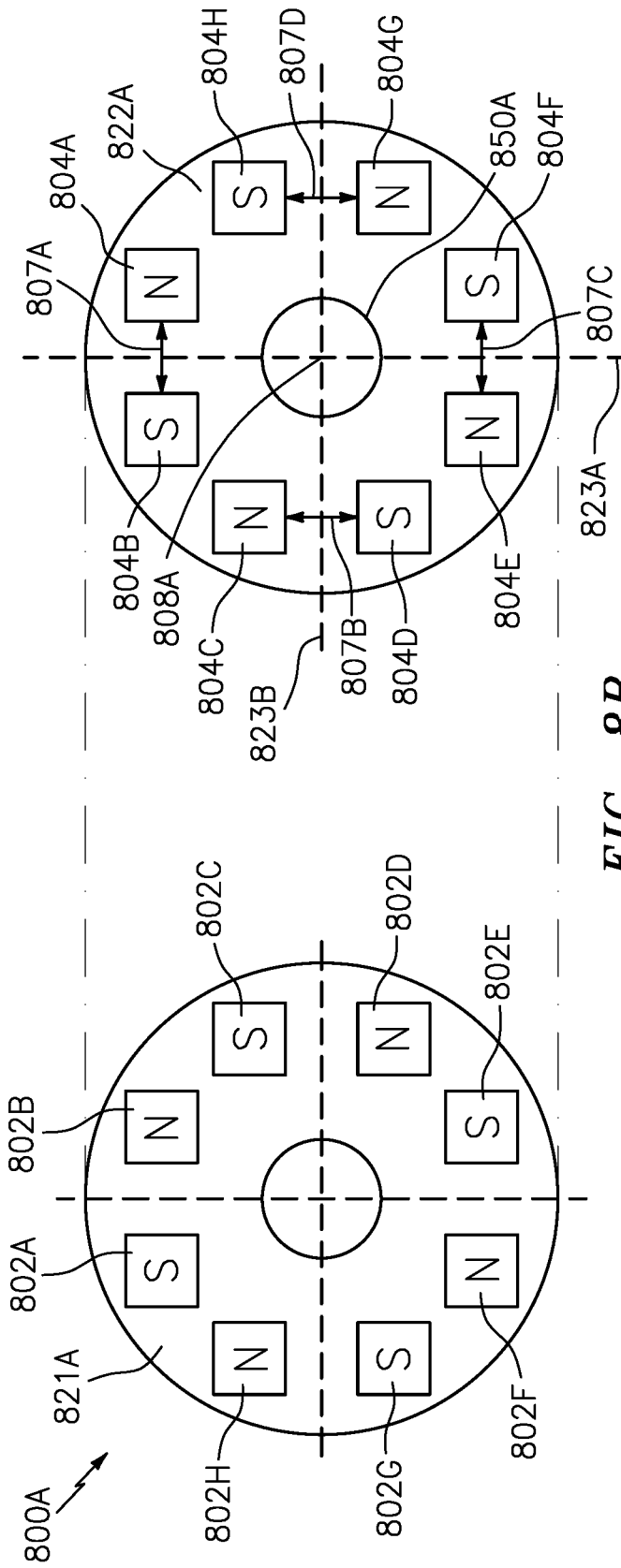

FIG. 8B

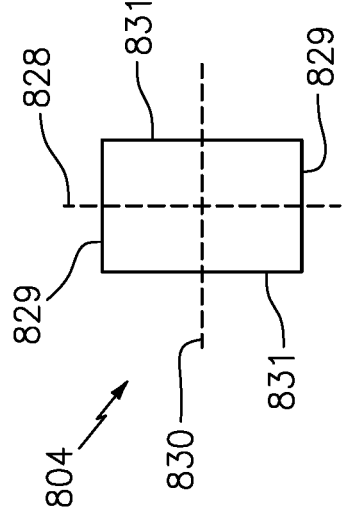

FIG. 8C

MAGNETICALLY-COUPLED TORQUE-ASSIST APPARATUS

CROSS-REFERENCE TO RELATED APPLICATIONS

[0001] This application is a continuation-in-part application of U.S. patent application Ser. No. 16/738,352 filed on Jan. 9, 2020, which claims the benefit of U.S. Provisional Patent Application No. 62/872,030 filed on Jul. 9, 2019, and which claims the benefit of U.S. Provisional Patent Application No. 62/917,939 filed on Jan. 9, 2019, each of which is hereby incorporated by reference in its entirety, to the fullest extent permitted under applicable law.

BACKGROUND

[0002] Conventional mechanical springs or coils are known for converting mechanical kinetic energy (e.g., force-in) applied to the spring, into elastic potential energy stored in the spring, and then, when the input force is removed, converting (or releasing) the stored potential energy back into mechanical kinetic energy (e.g., distance or motion or force-out). Springs also may provide predictable and repeatable force-in/distance-out characteristics (e.g., linear regions of operation) which allows them to be used in systems/applications that require such performance. Various types and configurations of springs include compression springs, extensions springs, torsion (or rotational) springs and the like. Springs are typically made of steel or metal alloys or non-metallic materials such as plastic. The material and type of spring is based on the type of application, as is known. Conventional springs are used in many different applications and systems, e.g., clocks/watches, doors/hinges/latches, shock-absorbers/suspensions, and many other applications/devices.

[0003] However, conventional springs present several problems. In particular, conventional springs are vulnerable to wear and/or structural fatigue or failure during use (including breakage), which may require repair or replacement in the application or system in which the spring is utilized. Springs may also become stretched beyond their design limits (e.g., over deflection due to excessive weight load or input force), which may cause permanent structural deformation or damage to the spring.

[0004] It is also known to use a magnetic-based coupling on a rotating shaft between an input (or applied) rotational force and a rotational load, to improve efficiency and/or to reduce maintenance costs. However, such devices can be expensive and complex to manufacture.

[0005] Accordingly, it would be desirable to design a device that overcomes the above problems and shortcomings while retaining the benefits.

BRIEF DESCRIPTION OF THE DRAWINGS

[0006] FIG. 1A is a side view of a magnetically-coupled device in accordance with embodiments of the present disclosure.

[0007] FIG. 1B is a top view of the magnetically-coupled device of FIG. 1A in accordance with embodiments of the present disclosure.

[0008] FIG. 1C is a side view of the magnetically-coupled device of FIG. 1A in operation in accordance with embodiments of the present disclosure.

[0009] FIG. 1D is a side view of the magnetically-coupled device of FIG. 1A in operation in accordance with embodiments of the present disclosure.

[0010] FIG. 1E is a side view of a magnetically-coupled device in accordance with embodiments of the present disclosure.

[0011] FIG. 1F is a side view of a magnetically-coupled device in accordance with embodiments of the present disclosure.

[0012] FIG. 1G is a top view of the magnetically-coupled device of FIG. 1F in accordance with embodiments of the present disclosure.

[0013] FIG. 1H is a top view of a magnetically-coupled device in accordance with embodiments of the present disclosure.

[0014] FIG. 1I is a top view of a magnetically-coupled device in accordance with embodiments of the present disclosure.

[0015] FIG. 1J is a side view of a magnetically-coupled device in accordance with embodiments of the present disclosure.

[0016] FIG. 2A is a side view of a two-magnet magnetically-coupled device in accordance with embodiments of the present disclosure.

[0017] FIG. 2B is a top view of the magnetically-coupled device of FIG. 2A in accordance with embodiments of the present disclosure.

[0018] FIG. 2C is a top view of the magnetically-coupled device of FIG. 2A in operation in accordance with embodiments of the present disclosure.

[0019] FIG. 2D is a top view of the magnetically-coupled device of FIG. 2A in operation in accordance with embodiments of the present disclosure.

[0020] FIG. 2E is a top view of a three-magnet magnetically-coupled device in accordance with embodiments of the present disclosure.

[0021] FIG. 2F is a top view of the magnetically-coupled device of FIG. 2E in operation in a stressed state position in accordance with embodiments of the present disclosure.

[0022] FIG. 2G is a side view of a magnetically-coupled device in accordance with embodiments of the present disclosure.

[0023] FIG. 2H is a top view of the magnetically-coupled device of FIG. 2G in accordance with embodiments of the present disclosure.

[0024] FIG. 2I is a top view of the magnetically-coupled device of FIG. 2G in operation in accordance with embodiments of the present disclosure.

[0025] FIG. 2J is a side view of the magnetically-coupled device of FIG. 2G in operation in accordance with embodiments of the present disclosure.

[0026] FIG. 2K is a side view of a magnetically-coupled device in accordance with embodiments of the present disclosure.

[0027] FIG. 2L is a side view of a magnetically-coupled device in accordance with embodiments of the present disclosure.

[0028] FIG. 2M is a top view of the magnetically-coupled device of FIG. 2E in operation in a stressed state position in accordance with embodiments of the present disclosure.

[0029] FIG. 3A is a side view of a magnetically-coupled device in accordance with embodiments of the present disclosure.

[0030] FIG. 3B is a top view of the magnetically-coupled device of FIG. 3A in accordance with embodiments of the present disclosure.

[0031] FIG. 3C is a top view of the magnetically-coupled device of FIG. 3A in operation in accordance with embodiments of the present disclosure.

[0032] FIG. 3D is a side view of the magnetically-coupled device of FIG. 3A connected to a shaft in accordance with embodiments of the present disclosure.

[0033] FIG. 3E is a top view of a magnetically-coupled device in accordance with embodiments of the present disclosure.

[0034] FIG. 3F is a top view of the magnetically-coupled device of FIG. 3E in accordance with embodiments of the present disclosure.

[0035] FIG. 3G is a side cross-section view of a magnetically-coupled device in accordance with embodiments of the present disclosure.

[0036] FIG. 3H is a top view of the magnetically-coupled device of FIG. 3G in operation in accordance with embodiments of the present disclosure.

[0037] FIG. 3I is a top view of the magnetically-coupled device of FIG. 3G in accordance with embodiments of the present disclosure.

[0038] FIG. 3J is a side view of the magnetically-coupled device of FIG. 3G in accordance with embodiments of the present disclosure.

[0039] FIG. 4A is top view of a magnetically-coupled device in accordance with embodiments of the present disclosure.

[0040] FIG. 4B is a top view of a magnetically-coupled device in accordance with embodiments of the present disclosure.

[0041] FIG. 4C is a top exploded open clam-shell view of a magnetically-coupled device in accordance with embodiments of the present disclosure.

[0042] FIG. 4D is a side cut-away view of a portion of the magnetically-coupled device of FIG. 4C, in accordance with embodiments of the present disclosure.

[0043] FIG. 5A is a diagram of a plurality of magnetically-coupled devices in accordance with embodiments of the present disclosure.

[0044] FIG. 5B is a diagram of a plurality of magnetically-coupled devices in accordance with embodiments of the present disclosure.

[0045] FIG. 6 is a plot of experimental data obtained for a magnetically-coupled device in accordance with embodiments of the present disclosure.

[0046] FIG. 7A is a side view of the magnetically-coupled device embodiment with input and output shafts and no mechanical connection between the rotor and stator in accordance with embodiments of the present disclosure.

[0047] FIG. 7B is a side view of the magnetically-coupled device alternative embodiment with input and output shafts and no mechanical connection between the rotor and stator in accordance with embodiments of the present disclosure.

[0048] FIG. 7C is a side view of the magnetically-coupled device alternative embodiment with input and output shafts and no mechanical connection between the rotor and stator in accordance with embodiments of the present disclosure.

[0049] FIG. 7D is a side view of the magnetically-coupled device alternative embodiment with input and output shafts and no mechanical connection between the rotor and stator in accordance with embodiments of the present disclosure.

[0050] FIG. 8A is a top view of a magnetically-coupled device in accordance with embodiments of the present disclosure.

[0051] FIG. 8B is a top exploded open clam-shell view of the magnetically-coupled device of FIG. 8A in accordance with embodiments of the present disclosure.

[0052] FIG. 8C is a top view of a movable magnet of the magnetically-coupled device of FIG. 8A in accordance with embodiments of the present disclosure.

[0053] FIG. 8D is a top view of a magnetically-coupled device in accordance with embodiments of the present disclosure.

DETAILED DESCRIPTION

[0054] As discussed in more detail below, in some embodiments, the present disclosure is directed to systems and methods for a magnetically-coupled spring, a magnetic spring, a magnetically-coupled device (magnetic coupling), or a magnetically-coupled torque-assist device or module or apparatus, which uses high-energy permanent magnets arranged to form one or more movable magnets (or “rotor”), and a stationary set of magnets (or “stator”), and configured to use elastic properties of magnetic fields to provide a spring-like mechanical and energy storage properties. The rotor and stator magnets may be contained within or disposed on a variety of housings, platforms and structures. The stator may be attached to a stationary structure or a moving or rotating structure, such as a rotating shaft or moving platform or vehicle. In some embodiments, input angular force or torque is applied to an input shaft which is mechanically connected to the movable magnet or rotor, and the stator is mechanically connected to an output shaft. The magnetically-coupled device of the present disclosure may use permanent magnets of any shape and size, based on the desired design parameters. In some embodiments, the rotor and stator, when both are attached to rotating shafts, may be referred to respectively herein as a drive rotor (connected to an input applied force) and a load rotor (connected to a load), or vice versa.

[0055] In some embodiments, the magnetically-coupled device of the present disclosure utilizes the elastic effect of attractive and repulsive magnetic fields to operate by simultaneously applying tension to (or stretching or pulling on) attractive elastic magnetic field forces (created by opposite-polarity attraction, e.g., N-S or S-N) and applying compression to (or pushing on) elastic repulsive magnetic field forces (created by same-polarity repulsion, e.g., N-N or S-S) between the rotor and the stator, which may also be referred to herein collectively as a magnetic “dual-forces” or “tension-compression” or “attraction-repulsion” or “push-pull” arrangement.

[0056] As a result, in some embodiments, the rotor-stator combination may have various states or positions of operation, such as: (i) an equilibrium state position (ESP), where there is no external input force and the aggregate magnetic forces (attraction and repulsion) between the rotor and the stator magnets in the direction of rotor magnet movement or rotation sum to zero (or are balanced) and, thus, the rotor is stationary relative to the stator; (ii) an elastically stressed (or elastically altered or elastically deformed) state position (SSP), where an input force causes the rotor to move away from the ESP in the direction of rotor magnet movement (or rotation), and at least a portion of the attractive elastic magnetic field forces (or lines) are stretched (or pulled or

placed under tension) and at least a portion of the repulsive elastic magnetic field forces (on at least one side of the rotor magnet) are compressed (or pushed or placed under compression), which elastic forces collectively resist the movement of the rotor in such rotor magnet movement (or rotation) direction; and (iii) a decoupled state position (DSP), where the input force exceeds the aggregate (or total or resultant or net) attractive and repulsive elastic magnetic field forces resisting the rotor movement (or rotation), and the rotor becomes magnetically “decoupled” from the stator in the direction of rotor magnet motion (or rotation), and magnetically breaks-free (or releases or decouples) from the stator allowing the rotor to move (or rotate) freely, as discussed herein. In some embodiments, the rotor may also decouple from the stator in a direction perpendicular to the plane of motion or rotation of the rotor magnet.

[0057] In some embodiments, the gap between the rotor and stator magnets may be held substantially constant during rotor movement, or may vary based on the design performance requirements. In some embodiments, the elastic resistance or force/distance characteristics (or stiffness or spring constant K) may be substantially linearly, similar to the linear region conventional spring, or it may be partially linear over certain operating ranges, or may be non-linear, or a combination thereof, based on the design performance requirements. In some embodiments, the gap between adjacent stator magnets may be the same, or may vary based on design performance requirements. In some embodiments, in the case of multiple rotor magnets, the gap between adjacent rotor magnets may be the same, or may vary based on design performance requirements.

[0058] Thus, the present disclosure may be used as a “torque-limiter” (for angular motion), which will not allow the input torque (or an angular input force) applied to an input shaft to exceed a predetermined maximum torque value (e.g., the magnetic decoupling torque). If the input torque exceeds the decoupling torque, the rotor will magnetically decouple from the stator (and enter the DSP) and thereby limit the shaft torque. A similar approach may be used for linear or translational (non-circular) movement, e.g., where the stator and rotor are configured to move along a linear or non-circular path, which may be referred to as an “input force limiter” or “translational force limiter”.

[0059] The present disclosure also allows energy to be stored in the elastic state when the device is operating in the elastically stressed state position (SSP), similar to that of a conventional spring. Thus, the magnetically-coupled device of the present disclosure converts elastic potential energy to kinetic energy.

[0060] The magnetically-coupled device of the present disclosure may exhibit a linear force/distance response (based on known Hooke’s law) over a certain operating range, like a conventional spring, or may have multiple different linear spring constants and/or multiple different force/distance response profiles over its operating range, or have a non-linear force/distance response profile over its operating range, or may have a combination of linear and non-linear response profiles over its operating range. In particular, the spring constant (K) value, or force/distance response, or “stiffness”, of the magnetically-coupled at a given operating position may be determined by the gap distance between the rotor and stator magnets, the strength of the permanent magnets (or the aggregate magnetic field or flux strength of the magnets), the rotor and stator housing or

mounting structure material (e.g., a steel housing may enhance magnetic field strength), and other factors.

[0061] The magnetically-coupled device of the present disclosure does not experience material fatigue or breakage like a conventional spring or coil, as there is no elastic material strain creating the spring effect, only a magnetic field strain (e.g., tension and compression). Some embodiments of the present disclosure provide a rotor and stator that are mechanically separate from each other, which allows spring-like action with no mechanical interaction (or wear) between the rotor and stator. In some embodiments, the gap between the rotor and stator magnets may vary based on the state or condition, e.g., the rotor-stator gap may widen when an input force exceeds the magnetic decoupling force or torque, and, in some embodiments, the gap may automatically reset to its original position when the input force goes below the limit, thereby allowing the shaft to spin more freely when in the decoupled state.

[0062] Accordingly, the present disclosure retains certain beneficial features of conventional springs, while avoiding the non-beneficial ones, and also enabling other more advanced arrangements, as discussed more herein.

[0063] Referring to FIGS. 1A and 1B, a magnetically-coupled device 100A according to embodiments of the present disclosure is shown in a side view in FIG. 1A and from a top view in FIG. 1B. The device 100A includes a plurality of stationary (or stator) magnets 102A, 102B, 102C (collectively identified as 102) and a movable (or rotor) magnet 104. The stationary magnets 102 and movable magnet 104 are permanent magnets. The stationary magnets 102 are fixed or disposed in or on a surface or material 111 along a stationary magnet path 106. The movable magnet 104 is movable along a moving magnet path 108. The stationary magnets 102 alternate in magnetic polarity along the stationary magnet path 106.

[0064] The first stationary magnet 102A (left magnet in FIG. 1A) has south pole polarity S on the side 103A facing the movable magnet 104, the second stationary magnet 102B (middle magnet in FIG. 1A) has north pole polarity N on the side 103B facing the movable magnet 104 and the third stationary magnet 102C (right magnet in FIG. 1A) has south pole polarity on the side 103C facing the movable magnet 104. Also, the stationary magnets 102 each have opposite magnetic polarities on different sides of the respective magnets 102A, 102B, 102C. The movable magnet 104 also has opposite polarity on different sides of the magnet 104. The bottom side 105A of the movable magnet 104 facing the stationary magnets 102 has south pole polarity S and the top side 105B facing away from the stationary magnets 102 has north pole polarity N. Also, there is a horizontal distance (or gap) 120 between the left end surfaces of the movable magnet 104 and stationary magnet 102A and a horizontal distance 122 between the right end surfaces of the movable magnet 104 and the stationary magnet 102C which may be equal.

[0065] There are gaps 107A, 107B between the adjacent stationary magnets 102A, 102B, 102C along the stationary magnet path 106. The distances of the gaps 107A, 107B are equal between each adjacent stationary magnet 102; however, the distances of the gaps 107A, 107B may be unequal in order to configure the system in a particular manner as is later discussed herein in greater detail. There is a fixed gap 107C between the movable magnet 104 and the top surface 103A, 103B, 103C (collectively 103) level of the stationary

magnets **102**. In some embodiments, the gap **107C** is substantially zero (e.g. the surfaces may be touching or coated with a low friction coating, e.g. Teflon). In some embodiments, the gap **107C** is created by a material, structure or support (not shown) between the bottom surface of the movable magnet **104** and the top surface **103** of the stationary magnets **102**. The material or support surface may be substantially transparent to magnetic fields in order to minimize interference with magnetic forces between the magnetic fields of the magnets **102**, **104**. In some embodiments, the movable magnet **104** is mechanically held at the gap distance **107C** away from the stationary magnets **102A**, **102B**, **102C**, as discussed herein. In some embodiments, the gap **107C** may be variable or may change state/value in certain conditions.

[0066] In the device **100A**, there is a repulsive magnetic force **110** generated due to the matching polarity of the first stationary magnet **102A** and bottom side **105A** of the movable magnet **104** (south-south), an attractive magnetic force **112** due to the opposite polarities of the second stationary magnet **102B** and the bottom side **105A** of the movable magnet **104** (north-south) and a repulsive magnetic force **114** due to the matching polarity of the third stationary magnet **102C** and the bottom side **105A** of the movable magnet **104** (south-south). The position of the movable magnet **104** shown in FIGS. **1A** and **1B** may be considered an equilibrium state or equilibrium state position (ESP). In the equilibrium state, the sum of the horizontal forces acting on the movable magnet **104** are balanced (or zero) such that the movable magnet **104** is stationary.

[0067] Referring to FIG. **1C**, in operation, an applied force **AF** may be applied to the movable magnet **104** in a direction substantially parallel to the movable magnet path **108**. The applied force **AF** causes the movable magnet **104** to move a stress distance **116** from the equilibrium state position. In operation, the force applied to the movable magnet **104** may be solely in a direction that is parallel to the movable magnet path **108**. However, a vector component of a force applied in the direction that is substantially parallel to the movable magnet path **108** may be considered the applied force **AF**. The configuration of the magnetically-coupled device **100A** opposes the applied force **AF**. The horizontal component **110A** of the repulsive force **110** between the first stationary magnet **102A** and the movable magnet **104** increases as the movable magnet **104** moves (along the path **108**) towards the first stationary magnet **102A** due to “compression” of the matching (repelling) magnetic fields (i.e., the distance **120** between the first stationary magnet **102A** and the movable magnet **104** decreases). The magnetic fields of the magnets **102A**, **104** may be considered in a state of compression. Conversely, the horizontal component **112A** of the attractive force **112** between the second stationary magnet **102B** and the movable magnet **104** decreases slightly as the movable magnet **104** moves along the path **108** away from the second stationary magnet **102B** due to “tension” (or stretching) of the opposite (attracting) magnet fields (i.e., the gap between the second stationary magnet **102B** and the movable magnet **104** increases). In addition, the horizontal component of the repulsive force **114** between the third stationary magnet **102C** and the movable magnet **104** decreases as the movable magnet **104** moves along the path **108** away from the stationary magnet **102C** due to a decrease in compression of the matching magnetic fields **114**; since the distance **122** between the movable magnet **104** and the third stationary

magnet **102C** is greater at the stress distance position **116** than the effective gap at the equilibrium state position. The magnetically-coupled device **100A** may be considered to be in a “stressed” state or stressed state (or energy storage) position (SSP). In the stressed state, the horizontal component **110A** of the repulsive force **110** between the first stationary magnet **102A** and the movable magnet **104** is greater than the horizontal component **114A** of the repulsive force **114** between the third stationary magnet **102C** and the movable magnet **104**.

[0068] When the applied force **AF** is removed, the device **100A** will seek to return the movable magnet **104** to the equilibrium state position, i.e., the position shown in FIGS. **1A** and **1B**. The device **100A** will seek to achieve the equilibrium state because the sum of the horizontal components of the magnetic forces **110A**, **112A**, **114A** on the movable magnet **104** is not equal (or zero). In particular, the horizontal components of the repulsive force **110A** between the first stationary magnet **102A** and the movable magnet **104** in addition to the horizontal component of the attractive force **112A** between the second stationary magnet **102B** and the movable magnet **104** is greater than the horizontal component of the repulsive force **114A** between the third stationary magnet **102C** and the movable magnet **104**. Similarly, when the applied force **AF** is decreased in strength, the movable magnet **104** will move along the path **108** in the direction of the equilibrium state position until the sum of the horizontal components of the forces **110A**, **112A**, **114A** on the movable magnet **104** are equal to zero (i.e. the forces are balanced).

[0069] As shown in FIG. **1D**, the applied force **AF** could also be applied in the opposite direction from the direction shown in FIG. **1C**, but still substantially parallel to the direction of the movable magnet path **108**. The position of the movable magnet **104** is shown in another stressed state in which the device **100A** will seek to achieve the equilibrium state when the applied force **AF** is removed. Similarly, when the applied force **AF** is decreased in strength, the movable magnet **104** will move along the path **108** in the direction of the equilibrium state position until the sum of the horizontal components of the forces **110A**, **112A**, **114A** on the movable magnet **104** are equal to zero (i.e. the forces are balanced).

[0070] It should be readily understood that the repulsive magnetic forces **110**, **114** and the magnetic attractive force **112** can be selectively configured by choosing the appropriate magnet strength of each permanent magnet **102A**, **102B**, **102C**, **104**. Further, the magnet forces **110**, **112**, **114** can be selectively configured by adjusting the distances of the gaps **107A**, **107B**, **107C**, **120**, **122**. The gaps **107A**, **107B**, **107C**, **120**, **122** may be permanently fixed or adjustable through known magnet gap adjustment mechanisms. The gaps **107A**, **107B**, **107C**, **120**, **122** may also be adjusted to be unequal distances so that the movable magnet **104** is more easily forced in one direction over the opposite direction if desired. The particular configuration of the magnets **102**, **104** and gaps **107A**, **107B**, **107C**, **120**, **122** between magnets **102**, **104** allows for the magnetic forces **110**, **112**, **114** to be selectively chosen in order to determine an overall spring constant (**K**) (e.g. distance/force applied; Hooke’s law) for the magnetically-coupled device and/or spring constants between different equilibrium state positions within the magnetically-coupled device. The mass of the movable magnet **104** and/or a mass (or masses) attached to the

movable magnet **104** may also contribute to the overall spring constant of the magnetically-coupled device **100A**.

[0071] While the movable magnet **104** is shown as having a larger diameter than that of the stationary magnets **102** in the direction of the stationary magnet path **106** and/or movable magnet path **108**, it should be readily understood that in some embodiments the movable magnet **104** may be the same size or smaller than the stationary magnets **102**.

[0072] Referring to FIG. 1E, a magnetically-coupled device **100B** is shown that is substantially the same as the magnetically-coupled device **100A** shown in FIG. 1A except that the magnetically-coupled device **100B** comprises seven (7) stationary magnets **102** instead of three (3). In the magnetically-coupled device **100B**, the additional stationary magnets **102** allows for the movable magnet **104** to be moved to more than one equilibrium state. If the applied force AF (FIG. 1C) and the repulsive force **110A** is great enough to overcome the attractive magnetic force **112A** and the repulsive magnetic force **114A**, the movable magnet can magnetically “break” or “decouple” from the magnet device seeking to return to the first equilibrium state position ESP₁, and instead seek to achieve an equilibrium state at the second or third equilibrium state positions ESP₂, ESP₃. Advantageously, the magnetic device **100B** magnetically “breaking” or “decoupling” from seeking one equilibrium state to another equilibrium state does not cause any damage to the magnetically-coupled device **100B** components. As discussed above, the magnetic force strength between the rotor and stator magnets can be selectively configured, which allows for the force required to magnetically break or decouple from one equilibrium state position ESP₁, ESP₂, ESP₃ to another equilibrium state position ESP₁, ESP₂, ESP₃ to be selectively configured. It should be understood that magnetically-coupled devices according to the present disclosure may have any number of a plurality of stationary magnets **102** and/or equilibrium state positions ESP.

[0073] In some embodiments, the magnetically-coupled device **100B** may be configured such that the rotor-stator gap **107C** between the movable magnet **104** and the stationary magnets **102** is adjusted when the movable magnet **104** breaks from seeking an equilibrium state position and may be referred to herein as the Decoupled State or Decoupled State Position (DSP). In some embodiments, the gap **107C** increases to a sufficiently large degree so that the movable magnet **104** does not seek a new equilibrium state. The magnetically-coupled device **100B** may be connected to a mechanism or controller that provides an indication to a user when the magnetically-coupled device **100B** breaks (is in the DSP) and the rotor-stator gap **107C** is adjusted, or be operatively connected to a mechanism or controller that turns on or turns off a device or operation if the magnetically-coupled device **100B** indicates a breaking condition occurred. In such embodiments, the movable magnet **104** may advantageously function as a re-usable shear pin. Since the movable magnet **104** can be reset after reaching the DSP, an operator of a device having a magnetically-coupled device **100B** can adjust the movable magnet **104** back to an operational position where the movable magnet **104** seeks an equilibrium state position, i.e., return the movable (or rotor) magnet **104** to a position where the rotor-stator gap **107C** is substantially the same as it was prior to the decoupling condition.

[0074] It should be readily understood that in embodiments according to the present disclosure, the movable

magnet **104** may not move along an exactly linear movable magnet path **108**. In some embodiments, the movable magnet **104** may be configured to move along a non-linear path, such as, for example and without limitation, an arc path or serpentine, or other non-linear path.

[0075] Referring to FIGS. 1F and 1G, a magnetically-coupled device **100C** is shown from a side view in FIG. 1F and from top view in FIG. 1G. The magnetically-coupled device **100C** is substantially similar to the magnetically-coupled devices **100A**, **100B** discussed above. However, in the magnetically-coupled device **100C**, the stationary magnets **102** are arranged along a circular stationary magnet path **106A** and, likewise, the movable magnet **104** is configured to move along a matching circular movable magnet path **108A**. Otherwise, the function and operation of the magnetically-coupled device **100C** is substantially the same. The movable magnet **104** can magnetically “break” or “decouple” between different equilibrium state positions when a horizontal applied force AF is applied to the movable magnet **104**, thereby moving the magnet in a clockwise or counterclockwise direction along the circular path **108A** of the movable rotor magnet **104**.

[0076] A magnetically-coupled device **100D** is shown from a top view in FIG. 1H. The magnetically-coupled device **100D** is substantially similar to the magnetically-coupled devices **100A**, **100B**, **100C** discussed above. The magnetically-coupled device **100D** is similar to the device **100C** shown in FIGS. 1F and 1G in the respect that the stationary magnets **102** are arranged along the circular stationary magnet path **106A** and, likewise, the movable magnet **104** is configured to move along a circular movable magnet path **108A** and have arm **151** attached to the shaft **150**. However, instead of the rotor magnet **104** (and the rotor path **108A**) being on top of the stator magnets **102** (and the stator magnet path **106A**), in this case, the circular path **108A** of the rotor magnets **104** is located concentrically inside the circular path **106A** of the stator magnets **102**. Otherwise, the function and operation of the magnetically-coupled device **100D** is substantially the same. The movable magnet **104** can magnetically “break” or “decouple” between different equilibrium state positions ESP when an applied force AF (or rotational input torque) is applied to the side of the movable rotor magnet **104**, thereby moving the rotor magnet **104** in a clockwise or counterclockwise direction along the circular movable rotor magnet path **108A**.

[0077] A magnetically-coupled device **100E** is shown from a top view in FIG. 1I. The magnetically-coupled device **100E** is substantially similar to the magnetically-coupled devices **100A**, **100B**, **100C**, **100D** discussed above. The magnetically-coupled device **100E** is similar to the device **100D** shown in FIG. 1H in the respect that the stationary (stator) magnets **102** are arranged along circular stationary (stator) magnet path **106** and, likewise, the movable (rotor) magnet **104** is configured to move along a circular movable magnet path **108**. However, in this case, the stationary magnets **102** are disposed on a structure (e.g., disc or plate or circular cylindrical casing or housing). Otherwise, the function and operation of the magnetically-coupled device **100E** is the same. The movable magnet **104** can magnetically “break” or “decouple” between different equilibrium state positions ESPs, when a rotational applied force AF is applied to the side of the movable magnet **104**, thereby

moving the rotor magnet **104** in a clockwise or counter-clockwise direction along the circular movable (rotor) magnet path **108A**.

[0078] Referring to FIG. 1J, while the equilibrium state positions of magnetically-coupled devices have been shown and described as having a movable magnet **104**, which is movable with respect to three stationary magnets **102**, it should be readily understood that the same principles and applications may be used for a magnetically-coupled device having only two stationary magnets, or two (or more) stationary magnets for each equilibrium state position. In particular, a magnetically-coupled device **100F** is shown in FIG. 1J that is substantially the same as the magnetically-coupled device **100A** of FIGS. 1A and 1B. However, the magnetically-coupled device **100F** includes only two stationary magnets **102A**, **102B**.

[0079] Referring to FIG. 1J, magnetically-coupled devices described herein may also be used in applications where an applied force AF is primarily only in one direction and which primarily operates in the ESP and SSP positions. For instance, the magnetically-coupled device **100F** may be configured to receive the applied force AF in the direction of the rotor movement path **108** from right to left and in the direction of the stationary (or stator) magnet **102A**, causing the repulsive force **110**, i.e., in a direction that pushes the movable magnet **104** away from the first stator magnet **102A** and towards the second stator magnet **102B** to be compressed, and the attractive force **112** between the rotor magnet **104** and the stator magnet **102B** to be stretched or in tension (or be in the stressed state position SSP), the magnet **102** having an upper surface **103A** (FIG. 1A) providing the repulsive force **110** with the same magnetic polarity as the bottom surface **105A** (FIG. 1A) of the movable magnet. Conversely, when the applied force AF is removed or reduced the rotor magnet **104** will move back toward the ESP, as described herein with the device **100A** (FIG. 1A).

[0080] In embodiments according to the present disclosure, the magnetically-coupled devices may be used in an application where the movable magnet **104** is connected to a shaft **150** by an arm **151**, the shaft **150** being rotatable about a shaft axis extending in a longitudinal direction of the shaft **150**. In some embodiments, the shaft **150** may be connected to one side of a bearing **156**, and the other side of the bearing **156** is connected to the structure **111A** supporting the stationary magnets **102**. For example, the magnetically-coupled devices **100C** (FIGS. 1F and 1G), **100D** (FIG. 1H) can convert the mechanical kinetic energy provided by rotation **154** of the shaft **150** into potential energy of the magnetically-coupled device **100C**, **100D** being actuated (or rotated or torqued) to the elastically stressed state position (SSP) discussed herein. The magnetically-coupled device **100C**, **100D** converts the elastic potential energy back to mechanical kinetic energy when the movable magnet **104** through arm **152** is brought back to an equilibrium state position, which thereby provides shaft **150** rotation **154**, i.e., kinetic energy. While the movable magnet **104** is shown as being connected to the shaft **150** by an arm **152**, it should be readily understood that the arm **152** may be fixed to the shaft **150** through any known connection structures. In some embodiments, instead of the arm **152** the stationary or stator magnets **102** may be attached or disposed on or in a plate or disc or a cylinder that rotates with shaft rotation. The embodiments of FIGS. 1F and 1G may be cylindrical magnets for both the stationary magnets (or “stator”) **102**

and the movable magnet (or “rotor”) **104** and may use cylindrical “end face” forces between the rotor **104** and the stator **102**.

[0081] It should be readily understood that there may be a plurality of movable (or rotor) magnets **104** in a magnetically-coupled device **100** according to the present disclosure. For example, in the magnetically-coupled devices **100C**, **100D** there may be an arm **152** for each movable magnet **104**. In the magnetically-coupled device **100E** (FIG. 1I), there may be multiple movable magnets **104** arranged about the shaft **150**. In the embodiments where there are a plurality of movable magnets **104**, the movable magnets **104** may be spaced from each other at each equilibrium state position ESP such that the movable magnets **104** may simultaneously be in equilibrium state positions. In some embodiments, there may be a movable magnet **104** for each possible equilibrium state position ESP.

[0082] Referring to FIGS. 2A and 2B, a magnetically-coupled device **200A** using diametrically magnetized cylindrical stator and rotor magnets and angular “side-shear” force between the rotor magnet and the stator magnet is shown from a side view in FIG. 2A and from a top view in FIG. 2B. The device **200A** includes a single stationary magnet (or stator) **202A** and a movable magnet (or rotor) **204**. The stationary magnet **202A** and movable magnet **204** are permanent magnets. The stationary magnet **202A** is arranged on a plane **206** such that the stationary magnet **202A** has north pole polarity on one side **203B** of the plane **206** (left side in FIG. 2A view) and south pole polarity on the opposite side **203A** of the plane **206** (right side in FIG. 2A) facing the rotor **204**. The rotor **204** is separated from the stator **202A** by a rotor-stator gap **207A**.

[0083] The rotor **204** is configured to move or rotate **209** (FIG. 2B) about a movable magnet axis (or rotor axis) **208** in either direction. The rotor **204** has one side **205A** having north pole N polarity (left side in FIG. 2A) and a second opposite side **205B** having south pole S polarity (right side in FIG. 2A).

[0084] In the device **200A**, there is an attractive force **212** generated due to the opposite polarities of the stator **202A** side **203A** (south) facing the rotor **204** and the rotor **204** side **205A** (north) facing the stator **202A**. The position of the movable magnet **204** shown in FIGS. 2A and 2B may be considered an equilibrium state or equilibrium state position (ESP). In the equilibrium state, the sum of the forces acting on the rotor **204** are zero such that the rotor **204** remains stationary, i.e., the sum of the forces in a rotational direction **209** about the movable magnet axis **208** are zero.

[0085] There may be a center rotor shaft **220** (or input shaft), which receives input force or input torque, is attached to the movable rotor magnet **204**, such that when the input shaft **209** is rotated **209** by an input force or torque, the rotor magnet **204** also turns. The rotor shaft **220** passes through the housing via a flange bearing, e.g., a Cleveland Freeway sealed flanged shaft ball-bearing, e.g., having an outer diameter (OD) of about 1.5 inches, an inner diameter (ID) of about $\frac{5}{8}$ inches, and a thickness of about $\frac{7}{16}$ inches, which provides ease of rotation (low friction) and lateral support for the rotor shaft **220**. Other dimensions and bearing types may be used if desired. Instead of a bearing, a bushing or cylindrical lining may be used to provide low friction and low wear inside the hole that the input rotor shaft **220** passes through. The bushing may use a bronze liner, plastic liner, O-Ring, Teflon® coating, or the like, to provide desired

low-friction rotation. Other structural components may be used to provide ease of rotation (low friction rotation) and lateral support for the input rotor shaft **220** if desired. The input shaft **220** may have a diameter of about $\frac{5}{8}$ inches and may be threaded, and may have a $\frac{1}{4}$ inch threaded center hole to receive a $\frac{1}{4}$ inch-20 bolt (rotor bolt), which passes through the bottom of the housing and through the center of the rotor magnet **204** to attach the rotor to the rotor **204** shaft **220** and to provide more lateral support for the rotor magnet and a rotational axis around which the rotor magnet **204** may rotate. The cylindrical magnets **202A**, **204** may each have a longitudinal hole along the length of the cylinder which may be used to receive the $\frac{1}{4}$ " vertical bolts (stator bolt and rotor bolt) used to hold the magnets **202A**, **204**, respectively, in place laterally (horizontally) and/or to allow the rotor magnet **204** to rotate about the vertical rotational axis **208**. In this case, the stator magnet **202A** would be fixed in position (laterally, vertically and rotationally) and the rotor magnet **204** would be fixed in position laterally (horizontally) and vertically, and allowed to rotate as indicated by the arrows **209** (as described herein) about the vertical rotor axis **208** and rotor bolt through the center of the rotor magnet **204**.

[0086] Also, there may be a washer or spacer or locking nuts underneath the rotor magnet **204** and on the $\frac{1}{4}$ " rotor bolt, between the bottom of the rotor magnet **204** and the housing bottom, that allows the rotor to spin or rotate **209** about the vertical axis **208**. Also, there may also be a washer or spacer underneath the stator magnet **102** and on the $\frac{1}{4}$ " stator bolt, between the bottom of the stator magnet **102** and the housing bottom, which allows the stator to be vertically positioned at substantially the same height as the rotor magnet.

[0087] An output shaft **220A** may be connected to the bottom plate of the housing, to which an output energy receiver (e.g., alternator or the like) may be connected. The bottom housing plate may have a mounting flange, e.g., a pipe hanger flange, having a threaded socket, e.g., an M16-1.5 (metric-thread pitch), into which the output shaft **220A** is threaded into.

[0088] The housing may be made of a ferrous material, e.g., steel, or other ferrous material that conducts magnetic fields. Using a steel housing for embodiments described herein provides at least two benefits, including: (1) limits flux leakage outside the housing to nearby environment, acting like a magnetic field shield; and (2) acts as a flux conductor or "keeper", which magnifies the maximum magnetic flux of the magnet to be about $\frac{1}{3}$ stronger than the magnet rating in the face of the magnet opposite the housing plate, by focusing the magnetic field.

[0089] Also, the cylindrical magnets may be Grade N42 Neodymium, diametrically magnetized cylindrical (or disc) magnets, made by K&J Magnetics, Part No. RX04X0DIA, having about 1 inch OD, about $\frac{1}{4}$ inch ID, and about 1 inch long (or thick). Also, the air gap between the cylindrical magnets may be about $\frac{1}{10}$ inch airgap. Other dimensions and shapes may be used if desired depending on the design requirements. As discussed herein, the cylindrical magnets described herein may have longitudinal holes (e.g., about $\frac{1}{4}$ " diameter) along the length of the cylinders, which may be used to receive bolts to hold the magnets in place, to attach them to a plate or housing, and/or to allow the magnet to rotate around (rotational axis). Other air gaps may be used if desired. Instead of bolts, the stator magnets may be glued

to or embedded into the housing or plates to secure the magnets to the housing or plates if desired.

[0090] Referring to FIG. 2C, in operation, rotational applied force AF is applied to the movable magnet **204** in the rotational direction **209** about the movable magnet axis **208**, which causes the movable magnet **204** to rotate by a predetermined angle **215** about the movable magnet axis **208**. In FIG. 2C, the applied force AF is in a counterclockwise direction **209A** about the movable magnet axis **208**. The applied force AF may be provided by the input shaft **220** (FIG. 2A) connected to the movable magnet **204**. When rotated as shown in FIG. 2C, the configuration of the magnetically-coupled device **200A** opposes the rotational applied force AF. The attractive force **212** between the opposite polarity sides **203A**, **205A** of the stationary magnet **202A** and the movable magnet **204** respectively, is put in tension and seeks to resist or counteract the rotation of the movable magnet **204** from the equilibrium state position (ESP). In addition, simultaneously, there is a repulsive force **210** between the south side **203A** of the stator magnet **202** and the south side **205B** of the rotor magnet **204**, which is put in compression and also acts to resist or counteract the rotation of the rotor magnet **204**, as the device is in the elastically stressed state position (SSP), as described herein.

[0091] Referring to FIG. 2D, as the movable (rotor) magnet **204** rotates further (and the angle **215** approaches 180 degrees), the side **205B** having south pole S polarity is brought closer to the matching south pole S polarity side **203A** of the stationary magnet **202A**, which generates a stronger repulsive force **210** as the repulsive force **210** is compressed, while the attractive force **212** is put in greater tension and decreases. The magnetically-coupled device **200A** in FIG. 2D may also be considered in the elastically stressed state or the elastically stressed state position (SSP).

[0092] When the applied force AF is removed (or decreased in strength), the device **200A** will seek to (or be biased to or attempt to) return the movable magnet **204** to the equilibrium state position (ESP), i.e., the position shown in FIGS. 2A and 2B. The sum of the repulsive force **210** and attractive force **212** is great enough to overcome any frictional opposing forces present in the rotational configuration of the movable magnet **204**.

[0093] Similar to the magnetically-coupled devices **100A**, **100B**, **100C**, the magnetic device **200A** would function substantially the same when the applied force AF is applied in the opposite direction, i.e., a clockwise direction. The repulsive force **210** and attractive force **212** would similarly seek to return the movable magnet **204** to the equilibrium state position (ESP).

[0094] Similar to the magnetic device **100B**, if the applied force AF were great enough to overcome the repulsive force **210** and attractive force **212**, the movable magnet **204** can magnetically "break" or "de-couple" such that the movable magnet **204** rotates about the movable magnet axis **208** until it recouples and seeks to return to the ESP by rotating a full revolution(s) (e.g. 360°, 720°, etc.). Thus, even when the movable magnet **204** de-couples, the magnetically-coupled device **200A** will seek to return the movable magnet **204** to the equilibrium state position. Advantageously, the movable magnet **204** may rotate any number of times in either direction of the rotational direction **209**. In other words, the movable magnet may move 360° or more in a first rotational direction **209A** (counterclockwise) and/or 360° or more in a second rotational direction **209B** (clockwise).

[0095] A difference between the magnetically-coupled device 100B shown in FIG. 1E and the magnetically-coupled device shown in FIGS. 2A-2D is that when the movable magnet 104 of the device 100B de-couples, the movable (rotor) magnet will move to an equilibrium state position (ESP) that is in a spatially different location from the starting equilibrium state position (i.e., the center of the movable magnet translates or moves or changes physical location when in motion). In contrast, when the movable magnet 204 of the device 200A de-couples, center of the movable magnet does not translate or moves or changes physical location as it rotates about its axis when in motion, and thus the movable magnet will return to the equilibrium state position (EPS) that is spatially the same location since the movable magnet 204 rotates about the movable magnet axis 208. Advantageously, as with the other embodiments, the movable magnet 204 may decouple any number of times without damaging the magnetically-coupled device 200A.

[0096] Similar to the magnetically-coupled devices 100A, 100B discussed above, it should be readily understood that the repulsive magnetic force 210 and the magnetic attractive force 212 can be selectively configured by choosing the appropriate magnet strength of each permanent magnet 202, 204. Further, the magnet forces 210, 212 can be selectively configured by adjusting the distances of the gap 207A. The rotor-stator gap 207A may be permanently fixed or adjustable through known magnet gap adjustment mechanisms.

[0097] Referring to FIG. 2E, a top view of a magnetically-coupled device 200B is shown in accordance with embodiments of the present disclosure. The magnetically-coupled device 200B is substantially the same as the magnetically-coupled device 200A of FIG. 2A except that it includes an additional stator magnet 202B. In particular, the first stationary (or stator) magnet 202A is arranged on a first plane 206A such that the first stationary magnet 202A has a north pole polarity on one side 203B of the first plane 206A (left side in FIG. 2E) and south pole polarity on the opposite side 203A of the first plane 206A facing the rotor 204. In addition, the magnetically-coupled device 200B of FIG. 2E includes the additional stationary (or stator) magnet 202B arranged on the opposite side of the rotor magnet 204 from the first stator magnet 202A. The additional stator magnet 202B is arranged on a second plane 206B such that the second stationary magnet 202B has a north pole polarity on one side 203B facing the rotor 204 (left side in FIG. 2E) and south pole polarity on the opposite side 203A of the second plane 206B. The second stator magnet 202B is arranged to have the same rotor-stator gap distance as the first gap 207A to provide symmetrical forces on the rotor. Different rotor-stator gap distances may be used if desired to adjust or use different aggregate forces if desired, depending on the design requirements.

[0098] Referring to FIG. 2F and FIG. 2M, in operation, rotational force AF is applied to the movable magnet 204 in the rotational direction 209. The operation of the magnetically-coupled device 200B is substantially the same as the operation of the magnetically-coupled device 200A discussed above in connection with FIGS. 2C and 2D. A difference is that the magnetically-coupled device 200B has an additional repulsive magnetic force 210B and an additional attractive force 212B due to the additional stationary (stator) magnet 202B, which would increase the magnetic forces on the rotor 204 (which resist rotor rotation) and thus make the magnetically-coupled device more “stiff” than that

of FIGS. 2C and 2D (using the same magnets and gaps). Also, the structural support and connection to the housing for the second stator magnet may be the same as that shown in FIG. 2A for the first stator magnet 202A, but located on the right side of the rotor 204.

[0099] Referring to FIG. 2G, a side view of a magnetically-coupled device 200C is shown in accordance with embodiments of the present disclosure. The magnetically-coupled device 200C includes a first movable magnet 204A and a second movable magnet 204B. The first movable magnet 204 is arranged or disposed on a structure 211. The first movable magnet 204A is separated from the second movable magnet 204B by a spacer 201, which provides a rotor-stator gap 207 equal to the spacer 201 height. The first movable magnet 204A is connected to a shaft 220 and is configured to rotate with the shaft 220 about a movable magnet axis 208 in either direction in a rotational direction 209. The second movable magnet 204B is arranged to move in a sliding direction 217 parallel to the movable magnet axis 208. The shaft 220 extends through the second movable magnet 204B, through the spacer 201 and into the first movable magnet 204A. The shaft 220 also extends through a stop element or plate 213 arranged above the second movable magnet 204B.

[0100] Referring to FIG. 2H, a top view of the magnetically-coupled device 200C is shown with the stop element 213 removed. The first movable magnet 204A is diametrically magnetized (i.e., magnetized through the diameter) such that the end of the first movable magnet 204A facing the second movable magnet 204B has a south pole S polarity side 205A and a north pole N polarity side 205B. The second movable magnet 204B is also diametrically magnetized and has a north pole N polarity side 205C and a south pole S polarity side 205D. As shown in FIG. 2H, the magnetically-coupled device 200C is in an equilibrium state position (ESP) where the opposite polarity (N-S, S-N) (attracting) sides of the movable magnets 204A, 204B are closest to each other.

[0101] Referring to FIG. 2I and FIG. 2J, in operation, when a clockwise rotational applied force 209 AF is applied (counterclockwise in FIG. 2I) to the shaft 220 and/or the first movable magnet 204A, the first movable magnet 204A rotates relative to the second movable magnet 204B. The second movable magnet 204B will experience repulsive magnet forces 210 and attractive magnet forces 212 that are compressed and in tension, respectively, as discussed above in connection with other embodiments, e.g., the magnetically-coupled device 200A of FIG. 2A. Thus, the second movable magnet 204B will seek the equilibrium state position (ESP) when the applied force AF 209 is removed or decreased in strength, as discussed herein.

[0102] Referring to FIG. 2J, during operation, when the movable magnet 204 rotates to a certain extent, the matching (opposing) polarity sides of the second movable magnet 204B will be close enough to force the second movable magnet 204B away from the first movable magnet 204A in the sliding direction 217 until the second movable magnet 204B comes to rest on the stop element 213, thereby increasing the gap (or distance) 207 between the first movable magnet 204A and the second movable magnet 204B. Thus, the first and second movable magnets are in a decoupled state position (DSP). After further rotation of the first movable magnet 204A, the repulsive (or opposing) magnetic force 210 will decrease and/or the attractive force

212 will increase such that the second movable magnet 204B is brought back to rest on the spacer 201 at the equilibrium state position (ESP).

[0103] In the embodiment of FIG. 2G, the first movable magnet 204A is shown as being larger in width (horizontal direction in FIG. 2G) than the second movable magnet 204B. In some embodiments, the first movable magnet 204A is the same size as the second movable magnet 204B or smaller than the second movable magnet 204B. In some embodiments, there may be no stop element 213, in which case the second movable magnet 204B will be forced away from the first movable magnet 204A until the sum of the repulsive magnetic force 210 and the force due to gravity is zero (or if the device is arranged in a direction perpendicular to the force of gravity, until the repulsive magnetic force 210 is unable to overcome the frictional force(s) resisting the sliding movement of the second movable magnet 204B).

[0104] It should be readily understood that the magnetically-coupled device 200C of FIG. 2G can be configured in many different ways. For example, and without limitation, in some embodiments the first movable magnet 204A could be arranged to rotate with the shaft 220 rotation and the second movable magnet 204B instead be configured as a stationary (stator) magnet and, thus, during operation the first movable magnet 204A would rotate and move in the sliding direction 217 (in such embodiments the shaft 220 may be configured to displace in the sliding direction 217 with the first movable magnet 204A as well). In some embodiments, the magnetically-coupled device 200C could be configured so that the second movable magnet 204B rotates and/or slides in the sliding direction 217 and the first movable magnet 204A is configured as a stationary (stator) magnet. In some embodiments, the maximum (and/or minimum) gap 207 between the magnets 204A, 204B is set by a locking element (e.g., dual locking bolts) connected to (or threaded on) the shaft 220 and arranged on the opposite side of the stop element 213 from the magnets 204A, 204B. Also, instead of the spacer there may be a locking elements to set the minimum gap 207.

[0105] Referring to FIG. 2K, a side view of a magnetically-coupled device 200D is shown from a side view according to embodiments of the present disclosure. The magnetically-coupled device 200D includes four stationary magnets (or stator magnets), a first stationary magnet 202A, a second stationary 202B, a third stationary magnet 202C and a fourth stationary magnet 202D (collectively 202) and a movable magnet (or rotor) 204. The rotor 204 is configured to rotate about a movable magnet axis (or rotor axis) 208 in a rotational direction 209. The first stationary magnet 202A and the second stationary magnet 202B are arranged on opposite sides of the movable magnet 204 in a direction perpendicular to the movable magnet axis 208. The third stationary magnet 202C and the fourth stationary magnet 202D are arranged on opposite sides of the movable magnet 204 in a direction parallel to the movable magnet axis 208 and, thus, the third and fourth stationary magnets 202C, 202D may be considered “basal” (or base) magnets. This arrangement of the magnetically-coupled device 200D lends itself well for both full rotational and partial angular displacement of the movable magnet 204. The magnets may be diametrically cylindrical magnets also having inner and outer concentrically magnetized regions, thus, there are two different dimensions of magnetic interactions in this embodiment. In some embodiments, the magnets may be

diametrically cylindrical magnets like that used in FIG. 2A without concentrically magnetized regions.

[0106] In operation, when the movable magnet 204 is rotated about the movable magnet axis 208 due to an applied force applied to the movable magnet or to a shaft which the movable magnet 204 is connected with, the movable magnet 204 will experience repulsive (or opposing) magnetic forces and attractive forces due to the matching (opposing) and opposite (attracting) magnetic field sides of the magnets as discussed above in connection with the embodiments of FIGS. 2A-2J. As shown in FIG. 2K, the movable magnet 204 is in an equilibrium state position (ESP). When in a stressed state position (SSP) due to rotation about the movable magnet axis 208, the movable magnet 204 will seek to return to the equilibrium state position (ESP) due to the repulsive magnetic forces in the direction of movement (being under compression) and the attractive magnetic forces (being under tension) according to principles as discussed above. The movable magnet 204 can rotate in either direction in the rotation direction 209 about the movable magnet axis 208, and can rotate any number times, i.e., the movable magnet 204 can break or decouple from the equilibrium state position (ESP) any number of times and return to the equilibrium state position (ESP) without any damage or deformation of components.

[0107] Referring to FIG. 2L, a magnetically-coupled device 200E is shown from a side view according to embodiments of the present disclosure. The magnetically-coupled device 200E is similar to the magnetically-coupled device 200B of FIG. 2E and the magnetically-coupled device 200C of FIG. 2G. The magnetically-coupled device 200E includes three stationary magnets; a first stationary magnet 202A, a second stationary magnet 202B, and a third stationary magnet 202C. The magnetically-coupled device 200E further includes a movable magnet 204 configured to rotate about a magnet axis (or rotor axis) 208 in a rotational direction 209 with a shaft 220. The movable magnet 204 defines a shaft receiving geometry 218 which is configured to receive a corresponding shaft protrusion geometry 219 therein. The shaft receiving geometry 218 and shaft protrusion geometry 219 ensure that the movable magnet 204 rotates with the shaft 220.

[0108] The first stationary magnet 202A and second stationary magnet 202B are configured on opposite sides of the movable magnet 204 in a radial direction from the shaft 220. The third stationary magnet 202C or basal magnet is arranged on a side (or end-face of the cylinder) of the movable magnet 204 in an axial direction of the shaft 220. The shaft 220 extends through and rotates within the third stationary magnet 202C, but the third stationary magnet does not rotate with the shaft 220. The magnetically-coupled device 200E is shown in an equilibrium state position (ESP) as shown in FIG. 2L.

[0109] The operation of the magnetically-coupled device 200E in FIG. 2L is similar to the operation of the magnetically-coupled device 200B of FIG. 2E and the magnetically-coupled device 200C of FIG. 2G. When the movable magnet 204 rotates in the rotational direction 209, the tension of the attractive magnetic forces and compression of the opposing magnetic forces (as discussed herein in connection with other embodiments) act on the movable magnet 204 such that the device 200E is in a stressed state position (SSP) and will seek to return the movable magnet 204 to the equilibrium state position (ESP). If the movable magnet 204 is

rotated enough about the magnet axis **208** the device will be in the decoupled state position (DSP), and the opposing magnetic forces caused by the same polarity (N-N; S-S) acting on the respective sides of the movable cylindrical magnet **204** will force the movable magnet **204** away from the third stationary magnet **202C** in an axial direction of the shaft **220** (as shown by up arrows) to a displaced position (or new position). The broken lines **204A** show a possible displaced position of the movable magnet **204**. The movable magnet **204** can be displaced until the movable magnet **204** rests against a stop element **219** (as discussed above) or until the sum of the magnetic forces are balanced with the force due to gravity if the magnetically-coupled device **200E** is arranged vertically.

[0110] Referring to FIGS. **3A** and **3B**, a magnetically-coupled device **300A** using a rotational rectangular magnet, according to embodiments of the present disclosure, is shown from a side view in FIG. **3A** and FIG. **3D**, and from a top view in FIG. **3B**. The device **300A** includes a plurality of rectangular stationary magnets **302A**, **302B**, **302C** (collectively identified as **302**) and a rectangular movable magnet **304** having a length **L** substantially the same length as the three stationary magnets **302A**, **302B**, **302C**. The stationary magnets **302** and movable magnet **304** are permanent magnets (described more hereinafter). The stationary magnets **302** are fixed in or on a surface or material **321** along a stationary magnet line or path **306** from a side view and along a line **306** (FIG. **3B**) from a top view. The movable magnet **304** is rotatable about a moving magnet axis (or rotor axis) **308**. The stationary magnets **302** alternate in magnetic polarity (e.g. N, S, N upper half; S, 1V, Slower half) along the stationary magnet path **306**.

[0111] The first stationary magnet **302A** (left magnet in FIG. **3A**) has north pole N polarity on a surface side **303A** facing the movable magnet **304**, the second stationary magnet **302B** (middle magnet in FIG. **3A**) has south pole S polarity on the side **303B** facing the movable magnet **304** and the third stationary magnet **302C** (right magnet in FIG. **3A**) has south pole S polarity on the side **303C** facing the movable magnet **304** (similar to the magnet **302A**). The movable magnet **304** has opposite polarity on different sides of the magnet **304**. The bottom side **305A** of the movable magnet **304** facing the stationary magnets **302** has south pole S polarity along its length **L** and the top side **305B** facing away from the stationary magnets **302** has north pole N polarity along its length **L**.

[0112] There are relatively small gaps **307A**, **307B** (e.g., approximately 1 mm or touching each other) between adjacent stationary magnets **302** along the stationary magnet path **306**. The distances of the gaps **307A**, **307B** are substantially equal between the adjacent stationary magnets **302**, however, the distances of the gaps **307A**, **307B** may be unequal in order to configure the system in a particular manner as is later discussed herein in greater detail. There is also a relatively small rotor-stator gap **307C** (e.g., 2 mm Teflon coating on bottom surface **303A** of rotor magnet **304**) between the movable magnet **304** and the top surface level of the stationary magnets **302**. Other gap sizes, magnetic geometries, and configurations may be used if desired.

[0113] Also, the three rectangular flat magnets for the stationary or stator magnets **302A**, **302B**, **302C** (collectively referred to as the stator magnets **302**) in the embodiments of FIGS. **3A-3J** may be Neodymium grade N42 permanent magnets, having a length of about 1", width of about ½

inches and thickness of about ¼ inches, made by K&J Magnetics. The rectangular flat magnet for the movable or rotor magnet **304** in this embodiment may be Neodymium grade N42 permanent magnets, having a length **L** of about 3", width of about ½ inches and thickness of ¼ inches, made by K&J Magnetics, part number B2084. Other dimensions and shapes of the magnets may be used if desired depending on the design requirements. Also, the magnets may be glued (or epoxied) to or embedded into or clamped to the housing or plates or may have holes located transversely through the thickness of the magnets to receive bolts or screws or the like to secure the magnets to the housing or plates if desired. Also, having transverse holes through the rectangular magnets may also be used to provide increased magnetic field strength of the magnets, which may enhance performance in some applications.

[0114] Referring to FIG. **3B**, since there is a relatively small gap **307C** between the movable magnet **304** and the top surface **303A**, **303B**, **303C** of the stationary magnets **302**, the south pole S polarity of the bottom side **305A** of the movable magnet **304** and the matching (repulsive) south pole S polarity of the middle stationary magnet **302B** generate magnetic field blooms **311** of similar polarity S (FIG. **3B**) at least in a horizontal (or lateral) direction from the magnets **302**, **304** due to the known Halbach effect.

[0115] Referring to FIG. **3C**, when an angular external applied force **AF** acts on the upper rectangular movable magnet **304**, there are at least two repulsive magnetic forces **310** generated due to the matching polarity of the south pole polarity magnetic field blooms **311** and the bottom side **305A** of the movable magnet **304** (south-south), one at each end of the movable magnet **304** which are in compression pushing against the applied force **AF** for each magnetic field bloom **311** for a total of at least two repulsive forces **310**. Also, there are two attractive magnetic forces **312** due to the opposite polarities of the first stationary magnet **302A** and the bottom side **305A** of the movable magnet **304** (north-south) and the opposite polarities of the third stationary magnet **302C** and the bottom side **305A** of the movable magnet **304** (north-south) which are in tension or stretched during rotation and also act against the applied force **AF**. The position of the movable magnet **304** shown in FIGS. **3A** and **3B** may be considered an equilibrium state or equilibrium state position (ESP). In the equilibrium state, the sum of the forces acting on the movable magnet **304** are zero such that the movable magnet **304** remains stationary.

[0116] Referring to FIG. **3C**, in operation, an applied force **AF** is applied to a side of the movable magnet **304** in a counter-clockwise rotational direction **309B**. The applied force **AF** causes the movable magnet **304** to move an angular stress distance **316** from the equilibrium state position. The configuration of the magnetically-coupled device **300A** opposes the applied force **AF**. The repulsive forces **310** between the movable magnet **304** and the magnetic field blooms **311** that the ends of the movable magnet **304** are rotated towards due to the rotation, increases as the movable magnet **304** moves towards the magnetic field blooms **311**. When the movable magnet **304** is in the stressed state position, at least one of the magnetic field blooms **311** is compressed (or in a compressed state) compared to when the movable magnet **304** is in the equilibrium state position. The attractive forces **312** between the first stationary magnet **302A** and the movable magnet **304**, and the third stationary magnet **302C** and the movable magnet **304** decrease due to

the magnetic fields being “stretched” (or in tension) from being moved away from each other. The magnetically-coupled device 300A in FIG. 3C may be considered to be in a stressed state or stressed state position.

[0117] When the applied force AF is removed (or decreased in strength), the device 300A will seek to (or be biased to or attempt to) return the movable magnet 304 to the equilibrium state position (ESP), i.e., the position shown in FIGS. 3A and 3B. The device 300A will seek to achieve the equilibrium state position because the sum of the angular magnetic forces on the movable magnet 304 is not equal. In particular, with the AF removed, the angular repulsive forces 310 together with the angular attractive forces 312, force the movable magnet 304 towards the equilibrium state position (ESP). Advantageously, the movable magnet 304 may rotate any number of times in either direction of the rotational direction 309. In other words, the movable magnet 304 may move 360° or more in a first rotational direction 309A (counterclockwise) and/or 360° or more in a second rotational direction 309B (clockwise).

[0118] Referring to FIG. 3D, the magnetically-coupled device 300A of FIG. 3A is shown from a side view in FIG. 3D. The magnetically-coupled device 300A may have a housing which contains the magnets described hereinabove and includes the bottom plate 321, and is connected to an input shaft 320 (which receives input rotational force or torque) and an output shaft 320A (which provides output torque). The housing and support structure for the input shaft 320 and output shaft 320A including the bearings or bushings for the input shaft 320, and bottom plate and mounting flange for the output shaft 320A, may be the same as that described with FIG. 2A. However, in this case, there may be a spacer between the top of the rotor and inner ceiling of the housing or casing (rotor top-gap) and there may be locking bolts on the input shaft to set the rotor-stator gap. Other configurations and housings may be used if desired provided it provides the desired function and performance.

[0119] Referring to FIGS. 3E and 3F, the embodiment shown in FIGS. 3B-3D may have additional stationary rectangular permanent magnets 320,322 disposed adjacent to the three stationary (or stator) permanent magnets 302A, 302B, 302C, and may be referred to herein as the “H-drive” design, as described below. The additional stationary rectangular permanent magnets 320,322 are polarized with the South (S) side of the magnet facing upward toward the movable magnet 304, which is polarized with the South (S) side of the magnet 304 facing downward toward the three stationary (or stator) permanent magnets 302A, 302B, 302C, as described hereinbefore. In that case, the magnetic field bloom 311 (from the Halbach effect discussed hereinbefore), takes on the shape of the letter “H”, as shown in FIG. 3E, when the movable magnet 304 is in the vertical position, which is the equilibrium state position (ESP) for this embodiment. The H-shape of the field bloom 311 is caused by the added side magnets 320, 322, which also increases the strength of the magnetic field acting on the movable magnet 304. The magnets 320,322 may be the same length and type as the combination of the three stationary permanent magnets 302A, 302B, 302C (collectively, the magnets 302) or be the same length and type as the movable magnet 304. Also, the added magnets 320,322 may have the same thickness as the three stationary permanent magnets 302A, 302B, 302C to help facilitate rotation of the movable magnet 304 when the movable magnet 304 is located very close to or touching

the stationary permanent magnets 302A, 302B, 302C, 320, 322. The magnetic field strength the added magnets 320,322 may be the same as the movable magnet 304 or different therefrom if desired. For example, the rectangular flat magnet for the added stator magnets 320,322 may be Neodymium grade N42 permanent magnets, having a length L of about 3", width of about ½ inches and thickness of ¼ inches, made by K&J Magnetics, part number B2084, and may be attached to a housing or plate in a similar way as the other stationary magnets 302, as discussed herein. Also, having transverse holes through the rectangular added side magnets 320,322 may also be used to provide increased magnetic field strength of the magnets, which may enhance performance in some applications.

[0120] Referring to FIG. 3F, when the rotational applied force AF is applied to the side of the movable magnet 304 in a rotation direction 309B (clockwise), the applied force AF causes the movable magnet 304 to move an angular distance 316 from the equilibrium state position and the device 303A may be considered to be in a stressed state or stressed state position (SSP). As the movable magnet 304 moves clockwise, the repulsive forces 310 between the movable magnet 304 and the magnetic field blooms 311 that the ends of the movable magnet 304 increase as the movable magnet 304 moves towards and push against the magnetic field blooms 311. When the movable magnet 304 is in the stressed state position, at least one of the magnetic field blooms 311 is compressed (or in a compressed state) compared to when the movable magnet 304 is in the equilibrium state position (FIG. 3E), and the H-shaped blooms becomes distorted or altered. The attractive forces 312 between the first stationary magnet 302A and the movable magnet 304, and the third stationary magnet 302C and the movable magnet 304 decrease due to the magnetic fields being “stretched” (or in tension) from being moved away from each other, similar to that described in the embodiments of FIGS. 3B and 3C; however, the strength of the field blooms 311 are stronger in this embodiment due to the added side magnets 320,322. Also, the embodiments of FIGS. 3E and 3F may have the same side view as FIG. 3A and same housing as FIG. 3D.

[0121] Referring to FIGS. 3G, 3H, 3I, 3J, an alternative to the embodiment of the magnetically-assisted torque assist device of FIGS. 3E and 3F is shown, and may be referred to herein as the “N-drive” design, as described below. In that case, the additional stationary rectangular permanent magnets 320,322 are polarized with the south (S) side of the magnet facing upward toward the movable magnet 304, which is polarized with the North (N) side of the magnet 304 facing downward toward the three stationary (or stator) permanent magnets 302A, 302B, 302C, as shown in FIGS. 3G and 3I.

[0122] In particular, referring to FIG. 3I, when the movable magnet 304 is in a right-tilted position, such that the top end of the movable magnet 304 is over the added magnet 322, this is one of the equilibrium state positions (ESP) for this embodiment. In particular, because the bottom face 305A of the movable magnet 304 is polarized as N, it will be repelled by the top and bottom stator permanent magnets 302A, 302C, which are also polarized as N, also the added magnets 320,322 are polarized as S facing toward the movable magnet 304, which causes a strong attraction to the bottom face 305A of the movable magnet 304 is polarized as N. This combination of repulsive and attraction forces is

greater than the attraction between the movable magnet **304** and the center stator magnet **202B**. Thus, the equilibrium state position of the movable magnet **304** will be either of the right-tilted position (FIG. 3I) or the left-tilted position (not shown).

[0123] In the right-tilted position (FIG. 3I), the magnetic field bloom **311** (from the Halbach effect discussed hereinbefore), takes on the shape of an inverted letter “N”, when including the movable magnet **304** as part of the bloom field, as shown in FIG. 3I. Similarly, when the movable magnet **304** is in a left-tilted position (not shown), such that the top end of the movable magnet **304** is over the added magnet **320**, this is another equilibrium state position (ESP) for this embodiment, and the magnetic field bloom **311** (from the Halbach effect discussed hereinbefore), takes on the shape of a normal letter “N”, when including the movable magnet **304** as part of the bloom field **311**, as shown in FIG. 3I.

[0124] The inverted or normal N-shaped field bloom **311** when in the equilibrium state position is caused by the added side magnets **320**, **322**, which also increases the strength of the magnetic field acting on the movable magnet **304**. The magnets **320**, **322** may be the same length as the combination of the three stationary permanent magnets **302A**, **302B**, **302C** or be the same length as the movable magnet **304**. Also, the magnets **320**, **322** may have the same thickness as the three stationary permanent magnets **302A**, **302B**, **302C** to help facilitate rotation when the movable magnet is located very close to or touching the stationary permanent magnets **302A**, **302B**, **302C**, **320**, **322**. The magnetic field strength may be the same as the movable magnet **304** or different therefrom if desired.

[0125] Referring to FIG. 3H, when the rotational applied force AF is applied to the side of the movable magnet **304** in a counter-clockwise rotation direction, the applied force AF causes the movable magnet **304** to move an angular distance **316** from the equilibrium state position (FIG. 3I), the device **303A** may be considered to be in a stressed state or stressed state position (SSP). As the movable magnet **304** moves counter-clockwise, the repulsive forces **310** between the ends of the movable magnet **304** and the magnetic field blooms **311** that the ends of the movable magnet **304** increase as the movable magnet **304** moves towards and push against the magnetic field blooms **311**. When the movable magnet **304** is in the stressed state position, at least one of the magnetic field blooms **311** is compressed (or in a compressed state) compared to when the movable magnet **304** is in the equilibrium state position (FIG. 3E), and the blooms **311** become distorted or altered. The attractive forces **312** between one (proximal) end of the movable magnet **304** and the added (left) side magnet **320**, and between the opposite (distal) end of the movable magnet **304** and the other added (right) side magnet **322** decrease due to the magnetic fields being “stretched” (or in tension) from being moved away from each other. Also, the embodiments of FIGS. 3G and 3J show the side view and housing for this embodiment, which are similar to that in may have the same side view as FIG. 3A and same housing as FIG. 3D.

[0126] As with other embodiments described herein, the gap between the rotor and stator permanent magnets influences the magnetic field strength, with a larger gap corresponding to a weaker magnetic attraction or repulsion. In the case of the Halbach designs described herein (FIGS. 3A-3J), the field bloom **311** will decrease (or as large in size or density) as the rotor-stator gap **307C** is increased, as one

aspect of the Halbach effect is to force two magnetic faces of like-polarity together (e.g., N-N or S-S) to effectively squeeze the flux field out the sides into adjacent areas, thereby creating the magnetic field or flux “bloom” discussed herein.

[0127] Also, the added stator magnets **320**, **322**, may touch the other stator magnets **302A**, **302B**, **302C**, or there may be gaps **324**, **326** between them, e.g., about 1 mm and the left side gap **324** and right side gap **326** distances may be equal or unequal depending on the desired system performance. Other gap distances may be used if desired depending on the desired system performance. Also, instead of having three separate stationary (or stator) magnets **302A**, **302B**, **302C**, a single magnet may be used having three regions which have the desired magnetic polarization along its length that performs the same function as the three separate magnets. Also, the stator magnets **302A**, **302B**, **302C**, may be comprise a plurality of smaller magnets that are stacked together to perform the same function as the stator magnets **302A**, **302B**, **302C** described herein.

[0128] Referring to FIG. 4A, a magnetically-coupled device **400A** is shown from a top view. The magnetically-coupled device **400A** includes a plurality of stationary magnets **402** (**402A-4021**), a first movable magnet **404A** and a second (or center) movable magnet **404B**. The first movable (rotor) magnet **404A** (or wiper or swing magnet) is connected to a rotatable shaft **450** through an arm **451**. The stationary magnets **402** may be rectangular straight bar magnets polarized on their faces along their length (largest surface area) that are arranged in a “daisy” configuration except for the stationary magnet **4021** arranged beneath the second movable magnet **404B** in an axial direction of the shaft **450**. As such, the distance between stationary magnets **402** in a circumferential direction increases as the radial distance from the shaft **450** axis of rotation increases.

[0129] The first movable magnet **404A** and the second movable magnet **404B** are configured to rotate in the rotation direction **409** (clockwise or counterclockwise) with the shaft **450** about the shaft axis of rotation (or magnet axis rotation discussed above). The first movable magnet **404A** may be adjustable along the arm **451** in a radial direction from the shaft **450** through known mechanical adjust mechanisms, e.g., nut adjustment, sliding shifter, adding or removing washers, or spacers, or the like. The adjustment of the first movable magnet **404A** allows another degree of freedom in the magnetically-coupled device design. For instance, the amount of force required to magnetically break or decouple the first movable magnet **404A** to another equilibrium state position (ESP) can be adjusted through adjustment of the first movable magnet **404A** position along the arm **451**.

[0130] Similar to the operation of the magnetically-coupled device **200C** of FIG. 2G and the magnetically-coupled device **200E** of FIG. 2L, the second movable (or rotatable) magnet **404B** and, thus, the arm **451** and first movable magnet **404A**, can be forced to a displaced position (or new position) in the axial direction of the shaft when the second movable magnet **404B** is rotated enough such that the opposing magnetic forces from the stationary magnet **4021** beneath the second movable magnet **404B** is strong enough to force the movable elements away (or “pop-up” from the stator magnet). As in the other embodiments discussed herein, the movable magnets **404A**, **404B** and the arm **451** can return to the position shown in FIG. 4A when

rotated enough to return the elements to their original position in the axial direction.

[0131] Referring to FIG. 4B, a magnetically-coupled device 400B is shown from a top view. The magnetically-coupled device 400B is substantially the same as the magnetically-coupled device 400A of FIG. 4A, except that the first movable magnet 404A is curved in the direction of rotation 409. The shape and size of the first movable magnet 404A allows for another degree of freedom in the magnetically-coupled device design.

[0132] Referring to FIG. 4C, a top view of a magnetically-coupled device 400C is shown. The magnetically-coupled device 400C includes a stator component 401A and a rotor component 401B. The stator component 401A includes a stator ring 421 containing a plurality of stationary magnets 402. The stationary magnets 402 are arranged in a daisy pattern as in the embodiments shown in FIGS. 4A and 4B, with an optional central cylindrical stationary magnet 4021. The rotor component 401B includes a rotor ring 422 containing a plurality of movable magnets 404 arranged in a daisy pattern with an optional central cylindrical movable magnet 4041.

[0133] The operation of the magnetically-coupled device 400C is similar to other magnetically-coupled device embodiments described herein. When the rotor component 401B is arranged to rotate over the stator component 401A, the plurality of magnetic forces will seek to keep the rotor component 401B in one of the equilibrium state positions (ESP). When the rotor component 401B is rotated enough, the opposing magnetic forces, including the opposing magnetic forces from the central stationary magnet 4021 and the central movable magnet 4041 will force the rotor component 401B to a displaced position (or new position). After further rotation of the rotor component 401B, the rotor component 401B can return to its original axial position relative to the stator component 401A.

[0134] FIG. 4D is a side cut-away view of a portion of the magnetically-coupled device of FIG. 4C without the optional cylindrical magnets, in accordance with embodiments of the present disclosure. The magnetically-coupled device of FIG. 4D may have a housing which contains the magnets described hereinabove, and is connected to an input shaft 420 (which receives input rotational force or torque) and an output shaft 420A (which provides output torque). The housing and support structure for the input shaft 420 and output shaft 420A including the bearings or bushings for the input shaft 420, and bottom plate and mounting flange for the output shaft 420A, may be the same as that described with FIG. 3D. However, in this case, there may be a spacer between the top of the rotor and inner ceiling of the housing or casing (rotor top-gap) and there may be locking bolts or the like on the input shaft to set or adjust the rotor-stator gap. Other configurations and housings may be used if desired provided it provides the desired function and performance.

[0135] More specifically, the casing or housing may have an outer diameter D of about 5 inches and an inner diameter of about 4 inches, and, thus, a housing wall thickness of about ½ inch. The housing height H may be about 1.5 inches tall and the gap G between the rotor and stator magnets may be about 5 mm to about ⅛ inches. Also, the rotor top-gap between the top of the rotor plate to which the rotor magnets are attached and the inner ceiling of the housing, may be about ¼ inches (but other top-gaps may be used if desired). Also, other rotor-stator gaps G may be used if desired

depending on the desired performance requirements, as discussed herein. The other components of the magnetically-coupled device such as the input shaft, bearing, output shaft, and connecting flanges may be the same as that described hereinbefore with FIG. 2A or FIG. 3D. The housing and the rotor plate may be made of a ferrous material such as steel or other magnetic conducting material, which enhances the flux strength, as described hereinbefore with FIG. 2A. The rotor plate may have a diameter of about 3.5 inches. Other dimensions may be used if desired. This structure may be used with any geometry magnets, e.g., rectangular, square, circular, cylindrical, or any other shape, such as those geometries described herein or any other geometries/shapes.

[0136] Also, the rectangular flat magnets in FIGS. 4A-4D may be Neodymium grade N42 permanent magnets, having a length L of about 1", width of about ½ inches and thickness of about ¼ inches, made by K&J Magnetics. Also, the magnets may be glued (or epoxied) to or embedded into or clamped to the housing or plates or may have holes located transversely through the thickness of the magnets to receive bolts or screws or the like to secure the magnets to the housing or plates if desired. Other dimensions and shapes for the magnets may be used if desired depending on the design requirements. Also, having transverse holes through the rectangular magnets may also be used to provide increased magnetic field strength of the magnets, which may enhance performance in some applications.

[0137] Referring to FIG. 5A, a diagram 401 shows a system of a plurality of magnetically-coupled devices 400A, 400B, 400C, 400D (collectively identified as 400) connected in series, adjacent devices connected by shafts 402A, 402B, 402C, in accordance with embodiments of the present disclosure. The plurality of devices 400 includes a first magnetically-coupled device 400A having an input shaft 404 and a first spring constant K_1 , a second magnetically-coupled device 400B having a second spring constant K_2 , a third magnetically-coupled device 400C having a third spring constant K_3 and a fourth magnetically-coupled device 400D having a fourth spring constant K_4 . In this embodiment, the devices 400 are arranged in ascending order of spring constant magnitude, e.g., $K_1 < K_2 < K_3 < K_4$. In some embodiments, the last device 400D may be fixed and not have an output shaft.

[0138] Referring to FIG. 5B, in some embodiments, instead of rotational center shaft configuration they may operate in a planar arrangement having various different spring constants or stiffnesses as described herein (with FIGS. 1A-1E and 1J), where the applied force is, e.g., from the left side (or right). Any other arrangement of a plurality of the magnetically-coupled devices or torque assist devices may be used if desired.

[0139] While the diagrams 401 and 401A show the system having four magnetically-coupled devices, it should be readily understood that in embodiments according to the present disclosure there may be less or more than four magnetically-coupled devices 400. Further, it should be readily understood that the magnetically-coupled devices are not always arranged in ascending or descending order of spring constant K.

[0140] Referring to FIG. 6, a plot (or graph) 500 (and corresponding data table) is shown of experimental data of a magnetically-coupled device similar to the device 200A shown in FIGS. 2A-2C, and two cylindrical permanent magnets described herein. The plot 500 shows a curve 501

representing the monitored applied force AF applied at 2.5 inches from the movable magnet axis 208 on an exemplary magnetically-coupled device. The curve 501 is plotted in Lbs of applied force AF against angle (in degrees) of deflection (or rotation) of the movable magnet. The curve 501 increases substantially linearly through 90° of deflection (or rotation) of the movable magnet 204. After 90° of deflection, the applied force necessary for rotating the movable magnet 204 decreases substantially linearly until it reaches 180°. There are two dashed lines shown for the increasing curve (0-90 degrees), the upper dashed line shows a straight line through the points from 30-90 deg., which appears to be very close to a linear response. The lower dashed line shows a straight line through all the points from 0-90 deg., which is also close to a linear response. There is a single dashed line shown for the decreasing curve (90-180 deg.), this dashed line is a straight line through the points from 90-180 deg., which appears to be very close to a linear response. Various linear approximations or curves fits for the data may be used if desired, however, the dashed lines show a substantially linear response for various regions of operation.

[0141] The slope (or slopes) of the curve 501 (or portions thereof) may be considered an approximation for the spring constant K (or stiffness) of the magnetically-coupled device over a particular operating range (or range of angles or forces). As discussed above, the spring constant K and, thus, the slope of the curve 501 (or portions thereof), may be selectively determined by configuring the magnetically-coupled device parameters such as magnet(s) strength, including any housing or mounting plate materials and the rotor-stator magnet gap distances.

[0142] It should be understood that any desired elastic force/distance profile may be created with the present disclosure, including partially linear, partially non-linear or any desired force/distance profile based on the magnets, gap, and materials used.

[0143] FIGS. 7A-7D (describe in more detail below) show embodiments of magnetically-coupled or torque assist device (s) of the present disclosure having no mechanical connection between the rotor and stator, i.e., no bearings or bushings or housing that mechanically connect (or provide mechanical contact between) the rotor and stator. In that case, there may be a removable spacer or spacers disposed between the rotor and stator, shown as dashed rectangular box or boxes. The removable spacers may be used to keep the rotor and stator physically separated from each other before installation (as they will be attracted to each other due to the rotor-stator opposite magnetic field (N-S; S-N) attraction). Once the input and output shafts are connected, e.g., via appropriate couplings or the like, to their respective other components in the system, e.g., other shafts that are fixed in position, the spacer(s) may be removed and the magnetically-coupled or torque assist device will operate without any mechanically attached parts, thereby providing a device with no mechanical wear or friction, which reduces device maintenance. There may also be an optional housing, shown as a large outer dashed box, which may be used to contain or hold the parts during installation of the device into a larger system (e.g., attachment of the input and output shaft to other system shafts); however, the housing would not physically touch any moving parts of the device. The housing may also be used as a protective or safety cover or shield to protect personnel from rotating machinery or to protect the

magnets in the magnetically-coupled device from attracting external metallic or magnetic parts or for other safety or performance reasons.

[0144] Referring to FIG. 7A, a magnetically-coupled device shaft configuration 701A is shown in accordance with embodiments of the present disclosure. The shaft configuration 701A comprises a magnetically-coupled device 700A having a first component (or rotor) 784A in the form of a drum connected to an input shaft 780A and a second component 786A (or stator) in the form of a drum connected to an output shaft 790A. The first component 784A contains a first set of magnets 785A contained on an external surface of the drum facing the second component 786A, and the second component 786A contains a second set of magnets 787A contained on an external surface of the drum facing the first component 784A. The shaft configuration 701A is such that the first component 784A and the second component 786A are arranged side-by-side in an axial direction of the input shaft 780A and/or output shaft 790A.

[0145] In operation, rotation of the input shaft 780A in the rotation direction 782 causes rotation of the first component 784A of the magnetically-coupled device 700A. The magnetic forces caused by the rotation will cause rotation of the second component 786A in accordance with magnetic forces generated by the magnetically-coupled device embodiments discussed herein thereby driving the output shaft 790A in the rotation direction 792.

[0146] Referring to FIG. 7B, a magnetically-coupled device shaft configuration 701B is shown in accordance with embodiments of the present disclosure. The magnetically-coupled device shaft configuration 701B is substantially the same as the magnetically-coupled device shaft configuration 701A of FIG. 7A except that the first component 784B is arranged within a recess of the second component drum 786B. The first set of magnets 785B are arranged on a circumferential outer surface of the first component 784B and the second set of magnets 787B are arranged on a circumferential inner surface of the second component 786B. Advantageously, the second component drum 786B having a recess to accommodate the first component 784B provides protection of the device 700B from particular, contaminants, etc.

[0147] Referring to FIG. 7C, a magnetically-coupled device shaft configuration 701C is shown in accordance with embodiments of the present disclosure. The magnetically-coupled device shaft configuration 701C is substantially the same as the magnetically-coupled device shaft configuration 701A of FIG. 7A and/or the magnetically-coupled device shaft configuration 701B of FIG. 7B except that the first component 784C is arranged in the form of a plate. The first set of magnets 785C are arranged on a side of the first component plate 784C facing the second component 786C and the second set of magnets 787B are arranged on an internal surface of the second component 786C facing the first component 784C.

[0148] Referring to FIG. 7D, a magnetically-coupled device shaft configuration 701D is shown in accordance with embodiments of the present disclosure. The magnetically-coupled device shaft configuration 701D is substantially the same as the magnetically-coupled device shaft configuration 701C of FIG. 7C except that the first component 784C is arranged in the form of a plate. The first set of magnets 785C are arranged on a side of the first component plate 784C facing the second component 786C and the

second set of magnets **787B** are arranged on an internal surface of the second component **786C** facing the first component **784C**.

[0149] In some embodiments, the magnetically-coupled device of the present disclosure, may be used for increasing the torque for any rotating or angularly displacing body by means of an elastic magnetic circuit using an arrangement (described herein) of high-energy permanent magnets, resulting in a magnetically-coupled “torque assist” device (or module) that may have significant utility in reducing the energy required to drive rotating machinery, such as electric car wheels, pumps, marine propellers, and the like. The magnetically-coupled device may also be used to significantly increase the energy output in applications such as wind turbines where the magnetic torque assist module may be installed between the wind vanes and an electricity-producing alternator/generator, would result in more energy output from the wind turbine at much lower wind speeds.

[0150] In addition to use in rotating machinery, the elastic nature of the magnetic circuit integral to the present disclosure also lends itself well for applications where only angular displacement is required (e.g., less than a full rotation). Applications could include, but not limited to, rehabilitation and sports training equipment, e.g., elastic resistance bands and the like, or for such applications as robotic joint torque assistance.

[0151] As described herein, the technology represented by the magnetically-coupled device or “torque assist” module described herein involves the conversion of elastic potential energy to kinetic energy. Elastic potential energy can be described as energy stored as a result of applying a force to deform an elastic object, in this case, a magnetic field. The energy is stored until the force is removed resulting in the release of kinetic energy as the elastic magnetic field springs back to its original shape, doing work (i.e., force applied \times distance moved in newtons/meter or joules) in the process. The deformation would involve compressing and stretching the elastic magnetic field created by the arrangement(s) of the permanent magnets described herein.

[0152] In some embodiments, e.g., at least FIGS. **2K** and **2L**, deformation of the elastic magnetic field may include stretching and compressing, which for circular motion applications may also be referred to as twisting the magnetic fields about a rotational axis during the conversion from potential to kinetic energy or kinetic to potential energy.

[0153] In a simple analogy, a rubber ball, representing the “torque assist” device aggregate magnetic fields, will be compressed when struck by an outside force like a bat, causing the ball to fly off the bat in its quest to regain its round shape. The magnetic field in the torque assist will behave in a similar manner when the field is compressed and stretched by the rotation of wind turbine blades, for example, attached to the torque assist module input shaft, when pushed by an outside natural input force such as wind. When the torque assist is mounted on a shaft which connects wind turbine blades and an alternator/generator, the elasticity of the torque assist magnetic field imparts far more acceleration to the alternator/generator, than simply rotating an inelastic alternator circuit and shaft attached directly to a wind turbine, resulting in increased energy output.

[0154] As described herein, in some embodiments, the disclosure may have of three diametrically magnetized (magnetized through the diameter) high energy, rare earth NdFe cylindrical magnets aligned linearly perpendicular to

a plane as described herein in FIGS. **2E** and **2F**. The three magnets may consist of a rotor magnet positioned linearly between two stator magnets. In particular, a bi-directional rotating magnet attached to a central axis shaft (a rotor), is placed between two fixed magnets (or stators, or collectively a stator). The three magnets are sandwiched between two parallel metal or plastic discs, which may be about 5" in diameter by about 1/4" in thickness. The cylindrical magnets may be about 1" long by about 1" diameter having a about 1/4" center hole. Depending on application requirements component dimensions are scalable up or down.

[0155] The rotor is mated to a center shaft, which serves as the coupling to whatever body is used to drive the torque assist device, e.g., a wind turbine, or any other prime mover that converts a natural input source of energy into mechanical and ultimately electrical energy. At rest, the rotor magnetically centers itself between the two flanking stator magnets due to opposite magnetic polarities attract. The bottom circular plate may be mounted (e.g., by an output shaft, or other appropriate coupling mechanism) to an alternator or any other device being driven.

[0156] Using the magnetic arrangement(s) described herein, in some embodiments, the more angular force applied by rotating the center rotor magnet, the stiffer the magnetic elasticity becomes until a magnetic “break point” or “decoupling point” is reached, e.g., at about 180 degrees from the start point (or resting or Equilibrium State Position (ESP) described herein), whereupon the rotor automatically snaps around to its original state (ESP). FIGS. **2B**, **2C**, and **2D** (for two total magnets), and FIGS. **2E** and **2F** (for three magnets) show in a simplified fashion, the progression of centripetal compression and stretching of the magnetic flux field from rotation initiation by the rotor **204** (FIG. **2C** and FIG. **2F**), to just before the magnetic de-coupling break point at a little before 180 degrees (FIG. **2D**), the 180 degree point shown as a vertical dashed line. When the rotor reaches the de-coupling point, the rotor automatically returns to its original state (ESP) FIG. **2B** (for two magnets) and FIG. **2E** (for three magnets). This magnetic breakaway or decoupling phenomenon becomes useful in certain applications such as wind turbines or other rotating applications, by acting as a “shear pin” (or a “torque limiter”) preventing the device or mechanism attached to the output shaft, e.g., alternator or generator or motor, from overloading and possibly catching fire, or by preventing mechanical damage to a rotating part, e.g., a shaft or gear or propeller or blade or other part. In particular, at a pre-set “decoupling” (or “torque limit”) load, the torque assist device will break the magnetic coupling and simply continue to free rotate until the load is reduced sufficiently to return to the pre-set load limit at which point the magnetic coupling will re-engage.

[0157] The strength of the magnetic field drops off geometrically from the face of the magnet so the stiffness of the magnetic circuit (or magnetic field strength) is dependent on the airgap between the rotor and the stator magnets (i.e., the rotor-stator gap). Less airgap enables more powerful units (i.e., more powerful magnetic fields, or stiffer device). Also, more powerful units can be constructed by stacking additional magnets on the stator and rotor. Units with adjustable stiffness, or elasticity, can be constructed by allowing the opposing stator magnets to be adjustable relative to the rotor magnet assembly. Stiffer torque assist modules would be particularly useful for applications where the torque assist is positioned between a power source/driver, as in an electric

motor used to drive an electric car wheel or boat propeller. With the installation of a torque assist module between the motor and the wheel, less energy will be required to spin the wheel while at the same time increasing the torque available. The result is increased fuel or electrical charge efficiency and increased power and torque available.

[0158] As described herein, e.g., with at least FIGS. 2K and 2L, in some embodiments, an additional basal (or base or bottom) fixed (or stationary) magnet 202D (FIG. 2K), 202C (FIG. 2L), may be added, e.g., diametrically magnetized cylindrical magnet of the same diameter, immediately below and in-line with (or common central axis to) the rotor magnet 204. This arrangement gives the torque assist module another axis of elasticity.

[0159] As with the other embodiments discussed herein with FIGS. 2A-2F and 2M, in the basal magnet embodiment the magnetic fields are simultaneously stretched and compressed about the vertical axis of the torque assist device, which may also be referred to herein as twisted or rotated (at least partially) about the vertical axis before the magnetic decoupling occurs. The total efficiency of the torque assist module may be further enhanced by adding the basal magnet to the embodiments described above.

[0160] This basal magnet embodiment may also be used in certain applications utilizing only the rotor magnet and the basal (bottom) magnet in a simple two-magnet arrangement. A variation of such an embodiment is shown in FIGS. 2G-2J, where the rotor magnet automatically moves or “pops” away from the stator magnet along the rotation axis when magnetic decoupling occurs. As in other embodiments described herein, the magnetic elasticity characteristics of the basal magnet lends itself well for both full rotational and partial angular displacement.

[0161] Referring to FIGS. 8A and 8B, a magnetically-coupled device 800A is shown from a top view. The magnetically-coupled device 800A includes a plurality of stationary magnets 802 (802A-802H) and a plurality of movable magnets 804 (804A-804H). The polarities of the movable magnets 804 shown in the drawings are the sides of the magnets 804 facing the stator ring 821A and/or stationary magnets 802. The stationary magnets 802 are arranged on (or within) a stator ring 821A of a stator component and movable magnets 804 are arranged on (or within) a rotor ring 822A of a rotor component. This arrangement of magnets 802, 804 may be referred to as a square magnet configuration or cubic magnet arrangement. The rotor ring 822A is connected to a rotatable shaft 850. The rotor ring 822A and/or the stator ring 821A may be configured to allow the rotatable shaft 850A to extend therethrough. The rotatable shaft 850A and/or the rotor ring 822A are configured to rotate about an axis of rotation 808A. The magnetically-coupled device 800A is configured to provide torque-assist when the rotor ring 822A is rotated similar to other magnetically-coupled device embodiments disclosed herein. In this embodiment, the stationary magnets 802 are the same size and shape as the movable magnets 804, but in other embodiments, the magnets 802, 804 may be different sizes. The stationary magnets 802 and movable magnets 804 are preferably square or rectangular permanent magnets. The magnets 804 are arranged such that perpendicular rotor axes 823A, 823B each bisecting the rotor ring 822A and intersecting the axis of rotation 808A are arranged between pairs

of magnets 804. The stationary magnets 802 may be arranged similarly with respect to axes bisecting the stator ring 821A.

[0162] The lateral gap distances 807 (807A-807D) between pairs of movable magnets 804 may be selected or adjusted in order to determine the characteristics of the device 800A and/or the torque required to rotate the rotor ring 822A relative to the stator ring 821A. The lateral distance gaps between pairs of the stationary magnets 802 may be similarly selected or adjusted for determining characteristics of the device 800A and/or the torque required to rotate the rotor ring 822A relative to the stator ring 821A. Also, the air gap between the rotor plate and the stator plate may be adjusted through magnet air gap adjusting mechanisms (as discussed with other embodiments herein above) to determine the characteristics of the device 800A and/or the torque required to rotate the rotor ring 822A relative to the stator ring 821A.

[0163] The cubic magnet arrangement of the magnetically-coupled device 800A allows the inertial or angular spin force vector upon startup to be projected tangentially from the outer circumferential edge of the rotor ring (where the magnets are located). This feature allows the magnetically-coupled device 800A to spin-up faster with less energy input as opposed to conventional industry “daisy wheel” magnet arrangements, particularly when integrated into a flywheel system. Once the magnetic coupling plates (e.g., stator component and rotor component) are fully engaged or torqued, i.e., rotated the maximum amount from their equilibrium point (or equilibrium state position (ESP)), or when more potential energy being stored, the force vector begins to resemble that of the “daisy wheel” configuration. Thus, the cubic magnet arrangement of the magnetically-coupled device 800A, provides a tangential startup the angular spin force vector located a distance from the axis of rotation 808A, and then as the magnetic coupling plates more fully engage (i.e., torqued), the spin force vector relative to the axis of rotation begins to tighten up to be more centripetal (pointing radially inward) for maintaining speed.

[0164] Referring to FIG. 8C, a top view of an exemplary movable magnet 804 of the device 800A of FIGS. 8A and 8B is shown. The movable magnet 804 comprises a long axis 828 (or first axis) bisecting the magnet 804 through the short edges 829, and comprises a short axis 830 (or second axis) bisecting the magnet 804 through the long edges 831. The magnet 804 of FIG. 8C is a rectangular magnet. If the magnet 804 were a square magnet, the long axis 828 and short axis 830 would bisect the magnet along edges 829, 831 of equal length. In the magnetically-coupled device 800A of FIG. 8A, the movable magnets 804 are arranged so that the long axis 828 and the short axis 830 of each movable magnet 804 would not intersect the axis of rotation 808A, and/or at least one of the long axis 828 or the short axis 830 of each movable magnet 804 is parallel to the corresponding axis 828, 830 of another movable magnet 804 with a different polarity facing the stator ring 821A and/or stationary magnets 802, e.g. the long axis 828 of the movable magnet 804A showing north polarity is parallel to the long axis 828 of the movable magnet 804B showing south polarity, the long axis 828 of the movable magnet 804C showing north polarity is parallel to the long axis 828 of the movable magnet 804D showing south polarity, etc. This square or cubic arrangement is unlike the arrangement of other embodiments such as the “daisy” configuration of FIG. 4A where the long/short

axes of those movable magnets would intersect the axis of rotation (be oriented radially) and/or not be parallel with long/short axes of movable magnets of different polarity. In some embodiments, at least one pair of movable magnets **804** have at least one axis **828**, **830** parallel with the axis **828**, **830** of another movable magnet **804** and/or are parallel with one of the perpendicular rotor axes **823A**, **823B**. In some embodiments, all of the movable magnets have at least one other movable magnet **804** with a corresponding parallel axis **828**, **830**. In the embodiment of FIGS. **8A** and **8B**, four magnets **804A**, **804B**, **804E**, **804F** have a long axis **828** in parallel with each and in parallel with one rotor axis **823A**, and four magnets **804C**, **804D**, **804G**, **804H** have a long axis **828** in parallel with each other and in parallel with the other rotor axis **823B**.

[0165] In some embodiments, the magnets **802,804** may be rectangular permanent magnets similar to those described herein before with other embodiments, having a length **831** of **1"**, a width **829** of $\frac{1}{2}"$ and a thickness of $\frac{1}{4}"$ (i.e., $1" \times 0.5" \times 0.25"$), and the lateral gap distance **807** between magnets is $\frac{1}{2}"$. Also, the air gap distance may be about $\frac{1}{4}"$. Other dimensions, shapes and gaps may be used if desired. For example, the permanent magnets **802,804** may be square-faced permanent magnets were the length and width are the same value.

[0166] Referring to FIG. **8D**, a magnetically-coupled device **800B** is shown from a top view. The magnetically-coupled device **800B** is similar to the magnetically-coupled device of FIG. **8A**, except that the magnetically-coupled device **800B** includes twelve stationary magnets **802** (**802I-802T**) and twelve movable magnets **804** (**804I-804T**). The rotor ring **822B** is configured to attach to a rotatable shaft **850B** and may be configured to allow the rotatable shaft **850B** to extend therethrough.

[0167] It should be understood that in the context of the present disclosure, a permanent magnet is a magnet that generates a persistent magnetic field without requiring electrical current from an external power source. For example, rare-earth doped NdFe permanent magnets may be used for any of the embodiments described herein. Other permanent magnets may be used provided they provide the function and performance described herein.

[0168] The phrase "stationary magnet" or "stationary magnets" or "stator magnets" as they are used herein should not be construed to mean that the stationary magnet(s) are absolutely stationary and not moving. While in some embodiments the stationary magnet(s) is/are absolutely stationary. In other embodiments, the stationary magnet(s) may be moving generally as desired or as the application requires. Further, it should be readily understood that for embodiments disclosed herein, the "stationary" (or stator) magnet(s) may be configured to move and/or rotate with respect to the "movable" (or rotor) magnet(s) and the movable magnet(s) are configured to be stationary. Thus, in some embodiments, the stator may become the rotor and the rotor may become the stator. Accordingly, for any of the embodiments described herein having an input shaft and output shaft, the labels of the input shaft and the output shaft may be reversed if desired and the performance will be the same. Which magnets, e.g., type, material, size, power, and shape, are configured as the stationary and movable magnets may be chosen as desired and/or based on the application requirements to provide the desired performance.

[0169] It should be readily understood that the magnetic polarity of the magnets of the magnetically-coupled devices described herein can be reversed and achieve the same intended function and structure. Specifically, a magnet side (or surface) having north pole N polarity may instead have south pole S polarity and a magnet side (or surface) having south pole S polarity may instead have north pole N polarity, and the magnetically-coupled device will function substantially the same as disclosed herein.

[0170] While the present disclosure has shown and described the permanent magnets as being circular flat magnets, cylindrical magnets and bar magnets, it should be readily understood that any permanent magnet shape is within the scope of the present disclosure. Even in a single magnetically-coupled device, the stationary magnet(s) and movable magnet(s) may differ in shape and type. For example, the cylindrical magnets may be cylinders and/or cylinders with a central bore or hole defined therein in a longitudinal direction of the cylindrical magnet(s). Instead of the central bore (or in addition thereto), the magnets may be provided with blind bores. Magnets may be configured with the necessary central bore and/or blind bores for enhancing the magnetic fields thereof or generating the desired magnetic fields thereof. Other magnet shapes, such as rectangular magnets or flat magnets, may have transverse (through the thickness) bores or holes or blind bores for enhancement or desired magnetic field shapes/strengths for rotor and/or stator magnets. Further, while the stationary magnets have been described as being separate magnets, it is within the scope of the present disclosure for the stationary magnets to form a single, unitary piece or structure. Also, any given permanent magnet described herein may comprise a plurality of smaller permanent magnets that are stacked together to perform the same function and polarity as the given permanent magnet, if desired.

[0171] Advantageously, magnetically-coupled devices according to the present disclosure may be used as a "torque assist" device, which converts elastic potential energy into kinetic energy as described herein. The devices according to the present disclosure may be used to replace or supplement a spring or other elastic body in a given application. In some embodiments, instead of separate magnets providing the polarities described, there may be a single permanent magnet that has regions with the required polarities described herein. Also, in some embodiments, the polarities described herein may be provided by a plurality of small magnets attached or coupled together to provide the required polarities described herein.

[0172] Although the invention has been described and illustrated with respect to exemplary embodiments thereof, the foregoing and various other additions and omissions may be made therein and thereto without departing from the spirit and scope of the present disclosure. It should be understood that, unless otherwise explicitly or implicitly indicated herein, any of the features, characteristics, alternatives or modifications regarding a particular embodiment herein may also be applied, used, or incorporated with any other embodiment described herein.

What is claimed is:

1. A magnetically-coupled torque-assist device, comprising:
 - a rotor including a plurality of movable magnets arranged within or on the rotor;

a stator including a plurality of stationary magnets arranged within or on the stator;
 wherein the plurality of movable magnets and the plurality of stationary magnets are permanent magnets;
 wherein the plurality of movable magnets are square magnets or rectangular magnets;
 wherein at least two movable magnets of the plurality of movable magnets each define a first axis bisecting the respective movable magnet through a first pair of edges of the movable magnet and a second axis bisecting the respective movable magnet through a second pair of edges of the movable magnet; and
 wherein the first axis of a first magnet of the at least two movable magnets is parallel to the first axis of a second magnet of the at least two movable magnets or the second axis of the first magnet is parallel to the second axis of the second magnet.

2. The magnetically-coupled torque-assist device according to claim 1, wherein the plurality of movable magnets comprises eight movable magnets, and wherein the eight movable magnets comprises the at least two movable magnets.

3. The magnetically-coupled torque-assist device according to claim 2, wherein the eight movable magnets each define a first axis bisecting the respective movable magnet through a first pair of edges of the movable magnet and a second axis bisecting the respective movable magnet through a second pair of edges of the movable magnet; and
 wherein the first axis of each magnet of the eight movable magnets is parallel to the first axis of another magnet of the eight movable magnets or the second axis of each magnet of the eight movable magnets is parallel to the second axis of another magnet of the eight movable magnets.

4. The magnetically-coupled torque-assist device according to claim 1, wherein the plurality of movable magnets comprises twelve movable magnets, and wherein the twelve movable magnets comprises the at least two movable magnets.

5. A magnetically-coupled torque-assist device, comprising:

- a rotor including a plurality of movable magnets arranged within or on the rotor, the rotor being configured to rotate about an axis of rotation;
- a stator including a plurality of stationary magnets arranged within or on the stator;

wherein the plurality of movable magnets and the plurality of stationary magnets are permanent magnets;
 wherein the plurality of movable magnets are square magnets or rectangular magnets;

wherein at least one movable magnet of the plurality of movable magnets defines a first axis bisecting the movable magnet through a first pair of edges of the movable magnet and a second axis bisecting the movable magnet through a second pair of edges of the movable magnet; and

wherein the first axis and the second axis do not intersect the axis of rotation.

6. The magnetically-coupled torque-assist device according to claim 5, wherein each movable magnet of the plurality of movable magnets defines a first axis bisecting the respective movable magnet through a first pair of edges of the respective movable magnet and a second axis bisecting the respective movable magnet through a second pair of edges of the respective movable magnet; and

wherein the first axis and the second axis of each of the plurality of movable magnets do not intersect the axis of rotation.

7. A magnetically-coupled torque-assist device, comprising:

a rotor including a plurality of movable magnets arranged within or on the rotor;

a stator including a plurality of stationary magnets arranged within or on the stator;

wherein the plurality of movable magnets and the plurality of stationary magnets are permanent magnets;
 wherein the plurality of movable magnets are square magnets or rectangular magnets;

wherein at least four movable magnets of the plurality of movable magnets each define a first axis bisecting the respective movable magnet through a first pair of edges of the movable magnet and a second axis bisecting the respective movable magnet through a second pair of edges of the movable magnet;

wherein the first axis of a first pair of magnets of the at least four movable magnets are parallel to a rotor axis bisecting the rotor and the first axis of a second pair of magnets of the at least four movable magnets are parallel to a second rotor axis bisecting the rotor; and
 wherein the first rotor axis and the second rotor axis are perpendicular.

* * * * *