



(19) **United States**

(12) **Patent Application Publication**  
**Corman et al.**

(10) **Pub. No.: US 2020/0403323 A1**  
(43) **Pub. Date: Dec. 24, 2020**

(54) **MULTI-BEAM ACTIVE PHASED ARRAY ARCHITECTURE WITH INDEPENDENT POLARIZATION CONTROL**

521, filed on Aug. 17, 2009, provisional application No. 61/265,605, filed on Dec. 1, 2009, provisional application No. 61/222,363, filed on Jul. 1, 2009.

(71) Applicant: **ViaSat, Inc.**, Carlsbad, CA (US)

**Publication Classification**

(72) Inventors: **David W. Corman**, Gilbert, AZ (US);  
**Rob Zienkewicz**, Chandler, AZ (US);  
**David R. Saunders**, Scottsdale, AZ (US)

- (51) **Int. Cl.**
  - H01Q 21/22* (2006.01)
  - H04B 7/10* (2006.01)
  - H04B 7/185* (2006.01)
  - H04B 7/0408* (2006.01)
  - H04W 72/04* (2006.01)
  - H01Q 3/26* (2006.01)
  - H01Q 1/27* (2006.01)
  - H01Q 1/28* (2006.01)
  - H01Q 15/24* (2006.01)
  - H01Q 3/36* (2006.01)

(21) Appl. No.: **17/012,465**

(22) Filed: **Sep. 4, 2020**

**Related U.S. Application Data**

(63) Continuation of application No. 16/674,881, filed on Nov. 5, 2019, now Pat. No. 10,797,406, which is a continuation of application No. 16/284,529, filed on Feb. 25, 2019, now Pat. No. 10,516,219, which is a continuation of application No. 15/804,818, filed on Nov. 6, 2017, now Pat. No. 10,305,199, which is a continuation of application No. 15/212,111, filed on Jul. 15, 2016, now Pat. No. 9,843,107, which is a continuation of application No. 14/617,630, filed on Feb. 9, 2015, now Pat. No. 9,425,890, which is a continuation of application No. 14/216,760, filed on Mar. 17, 2014, now Pat. No. 8,995,943, which is a continuation of application No. 13/692,683, filed on Dec. 3, 2012, now Pat. No. 8,693,970, which is a continuation-in-part of application No. 13/412,901, filed on Mar. 6, 2012, now Pat. No. 8,639,204, which is a continuation of application No. 12/759,059, filed on Apr. 13, 2010, now Pat. No. 8,160,530.

(52) **U.S. Cl.**  
CPC ..... *H01Q 21/22* (2013.01); *H04B 7/10* (2013.01); *H04B 7/18593* (2013.01); *H04B 7/1858* (2013.01); *H04B 7/0408* (2013.01); *H04W 72/0453* (2013.01); *H04W 72/0413* (2013.01); *H01Q 3/26* (2013.01); *H01Q 1/27* (2013.01); *H01Q 1/288* (2013.01); *H04B 7/18515* (2013.01); *H01Q 15/242* (2013.01); *H01Q 3/36* (2013.01); *H04W 72/042* (2013.01)

(60) Provisional application No. 61/237,967, filed on Aug. 28, 2009, provisional application No. 61/259,375, filed on Nov. 9, 2009, provisional application No. 61/234,513, filed on Aug. 17, 2009, provisional application No. 61/222,354, filed on Jul. 1, 2009, provisional application No. 61/168,913, filed on Apr. 13, 2009, provisional application No. 61/259,049, filed on Nov. 6, 2009, provisional application No. 61/234,

(57) **ABSTRACT**

In an exemplary embodiment, a phased array antenna comprises multiple subcircuits in communication with multiple radiating elements. The radio frequency signals are independently adjusted for both polarization control and beam steering. In a receive embodiment, multiple RF signals of various polarizations are received and combined into at least one receive beam output. In a transmit embodiment, at least one transmit beam input is divided and transmitted through multiple radiating elements, with the transmitted beams having various polarizations. In an exemplary embodiment, the phased array antenna provides multi-beam formation over multiple operating frequency bands. The wideband nature of the active components allows for operation over multiple frequency bands simultaneously.

**1-Beam 4-Element Rx Array Chip**

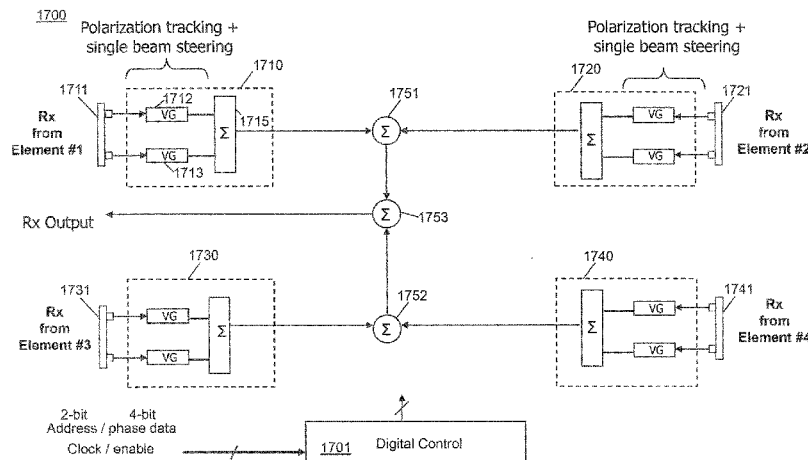

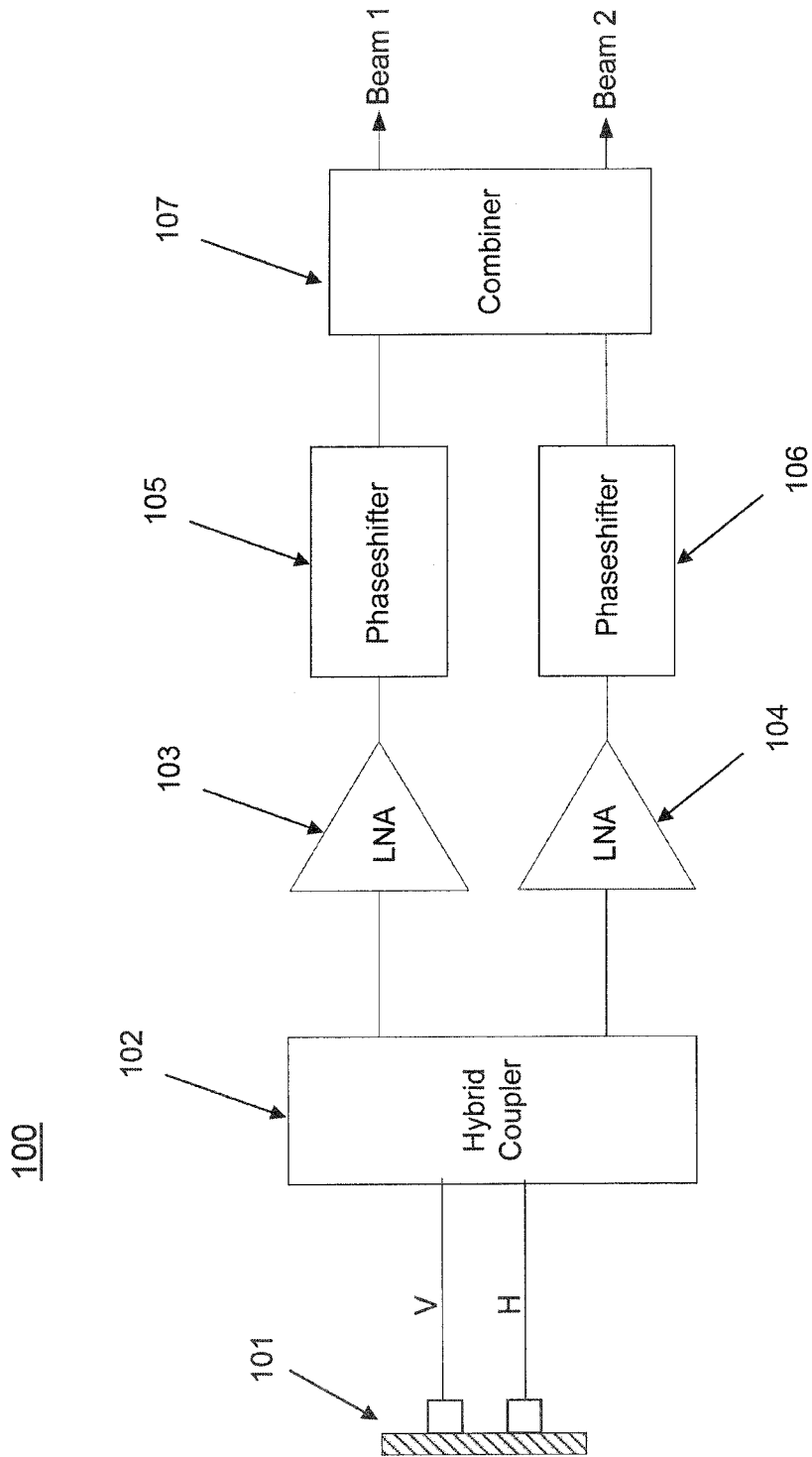

Figure 1  
(Prior Art)

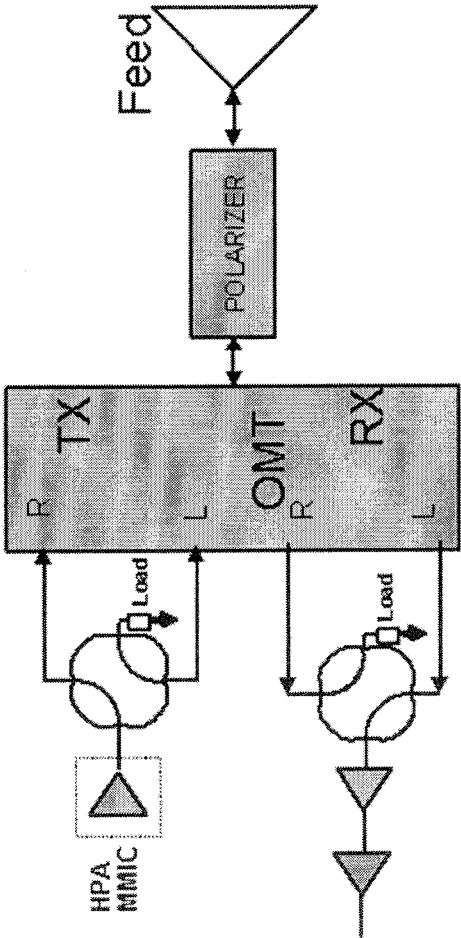

Figure 2  
(Prior Art)

# Active Power Splitter Concept

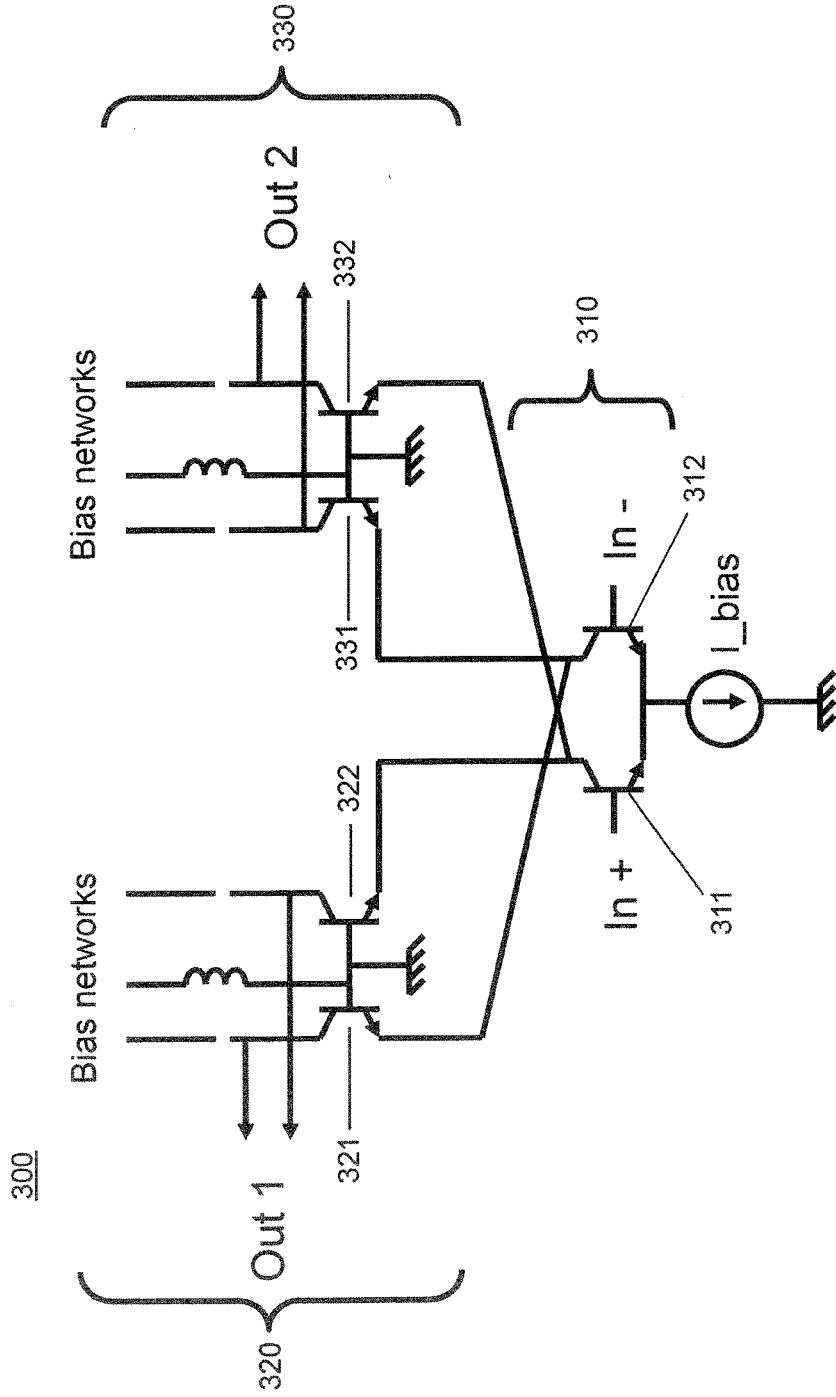

Figure 3

# Active Power Combiner Concept

400

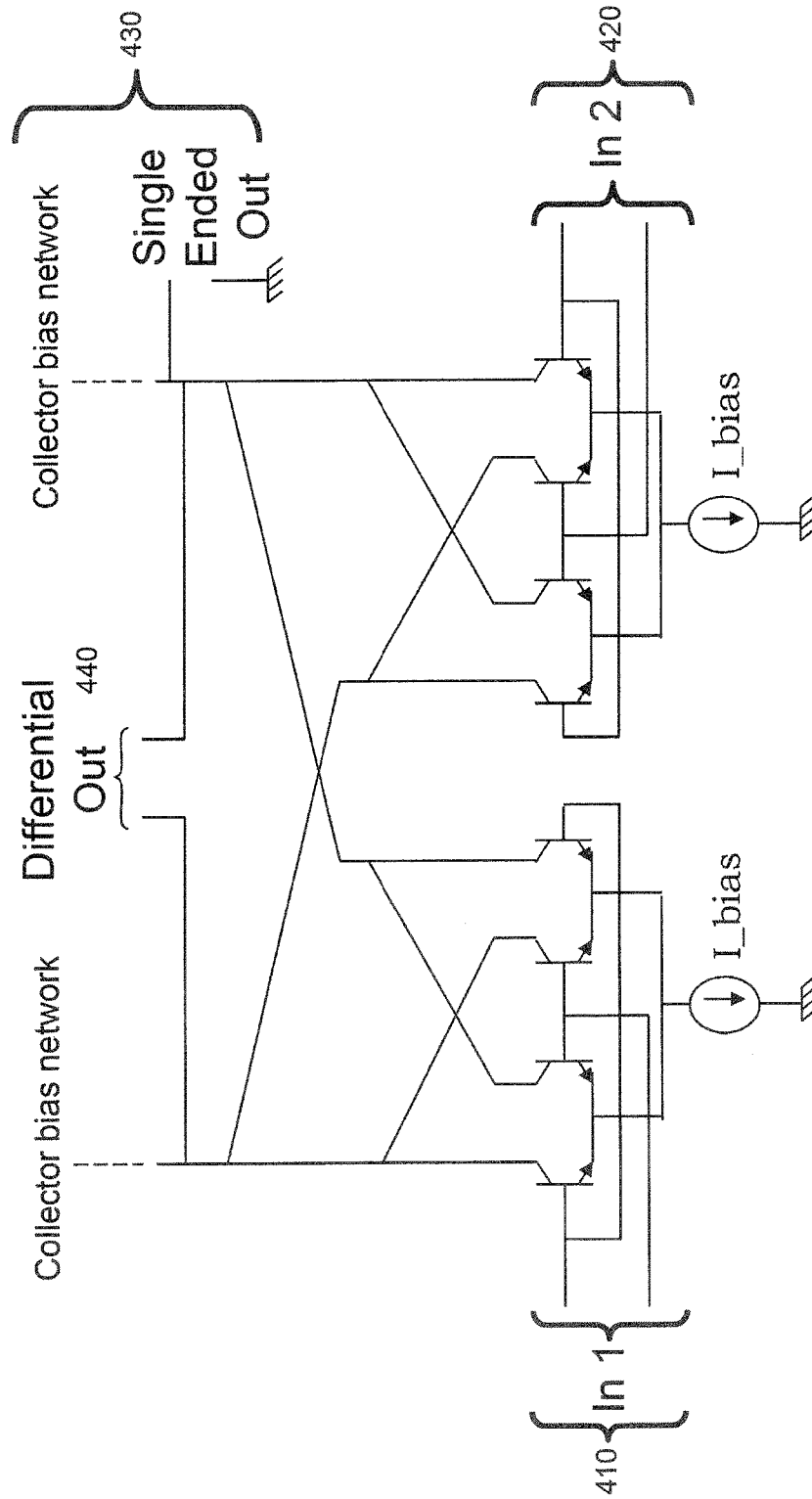

Figure 4

# Active Vector Generator

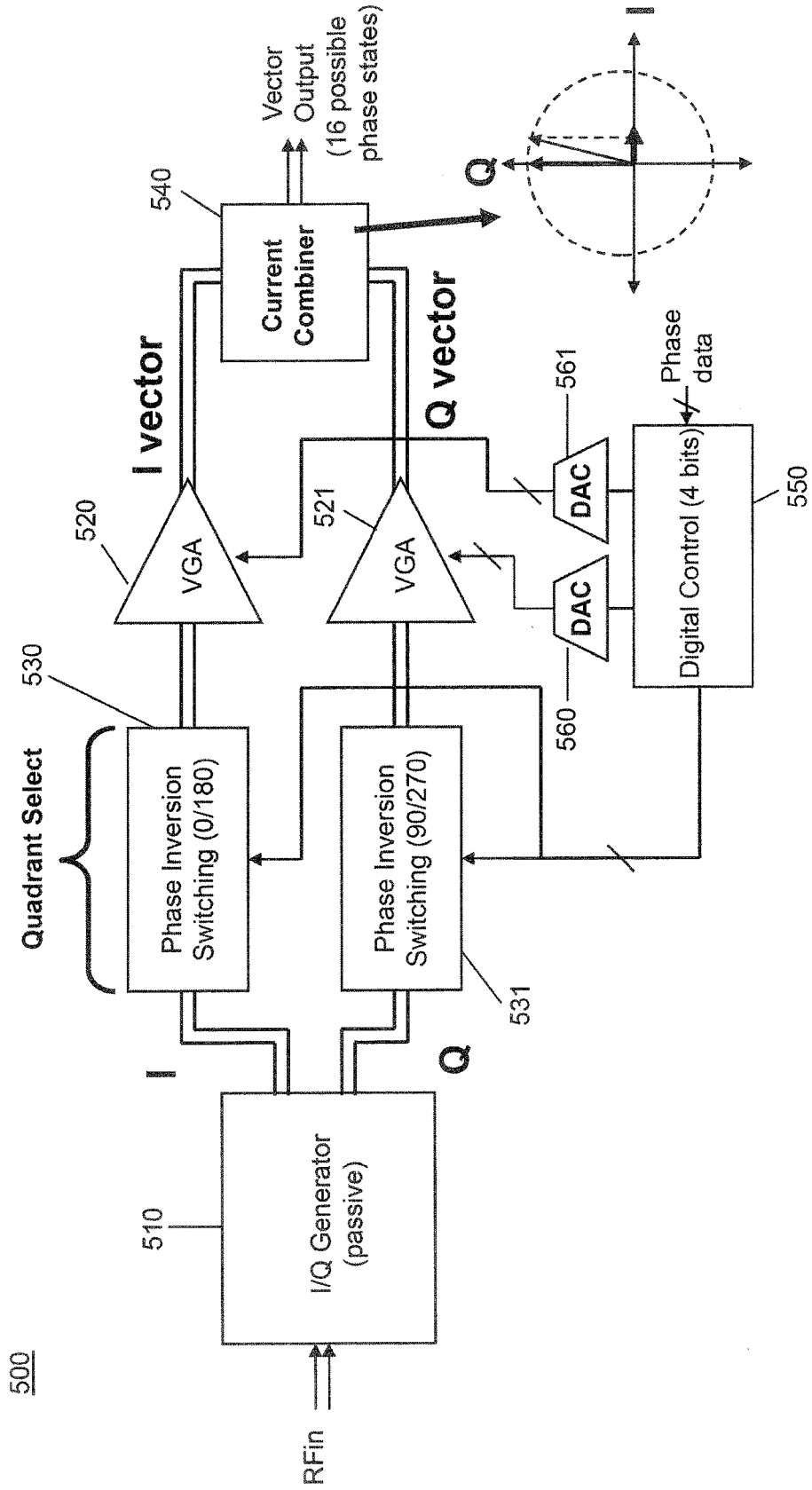

Figure 5

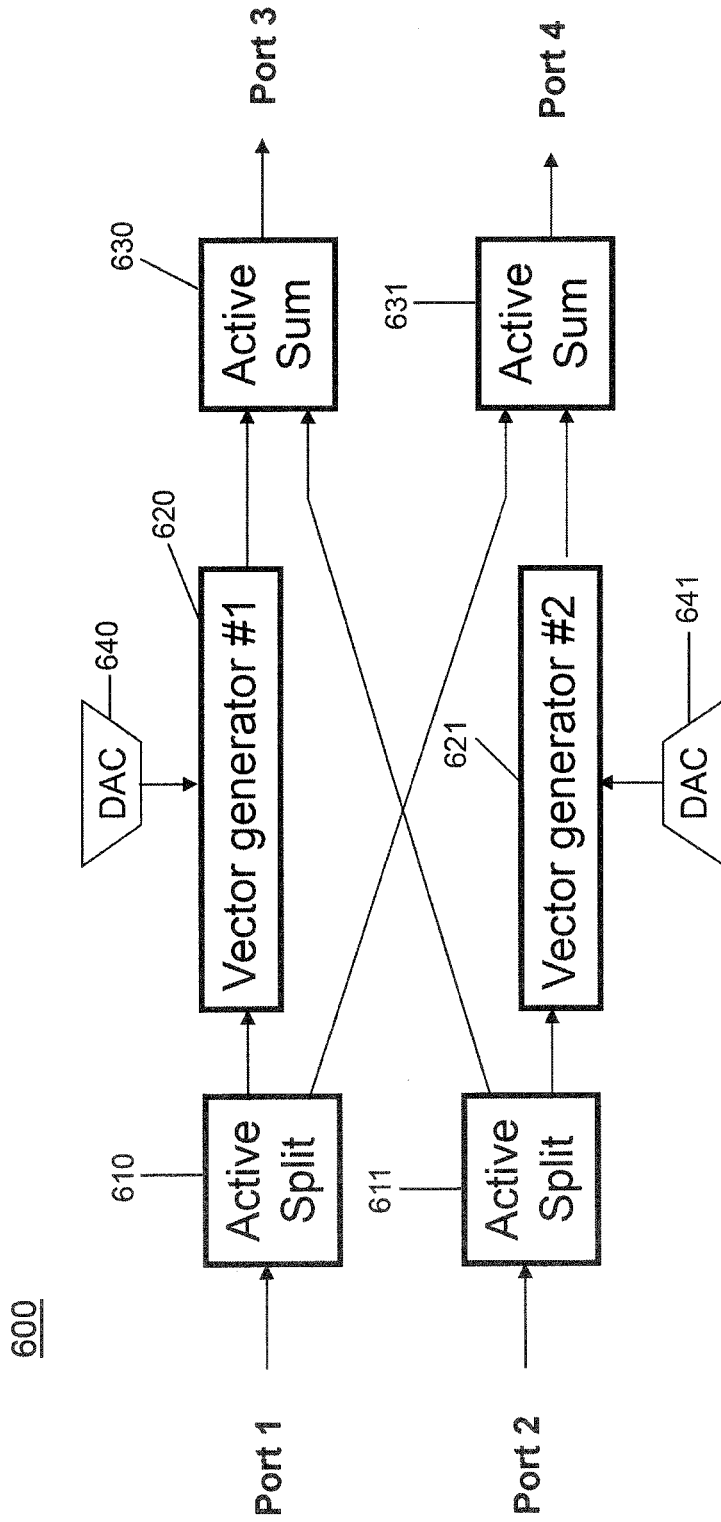

Figure 6

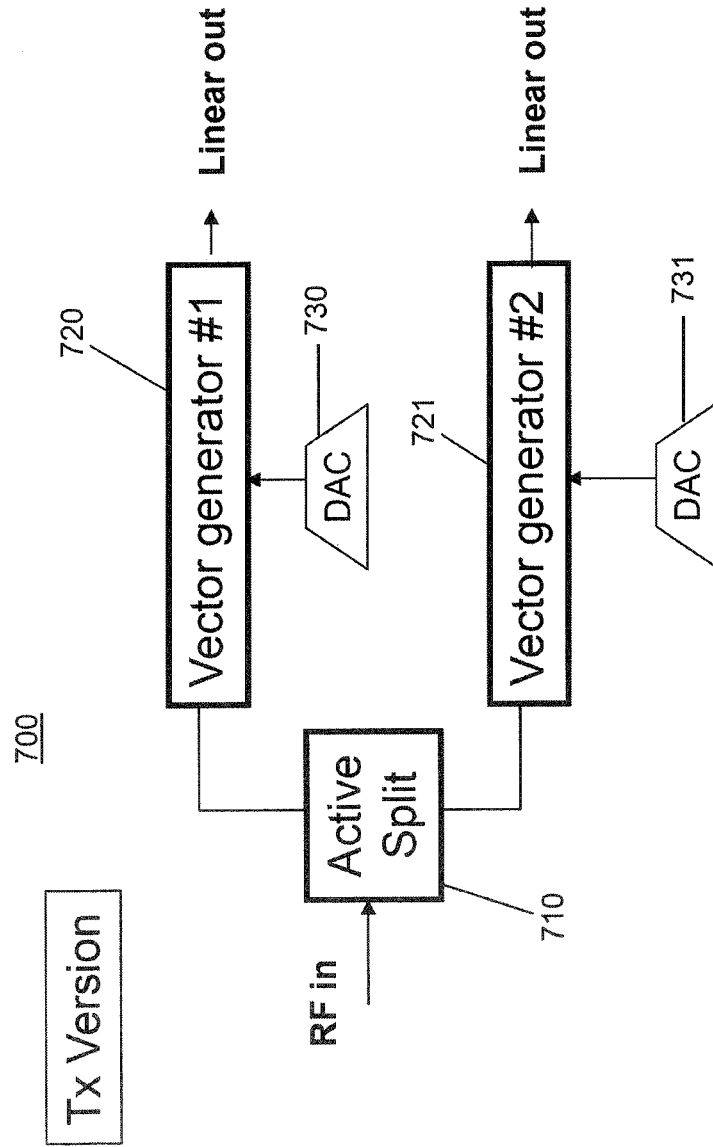

Figure 7



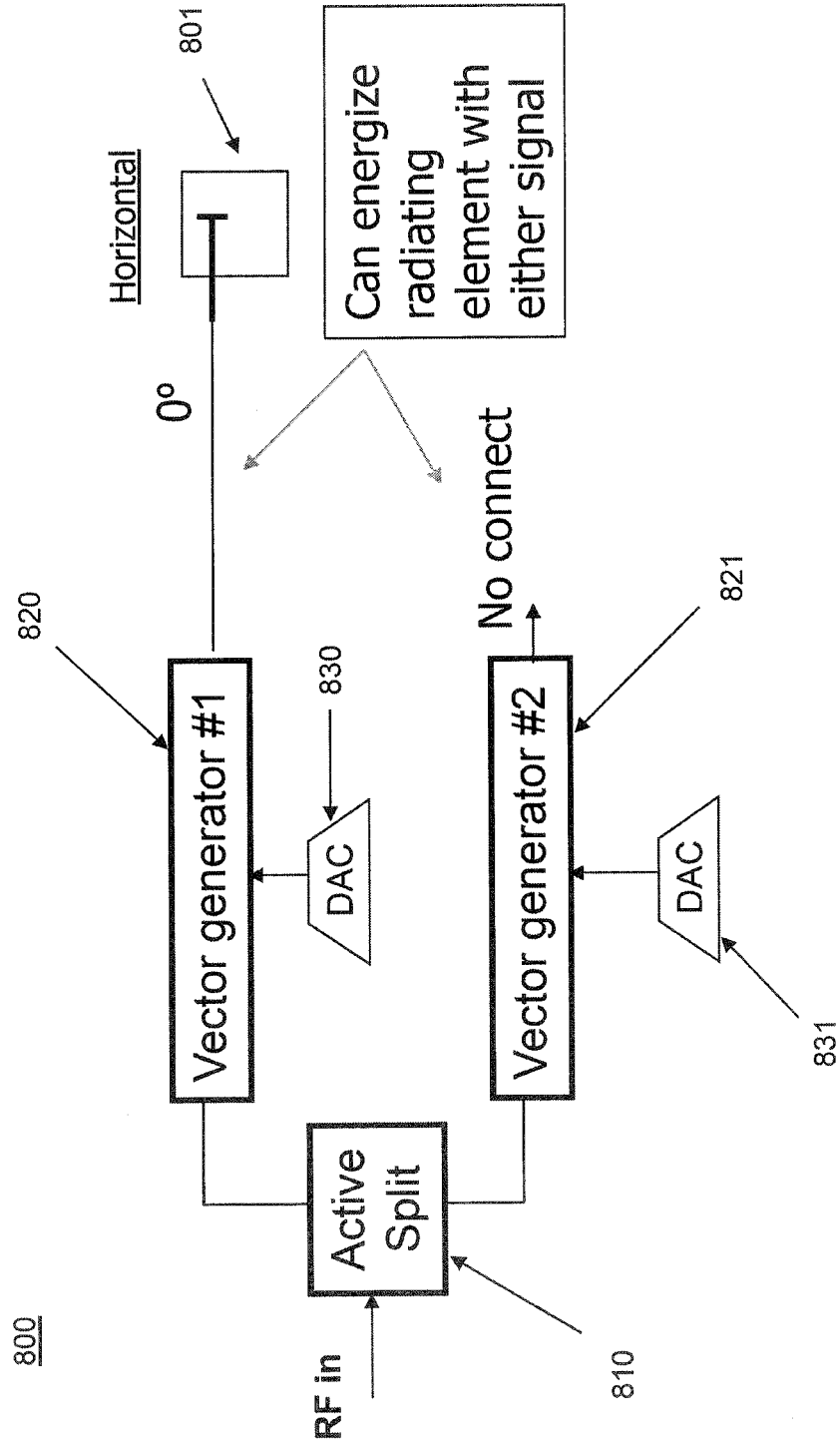

Figure 8

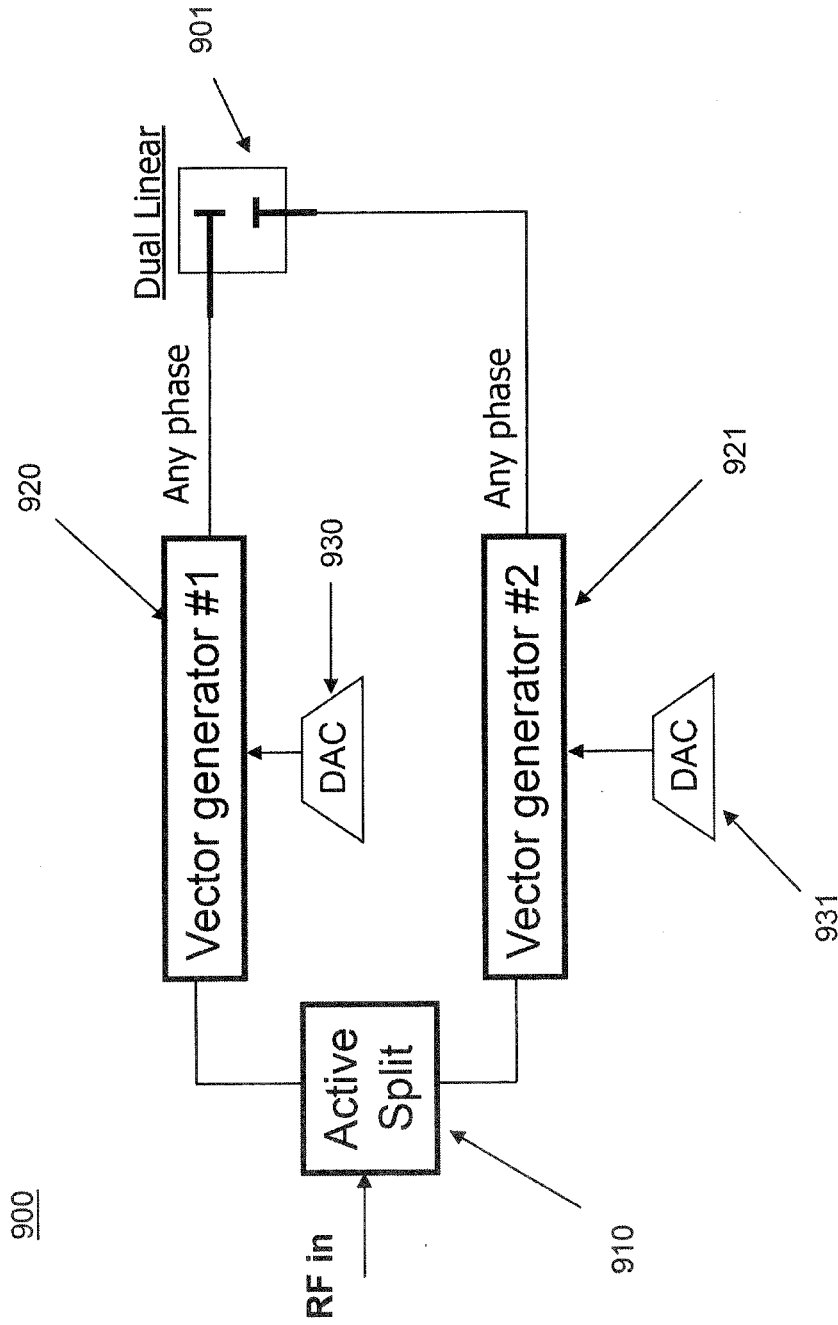

Figure 9

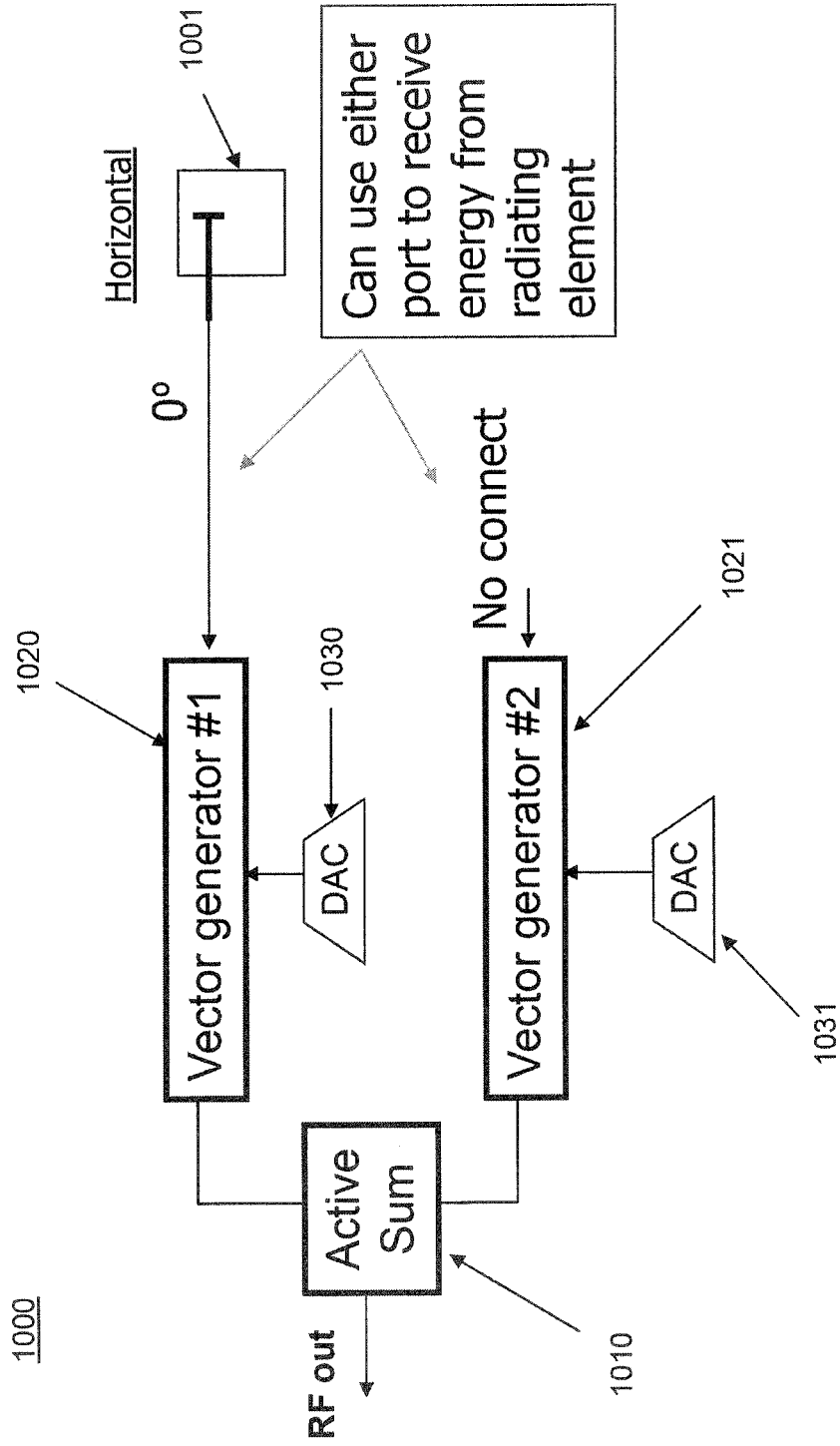

Figure 10

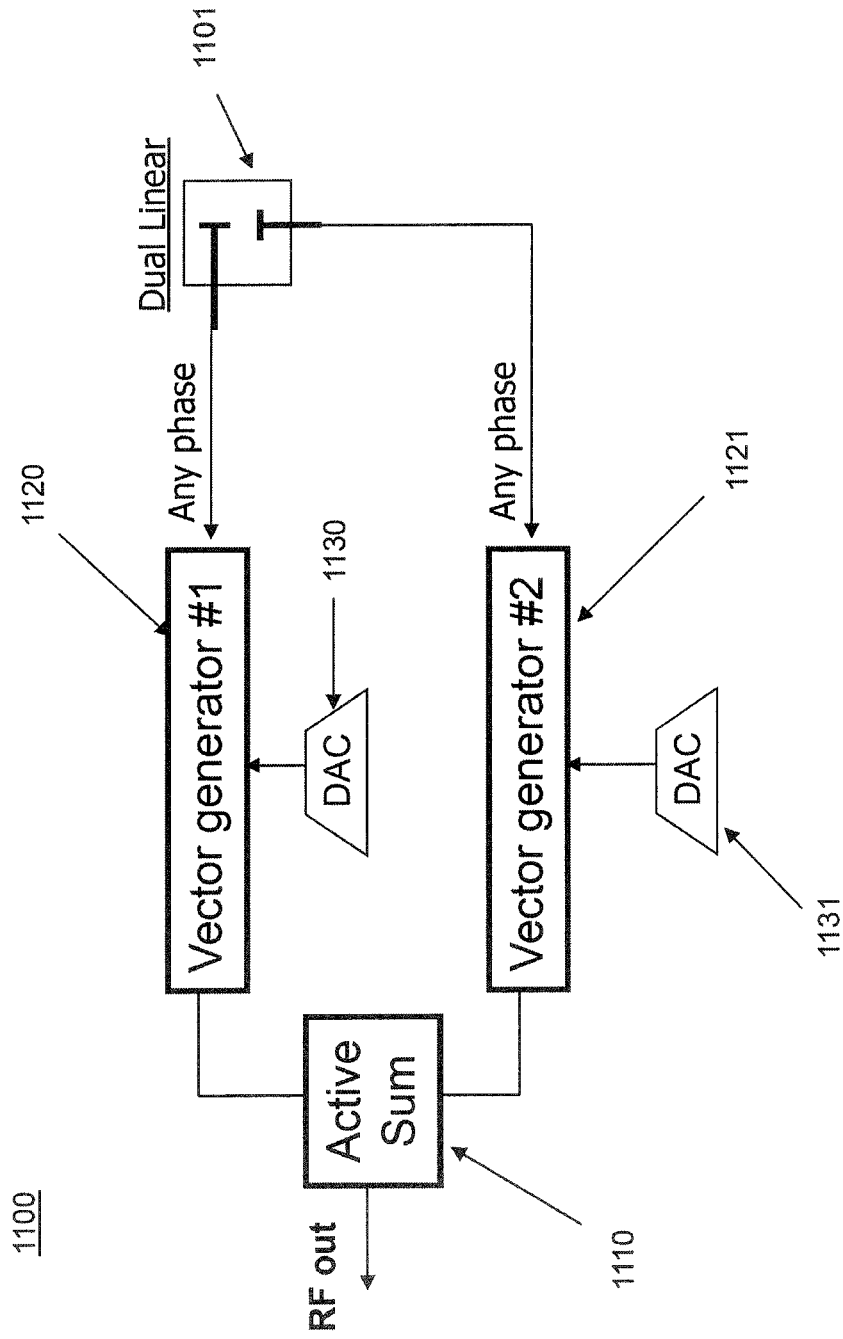

Figure 11

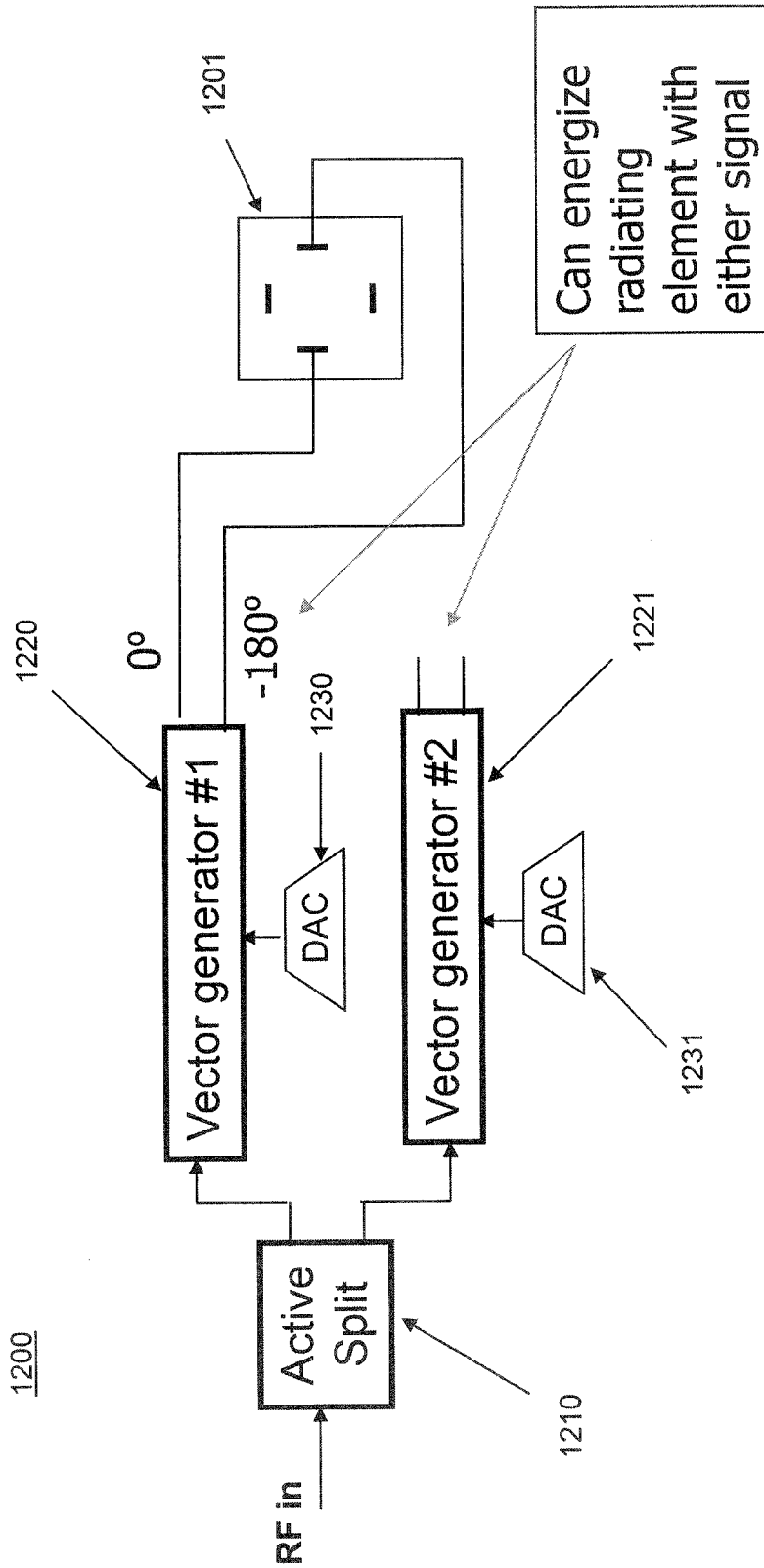

Figure 12

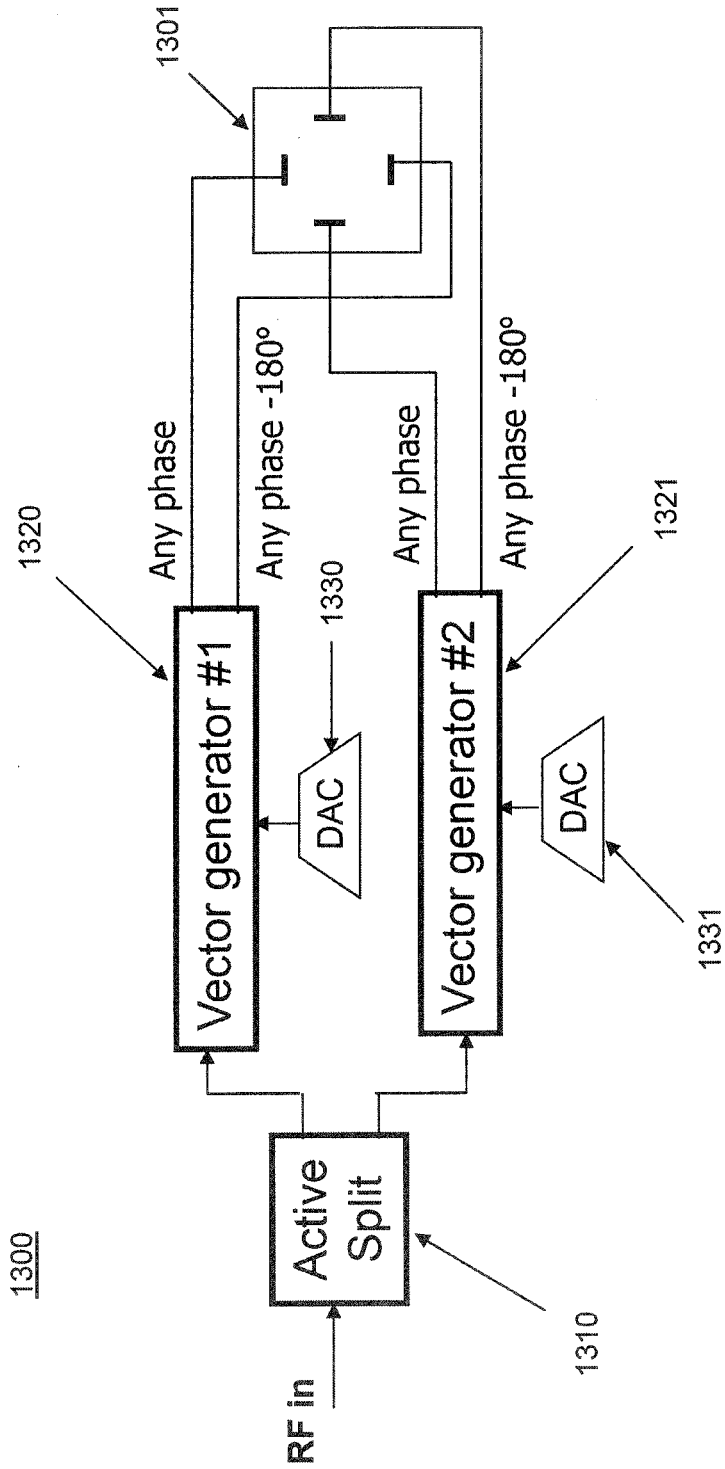

Figure 13

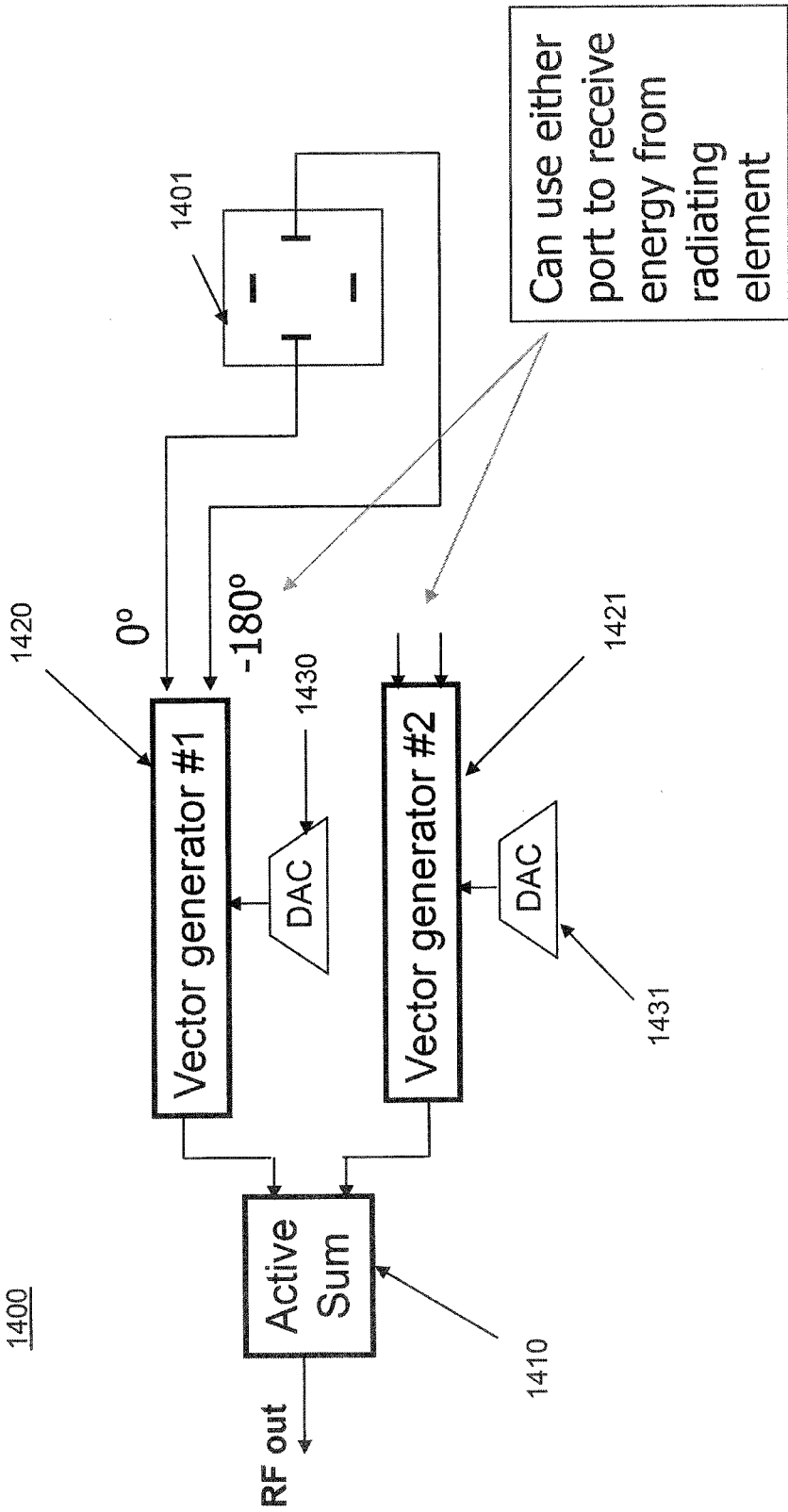

Figure 14

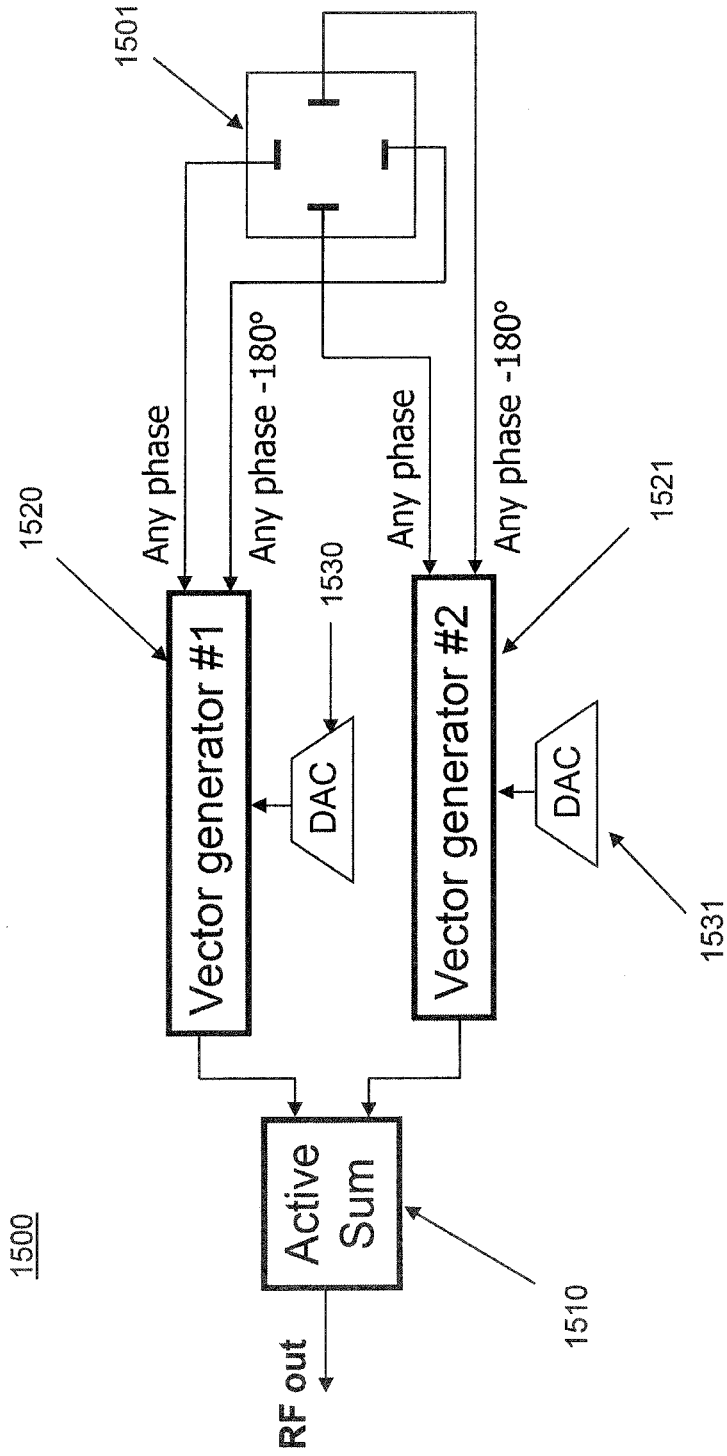

Figure 15



# 1-Beam 4-Element Tx Array Chip

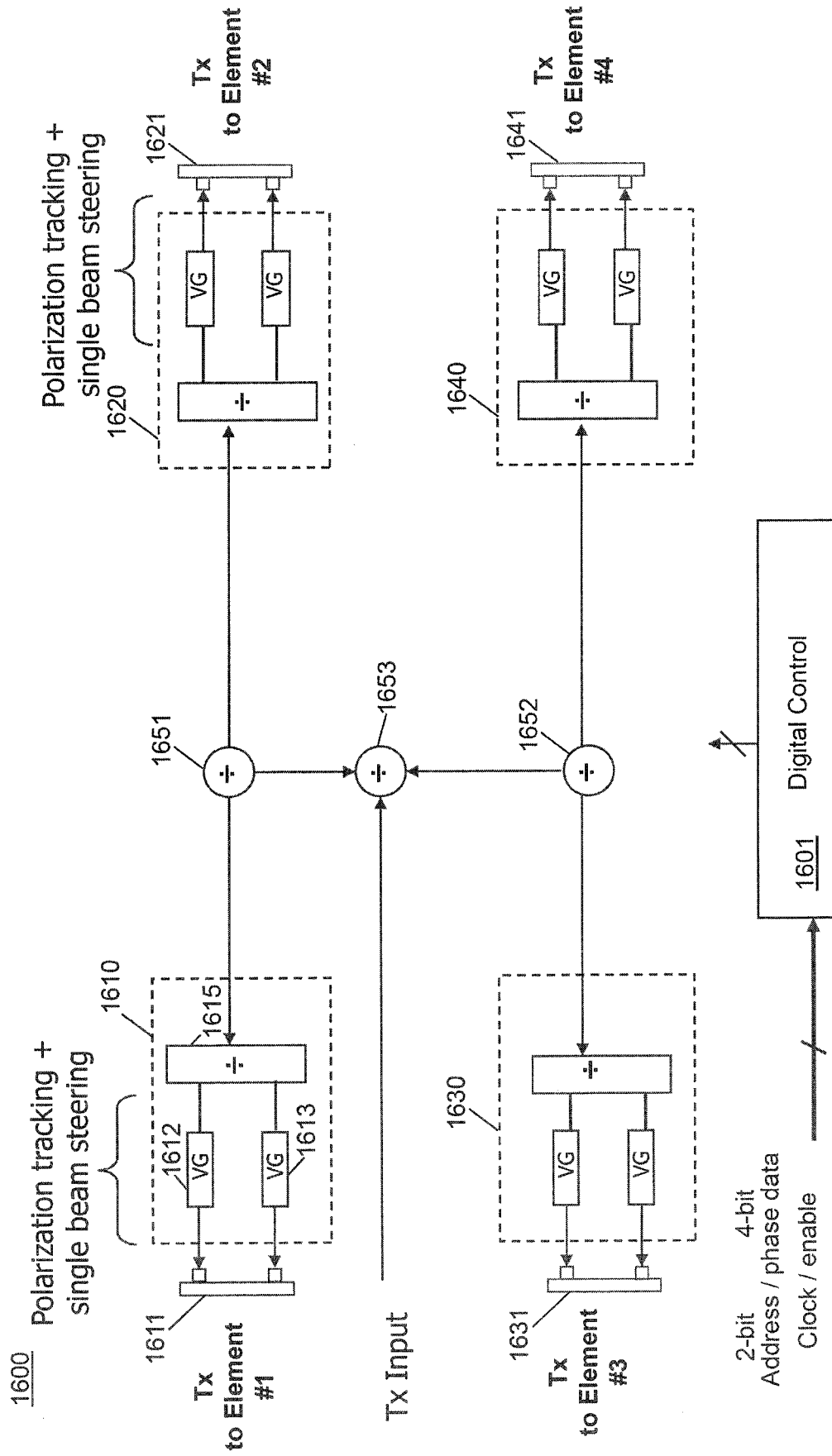

Figure 16

# 1-Beam 4-Element Rx Array Chip

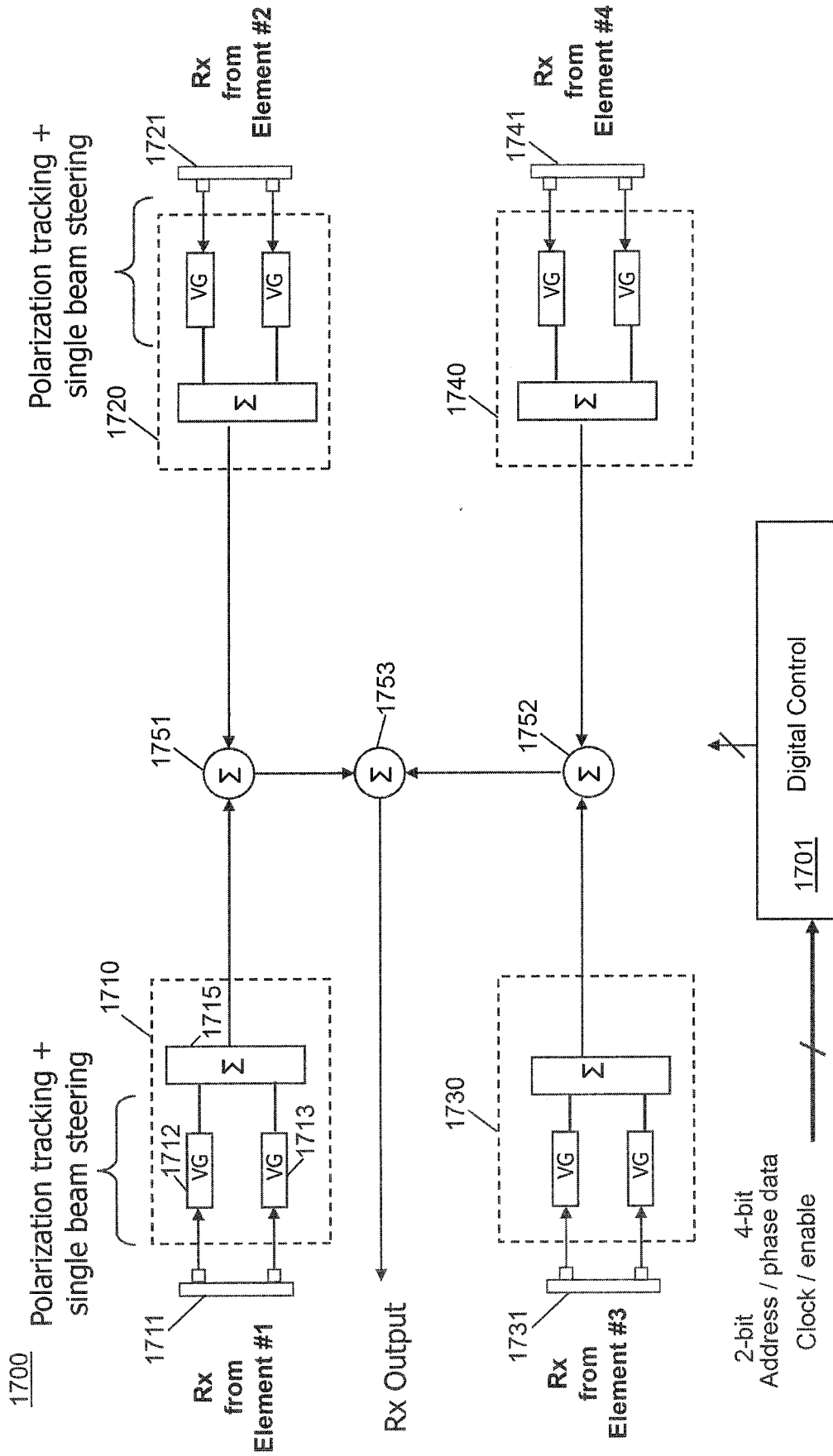

Figure 17

# 2-Beam 4-Element Rx Array Chip

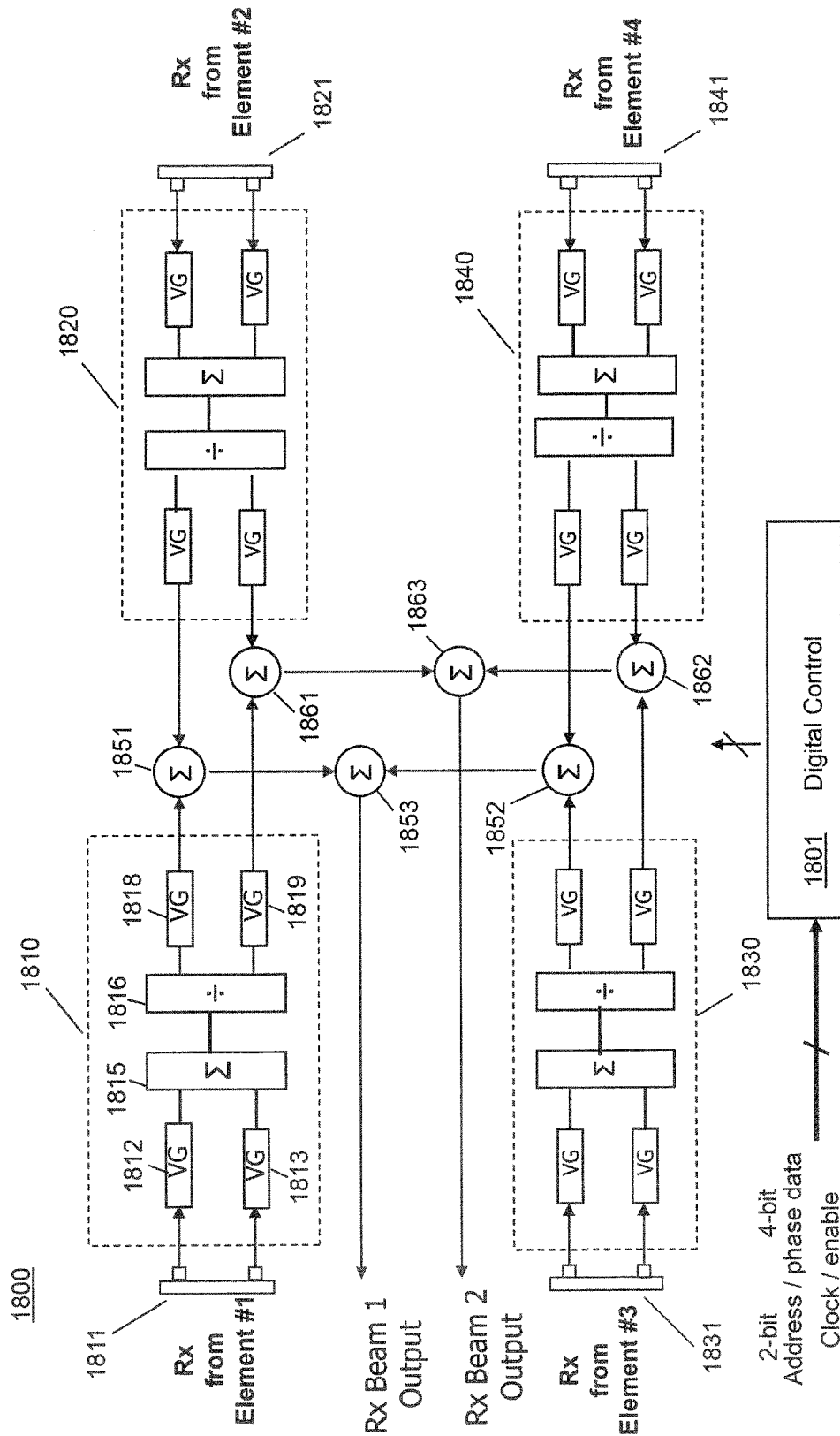

Figure 18

# 2-Beam 4-Element Tx Array Chip

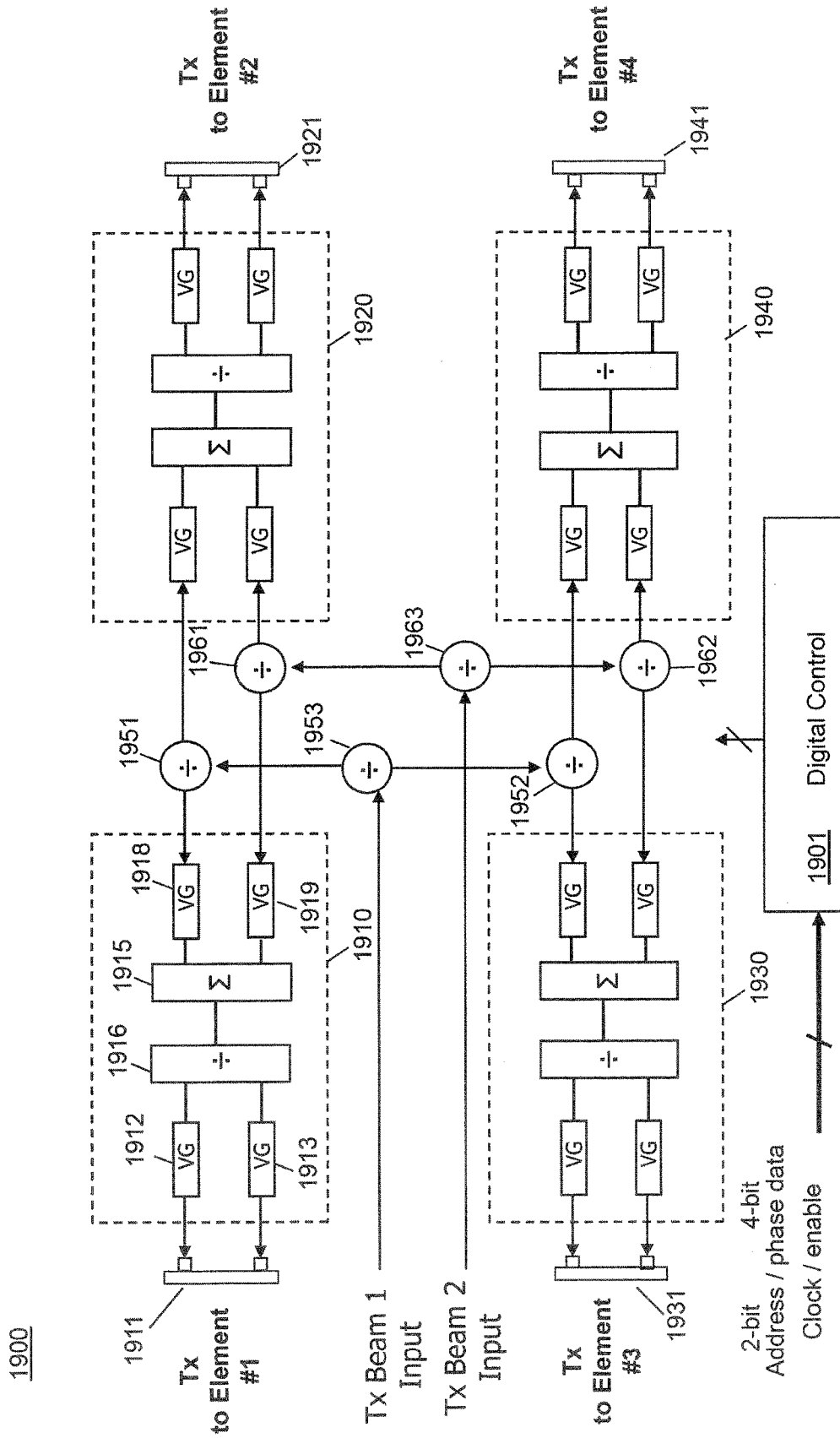

Figure 19

# 4-Beam 4-Element Rx Array Chip

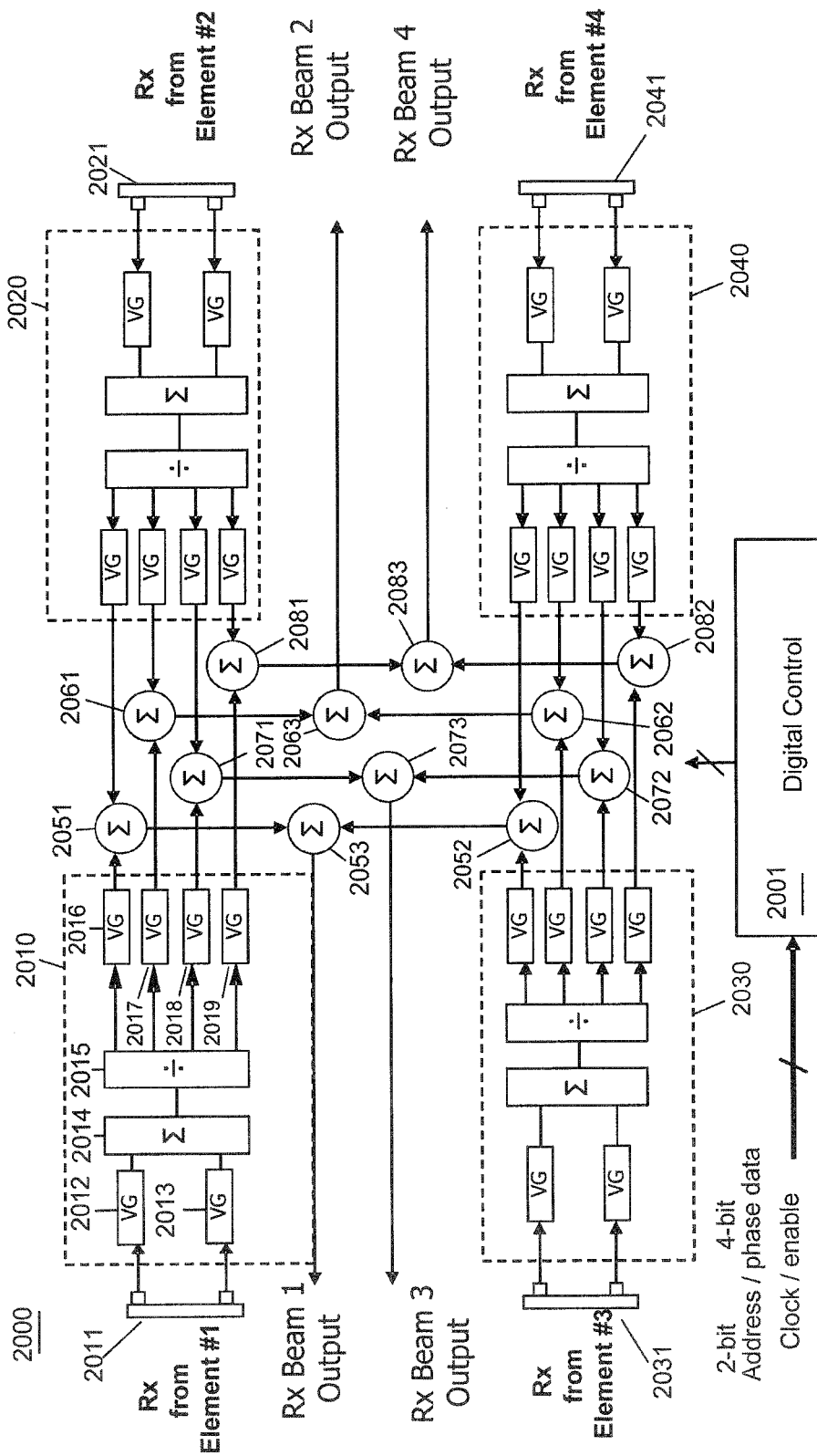

Figure 20

# 4-Beam 4-Element Tx Array Chip

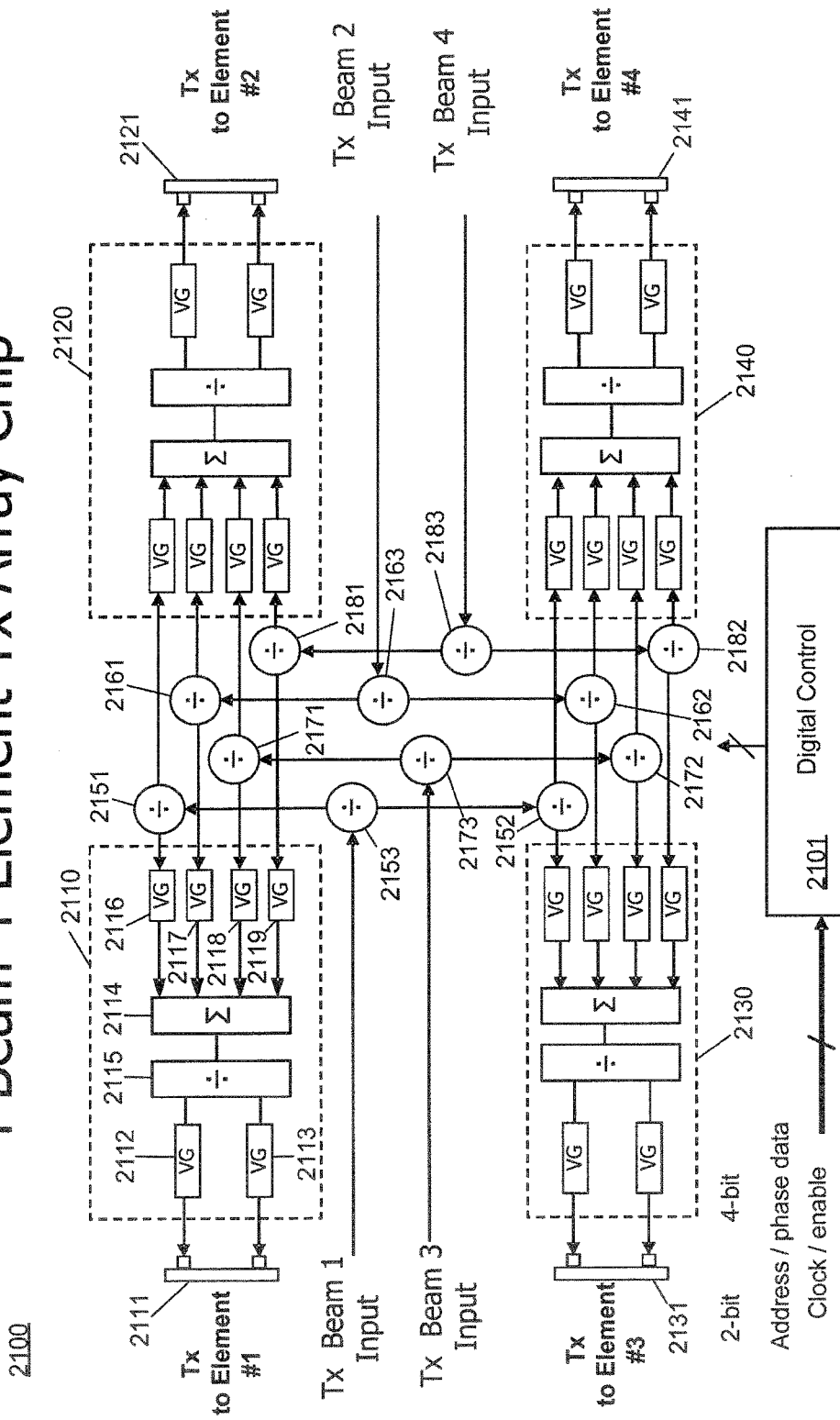

Figure 21

# 2-Beam 4-Element Rx Array Chip – Circular/Elliptical Polarization-Specific Embodiment

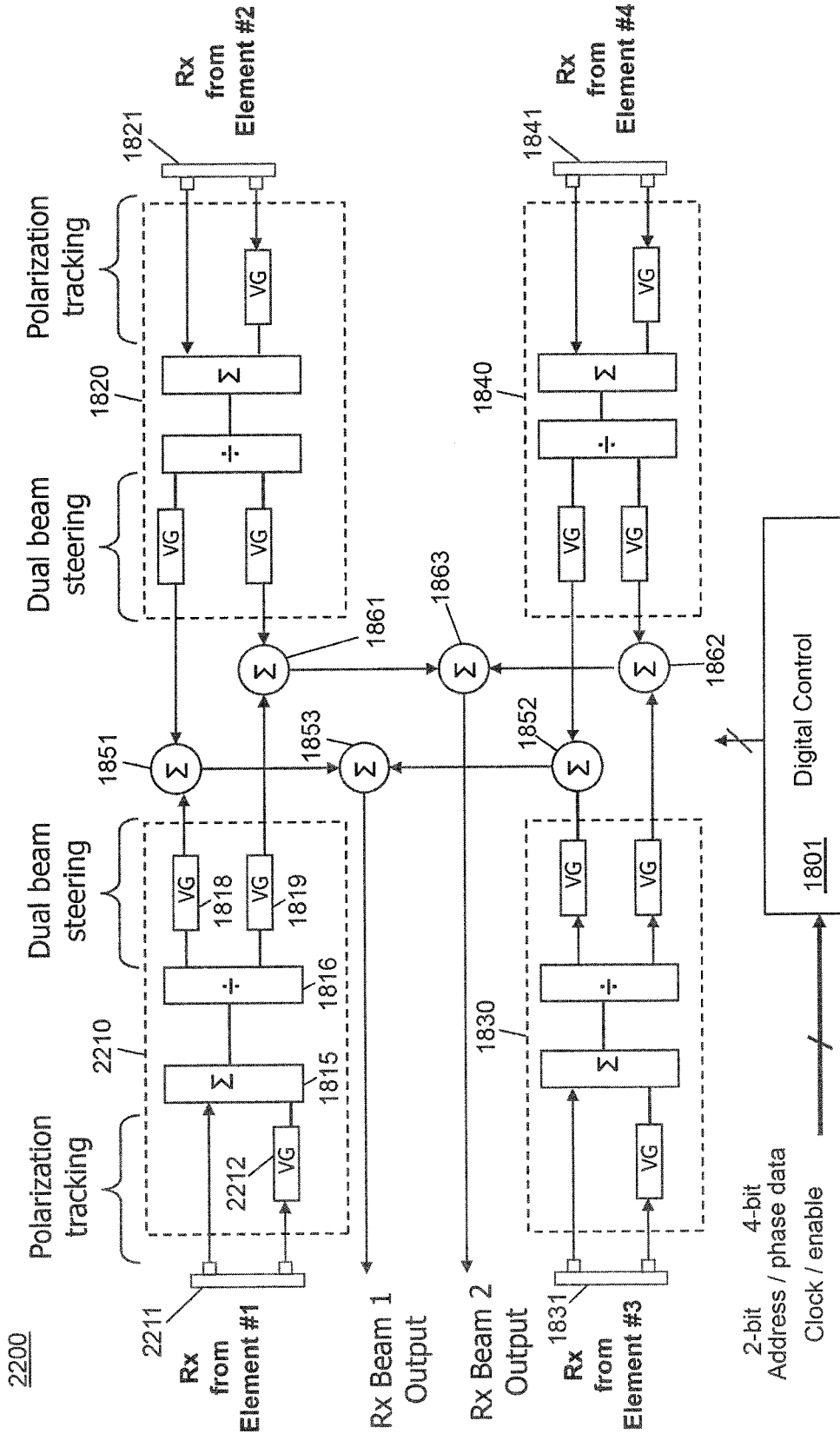

Figure 22

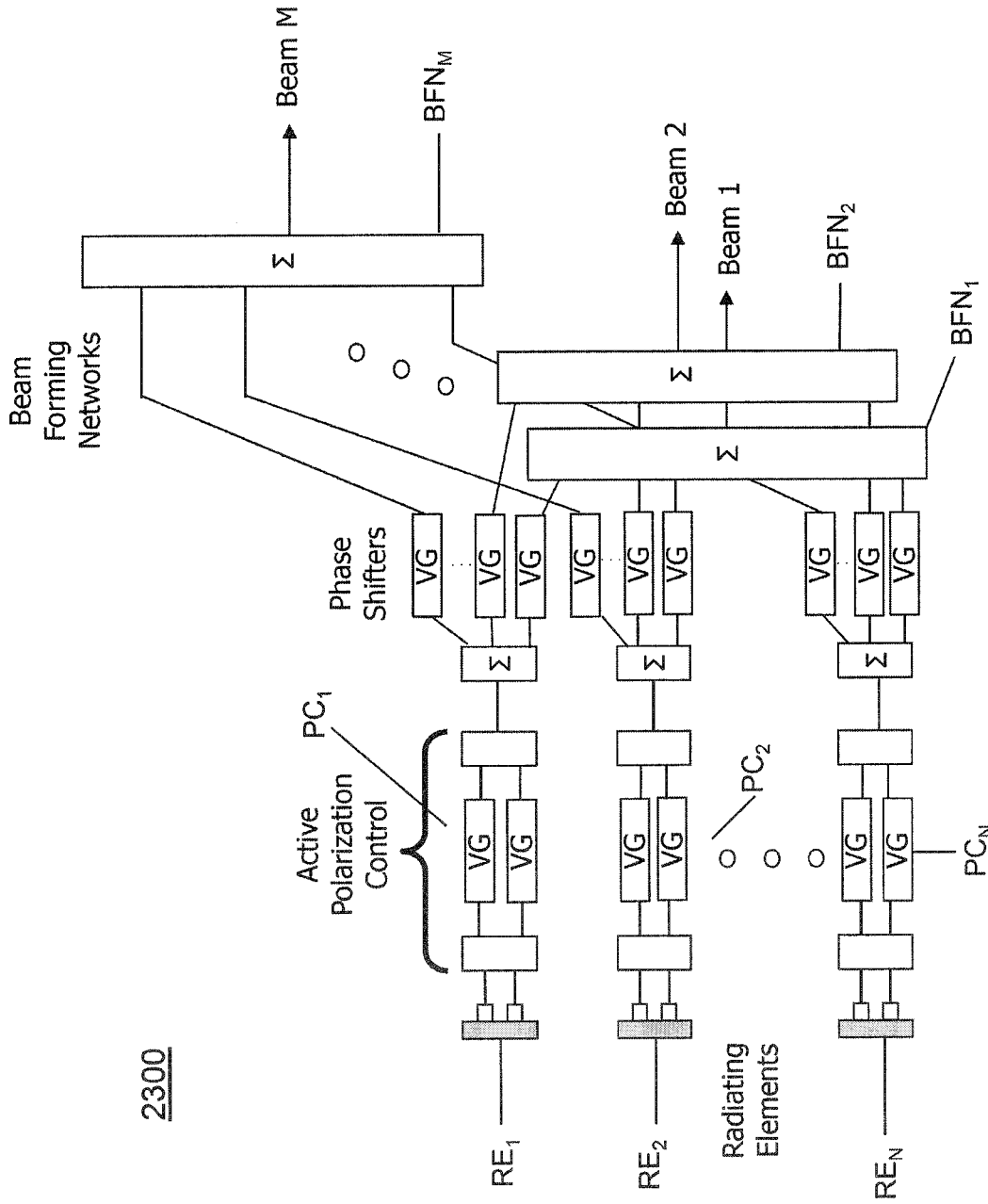

Figure 23



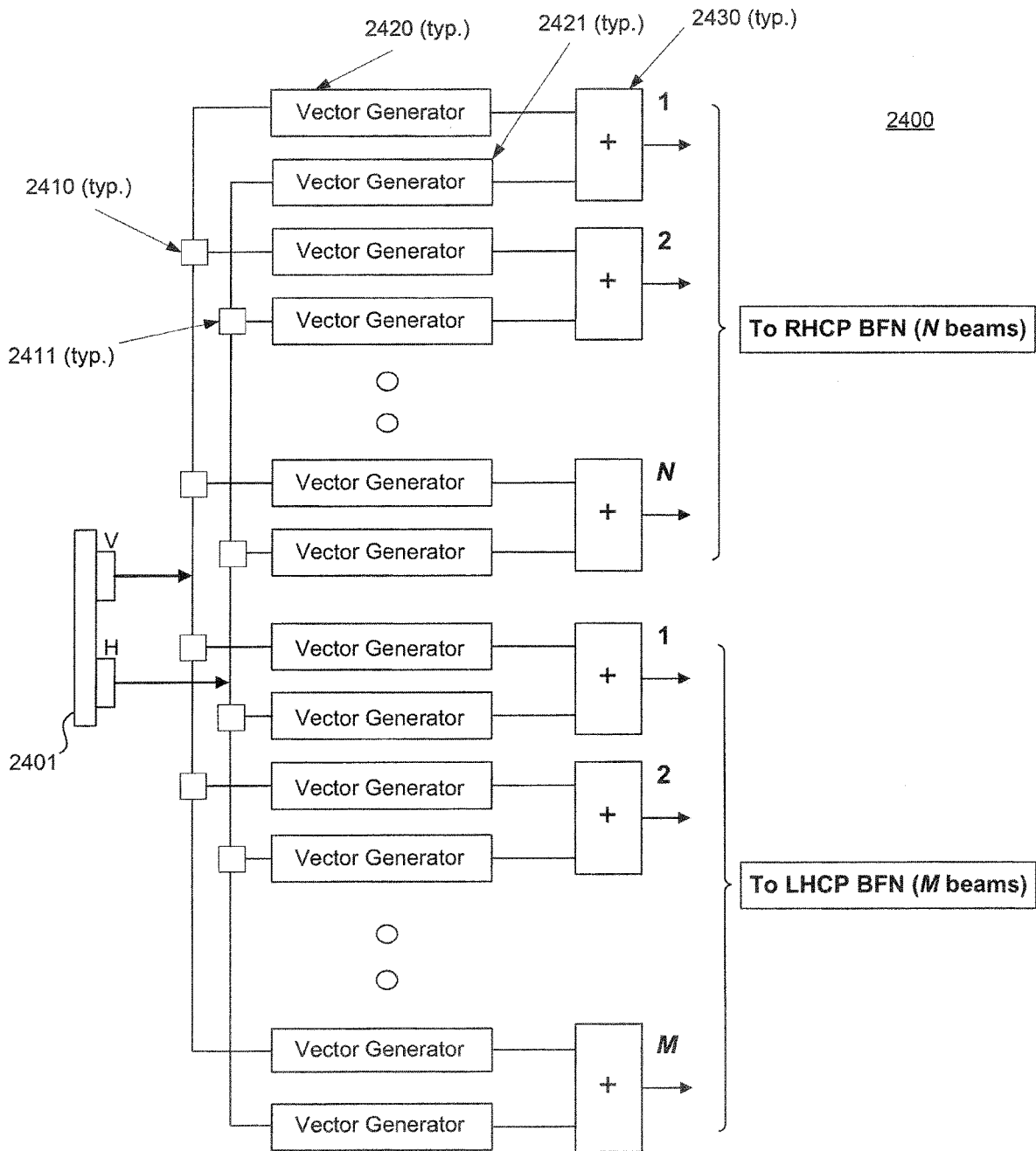

Figure 24

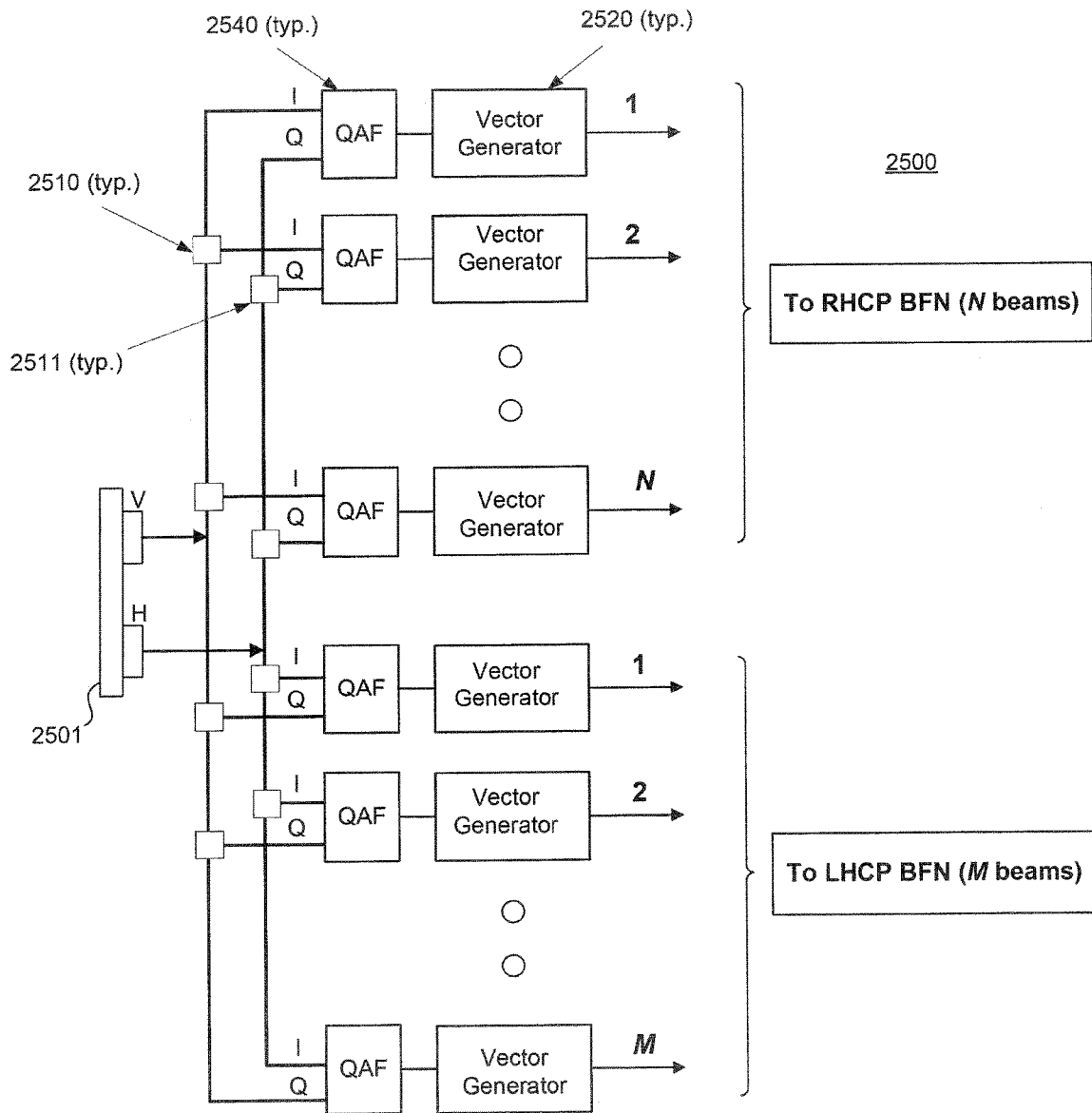

Figure 25

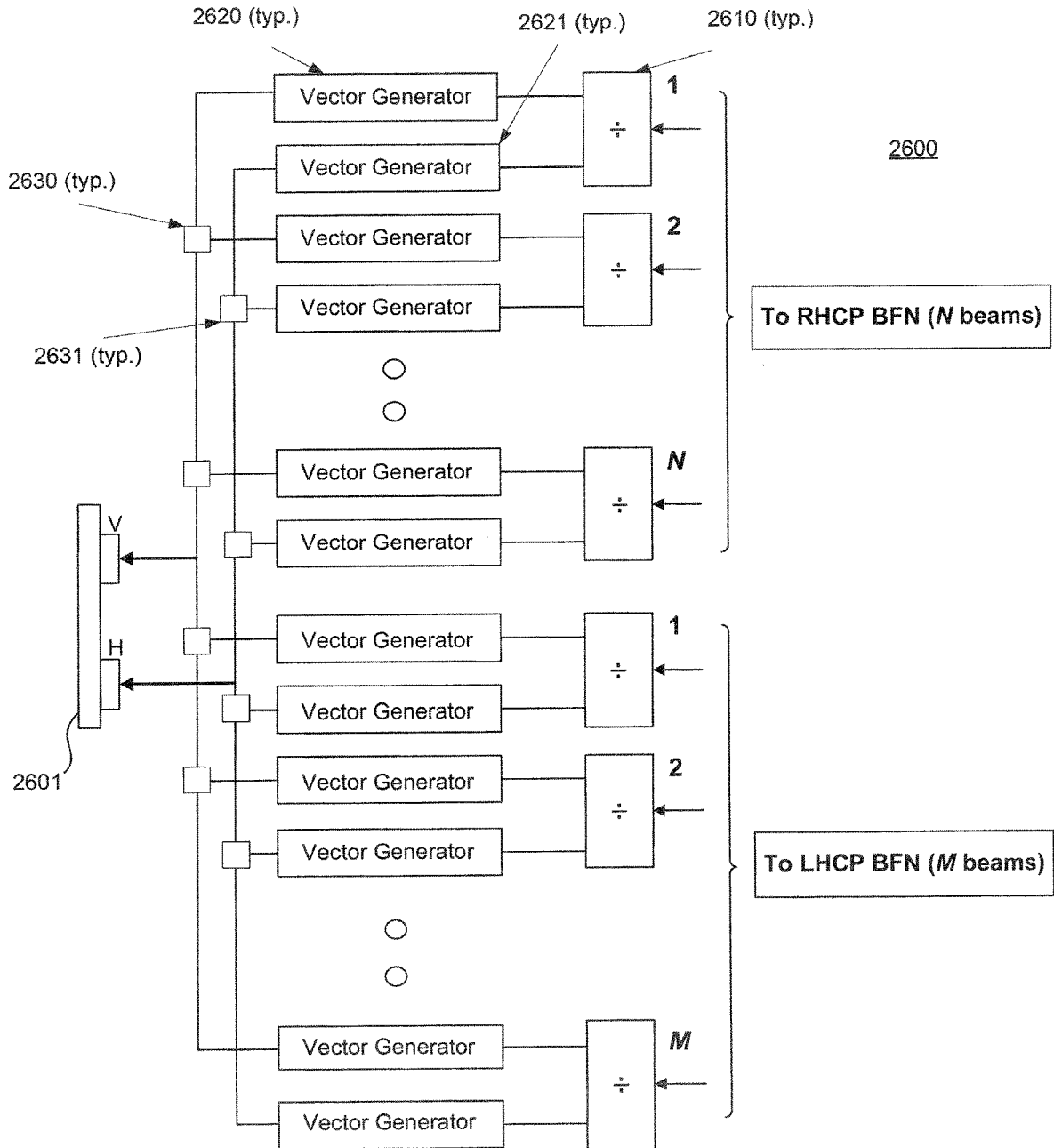

Figure 26

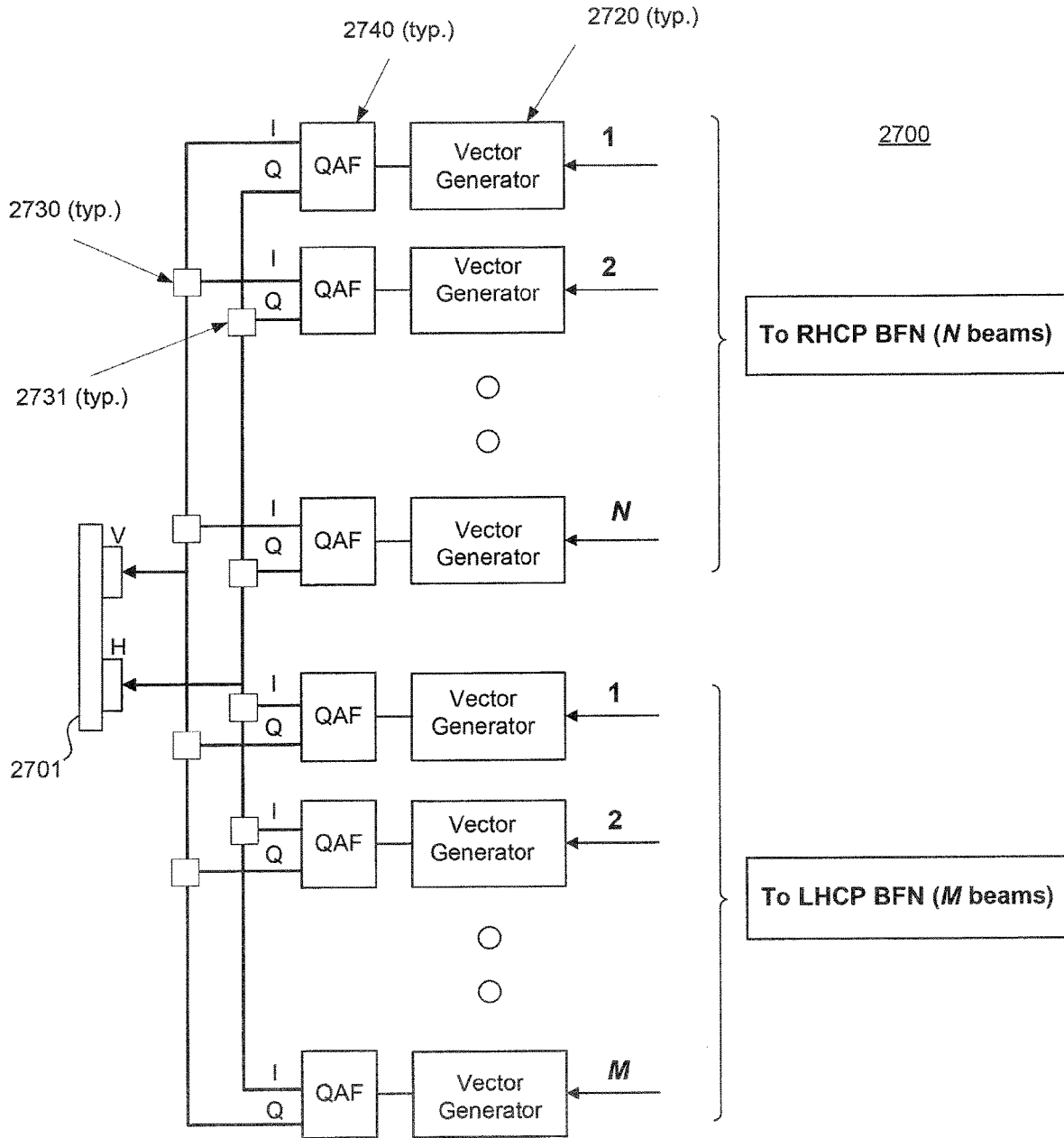

Figure 27

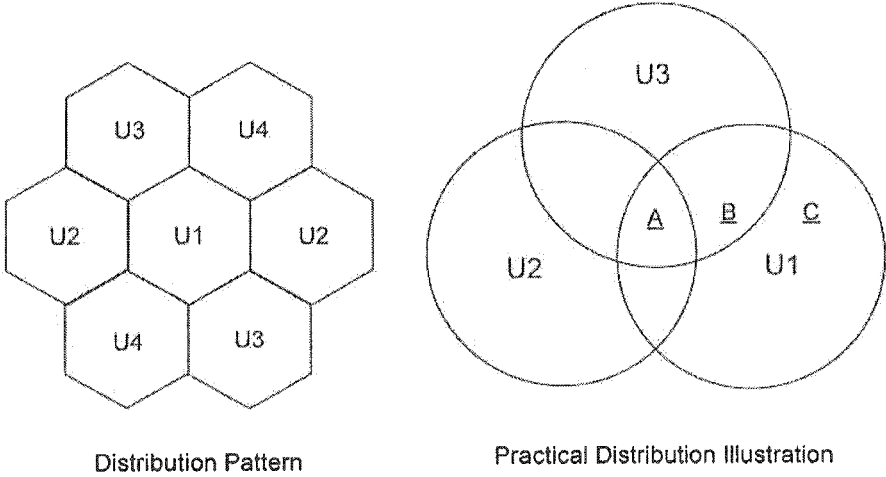
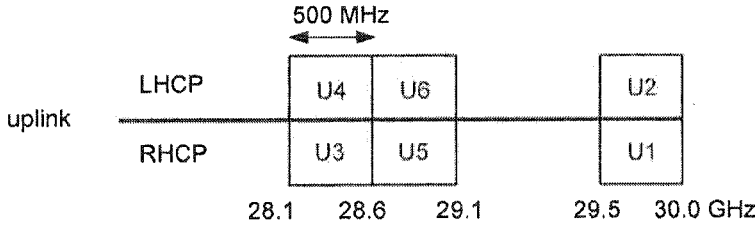
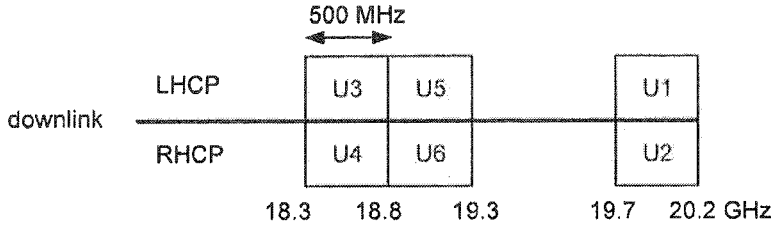

Figure 28

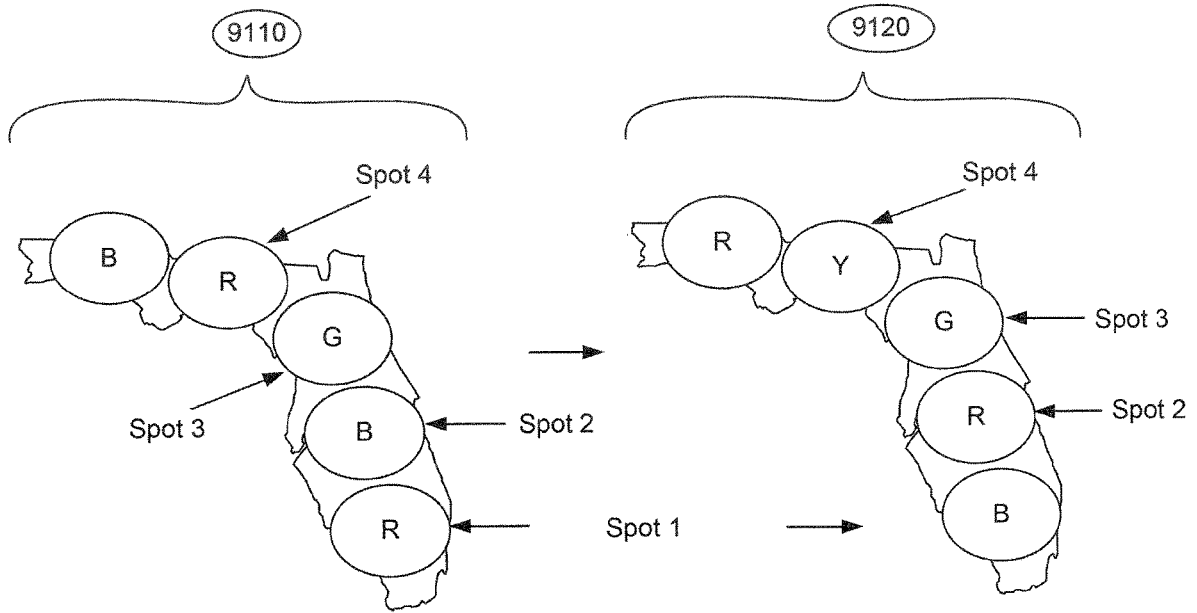

FIGURE 29A

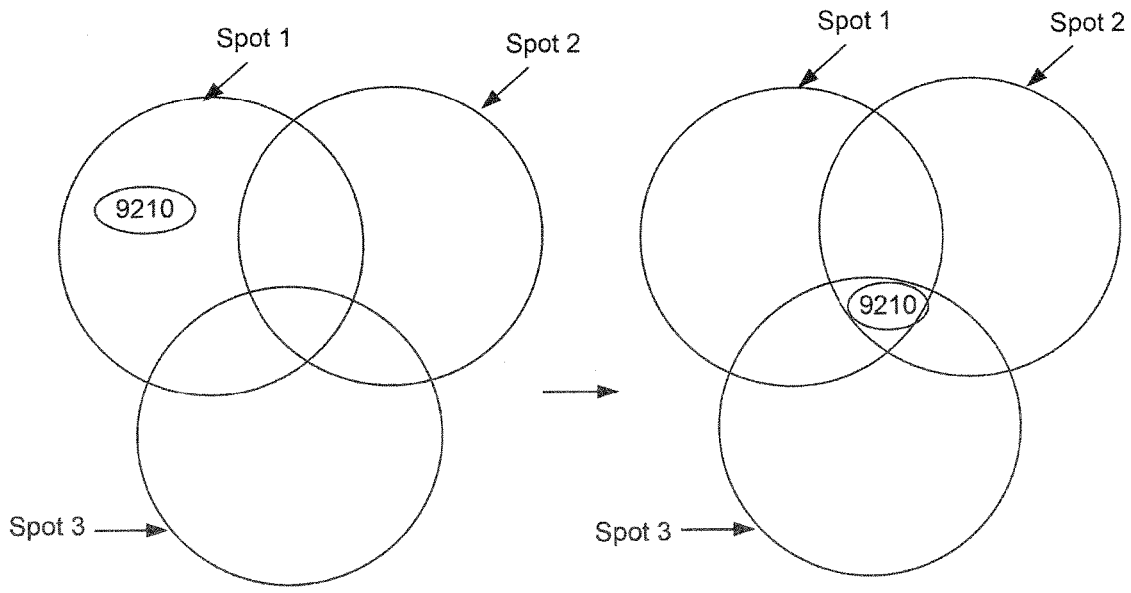
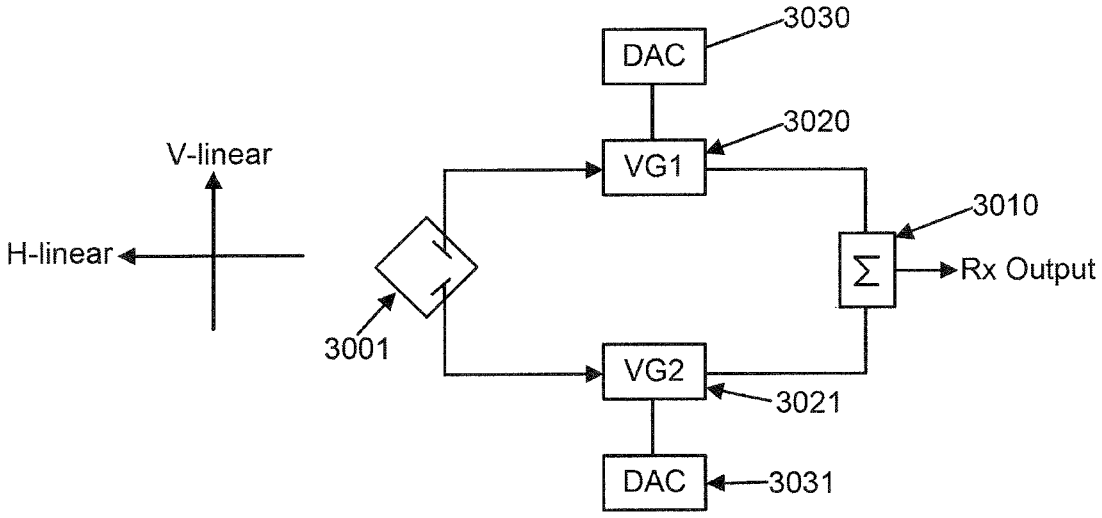

FIGURE 29B

FIGURE 29C

3000



VG1	VG2	Pol
$\ominus$	$\ominus$	H-linear
$\ominus$	$\ominus_{\pm 180}$	V-linear

Fig. 30

3100

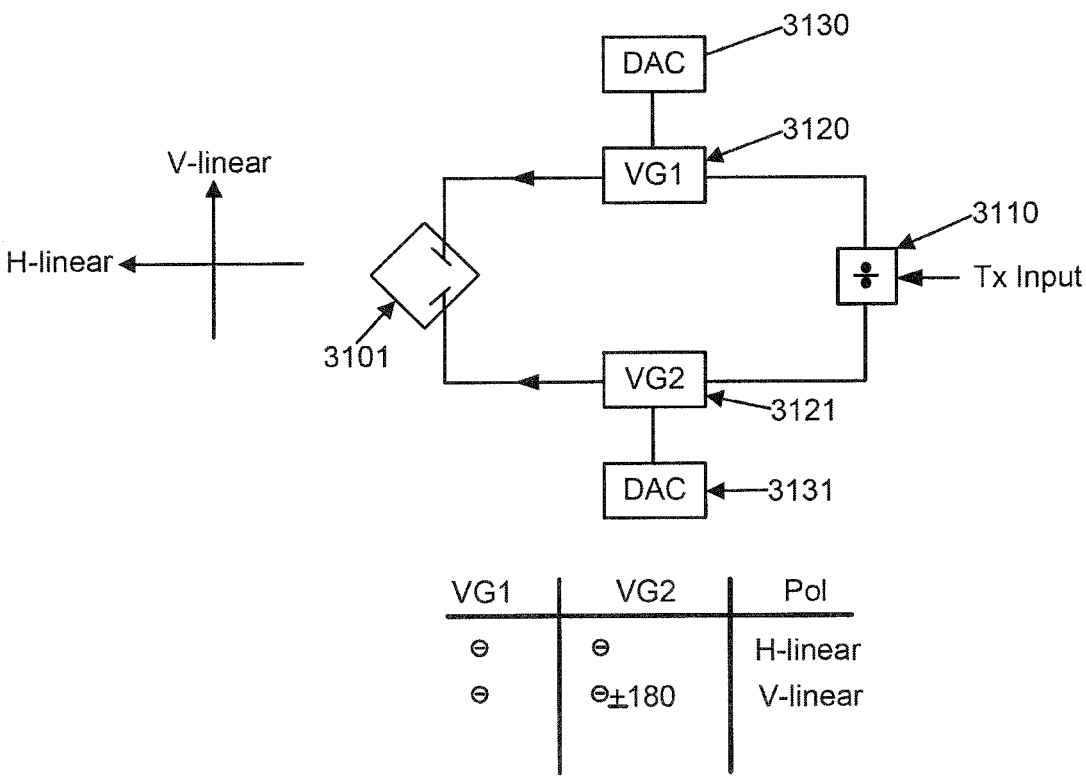
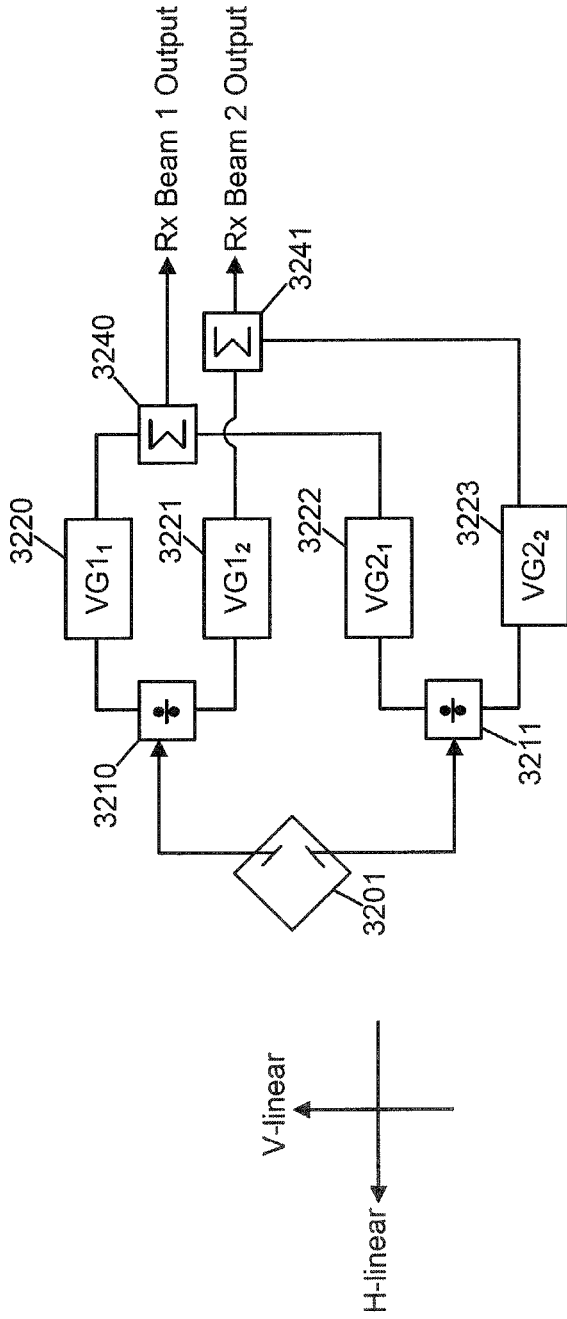

Fig. 31



3200



$n = \text{beam number}$

	VG2 <sub>n</sub>	Pol
VG1 <sub>n</sub>	e	H-linear
e	e <sub>±180</sub>	V-linear

Fig. 32

3300

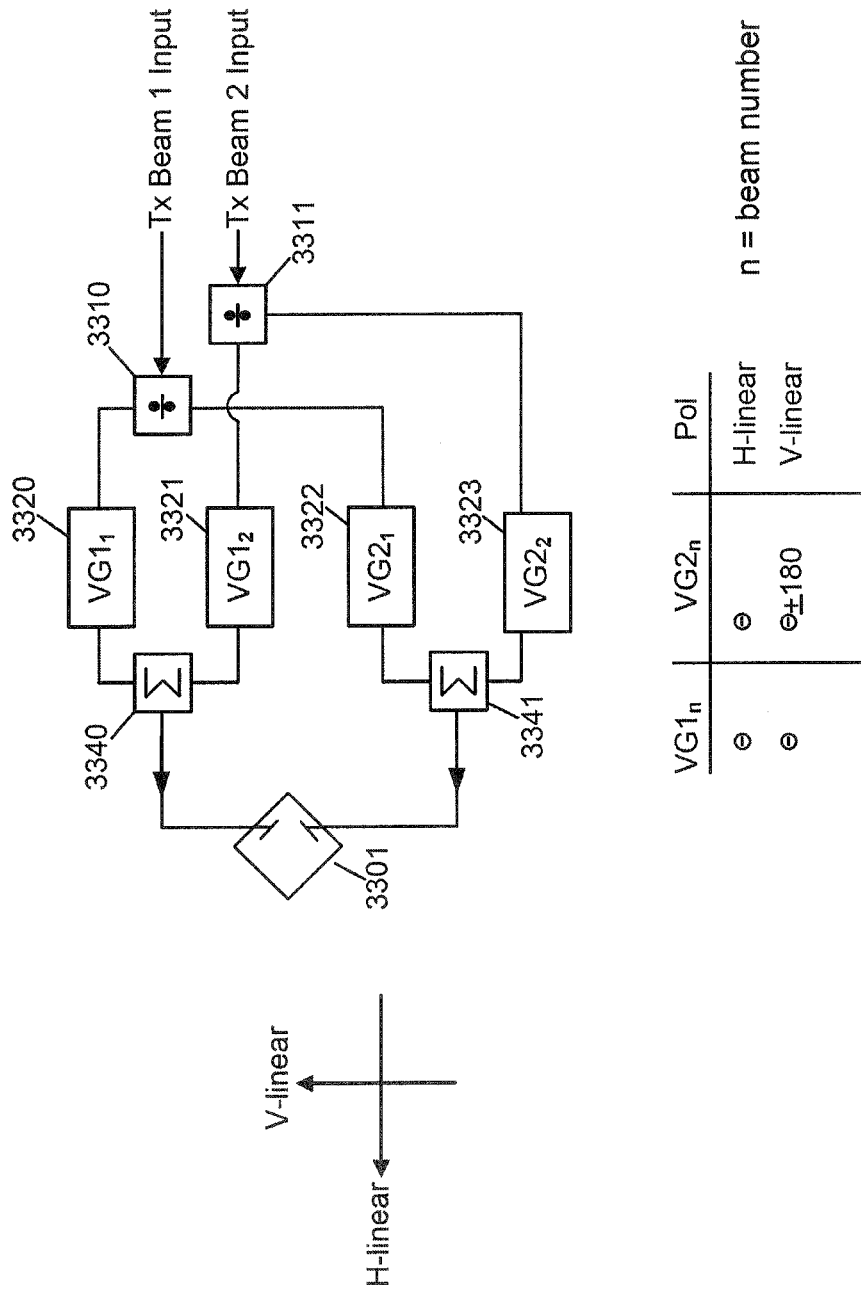
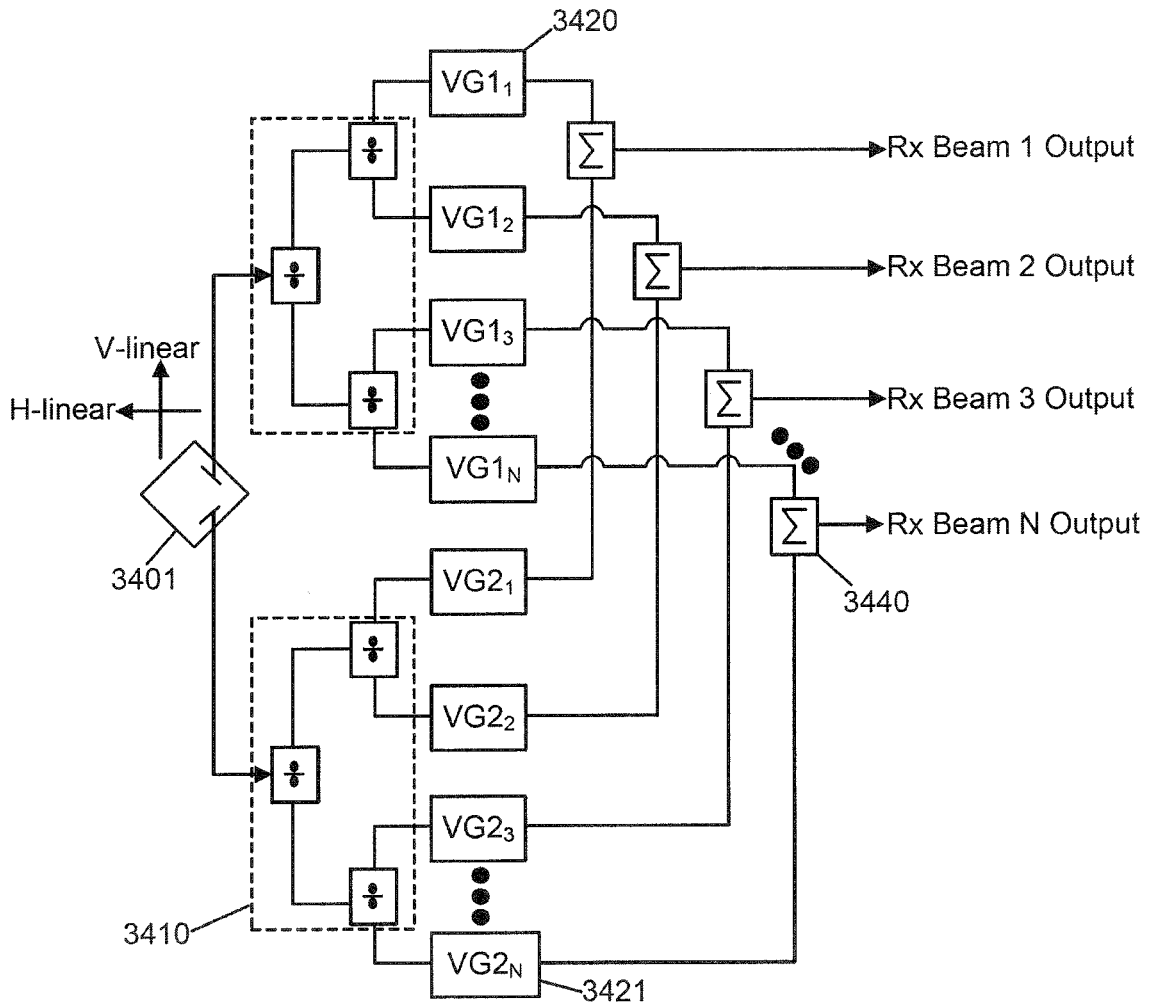

Fig. 33

3400



VG1 <sub>n</sub>	VG2 <sub>n</sub>	Pol
⊖	⊖	H-linear
⊖	⊖±180	V-linear

n = beam number

Fig. 34

3500

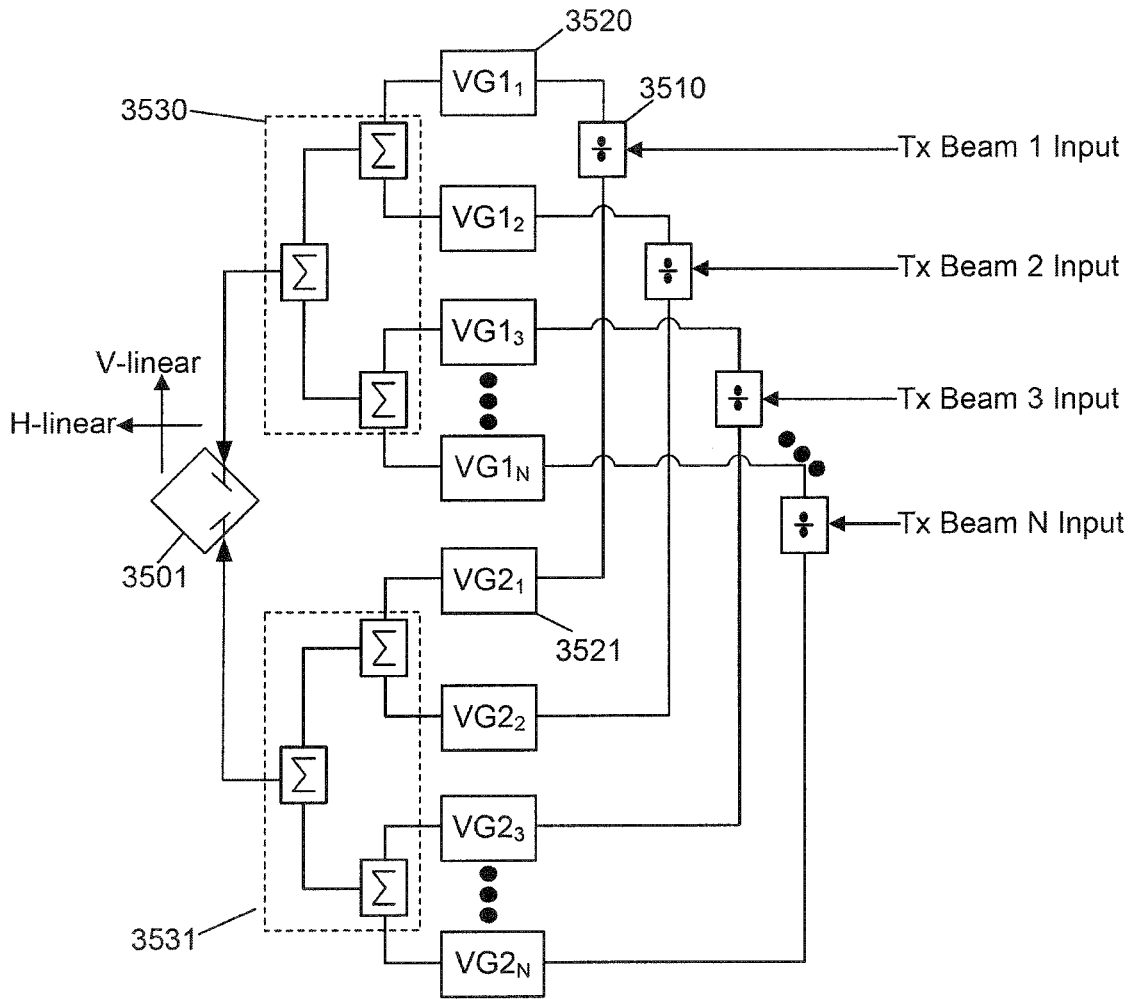

VG1 <sub>n</sub>	VG2 <sub>n</sub>	Pol
⊖	⊖	H-linear
⊖	⊖+180	V-linear

n = beam number

Fig. 35

3600

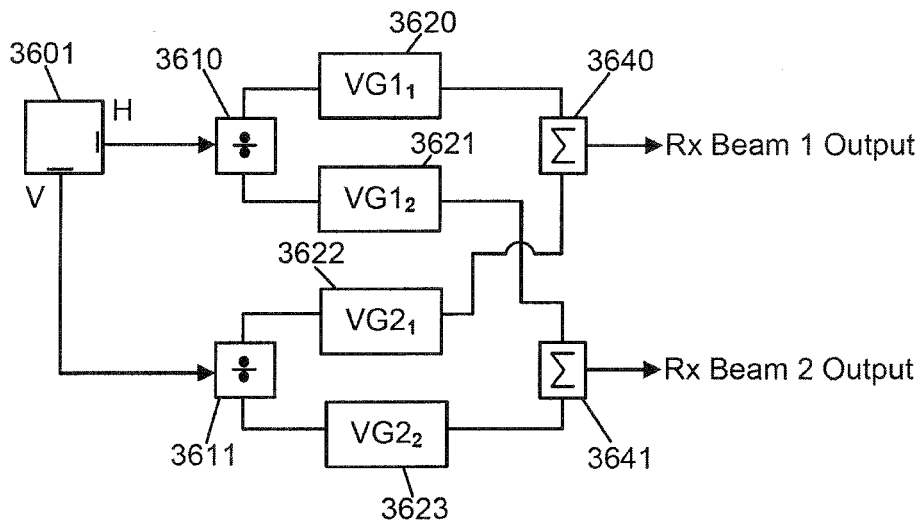

VG1 <sub>n</sub>	VG2 <sub>n</sub>	Pol
$\ominus$	$\ominus + 90^\circ$	RHCP
$\ominus$	$\ominus - 90^\circ$	LHCP
$\ominus$	$\ominus$	Slant Linear-H
$\ominus$	$\ominus \pm 180^\circ$	Slant Linear-V

n = beam number

Fig. 36

3700

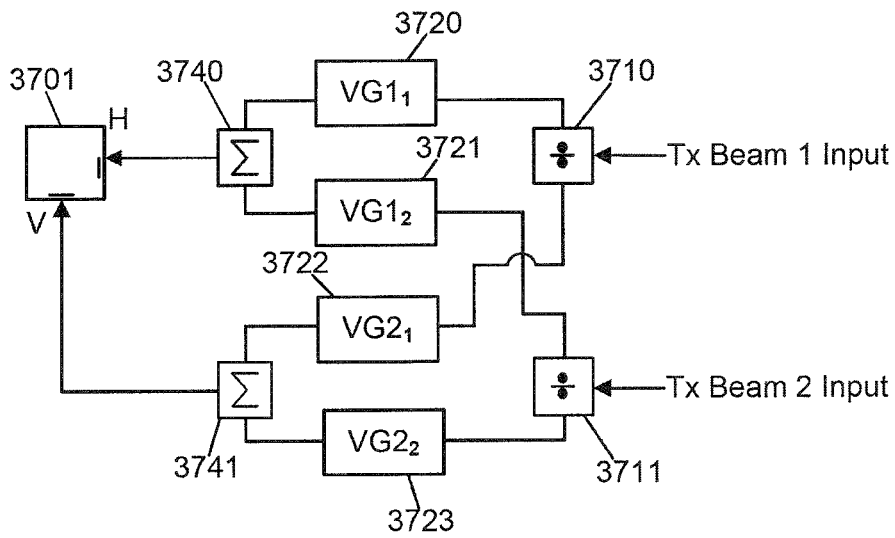

VG1 <sub>n</sub>	VG2 <sub>n</sub>	Pol
$\ominus$	$\ominus + 90^\circ$	RHCP
$\ominus$	$\ominus - 90^\circ$	LHCP
$\ominus$	$\ominus$	Slant Linear-H
$\ominus$	$\ominus \pm 180^\circ$	Slant Linear-V

n = beam number

Fig. 37

3800

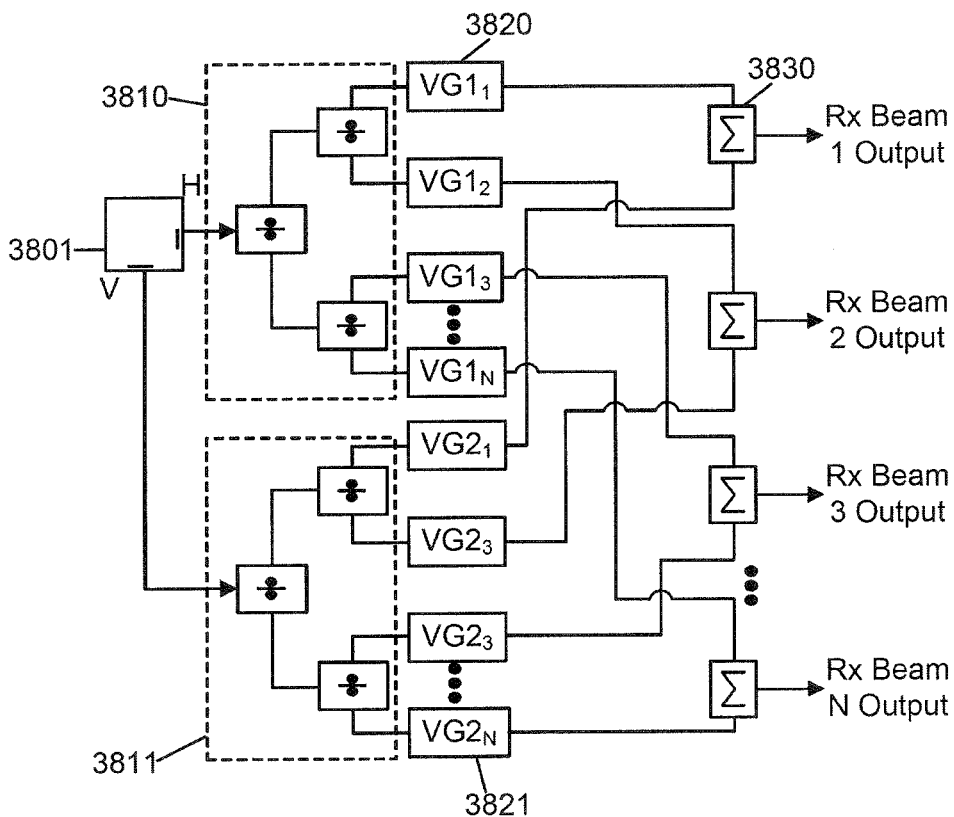

VG1 <sub>n</sub>	VG2 <sub>n</sub>	Pol
$\ominus$	$\ominus + 90^\circ$	RHCP
$\ominus$	$\ominus - 90^\circ$	LHCP
$\ominus$	$\ominus$	Slant Linear-H
$\ominus$	$\ominus \pm 180^\circ$	Slant Linear-V

n = beam number

Fig. 38

3900

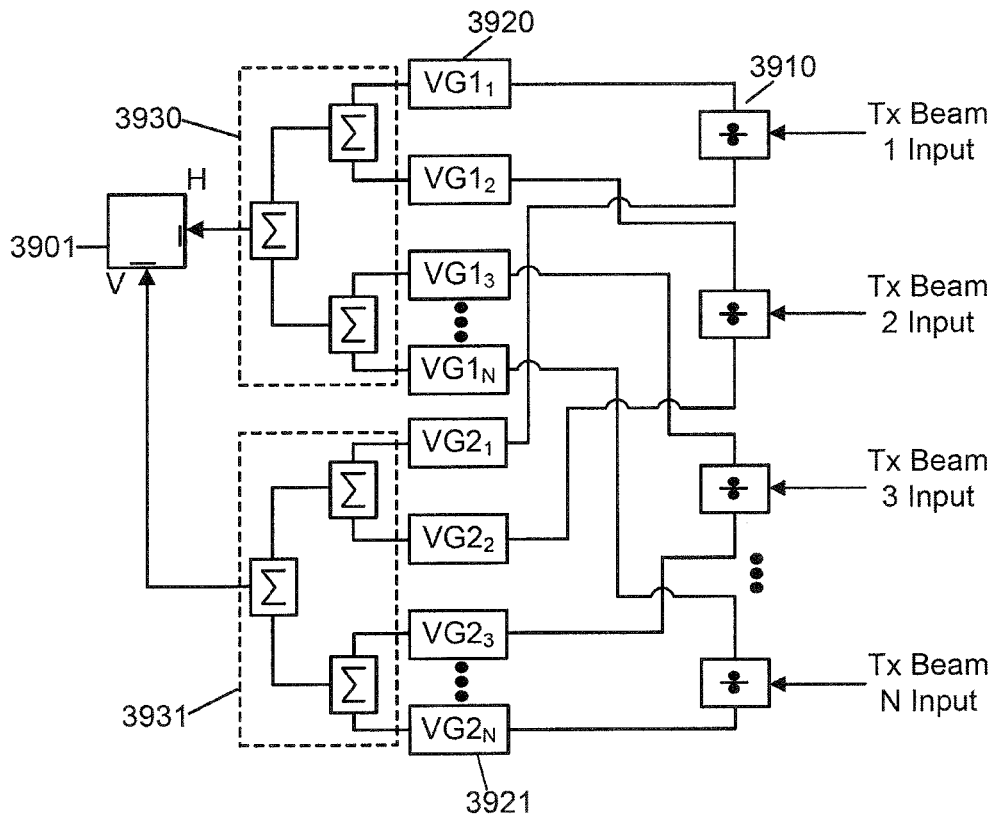

VG1 <sub>n</sub>	VG2 <sub>n</sub>	Pol
$\ominus$	$\ominus + 90^\circ$	RHCP
$\ominus$	$\ominus - 90^\circ$	LHCP
$\ominus$	$\ominus$	Slant Linear-H
$\ominus$	$\ominus \pm 180^\circ$	Slant Linear-V

n = beam number

Fig. 39



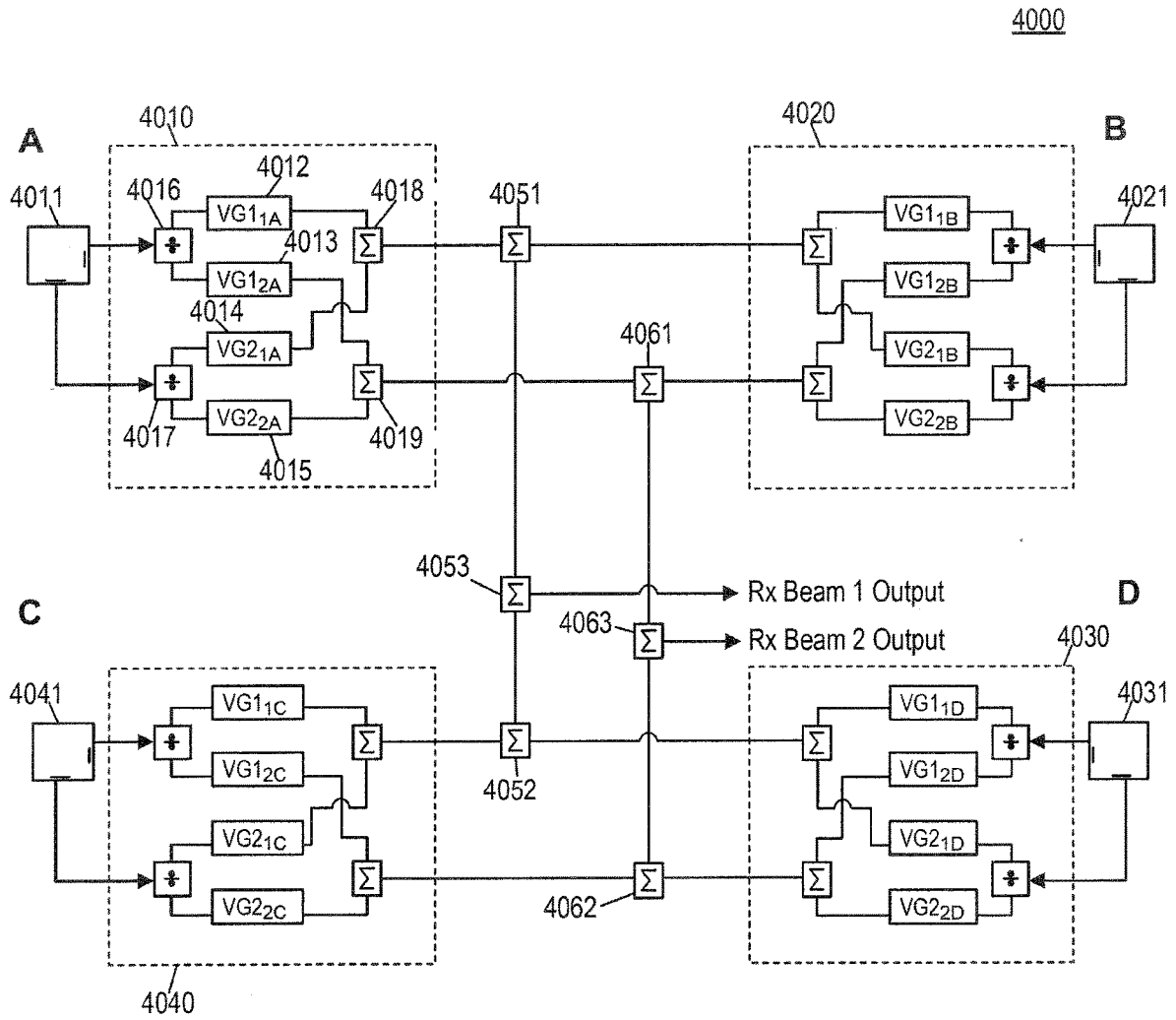

VG1 <sub>nj</sub>	VG2 <sub>nj</sub>	Pol
⊖	⊖ + 90°	RHCP
⊖	⊖ - 90°	LHCP
⊖	⊖	Slant Linear-H
⊖	⊖ ±180°	Slant Linear-V

n = beam number  
j = element number

Fig. 40

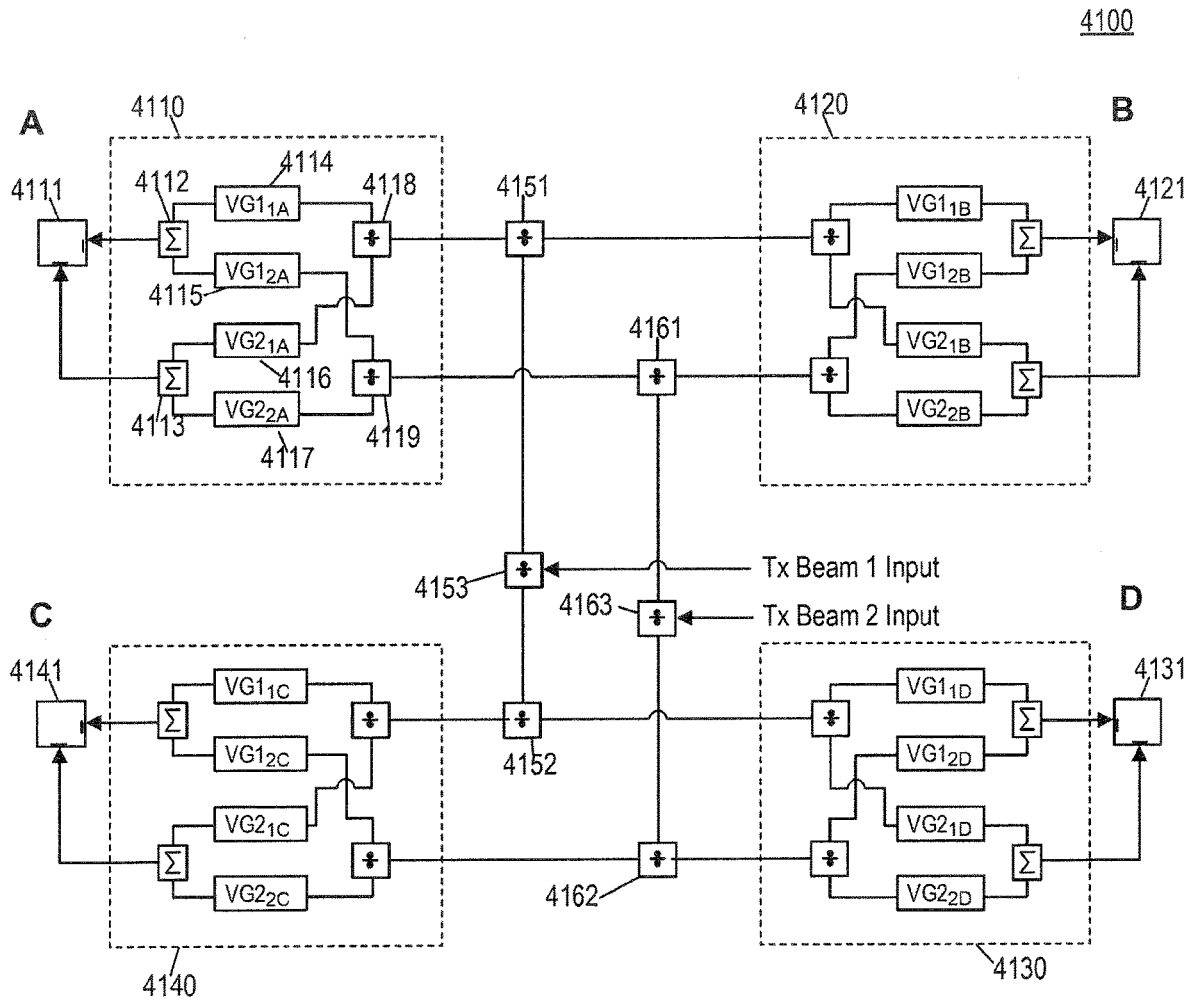

VG1 <sub>nj</sub>	VG2 <sub>nj</sub>	Pol
⊖	⊖ + 90°	RHCP
⊖	⊖ - 90°	LHCP
⊖	⊖	Slant Linear-H
⊖	⊖ ±180°	Slant Linear-V

n = beam number  
j = element number

Fig. 41

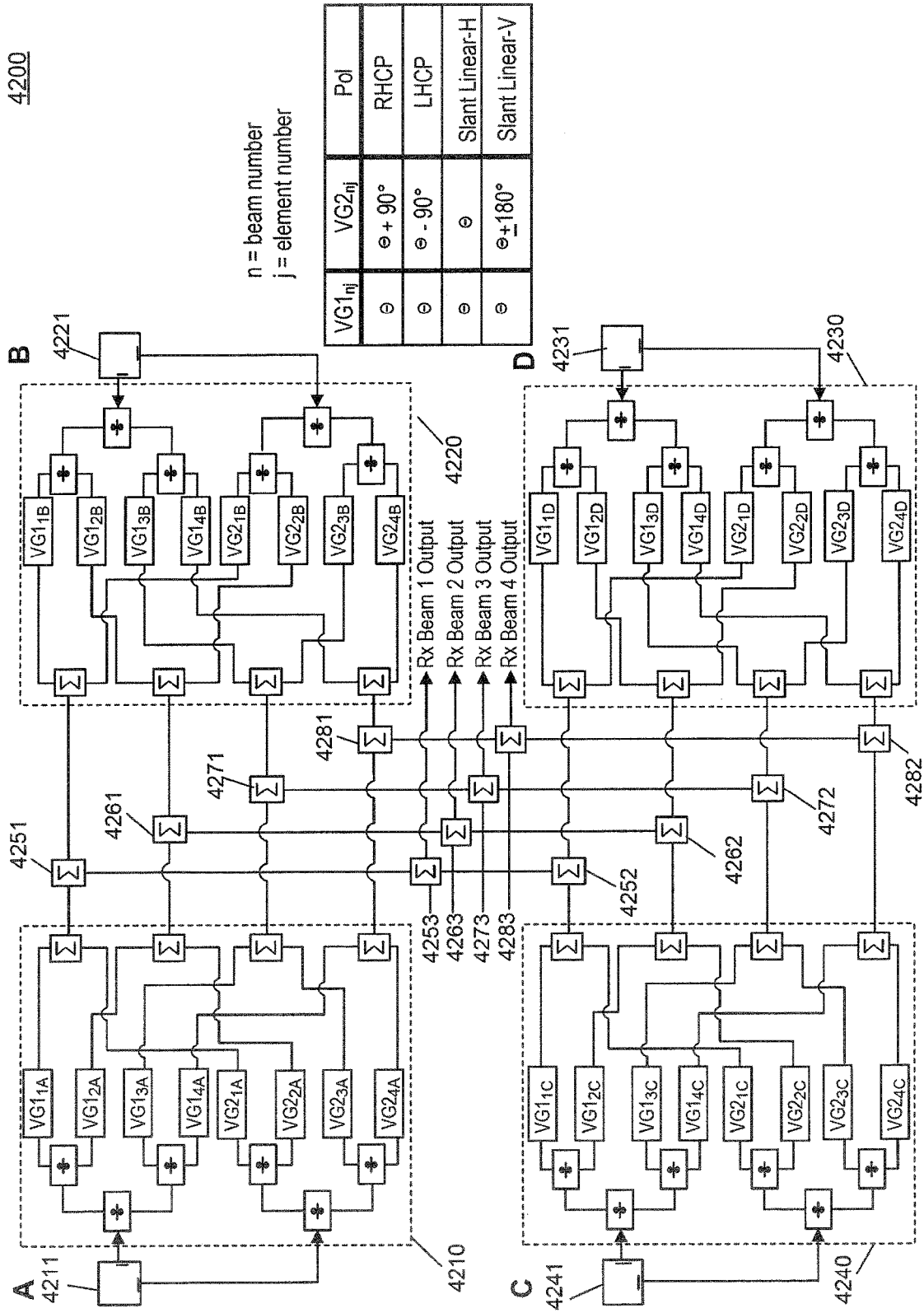

Fig. 42A

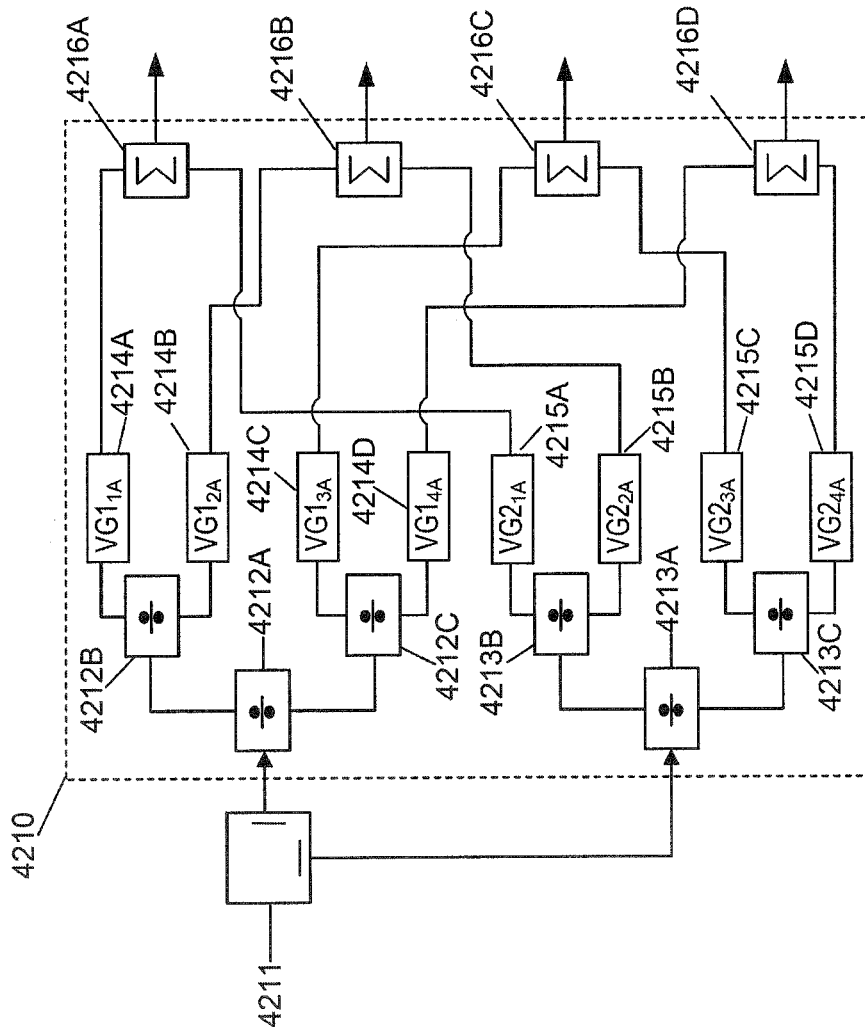

Fig. 42B

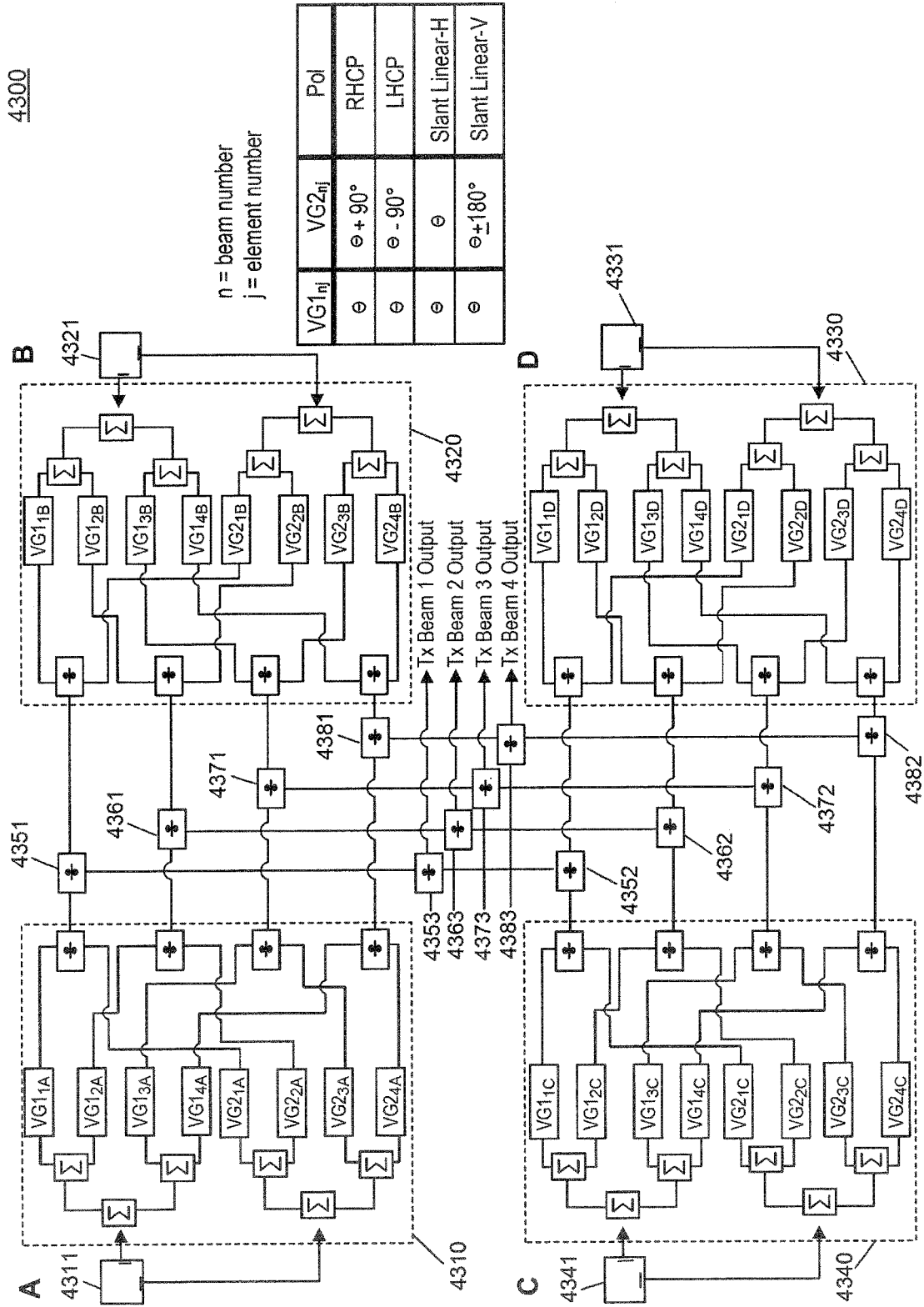

Fig. 43A

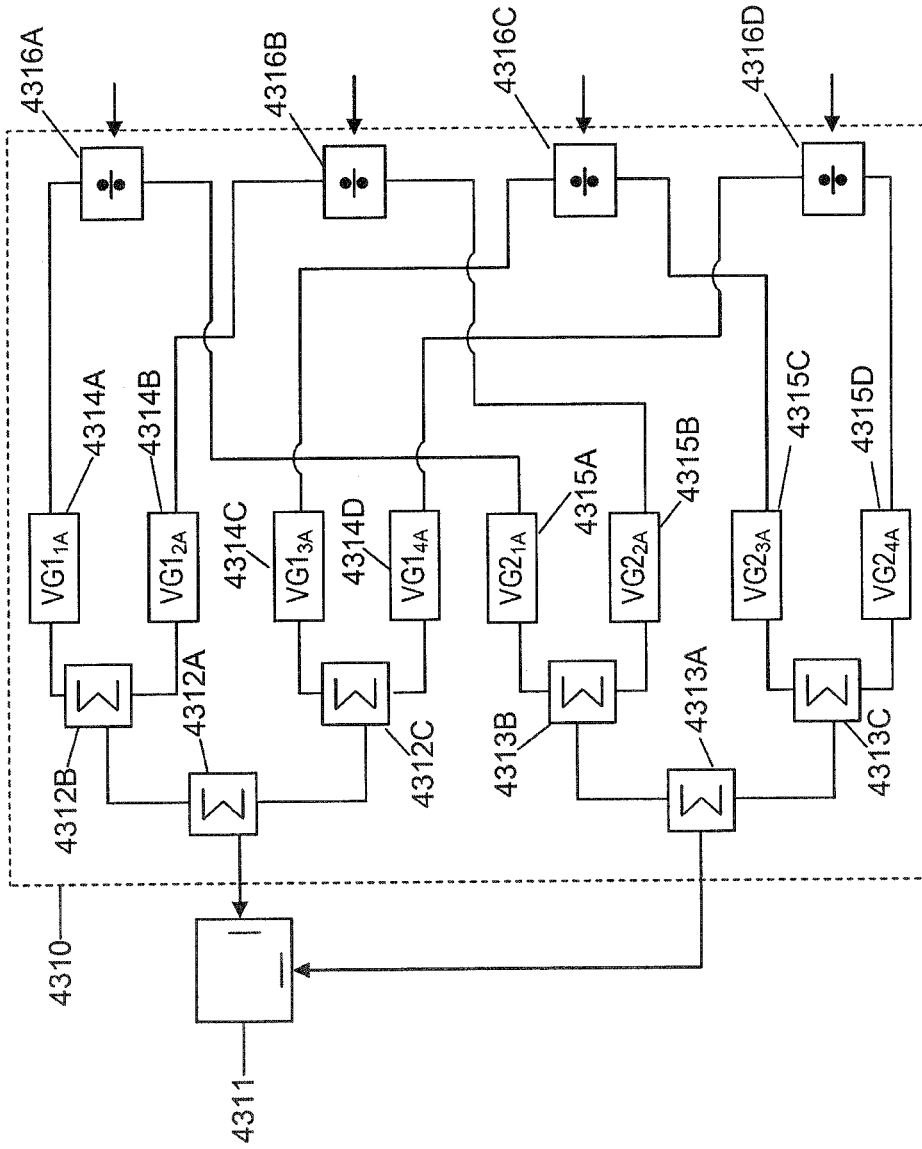

Fig. 43B

**MULTI-BEAM ACTIVE PHASED ARRAY  
ARCHITECTURE WITH INDEPENDENT  
POLARIZATION CONTROL**

CROSS REFERENCE TO RELATED  
APPLICATIONS

**[0001]** This application is a continuation of U.S. application Ser. No. 16/674,881, entitled “MULTI-BEAM ACTIVE PHASED ARRAY ARCHITECTURE WITH INDEPENDENT POLARIZATION CONTROL,” which was filed on Nov. 5, 2019. The ’881 application is a continuation of U.S. application Ser. No. 16/284,529, entitled “MULTI-BEAM ACTIVE PHASED ARRAY ARCHITECTURE WITH INDEPENDENT POLARIZATION CONTROL,” which was filed on Feb. 25, 2019, now U.S. Pat. No. 10,516,219 issued on Dec. 24, 2019. The ’529 application is a continuation of U.S. application Ser. No. 15/804,818, entitled “MULTI-BEAM ACTIVE PHASED ARRAY ARCHITECTURE WITH INDEPENDENT POLARIZATION CONTROL,” which was filed on Nov. 6, 2017, now U.S. Pat. No. 10,305,199 issued on May 28, 2019. The ’818 application is a continuation of U.S. application Ser. No. 15/212,111, entitled “MULTI-BEAM ACTIVE PHASED ARRAY ARCHITECTURE WITH INDEPENDENT POLARIZATION CONTROL,” which was filed on Jul. 15, 2016, now U.S. Pat. No. 9,843,107 issued on Dec. 12, 2017. The ’111 application is a continuation of U.S. application Ser. No. 14/617,630, entitled “MULTI-BEAM ACTIVE PHASED ARRAY ARCHITECTURE WITH INDEPENDENT POLARIZATION CONTROL,” which was filed on Feb. 9, 2015, now U.S. Pat. No. 9,425,890 issued on Aug. 23, 2016. The ’630 application is a continuation of U.S. application Ser. No. 14/216,760, entitled “MULTI-BEAM ACTIVE PHASED ARRAY ARCHITECTURE WITH INDEPENDENT POLARIZATION CONTROL,” which was filed on Mar. 17, 2014, now U.S. Pat. No. 8,995,943 issued on Mar. 31, 2015. The ’760 application is a continuation of U.S. application Ser. No. 13/692,683, entitled “MULTI-BEAM ACTIVE PHASED ARRAY ARCHITECTURE WITH INDEPENDENT POLARIZATION CONTROL,” which was filed on Dec. 3, 2012, now U.S. Pat. No. 8,693,970 issued on Apr. 8, 2014. The ’683 application is a continuation-in-part of U.S. application Ser. No. 13/412,901, entitled “MULTI-BEAM ACTIVE PHASED ARRAY ARCHITECTURE,” which was filed on Mar. 6, 2012, now U.S. Pat. No. 8,639,204 issued on Jan. 28, 2014. The ’901 application is a continuation application of U.S. application Ser. No. 12/759,059, entitled “MULTI-BEAM ACTIVE PHASED ARRAY ARCHITECTURE,” which was filed on Apr. 13, 2010, now U.S. Pat. No. 8,160,530 issued on Apr. 17, 2012, which is a non-provisional of U.S. Provisional Application No. 61/237,967, entitled “ACTIVE BUTLER AND BLASS MATRICES,” which was filed on Aug. 28, 2009. The ’059 application is also a non-provisional of U.S. Provisional Application No. 61/259,375, entitled “ACTIVE HYBRIDS FOR ANTENNA SYSTEMS,” which was filed on Nov. 9, 2009. The ’059 application is also a non-provisional of U.S. Provisional Application No. 61/234,513, entitled “ACTIVE FEED FORWARD AMPLIFIER,” which was filed on Aug. 17, 2009. The ’059 application is also a non-provisional of U.S. Provisional Application No. 61/222,354, entitled “ACTIVE PHASED ARRAY ARCHITECTURE,” which was filed on Jul. 1, 2009. The ’059 application is also a non-provisional of U.S. Provisional

Application No. 61/168,913, entitled “ACTIVE COMPONENT PHASED ARRAY ANTENNA,” which was filed on Apr. 13, 2009. The ’059 application is also a non-provisional of U.S. Provisional Application No. 61/259,049, entitled “DYNAMIC REAL-TIME POLARIZATION FOR ANTENNAS,” which was filed on Nov. 6, 2009. The ’059 application is also a non-provisional of U.S. Provisional Application No. 61/234,521, entitled “MULTI-BAND MULTI-BEAM PHASED ARRAY ARCHITECTURE,” which was filed on Aug. 17, 2009. The ’059 application is also a non-provisional of U.S. Provisional Application No. 61/265,605, entitled “HALF-DUPLEX PHASED ARRAY ANTENNA SYSTEM,” which was filed on Dec. 1, 2009. The ’059 application is also a non-provisional of U.S. Provisional Application No. 61/222,363, entitled “BIDIRECTIONAL ANTENNA POLARIZER,” which was filed on Jul. 1, 2009. All of the contents of the previously identified applications are hereby incorporated by reference for any purpose in their entirety.

BACKGROUND

**[0002]** A phased array antenna uses multiple radiating elements to transmit, receive, or transmit and receive radio frequency (RF) signals. Phased array antennas are used in various capacities, including communications on the move (COTM) antennas, satellite communication (SATCOM) airborne terminals, SATCOM mobile communications, and SATCOM earth terminals. The application of mobile terminals typically requires the use of automatic tracking antennas that are able to track the beam in azimuth, elevation, and polarization to follow the satellite position while the vehicle is in motion. Moreover, the antenna should be “low-profile,” small and lightweight, thereby fulfilling the stringent aerodynamic and mass constraints encountered in the typical mounting.

**[0003]** One well known type of phased array antenna is an electronically steerable phased array antenna. The electronically steerable phased array antenna has full electronic steering capability and is more compact and lower profile than a comparable mechanical phased array antenna. The main drawback of fully electronic steering is that the antenna usually requires the integration of a lot of expensive analog RF electronic components which may prohibitively raise the cost for commercial applications. A typical electronically steerable phased array antenna comprises an assembly of phase shifters, power splitters, power combiners, and quadrature hybrids. Additionally, a typical electronically steerable phased array requires at least a few of these components at every element in the phased array, which increases the cost and complexity of the architecture.

**[0004]** In a typical prior art embodiment and with reference to FIG. 1, a phased array antenna **100** comprises a radiating element **101** that communicates dual linear signals to a hybrid coupler **102** (either 90° or 180°) and then through low noise amplifiers **103**, **104**. Furthermore, the dual orthogonal signals are individually phase adjusted by phase shifters **105**, **106** before passing through a power combiner **107**. In addition, the typical components in a phased array antenna are distributed components that are frequency sensitive and designed for specific frequency bands.

**[0005]** Phase shifters are used in a phased array antenna in order to steer the beam of the signals by controlling the respective phases of the RF signals communicated through the phase shifters. A typical digital phase shifter uses

switched delay lines, is physically large, and operates over a narrow band of frequencies due to its distributed nature. Another typical digital phase shifter implements a switched high-pass low-pass filter architecture which has better operating bandwidth compared to a switched delay line but is still physically large.

**[0006]** Also, the phase shifter is often made on gallium arsenide (GaAs). Though other materials may be used, GaAs is a higher quality material designed and controlled to provide good performance of electronic devices. However, in addition to being a higher quality material than the other possible materials, GaAs is also more expensive and more difficult to manufacture. The typical phased array components take up a lot of area on the GaAs, and result in higher costs. Furthermore, a standard phase shifter has high RF loss, which is typically about  $n+1$  dB of loss, where  $n$  is the number of phase bits in the phase shifter. Another prior art embodiment uses RF MEMS switches and has lower loss but still consumes similar space and is generally incompatible with monolithic solutions.

**[0007]** Quadrature hybrids or other differential phase generating hybrids are used in a variety of RF applications. In an exemplary embodiment, quadrature hybrids are used for generating circular polarization signals, power combining, or power splitting. In an exemplary embodiment, the outputs of a quadrature hybrid have equal amplitude and a nominally  $90^\circ$  phase difference. In another typical embodiment, the quadrature hybrid is implemented as a distributed structure, such as a Lange coupler, a branchline coupler, and/or the like. A  $180^\circ$  hybrid, such as a magic tee or a ring hybrid, results in a nominally  $180^\circ$  phase shift. In general, quadrature hybrids and  $180^\circ$  hybrids are limited in frequency band and require significant physical space. Additionally, since the structures are distributed in nature, their physical size increases with decreasing frequency. Moreover, the quadrature hybrids and  $180^\circ$  hybrids are typically made of GaAs and have associated RF power loss on the order of 3-4 dB per hybrid when used as a power splitter, and an associated power loss of about 1 dB when used as a power combiner.

**[0008]** In-phase power combiners and in-phase power splitters are also used in a variety of RF applications. In an exemplary embodiment, the outputs of an in-phase hybrid have equal amplitude and a substantially zero differential phase difference. In another exemplary embodiment, the inputs of an in-phase hybrid configured as a power combiner encounter substantially zero differential phase and amplitude shift. In a prior art embodiment, the in-phase hybrid is implemented as a distributed structure such as a Wilkinson coupler. In general, an in-phase hybrid is limited in frequency band and requires significant physical space. Additionally, since the structure is distributed in nature, the physical size increases with decreasing frequency. The in-phase hybrid is typically made of GaAs. Moreover, the in-phase hybrid generally has associated RF power loss on the order of 3-4 dB per hybrid when used as a power splitter and an associated RF power loss of about 1 dB when used as a power combiner.

**[0009]** In addition to the different components in a phased array antenna, an antenna signal can have different polarizations, namely linear, elliptical, or circular. Linear polarization consists of vertical polarization and horizontal polarization, whereas circular polarization consists of left-hand circular polarization (LHCP) and right-hand circular polarization (RHCP). Elliptical polarization is similar to circular

polarization but occurs with different values for the vertical and horizontal component magnitudes or if the phase difference between the vertical and horizontal components is a value other than  $90^\circ$ .

**[0010]** Conventional antennas utilize a fixed polarization that is hardware dependent. The basis polarization is generally set during installation of the satellite terminal, at which point the manual configuration of the polarizer hardware is fixed. For example, a polarizer is generally set for LHCP or RHCP and fastened into position. To change polarization would require unfastening the polarizer, rotating it  $90^\circ$  to the opposite circular polarization, and then refastening the polarizer. Clearly this could not be done with much frequency and only a limited number (on the order of 10 or may be 20) of transceivers could be switched per technician in a given day.

**[0011]** Unlike a typical prior art single polarization antenna, some devices are configured to change polarizations without disassembling the antenna terminal. As an example and with reference to FIG. 2, a prior embodiment is the use of "baseball" switches to provide electronically commandable switching between polarizations. As can be understood by the block diagram, the rotation of the "baseball" switches causes a change in polarization by connecting one signal path to a waveguide while terminating the other signal path. However, each "baseball" switch is physically large and requires a separate rotational actuator with independent control circuitry, which increases the cost of the device such that this configuration is typically not used in consumer broadband terminals.

**[0012]** Furthermore, another approach is to have a system with duplicate transmit and receive hardware for each polarization. The polarization selection is achieved by maintaining the path of the desired signal and deselecting the undesired signal. However, doubling the hardware greatly increases the cost of the terminal. In yet another embodiment, a system may implement solid state diode or FET-based switches. The use of these electronic components may lead to high loss and limited power handling in microwave and mm-wave applications. These alternatives are size, power, and cost prohibitive for most applications, including phased arrays and low cost commercial applications.

**[0013]** Additionally, typical phased array antennas only form a single beam at a time and are often not capable of switching polarization. In order to form additional beams and/or have polarization switching ability from the same radiating aperture, additional phase shifting and power splitting or combining components are required at every radiating element. These additional components are typically distributed in nature, require significant physical space, are lossy, and only operate over relatively narrow frequency bands. For these reasons, polarization agile, multiple beam phased array antennas that can operate over multiple frequency bands are difficult to realize in practice.

**[0014]** Thus, a need exists for a phased array antenna architecture that is not frequency limited or polarization specific, and that is reconfigurable for different polarizations and able to transmit and/or receive over multiple frequencies and form multiple beams. Furthermore, the antenna architecture should be able to be manufactured on a variety of materials and with no associated RF loss. Also, a need exists for a phased array antenna that uses less space than a similar capability prior art architecture, is suitable for a monolithic



implementation, and has components with a physical size that is independent of operating frequency.

#### SUMMARY

**[0015]** An active phased array architecture may replace traditional distributed and GaAs implementations for the necessary functions required to operate electronically steerable phased array antennas. The architecture combines active versions of vector generators, power splitters, power combiners, and/or RF hybrids in a novel fashion to realize a fully or substantially monolithic solution for a wide range of antenna applications that can be realized with radiating elements having dual-polarized feeds.

**[0016]** Overall, an active antenna polarizer is a digitally controlled active implementation for processing an RF signal. In accordance with an exemplary receive embodiment, the polarization and amplitude of the RF signal communicated through a phased array radiating element is adjustable by operating multiple vector generators in parallel and feeding one or both output signals of the multiple vector generators to the radiating element in spatially orthogonal fashion. In various embodiments, two output beams can have independent polarization and beam steering. The phased array antenna is configured to electrically change between polarizations and/or support beam steering. For example, the phased array antenna may alternate between linear polarization, elliptical polarization, and circular polarization. In accordance with an exemplary embodiment, in order to operate in these different polarizations, vector generators control the relative phase of the antenna signal. In an exemplary embodiment, the basic transmit embodiment and receive embodiment are used in any frequency band and with different polarizations.

**[0017]** In an exemplary embodiment, a phased array antenna comprises multiple subcircuits in communication with multiple radiating elements. The radio frequency signals are adjusted for both polarization control and beam steering. In a receive embodiment, multiple RF signals are received and combined into at least one receive beam output. In a transmit embodiment, at least one transmit beam input is divided and transmitted through multiple radiating elements.

**[0018]** In an exemplary embodiment, the phased array antenna provides multi-beam formation over multiple operating frequency bands. The phased array antenna replaces traditional distributed components and GaAs functions with active components to operate an electronically steerable multiple beam phased array antenna. The wideband nature of the active components allows for operation over multiple frequency bands simultaneously. Furthermore, the antenna polarization may be static or dynamically controlled at the subarray or radiating element level.

**[0019]** Advantages of the exemplary phased array antenna include increased system capacity and flexibility. Furthermore, an antenna that can operate over multiple frequency bands optimizes system availability. This system may be implemented in mobile applications, or fixed position applications where multiple systems are desired. Also, a single antenna can communicate with multiple systems and/or users, allowing for increased capacity and availability.

#### BRIEF DESCRIPTION OF THE DRAWING FIGURES

**[0020]** A more complete understanding of the present invention may be derived by referring to the detailed

description and claims when considered in connection with the drawing figures, wherein like reference numbers refer to similar elements throughout the drawing figures, and:

**[0021]** FIG. 1 illustrates a prior art example of a phased array antenna element and control electronics;

**[0022]** FIG. 2 illustrates a prior art example of an antenna with polarization switching;

**[0023]** FIG. 3 illustrates an example embodiment of an active power splitter;

**[0024]** FIG. 4 illustrates an example embodiment of an active power combiner;

**[0025]** FIG. 5 illustrates an example embodiment of an active vector generator;

**[0026]** FIG. 6 illustrates an example embodiment of an active RF hybrid;

**[0027]** FIG. 7 illustrates an example embodiment of an active antenna signal polarizer;

**[0028]** FIG. 8 illustrates an example embodiment of a phased array antenna with horizontal linear polarization for transmit mode;

**[0029]** FIG. 9 illustrates an example embodiment of a phased array antenna with dual linear polarization for transmit mode;

**[0030]** FIG. 10 illustrates an example embodiment of a phased array antenna with horizontal linear polarization for receive mode;

**[0031]** FIG. 11 illustrates an example embodiment of a phased array antenna with dual linear polarization for receive mode;

**[0032]** FIG. 12 illustrates an example embodiment of a phased array antenna with differentially fed horizontal linear polarization for transmit mode;

**[0033]** FIG. 13 illustrates an example embodiment of a phased array antenna with differentially fed dual linear polarization for transmit mode;

**[0034]** FIG. 14 illustrates an example embodiment of a phased array antenna with differentially fed horizontal linear polarization for receive mode;

**[0035]** FIG. 15 illustrates an example embodiment of a phased array antenna with differentially fed dual linear polarization for receive mode;

**[0036]** FIG. 16 illustrates an example embodiment of a phased array integrated circuit configured as a 1-beam, 4-element transmitter;

**[0037]** FIG. 17 illustrates an example embodiment of a phased array integrated circuit configured as a 1-beam, 4-element receiver;

**[0038]** FIG. 18 illustrates an example embodiment of a phased array integrated circuit configured as a 2-beam, 4-element receiver;

**[0039]** FIG. 19 illustrates an example embodiment of a phased array integrated circuit configured as a 2-beam, 4-element transmitter;

**[0040]** FIG. 20 illustrates an example embodiment of a phased array integrated circuit configured as a 4-beam, 4-element receiver;

**[0041]** FIG. 21 illustrates an example embodiment of a phased array integrated circuit configured as a 4-beam, 4-element transmitter;

**[0042]** FIG. 22 illustrates another example embodiment of a phased array integrated circuit configured as a 2-beam, 4-element receiver;

**[0043]** FIG. 23 illustrates an example embodiment of a multi-beam architecture;

[0044] FIG. 24 illustrates an example embodiment of a dual-polarization multi-beam receive architecture;

[0045] FIG. 25 illustrates another example embodiment of a dual-polarization multi-beam receive architecture;

[0046] FIG. 26 illustrates an example embodiment of a dual-polarization multi-beam transmit architecture;

[0047] FIG. 27 illustrates another example embodiment of a dual-polarization multi-beam transmit architecture;

[0048] FIG. 28 illustrates an example embodiment of color distribution;

[0049] FIGS. 29A-29C illustrate various satellite spot beam multicolor agility methods in accordance with example embodiments;

[0050] FIG. 30 illustrates an example embodiment of a phased array antenna with slant polarization for receive mode;

[0051] FIG. 31 illustrates an example embodiment of a phased array antenna with slant polarization for transmit mode;

[0052] FIG. 32 illustrates an example embodiment of a phased array antenna with dual-beam slant polarization for receive mode;

[0053] FIG. 33 illustrates an example embodiment of a phased array antenna with dual-beam slant polarization for transmit mode;

[0054] FIG. 34 illustrates an example embodiment of a phased array integrated circuit configured as a 4-beam, 1-element receiver;

[0055] FIG. 35 illustrates an example embodiment of a phased array integrated circuit configured as a 4-beam, 1-element transmitter;

[0056] FIG. 36 illustrates an example embodiment of a phased array integrated circuit configured as a 2-beam, 1-element receiver with independent polarization;

[0057] FIG. 37 illustrates an example embodiment of a phased array integrated circuit configured as a 2-beam, 1-element transmitter with independent polarization;

[0058] FIG. 38 illustrates an example embodiment of a phased array integrated circuit configured as a 4-beam, 1-element receiver with independent polarization;

[0059] FIG. 39 illustrates an example embodiment of a phased array integrated circuit configured as a 4-beam, 1-element transmitter with independent polarization;

[0060] FIG. 40 illustrates an example embodiment of a phased array integrated circuit configured as a 2-beam, 4-element receiver with independent polarization;

[0061] FIG. 41 illustrates an example embodiment of a phased array integrated circuit configured as a 2-beam, 4-element transmitter with independent polarization;

[0062] FIGS. 42A-42B illustrate an example embodiment of a phased array integrated circuit configured as a 4-beam, 4-element receiver with independent polarization; and

[0063] FIGS. 43A-43B illustrate an example embodiment of a phased array integrated circuit configured as a 4-beam, 4-element transmitter with independent polarization.

#### DETAILED DESCRIPTION OF THE INVENTION

[0064] While exemplary embodiments are described herein in sufficient detail to enable those skilled in the art to practice the invention, it should be understood that other embodiments may be realized and that logical, electrical, and mechanical changes may be made without

departing from the spirit and scope of the invention. Thus, the following detailed description is presented for purposes of illustration only.

[0065] An electronically steerable phased array antenna may be used in various scenarios. For example, the phased array antenna may be implemented in COTM antennas, SATCOM airborne terminals, SATCOM mobile communications, and SATCOM earth terminals. In an exemplary embodiment, a phased array antenna comprises a layout of various active component building blocks, such as baluns, power splitters, power combiners, hybrids, and vector generators. Although throughout the application reference may be made to “active power splitters, vector generators, and active power combiners” in various exemplary embodiments, only one or more of those devices may be used in various embodiments, as opposed to all three devices.

[0066] A phased array antenna generally comprises multiple radiating elements, with each radiating element having a polarization component. In an exemplary embodiment, the radiating element has spatially orthogonal linear polarizations, spatially and electrically orthogonal circular polarizations, or spatially orthogonal and electrically non-orthogonal elliptical polarizations. In an exemplary embodiment, a phased array antenna comprises various components. The various components may include a vector generator, an active power splitter, an active power combiner, or the like. Furthermore, in an exemplary embodiment, the phased array antenna comprises a patch antenna. Though a patch antenna is illustrated in the figures and described herein, other types of radiating elements may be implemented. Such radiating elements include a fragmented radiator, a feed horn antenna, a slot antenna, and the like.

[0067] In an exemplary embodiment, each radiating element has two feed ports and results in an unbalanced feed system. In yet another exemplary embodiment, each radiating element has three feed ports and results in a partially balanced feed system. In another exemplary embodiment, each radiating element has four feed ports and results in a fully balanced feed system.

[0068] In an exemplary embodiment, a phased array antenna with two feed ports is configured to generate and control different polarizations. Exemplary polarization states include a single circular polarization state, a single elliptical polarization state, a single linear polarization state, and two orthogonal linear polarization states.

[0069] The radiating elements may be in communication with an RF integrated circuit (RFIC). In an exemplary embodiment, the RFIC is configured to divide, alter, and re-combine the basis polarizations to other orthogonal polarization states. The RF signal corresponding to the net polarization state in the RFIC may additionally be combined in a beam-forming network of the array.

[0070] Active Splitter:

[0071] FIG. 3 illustrates a schematic of an exemplary active power splitter. In an exemplary embodiment, an active power splitter 300 comprises a differential input subcircuit 310, a first differential output subcircuit 320, and a second differential output subcircuit 330. The differential input subcircuit 310 has paired transistors 311, 312 with a common emitter node and is constant current biased, as is typical in a differential amplifier. An input signal is communicated to the base of paired transistors 311, 312 in the differential input subcircuit 310. Both the first and second

differential output subcircuits **320**, **330** comprise a pair of transistors with a common base node and each common base is connected to ground.

[0072] The first differential output subcircuit **320** has a first transistor **321** emitter connected to the collector of one of the input subcircuit transistors **312**. The emitter of the second output subcircuit transistor **322** is connected to the collector of the other input subcircuit transistor **311**. In the exemplary embodiment, the first output is drawn from the collectors of transistors **321**, **322** of the first differential output subcircuit **320**. Furthermore, the second differential output subcircuit **330** is similarly connected, except the transistor **331**, **332** emitters are inversely connected to the input subcircuit transistor **311**, **312** collectors with respect to transistors **321**, **322**.

[0073] By inverting the input subcircuit transistor collector connections between the first and second differential output subcircuits, the first output and the second output are approximately 180° out of phase with each other. In another exemplary embodiment, transistor **331**, **332** emitters are non-inversely connected to input subcircuit transistor **311**, **312** collectors, causing the first output and the second output to be approximately in phase with each other. In general, the absolute phase shift of the output signals through the power splitter is not as important as the relative phasing between the first and second output signals.

[0074] In an exemplary embodiment, active power splitter **300** converts an input RF signal into two output signals. The output signal levels may be equal in amplitude, though this is not required. For a prior art passive power splitter, each output signal would be about 3 dB lower in power than the input signal. In contrast, an exemplary active splitter, such as active power splitter **300**, can provide gain and the relative power level between the input signal and output signal is adjustable and can be selectively designed. In an exemplary embodiment, the output signal is configured to achieve a substantially neutral or positive power gain over the input signal. For example, the output signal may achieve a 3 dB signal power gain over the input signal. In an exemplary embodiment, the output signal may achieve a power gain in the 0 dB to 5 dB range. Moreover, the output signal may be configured to achieve any suitable power gain.

[0075] In accordance with an exemplary embodiment, active power splitter **300** produces output signals with a differential phase between the two signals that is zero or substantially zero. The absolute phase shift of output signals through the active power splitter may not be as important as the differential phasing between the output signals.

[0076] In another exemplary embodiment, active power splitter **300** additionally provides matched impedances at the input and output ports. The matched impedances may be 50 ohms, 75 ohms, or other suitable impedances. Furthermore, in an exemplary embodiment, active power splitter **300** provides isolation between the output ports of the active power splitter. In one exemplary embodiment, active power splitter **300** is manufactured as a radio frequency integrated circuit (RFIC) with a compact size that is independent of the operating frequency due to a lack of distributed components.

[0077] Active Combiner:

[0078] In an exemplary embodiment and with reference to FIG. 4, an active power combiner **400** comprises a first differential input subcircuit **410**, a second differential input subcircuit **420**, a single ended output subcircuit **430**, and a differential output subcircuit **440**. Each differential input

subcircuit **410**, **420** includes two pairs of transistors, with each transistor of each differential input subcircuit **410**, **420** having a common emitter node with constant current biasing, as is typical in a differential amplifier.

[0079] A first input signal is communicated to the bases of the transistors in first differential input subcircuit **410**. For example, a first line of input signal In1 is provided to one transistor of each transistor pair in first differential input subcircuit **410**, and a second line of input signal In1 is provided to the other transistor of each transistor pair. Similarly, a second input signal is communicated to the bases of the transistors in second differential input subcircuit **420**. For example, a first line of input signal In2 is provided to one transistor of each transistor pair in first differential input subcircuit **420**, and a second line of input signal In2 is provided to the other transistor of each transistor pair. Furthermore, in an exemplary embodiment, a differential output signal is formed by a combination of signals from collectors of transistors in first and second differential input subcircuits **410**, **420**.

[0080] In an exemplary embodiment, active power combiner **400** converts two input RF signals into a single output signal. The output signal can either be a single ended output at single ended output subcircuit **430**, or a differential output at differential output subcircuit **440**. In other words, active power combiner **400** performs a function that is the inverse of active power splitter **300**. The input signal levels can be of arbitrary amplitude and phase. Similar to an active power splitter, active power combiner **400** can provide gain and the relative power level between the inputs and output is also adjustable and can be selectively designed. In an exemplary embodiment, the output signal achieves a substantially neutral or positive signal power gain over the input signal. For example, the output signal may achieve a 3 dB power gain over the sum of the input signals. In an exemplary embodiment, the output signal may achieve a power gain in the 0 dB to 5 dB range. Moreover, the output signal may achieve any suitable power gain.

[0081] In an exemplary embodiment, active power combiner **400** additionally provides matched impedances at the input and output ports. The matched impedances may be 50 ohms, 75 ohms, or other suitable impedances. Furthermore, in an exemplary embodiment, active power combiner **400** provides isolation between the input ports of the power combiner. In one exemplary embodiment, active power combiner **400** is manufactured as a RFIC with a compact size that is independent of the operating frequency due to a lack of distributed components.

[0082] Vector Generator:

[0083] In an exemplary embodiment, a vector generator converts an RF input signal into an output signal (sometimes referred to as an output vector) that is shifted in phase and/or amplitude to a desired level. This replaces the function of a typical phase shifter and adds the capability of amplitude control. In other words, a vector generator is a magnitude and phase control circuit. In the exemplary embodiment, the vector generator accomplishes this function by feeding the RF input signal into a quadrature network resulting in two output signals that differ in phase by about 90°. The two output signals are fed into parallel quadrant select circuits, and then through parallel variable gain amplifiers (VGAs). In an exemplary embodiment, the quadrant select circuits receive commands and may be configured to either pass the output signals with no additional relative phase shift

between them or invert either or both of the output signals by an additional 180°. In this fashion, all four possible quadrants of the 360° continuum are available to both orthogonal signals. The resulting composite output signals from the current summer are modulated in at least one of amplitude and phase.

**[0084]** In accordance with an exemplary embodiment and with reference to FIG. 5, a vector generator 500 comprises a passive I/Q generator 510, a first VGA 520 and a second VGA 521, a first quadrant select 530 and a second quadrant select 531 each configured for phase inversion switching, and a current summer 540. The first quadrant select 530 is in communication with I/Q generator 510 and first VGA 520. The second quadrant select 531 is in communication with I/Q generator 510 and second VGA 521. Furthermore, in an exemplary embodiment, vector generator 500 comprises a digital controller 550 that controls a first digital-to-analog converter (DAC) 560 and a second DAC 561. The first and second DACs 560, 561 control first and second VGAs 521, 520, respectively. Additionally, digital controller 550 controls first and second quadrant selects 530, 531.

**[0085]** In an exemplary embodiment, vector generator 500 controls the phase and amplitude of an RF signal by splitting the RF signal into two separate vectors, the in-phase (I) vector and the quadrature-phase (Q) vector. In one embodiment, the RF signal is communicated differentially. The differential RF signal communication may be throughout vector generator 500 or limited to various portions of vector generator 500. In another exemplary embodiment, the RF signals are communicated non-differentially. The I vector and Q vector are processed in parallel, each passing through the phase inverting switching performed by first and second quadrant selects 530, 531. The resultant outputs of the phase inverting switches comprise four possible signals: a non-inverted I, an inverted I, a non-inverted Q, and an inverted Q. In this manner, all four quadrants of a phasor diagram are available for further processing by VGAs 520, 521. In an exemplary embodiment, two of the four possible signals non-inverted I, inverted I, non-inverted Q, and inverted Q are processed respectively through VGAs 520, 521, until the two selected signals are combined in current summer 540 to form a composite RF signal. The current summer 540 outputs the composite RF signal with phase and amplitude adjustments. In an exemplary embodiment, the composite RF signal is in differential signal form. In another exemplary embodiment, the composite RF signals are in single-ended form.

**[0086]** In an exemplary embodiment, control for the quadrant shifting and VGA functions is provided by a pair of DACs. In an exemplary embodiment, reconfiguration of digital controller 550 allows the number of phase bits to be digitally controlled after vector generator 500 is fabricated if adequate DAC resolution and automatic gain control (AGC) dynamic range exists. In an exemplary embodiment with adequate DAC resolution and AGC dynamic range, any desired vector phase and amplitude can be produced with selectable fine quantization steps using digital control. In another exemplary embodiment, reconfiguration of DACs 560, 561 can be made after vector generator 500 is fabricated in order to facilitate adjustment of the vector amplitudes.

**[0087]** Active RF Hybrid:

**[0088]** In an exemplary embodiment, and with reference to FIG. 6, an active RF hybrid 600 comprises a first active

power splitter 610, a second active power splitter 611, a first vector generator 620, a second vector generator 621, a first active power combiner 630, a second active power combiner 631, a first digital-to-analog converter (DAC) 640 and a second DAC 641. In accordance with the exemplary embodiment, first active power splitter 610 receives an input at Port 1 and communicates the input to first vector generator 620 and second active power combiner 631. Likewise, second active power splitter 611 receives an input at Port 2 and communicates the input to second vector generator 621 and first active power combiner 630. Vector generators 620, 621 are controlled in part by respective DACs 640, 641. In an exemplary embodiment, a 4-bit DAC is used but any number of bits many be used.

**[0089]** Furthermore, the output of first vector generator 620 is communicated to first active power combiner 630, and the output of second vector generator 621 is communicated to second active power combiner 631. In the exemplary embodiment, first active power combiner 630 receives input from first vector generator 620 and second active power splitter 611, and outputs a signal to Port 3. Similarly, second active power combiner 631 receives input from second vector generator 621 and first active power splitter 610, and outputs a signal to Port 4.

**[0090]** Active RF hybrid 600 may be used to replace various distributed components, such as a branchline coupler, Lange coupler, directional coupler, or 180° hybrid. In accordance with an exemplary embodiment, an active RF hybrid provides similar functionality in comparison to a traditional distributed hybrid. For example, active RF hybrid 600 may be dynamically configured to have variable phase differences between the output ports, which could be 90°, 180°, or some other phase difference. Another example is that active RF hybrid 600 provides port-to-port isolation and matched impedances at the input/output ports. Additional information regarding active RF hybrids is disclosed in the U.S. patent application Ser. No. 12/759,043, entitled "ACTIVE HYBRIDS FOR ANTENNA SYSTEMS," filed Apr. 13, 2010, which is hereby incorporated by reference.

**[0091]** Furthermore, the active RF hybrid 600 has various advantages over a traditional passive distributed hybrid. In an exemplary embodiment, the active RF hybrid 600 does not result in a loss of power, but instead has a gain or is at least gain neutral. In another exemplary embodiment, the active RF hybrid 600 does not rely on distributed elements and is capable of operating over very wide bandwidths. In yet another exemplary embodiment, the active RF hybrid 600 implements identical building block components as used in an exemplary active phased array architecture. In one exemplary embodiment, the active RF hybrid 600 is manufactured as a monolithic microwave integrated circuit (MIMIC) with a compact size that is independent of the operating frequency due to a lack of distributed components.

**[0092]** The components described above may be implemented in various phased array antenna embodiments. The various phased array antenna embodiments include variations on transmit or receive embodiments, number of beams, different polarizations including linear, circular, and elliptical, and the use of single ended signals or differentially fed signals.

**[0093]** In an exemplary embodiment, an electronically steerable phased array antenna comprises a radiating element array, an active vector generator, and a DAC. In one exemplary embodiment, the DAC is reconfigurable to oper-

ate the phased array antenna in numerous configurations. For example, the phased array antenna can support multiple frequency bands and be reprogrammed to change between different polarization types. The reconfiguration can be made after the antenna architecture is fabricated.

**[0094]** In accordance with an exemplary embodiment, a phased array antenna comprises active components manufactured on silicon germanium (SiGe) in a monolithic solution. Other materials may be used, such as GaAs, silicon, or other suitable materials now known or hereinafter devised. A monolithic SiGe embodiment using active components results in certain advantages over the distributed/passive network in the prior art, including lower cost, smaller physical size, wider operating bandwidths, and the ability to provide power gain rather than a power loss.

**[0095]** Additionally, other advantages over the prior art embodiments are possible, depending on the phased array architecture. Some of the advantages include extensive system flexibility and very compact antenna systems because no distributed structures are required. In one embodiment, the size of the control function components of the phased array architecture is compact and independent of operating frequency. Furthermore, some embodiments employ differential signaling to improve signal isolation when the RF signal is in analog form.

**[0096]** Some of the main advantages include that RF signals undergo a neutral or slight positive gain when being communicated through the antenna system, rather than losses that occur in the passive prior art systems. Another advantage is that the antenna system is not band limited. In other words, the antenna system is applicable to all frequency bands, including X, K, Ku, Ka, and Q bands. Furthermore, in an exemplary embodiment, the antenna system is configured to operate, after manufacture or installation, at a first frequency range and subsequently operate at a second frequency range not equal to the first frequency range. In another exemplary embodiment, the antenna system is configured to operate at the first frequency range and the second frequency range simultaneously. In an exemplary embodiment, multi-band antennas are a practical option as a product.

**[0097]** Reconfigurability of the antenna system is also an advantage. This includes the ability to reconfigure the number of phase bits over full product life, being able to reconfigure the amplitude taper of the system over full product life, and being able to reconfigure the system polarization over full product life.

**[0098]** Described below are various specific phased array antenna system embodiments. The embodiments vary in terms of polarization, transmit or receive modes, and whether differential signaling is implemented.

**[0099]** Active Antenna Polarizer:

**[0100]** Overall, an active antenna polarizer is a digitally controlled active implementation for processing an RF signal. In accordance with an exemplary embodiment, the polarization and amplitude of a phased array radiating element is adjustable by operating two vector generators in parallel and feeding both output signals of the two vector generators to the radiating element in a spatially orthogonal fashion. The phased array antenna is configured to electrically change between polarizations. For example, the phased array antenna may alternate between linear polarization and circular polarization. In a first embodiment, the system achieves linear polarization by using a single vector gen-

erator to drive the radiating element. In a second embodiment, the system achieves circular polarization by using two vector generators to drive the radiating element in a spatially orthogonal fashion with two vectors that are electrically 90° out of phase from each other. In a third embodiment, the system achieves elliptical polarization by using two vector generators to drive the radiating element in a spatially orthogonal fashion with two vectors that are electrically out of phase by a value other than 90° with each other.

**[0101]** In an exemplary embodiment, the active antenna polarizer comprises discrete active components. In another exemplary embodiment, an active polarizer comprises a monolithic solution of active components. In yet another exemplary embodiment, the active antenna polarizer comprises a combination of discrete components and a monolithic solution.

**[0102]** In an exemplary embodiment and with reference to FIG. 7, a transmit active antenna polarizer 700 comprises an active power splitter 710, two vector generators 720, 721, and two DACs 730, 731. An RF input signal is actively split and transmitted through two vector generators 720, 721 in parallel. The vector generators 720, 721 are controlled by DACs 730, 731 respectively, and each vector generator produces a linear output signal. These two linear outputs can be used to energize/drive the spatially orthogonal feed ports of a radiating element (not shown).

**[0103]** The transmit active antenna polarizer 700 may be considered a basic transmit embodiment, which is configured to be implemented in a variety of different phased array antenna architectures. In an exemplary embodiment, the basic transmit embodiment is used in any frequency band and with different polarizations. For example, and as described below, the basic transmit embodiment may be used as the basis for at least one of beam steering and the phased array antenna transmitting in linear polarization, circular polarization, or elliptical polarization. In accordance with an exemplary embodiment, in order to operate in these different polarizations, vector generators 720, 721 control the phase of the antenna signal. In another embodiment, vector generators 720, 721 are configured for beam steering in conjunction with polarization control.

**[0104]** In an exemplary embodiment, reconfiguration of DACs 730, 731 allows the number of phase bits to be digitally controlled after transmit active antenna polarizer 700 is fabricated if adequate DAC resolution and AGC dynamic range exists. In an exemplary embodiment with adequate DAC resolution and AGC dynamic range, any desired vector phase and amplitude can be produced with selectable fine quantization steps using digital control. In another exemplary embodiment, reconfiguration of DACs 730, 731 can be made after transmit active antenna polarizer 700 is fabricated in order to facilitate adjustment of the signal amplitudes.

**[0105]** Reconfigurability of the antenna system is also an advantage. In an exemplary embodiment, the antenna system includes the ability to reconfigure the number of phase bits in a DAC over full product life. In another exemplary embodiment, the antenna system is able to reconfigure the amplitude taper of the system over full product life. In yet another exemplary embodiment, the antenna system is able to reconfigure the system polarization over full product life. Moreover, in an exemplary embodiment with adequate DAC resolution and AGC dynamic range, any desired vector

phase and amplitude can be produced with selectable fine quantization steps using digital control.

**[0106]** In an exemplary embodiment, the vector generators are controlled by software and digital hardware, and the antenna polarization is software definable. In other words, software may be implemented to control the antenna polarization by modifying the operating parameters of the vector generators via the DACs or other digital control. The operating parameters, for example, may include the relative phase between the outputs of the vector generators. In an exemplary embodiment, software controls the phase change by programming the DACs to achieve the desired phase relationship. Moreover, in an exemplary embodiment, the polarization of the energy radiated from the antenna is controlled in real-time. This results in a completely electronic technique where software allows continuous dynamic adjustment of the polarization of dual polarization feed antennas.

**[0107]** A receive active antenna is similar to a transmit active antenna as already described. In an exemplary embodiment, two RF input signals are communicated from a radiating element. The two RF input signals are processed in parallel through two vector generators before being combined by an active combiner. A receive active antenna polarizer may be considered a basic receive embodiment which is configured to be implemented in a variety of different phased array antenna architectures. In an exemplary embodiment, the basic receive embodiment is used in any frequency band and with different polarizations. For example, the basic receive embodiment may be used as the basis for at least one of beam steering and the phased array antenna receiving in linear polarization, circular polarization, or elliptical polarization. In accordance with an exemplary embodiment, in order to operate in these different polarizations, the vector generators control the phase of the antenna signal as described herein.

**[0108]** In accordance with an exemplary embodiment, an active antenna polarizer is configured to dynamically change the polarization of an antenna using radiating elements with dual-polarized feeds. Furthermore, in an exemplary embodiment, an antenna is configured to statically or dynamically control the polarization of the antenna on a subarray or individual element basis in order to optimize a performance characteristic associated with polarization. Examples of such polarization associated characteristics include polarization loss factors and polarization efficiency. In an exemplary embodiment, the use of dual-polarized feeds facilitates the performance optimization. For example, in an exemplary embodiment, a maximum signal level may be obtained by varying the polarization around an expected value until the optimal level is set. The difference between the expected value and the optimal value may occur due to various factors. For example, objects may be present in the signal path. As another example, manufacturing tolerances may result in the physical structure being in a less-optimal position. In still another example, inclement weather can result in one polarization performing better than another polarization. In other words, an exemplary antenna is configured to adjust the polarization in order to compensate for manufacturing tolerances, weather, inferring objects, and the like. In an exemplary embodiment, a polarization sweep is performed in order to receive different signals which can be used for signal identification.

**[0109]** FIG. 8 shows an exemplary embodiment of a phased array antenna **800** configured to transmit a signal with linear polarization. Phased array antenna **800** comprises an active power splitter **810**, a first vector generator **820**, a second vector generator **821**, a first DAC **830**, and a second DAC **831**. Phased array antenna **800** is a basic transmit embodiment with an output signal of first vector generator **820** energizing a radiating element **801** and with second vector generator **821** not in communication with radiating element **801**. In an alternative but similar embodiment, second vector generator **821** energizes radiating element **801** with first vector generator **820** not in communication with radiating element **801**. Additionally, radiating element **801** can have a “horizontal” orientation or a “vertical” orientation. In the exemplary embodiment, the basic transmit embodiment with two vector generators **820**, **821** is implemented in order to demonstrate that a standard architecture may be used in numerous antenna types. This enables cost benefits because the same underlying component is used instead of different, more customized components.

**[0110]** In another exemplary embodiment, a phased array antenna, configured to transmit a signal with linear polarization, comprises only one vector generator and a controlling DAC. As one skilled in the art understands, the embodiments described herein that manipulate only one vector generator output can comprise only a single vector generator. In other words, in one embodiment, phased array antenna **800** comprises first vector generator **820** but not second vector generator **821** or active power splitter **810**.

**[0111]** In contrast, a dual linear polarization antenna communicates two signals to a radiating element. In an exemplary embodiment and with reference to FIG. 9, a phased array antenna **900** is configured to transmit a signal with dual linear polarization. Phased array antenna **900** comprises an active power splitter **910**, a first vector generator **920**, a second vector generator **921**, a first DAC **930**, and a second DAC **931**. Phased array antenna **900** is a basic transmit embodiment with the two vector generator output signals energizing a radiating element **901**, in both the horizontal and vertical orientations. Furthermore, the output signals of vector generators **920**, **921** can have any relative phase between the two signals. In a circular polarization embodiment, the output signal of vector generator **920** has a  $\pm 90^\circ$  relative phase difference with the output signal of vector generator **921** when energizing radiating element **901**. In an exemplary embodiment with elliptical polarization, the output signal of vector generator **920** has a relative phase difference other than  $\pm 90^\circ$  with the output signal of vector generator **921** when energizing radiating element **901**.

**[0112]** FIG. 10 shows an exemplary embodiment of a phased array antenna **1000** configured to receive a signal with linear polarization. Phased array antenna **1000** comprises an active power combiner **1010**, a first vector generator **1020**, a second vector generator **1021**, a first DAC **1030** and a second DAC **1031**. Phased array antenna **1000** is a basic receive embodiment with one of vector generators **1020**, **1021** communicating a signal from a radiating element **1001** to active power combiner **1010** and the other of vector generators **1020**, **1021** not being in communication with radiating element **1001**. Additionally, radiating element **1001** can have a horizontal or vertical orientation.

**[0113]** In another exemplary embodiment, a phased array antenna is configured to receive a signal with linear polarization and comprises only one vector generator and corre-

sponding controlling DAC. As would be known to one skilled in the art, various embodiments described herein that manipulate only one vector generator output may comprise only one vector generator. In other words, in one embodiment, phased array antenna **1000** comprises first vector generator **1020** but not second vector generator **1021** or active combiner **1010**.

[0114] In contrast, a dual linear polarization antenna communicates two signals from a radiating element. In an exemplary embodiment and with reference to FIG. **11**, a phased array antenna **1100** is configured to receive a signal with dual linear polarization. Phased array antenna **1100** comprises an active power combiner **1110**, a first vector generator **1120**, a second vector generator **1121**, a first DAC **1130**, and a second DAC **1131**. Phased array antenna **1100** is a basic receive embodiment with vector generators **1120**, **1121** receiving individual polarized signals from radiating element **1101** as input signals. The individual polarized signals may be a horizontal oriented signal and a vertical oriented signal. Furthermore, the input signals of vector generators **1120**, **1121** can have any relative phase between the two signals. In a circular polarization embodiment, the input signal of vector generator **1120** has a  $\pm 90^\circ$  relative phase difference with the input signal of vector generator **1121** when received from radiating element **1101**. In an exemplary embodiment with elliptical polarization, the input signal of vector generator **1120** has a relative phase difference other than  $\pm 90^\circ$  with the input signal of vector generator **1121** when received from radiating element **1101**.

[0115] FIG. **12** shows an exemplary embodiment of a phased array antenna **1200** configured to transmit a signal with differentially fed linear polarization. Phased array antenna **1200** comprises an active power splitter **1210**, a first vector generator **1220**, a second vector generator **1221**, a first DAC **1230** and a second DAC **1231**. Phased array antenna **1200** is a basic transmit embodiment with a differential output signal from one of vector generators **1220**, **1221** energizing a radiating element **1201**. As is known to one in the art, a differential signal has two signals are  $180^\circ$  out of phase from each other. In various embodiments, the differential signal may be fed into the “horizontal” portions of radiating element **1201** or into the “vertical” portions of radiating element **1201**.

[0116] In another exemplary embodiment, a phased array antenna configured to transmit a differential signal with linear polarization comprises only one vector generator and a controlling DAC. As one skilled in the art understands, the embodiments described herein that manipulate only one vector generator output can comprise only a single vector generator. In other words, in one embodiment, phased array antenna **1200** comprises first vector generator **1220** but not second vector generator **1221** or active power splitter **1210**.

[0117] In contrast, a dual linear polarization antenna communicates two differentially fed signals to a radiating element. In an exemplary embodiment and with reference to FIG. **13**, a phased array antenna **1300** is configured to transmit differential signals with dual linear polarization. Phased array antenna **1300** comprises an active power splitter **1310**, a first vector generator **1320**, a second vector generator **1321**, a first DAC **1330**, and a second DAC **1331**. Phased array antenna **1300** is a basic transmit embodiment with a first differentially fed output signal of vector generator **1320** and a second differentially fed output signal of vector generator **1321** energizing a radiating element **1301**.

In an exemplary embodiment, the first differentially fed output signal is fed into radiating element **1301** in a vertical orientation. Furthermore, in the exemplary embodiment, the second differentially fed output signal is fed into radiating element **1301** in a horizontal orientation. Moreover, the first differentially fed output signal of vector generator **1320** and the second differentially fed output signal of vector generator **1321** can have any relative phase between the two signals. In a circular polarization embodiment, the first differentially fed output signal of vector generators **1320** has a  $\pm 90^\circ$  relative phase difference with the second differentially fed output signal of vector generator **1321** when energizing radiating element **1301**. In an exemplary embodiment with elliptical polarization, the first differentially fed output signal of vector generator **1320** has a relative phase difference other than  $\pm 90^\circ$  with the second differentially fed output signal of vector generator **1321** when energizing radiating element **1301**.

[0118] FIG. **14** shows an exemplary embodiment of a phased array antenna **1400** configured to receive a signal with differentially fed horizontal linear polarization. Phased array antenna **1400** comprises an active power combiner **1410**, a first vector generator **1420**, a second vector generator **1421**, a first DAC **1430** and a second DAC **1431**. Phased array antenna **1400** is a basic receive embodiment with one of vector generators **1420**, **1421** receiving a differential input signal from a radiating element **1401** and communicating an output signal to active power combiner **1410**. In one embodiment, and similar to phased array antenna **800**, the other of vector generators **1420**, **1421** is not in communication with radiating element **1401**. Furthermore, the differential signal may be received from the “horizontal” portions of radiating element **1401** or from the “vertical” portions of radiating element **1401**.

[0119] In another exemplary embodiment, a phased array antenna is configured to receive a signal with differentially fed horizontal linear polarization and comprises only one vector generator and corresponding controlling DAC. As would be known to one skilled in the art, various embodiments described herein that manipulate only one vector generator input may comprise only one vector generator. In other words, in one embodiment, phased array antenna **1400** comprises first vector generator **1420** but not second vector generator **1421** or active combiner **1410**.

[0120] In contrast, a dual linear polarization antenna communicates two differentially fed signals from a radiating element. In an exemplary embodiment and with reference to FIG. **15**, a phased array antenna **1500** is configured to receive differential signals with dual linear polarization. Phased array antenna **1500** comprises an active power combiner **1510**, a first vector generator **1520**, a second vector generator **1521**, a first DAC **1530**, and a second DAC **1531**. Phased array antenna **1500** is a basic receive embodiment with vector generator **1520** receiving a first differentially fed input signal and vector generator **1521** receiving a second differentially fed input signal from a radiating element **1501**. In an exemplary embodiment, the first differentially fed input signal is received from radiating element **1501** in a vertical orientation. Furthermore, in the exemplary embodiment, the second differentially fed input signal is received from radiating element **1501** in a horizontal orientation. Moreover, the first and second differentially fed input signals of vector generators **1520**, **1521** can have any relative phase between the two signals. In a circular polar-

ization embodiment, the first differentially fed input signal of vector generator 1520 has a  $\pm 90^\circ$  relative phase difference with the second differentially fed input signal of vector generator 1521 when received from radiating element 1501. In an exemplary embodiment with elliptical polarization, the first differentially fed output signal of vector generator 1520 has a relative phase difference other than  $\pm 90^\circ$  with the second differentially fed output signal of vector generator 1521 when energizing radiating element 1501.

[0121] The various phased array antenna embodiments described above may be implemented into multiple radiating element architecture. Furthermore, the multiple radiating elements are scalable in terms of both radiating elements and beam forming. An embodiment with vector generators in communication with individual radiating elements facilitates additional beams while using the same radiating aperture. Furthermore, the radiating element transmitter/receiver may comprise various numbers of radiating elements. For example, the antenna architecture could comprise multiple radiating elements in the range of 2-20.

[0122] In accordance with an exemplary embodiment, and with reference to FIG. 16, a phased array integrated circuit (IC) 1600 is configured as a 4-radiating element transmitter. The phased array IC 1600 comprises a first subcircuit 1610 in communication with a first radiating element 1611, a second subcircuit 1620 in communication with a second radiating element 1621, a third subcircuit 1630 in communication with a third radiating element 1631, and a fourth subcircuit 1640 in communication with a fourth radiating element 1641. Each subcircuit 1610, 1620, 1630, 1640 receives an input signal and transmits the signal to the spatially orthogonal ports of the respective radiating element 1611, 1621, 1631, 1641.

[0123] In accordance with an exemplary embodiment, an RF input signal is provided to phased array IC 1600. In an exemplary embodiment, multiple splitters are used to divide the RF input signal that is communicated to each of four subcircuits 1610, 1620, 1630, 1640 as input signals. In a more specific exemplary embodiment, a balun may be implemented to convert the RF input signal into a differential RF input signal. Differential signaling may improve signal isolation and interference rejection if the RF signal is in analog form. An active splitter 1653 is configured to divide the differential RF input signal into two separate signals that are communicated to an active splitter 1651 and an active splitter 1652, respectively. At the next stage, active splitter 1651 is configured to divide the communicated signal and communicate the divided signals to first subcircuit 1610 and second subcircuit 1620. Similarly, active splitter 1652 is configured to divide the communicated signals and communicate the divided signals to third subcircuit 1630 and fourth subcircuit 1640.

[0124] The structure and function of each subcircuit 1610, 1620, 1630, 1640 is substantially similar. Thus, only first subcircuit 1610 will be discussed in detail. Moreover, subcircuit 1610 is substantially similar to transmit active antenna polarizer 700. In accordance with an exemplary embodiment, first subcircuit 1610 comprises a first vector generator 1612 controlled by a first DAC (not shown), a second vector generator 1613 controlled by a second DAC (not shown), and an active splitter 1615. Though the signals communicated in phased array IC 1600 may be described as differential, the signals may also be single-ended. Active splitter 1615 receives a differential signal from active splitter

1651, and divides the differential signal once again. In an exemplary embodiment, vector generators 1612, 1613 individually receive a differential signal from active splitter 1615. Furthermore, vector generators 1612, 1613 are configured to adjust the phase and polarization of the signals to be transmitted so that individual beam steering and polarization control may be achieved. Vector generators 1612, 1613 afford two degrees of freedom to polarization track and beam steer. For circular or elliptical polarization and single beam steering, one of the vector generators can provide the beam steering while the other vector generator can provide an offset phase to track the polarization.

[0125] The polarized signals are then communicated from vector generators 1612, 1613 to the spatially orthogonal ports of radiating element 1611 for transmission. In an exemplary embodiment, a digital control 1601 communicates polarization and beam steering commands to vector generators 1612, 1613 via the respective DACs.

[0126] In addition to a 1-beam, 4-radiating element transmitter, a similar structure may be configured as a 1-beam, 4-radiating element receiver. In an exemplary embodiment and with reference to FIG. 17, a phased array integrated circuit 1700 is configured as a 1-beam, 4-radiating element receiver. The phased array IC 1700 comprises a first subcircuit 1710 in communication with a first radiating element 1711, a second subcircuit 1720 in communication with a second radiating element 1721, a third subcircuit 1730 in communication with a third radiating element 1731, and a fourth subcircuit 1740 in communication with a fourth radiating element 1741. Each subcircuit 1710, 1720, 1730, 1740 receives a pair of spatially orthogonal RF signals from the respectively coupled radiating element 1711, 1721, 1731, 1741 and generates a single output signal.

[0127] The structure and function of each subcircuit 1710, 1720, 1730, 1740 is substantially similar. Thus, only first subcircuit 1710 will be discussed in detail. In accordance with an exemplary embodiment, first subcircuit 1710 has a polarization tracking and single beam steering portion comprising two vector generators 1712, 1713. The two vector generators 1712, 1713 are configured to receive the RF input signal from radiating element 1711, provide beam steering, track the polarization of the signals, and communicate the vector generator output signals to an active power combiner 1715. Vector generators 1712, 1713 afford two degrees of freedom to polarization track and beam steer. For circular or elliptical polarization and single beam steering, one of the vector generators can provide the beam steering while the other vector generator can provide an offset phase to track the polarization. The active power combiner 1715 combines the two vector generator output signals and generates a composite output signal.

[0128] In an exemplary embodiment, a digital control 1701 communicates polarization and beam steering commands to vector generators 1712, 1713, for example, via corresponding DACs.

[0129] In accordance with an exemplary embodiment, a receive beam output is generated by combining the single output signal from each of four subcircuits 1710, 1720, 1730, 1740. In an exemplary embodiment, multiple combiners are used to combine the subcircuit output signals into a receive beam. In a more specific exemplary embodiment, an active combiner 1751 is configured to combine the single outputs from first and second subcircuits 1710, 1720. Also in the exemplary embodiment, an active combiner 1752 is



configured to combine the single outputs from third and fourth subcircuits **1730**, **1740**. At the next stage, an active combiner **1753** is configured to combine the combined outputs of active combiners **1751**, **1752** to form a receive beam output.

**[0130]** In addition to a 1-beam 4-radiating element antenna, a similar structure may be configured as a 2-beam 4-radiating element antenna. In an exemplary embodiment and with reference to FIG. **18**, a phased array integrated circuit **1800** is configured as a 2-beam, 4-radiating element receiver. The phased array IC **1800** comprises a first subcircuit **1810** in communication with a first radiating element **1811**, a second subcircuit **1820** in communication with a second radiating element **1821**, a third subcircuit **1830** in communication with a third radiating element **1831**, and a fourth subcircuit **1840** in communication with a fourth radiating element **1841**. Each subcircuit **1810**, **1820**, **1830**, **1840** receives a pair of spatially orthogonal RF signals from the respectively coupled radiating element **1811**, **1821**, **1831**, **1841** and generates two output signals, one for each beam to be formed.

**[0131]** The structure and function of each subcircuit **1810**, **1820**, **1830**, **1840** is substantially similar. Thus, only first subcircuit **1810** will be discussed in detail. In accordance with an exemplary embodiment, first subcircuit **1810** has a polarization forming portion comprising two vector generators **1812**, **1813**. The two vector generators **1812**, **1813** are configured to receive the RF input signals from radiating element **1811**, polarization track the signals, and transmit the vector generator output signals to an active power combiner **1815**. The active power combiner **1815** combines the two vector generator output signals and generates a composite intermediate signal. The composite intermediate signal is communicated from active power combiner **1815** to an active power splitter **1816**. The active power splitter **1816** divides the intermediate signal into two signals, one for each beam, with each of the two output signals passing through a beam forming portion of subcircuit **1810**. The beam forming portion comprises two vector generators **1818**, **1819**, whose outputs represent independently steered beam components to be combined in the respective beam forming network. In an exemplary embodiment, a digital control **1801** communicates polarization and beam steering commands to vector generators **1812**, **1813**, **1818**, **1819**.

**[0132]** In accordance with an exemplary embodiment, a first receive beam output is generated by combining one of the two output signals from each of four subcircuits **1810**, **1820**, **1830**, **1840**. A second receive beam output is generated by combining the second of the two output signals from each of four subcircuits **1810**, **1820**, **1830**, **1840**. In an exemplary embodiment, multiple combiners are used to combine the subcircuit output signals into a first receive beam output and a second receive beam output.

**[0133]** In a more specific exemplary embodiment, an active combiner **1851** is configured to combine the first of the two outputs from first and second subcircuits **1810**, **1820**. Furthermore, an active combiner **1861** is configured to combine the second of the two outputs from first and second subcircuits **1810**, **1820**. Also in the exemplary embodiment, an active combiner **1852** is configured to combine the first of the two outputs from third and fourth subcircuits **1830**, **1840**. An active combiner **1862** is configured to combine the second of the two outputs from third and fourth subcircuits **1830**, **1840**.

**[0134]** At the next stage, an active combiner **1853** is configured to combine the combined outputs of active combiners **1851** and **1852** to form a first receive beam output. Furthermore, an active combiner **1863** is configured to combine the combined outputs of active combiners **1861** and **1862** to form a second receive beam output.

**[0135]** In addition to a 2-beam, 4-radiating element receiver, a similar structure may be configured as a 2-beam, 4-radiating element transmitter. In an exemplary embodiment, and with reference to FIG. **19**, a phased array integrated circuit **1900** is configured as a 2-beam, 4-radiating element transmitter. The phased array IC **1900** comprises a first subcircuit **1910** in communication with a first radiating element **1911**, a second subcircuit **1920** in communication with a second radiating element **1921**, a third subcircuit **1930** in communication with a third radiating element **1931**, and a fourth subcircuit **1940** in communication with a fourth radiating element **1941**. Each subcircuit **1910**, **1920**, **1930**, **1940** receives two input signals and transmits signals to the spatially orthogonal ports of the respectively coupled radiating element **1911**, **1921**, **1931**, **1941**.

**[0136]** In accordance with an exemplary embodiment, a first transmit beam and a second transmit beam are provided to phased array IC **1900**. In an exemplary embodiment, multiple splitters are used to divide the first and second transmit beams that are communicated to each of four subcircuits **1910**, **1920**, **1930**, **1940** as input signals.

**[0137]** In a more specific exemplary embodiment, an active splitter **1953** is configured to divide the first transmit beam input into two separate signals that are communicated to an active splitter **1951** and an active splitter **1952**, respectively. Similarly, an active splitter **1963** is configured to divide the second transmit beam input into two separate signals that are communicated to an active splitter **1961** and an active splitter **1962**, respectively.

**[0138]** At the next stage, active splitters **1951**, **1961** are configured to divide the communicated signals and communicate the divided signals to first subcircuit **1910** and second subcircuit **1920**. The active splitters **1952**, **1962** are configured to divide the communicated signals and communicate the divided signals to third subcircuit **1930** and fourth subcircuit **1940**.

**[0139]** The structure and function of each subcircuit **1910**, **1920**, **1930**, **1940** is substantially similar. Thus, only first subcircuit **1910** will be discussed in detail. In accordance with an exemplary embodiment, first subcircuit **1910** has a beam forming portion comprising two vector generators **1918**, **1919**. The two vector generators **1918**, **1919** are configured to individually receive an input signal from active splitters **1951**, **1961**, respectively and adjust the phase according to beam steering commands.

**[0140]** An active power combiner **1915** combines the two phase-adjusted signals and generates a composite phase-adjusted intermediate signal. The composite phase-adjusted intermediate signal is communicated from active power combiner **1915** to an active power splitter **1916**. The active power splitter **1916** divides the intermediate signal into two splitter output signals, with each of the two splitter output signals passing through a polarization modifying portion of first subcircuit **1910**. The polarization modifying portion comprises vector generators **1912**, **1913**, and is configured to polarize the output signals to the desired polarization. The polarized signals are then communicated to the spatially orthogonal ports of radiating element **1911** for transmission.

In an exemplary embodiment, a digital control **1901** communicates polarization and beam steering commands to vector generators **1912, 1913, 1918, 1919**.

[0141] In an exemplary embodiment and with reference to FIG. **20**, a phased array integrated circuit **2000** is configured as a 4-beam, 4-radiating element receiver. The phased array IC **2000** comprises a first subcircuit **2010** in communication with a first radiating element **2011**, a second subcircuit **2020** in communication with a second radiating element **2021**, a third subcircuit **2030** in communication with a third radiating element **2031**, and a fourth subcircuit **2040** in communication with a fourth radiating element **2041**. Each subcircuit **2010, 2020, 2030, 2040** receives a pair of spatially orthogonal RF signals from the respectively coupled radiating element **2011, 2021, 2031, 2041** and generates four output signals, one for each beam to be formed.

[0142] The structure and function of each subcircuit **2010, 2020, 2030, 2040** is substantially similar. Thus, only first subcircuit **2010** will be discussed in detail. In accordance with an exemplary embodiment, first subcircuit **2010** has a polarization tracking portion comprising two vector generators **2012, 2013**. The two vector generators **2012, 2013** are configured to receive the RF input signal from radiating element **2011**, track the polarization of the signals, and transmit vector generator signal outputs to an active power combiner **2014**. The active power combiner **2014** combines the two vector generator signal outputs and generates a composite intermediate signal. The composite intermediate signal is communicated from active power combiner **2014** to an active power splitter **2015**. The active power splitter **2015** divides the intermediate signal into four signals, with each of the four output signals passing through a beam forming portion of subcircuit **2010**. The beam forming portion comprises four vector generators **2016, 2017, 2018, 2019**, whose outputs represent independently steered beam components to be combined in the respective beam forming network. In an exemplary embodiment, a digital control **2001** communicates polarization and beam steering commands to vector generators **2012, 2013, 2016, 2017, 2018, 2019**.

[0143] In accordance with an exemplary embodiment, a first receive beam output is generated by combining one of the four output signals from each of four subcircuits **2010, 2020, 2030, 2040**. A second receive beam output is generated by combining a second of the four output signals from each of four subcircuits **2010, 2020, 2030, 2040**. A third receive beam output is generated by combining a third of the four output signals from each of four subcircuits **2010, 2020, 2030, 2040**. A fourth receive beam output is generated by combining a fourth of the four output signals from each of four subcircuits **2010, 2020, 2030, 2040**. In an exemplary embodiment, multiple combiners are used to combine the subcircuit output signals into the four receive beam outputs.

[0144] In a more specific exemplary embodiment, an active combiner **2051** is configured to combine the first of the four outputs from first and second subcircuits **2010, 2020**. Furthermore, an active combiner **2061** is configured to combine the second of the four outputs from first and second subcircuits **2010, 2020**. Likewise, an active combiner **2071** is configured to combine the third of the four outputs from first and second subcircuits **2010, 2020**. An active combiner **2081** is configured to combine the fourth of the four outputs from first and second subcircuits **2010, 2020**.

[0145] Also in the exemplary embodiment, an active combiner **2052** is configured to combine the first of the two

outputs from third and fourth subcircuits **2030, 2040**. An active combiner **2062** is configured to combine the second of the four outputs from third and fourth subcircuits **2030, 2040**. Furthermore, an active combiner **2072** is configured to combine the third of the four outputs from third and fourth subcircuits **2030, 2040**. An active combiner **2082** is configured to combine the fourth of the four outputs from third and fourth subcircuits **2030, 2040**.

[0146] At the next stage, an active combiner **2053** is configured to combine the combined outputs of active combiners **2051, 2052** to form a first receive beam output. An active combiner **2063** is configured to combine the combined outputs of active combiners **2061, 2062** to form a second receive beam output. Furthermore, an active combiner **2073** is configured to combine the combined outputs of active combiners **2071, 2072** to form a third receive beam output. An active combiner **2083** is configured to combine the combined outputs of active combiners **2081, 2082** to form a fourth receive beam output.

[0147] In an exemplary embodiment, and with reference to FIG. **21**, a phased array integrated circuit **2100** is configured as a 4-beam, 4-radiating element transmitter. The phased array IC **2100** comprises a first subcircuit **2110** in communication with a first radiating element **2111**, a second subcircuit **2120** in communication with a second radiating element **2121**, a third subcircuit **2130** in communication with a third radiating element **2131**, and a fourth subcircuit **2140** in communication with a fourth radiating element **2141**. Each subcircuit **2110, 2120, 2130, 2140** receives four input signals and transmits RF signals to the spatially orthogonal ports of the respectively coupled radiating element **2111, 2121, 2131, 2141**.

[0148] In accordance with an exemplary embodiment, a first, second, third, and fourth transmit beam are provided to phased array IC **2100**. In an exemplary embodiment, multiple splitters are used to divide the first, second, third, and fourth transmit beams that are communicated to each of four subcircuits **2110, 2120, 2130, 2140** as input signals.

[0149] In a more specific exemplary embodiment, an active splitter **2153** is configured to divide the first transmit beam input into two separate signals that are communicated to an active splitter **2151** and an active splitter **2152**, respectively. Similarly, an active splitter **2163** is configured to divide the second transmit beam input into two separate signals that are communicated to an active splitter **2161** and an active splitter **2162**, respectively. In an exemplary embodiment, an active splitter **2173** is configured to divide the third transmit beam input into two separate signals that are communicated to an active splitter **2171** and an active splitter **2172**, respectively. Furthermore, an active splitter **2183** is configured to divide the fourth transmit beam input into two separate signals that are communicated to an active splitter **2181** and an active splitter **2182**, respectively.

[0150] At the next stage, active splitters **2151, 2161, 2171, 2181** are configured to divide the communicated signals and communicate the divided signals to first subcircuit **2110** and second subcircuit **2120**. The active splitters **2152, 2162, 2172, 2182** are configured to divide the communicated signals and communicate the divided signals to third subcircuit **2130** and fourth subcircuit **2140**.

[0151] The structure and function of each subcircuit **2110, 2120, 2130, 2140** is substantially similar. Thus, only first subcircuit **2110** will be discussed in detail. In accordance with an exemplary embodiment, first subcircuit **2110** has a

beam forming portion comprising four vector generators **2116**, **2117**, **2118**, **2119**. The four vector generators **2116**, **2117**, **2118**, **2119** are configured to individually receive an input signal from active splitters **2151**, **2161**, **2171**, **2181**, respectively and adjust the phase according to beam steering commands.

**[0152]** An active power combiner **2114** combines the four phase-adjusted signals and generates a composite phase-adjusted intermediate signal. The composite phase-adjusted intermediate signal is communicated from active power combiner **2114** to an active power splitter **2115**. The active power splitter **2115** divides the intermediate signal into two signals, with each of the two output signals passing through a polarization modifying portion of first subcircuit **2110**. The polarization modifying portion comprises vector generators **2112**, **2113**, and is configured to polarize the output signals to the desired polarization. The polarized signals are then communicated to the spatially orthogonal ports of radiating element **2111** for transmission. In an exemplary embodiment, a digital control **2101** communicates polarization and beam steering commands to vector generators **2112**, **2113**, **2116**, **2117**, **2118**, **2119**, for example, via DACs.

**[0153]** In addition to the various embodiments described above, other architectures are possible. For example, in an exemplary embodiment and with reference to FIG. **22**, a phased array integrated circuit **2200** is configured as a 2-beam, 4-radiating element receiver for circular or elliptical polarizations. As illustrated in a first subcircuit **2210** of phased array IC **2200**, the difference between phased array IC **1810** is that only one vector generator **2212** is present in the polarization forming portion. A single vector generator **2212** is sufficient for polarization tracking of circular or elliptical polarizations. In an exemplary embodiment, vector generator **2212** tracks the polarizations by providing the 90° offset (or non-90° phase offset if elliptical) to the phase of the signal appearing at the alternate spatially orthogonal port of radiating element **2211**. The rest of phased array IC **2200** is similar to phased array IC **1810**, and will not be described in detail though various components are similarly referenced. Similar variations are possible in the embodiments illustrated in FIGS. **19-21**, with circular or elliptical polarization embodiments using only a single vector generator for polarization tracking.

**[0154]** Multi-Beam Operation: In addition to the multiple radiating elements embodiments described above, various beam forming networks may be designed using multiple radiating elements and forming multiple beams. In accordance with an exemplary embodiment and with reference to FIG. **23**, a multi-beam architecture **2300** comprises multiple radiating elements ( $RE_1, RE_2, \dots, RE_N$ ) with each radiating element being in communication with an active polarization control ( $PC_1, PC_2, \dots, PC_N$ ). The multi-beam architecture **2300** further comprises at least one beam forming network ( $BFN_1, BFN_2, \dots, BFN_M$ ) and at least one phase shifter connected to the active polarization control ( $PC_1, PC_2, \dots, PC_N$ ) per beam forming network ( $BFN_1, BFN_2, \dots, BFN_M$ ). In an exemplary embodiment, each radiating element is in communication with M phase shifters, and each phase shifter is in communication with one of M beam forming networks so that each beam forming network receives a signal from each of the N radiating elements.

**[0155]** In an exemplary embodiment, the phase shifters may be active vector generators or any other component suitable to phase shift the signals. Furthermore, the beam

forming networks and summing junctions can be passive or active. Moreover, a multi-beam architecture may similarly be implemented for transmission of RF signals.

**[0156]** With further reference to FIG. **23**, the active polarization control functions ( $PC_1, PC_2, \dots, PC_N$ ) can be any of the embodiments previously listed herein. Connected to each of the active polarization control functions is a power splitter (for receive applications) or power combiner (for transmit applications). The power splitter or power combiner can be implemented as a passive or active structure as described previously herein. In communication with the power splitter/combiner is a set of vector generators where each vector generator provides a phase shift in support of a particular beam. In an exemplary embodiment, there are M vector generators at each radiating element to support M independently steerable beams. In an exemplary embodiment, the set of vector generators is in communication with a power combiner (for receive applications) or power splitter (for transmit applications) to complete the beam formation process. The power splitter or power combiner can be implemented as a passive or active structure as described previously herein.

**[0157]** In different various embodiments, a multi-beam multi-band architecture with a beam forming network in communication with a single radiating element is configured for forming and detecting circular polarized signals.

**[0158]** Receive Architecture:

**[0159]** In accordance with an exemplary embodiment and with reference to FIG. **24**, dual-polarization multi-beam receive architecture **2400** comprises active power splitters, vector generators, and active power combiners in communication with a radiating element **2401** to form multiple beams. In an exemplary embodiment, receive architecture **2400** forms at least one right-hand circular polarized (RHCP) beam and forms at least one left-hand circular polarized (LHCP) beam. More specifically, in an exemplary embodiment, receive architecture **2400** forms N RHCP beams and forms M LHCP beams.

**[0160]** Each beam, whether right-hand polarized or left-hand polarized, is formed using a similar component configuration. In an exemplary embodiment, a signal is received at radiating element **2401**, having a horizontal polarization and a vertical polarization. The vertical polarized signal is communicated to a first active power splitter **2410** and the horizontal polarized signal is communicated to a second active power splitter **2411**. Moreover, first active power splitter **2410** may be understood to comprise multiple active power splitters, and second active power splitter **2411** may be understood to comprise the same number of multiple active power splitters. In an exemplary embodiment, active power splitters **2410**, **2411** individually divide the signal into two or more signals, such that the vertical signal polarization and horizontal signal polarization are divided into a certain number of signals.

**[0161]** In an exemplary embodiment, each beam is formed using a first vector generator **2420**, a second vector generator **2421**, and an active power combiner **2430**. The first vector generator **2420** receives a vertical polarized signal from first active power splitter **2410**. First vector generator **2420** is configured to adjust at least one of the phase and amplitude of the vertical polarized signal for beam steering. Furthermore, second vector generator **2421** receives a horizontal polarized signal from second active power splitter **2411**. Second vector generator **2421** is configured to adjust at least

one of the phase and amplitude of the horizontal polarized signal for polarization tracking. In other embodiments, the vertical polarized signal is adjusted for polarization tracking and the horizontal polarized signal is adjusted for beam steering. In accordance with an exemplary embodiment, active power combiner **2430** receives two output signals, one signal from first vector generator **2420** and another signal from second vector generator **2421**. Active power combiner **2430** combines the two signals into a beam. The beam may be RHCP or LHCP, depending on the parameters of vector generators **2420**, **2421**. In an exemplary embodiment, receive architecture **2400** is configured to provide complete polarization flexibility on a beam by beam basis. However, receive architecture **2400** uses  $2*(M+N)$  vector generators to accomplish this complete flexibility.

**[0162]** In a circular polarization embodiment, fewer components are used in comparison to a complete polarization embodiment because circular polarization only needs  $\pm 90^\circ$  polarization tracking. Therefore, in an exemplary embodiment and with reference to FIG. **25**, a dual-polarization multi-beam receive architecture **2500** with circular polarization comprises active power splitters and vector generators in communication with a radiating element **2501** to form multiple beams.

**[0163]** In an exemplary embodiment, receive architecture **2500** forms at least one RHCP beam and forms at least one LHCP beam. As with the complete polarization embodiment, receive architecture **2500** may form up to N RHCP beams and M LHCP beams. Each beam, whether right-hand polarized or left-hand polarized, is formed using a similar component configuration. In an exemplary embodiment, a signal is received at radiating element **2501**, having a horizontal polarization component and a vertical polarization component. The vertical polarized signal is communicated to a first active power splitter **2510** and the horizontal polarized signal is communicated to a second active power splitter **2511**. Moreover, first active power splitter **2510** may be understood to comprise multiple active power splitters, and second active power splitter **2511** may be understood to comprise the same number of multiple active power splitters. In an exemplary embodiment, active power splitters **2510**, **2511** individually divide the signal into two or more signals, such that the vertical signal polarization and horizontal signal polarization are divided into a certain number of signals.

**[0164]** In an exemplary embodiment, each beam is formed using a vector generator **2520** and a quadrature allpass filter (QAF) **2540**. In an exemplary embodiment, QAF **2540** receives a vertical polarized signal from first active power splitter **2510** and a horizontal polarized signal from second active power splitter **2511**. QAF **2540** combines the vertical and horizontal polarized signals while injecting a nominally  $90^\circ$  relative phase shift between the two signals. The combined output signal is communicated from QAF **2540** to vector generator **2520**. Vector generator **2520** is configured to provide beam steering by adjusting at least one of the phase and amplitude of the combined signal.

**[0165]** The beam may be RHCP or LHCP, depending on the signal input connections with QAF **2540**. For example, to generate a RHCP beam, a vertical polarized signal is connected to an I vector input of QAF **2540** and a horizontal polarized signal is connected to a Q vector input of QAF **2540**. In contrast, to generate a LHCP beam, a vertical polarized signal is connected to the Q vector input of QAF

**2540** and a horizontal polarized signal is connected to the I vector input of QAF **2540**. In an exemplary embodiment, receive architecture **2500** provides circular polarization on each beam using  $(M+N)$  vector generators.

**[0166]** In another exemplary embodiment, a simpler component configuration of a dual-polarization multi-beam receive architecture with circular polarization is possible. Similar to receive architecture **2500**, in an exemplary embodiment, a receive architecture comprises a first active power splitter, a second active power splitter and a modified vector generator in communication with a radiating element. However, in contrast to receive architecture **2500**, no quadrature allpass filters are used. For each beam, and still using receive architecture **2500** as a reference, QAF **2540** is eliminated in conjunction with eliminating the QAF at the input of vector generator **2520**, resulting in a modified vector generator.

**[0167]** The elimination of the two QAF components is a result of redundancy. In receive architecture **2500**, QAF **2540** receives two input vectors, referred to as a Q vector and an I vector for convenience. With reference to similar vector generator **500**, vector generator **2520** also comprises a QAF that is separate and reversed from QAF **2540**. In vector generator **2520**, the QAF receives a single signal and generates a Q vector and an I vector. In an exemplary embodiment, the cascade of two reversed QAFs performs a redundant function and may be eliminated. In the exemplary embodiment, the vertical and horizontal polarized signals from the radiating element are connected to the phase inversion switches of a modified vector generator. The elimination of QAFs is possible if the QAFs are originally reversed of each other. In other words, reversed back-to-back QAFs injecting opposite phase shifts counteract each other and become expendable.

**[0168]** Eliminating the two QAFs achieves system advantages, such as eliminating the ohmic loss associated with each QAF, which may be about 3 dB. Another advantage is that the QAF is a bandwidth limiting element of the vector generator, resulting in the modified vector generator being capable of an expanded bandwidth.

**[0169]** Transmit Architecture:

**[0170]** In accordance with an exemplary embodiment and with reference to FIG. **26**, dual-polarization multi-beam transmit architecture **2600** comprises active power splitters, vector generators, and active power combiners in communication with a radiating element **2601** to form a dual polarized transmit signal from multiple input beams. In an exemplary embodiment, transmit architecture **2600** generates a dual polarized transmit signal from at least one RHCP beam and from at least one LHCP beam. More specifically, in an exemplary embodiment, transmit architecture **2600** inputs include N RHCP beams and M LHCP beams.

**[0171]** Each beam, whether right-hand polarized or left-hand polarized, is added to the dual polarized output signal using a similar component configuration. In an exemplary embodiment, an active power splitter **2610** receives a beam having either right-hand or left-hand circular polarization and divides the beam into two divided signals. A first vector generator **2620** receives one of the two divided signals at the input. A second vector generator **2621** receives the other of the two divided signals at the input. First vector generator **2620** is configured to adjust at least one of the phase and amplitude of the divided signal for beam steering. Second vector generator **2621** is configured to adjust at least one of

the phase and amplitude of the divided signal for polarization tracking. In other embodiments, first vector generator **2620** performs polarization tracking and second vector generator **2621** performs beam steering.

[0172] Furthermore, in an exemplary embodiment first vector generator **2620** generates a vertically polarized signal that is combined with other vertically polarized signals in a first active power combiner **2630**. The combined output signal of first active power combiner **2630** is transmitted to radiating element **2601** as a vertical polarization signal. Moreover, in the exemplary embodiment second vector generator **2621** generates a horizontally polarized signal that is combined with other horizontally polarized signals in a second active power combiner **2631**. The combined output signal of second active power combiner **2631** is transmitted to radiating element **2601** as a horizontal polarization signal. Active power combiner **2630** may be understood to comprise multiple active power combiners, and second active power combiner **2631** may be understood to comprise the same number of multiple active power combiners. In an exemplary embodiment, transmit architecture **2600** is configured to provide complete polarization flexibility on a beam by beam basis. However, transmit architecture **2600** uses  $2*(M+N)$  vector generators to accomplish this complete flexibility.

[0173] In a circular polarization embodiment, fewer components are used in comparison to a complete polarization embodiment because circular polarization only needs  $\pm 90^\circ$  polarization tracking. Therefore, in an exemplary embodiment and with reference to FIG. 27, a dual-polarization multi-beam transmit architecture **2700** with circular polarization comprises vector generators and active power combiners in communication with a radiating element **2701** to form a dual polarized transmit signal from multiple input beams. In an exemplary embodiment, transmit architecture **2700** generates a dual polarized transmit signal from at least one RHCP beam and from at least one LHCP beam. As with the complete polarization embodiment, transmit architecture **2700** inputs include N RHCP beams and M LHCP beams.

[0174] Each beam, whether right-hand polarized or left-hand polarized, is added to the dual polarized output signal using a similar component configuration. In an exemplary embodiment, a vector generator **2720** receives an input beam. Vector generator **2720** is configured to adjust at least one of the phase and amplitude of the input beam. The output signal of vector generator **2720** is communicated to a QAF **2740**. In an exemplary embodiment, QAF **2740** divides output signal into a vertical signal and a horizontal signal while injecting a nominally  $90^\circ$  relative phase shift between the two signals to generate vertical and horizontal polarizations.

[0175] Furthermore, in an exemplary embodiment QAF **2740** generates a vertically polarized signal that is combined with other vertically polarized signals in a first active power combiner **2730**. The combined output signal of first active power combiner **2730** is transmitted to radiating element **2701** as a vertical polarization signal. Moreover, in the exemplary embodiment QAF **2740** also generates a horizontally polarized signal that is combined with other horizontally polarized signals in a second active power combiner **2731**. The combined output signal of second active power combiner **2731** is transmitted to radiating element **2701** as a horizontal polarization signal. Active power combiner **2730** may be understood to comprise multiple active power com-

biners, and second active power combiner **2731** may be understood to comprise the same number of multiple active power combiners.

[0176] In an exemplary embodiment, transmit architecture **2700** adjusts for the input beam having either RHCP or LHCP by alternating which output signal of QAF **2740** is communicated to each active power combiner. For example, and as illustrated in FIG. 27, for a RHCP beam, a vertical polarized signal is connected to an I vector output of QAF **2740**. In contrast, for a LHCP, a vertical polarized signal is connected to a Q vector output of QAF **2740**. In an exemplary embodiment, transmit architecture **2700** forms a dual polarized output signal from circular polarized input beams using  $(M+N)$  vector generators.

[0177] Although FIGS. 24-27 illustrate a one dimensional phased array, a two dimensional phased array is also contemplated and would be understood by one skilled in the art in light of the disclosure.

[0178] Slant Polarization:

[0179] Moreover, in accordance with various embodiments, a phased array antenna may communicate one or more signals using slant linear polarization, which may be referred to as  $\pm 45^\circ$  degree polarization. Slant linear polarization can be generated through simultaneous excitation of physically orthogonal feeds of an antenna. Slant linear polarization can be generated by dividing RF power equally between the two orthogonal feeds while selecting a desired phase relationship between the two feeds. In order to generate a horizontal polarization, the input ports are driven in phase and the two feeds are summed. In order to generate a vertical polarization, the two ports are driven 180 degrees out of phase and the two feeds are summed.

[0180] In an exemplary embodiment and with reference to FIG. 30, a phased array antenna **3000** is configured to receive a signal with slant linear polarization. Phased array antenna **3000** comprises an active power combiner **3010**, a first active vector generator **3020**, a second active vector generator **3021**, a first DAC **3030**, and a second DAC **3031**. Phased array antenna **3000** is a basic receive embodiment with active vector generators **3020**, **3021** receiving individual polarized signals from radiating element **3001** as input signals. The individual polarized signals may be a first feed signal oriented at  $+45^\circ$  and a second feed signal oriented at  $-45^\circ$ . In accordance with various embodiments, a horizontal polarized signal can be generated by maintaining the first feed signal in phase when passing through first active vector generator **3020** and maintaining the second feed signal in phase when passing through second active vector generator **3021**. The first and second feed signals are summed at active power combiner **3010** to form the horizontal polarized signal. Similarly, and in accordance with various embodiments, a vertical polarized signal can be generated by maintaining the first feed signal in phase when passing through first active vector generator **3020** and injecting a  $180^\circ$  phase difference in the second feed signal at the second active vector generator **3021**. The first feed signal and the inverted second feed signal are summed at active power combiner **3010** to form the vertical polarized signal.

[0181] With reference to DACs **3030**, **3031** of FIG. 31, the active vector generators **3020**, **3021** are controlled in part by respective DACs **3030**, **3031**. In an exemplary embodiment, a 4-bit DAC is used but any number of bits may be used. In various embodiments, reconfiguration of DACs **3030**, **3031** allows the number of phase bits to be digitally con-

trolled after phased array antenna 3000 is fabricated if adequate DAC resolution and AGC dynamic range exists. In an exemplary embodiment with adequate DAC resolution and AGC dynamic range, any desired vector phase and amplitude can be produced with selectable fine quantization steps using digital control. In another exemplary embodiment, reconfiguration of DACs 3030, 3031 can be made after phased array antenna 3100 is fabricated in order to facilitate adjustment of the signal phases.

**[0182]** In an exemplary embodiment and with reference to FIG. 31, a phased array antenna 3100 is configured to receive an input signal and transmit as slant linear polarized signal. Phased array antenna 3100 comprises an active power splitter 3110, a first active vector generator 3120, a second active vector generator 3121, a first DAC 3130, and a second DAC 3131. Phased array antenna 3100 is a basic transmit embodiment with the two active vector generator output signals energizing a radiating element 3101 in both orthogonal feeds. In accordance with various embodiments, a transmit beam input signal can be transmitted using horizontal slant polarization by splitting, at active power splitter 3110, an input signal into a first feed signal and a second feed signal. The first feed signal can be communicated with a phase angle of “ $\Theta$ ” in response to passing through first active vector generator 3120 and the second feed signal can be communicated with a phase angle of “ $\Theta$ ” in response to passing through second active vector generator 3121. The first feed signal is transmitted to one of the orthogonal feeds of radiating element 3101 and the second feed signal is transmitted to the other orthogonal feed of radiating element 3101. Similarly, in accordance with various embodiments, a transmit beam input signal can be transmitted using vertical slant polarization by splitting, at active power splitter 3110, an input signal into a first feed signal and a second feed signal. The first feed signal can be communicated with a phase angle of “ $\Theta$ ” in response to passing through first active vector generator 3120 and the second feed signal can be communicated with a phase angle of “ $\Theta \pm 180^\circ$ ” in response to passing through second active vector generator 3121. The first feed signal is transmitted to one of the orthogonal feeds of radiating element 3101 and the second feed signal is transmitted to the other orthogonal feed of radiating element 3101.

**[0183]** With reference to DACs 3130, 3131 of FIG. 31, the active vector generators 3120, 3121 are controlled in part by respective DACs 3130, 3131. In an exemplary embodiment, a 4-bit DAC is used but any number of bits may be used. In various embodiments, reconfiguration of DACs 3130, 3131 allows the number of phase bits to be digitally controlled after phased array antenna 3100 is fabricated if adequate DAC resolution and AGC dynamic range exists. In an exemplary embodiment with adequate DAC resolution and AGC dynamic range, any desired vector phase and amplitude can be produced with selectable fine quantization steps using digital control. In another exemplary embodiment, reconfiguration of DACs 3130, 3131 can be made after phased array antenna 3100 is fabricated in order to facilitate adjustment of the signal phases.

**[0184]** In accordance with an exemplary embodiment and with reference to FIG. 32, a slant-polarization, dual-beam receive phased array antenna 3200 comprises a first active power splitter 3210 and a second active power splitter 3211 in communication with a radiating element 3201. Phased array antenna 3200 further comprises a first active vector

generator 3220 in parallel with a second active vector generator 3221, which are both in communication with first active power splitter 3210. Moreover, phased array antenna 3200 further comprises a third active vector generator 3222 in parallel with a fourth active vector generator 3223, which are both in communication with second active power splitter 3211. In an exemplary embodiment, a digital control (not shown) communicates polarization and beam steering commands to active vector generators 3220, 3221, 3222, 3223. Additionally, phased array antenna 3200 further comprises a first active power combiner 3240 and a second active power combiner 3241. First active power combiner 3240 is in communication with first active vector generator 3220 and third active vector generator 3222. Second active power combiner 3241 is in communication with second active vector generator 3221 and fourth active vector generator 3223.

**[0185]** In an exemplary embodiment, a signal is received at radiating element 3201 having a  $+45^\circ$  polarization and a  $-45^\circ$  polarization. The  $+45^\circ$  polarized signal is communicated to first active power splitter 3210 and the  $-45^\circ$  polarized signal is communicated to second active power splitter 3211. In an exemplary embodiment, first active power splitter 3210 is configured to divide the  $+45^\circ$  polarized signal into two signals, and second active power splitter 3211 is configured to divide the  $-45^\circ$  polarized signal into two signals.

**[0186]** In an exemplary embodiment, a first receive beam output is formed using first active vector generator 3220, third active vector generator 3222, and first active power combiner 3240. The first active vector generator 3220 receives a  $+45^\circ$  signal from first active power splitter 3210 and third active vector generator 3222 receives a  $-45^\circ$  signal from second active power splitter 3211. In accordance with various exemplary embodiments, first active power combiner 3240 receives two feed signals; one feed signal from first active vector generator 3220 and another feed signal from third active vector generator 3222, and forms the first receive beam output. The first feed signal of first receive beam output can be communicated with a phase angle of “ $\Theta$ ” in response to passing through first active vector generator 3220 and the second feed signal of the first receive beam output can be communicated with a phase angle of “ $\Theta$ ” or “ $\Theta \pm 180^\circ$ ” in response to passing through third active vector generator 3222. First active power combiner 3240 combines the two feed signals into the first receive beam output. The first receive beam output may be vertical or horizontal polarization, depending on the parameters of third active vector generator 3222. For example, third active vector generator 3222 communicating a “ $\Theta$ ” phase angle signal, if combined with a “ $\Theta$ ” phase angle signal from first active vector generator 3220, results in first active power combiner 3240 generating a horizontal polarized first receive beam output. Alternatively, third active vector generator 3222 communicating a “ $\Theta + 180^\circ$ ” phase shifted signal, if combined with a “ $\Theta$ ” phase angle signal from first active vector generator 3220, results in first active power combiner 3240 generating a vertical polarized first receive beam output.

**[0187]** Likewise, in an exemplary embodiment, a second receive beam output is formed using second active vector generator 3221, fourth active vector generator 3223, and second active power combiner 3241. The second active vector generator 3221 receives a  $+45^\circ$  signal from first

active power splitter **3210** and fourth active vector generator **3223** receives a  $-45^\circ$  signal from second active power splitter **3211**. In accordance with an exemplary embodiment, active power combiner **3241** receives two feed signals, one feed signal from second active vector generator **3221** and another feed signal from fourth active vector generator **3223**. The first feed signal of the second receive beam output can be communicated with a phase angle of “ $\Theta$ ” in response to passing through second active vector generator **3221** and the second feed signal of the second receive beam output can be communicated with a phase angle of “ $\Theta$ ” or “ $\Theta \pm 180^\circ$ ” in response to passing through fourth active vector generator **3223**. Second active power combiner **3241** combines the two feed signals into the second receive beam output. The second receive beam output may be vertical or horizontal polarization, depending on the parameters of fourth active vector generator **3223**. For example, fourth active vector generator **3223** communicating a “ $\Theta$ ” phase angle signal, if combined with a “ $\Theta$ ” phase angle signal from second active vector generator **3221**, results in second active power combiner **3241** generating a horizontal polarized second receive beam output. Alternatively, fourth active vector generator **3223** communicating a “ $\Theta + 180^\circ$ ” phase angle signal, if combined with a “ $\Theta$ ” phase angle signal from second active vector generator **3221**, results in second active power combiner **3241** generating a vertical polarized second receive beam output.

[0188] In accordance with an exemplary embodiment and with reference to FIG. 33, a slant-polarization, dual-beam transmit phased array antenna **3300** comprises a first active power splitter **3310** and a second active power splitter **3311**. Phased array antenna **3300** further comprises a first active vector generator **3320** in parallel with a second active vector generator **3321**, where first active vector generator **3320** is in communication with first active power splitter **3310**, and where second active vector generator **3321** is in communication with second active power splitter **3311**. Moreover, phased array antenna **3300** further comprises a third active vector generator **3322** in parallel with a fourth active vector generator **3323**, where third active vector generator **3322** is in communication with first active power splitter **3310**, and where fourth active vector generator **3323** is in communication with second active power splitter **3311**. Additionally, phased array antenna **3300** further comprises a first active power combiner **3340** and a second active power combiner **3341**. First active power combiner **3340** is in communication with first active vector generator **3320** and second active vector generator **3321**. Second active power combiner **3341** is in communication with third active vector generator **3322** and fourth active vector generator **3323**. In an exemplary embodiment, a digital control (not shown) communicates polarization and beam steering commands to active vector generators **3320**, **3321**, **3322**, **3323**. Additionally, first active power combiner **3340** and second active power combiner **3341** are each in communication with a radiating element **3301**.

[0189] In an exemplary embodiment, a first transmit beam input is received at first active power splitter **3310** and a second transmit beam input is received at second active power splitter **3311**. The first and second transmit beams are combined at first and second active power combiners **3340**, **3341**, and transmitted as slant polarized signals.

[0190] In various embodiments, first active power splitter **3310** is configured to divide the first transmit beam input

into two feed signals. The first feed signal of first transmit beam input can be communicated with a phase angle of “ $\Theta$ ” in response to passing through first active vector generator **3320** and the second feed signal of the first transmit beam input can be communicated with a phase angle of “ $\Theta$ ” or “ $\Theta \pm 180^\circ$ ” in response to passing through third active vector generator **3322**. The first transmit beam input may be vertical or horizontal polarized, which is adjusted for depending on the parameters of third active vector generator **3322**. For example, third active vector generator **3322** communicating a “ $\Theta$ ” phase angle signal, if combined with a “ $\Theta$ ” phase angle signal from first active vector generator **3320**, results in the first transmit beam input having a horizontal polarization being transmitted as a slant polarized transmit beam output. Alternatively, third active vector generator **3322** communicating a “ $\Theta + 180^\circ$ ” phase shifted signal, if combined with a “ $\Theta$ ” phase angle signal from first active vector generator **3320**, results in the first transmit beam input having a vertical polarization being transmitted as a slant polarized transmit beam output.

[0191] In various embodiments, second active power splitter **3311** is configured to divide the second transmit beam input into two feed signals. The first feed signal of second transmit beam input can be communicated with a phase angle of “ $\Theta$ ” in response to passing through second active vector generator **3321** and the second feed signal of the second transmit beam input can be communicated with a phase angle of “ $\Theta$ ” or “ $\Theta \pm 180^\circ$ ” in response to passing through fourth active vector generator **3323**. The second transmit beam input may be vertical or horizontal polarized, which is adjusted for depending on the parameters of fourth active vector generator **3323**. For example, fourth active vector generator **3323** communicating a “ $\Theta$ ” phase angle signal, if combined with a “ $\Theta$ ” phase angle signal from second active vector generator **3321**, results in the second transmit beam input having a horizontal polarization being transmitted as a slant polarized transmit beam output. Alternatively, fourth active vector generator **3323** communicating a “ $\Theta + 180^\circ$ ” phase shifted signal, if combined with a “ $\Theta$ ” phase angle signal from second active vector generator **3321**, results in the second transmit beam input having a vertical polarization being transmitted as a slant polarized transmit beam output.

[0192] In accordance with an exemplary embodiment, first active power combiner **3340** receives two intermediate feed signals; one intermediate feed signal from first active vector generator **3320** and another intermediate feed signal from second active vector generator **3321**, and forms a  $+45^\circ$  slant polarized transmit beam output. Likewise, in accordance with various embodiments, second active power combiner **3341** receives two intermediate feed signals; one intermediate feed signal from third active vector generator **3322** and another intermediate feed signal from fourth active vector generator **3323**, and forms a  $-45^\circ$  slant polarized transmit beam output.

[0193] Receive Architecture:

[0194] In accordance with an exemplary embodiment and with reference to FIG. 34, slant-polarization multi-beam receive architecture **3400** comprises active power splitters, active vector generators, and active power combiners in communication with a radiating element **3401** to form multiple beams. In an exemplary embodiment, receive architecture **3400** forms either a horizontal polarized beam or a

vertical polarized beam. More specifically, in an exemplary embodiment, receive architecture 3400 forms N horizontal and/or vertical beams.

[0195] Each beam, whether horizontal polarized or vertical polarized, is formed using a similar component configuration. In an exemplary embodiment, two signals are received at radiating element 3401 having a +45° polarization and a -45° polarization, respectively. The +45° polarized signal is communicated to a first active power splitter 3410 and the -45° polarized signal is communicated to a second active power splitter 3411. In an exemplary embodiment, active power splitter 3410 is configured to divide the +45° polarized signal into at least two signals, and active power splitter 3411 is configured to divide the -45° polarized signal into at least two signals. Moreover, first active power splitter 3410 may be understood to comprise multiple active power splitters, and second active power splitter 3411 may be understood to comprise the same number of multiple active power splitters. In an exemplary embodiment, active power splitters 3410, 3411 individually divide the signal into two or more signals, such that the +45° polarized signal and -45° polarized signal are divided into a certain number of signals. In other words, the +45° polarized signal and -45° polarized signal are each divided into N signals.

[0196] In an exemplary embodiment, each beam is formed using a first active vector generator 3420, a second active vector generator 3421, and an active power combiner 3430. The first active vector generator 3420 receives the +45° polarized signal from first active power splitter 3410. Furthermore, second active vector generator 3421 receives the -45° polarized signal from second active power splitter 3411. In an exemplary embodiment, a digital control (not shown) communicates polarization and beam steering commands to first active vector generator 3420 and second active vector generator 3421. In accordance with an exemplary embodiment, active power combiner 3430 receives two output signals, one signal from first active vector generator 3420 and another signal from second active vector generator 3421. Active power combiner 3430 combines the two signals into an output beam. The output beam can have horizontal or vertical polarization, depending on the parameters of active vector generators 3420, 3421. For example, second active vector generator 3421 communicating a signal with phase  $\Theta$ , if combined with a signal with phase  $\Theta$  from first active vector generator 3420, results in first active power combiner 3430 generating a horizontal polarized first output beam. Alternatively, second active vector generator 3421 communicating a  $\Theta \pm 180^\circ$  phase shifted signal, if combined with a signal with phase  $\Theta$  from first active vector generator 3420, results in first active power combiner 3430 generating a vertical polarized first output beam. In an exemplary embodiment, receive architecture 3400 is configured to provide complete polarization flexibility between horizontal and vertical polarization on a beam by beam basis. Receive architecture 3400 uses  $2 \cdot N$  active vector generators to accomplish this flexibility. In accordance with the various embodiments, receive architecture 3400 can include N active power combiners, N first active vector generators, and N second active vector generators. The configuration forms N receive beam outputs, with each beam output capable of switching between horizontal and vertical polarization by controlling the active vector generator phase shift to be either " $\Theta$ " or " $\Theta \pm 180^\circ$ ."

[0197] Transmit Architecture:

[0198] In accordance with an exemplary embodiment and with reference to FIG. 35, slant-polarization multi-beam transmit architecture 3500 comprises active power splitters, active vector generators, and active power combiners in communication with a radiating element 3501 having slant slots to form a polarized transmit signal from multiple input beams. In an exemplary embodiment, transmit architecture 3500 generates a slant-polarized transmit signal from at least one of a horizontal polarized beam or a vertical polarized beam. More specifically, in an exemplary embodiment, transmit architecture 3500 inputs include N beams, which may individually be one of horizontal or vertical beams.

[0199] Each input beam, whether horizontal polarized or vertical polarized, is added to the slant polarized output signal using a similar component configuration. In an exemplary embodiment, an active power splitter 3510 receives an input beam having either horizontal or vertical polarization and divides the input beam into two divided signals. A first active vector generator 3520 receives one of the two divided signals at the input. A second active vector generator 3521 receives the other of the two divided signals at the input. In an exemplary embodiment, a digital control (not shown) communicates polarization and beam steering commands to first active vector generator 3520 and second active vector generator 3521.

[0200] Furthermore, in an exemplary embodiment, first active vector generator 3520 communicates the one of the two divided signals with a phase of " $\Theta$ " to a first active power combiner 3530. In various embodiments, first active power combiner 3530 is configured to receive signals with a phase of " $\Theta$ " from one or more active vector generators 3520. The combined output signal of first active power combiner 3530 is transmitted to a +45° slant slot of radiating element 3501.

[0201] Moreover, in the exemplary embodiment, second active vector generator 3521 generates a polarized signal with a phase of either " $\Theta$ " or " $\Theta \pm 180^\circ$ ," depending on the polarization of each input beam. In response to the input beam having horizontal polarization, second active vector generator 3521 can be configured to communicate an output signal with phase of " $\Theta$ ." In response to the input beam having vertical polarization, second active vector generator 3521 can be configured to communicate an output signal with phase of " $\Theta \pm 180^\circ$ ." The slant polarized signal generated by second active vector generator 3521 can be combined with other slant polarized signals in a second active power combiner 3531. The combined output signal of second active power combiner 3531 is transmitted to radiating element 3501 as a -45° slant polarized signal. Active power combiner 3530 may be understood to comprise multiple active power combiners, and second active power combiner 3531 may be understood to comprise the same number of multiple active power combiners. In an exemplary embodiment, transmit architecture 3500 is configured to provide complete polarization flexibility between horizontal and vertical polarization on a beam by beam basis. Transmit architecture 3500 uses  $2 \cdot N$  active vector generators to accomplish this complete flexibility. In accordance with the various embodiments, transmit architecture 3500 can include N active power splitters, N first active vector generators, and N second active vector generators. The configuration transmits N transmit beam inputs, with each beam input being either horizontal and vertical polarization and



forming a combined output beam by controlling the active vector generator phase shift to be either “ $\Theta$ ” or “ $\Theta \pm 180^\circ$ .”

[0202] Several of the phased array antenna embodiments disclosed herein relate to communicating one or more signals in various polarizations, such as linear, circular, elliptical, or slant polarization. Furthermore, in various exemplary embodiments, a phased array antenna can be configured to communicate two or more beams having independent polarization.

[0203] In accordance with an exemplary embodiment and with reference to FIG. 36, an independent polarization, dual-beam receive phased array antenna 3600 comprises a first active power splitter 3610 and a second active power splitter 3611 in communication with a radiating element 3601. Phased array antenna 3600 further comprises a first active vector generator 3620 in parallel with a second active vector generator 3621, which are both in communication with first active power splitter 3610. Moreover, phased array antenna 3600 further comprises a third active vector generator 3622 in parallel with a fourth active vector generator 3623, which are both in communication with second active power splitter 3611. In an exemplary embodiment, a digital control (not shown) communicates polarization and beam steering commands to active vector generators 3620, 3621, 3622, 3623. Additionally, phased array antenna 3600 further comprises a first active power combiner 3640 and a second active power combiner 3641. First active power combiner 3640 is in communication with first active vector generator 3620 and third active vector generator 3622. Second active power combiner 3641 is in communication with second active vector generator 3621 and fourth active vector generator 3623.

[0204] In an exemplary embodiment, a signal can be received at radiating element 3601 having a horizontal feed and having a vertical feed. The horizontal feed signal can be communicated to first active power splitter 3610 and the vertical feed signal can be communicated to second active power splitter 3611. In an exemplary embodiment, first active power splitter 3610 can be configured to divide the horizontal feed signal into two intermediate horizontal signals, and second active power splitter 3611 can be configured to divide the vertical feed signal into two intermediate vertical signals.

[0205] In an exemplary embodiment, a first receive beam output is formed using first active vector generator 3620, third active vector generator 3622, and first active power combiner 3640. The first active vector generator 3620 receives one of the intermediate horizontal signals from first active power splitter 3610 and third active vector generator 3622 receives one of the intermediate vertical signals from second active power splitter 3611. In various embodiments, first active vector generator 3620 communicates a horizontal beam signal having a beam steering angle of “ $\Theta$ ” to first active power combiner 3640. Further, third active vector generator 3622 communicates a vertical beam signal to first active power combiner 3640. The beam steering angle of the vertical beam signal is set based on the desired polarization of the first receive beam output. In accordance with an exemplary embodiment, first active power combiner 3640 receives two feed signals, a first feed signal from first active vector generator 3620 and a second feed signal from third active vector generator 3622. The first feed signal of first receive beam output can be communicated with a phase angle of “ $\Theta$ ” in response to passing through first active

vector generator 3620 and the second feed signal of the first receive beam output can be communicated with a phase angle of “ $\Theta$ ,” “ $\Theta + 90^\circ$ ,” “ $\Theta - 90^\circ$ ,” or “ $\Theta \pm 180^\circ$ ” in response to passing through third active vector generator 3622. First active power combiner 3640 combines the two feed signals into the first receive beam output. The first receive beam output can be any polarization type, including linear, circular, elliptical, or slant polarization, depending on the parameters of first active vector generator 3620 and the parameters of third active vector generator 3622. For example, third active vector generator 3622 communicating a “ $\Theta$ ” phase angle signal, if combined with a “ $\Theta$ ” phase angle signal from first active vector generator 3620, results in first active power combiner 3640 generating a horizontal slant polarized first receive beam output. Additionally, third active vector generator 3622 communicating a “ $\Theta + 90^\circ$ ” phase angle signal, if combined with a “ $\Theta$ ” phase angle signal from first active vector generator 3620, results in first active power combiner 3640 generating a right hand circular polarized (RHCP) first receive beam output. Further, third active vector generator 3622 communicating a “ $\Theta - 90^\circ$ ” phase angle signal, if combined with a “ $\Theta$ ” phase angle signal from first active vector generator 3620, results in first active power combiner 3640 generating a left hand circular polarized (LHCP) first receive beam output. Moreover, third active vector generator 3622 communicating a “ $\Theta \pm 180^\circ$ ” phase shifted signal, if combined with a “ $\Theta$ ” phase angle signal from first active vector generator 3620, results in first active power combiner 3640 generating a vertical slant polarized first receive beam output.

[0206] Likewise, in an exemplary embodiment, a second receive beam output is formed using second active vector generator 3621, fourth active vector generator 3623, and second active power combiner 3641. The second active vector generator 3621 receives the other intermediate horizontal signal from first active power splitter 3610 and fourth active vector generator 3623 receives the other intermediate vertical signal from second active power splitter 3611.

[0207] In various embodiments, second active vector generator 3621 communicates a horizontal beam signal having a beam steering angle of “ $\Theta$ ” to second active power combiner 3641. Further, fourth active vector generator 3623 communicates a vertical beam signal to second active power combiner 3641. The beam steering angle of the horizontal beam signal is set based on the desired polarization of the second output beam. In accordance with various exemplary embodiments, second active power combiner 3641 receives two feed signals, a first feed signal from second active vector generator 3621 and a second feed signal from fourth active vector generator 3623. The first feed signal of second receive beam output can be communicated with a phase angle of “ $\Theta$ ” in response to passing through second active vector generator 3621 and the second feed signal of the second receive beam output can be communicated with a phase angle of “ $\Theta$ ,” “ $\Theta + 90^\circ$ ,” “ $\Theta - 90^\circ$ ,” or “ $\Theta \pm 180^\circ$ ” in response to passing through fourth active vector generator 3623. Second active power combiner 3641 combines the two feed signals into the second receive beam output. The second receive beam output can be any polarization type, including linear, circular, elliptical, or slant polarization, depending on the parameters of second active vector generator 3621 and the parameters of fourth active vector generator 3623. For example: fourth active vector generator 3623 communicating a “ $\Theta$ ” phase angle signal, if combined

with a “ $\Theta$ ” phase angle signal from second active vector generator 3621, results in second active power combiner 3641 generating a horizontal slant polarized first receive beam output. Additionally, fourth active vector generator 3623 communicating a “ $\Theta+90^\circ$ ” phase angle signal, if combined with a “ $\Theta$ ” phase angle signal from second active vector generator 3621, results in second active power combiner 3641 generating a right hand circular polarized (RHCP) first receive beam output. Further, fourth active vector generator 3623 communicating a “ $\Theta-90^\circ$ ” phase angle signal, if combined with a “ $\Theta$ ” phase angle signal from second active vector generator 3621, results in second active power combiner 3641 generating a left hand circular polarized (LHCP) first receive beam output. Moreover, fourth active vector generator 3623 communicating a “ $\Theta\pm 180^\circ$ ” phase shifted signal, if combined with a “ $\Theta$ ” phase angle signal from second active vector generator 3621, results in second active power combiner 3641 generating a vertical slant polarized first receive beam output.

[0208] In accordance with an exemplary embodiment and with reference to FIG. 37, an independent-polarization, dual-beam transmit phased array antenna 3700 comprises a first active power combiner 3740 and a second active power combiner 3741, each in communication with a radiating element 3701. Phased array antenna 3700 further comprises a first active vector generator 3720 in parallel with a second active vector generator 3721, which are both in communication with first active power combiner 3740. Moreover, phased array antenna 3700 further comprises a third active vector generator 3722 in parallel with a fourth active vector generator 3723, which are both in communication with second active power combiner 3741. In an exemplary embodiment, a digital control (not shown) communicates polarization and beam steering commands to active vector generators 3720, 3721, 3722, 3723. Additionally, phased array antenna 3700 further comprises a first active power splitter 3710 and a second active power splitter 3711. First active power splitter 3710 is in communication with first active vector generator 3720 and third active vector generator 3722. Similarly, second active power splitter 3711 is in communication with second active vector generator 3721 and fourth active vector generator 3723.

[0209] In an exemplary embodiment, a first transmit beam input is received at first active power splitter 3710 and a second transmit beam input is received at second active power splitter 3711. The first and second transmit beam inputs are combined at first and second active power combiners 3740, 3741, and transmitted as independently polarized signals. In an exemplary embodiment, first active power splitter 3710 is configured to divide the first transmit beam input into a pair of first transmit beam intermediate signals, and second active power splitter 3711 is configured to divide the second transmit beam input into a pair of second transmit intermediate signals.

[0210] In various embodiments, first active power splitter 3710 is configured to divide the first transmit beam input into two feed signals. The first feed signal of first transmit beam input can be communicated with a phase angle of “ $\Theta$ ” in response to passing through first active vector generator 3720 and the second feed signal of the first transmit beam input can be communicated with a phase angle of “ $\Theta$ ,” “ $\Theta+90^\circ$ ,” “ $\Theta-90^\circ$ ,” or “ $\Theta\pm 180^\circ$ ” in response to passing through third active vector generator 3722. The first transmit beam can be any polarization type, including linear, circular,

elliptical, or slant polarization, depending on the parameters of first active vector generator 3720 and the parameters of third active vector generator 3722. For example, third active vector generator 3722 communicating a “ $\Theta$ ” phase angle signal, if combined with a “ $\Theta$ ” phase angle signal from first active vector generator 3720, results in the first transmit beam being transmitted as a horizontal slant polarized transmit beam output. Additionally, third active vector generator 3722 communicating a “ $\Theta+90^\circ$ ” phase angle signal, if combined with a “ $\Theta$ ” phase angle signal from first active vector generator 3720, results in the first transmit beam being transmitted as a RHCP transmit beam output. Further, third active vector generator 3722 communicating a “ $\Theta-90^\circ$ ” phase angle signal, if combined with a “ $\Theta$ ” phase angle signal from first active vector generator 3720, results in the first transmit beam being transmitted as a LHCP transmit beam output. Moreover, third active vector generator 3722 communicating a “ $\Theta+180^\circ$ ” phase shifted signal, if combined with a “ $\Theta$ ” phase angle signal from first active vector generator 3720, results in the first transmit beam input being transmitted as a vertical slant polarized transmit beam output.

[0211] Similarly, in various embodiments, second active power splitter 3711 is configured to divide the second transmit beam input into two feed signals. The first feed signal of second transmit beam input can be communicated with a phase angle of “ $\Theta$ ” in response to passing through second active vector generator 3721 and the second feed signal of the second transmit beam input can be communicated with a phase angle of “ $\Theta$ ,” “ $\Theta+90^\circ$ ,” “ $\Theta-90^\circ$ ,” or “ $\Theta\pm 180^\circ$ ” in response to passing through fourth active vector generator 3723. The second transmit beam can be any polarization type, including linear, circular, elliptical, or slant polarization, depending on the parameters of second active vector generator 3721 and the parameters of fourth active vector generator 3723. For example, fourth active vector generator 3723 communicating a “ $\Theta$ ” phase angle signal, if combined with a “ $\Theta$ ” phase angle signal from second active vector generator 3721, results in the second transmit beam being transmitted as a horizontal slant polarized transmit beam output. Additionally, fourth active vector generator 3723 communicating a “ $\Theta+90^\circ$ ” phase angle signal, if combined with a “ $\Theta$ ” phase angle signal from second active vector generator 3721, results in the second transmit beam being transmitted as a RHCP transmit beam output. Further, fourth active vector generator 3723 communicating a “ $\Theta-90^\circ$ ” phase angle signal, if combined with a “ $\Theta$ ” phase angle signal from second active vector generator 3721, results in the second transmit beam being transmitted as a LHCP transmit beam output. Moreover, fourth active vector generator 3723 communicating a “ $\Theta+180^\circ$ ” phase shifted signal, if combined with a “ $\Theta$ ” phase angle signal from second active vector generator 3721, results in the second transmit beam input being transmitted as a vertical slant polarized transmit beam output.

[0212] In accordance with an exemplary embodiment and with reference to FIG. 38, independent polarization multi-beam receive architecture 3800 comprises active power splitters, active vector generators, active power combiners, and a radiating element 3801. These elements are configured to form multiple output beams from the signals received at radiating element 3801. In an exemplary embodiment, receive architecture 3800 forms independent polarized receive output beams. More specifically, in an exemplary

embodiment, receive architecture **3800** forms N independent polarized receive output beams.

[0213] Each receive output beam, regardless of the polarization, is formed using a similar component configuration. In an exemplary embodiment, a signal is received at radiating element **3801** having a vertical beam signal component and a horizontal beam signal component. The vertical beam signal is communicated to a first active power splitter **3810** and the horizontal beam signal is communicated to a second active power splitter **3811**. In an exemplary embodiment, first active power splitter **3810** is configured to divide the vertical beam signal into at least two signals, and second active power splitter **3811** is configured to divide the horizontal beam signal into at least two signals. Moreover, first active power splitter **3810** may be understood to comprise multiple active power splitters, and second active power splitter **3811** may be understood to comprise the same number of multiple active power splitters. In an exemplary embodiment, active power splitters **3810**, **3811** individually divide the signal into two or more signals, such that the vertical beam signal and the horizontal beam signal are divided into a certain number of signals, for example N signals.

[0214] In an exemplary embodiment, each beam is formed using a first active vector generator **3820**, a second active vector generator **3821**, and an active power combiner **3830**. The first active vector generator **3820** receives the vertical beam signal from first active power splitter **3810**. Furthermore, second active vector generator **3821** receives the horizontal beam signal from second active power splitter **3811**. In an exemplary embodiment, a digital control (not shown) communicates polarization and beam steering commands to first active vector generator **3820** and second active vector generator **3821**. In accordance with an exemplary embodiment, active power combiner **3830** receives two intermediate signals, one signal from first active vector generator **3820** and another signal from second active vector generator **3821**. Active power combiner **3830** combines the two signals into an output beam. The output beam can have any polarization, such as linear, circular, elliptical, or slant polarization, depending on the parameters of active vector generators **3820**, **3821**. For example, first active vector generator **3820** can generate a signal with a vertical beam with steering angle of “ $\Theta_a$ .” The polarization of the output beam is dependent upon the difference in the beam steering angles of the two power combiner input signals. For example, and assuming the vertical beam maintains a steering angle of “ $\Theta_a$ ”: second active vector generator **3821** producing a horizontal beam with steering angle of “ $\Theta_a$ ” generates an output beam with horizontal slant polarization; a horizontal beam with steering angle of “ $\Theta_a \pm 180^\circ$ ” generates an output beam with vertical slant polarization; a horizontal beam with steering angle of “ $\Theta_a + 90^\circ$ ” generates an output beam with right hand circular polarization (RHCP); a horizontal beam with steering angle of “ $\Theta_a - 90^\circ$ ” generates an output beam with left hand circular polarization (LHCP). In various exemplary embodiments, receive architecture **3800** is configured to provide complete polarization flexibility between horizontal and vertical polarization on a beam by beam basis. In various embodiments, receive architecture **3800** uses  $2*N$  active vector generators to accomplish this flexibility. Signal outputs of N number of first active vector generators **3820** and N number of second

active vector generators **3821** are combined at N number of active power combiners **3830** to form N receive beam outputs.

[0215] In accordance with an exemplary embodiment and with reference to FIG. **39**, independent-polarization multi-beam transmit architecture **3900** comprises active power splitters, active vector generators, and active power combiners in communication with a radiating element **3901** to form an independent polarized transmit signal from multiple transmit input beams. In an exemplary embodiment, transmit architecture **3900** generates an independent-polarized transmit signal from two or more input beams, which can have any polarization such as linear, circular, elliptical, or slant polarization. Furthermore, the transmit signal can have any polarization, such as linear, circular, elliptical, or slant polarization. More specifically, in an exemplary embodiment, transmit architecture **3900** inputs include N transmit input beams that are each individually one of horizontal or vertical input beams.

[0216] Each input beam, regardless of initial polarization and beam steering angle, is added to the independent polarized output signal using a similar component configuration. In an exemplary embodiment, an active power splitter **3910** receives an input beam and divides the input beam into two divided signals. A first active vector generator **3920** receives one of the two divided signals at the input. A second active vector generator **3921** receives the other of the two divided signals at the input. In an exemplary embodiment, a digital control (not shown) communicates polarization and beam steering commands to first active vector generator **3920** and second active vector generator **3921**.

[0217] In an exemplary embodiment, a vertical output beam is formed using two separate first active vector generators **3920** and a first active power combiner **3930**. One of the first active vector generators **3920** receives a split signal from an active power splitter **3910** and the other of the first active vector generators **3920** receives a split signal from another active power splitter **3910**.

[0218] In various embodiments, one of the first active vector generators **3920** communicates a first vertical beam signal having a beam steering angle of “ $\Theta_a$ ” to first active power combiner **3930**. Further, the other of the first active vector generators **3920** communicates a second vertical beam signal to first active power combiner **3930**. The beam steering angle of the second vertical output beam is set based on the desired polarization of the vertical output beam. In accordance with an exemplary embodiment, first active power combiner **3930** receives two input signals, the first vertical beam signal from one first active vector generator **3920** and the second vertical beam signal from another first active vector generator **3920**. First active power combiner **3930** combines the two signals into the vertical output beam. The vertical beam can be any polarization type, including linear, circular, elliptical, or slant polarization, depending on the parameters of the first active vector generators **3920**. For example, and assuming the vertical beam maintains a steering angle of “ $\Theta_a$ ”: a second vertical beam steering angle of “ $\Theta_a$ ” generates a vertical output beam with horizontal slant polarization; a second vertical beam steering angle of “ $\Theta_a \pm 180^\circ$ ” generates a vertical output beam with vertical slant polarization; a second vertical beam steering angle of “ $\Theta_a + 90^\circ$ ” generates a vertical output beam with right hand circular polarization (RHCP); a second vertical beam steer-

ing angle of “ $\Theta_a-90^\circ$ ” generates a vertical output beam with left hand circular polarization (LHCP).

[0219] Moreover, in various exemplary embodiments, a horizontal output beam is formed using two separate second active vector generators 3921 and the second active power combiner 3931. One of the second active vector generators 3921 receives a split signal from an active power splitter 3910 and the other of the second active vector generators 3921 receives a split signal from another active power splitter 3910.

[0220] In various embodiments, one of the second active vector generators 3921 communicates a first horizontal beam signal having a beam steering angle of “ $\Theta_b$ ” to second active power combiner 3931. Further, the other of the second active vector generators 3921 communicates a second horizontal beam signal to second active power combiner 3931. The beam steering angle of the second horizontal output beam is set based on the desired polarization of the horizontal output beam. In accordance with an exemplary embodiment, second active power combiner 3931 receives two input signals, the first horizontal beam signal from one of second active vector generator 3921 and the second horizontal beam signal from another second active vector generator 3921. Second active power combiner 3931 combines the two signals into the horizontal output beam. The horizontal beam can be any polarization type, including linear, circular, elliptical, or slant polarization, depending on the parameters of the second active vector generators 3921. For example: a second horizontal beam steering angle of “ $\Theta_b$ ” generates a horizontal output beam with horizontal slant polarization; a second horizontal beam steering angle of “ $\Theta_b\pm 180^\circ$ ” generates a horizontal output beam with vertical slant polarization; a second horizontal beam steering angle of “ $\Theta_b+90^\circ$ ” generates a horizontal output beam with right hand circular polarization (RHCP); a second horizontal beam steering angle of “ $\Theta_b-90^\circ$ ” generates a horizontal output beam with left hand circular polarization (LHCP).

[0221] First active power combiner 3930 may be understood to comprise multiple active power combiners, and second active power combiner 3931 may be understood to comprise the same number of multiple active power combiners. As would be known to one skilled in the art in light of the disclosure, the order of signal combination within first active power combiner 3930 and the order of signal combination within second active power combiner 3931 is irrelevant. In accordance with the various embodiments, the transmit vertical beam is a combination of the signal outputs from all the first active vector generators ( $\Sigma VG1_{1-N}$ ) and the transmit horizontal beam is a combination of the signal outputs from all the second active vector generators ( $\Sigma VG2_{1-N}$ ). In an exemplary embodiment, transmit architecture 3900 is configured to provide complete polarization flexibility on a beam by beam basis. However, transmit architecture 3900 uses  $2*N$  active vector generators to accomplish this complete flexibility. For example, FIG. 39 illustrates an embodiment with  $N=4$ .

[0222] In accordance with an exemplary embodiment, and with reference to FIG. 40, a phased array integrated circuit (“IC”) 4000 is configured as a 2-beam, 4-radiating element receiver. The phased array IC 4000 comprises a first subcircuit 4010 in communication with a first radiating element 4011, a second subcircuit 4020 in communication with a second radiating element 4021, a third subcircuit 4030 in communication with a third radiating element 4031, and a

fourth subcircuit 4040 in communication with a fourth radiating element 4041. Each subcircuit 4010, 4020, 4030, 4040 receives a pair of spatially orthogonal RF signals from the respectively coupled radiating element 4011, 4021, 4031, 4041 and generates two receive beam output signals, one for each beam to be formed. In various embodiments, the pair of spatially orthogonal RF signals received from the various radiating elements 4011, 4021, 4031, 4041 can have any polarization. In other words, the signals received from radiating element 4011 can be a first polarization, for example LHCP, and the signals received from radiating element 4021 can be a second polarization, for example vertical polarization. Furthermore, the two receive beam output signals can also have different polarizations. For example, a first receive beam output signal can be RHCP and a second receive beam output signal can be horizontal polarization. In other words, phased array integrated circuit 4000 can be configured in an exemplary embodiment to receive four input signals of any polarization on four separate radiating elements, and generate two receive output signals, with each receive output signal being controllable for independent polarization.

[0223] The structure and function of each subcircuit 4010, 4020, 4030, 4040 is substantially similar. Thus, only first subcircuit 4010 will be discussed in detail. In accordance with various embodiments, first subcircuit 4010 comprises a first active power splitter 4016 and a second active power splitter 4017 in communication with a radiating element 4011. First subcircuit 4010 further comprises a first active vector generator 4012 in parallel with a second active vector generator 4013, which are both in communication with active power splitter 4016. Moreover, first subcircuit 4010 further comprises a third active vector generator 4014 in parallel with a fourth active vector generator 4015, which are both in communication with active power splitter 4017. Additionally, first subcircuit 4010 further comprises a first active power combiner 4018 and a second active power combiner 4019. First active power combiner 4018 is in communication with first active vector generator 4012 and third active vector generator 4014. Second active power combiner 4019 is in communication with second active vector generator 4013 and fourth active vector generator 4015. In an exemplary embodiment, a digital control (not shown) communicates polarization and beam steering commands to active vector generators 4012, 4013, 4014, 4015. The operation of first subcircuit 4010 is similar to the operation of receive phased array antenna 3600, and additional understanding of first subcircuit 4010 is provided by referring to the description of receive phased array antenna 3600.

[0224] In accordance with an exemplary embodiment, a first receive beam output is generated by combining one of the two output signals from each of four subcircuits 4010, 4020, 4030, 4040. A second receive beam output is generated by combining the second of the two output signals from each of four subcircuits 4010, 4020, 4030, 4040. In an exemplary embodiment, multiple combiners are used to combine the subcircuit output signals into a first receive beam output and a second receive beam output.

[0225] In a more specific exemplary embodiment, an active combiner 4051 is configured to combine the first of the two outputs from first and second subcircuits 4010, 4020. Furthermore, an active combiner 4061 is configured to combine the second of the two outputs from first and second

subcircuits **4010**, **4020**. Also in the exemplary embodiment, an active combiner **4052** is configured to combine the first of the two outputs from third and fourth subcircuits **4030**, **4040**. An active combiner **4062** is configured to combine the second of the two outputs from third and fourth subcircuits **4030**, **4040**. At the next stage, an active combiner **4053** is configured to combine the combined outputs of active combiners **4051** and **4052** to form a first receive beam output. Furthermore, an active combiner **4063** is configured to combine the combined outputs of active combiners **4061** and **4062** to form a second receive beam output.

[0226] In addition to a 2-beam, 4-radiating element receiver, a similar structure may be configured as a 2-beam, 4-radiating element transmitter. In an exemplary embodiment, and with reference to FIG. **41**, a phased array integrated circuit **4100** is configured as a 2-beam, 4-radiating element transmitter. The phased array IC **4100** comprises a first subcircuit **4110** in communication with a first radiating element **4111**, a second subcircuit **4120** in communication with a second radiating element **4121**, a third subcircuit **4130** in communication with a third radiating element **4131**, and a fourth subcircuit **4140** in communication with a fourth radiating element **4141**. Each subcircuit **4110**, **4120**, **4130**, **4140** receives two input signals and transmits signals to the spatially orthogonal ports of the respectively coupled radiating element **4111**, **4121**, **4131**, **4141**. In various embodiments, the pair of spatially orthogonal RF signals transmitted to the various radiating elements **4111**, **4121**, **4131**, **4141** can have any polarization. In other words, the signals transmitted to radiating element **4011** can be a first polarization, for example LHCP, and the signals transmitted to radiating element **4021** can be a second polarization, for example vertical polarization. Furthermore, the two transmit beam input signals can also have different polarizations. For example, a first transmit beam input signal can be RHCP and a second transmit beam input signal can be horizontal polarization. In other words, phased array integrated circuit **4100** can be configured in an exemplary embodiment to receive two transmit beam input signals of any polarization and generate output signals on four separate radiating elements, with each output signal being controllable for independent polarization.

[0227] In accordance with an exemplary embodiment, a first transmit beam and a second transmit beam are provided to phased array IC **4100**. In an exemplary embodiment, multiple splitters are used to divide the first and second transmit beams that are communicated to each of four subcircuits **4110**, **4120**, **4130**, **4140** as input signals.

[0228] In a more specific exemplary embodiment, an active splitter **4153** is configured to divide the first transmit beam input into two separate signals that are communicated to an active splitter **4151** and an active splitter **4152**, respectively. Similarly, an active splitter **4163** is configured to divide the second transmit beam input into two separate signals that are communicated to an active splitter **4161** and an active splitter **4162**, respectively. At the next stage, active splitters **4151**, **4161** are configured to divide the communicated signals and communicate the divided signals to first subcircuit **4110** and second subcircuit **4120**. The active splitters **4152**, **4162** are configured to divide the communicated signals and communicate the divided signals to third subcircuit **4130** and fourth subcircuit **4140**.

[0229] The structure and function of each subcircuit **4110**, **4120**, **4130**, **4140** is substantially similar. Thus, only first

subcircuit **4110** will be discussed in detail. In accordance with an exemplary embodiment, first subcircuit **4110** comprises a first active power splitter **4118** and a second active power splitter **4119**, which are configured to individually receive an input signal from active splitters **4151**, **4161**, respectively. First subcircuit **4110** further comprises a first active vector generator **4114** in parallel with a second active vector generator **4115**, and also comprises a third active vector generator **4116** in parallel with a fourth active vector generator **4117**. In various embodiments, first active vector generator **4114** and third active vector generator **4116** are both in communication with first active power splitter **4118**. Moreover, second active vector generator **4115** and fourth active vector generator **4117** are both in communication with second active power splitter **4119**. Additionally, first subcircuit **4110** further comprises a first active power combiner **4112** and a second active power combiner **4113**. First active power combiner **4112** is in communication with first active vector generator **4114** and second active vector generator **4115**. Second active power combiner **4113** is in communication with third active vector generator **4116** and fourth active vector generator **4117**. In an exemplary embodiment, a digital controller (not shown) communicates polarization and beam steering commands to active vector generators **4114**, **4115**, **4116**, **4117**. The operation of first subcircuit **4110** is similar to the operation of transmit phased array antenna **3700**, and additional understanding of first subcircuit **4110** is provided by referring to the description of receive phased array antenna **3700**.

[0230] In an exemplary embodiment, a first transmit beam input is received at first active power splitter **4118** from active splitter **4151** and a second transmit input beam is received at second active power splitter **4119** from active splitter **4161**. In an exemplary embodiment, first active power splitter **4118** is configured to divide the first transmit beam input into two signals, and second active power splitter **4119** is configured to divide the second transmit input beam into two signals.

[0231] In an exemplary embodiment and with reference to FIG. **42A**, a phased array integrated circuit **4200** is configured as a 4-beam, 4-radiating element receiver. The phased array IC **4200** comprises a first subcircuit **4210** in communication with a first radiating element **4211**, a second subcircuit **4220** in communication with a second radiating element **4221**, a third subcircuit **4230** in communication with a third radiating element **4231**, and a fourth subcircuit **4240** in communication with a fourth radiating element **4241**. Each subcircuit **4210**, **4220**, **4230**, **4240** receives a pair of spatially orthogonal RF signals from the respectively coupled radiating element **4211**, **4221**, **4231**, **4241** and generates four output signals, one for each beam to be formed.

[0232] The structure and function of each subcircuit **4210**, **4220**, **4230**, **4240** is substantially similar. Thus, only first subcircuit **4210** will be discussed in detail. In accordance with an exemplary embodiment and with reference to FIG. **42B**, first subcircuit **4210**, in communication with radiating element **4211**, comprises a first set of active splitters **4212A**, **4212B**, **4212C** and a second set of active splitters **4213A**, **4213B**, **4213C**. In various embodiments, first subcircuit **4210** further comprises a first set of active vector generators **4214A**, **4214B**, **4214C**, **4214D** and a second set of active vector generators **4215A**, **4215B**, **4215C**, **4215D**. In an exemplary embodiment, a digital control (not shown) com-

municates polarization and beam steering commands to the first set of active vector generators **4214A**, **4214B**, **4214C**, **4214D** and the second set of active vector generators **4215A**, **4215B**, **4215C**, **4215D**. Additionally, first subcircuit **4210** comprises a set of active power combiners **4216A**, **4216B**, **4216C**, **4216D** that can be configured to output four intermediate signals for further processing in phased array integrated circuit **4200**.

[0233] The first set of active splitters **4212A**, **4212B**, **4212C** receives a vertical beam signal from radiating element **4211**. The first set of active splitters **4212A**, **4212B**, **4212C** divides the vertical beam signal into four intermediate vertical beam signals for transmitting to the first set of active vector generators **4214A**, **4214B**, **4214C**, **4214D**. One intermediate vertical beam signal is communicated to each one of the first set of active vector generators **4214A**, **4214B**, **4214C**, **4214D**.

[0234] Similarly, the second set of active splitters **4213A**, **4213B**, **4213C**, **4213D** receives a horizontal beam signal from radiating element **4211**. The second set of active splitters **4213A**, **4213B**, **4213C**, **4213D** divides the horizontal beam signal into four intermediate horizontal beam signals for transmitting to the second set of active vector generators **4215A**, **4215B**, **4215C**, **4215D**. One intermediate horizontal beam signal is communicated to each one of the second set of active vector generators **4215A**, **4215B**, **4215C**, **4215D**.

[0235] The formation of the signals combined by active power combiners **4216A**, **4216B**, **4216C**, **4216D** are similar in nature and operation, and therefore only the signal formation at active power combiner **4216A** will be described in detail. In various embodiments, active power combiner **4216A** receives a first feed signal from active vector generator **4214A** and a second feed signal from active vector generator **4215A**. The combined signal formed by active power combiner **4216A** can be any polarization, including linear, circular, elliptical, or slant polarization, depending on relative phases of the vertical output beam and the horizontal output beam. The first feed signal can be communicated with a phase angle of “ $\Theta$ ” in response to passing through active vector generator **4214A** and the second feed signal can be communicated with a phase angle of “ $\Theta$ ,” “ $\Theta+90^\circ$ ,” “ $\Theta-90^\circ$ ,” or “ $\Theta\pm 180^\circ$ ” in response to passing through active vector generator **4215A**. The polarization of the combined signal is based on the parameters of active vector generator **4214A** and the parameters of active vector generator **4215A**.

[0236] For example, active vector generator **4215A** communicating a “ $\Theta$ ” phase angle signal, if combined with a “ $\Theta$ ” phase angle signal from active vector generator **4214A**, results in active power combiner **4216A** generating a horizontal slant polarized first receive beam output. Additionally, active vector generator **4215A** communicating a “ $\Theta+90^\circ$ ” phase angle signal, if combined with a “ $\Theta$ ” phase angle signal from active vector generator **4214A**, results in active power combiner **4216A** generating a right hand circular polarized (RHCP) first receive beam output. Further, active vector generator **4215A** communicating a “ $\Theta-90^\circ$ ” phase angle signal, if combined with a “ $\Theta$ ” phase angle signal from active vector generator **4214A**, results in active power combiner **4216A** generating a left hand circular polarized (LHCP) first receive beam output. Moreover, active vector generator **4215A** communicating a “ $\Theta\pm 180^\circ$ ” phase shifted signal, if combined with a “ $\Theta$ ” phase angle

signal from active vector generator **4214A**, results in active power combiner **4216A** generating a vertical slant polarized first receive beam output.

[0237] Similarly, active power combiner **4216B** receives signals from active vector generator **4214B** and **4215B**, active power combiner **4216C** receives signals from active vector generator **4214C** and **4215C**, and active power combiner **4216D** receives signals from active vector generator **4214D** and **4215D**. Further, each active power combiner **4216B**, **4216C**, **4216D** individually outputs a signal with a polarization that depends on the parameters of the respective pairs of active vector generators.

[0238] In various exemplary embodiments, first subcircuit **4210** is configured to provide complete polarization flexibility on a beam by beam basis. In an exemplary embodiment, a digital control (not shown) communicates polarization and beam steering commands to the first and second sets of active vector generators.

[0239] In accordance with an exemplary embodiment, a first receive beam output is generated by combining one of the four output signals from each of four subcircuits **4210**, **4220**, **4230**, **4240**. A second receive beam output is generated by combining a second of the four output signals from each of four subcircuits **4210**, **4220**, **4230**, **4240**. A third receive beam output is generated by combining a third of the four output signals from each of four subcircuits **4210**, **4220**, **4230**, **4240**. A fourth receive beam output is generated by combining a fourth of the four output signals from each of four subcircuits **4210**, **4220**, **4230**, **4240**. In an exemplary embodiment, multiple combiners are used to combine the subcircuit output signals into the four receive beam outputs.

[0240] In a more specific exemplary embodiment, an active combiner **4251** is configured to combine the first of the four outputs from first and second subcircuits **4210**, **4220**. Furthermore, an active combiner **4261** is configured to combine the second of the four outputs from first and second subcircuits **4210**, **4220**. Likewise, an active combiner **4271** is configured to combine the third of the four outputs from first and second subcircuits **4210**, **4220**. An active combiner **4281** is configured to combine the fourth of the four outputs from first and second subcircuits **4210**, **4220**.

[0241] Also in the exemplary embodiment, an active combiner **4252** is configured to combine the first of the two outputs from third and fourth subcircuits **4230**, **4240**. An active combiner **4262** is configured to combine the second of the four outputs from third and fourth subcircuits **4230**, **4240**. Furthermore, an active combiner **4272** is configured to combine the third of the four outputs from third and fourth subcircuits **4230**, **4240**. An active combiner **4282** is configured to combine the fourth of the four outputs from third and fourth subcircuits **4230**, **4240**.

[0242] At the next stage, an active combiner **4253** is configured to combine the combined outputs of active combiners **4251**, **4252** to form a first receive beam output. An active combiner **4263** is configured to combine the combined outputs of active combiners **4261**, **4262** to form a second receive beam output. Furthermore, an active combiner **4273** is configured to combine the combined outputs of active combiners **4271**, **4272** to form a third receive beam output. An active combiner **4283** is configured to combine the combined outputs of active combiners **4281**, **4282** to form a fourth receive beam output.

[0243] In an exemplary embodiment, and with reference to FIGS. **43A** and **43B**, a phased array integrated circuit

**4300** is configured as a 4-beam, 4-radiating element transmitter. The phased array IC **4300** comprises a first subcircuit **4310** in communication with a first radiating element **4311**, a second subcircuit **4320** in communication with a second radiating element **4321**, a third subcircuit **4330** in communication with a third radiating element **4331**, and a fourth subcircuit **4340** in communication with a fourth radiating element **4341**. Each subcircuit **4310**, **4320**, **4330**, **4340** receives four input signals and transmits RF signals to the spatially orthogonal ports of the respectively coupled radiating element **4311**, **4321**, **4331**, **4341**.

[0244] In accordance with an exemplary embodiment, a first, second, third, and fourth transmit beam are provided to phased array IC **4300**. In an exemplary embodiment, multiple splitters are used to divide the first, second, third, and fourth transmit beams that are communicated to each of four subcircuits **4310**, **4320**, **4330**, **4340** as input signals.

[0245] In a more specific exemplary embodiment, an active splitter **4353** is configured to divide the first transmit beam input into two separate signals that are communicated to an active splitter **4351** and an active splitter **4352**, respectively. Similarly, an active splitter **4363** is configured to divide the second transmit beam input into two separate signals that are communicated to an active splitter **4361** and an active splitter **4362**, respectively. In an exemplary embodiment, an active splitter **4373** is configured to divide the third transmit beam input into two separate signals that are communicated to an active splitter **4371** and an active splitter **4372**, respectively. Furthermore, an active splitter **4383** is configured to divide the fourth transmit beam input into two separate signals that are communicated to an active splitter **4381** and an active splitter **4382**, respectively.

[0246] At the next stage, active splitters **4351**, **4361**, **4371**, **4381** are configured to divide the communicated signals and communicate the divided signals to first subcircuit **4310** and second subcircuit **4320**. The active splitters **4352**, **4362**, **4372**, **4382** are configured to divide the communicated signals and communicate the divided signals to third subcircuit **4330** and fourth subcircuit **4340**.

[0247] The structure and function of each subcircuit **4310**, **4320**, **4330**, **4340** is substantially similar. Thus, only first subcircuit **4310** will be discussed in detail. In accordance with an exemplary embodiment and with reference to FIG. **43B**, first subcircuit **4310**, in communication with radiating element **4311**, comprises a first set of active power combiners **4312A**, **4312B**, **4312C** and a second set of active power combiners **4313A**, **4313B**, **4313C**. In various embodiments, first subcircuit **4310** further comprises a first set of active vector generators **4314A**, **4314B**, **4314C**, **4314D** and a second set of active vector generators **4315A**, **4315B**, **4315C**, **4315D**. In an exemplary embodiment, a digital control (not shown) communicates polarization and beam steering commands to the first set of active vector generators **4314A**, **4314B**, **4314C**, **4314D** and the second set of active vector generators **4315A**, **4315B**, **4315C**, **4315D**. Additionally, first subcircuit **4310** comprises a set of active power splitters **4316A**, **4316B**, **4316C**, **4316D** that can be configured to receive four input beam signals for further processing in phased array integrated circuit **4300**.

[0248] In various embodiments, the active power splitters **4316A**, **4316B**, **4316C**, **4316D** each receive a divided transmit beam input, and are each in communication with two active vector generators. The operation of the active power splitters and active vector generators receiving the four input

beam signals are similar in nature and operation, and therefore only a single grouping of a power splitter and active vector generators will be described in detail.

[0249] In an exemplary embodiment, active power splitter **4316A** is configured to divide a first transmit beam input into a first pair of feed signals. One of the pair of feed signals is communicated to active vector generator **4314A** and the other intermediate signal is communicated to active vector generator **4315A**. Each of active vector generators **4314A**, **4315A** is configured to phase shift the respective feed signal to generate a phase shifted signal with a desired polarization. The specific phase shift is dependent upon the polarization of the first input beam and the polarization of the desired phase shifted signal. In order to transmit a cohesive signal from radiating element **4311**, the polarization of the desired phase shifted signal is the same for both the first and second sets of active vector generators.

[0250] In various embodiments, active vector generator **4314A** communicates a first vertical beam signal having a beam steering angle of " $\Theta_a$ " to a combiner, such as first set of active power combiners **4312A**, **4312B**, **4312C**. In accordance with an exemplary embodiment, first set of active power combiners **4312A**, **4312B**, **4312C** receives a plurality of input signals, such as from the first set of active vector generators **4314A**, **4314B**, **4314C**, **4314D**. The plurality of inputs signals are already appropriately phase shifted based on the desired polarization. The desired polarization can include linear, circular, elliptical, or slant polarization, depending on the parameters of active vector generator **4314A** and the parameters of active vector generator **4315A**. In various embodiments, the first set of active power combiners may combine the plurality of input signals in any order as would be understood by one skilled in the art based on the disclosure. The plurality of input signals are combined in a single a vertical output beam.

[0251] Similarly, in various embodiments, active vector generator **4315A** communicates a first horizontal beam signal to a combiner, such as second set of active power combiners **4313A**, **4313B**, **4313C**. The beam steering angle of the first horizontal output beam is set based on the desired polarization of the phased shifted signal. In accordance with an exemplary embodiment, second set of active power combiners **4313A**, **4313B**, **4313C** receives a plurality of input signals, such as from the second set of active vector generators **4315A**, **4315B**, **4315C**, **4315D**. The plurality of inputs signals are already appropriately phase shifted based on the desired polarization. In various embodiments, the second set of active power combiners may combine the plurality of input signals in any order as would be understood by one skilled in the art based on the disclosure. The plurality of input signals are combined in a single a horizontal output beam.

[0252] In accordance with various embodiments, the vertical output beam and the horizontal output beam can be transmitted via radiating element **4311** as a transmit beam output. The transmit beam output can be any polarization type, including linear, circular, elliptical, or slant polarization, depending on relative phases of the vertical output beam and the horizontal output beam. As previously described, the relative phases of the vertical output beam and the horizontal output beam are based on the parameters of first active vector generators **4314A**, **4314B**, **4314C**, **4314D** and the parameters of second active vector generators **4315A**, **4315B**, **4315C**, **4315D**. For example, active vector

generator **4315A** communicating a “ $\Theta$ ” phase angle signal, if combined with a “ $\Theta$ ” phase angle signal from active vector generator **4314A**, results in the first transmit beam being transmitted as a horizontal slant polarized transmit beam output. Additionally, active vector generator **4315A** communicating a “ $\Theta+90^\circ$ ” phase angle signal, if combined with a “ $\Theta$ ” phase angle signal from active vector generator **4314A**, results in the first transmit beam being transmitted as a RHCP transmit beam output. Further, active vector generator **4315A** communicating a “ $\Theta-90^\circ$ ” phase angle signal, if combined with a “ $\Theta$ ” phase angle signal from active vector generator **4314A**, results in the first transmit beam being transmitted as a LHCP transmit beam output. Moreover, active vector generator **4315A** communicating a “ $\Theta+180^\circ$ ” phase shifted signal, if combined with a “ $\Theta$ ” phase angle signal from active vector generator **4314A**, results in the first transmit beam input being transmitted as a vertical slant polarized transmit beam output.

**[0253]** In various exemplary embodiments, first subcircuit **4310** is configured to provide complete polarization flexibility on a beam by beam basis. In an exemplary embodiment, a digital control (not shown) communicates polarization and beam steering commands to the first and second sets of active vector generators.

**[0254]** In an exemplary embodiment, software reconfiguration of the active vector generators occurs in real-time as the system is operating, which enables a phased array antenna to have the capabilities previously described. Additionally, in the exemplary embodiment, there are no hardware changes that require physical and/or manual operations for polarization changing or system alterations. In other words, in an exemplary embodiment, the phased array antenna is fully electronically adjusted, which results in greater degrees of freedom compared to typical systems. Furthermore, the dynamic control of signal polarization of a phased array antenna has numerous applications.

**[0255]** In one application embodiment, dynamic control of signal polarization is implemented for secure communications by utilizing polarization hopping. Communication security can be enhanced by changing the polarization of a communications signal at a rate known to other authorized users. An unauthorized user will not know the correct polarization for any given instant and if using a constant polarization, the unauthorized user would only have the correct polarization for brief instances in time. A similar application to polarization hopping for secure communications is to use polarization hopping for signal scanning. In other words, the polarization of the antenna can be continuously adjusted to monitor for signal detection.

**[0256]** In an exemplary embodiment, dynamic control of signal polarization facilitates radar target identification using a single antenna. Radar target identification systems use information from multiple polarizations to provide increased target identification information. Additionally, a reflected signal's polarization and signal strength can be changed by the object off which it reflects. Thus, in an exemplary embodiment, a single antenna is configured to receive multiple polarizations and produce better identification due to acquiring more information about the target.

**[0257]** 4 Color System: In the field of consumer satellite RF communication, a satellite will typically transmit and/or receive data (e.g., movies and other television programming, internet data, and/or the like) to consumers who have personal satellite dishes at their home. More recently, the

satellites may transmit/receive data from more mobile platforms (such as, transceivers attached to airplanes, trains, and/or automobiles). It is anticipated that increased use of handheld or portable satellite transceivers will be the norm in the future. Although sometimes described in this document in connection with home satellite transceivers, the prior art limitations now discussed may be applicable to any personal consumer terrestrial transceivers (or transmitters or receivers) that communicate with a satellite.

**[0258]** A propagating radio frequency (RF) signal can have different polarizations, namely linear, elliptical, or circular. Linear polarization consists of vertical polarization and horizontal polarization, whereas circular polarization consists of left-hand circular polarization (LHCP) and right-hand circular polarization (RHCP). An antenna is typically configured to pass one polarization, such as LHCP, and reject the other polarization, such as RHCP.

**[0259]** Also, conventional very small aperture terminal (VSAT) antennas utilize a fixed polarization that is hardware dependent. The basis polarization is generally set during installation of the satellite terminal, at which point the manual configuration of the polarizer hardware is fixed. For example, a polarizer is generally set for LHCP or RHCP and fastened into position. To change polarization in a conventional VSAT antenna might require unfastening the polarizer, rotating it  $90^\circ$  to the opposite circular polarization, and then refastening the polarizer. Clearly this could not be done with much frequency and only a limited number (on the order of 5 or may be 10) of transceivers could be switched per technician in a given day.

**[0260]** Unlike a typical single polarization antenna, some devices are configured to change polarizations without disassembling the antenna terminal. As an example, a prior embodiment is the use of “baseball” switches to provide electronically commandable switching between polarizations. The rotation of the “baseball” switches causes a change in polarization by connecting one signal path and terminating the other signal path. However, each “baseball” switch requires a separate rotational actuator with independent control circuitry, which increases the cost of device such that this configuration is not used (if at all) in consumer broadband or VSAT terminals, but is instead used for large ground stations with a limited number of terminals.

**[0261]** Furthermore, another approach is to have a system with duplicate hardware for each polarization. The polarization selection is achieved by completing or enabling the path of the desired signal and deselecting the undesired signal. This approach is often used in receive-only terminals, for example satellite television receivers having low-cost hardware. However, with two way terminals that both transmit and receive such as VSAT or broadband terminals, doubling the hardware greatly increases the cost of the terminal.

**[0262]** Conventional satellites may communicate with the terrestrial based transceivers via radio frequency signals at a particular frequency band and a particular polarization. Each combination of a frequency band and polarization is known as a “color.” The satellite will transmit to a local geographic area with signals in a “beam” and the geographic area that can access signals on that beam may be represented by “spots” on a map. Each beam/spot will have an associated “color.” Thus, beams of different colors will not have the same frequency, the same polarization, or both.



**[0263]** In practice, there is some overlap between adjacent spots, such that at any particular point there may be two, three, or more beams that are “visible” to any one terrestrial transceiver. Adjacent spots will typically have different “colors” to reduce noise/interference from adjacent beams.

**[0264]** In the prior art, broadband consumer satellite transceivers are typically set to one color and left at that setting for the life of the transceiver. Should the color of the signal transmitted from the satellite be changed, all of the terrestrial transceivers that were communicating with that satellite on that color would be immediately stranded or cut off. Typically, a technician would have to visit the consumer’s home and manually change out (or possibly physically disassemble and re-assemble) the transceiver or polarizer to make the consumer’s terrestrial transceiver once again be able to communicate with the satellite on the new “color” signal. The practical effect of this is that in the prior art, no changes are made to the signal color transmitted from the satellite.

**[0265]** For similar reasons, a second practical limitation is that terrestrial transceivers are typically not changed from one color to another (i.e., if they are changed, it is a manual process). Thus, there is a need for a new low cost method and device to remotely change the frequency and/or polarization of an antenna system. There is also a need for a method and device that may be changed nearly instantaneously and often.

**[0266]** In spot beam communication satellite systems, both frequency and polarization diversity are utilized to reduce interference from adjacent spot beams. In an exemplary embodiment, both frequencies and polarizations are re-used in other beams that are geographically separated to maximize communications traffic capacity. The spot beam patterns are generally identified on a map using different colors to identify the combination of frequency and polarity used in that spot beam. The frequency and polarity re-use pattern is then defined by how many different combinations (or “colors”) are used.

**[0267]** In accordance with various exemplary embodiments and with reference to FIG. 28, an antenna system is configured for frequency and polarization switching. In one specific exemplary embodiment, the frequency and polarization switching comprises switching between two frequency ranges and between two different polarizations. This may be known as four color switching. In other exemplary embodiments, the frequency and polarization switching comprises switching between three frequency ranges and between two different polarizations, for a total of six separate colors. Furthermore, in various exemplary embodiments, the frequency and polarization switching may comprise switching between two polarizations with any suitable number of frequency ranges. In another exemplary embodiment, the frequency and polarization switching may comprise switching between more than two polarizations with any suitable number of frequency ranges.

**[0268]** In accordance with various exemplary embodiments, the ability to perform frequency and polarization switching has many benefits in terrestrial microwave communications terminals. For example, doing so may facilitate increased bandwidth, load shifting, roaming, increased data rate/download speeds, improved overall efficiency of a group of users on the system, or improved individual data communication rates. Terrestrial microwave communications terminals, in one exemplary embodiment, comprise point to point terminals. In another exemplary embodiment,

terrestrial microwave communications terminals comprise ground terminals for use in communication with any satellite, such as a satellite configured to switch frequency range and/or polarity of a RF signal broadcasted. These terrestrial microwave communications terminals are spot beam based systems.

**[0269]** In accordance with various exemplary embodiments, a satellite configured to communicate one or more RF signal beams each associated with a spot and/or color has many benefits in microwave communications systems. For example, similar to what was stated above for exemplary terminals in accordance with various embodiments, doing so may facilitate increased bandwidth, load shifting, roaming, increased data rate/download speeds, improved overall efficiency of a group of users on the system, or improved individual data communication rates. In accordance with another exemplary embodiment, the satellite is configured to remotely switch frequency range and/or polarity of a RF signal broadcasted by the satellite. This has many benefits in microwave communications systems. In another exemplary embodiment, satellites are in communications with any suitable terrestrial microwave communications terminal, such as a terminal having the ability to perform frequency and/or polarization switching.

**[0270]** Prior art spot beam based systems use frequency and polarization diversity to reduce or eliminate interference from adjacent spot beams. This allows frequency reuse in non-adjacent beams resulting in increased satellite capacity and throughput. Unfortunately, in the prior art, in order to have such diversity, installers of such systems must be able to set the correct polarity at installation or carry different polarity versions of the terminal. For example, at an installation site, an installer might carry a first terminal configured for left hand polarization and a second terminal configured for right hand polarization and use the first terminal in one geographic area and the second terminal in another geographic area. Alternatively, the installer might be able to disassemble and reassemble a terminal to switch it from one polarization to another polarization. This might be done, for example, by removing the polarizer, rotating it 90°, and reinstalling the polarizer in this new orientation. These prior art solutions are cumbersome in that it is not desirable to have to carry a variety of components at the installation site. Also, the manual disassembly/reassembly steps introduce the possibility of human error and/or defects.

**[0271]** These prior art solutions, moreover, for all practical purposes, permanently set the frequency range and polarization for a particular terminal. This is so because any change to the frequency range and polarization will involve the time and expense of a service call. An installer would have to visit the physical location and change the polarization either by using the disassembly/re-assembly technique or by just switching out the entire terminal. In the consumer broadband satellite terminal market, the cost of the service call can exceed the cost of the equipment and in general manually changing polarity in such terminals is economically unfeasible.

**[0272]** In accordance with various exemplary embodiments, a low cost system and method for electronically or electro-mechanically switching frequency ranges and/or polarity is provided. In an exemplary embodiment, the frequency range and/or polarization of a terminal can be changed without a human touching the terminal. Stated another way, the frequency range and/or polarization of a

terminal can be changed without a service call. In an exemplary embodiment, the system is configured to remotely cause the frequency range and/or polarity of the terminal to change.

**[0273]** In one exemplary embodiment, the system and method facilitate installing a single type of terminal that is capable of being electronically set to a desired frequency range from among two or more frequency ranges. Some exemplary frequency ranges include receiving 10.7 GHz to 12.75 GHz, transmitting 13.75 GHz to 14.5 GHz, receiving 18.3 GHz to 20.2 GHz, and transmitting 28.1 GHz to 30.0 GHz. Furthermore, other desired frequency ranges of a point-to-point system fall within 15 GHz to 38 GHz. In another exemplary embodiment, the system and method facilitate installing a single type of terminal that is capable of being electronically set to a desired polarity from among two or more polarities. The polarities may comprise, for example, left hand circular, right hand circular, vertical linear, horizontal linear, or any other orthogonal polarization. Moreover, in various exemplary embodiments, a single type of terminal may be installed that is capable of electronically selecting both the frequency range and the polarity of the terminal from among choices of frequency range and polarity, respectively.

**[0274]** In an exemplary embodiment, transmit and receive signals are paired so that a common switching mechanism switches both signals simultaneously. For example, one “color” may be a receive signal in the frequency range of 19.7 GHz to 20.2 GHz using RHCP, and a transmit signal in the frequency range of 29.5 GHz to 30.0 GHz using LHCP. Another “color” may use the same frequency ranges but transmit using RHCP and receive using LHCP. Accordingly, in an exemplary embodiment, transmit and receive signals are operated at opposite polarizations. However, in some exemplary embodiments, transmit and receive signals are operated on the same polarization which increases the signal isolation requirements for self-interference free operation.

**[0275]** Thus, a single terminal type may be installed that can be configured in a first manner for a first geographical area and in a second manner for a second geographical area that is different from the first area, where the first geographical area uses a first color and the second geographical area uses a second color different from the first color.

**[0276]** In accordance with an exemplary embodiment, a terminal, such as a terrestrial microwave communications terminal, may be configured to facilitate load balancing. In accordance with another exemplary embodiment, a satellite may be configured to facilitate load balancing. Load balancing involves moving some of the load on a particular satellite, or point-to-point system, from one polarity/frequency range “color” or “beam” to another. In an exemplary embodiment, the load balancing is enabled by the ability to remotely switch frequency range and/or polarity of either the terminal or the satellite.

**[0277]** Thus, in exemplary embodiments, a method of load balancing comprises the steps of remotely switching frequency range and/or polarity of one or more terrestrial microwave communications terminals. For example, system operators or load monitoring computers may determine that dynamic changes in system bandwidth resources has created a situation where it would be advantageous to move certain users to adjacent beams that may be less congested. In one example, those users may be moved back at a later time as the loading changes again. In an exemplary embodiment,

this signal switching (and therefore this satellite capacity “load balancing”) can be performed periodically. In other exemplary embodiments, load balancing can be performed on many terminals (e.g., hundreds or thousands of terminals) simultaneously or substantially simultaneously. In other exemplary embodiments, load balancing can be performed on many terminals without the need for thousands of user terminals to be manually reconfigured.

**[0278]** In one exemplary embodiment, dynamic control of signal polarization is implemented for secure communications by utilizing polarization hopping. Communication security can be enhanced by changing the polarization of a communications signal at a rate known to other authorized users. An unauthorized user will not know the correct polarization for any given instant and if using a constant polarization, the unauthorized user would only have the correct polarization for brief instances in time. A similar application to polarization hopping for secure communications is to use polarization hopping for signal scanning. In other words, the polarization of the antenna can be continuously adjusted to monitor for signal detection.

**[0279]** In an exemplary embodiment, the load balancing is performed as frequently as necessary based on system loading. For example, load balancing could be done on a seasonal basis. For example, loads may change significantly when schools, colleges, and the like start and end their sessions. As another example, vacation seasons may give rise to significant load variations. For example, a particular geographic area may have a very high load of data traffic. This may be due to a higher than average population density in that area, a higher than average number of transceivers in that area, or a higher than average usage of data transmission in that area. In another example, load balancing is performed on an hourly basis. Furthermore, load balancing could be performed at any suitable time. In one example, if maximum usage is between 6-7 p.m. at night, then some of the users in the heaviest loaded beam areas could be switched to adjacent beams in a different time zone. In another example, if a geographic area comprises both office and home terminals, and the office terminals experience heaviest loads at different times than the home terminals, the load balancing may be performed between home and office terminals. In yet another embodiment, a particular area may have increased localized signal transmission traffic, such as related to high traffic within businesses, scientific research activities, graphic/video intensive entertainment data transmissions, a sporting event or a convention. Stated another way, in an exemplary embodiment, load balancing may be performed by switching the color of any subgroup(s) of a group of transceivers.

**[0280]** In an exemplary embodiment, the consumer broadband terrestrial terminal is configured to determine, based on preprogrammed instructions, what colors are available and switch to another color of operation. For example, the terrestrial terminal may have visibility to two or more beams (each of a different color). The terrestrial terminal may determine which of the two or more beams is better to connect to. This determination may be made based on any suitable factor. In one exemplary embodiment, the determination of which color to use is based on the data rate, the download speed, and/or the capacity on the beam associated with that color. In other exemplary embodiments, the determination is made randomly, or in any other suitable way.

**[0281]** This technique is useful in a geographically stationary embodiment because loads change over both short and long periods of time for a variety of reasons and such self adjusting of color selection facilitates load balancing. This technique is also useful in mobile satellite communication as a form of “roaming.” For example, in one exemplary embodiment, the broadband terrestrial terminal is configured to switch to another color of operation based on signal strength. This is, in contrast to traditional cell phone type roaming, where that roaming determination is based on signal strength. In contrast, here, the color distribution is based on capacity in the channel. Thus, in an exemplary embodiment, the determination of which color to use may be made to optimize communication speed as the terminal moves from one spot to another. Alternatively, in an exemplary embodiment, a color signal broadcast by the satellite may change or the spot beam may be moved and still, the broadband terrestrial terminal may be configured to automatically adjust to communicate on a different color (based, for example, on channel capacity).

**[0282]** In accordance with another exemplary embodiment, a satellite is configured to communicate one or more RF signal beams each associated with a spot and/or color. In accordance with another exemplary embodiment, the satellite is configured to remotely switch frequency range and/or polarity of a RF signal broadcasted by the satellite. In another exemplary embodiment, a satellite may be configured to broadcast additional colors. For example, an area and/or a satellite might only have 4 colors at a first time, but two additional colors, (making 6 total colors) might be dynamically added at a second time. In this event, it may be desirable to change the color of a particular spot to one of the new colors. With reference to FIG. 29A, spot 4 changes from “red” to then new color “yellow.” In one exemplary embodiment, the ability to add colors may be a function of the system’s ability to operate, both transmit and/or receive over a wide bandwidth within one device and to tune the frequency of that device over that wide bandwidth.

**[0283]** In accordance with an exemplary embodiment, and with renewed reference to FIG. 28, a satellite may have a downlink, an uplink, and a coverage area. The coverage area may be comprised of smaller regions each corresponding to a spot beam to illuminate the respective region. Spot beams may be adjacent to one another and have overlapping regions. A satellite communications system has many parameters to work: (1) number of orthogonal time or frequency slots (defined as color patterns hereafter); (2) beam spacing (characterized by the beam roll-off at the cross-over point); (3) frequency re-use patterns (the re-use patterns can be regular in structures, where a uniformly distributed capacity is required); and (4) numbers of beams (a satellite with more beams will provide more system flexibility and better bandwidth efficiency). Polarization may be used as a quantity to define a re-use pattern in addition to time or frequency slots. In one exemplary embodiment, the spot beams may comprise a first spot beam and a second spot beam. The first spot beam may illuminate a first region within a geographic area, in order to send information to a first plurality of subscriber terminals. The second spot beam may illuminate a second region within the geographic area and adjacent to the first region, in order to send information to a second plurality of subscriber terminals. The first and second regions may overlap.

**[0284]** The first spot beam may have a first characteristic polarization. The second spot beam may have a second characteristic polarization that is orthogonal to the first polarization. The polarization orthogonality serves to provide an isolation quantity between adjacent beams. Polarization may be combined with frequency slots to achieve a higher degree of isolation between adjacent beams and their respective coverage areas. The subscriber terminals in the first beam may have a polarization that matches the first characteristic polarization. The subscriber terminals in the second beam may have a polarization that matches the second characteristic polarization.

**[0285]** The subscriber terminals in the overlap region of the adjacent beams may be optionally assigned to the first beam or to the second beam. This optional assignment is a degree of flexibility within the satellite system and may be altered through reassignment following the start of service for any subscriber terminals within the overlapping region. The ability to remotely change the polarization of a subscriber terminal in an overlapping region illuminated by adjacent spot beams is an important improvement in the operation and optimization of the use of the satellite resources for changing subscriber distributions and quantities. For example it may be an efficient use of satellite resources and improvement to the individual subscriber service to reassign a user or a group of users from a first beam to a second beam or from a second beam to a first beam. Satellite systems using polarization as a quantity to provide isolation between adjacent beams may thus be configured to change the polarization remotely by sending a signal containing a command to switch or change the polarization from a first polarization state to a second orthogonal polarization state. The intentional changing of the polarization may facilitate reassignment to an adjacent beam in a spot beam satellite system using polarization for increasing a beam isolation quantity.

**[0286]** The down link may comprise multiple “colors” based on combinations of selected frequency and/or polarizations. Although other frequencies and frequency ranges may be used, and other polarizations as well, an example is provided of one multicolor embodiment. For example, and with renewed reference to FIG. 28, in the downlink, colors U1, U3, and U5 are Left-Hand Circular Polarized (“LHCP”) and colors U2, U4, and U6 are Right-Hand Circular Polarized (“RHCP”). In the frequency domain, colors U3 and U4 are from 18.3-18.8 GHz; U5 and U6 are from 18.8-19.3 GHz; and U1 and U2 are from 19.7-20.2 GHz. It will be noted that in this exemplary embodiment, each color represents a 500 MHz frequency range. Other frequency ranges may be used in other exemplary embodiments. Thus, selecting one of LHCP or RHCP and designating a frequency band from among the options available will specify a color. Similarly, the uplink comprises frequency/polarization combinations that can be each designated as a color. Often, the LHCP and RHCP are reversed as illustrated, providing increased signal isolation, but this is not necessary. In the uplink, colors U1, U3, and U5 are RHCP and colors U2, U4, and U6 are LHCP. In the frequency domain, colors U3 and U4 are from 28.1-28.6 GHz; U5 and U6 are from 28.6-29.1 GHz; and U1 and U2 are from 29.5-30.0 GHz. It will be noted that in this exemplary embodiment, each color similarly represents a 500 MHz frequency range.

**[0287]** In an exemplary embodiment, the satellite may broadcast one or more RF signal beam (spot beam) associ-

ated with a spot and a color. This satellite is further configured to change the color of the spot from a first color to a second, different, color. Thus, with renewed reference to FIG. 29A, spot 1 is changed from “red” to “blue.”

[0288] When the color of one spot is changed, it may be desirable to change the colors of adjacent spots as well. Again with reference to FIG. 29A, the map shows a group of spot colors at a first point in time, where this group at this time is designated 9110, and a copy of the map shows a group of spot colors at a second point in time, designated 9120. Some or all of the colors may change between the first point in time and the second point in time. For example spot 1 changes from red to blue and spot 2 changes from blue to red. Spot 3, however, stays the same. In this manner, in an exemplary embodiment, adjacent spots are not identical colors.

[0289] Some of the spot beams are of one color and others are of a different color. For signal separation, the spot beams of similar color are typically not located adjacent to each other. In an exemplary embodiment, and with reference again to FIG. 28, the distribution pattern illustrated provides one exemplary layout pattern for four color spot beam frequency re-use. It should be recognized that with this pattern, color U1 will not be next to another color U1, etc. It should be noted, however, that typically the spot beams will overlap and that the spot beams may be better represented with circular areas of coverage. Furthermore, it should be appreciated that the strength of the signal may decrease with distance from the center of the circle, so that the circle is only an approximation of the coverage of the particular spot beam. The circular areas of coverage may be overlaid on a map to determine what spot beam(s) are available in a particular area.

[0290] In accordance with an exemplary embodiment, the satellite is configured to shift one or more spots from a first geographic location to a second geographic location. This may be described as shifting the center of the spot from a first location to a second location. This might also be described as changing the effective size (e.g., diameter) of the spot. In accordance with an exemplary embodiment, the satellite is configured to shift the center of the spot from a first location to a second location and/or change the effective size of one or more spots. In the prior art, it would be unthinkable to shift a spot because such an action would strand terrestrial transceivers. The terrestrial transceivers would be stranded because the shifting of one or more spots would leave some terrestrial terminals unable to communicate with a new spot of a different color.

[0291] However, in an exemplary embodiment, the transceivers are configured to easily switch colors. Thus, in an exemplary method, the geographic location of one or more spots is shifted and the color of the terrestrial transceivers may be adjusted as needed.

[0292] In an exemplary embodiment, the spots are shifted such that a high load geographic region is covered by two or more overlapping spots. For example, with reference to FIGS. 29B and 29C, a particular geographic area 9210 may have a very high load of data traffic. In this exemplary embodiment, area 9210 is only served by spot 1 at a first point in time illustrated by FIG. 29B. At a second point in time illustrated by FIG. 29C, the spots have been shifted such that area 9210 is now served or covered by spots 1, 2, and 3. In this embodiment, terrestrial transceivers in area 9210 may be adjusted such that some of the transceivers are

served by spot 1, others by spot 2, and yet others by spot 3. In other words, transceivers in area 9210 may be selectively assigned one of three colors. In this manner, the load in this area can be shared or load-balanced.

[0293] In an exemplary embodiment, the switching of the satellites and/or terminals may occur with any regularity. For example, the polarization may be switched during the evening hours, and then switched back during business hours to reflect transmission load variations that occur over time. In an exemplary embodiment, the polarization may be switched thousands of times during the life of elements in the system.

[0294] In one exemplary embodiment, the color of the terminal is not determined or assigned until installation of the terrestrial transceiver. This is in contrast to units shipped from the factory set as one particular color. The ability to ship a terrestrial transceiver without concern for its “color” facilitates simpler inventory processes, as only one unit (as opposed to two or four or more) need be stored. In an exemplary embodiment, the terminal is installed, and then the color is set in an automated manner (i.e., the technician can’t make a human error) either manually or electronically. In another exemplary embodiment, the color is set remotely such as being assigned by a remote central control center. In another exemplary embodiment, the unit itself determines the best color and operates at that color.

[0295] As can be noted, the determination of what color to use for a particular terminal may be based on any number of factors. The color may be based on what signal is strongest, based on relative bandwidth available between available colors, randomly assigned among available colors, based on geographic considerations, based on temporal considerations (such as weather, bandwidth usage, events, work patterns, days of the week, sporting events, and/or the like), and/or the like. Previously, a terrestrial consumer broadband terminal was not capable of determining what color to use based on conditions at the moment of install or quickly, remotely varied during use.

[0296] In accordance with an exemplary embodiment, the system is configured to facilitate remote addressability of subscriber terminals. In one exemplary embodiment, the system is configured to remotely address a specific terminal. The system may be configured to address each subscriber terminal. In another exemplary embodiment, a group of subscriber terminals may be addressable. This may occur using any number of methods now known, or hereafter invented, to communicate instructions with a specific transceiver and/or group of subscriber terminals. Thus, a remote signal may command a terminal or group of terminals to switch from one color to another color. The terminals may be addressable in any suitable manner. In one exemplary embodiment, an internet protocol (IP) address is associated with each terminal. In an exemplary embodiment, the terminals may be addressable through the modems or set top boxes (e.g., via the internet). Thus, in accordance with an exemplary embodiment, the system is configured for remotely changing a characteristic polarization of a subscriber terminal by sending a command addressed to a particular terminal. This may facilitate load balancing and the like. The sub-group could be a geographic sub group within a larger geographic area, or any other group formed on any suitable basis.

[0297] In this manner, an individual unit may be controlled on a one to one basis. Similarly, all of the units in a

sub-group may be commanded to change colors at the same time. In one embodiment, a group is broken into small sub-groups (e.g., 100 sub-groups each comprising 1% of the terminals in the larger grouping). Other sub-groups might comprise 5%, 10%, 20%, 35%, 50% of the terminals, and the like. The granularity of the subgroups may facilitate more fine tuning in the load balancing.

**[0298]** Thus, an individual with a four color switchable transceiver that is located at location A on the map (see FIG. 28, Practical Distribution Illustration), would have available to them colors U1, U2, and U3. The transceiver could be switched to operate on one of those three colors as best suits the needs at the time. Likewise, location B on the map would have colors U1 and U3 available. Lastly, location C on the map would have color U1 available. In many practical circumstances, a transceiver will have two or three color options available in a particular area.

**[0299]** It should be noted that colors U5 and U6 might also be used and further increase the options of colors to use in a spot beam pattern. This may also further increase the options available to a particular transceiver in a particular location. Although described as a four or six color embodiment, any suitable number of colors may be used for color switching as described herein. Also, although described herein as a satellite, it is intended that the description is valid for other similar remote communication systems that are configured to communicate with the transceiver.

**[0300]** The frequency range/polarization of the terminal may be selected at least one of remotely, locally, manually, or some combination thereof. In one exemplary embodiment, the terminal is configured to be remotely controlled to switch from one frequency range/polarization to another. For example, the terminal may receive a signal from a central system that controls switching the frequency range/polarization. The central system may determine that load changes have significantly slowed down the left hand polarized channel, but that the right hand polarized channel has available bandwidth. The central system could then remotely switch the polarization of a number of terminals. This would improve channel availability for switched and non-switched users alike. Moreover, the units to switch may be selected based on geography, weather, use characteristics, individual bandwidth requirements, and/or other considerations. Furthermore, the switching of frequency range/polarization could be in response to the customer calling the company about poor transmission quality.

**[0301]** It should be noted that although described herein in the context of switching both frequency range and polarization, benefits and advantages similar to those discussed herein may be realized when switching just one of frequency or polarization.

**[0302]** The frequency range switching described herein may be performed in any number of ways. In an exemplary embodiment, the frequency range switching is performed electronically. For example, the frequency range switching may be implemented by adjusting phase shifters in a phased array, switching between fixed frequency oscillators or converters, and/or using a tunable dual conversion transmitter comprising a tunable oscillator signal. Additional aspects of frequency switching for use with the present invention are disclosed in U.S. application Ser. No. 12/614,293 entitled "DUAL CONVERSION TRANSMITTER WITH SINGLE

LOCAL OSCILLATOR" which was filed on Nov. 6, 2009; the contents of which are hereby incorporated by reference in their entirety.

**[0303]** In accordance with another exemplary embodiment, the polarization switching described herein may be performed in any number of ways. In an exemplary embodiment, the polarization switching is performed electronically by adjusting the relative phase of signals at orthogonal antenna ports. In another exemplary embodiment, the polarization switching is performed mechanically. For example, the polarization switching may be implemented by use of a trumpet switch. The trumpet switch may be actuated electronically. For example, the trumpet switch may be actuated by electronic magnet, servo, an inductor, a solenoid, a spring, a motor, an electro-mechanical device, or any combination thereof. Moreover, the switching mechanism can be any mechanism configured to move and maintain the position of trumpet switch.

**[0304]** Furthermore, in an exemplary embodiment, trumpet switch is held in position by a latching mechanism. The latching mechanism, for example, may be fixed magnets. The latching mechanism keeps trumpet switch in place until the antenna is switched to another polarization.

**[0305]** As described herein, the terminal may be configured to receive a signal causing switching and the signal may be from a remote source. For example, the remote source may be a central office. In another example, an installer or customer can switch the polarization using a local computer connected to the terminal which sends commands to the switch. In another embodiment, an installer or customer can switch the polarization using the television set-top box which in turn sends signals to the switch. The polarization switching may occur during installation, as a means to increase performance, or as another option for troubleshooting poor performance.

**[0306]** In other exemplary embodiments, manual methods may be used to change a terminal from one polarization to another. This can be accomplished by physically moving a switch within the housing of the system or by extending the switch outside the housing to make it easier to manually switch the polarization. This could be done by either an installer or customer.

**[0307]** Some exemplary embodiments of the above mentioned multi-color embodiments may benefits over the prior art. For instance, in an exemplary embodiment, a low cost consumer broadband terrestrial terminal antenna system may include an antenna, a transceiver in signal communication with the antenna, and a polarity switch configured to cause the antenna system to switch between a first polarity and a second polarity. In this exemplary embodiment, the antenna system may be configured to operate at the first polarity and/or the second polarity.

**[0308]** In an exemplary embodiment, a method of system resource load balancing is disclosed. In this exemplary embodiment, the method may include the steps of: (1) determining that load on a first spotbeam is higher than a desired level and that load on a second spotbeam is low enough to accommodate additional load; (2) identifying, as available for switching, consumer broadband terrestrial terminals on the first spot beam that are in view of the second spotbeam; (3) sending a remote command to the available for switching terminals; and (4) switching color in said terminals from the first beam to the second beam based on

the remote command. In this exemplary embodiment, the first and second spot beams are each a different color.

**[0309]** In an exemplary embodiment, a satellite communication system is disclosed. In this exemplary embodiment, the satellite communication system may include: a satellite configured to broadcast multiple spotbeams; a plurality of user terminal antenna systems in various geographic locations; and a remote system controller configured to command at least some of the subset of the plurality of user terminal antenna systems to switch at least one of a polarity and a frequency to switch from the first spot beam to the second spotbeam. In this exemplary embodiment, the multiple spot beams may include at least a first spotbeam of a first color and a second spotbeam of a second color. In this exemplary embodiment, at least a subset of the plurality of user terminal antenna systems may be located within view of both the first and second spotbeams.

**[0310]** The following applications are related to this subject matter: U.S. application Ser. No. 14/617,630, entitled MULTI-BEAM ACTIVE PHASED ARRAY ARCHITECTURE WITH INDEPENDENT POLARIZATION CONTROL,” filed on Feb. 9, 2015; U.S. Application No. 14,216,760, entitled MULTI-BEAM ACTIVE PHASED ARRAY ARCHITECTURE WITH INDEPENDENT POLARIZATION CONTROL,” filed on Mar. 17, 2014; U.S. application Ser. No. 12/759,123, entitled “ACTIVE BUTLER AND BLASS MATRICES,” filed on Apr. 13, 2010; U.S. application Ser. No. 12/759,043, entitled “ACTIVE HYBRIDS FOR ANTENNA SYSTEMS,” filed on Apr. 13, 2010; U.S. application Ser. No. 12/759,064, entitled “ACTIVE FEED FORWARD AMPLIFIER,” filed on Apr. 13, 2010; U.S. application Ser. No. 12/759,130, entitled “ACTIVE PHASED ARRAY ARCHITECTURE,” filed on Apr. 13, 2010; U.S. application Ser. No. 12/758,996, entitled “PRE-SELECTOR AMPLIFIER,” filed on Apr. 13, 2010; U.S. application Ser. No. 12/759,148, entitled “ACTIVE POWER SPLITTER,” filed on Apr. 13, 2010; U.S. application Ser. No. 12/759,112, entitled “HALF-DUPLEX PHASED ARRAY ANTENNA SYSTEM,” filed on Apr. 13, 2010; U.S. application Ser. No. 12/759,113, entitled “DIGITAL AMPLITUDE CONTROL OF ACTIVE VECTOR GENERATOR,” filed on Apr. 13, 2010; the contents of which are hereby incorporated by reference for any purpose in their entirety.

**[0311]** Benefits, other advantages, and solutions to problems have been described above with regard to specific embodiments. However, the benefits, advantages, solutions to problems, and any element(s) that may cause any benefit, advantage, or solution to occur or become more pronounced are not to be construed as critical, required, or essential features or elements of any or all the claims. As used herein, the terms “includes,” “including,” “comprises,” “comprising,” or any other variation thereof, are intended to cover a non-exclusive inclusion, such that a process, method, article, or apparatus that comprises a list of elements does not include only those elements but may include other elements not expressly listed or inherent to such process, method, article, or apparatus. Further, no element described herein is required for the practice of the invention unless expressly described as “essential” or “critical.”

What is claimed is:

1. (canceled)
2. A phased array circuit comprising:
  - a first vector generator to separately perform quadrant selection via phase inversion switching for each of a first in-phase vector and a first quadrature-phase vector associated with a first signal communicated between a first port of a dual polarized radiating element and a common signal path, and to separately perform relative amplification on each of the first in-phase vector and the first quadrature-phase vector of the first signal; and
  - a second vector generator to separately perform quadrant selection via phase inversion switching for each of a second in-phase vector and a second quadrature-phase vector associated with a second signal communicated between a second port of the dual polarized radiating element and the common signal path, and to separately perform relative amplification on each of the second in-phase vector and the second quadrature-phase vector of the second signal.
3. The phased array circuit of claim 2, wherein the first port and the second port of the dual-polarized radiating element are spatially orthogonal to each other.
4. The phased array circuit of claim 2, wherein the first port of the dual-polarized radiating element is associated with a first polarization, and wherein the second port of the dual-polarized radiating element is associated with a second polarization.
5. The phased array circuit of claim 2, wherein at least one of the first and second vector generators of the phased array circuit controls a polarization of the dual-polarized radiating element.
6. The phased array circuit of claim 2, further comprising a digital control device to communicate commands to the phased array circuit.
7. The phased array circuit of claim 6, wherein the phased array circuit further comprises:
  - a first digital-to-analog converter responsive to the commands to control the first vector generator to adjust the first signal; and
  - a second digital-to-analog converter responsive to the commands to control the second vector generator to adjust the second signal.
8. The phased array circuit of claim 6, wherein the commands to the phased array circuit control polarization of the dual-polarized radiating element via at least one of the first and the second vector generators.
9. The phased array circuit of claim 7, wherein the commands to the phased array circuit steer at least one beam of the adjusted first signal and the adjusted second signal of the phased array circuit.
10. The phased array circuit of claim 2, wherein the first and second vector generators of the phased array circuit adjust phase and amplitude of the first signal and the second signal, respectively.
11. The phased array circuit of claim 2, wherein the first port of the dual-polarized radiating element corresponds to a horizontal polarization and wherein the second port of the dual-polarized radiating element corresponds to a vertical polarization.
12. The phased array circuit of claim 2, wherein the first vector generator comprises a first power amplifier to increase the magnitude of the power of the first in-phase vector and a second power amplifier to increase the magnitude of the power of the first quadrature-phase vector; and wherein the second vector generator comprises a third power amplifier to increase the magnitude of the power of the second

second in-phase vector and a fourth power amplifier to increase the magnitude of the power of the second quadrature-phase vector.

13. The phased array circuit of claim 12, wherein the first power amplifier is a variable gain amplifier.

14. The phased array circuit of claim 2, wherein the phased array circuit is an integrated circuit.

15. The phased array circuit of claim 2, wherein the first signal corresponds to a horizontal polarization and wherein the second signal corresponds to a vertical polarization.

16. The phased array circuit of claim 2, wherein the quadrant selection for the first in-phase vector is selected by a first binary control signal; wherein the quadrant selection for the first quadrature-phase vector is selected by a second binary control signal; wherein the quadrant selection for the second in-phase vector is selected by a third binary control signal; and wherein the quadrant selection for the second quadrature-phase vector is selected by a fourth binary control signal.

17. The phased array circuit of claim 2, wherein performing the quadrature selection for each vector generator is based on a first binary command whether to invert the respective in-phase vector, and a second binary command whether to invert the respective quadrature-phase vector.

\* \* \* \* \*