



US 20050110913A1

(19) **United States**

(12) **Patent Application Publication**

Vitito

(10) **Pub. No.: US 2005/0110913 A1**

(43) **Pub. Date: May 26, 2005**

(54) **AUTOMOBILE ENTERTAINMENT SYSTEM**

on Jan. 8, 2004. Provisional application No. 60/571,516, filed on May 17, 2004.

(76) Inventor: **Christopher J. Vitito**, Lakeland, FL (US)

Publication Classification

Correspondence Address:
WELSH & FLAXMAN LLC
2450 CRYSTAL DRIVE
SUITE 112
ARLINGTON, VA 22202 (US)

(51) **Int. Cl.⁷ B60R 7/00**

(52) **U.S. Cl. 348/837**

(21) Appl. No.: **10/920,430**

(57) **ABSTRACT**

(22) Filed: **Aug. 18, 2004**

An automobile entertainment system includes a video system mounted within an automobile headrest. The headrest includes a headrest body in which the video system is mounted. The video system also includes an integrated housing supporting a video monitor and a television receiver.

Related U.S. Application Data

(60) Provisional application No. 60/517,862, filed on Nov. 7, 2003. Provisional application No. 60/534,705, filed

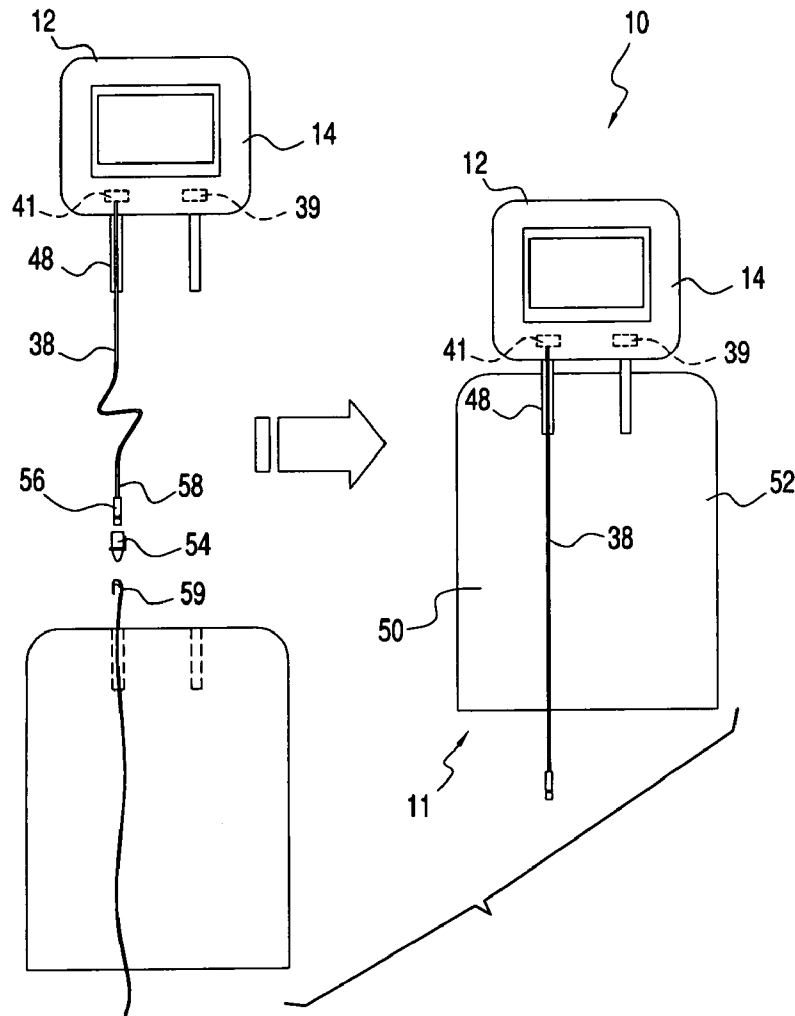

FIG. 1

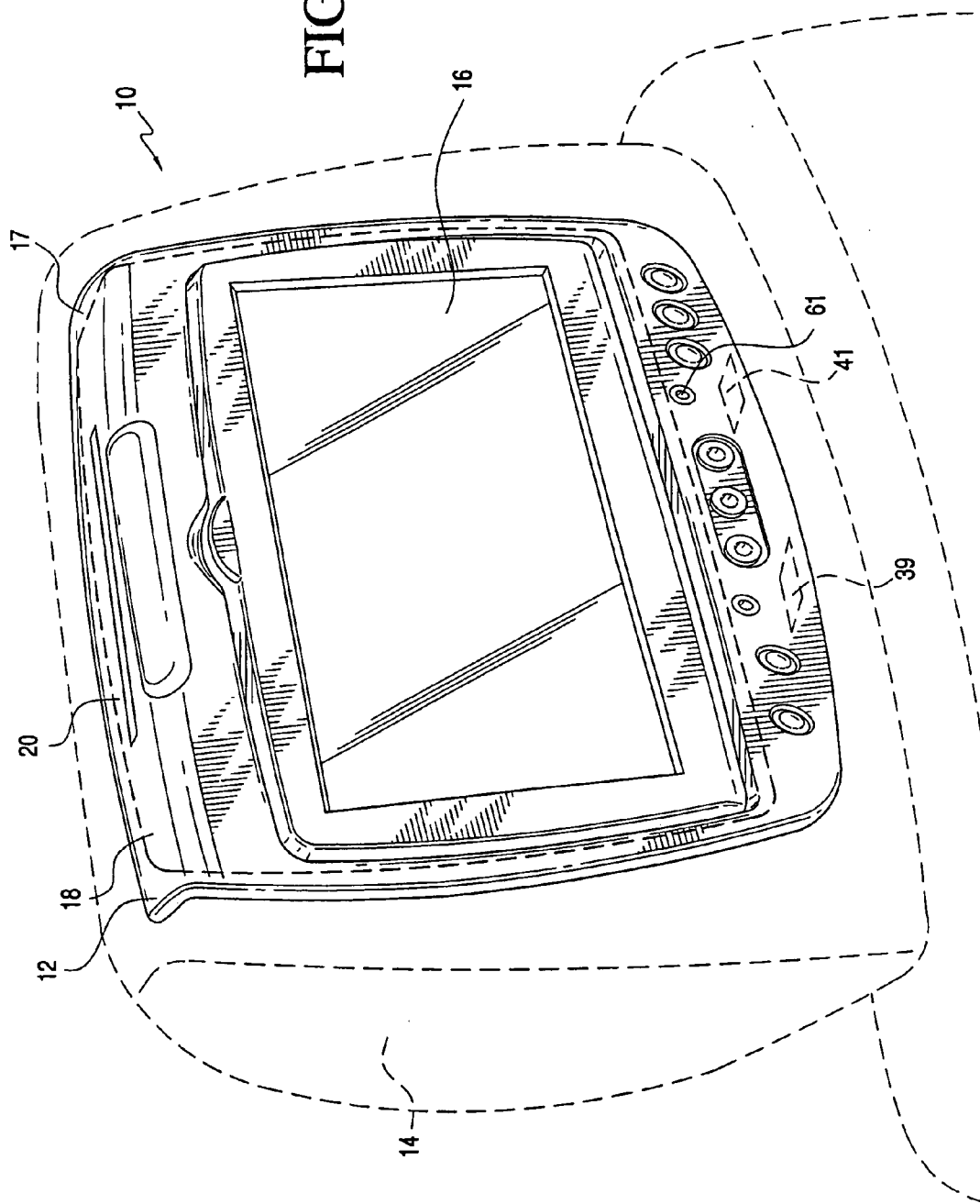

FIG.2

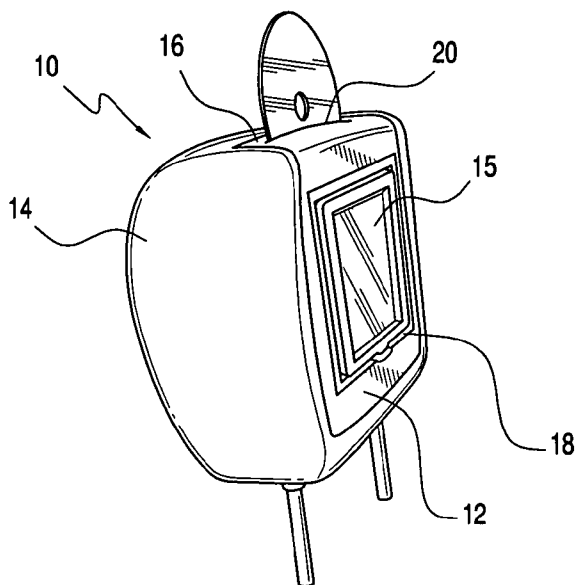

FIG.3

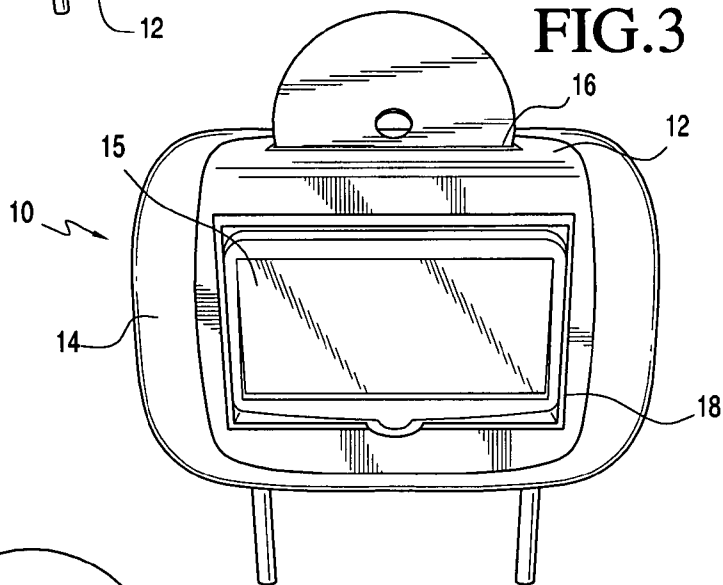
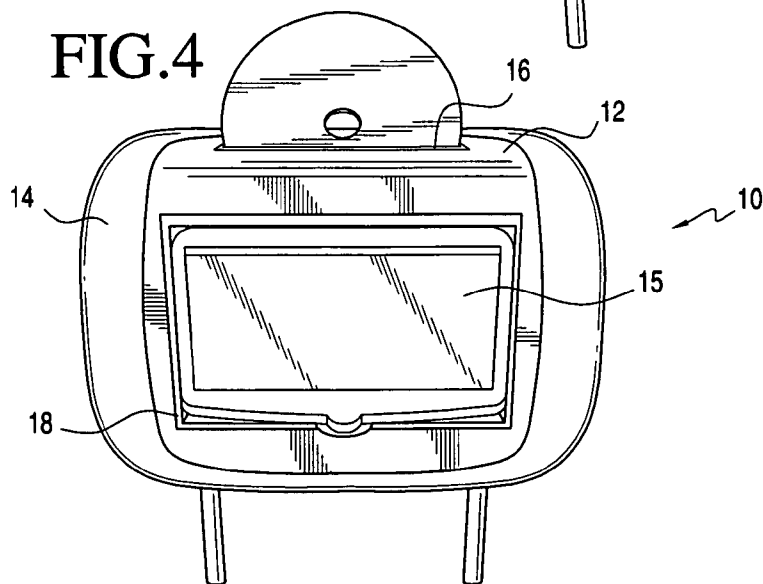

FIG.4



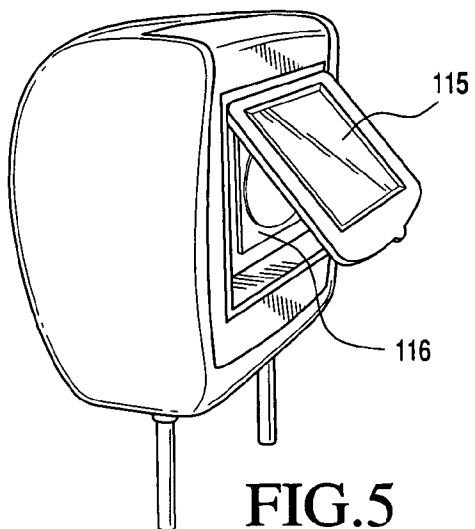

FIG. 5

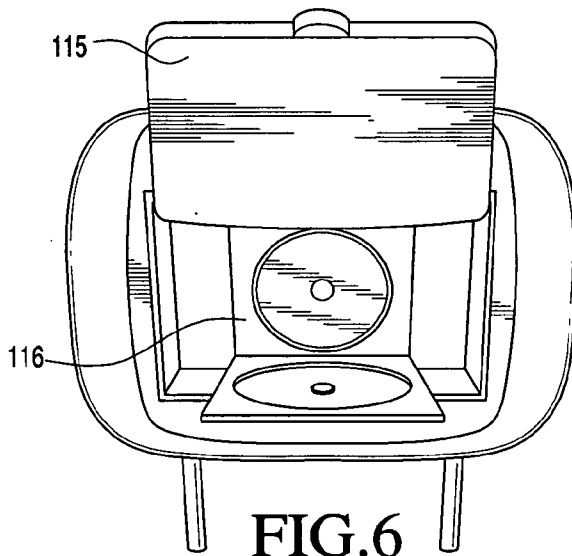

FIG. 6

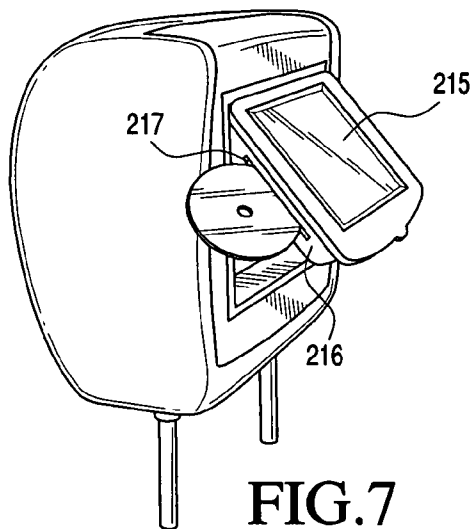

FIG. 7

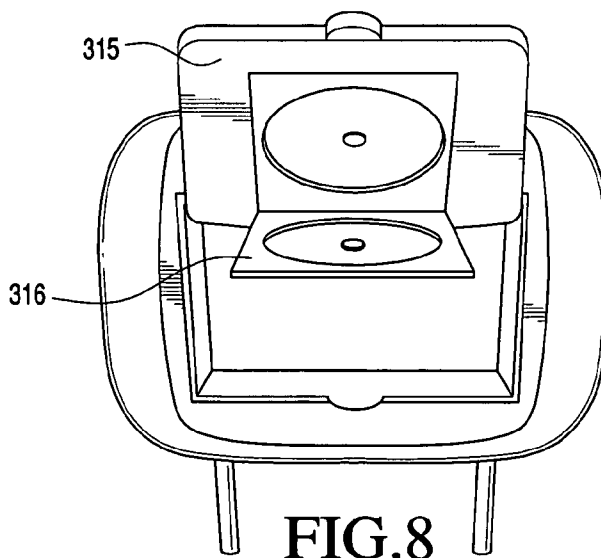
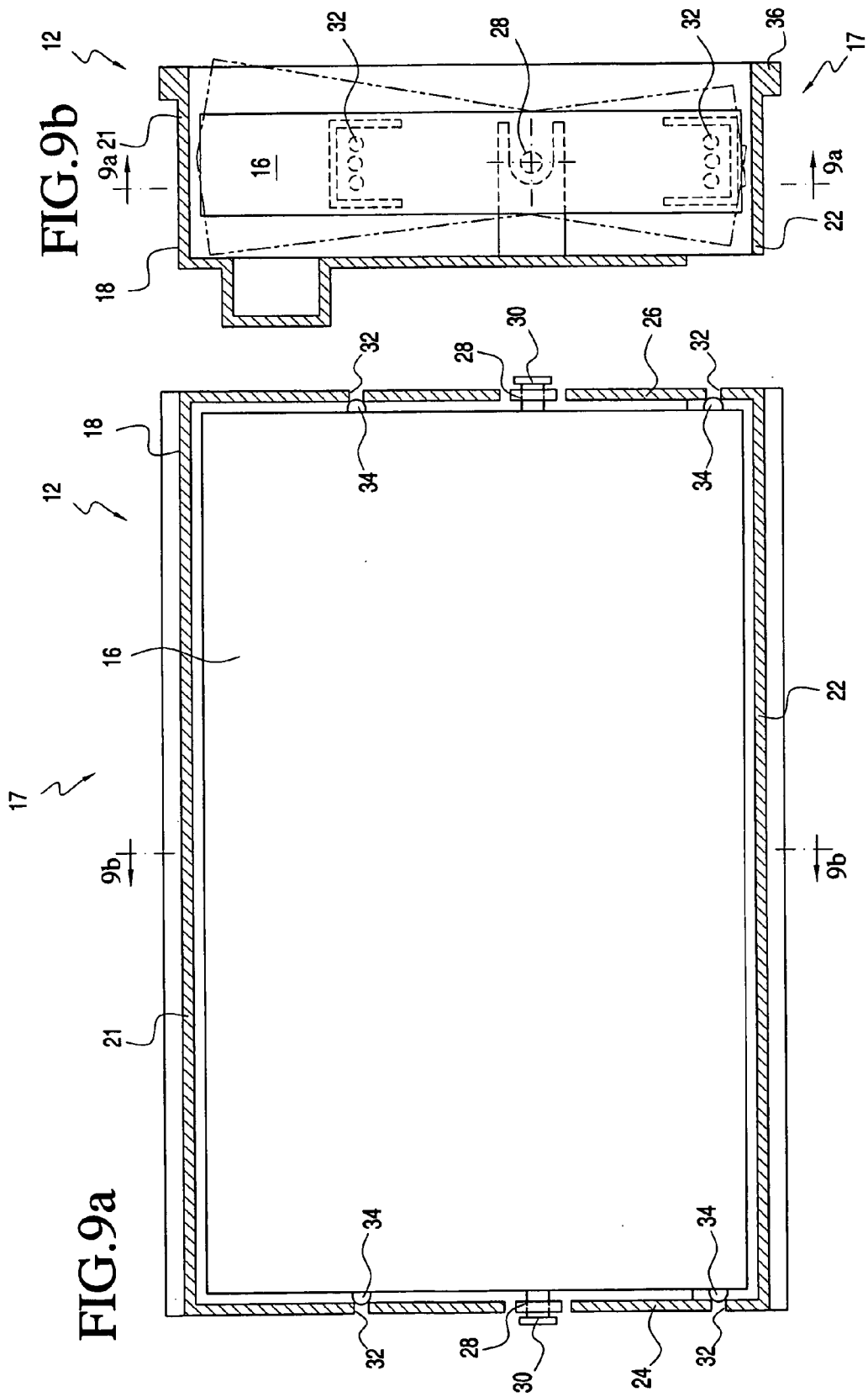
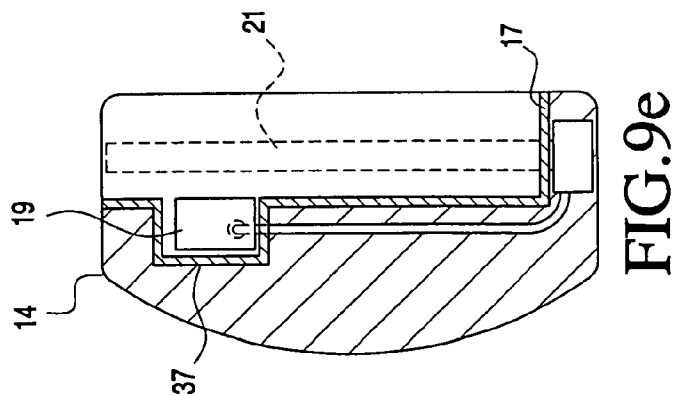
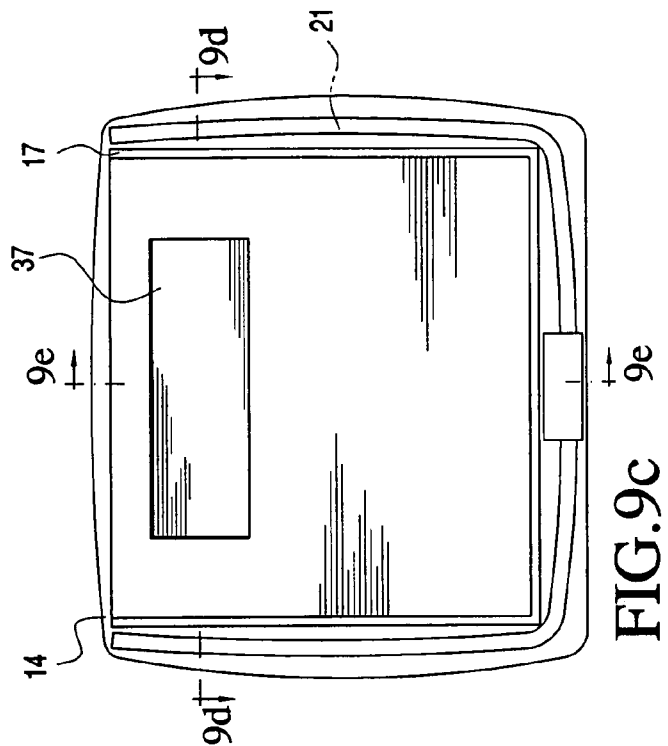
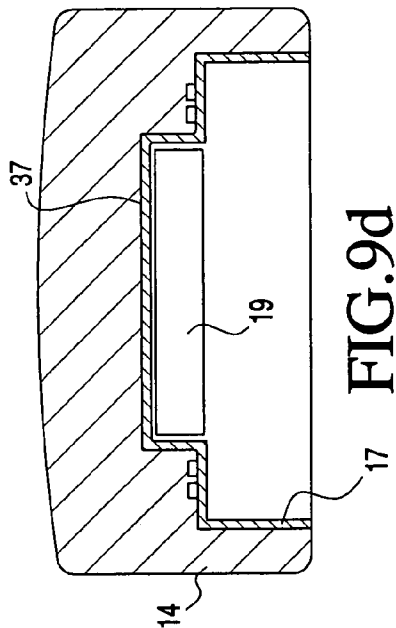

FIG. 8





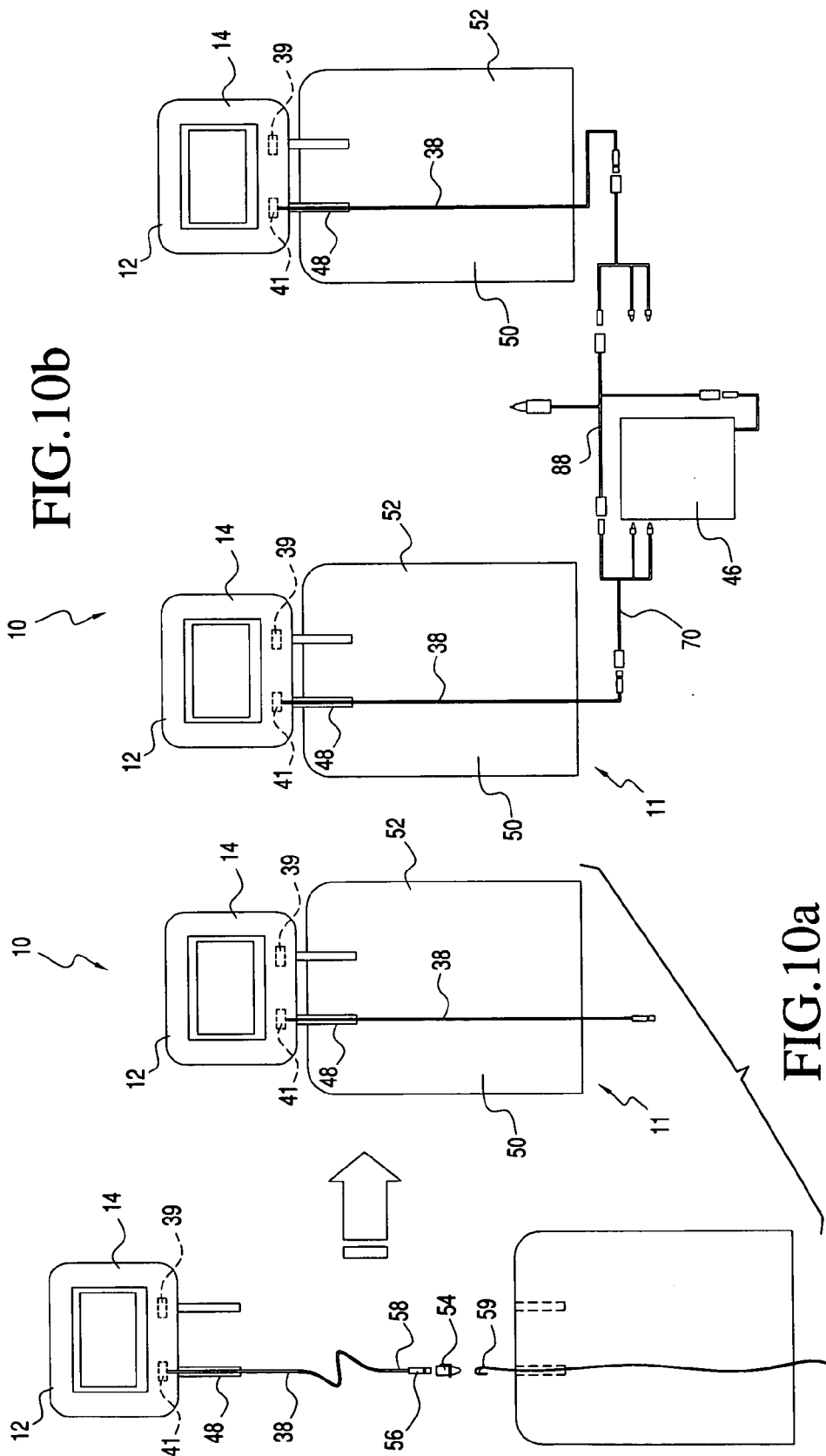

FIG. 10b

FIG. 10a

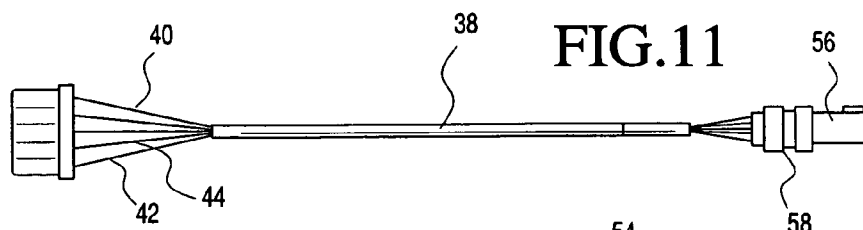

FIG. 11

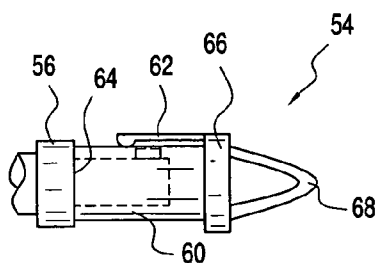

FIG. 12

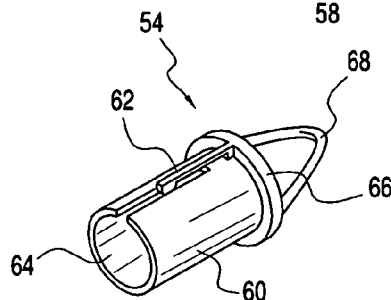

FIG. 12a

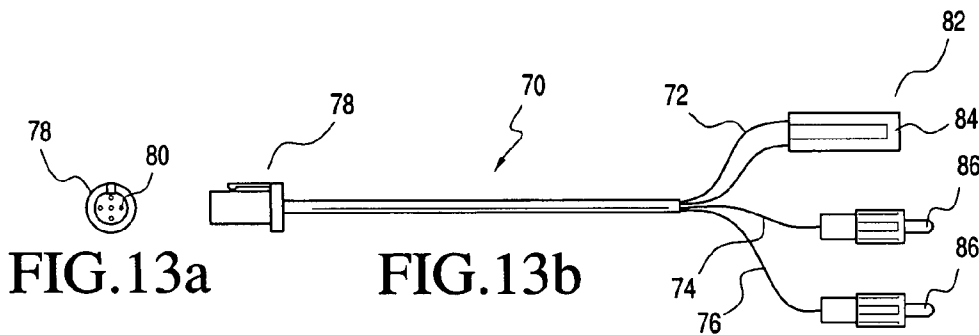

FIG. 13a

FIG. 13b

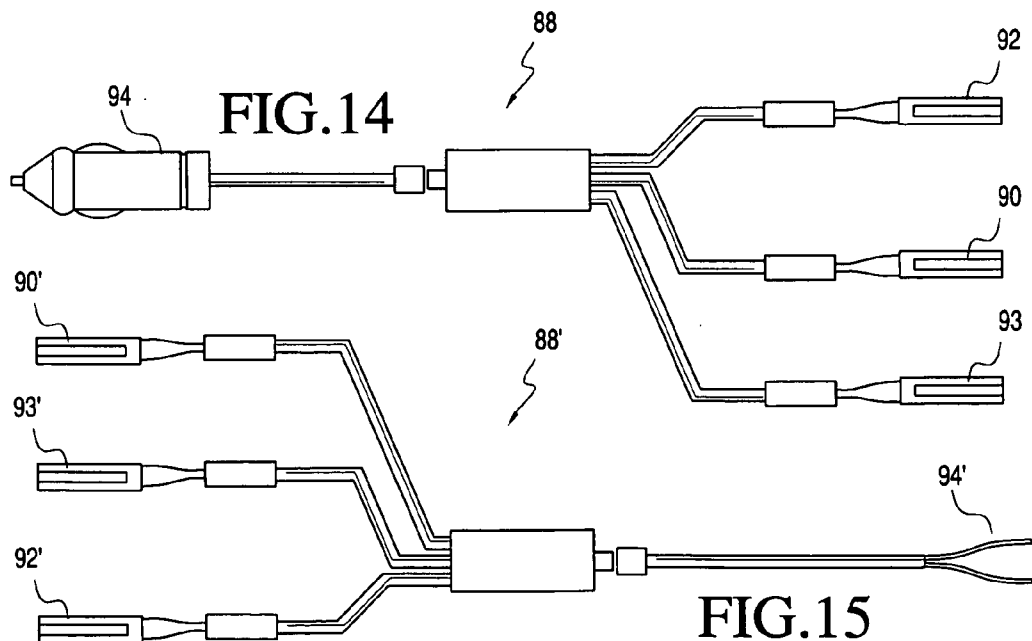

FIG. 14

FIG. 15

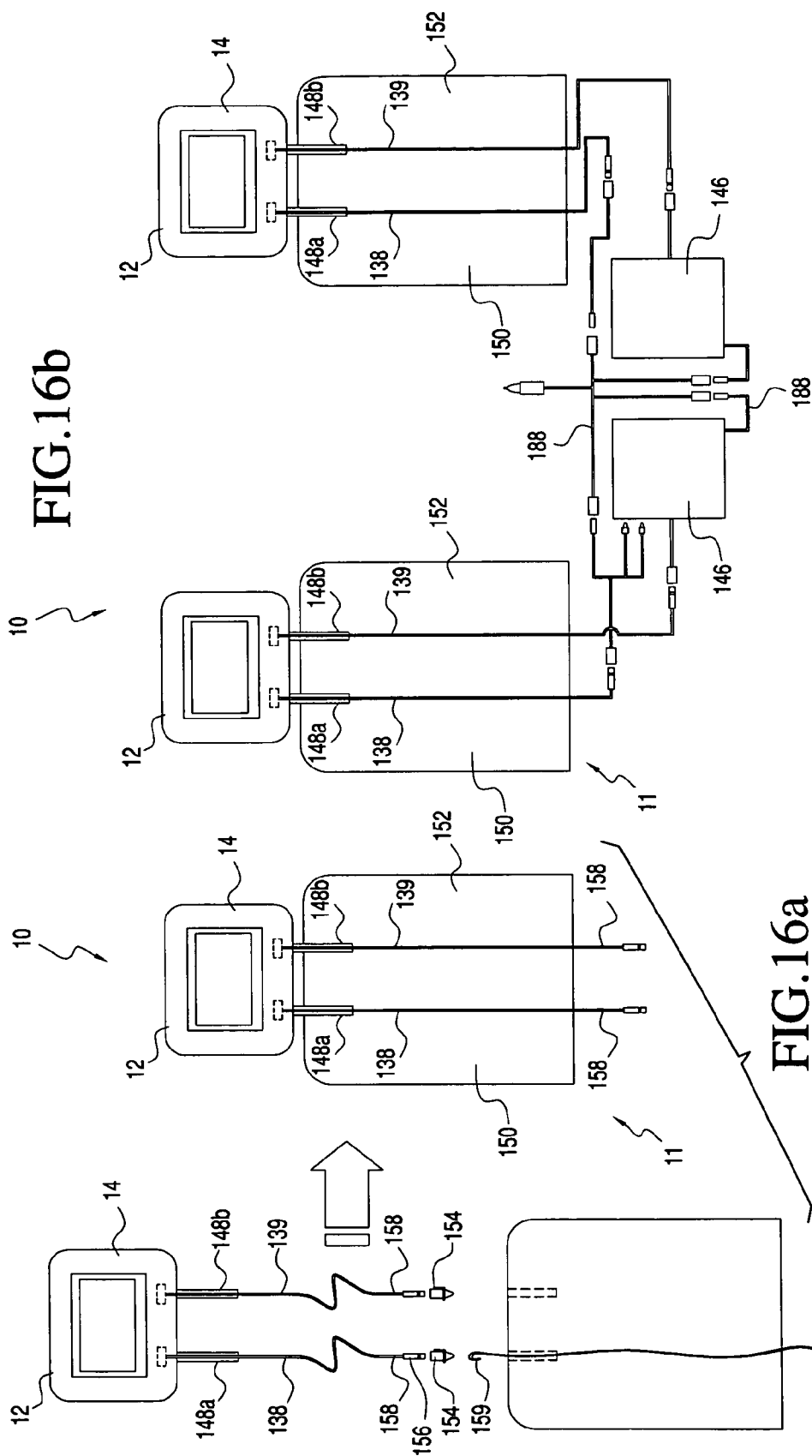
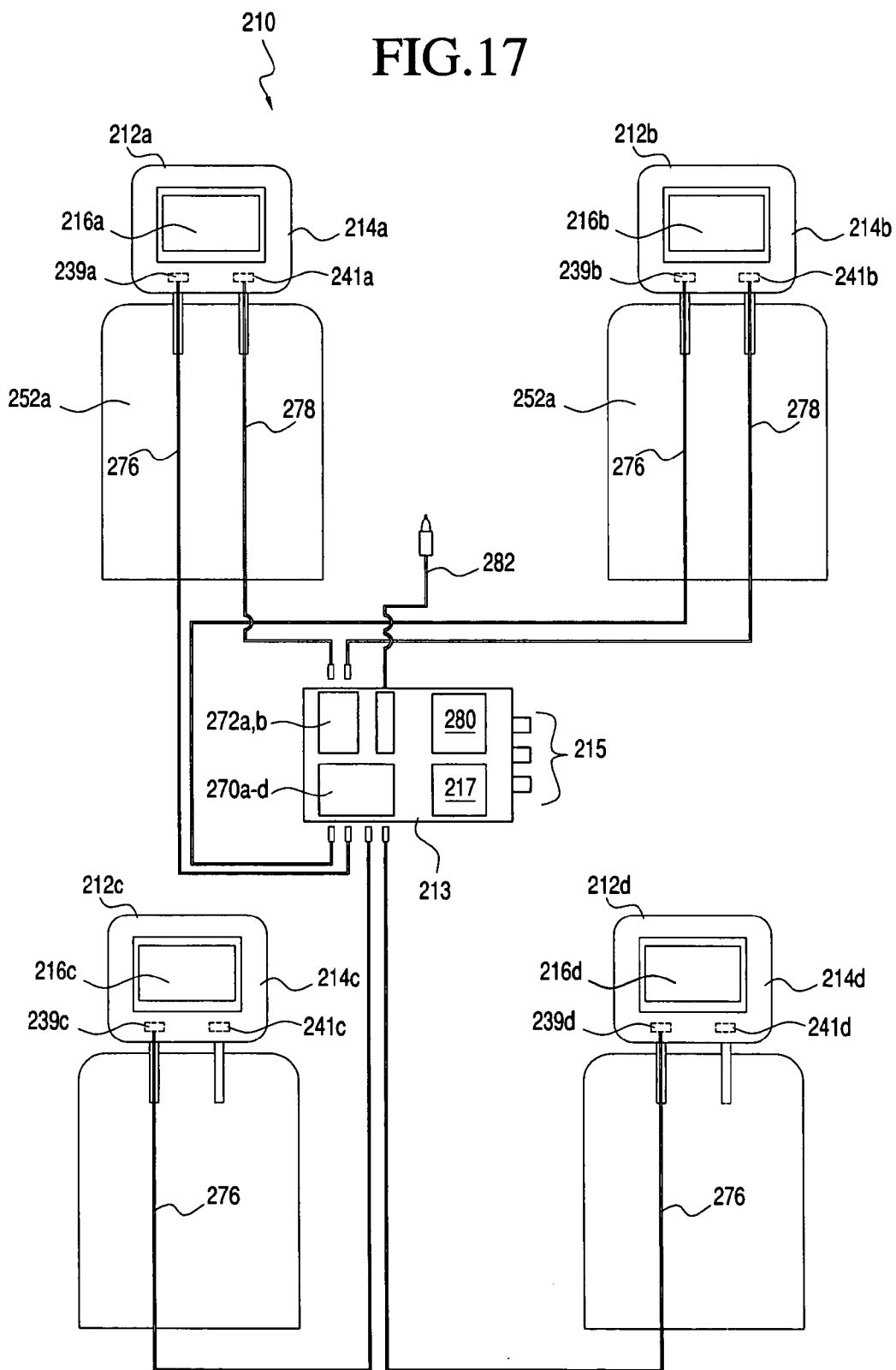

FIG. 16b

FIG. 16a

FIG. 17



AUTOMOBILE ENTERTAINMENT SYSTEM

CROSS REFERENCE TO RELATED APPLICATIONS

[0001] This application is based upon U.S. Provisional Patent Application Nos. 60/517, 862, filed Nov. 7, 2003, entitled "AUTOMOBILE ENTERTAINMENT SYSTEM", 60/534,705, filed Jan. 8, 2004, entitled "AUTOMOBILE ENTERTAINMENT SYSTEM", and 60/571,516, filed on May 17, 2004, entitled "AUTOMOBILE ENTERTAINMENT SYSTEM".

BACKGROUND OF THE INVENTION

[0002] 1. Field of the Invention

[0003] The invention relates to an automobile entertainment system. More particularly, the invention relates to an entertainment system integrating a television receiver and antenna within the headrest of an automobile.

[0004] 2. Description of the Prior Art

[0005] Entertainment systems for automobiles are well known. As such, many advances have been made in the development of entertainment systems that make the otherwise tedious task of driving in an automobile more bearable. In addition to the development of overhead systems pioneered by the present inventor, systems that mount within the headrest of an automobile have also been developed.

[0006] These headrest entertainment systems allow multiple individuals to view a variety of different video screens within the same vehicle. However, and as those skilled in the art will certainly appreciate, it is often desirable to watch television while traveling within the vehicle. Unfortunately, television reception requires receivers and antennas, both of which are cumbersome to employ in an automobile environment. The present invention provides an entertainment system integrating the television receiver and antenna within a headrest for convenient use and efficient installation.

SUMMARY OF THE INVENTION

[0007] It is, therefore, an object of the present invention to provide an automobile entertainment system including a video system mounted within an automobile headrest. The headrest includes a headrest body in which the video system is mounted. The video system also includes an integrated housing supporting a video monitor and a television receiver.

[0008] It is also an object of the present invention to provide an automobile entertainment system wherein the television receiver includes an antenna.

[0009] It is another object of the present invention to provide an automobile entertainment system wherein the antenna is wrapped around the housing.

[0010] It is a further object of the present invention to provide an automobile entertainment system wherein the antenna is substantially U-shaped.

[0011] It is also an object of the present invention to provide an automobile entertainment system wherein the video system further includes a video source.

[0012] It is still another object of the present invention to provide an automobile entertainment system wherein the video source is a DVD player.

[0013] It is yet another object of the present invention to provide an automobile entertainment system wherein the housing includes a recess in which the television receiver is positioned.

[0014] It is also an object of the present invention to provide an automobile entertainment system wherein the housing includes a support frame having a rectangular shell in which the video monitor is pivotally mounted, the support frame including a top wall and a bottom wall connected by a first sidewall and a second sidewall. The first sidewall and second sidewall are respectively provided with bearing slots shaped and dimensioned for receiving lateral posts extending from sides of the video monitor in a manner permitting controlled pivoting of the video monitor within the support frame. Means are also provided for controlling movement of the video monitor within the support frame.

[0015] It is also an object of the present invention to provide a headrest incorporating an automobile entertainment system. The headrest includes a headrest body with a video system mounted therein and the video system includes an integrated housing supporting a video monitor and a television receiver.

[0016] Other objects, advantages and salient features of the invention will become apparent from the following detailed description, which taken in conjunction with the annexed drawings, discloses a preferred, but non-limiting, embodiment of the subject invention.

BRIEF DESCRIPTION OF THE DRAWINGS

[0017] FIGS. 1, 2, 3 and 4 present various views of the video system in accordance with the present invention.

[0018] FIGS. 5, 6, 7 and 8 disclose alternate embodiments of the video system in accordance with the present invention.

[0019] FIGS. 9a and 9b respectively disclose a front view of the video system housing and a cross sectional view of the video system housing along the line B-B in FIG. 9a.

[0020] FIGS. 9c, 9d and 9e present additional views of the present video system housing as it sits within the headrest and without the video monitor.

[0021] FIGS. 10a and 10b are wiring schematics for installation of the present automobile entertainment system in accordance with a first embodiment.

[0022] FIG. 11 is a side view of a multi-wire cable used in directing power and audio signals through the back of a vehicle seat.

[0023] FIG. 12 is a side view of a removable eyelet utilized in drawing the cable shown in FIG. 11 through the back of a vehicle seat.

[0024] FIG. 13 is a side view of a power/audio adaptor for connecting the present system to various remote components.

[0025] FIGS. 14 and 15 disclose alternate embodiments of a power adaptor for connecting the present system to a power supply.

[0026] FIGS. 16a and 16b are wiring schematics for installation of the present automobile entertainment system employing an alternate wiring arrangement.

[0027] FIG. 17 is a schematic of a further embodiment in accordance with the present invention.

DESCRIPTION OF THE PREFERRED EMBODIMENTS

[0028] The detailed embodiment of the present invention is disclosed herein. It should be understood, however, that the disclosed embodiment is merely exemplary of the invention, which may be embodied in various forms. Therefore, the details disclosed herein are not to be interpreted as limiting, but merely as the basis for the claims and as a basis for teaching one skilled in the art how to make and/or use the invention.

[0029] With reference to FIGS. 1 to 15, an automobile entertainment system 10 is disclosed. The automobile entertainment system 10 is composed of a series of video and audio components integrated within an automobile 11. In particular, the entertainment system 10 includes a video system 12 mounted within a standard headrest 14 of an automobile 11. The video system 12 generally includes a video monitor 16 for presenting video content and a video source 20 integrated therewith.

[0030] In accordance with a preferred embodiment of the present invention, the video source is a DVD player 20 coupled to the video monitor 16 for the transmission of video content thereto. That is, the DVD player 20 or other video source is integrated within the same video housing 18 as the video monitor 16. However, those skilled in the art will appreciate that the video source may take a variety of forms without departing from the spirit of the present invention; for example, and not limited to, satellite video systems and Bluetooth wireless based systems.

[0031] The video system 12 also includes an associated housing 17 with a support frame 18. The video system 12 is mounted along the rear portion of the headrest 14 such that an individual sitting in the rear seat of the automobile 11 may watch the material presented on the video monitor 16 without disturbing the driver of the automobile 11.

[0032] The video monitor 16, DVD player 20 and associated control components are mounted within the housing 17. As those skilled in the art will certainly appreciate, the video monitor 16 is mounted for viewing via an opening in the housing 17. With regard to the DVD player 20, it is integrally molded within the housing 17 and positioned for insertion of the DVDs behind the video monitor 16. By mounting the DVD player 20 in this way, a stable structure is developed that is well adapted for the automobile environment.

[0033] While the DVD player 20 is disclosed as being a slot-loaded design with insertion behind the video monitor, the DVD player could take a variety of other forms while still being integrated with the video monitor 16. With reference to FIGS. 5 and 6, the DVD player 116 may be positioned beneath the pivotally mounted video monitor 115. With reference to FIG. 7, the DVD player 216 may be integrated with the video monitor 215 and facilitate access via a side loading slot 217. Referring to FIG. 8, the DVD player 316 is integrated with the underside of the video

monitor 315 and the DVD is snapped into DVD player 316 when the monitor is pivoted upward. In addition, the DVD player may be designed with a built in TV tuner for providing the user with a choice of video sources. The DVD player may also be provided remotely from the video monitor and housing without departing from the spirit of the present invention.

[0034] With reference to FIGS. 9a and 9b, the housing 17 for the present video system is disclosed. The housing 17 includes a support frame 18 in which the video monitor 16 is pivotally mounted. More specifically, the support frame 18 is a generally rectangular shell in which the video monitor 16 is mounted. The support frame 18 includes a top wall 21 and a bottom wall 22 connected by a first and second sidewalls 24, 26.

[0035] The first and second sidewalls 24, 26 are respectively provided with bearing slots 28 shaped and dimensioned for receiving lateral posts 30 extending from the sides of the video monitor 16. In this way, the lateral posts 30 are mounted within the bearing slots 28 permitting controlled pivoting of the video monitor 16 within the support frame 18.

[0036] The controlled movement of the video monitor 16 within the support frame 18 is facilitated by the provision of selectively engageable recesses 32 and detents 34 respectively formed on the support frame 18 and the video monitor 16. The detents 34 are shaped and dimensioned for engagement with the various recesses 32 as the video monitor 16 is pivoted relative to the support frame 18. More specifically, the detents 34 interact with the recesses 32 to control movement of the video monitor 16 by creating predetermined stopping points. As those skilled in the art will certainly appreciate, the support frame 18 includes an outer flange 36 facilitating attachment of the video system 12 to the headrest 14 of an automobile 11.

[0037] In addition, in accordance with a preferred embodiment, a broadcast television receiver 19 is integrated with the video monitor 16 and/or the headrest 14. More particularly, and with reference to FIGS. 9c, 9d and 9e, the support frame 18 of the housing is provided with a rear recess 37 shaped and dimensioned for receiving a television receiver 19. The television receiver may, therefore, be wired for use in conjunction with the video monitor 16 in a manner known to those skilled in the art.

[0038] The television receiver 19 is further provided with an antenna 21. The antenna 21 is electrically connected to the television receiver 19 for the transmission of over-the-air signals. The antenna 21 is substantially U-shaped and is wrapped about the outer surface of the support frame 18. While a U-shaped antenna wrapped about the support frame is disclosed in accordance with a preferred embodiment of the present invention, the antenna may be oriented within a variety of locations within the headrest without departing from the spirit of the present invention.

[0039] As briefly mentioned above, the video system 12 is mounted within the headrest 14. As those skilled in the art will readily appreciate, the video system 12 is provided with inputs 39 and outputs 41 for audio and video. With reference to the embodiment disclosed in FIG. 10, a multi-wire cable 38 extends from the output of 41 the video system 12. The wires making up the multi-wire cable 38 include those for a

power supply **40** and the left and right audio outputs **42, 44** used in providing audio to an alternate audio system, for example, a wireless RF transmitter **46** as will be discussed below in greater detail. Referring to **FIG. 10**, the video system **12** is electrically connected to the remainder of the automobile **11** and a wireless RF transmitter **46** via electrical communication lines extending through the extension arm **48** of the headrest **14** and the back **50** of the vehicle seat **52**. For example, and as will be discussed below in substantial detail, a power source wire **40** and audio output wires **42, 44** are respectively connected to the video system **12** in accordance with a preferred embodiment of the present invention.

[0040] In order to facilitate ease of installation, and with reference to **FIGS. 10 and 11**, the multiple wires required for the power source **40** and audio outputs **42, 44** are maintained within a single multi-wire cable **38**. The multiple wires are passed through a single extension arm **48** of the headrest **14** with the chosen extension arm **48** functioning as a conduit for running the multi-wire cable **38** from the video system **12** to the remainder of the automobile **11**.

[0041] Referring to **FIGS. 10 and 12**, the passage of the multi-wire cable **38** through the headrest extension arm **48** and the back **50** of the vehicle seat **52** is facilitated by the provision of a selectively removable eyelet **54** coupled to the connector shroud **56** at the distal end **58** of the multi-wire cable **38** (for example, supporting **2 to 10** wires). The provision of the eyelet **54** allows the connector shroud **56** to be gripped and pulled through the extension arm **48** and the back **50** of the vehicle seat **52** through utilization of a traditional "wire puller"**59** used by electricians to pull wires through walls and other confined spaces.

[0042] Passage of the connector shroud **56** through the extension arm **48** and the back **50** of the vehicle seat **52** is further enhanced by the shape of the connector shroud **56**. More particularly, the connector shroud **56** is cylindrical and is shaped and dimensioned to readily fit within the extension arm **48** of a conventional headrest **44**. As will be discussed below in greater detail, the connector shroud **56** houses a plurality of connector pins **80** used in linking the video system to other components of the present invention.

[0043] The eyelet **54** includes a cylindrical housing **60** shaped and dimensioned to fit over the connector shroud **56**. The eyelet **54** is selectively secured to the shroud **56** via a conventional lock arm **62** used in the secure connection of cable connectors. The housing **62** includes an open first end **64** that is shaped to receive the connector shroud **56** and a second end **66** having a closed loop **68** extending therefrom. The closed loop **68** is shaped and dimensioned for engagement with the "wire puller"**59**. In this way, the eyelet **54** is secured to the connector shroud **56** at the distal end **58** of the multi-wire cable **38** and both are drawn through the back **50** of the vehicle seat **52** by the "wire puller"**59**. Once the distal end **58** of the multi-wire cable **38** is pulled through the vehicle seat **52**, the eyelet **54** is removed from the connector shroud **56** and the cable **38** is ready for attachment to various components as described below in greater detail. Although a closed loop is disclosed for attachment to the wire puller in accordance with a preferred embodiment of the present invention, other structural coupling members, for example, hook, snap, open loop, etc. could be used without departing from the spirit of the present invention.

[0044] Once the distal end **58** of the multi-wire cable **38** is pulled through the back **50** of the vehicle seat **52**, various

adaptors may be used to couple it to the appropriate power, video and audio sources. With reference to **FIG. 13**, and in accordance with a preferred embodiment of the present invention a power/audio adaptor **70** including wiring for power transmission **72**, left audio transmission **74** and right audio transmission **76** is shown. The proximal end **78** of the adaptor **70** is provided with male pins **80** for connection with the female connection structures (not shown) provided at the distal end **58** of the multi-wire cable **38**. The distal end **82** of the adaptor **70** includes a power connection **84** and standard RCA connections **86** for the audio signal.

[0045] **FIGS. 14 and 15** disclose further power adaptors **88, 88'** for connection to the power connection **84** of the power/audio adaptor **70** shown in **FIG. 13**. In particular, **FIG. 14** discloses a power adaptor **88** for tapping into a power source via a DC "cigarette lighter", or power adaptor outlets, provided in most vehicles and **FIG. 15** discloses a power adaptor **88'** for direct connection to the vehicle power source (not shown).

[0046] The power adaptor **88** shown in **FIG. 14** includes first and second connectors **90, 92** (potentially a third connector **93** for attachment to the power input of the RF transmitter **46**) shaped and dimensioned for engagement with the power connectors **84** of the power/audio adaptors **70** of the two video systems **12** installed in adjacent headrests **14**. The power adaptor **88** also includes a conventional power plug **94** at the opposite end for plugging into a power adaptor outlet. As such, multiple systems **12** may be connected to a single power source.

[0047] The power adaptor **88'** shown in **FIG. 15** includes first and second connectors **90', 92'** (potentially a third connector **93'** for attachment to the power input of the RF transmitter **46**) shaped and dimensioned for engagement with the power connectors **84** of the power/audio adaptors **70** of the two video systems **12** installed in adjacent headrests **14**. The power adaptor **88'** also includes a conventional pair of electrical lines **94'** at the opposite end for connection to the automobile power supply. As such, multiple systems **12** may be connected to a single power source.

[0048] More particularly, and in accordance with preferred embodiments of the present invention, the power source wire **40** may run either directly from the main automobile power source (see **FIG. 15**) or via the power adaptor outlet via a power adaptor outlet (see **FIG. 14**).

[0049] As those skilled in the art will certainly appreciate, the audio portion of the source may be transmitted to users in a variety of ways without departing from the spirit of the present invention. For example, and in accordance with a preferred embodiment of the present invention, the video monitors **16** are provided with a direct audio input **60** allowing users to simply plug-in their headphones to listen to the audio content of the source being transmitted by the video monitor **16**.

[0050] In accordance with still a further feature of the present invention, the audio source being generated by the DVD player **20** is transmitted to a wireless RF transmitter **46** via the audio output wires **40, 42** discussed above, which transmits the audio content at a frequency received by the radio system of the automobile **11** or wireless headphones. In this way, the users of the present system need only tune to a predetermined radio frequency to listen to the audio

content through the traditional speaker system of the automobile 11. Further, and in accordance with yet a further embodiment of the present invention, the audio output wires 40, 42 of the DVD player 20 may be hardwired to the radio of the automobile 11 for listening over the stereo system of the automobile 11. As those skilled in the art will certainly appreciate, it is further contemplated the audio output wires 40, 42 may be connected to a variety of other sound transducers which convert the audio signals to audible sounds for listening by those watching the video monitor without departing from the spirit of the present invention. As mentioned above, where headphones are utilized the audio outputs will preferably be connected to a wireless transmitter for use in conjunction with wireless headphones. Optionally, it is contemplated the audio outputs may be connected to a switch box allowing for selective use of both the audio system of the automobile and/or an audio jack (for attachment with a headphone). As those skilled in the art will certainly appreciate, the system will also include ports for the attachment of video games and other video sources.

[0051] Control of the DVD player 20 is facilitated by the provision of control buttons (not shown) along the outer surface of the DVD player. The control buttons are conventional in the art and may take a variety of forms. In addition to the provision of manual control buttons, the DVD player may further include a remote control (not shown) such that an individual need not actually touch the DVD player 20 or video system 12 to control the video content or the volume generated by the video system 12. Once again, and as those skilled in the art will certainly appreciate, a variety of remote control systems may be utilized without departing from the spirit of the present invention.

[0052] The versatility of the present system may be further enhanced by the provision of different cables for the power and the audio output. For example, and with reference to FIG. 16, separate cables 138, 139 extend through the respective support arms 148a, 148b of the headrest 14. As with the prior embodiment, the passage of the power cable 138 and the audio output cable 139 through the headrest extension arms 148a, 148b and the back 150 of the vehicle seat 152 is facilitated by the provision of an eyelet 154 with the connector shroud 156 at the distal end 158 of the cables 138, 139. The provision of the eyelet 154 allows for the connector shroud 156 to be gripped and pulled through the extension arms 148a, 148b and the back 150 of the vehicle seat 152 through utilization of a traditional "wire puller" 159 used by electricians to pull wires through walls and other confined spaces.

[0053] As mentioned above, once the distal end 158 of the power cable 138 and audio output cable 139 are pulled through the back 150 of the vehicle seat 152, various adaptors may be used to couple it to the appropriate power and audio sources. In accordance with this embodiment, it is preferred that the audio output cable 139 be directly connected to a wireless RF transmitter 146, while either of the power adaptors 188, 188' disclosed in FIGS. 14 and 15 may be used for coupling the video system 112 to a source of power.

[0054] As shown in FIG. 16, the embodiment provides for two RF transmitters 146 making it possible for individuals sitting next to each other to watch different videos and listen to the different videos through wireless headphones.

[0055] In accordance with yet a further embodiment and with reference to FIG. 17, each video system 212a-d is

provided with an input 239a-d and an output 241a-d providing the ability to input and output video and audio signals for use in conjunction with other video systems found within the same automobile. As those skilled in the art will certainly appreciate, there are times when people sitting within an automobile will wish to watch the same thing on different video systems. In accordance with a preferred embodiment of the present, the plurality of video systems 212a-d within the automobile may be linked. As such, the content of a DVD playing in one video system 212a-d may be transferred to the other video system(s) 212a-d such that people viewing other video systems 212a-d installed within an automobile can simultaneously watch and listen to the same video content. The use of the switching system described below does not negate the ability of an automobile passenger to individually watch a video without sharing via the central switching assembly 213.

[0056] With this mind and with reference to FIG. 17, an entertainment system 210 employing four linked video systems 212a-d is disclosed. The entertainment system 210 includes a central switching assembly 213 to which the various video systems 212a-d are linked for outputting signals to and receiving signals from. The central switching assembly 213 receives and transmits video and audio content in a controlled manner such that the same audio and video content is selectively provided for individuals viewing different monitors 216a-d while sitting in an automobile. This is accomplished by linking the audio and video inputs 239a-d and outputs 241a-d from the various video systems 212a-d installed with a vehicle and selectively transmitting the desired content to the different video systems 212a-d. The central switching assembly 213 also includes a separate audio/video input 215 (for example, RCA plugs) for receiving video content from a remote source for transmission to the various video systems 212a-d connected thereto.

[0057] More specifically, the central switching assembly 213 is provided with the ability to receive audio and video outputs from the various video systems 212a-d connected thereto and transmit, in a predetermined manner under the control of the vehicle operator, video and audio inputs to the various video systems 212a-d connected thereto. In addition, to providing for the ready transfer of information between the various video systems 212a-d connected thereto, the central switching assembly 213 is also provided with a wireless FM transmitter 217. The transmitter 217 allows for the transmission of audio signals to the automobile radio (not shown) for listening on a predetermined frequency via the automobile stereo. In particular, and as those skilled in the art will certainly appreciate, the transmitter 217 is designed to transmit audio signals on a predetermined frequency receivable by the vehicle radio. The signal is received by the vehicle radio, demodulated and played over the vehicle stereo. The central switching assembly 213 may also be provided with a TV tuner, a modulator and/or other wireless transmitters.

[0058] With regard to the system disclosed with reference to FIG. 17, a first video system 212a, a second video system 212b, a third video system 212c and a fourth video system 212d are provided. The first and second video systems 212a, 212b are positioned within the respective headrests 214a, 214b of the front vehicle seats 252a, 252b, while the third and fourth video systems 212c, 212d are positioned within

the respective headrests **214c**, **214d** of the second row of seating found in the automobile.

[0059] In accordance with the disclosed configuration, the first and second video systems **212a**, **212b** are coupled to both audio/video inputs **270a**, **270b** and audio/video outputs **272a**, **272b**, while the third and fourth video systems are only connected with audio/video inputs **270c**, **270d** coming from the central switching assembly **213**. As with the various embodiments described above, the cables coupling the first, second, third and fourth video systems **212a-d** to the central switching assembly **213** are passed through the extension arm of the headrest **214a-d** and down the back of the vehicle seat **252a-d**. While a specific configuration is disclosed in accordance with a preferred embodiment of the present invention, the input and output configurations may be readily varied without departing from the spirit of the present invention.

[0060] With reference to the first and second video systems **212a-d**, each includes two six-pin cables **276**, **278** extending therefrom, one for the input side **239a**, **239b** of the system and the other for the output side **241a**, **241b** of the video system **212a**, **212b**. Each of the six-pin cables **276**, **278** is passed through a respective extension arm of the headrest **214a**, **214b**. With reference to the output side **241a**, **241b** of the video system **212a**, **212b**, the six-pin cable **278** includes wiring for power, right and left audio output signals, and a video output signal. In this way, the first and second video systems are able to readily transfer video and audio information to the central switching assembly **213** for sharing with the remaining video systems **212a-d** connected thereto.

[0061] As mentioned above, each of the first, second, third and fourth video systems **212a-d** include an input cable **276** for receiving audio and video signals from the central switching assembly **213**. In accordance with a preferred embodiment of the present invention, each of the input cables **276** is a six-pin cable includes wiring for power, right and left audio input signals, and a video input signal. In this way, the first, second, third and fourth video systems **212a-d** are able to readily receive video and audio information from the central switching assembly **213**.

[0062] With output cables **278** transferring audio and video signals to the central switching assembly **213**, and input cables **276** transferring audio and video signals to the video systems **212a-d**, the central switching assembly **213** includes a central processor **280** programmed to control to the transmission of signals in an efficient manner.

[0063] The power supply **282** for the video systems **212a-d** is run through the central switching assembly **213**. As mentioned above, each of the cables **276**, **278** coupled to the various video systems **212a-d** includes wiring for power transmission. With this in mind, the central switching assembly **213** is linked to a power source **282**, for example, an auxiliary power plug commonly found in vehicles or a direct link to the vehicle power source via cable previously discussed with reference to **FIGS. 14 and 15**, respectively. The power supplied to the central switching assembly **213** is then transferred to the various video systems **212a-d** via the power lines of the six-pin cables **276**, **278** linking the video systems **212a-d** to the central switching assembly **213**.

[0064] Through implementation of the switching system described above, automobile passengers have the choice of

watching individual videos by using the video systems as self contained units or watching the same video through the linking provided via the implementation of the central switching assembly **213**.

[0065] While the preferred embodiments have been shown and described, it will be understood that there is no intent to limit the invention by such disclosure, but rather, is intended to cover all modifications and alternate constructions falling within the spirit and scope of the invention as defined in the appended claims.

1. An automobile entertainment system, comprising:

a video system mounted within an automobile headrest, the headrest including a headrest body in which the video system is mounted;

the video system including an integrated housing supporting a video monitor and a television receiver.

2. The entertainment system according to claim 1, wherein the television receiver includes an antenna.

3. The entertainment system according to claim 2, wherein the antenna is wrapped around the housing.

4. The entertainment system according to claim 3, wherein the antenna is substantially U-shaped.

5. The entertainment system according to claim 1, wherein the video system further includes a video source.

6. The entertainment system according to claim 5, wherein the video source is a DVD player.

7. The entertainment system according to claim 1, wherein the housing includes a recess in which the television receiver is positioned.

8. The entertainment system according to claim 1, wherein the housing includes:

a support frame including a rectangular shell in which the video monitor is pivotally mounted, the support frame includes a top wall and a bottom wall connected by a first sidewall and a second sidewall;

the first sidewall and second sidewall are respectively provided with bearing slots shaped and dimensioned for receiving lateral posts extending from sides of the video monitor in a manner permitting controlled pivoting of the video monitor within the support frame;

and means for controlling movement of the video monitor within the support frame.

9. The entertainment system according to claim 8, wherein the housing includes a recess in which the television receiver is positioned.

10. The entertainment system according to claim 8, wherein the television receiver includes an antenna.

11. A headrest incorporating an automobile entertainment system, comprising:

a headrest body with a video system mounted therein;

the video system including an integrated housing supporting a video monitor and a television receiver.

12. The headrest according to claim 11, wherein the television receiver includes an antenna.

13. The headrest according to claim 12, wherein the antenna is wrapped around the housing.

14. The headrest according to claim 13, wherein the antenna is substantially U-shaped.

15. The headrest according to claim 11, wherein the video system further includes a video source.

16. The headrest according to claim 15, wherein the video source is a DVD player.

17. The headrest according to claim 11, wherein the housing includes a recess in which the television receiver is positioned.

18. The headrest according to claim 11, wherein the housing includes:

a support frame including a rectangular shell in which the video monitor is pivotally mounted, the support frame includes a top wall and a bottom wall connected by a first sidewall and a second sidewall;

the first sidewall and second sidewall are respectively provided with bearing slots shaped and dimensioned

for receiving lateral posts extending from sides of the video monitor in a manner permitting controlled pivoting of the video monitor within the support frame;

and means for controlling movement of the video monitor within the support frame.

19. The headrest according to claim 18, wherein the housing includes a recess in which the television receiver is positioned.

20. The headrest according to claim 18, wherein the television receiver includes an antenna.

* * * * *