



(19) **United States**

(12) **Patent Application Publication**  
**Binnard**

(10) **Pub. No.: US 2003/0085676 A1**

(43) **Pub. Date: May 8, 2003**

(54) **SIX DEGREE OF FREEDOM CONTROL OF PLANAR MOTORS**

(76) Inventor: **Michael Binnard**, Belmont, CA (US)

Correspondence Address:

**David Hill, Esq.**  
**FINNEGAN, HENDERSON, FARABOW,**  
**GARRETT, &**  
**DUNNER, LLP**  
**1300 I. Street, N.W., Suite 700**  
**Washington, DC 20005-3315 (US)**

(21) Appl. No.: **09/892,558**

(22) Filed: **Jun. 28, 2001**

**Publication Classification**

(51) **Int. Cl.<sup>7</sup> ..... H02K 41/00**

(52) **U.S. Cl. .... 318/114**

(57) **ABSTRACT**

A method for controlling and positioning a two-dimensional electric motor in six degrees of freedom is disclosed. The electric motor has a coil array and a magnet array. The method controls the motor in six degrees of freedom. The method includes: determining currents for generating the desired forces in a first, second and third direction, the first and second directions being defined in a plane in which the magnets are disposed and the third direction being generally orthogonal to the first and second directions, determining a resultant torque about the first, second, and third directions that would be generated from applying the determined currents, determining current adjustments to compensate for the resultant torque, and applying a current equal to the sum of the determined currents and the current adjustments to the coils to interact with the magnetic fields of the magnet array. The currents are applied only to the portion of the coil array within the magnetic field of the magnet array, including those coils which are only partially within the magnetic field of the magnet array. The method of the invention may be used in applications such as positioning wafers in semiconductor fabrication.

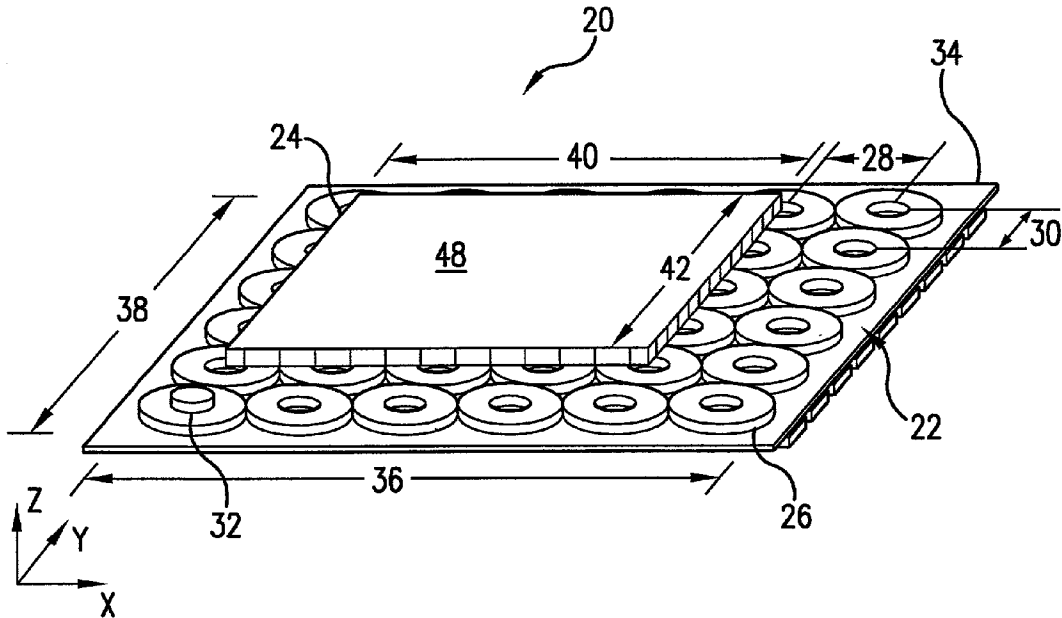

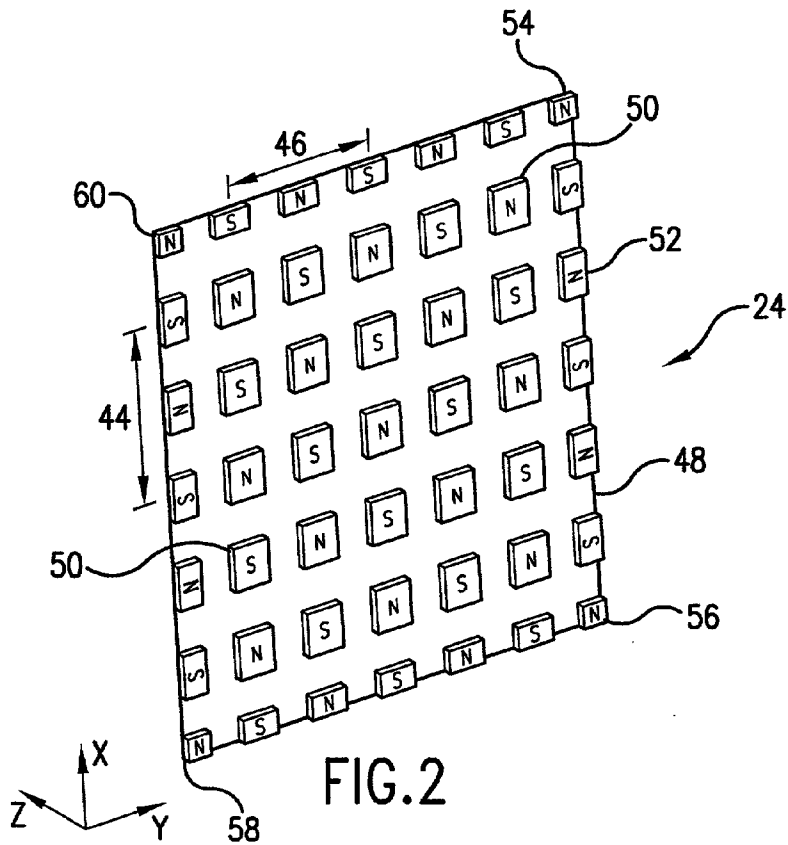
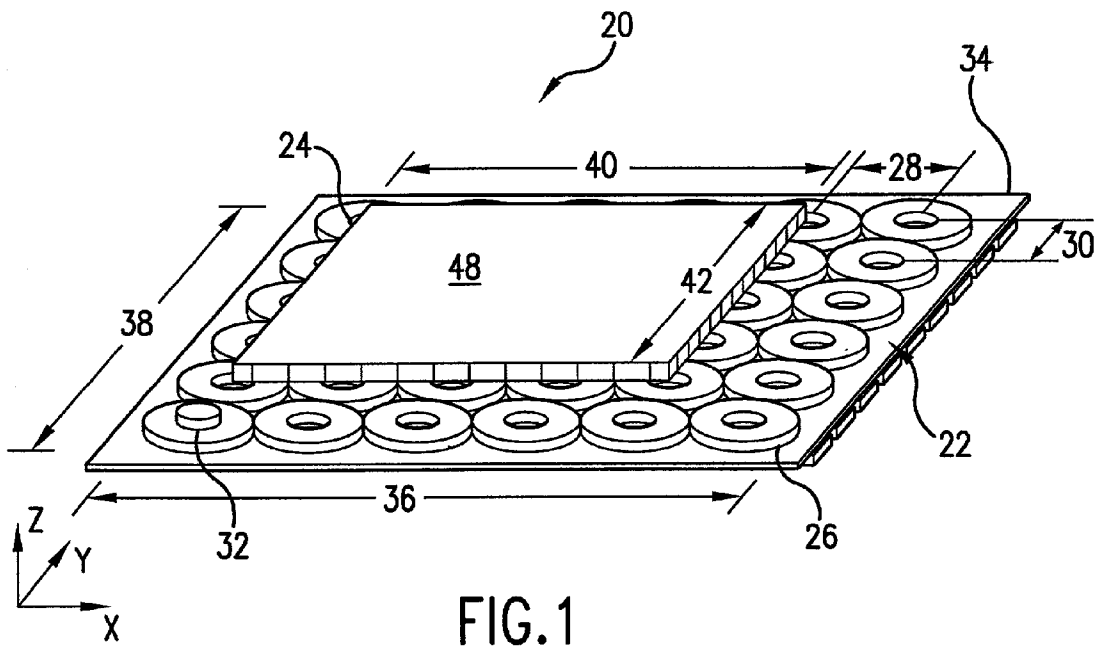

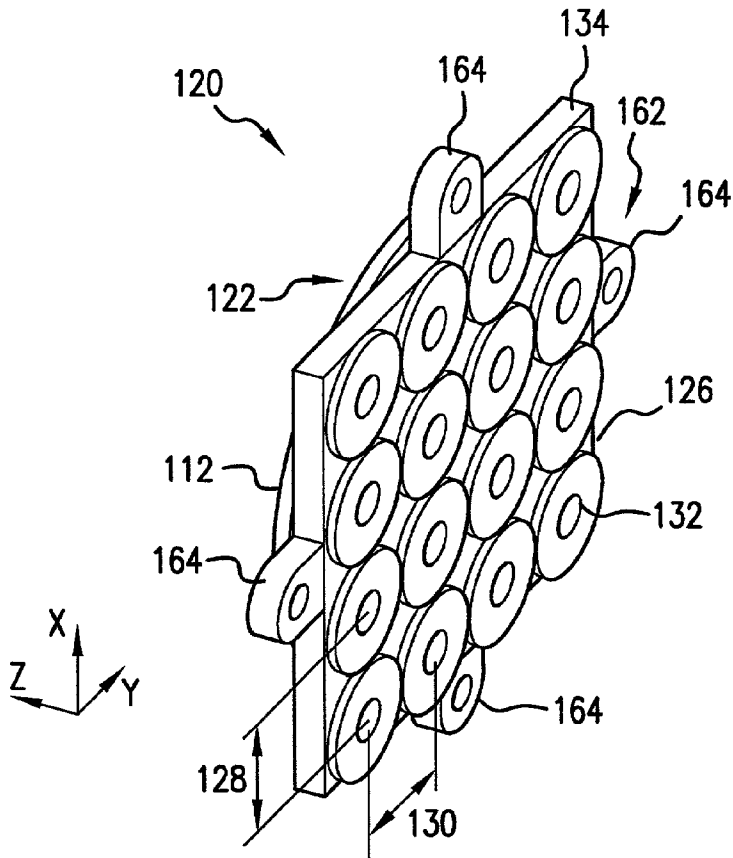

FIG.3

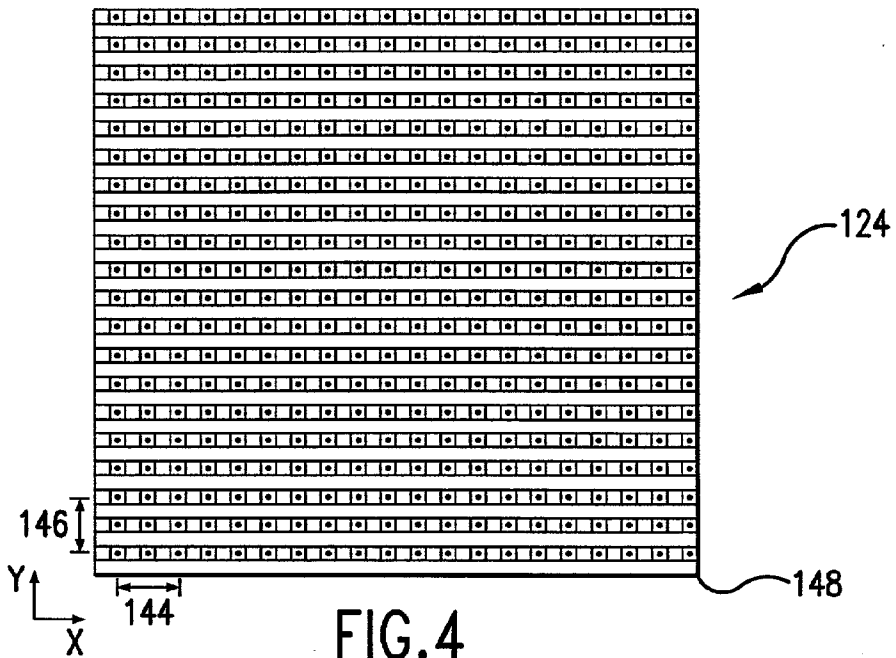

FIG.4

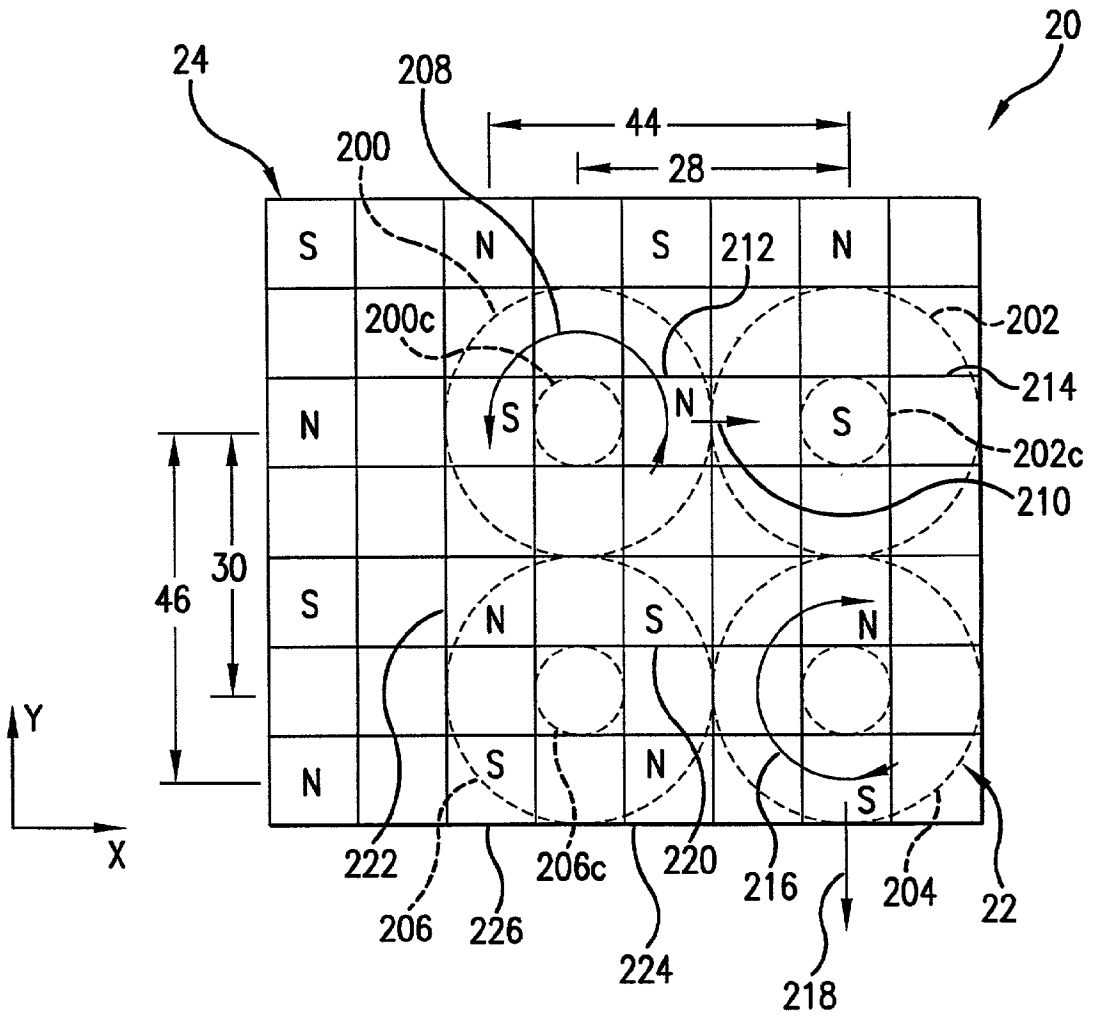

FIG. 5

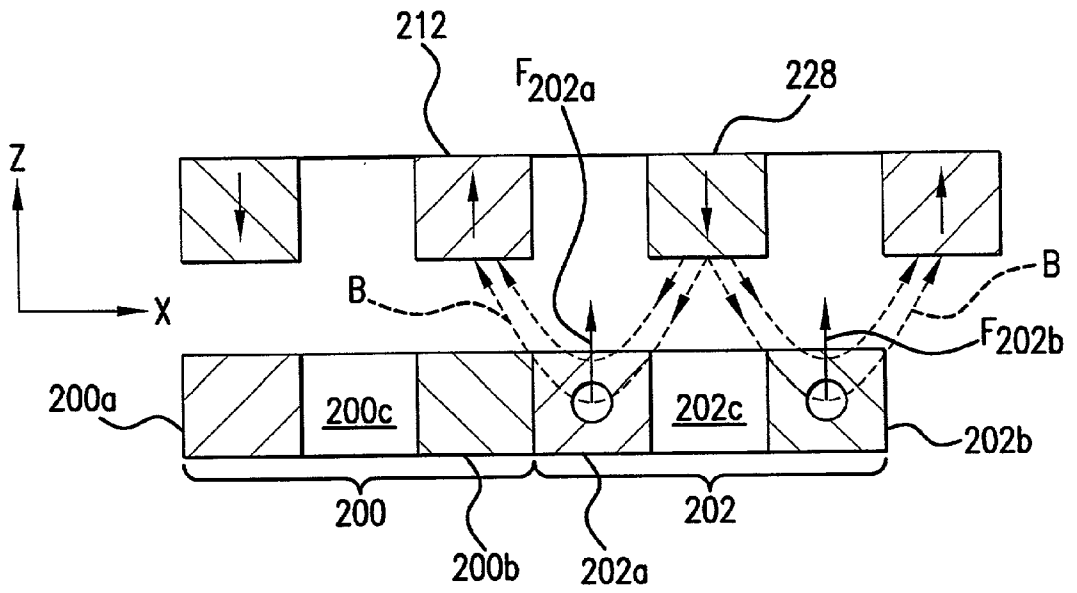

FIG. 6

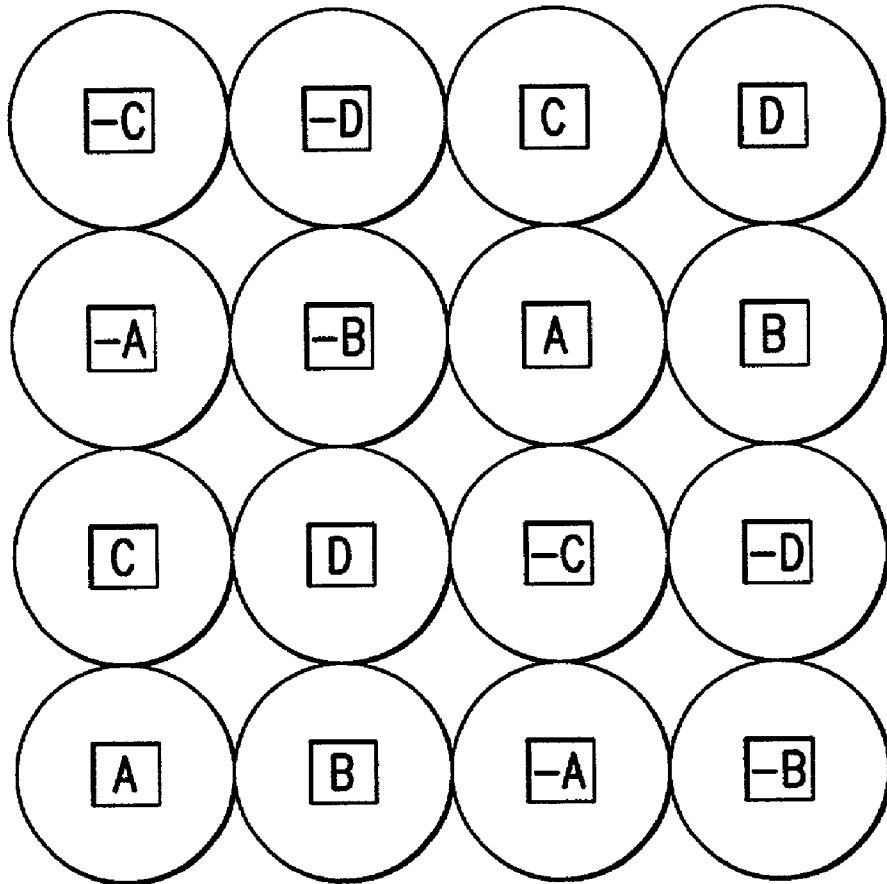

FIG.7

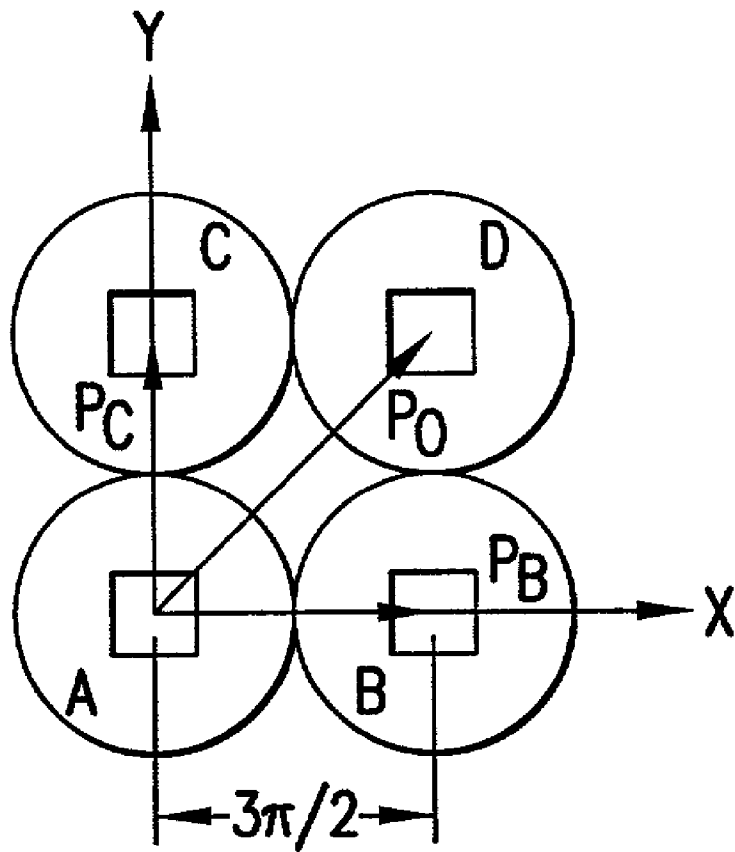

FIG.8

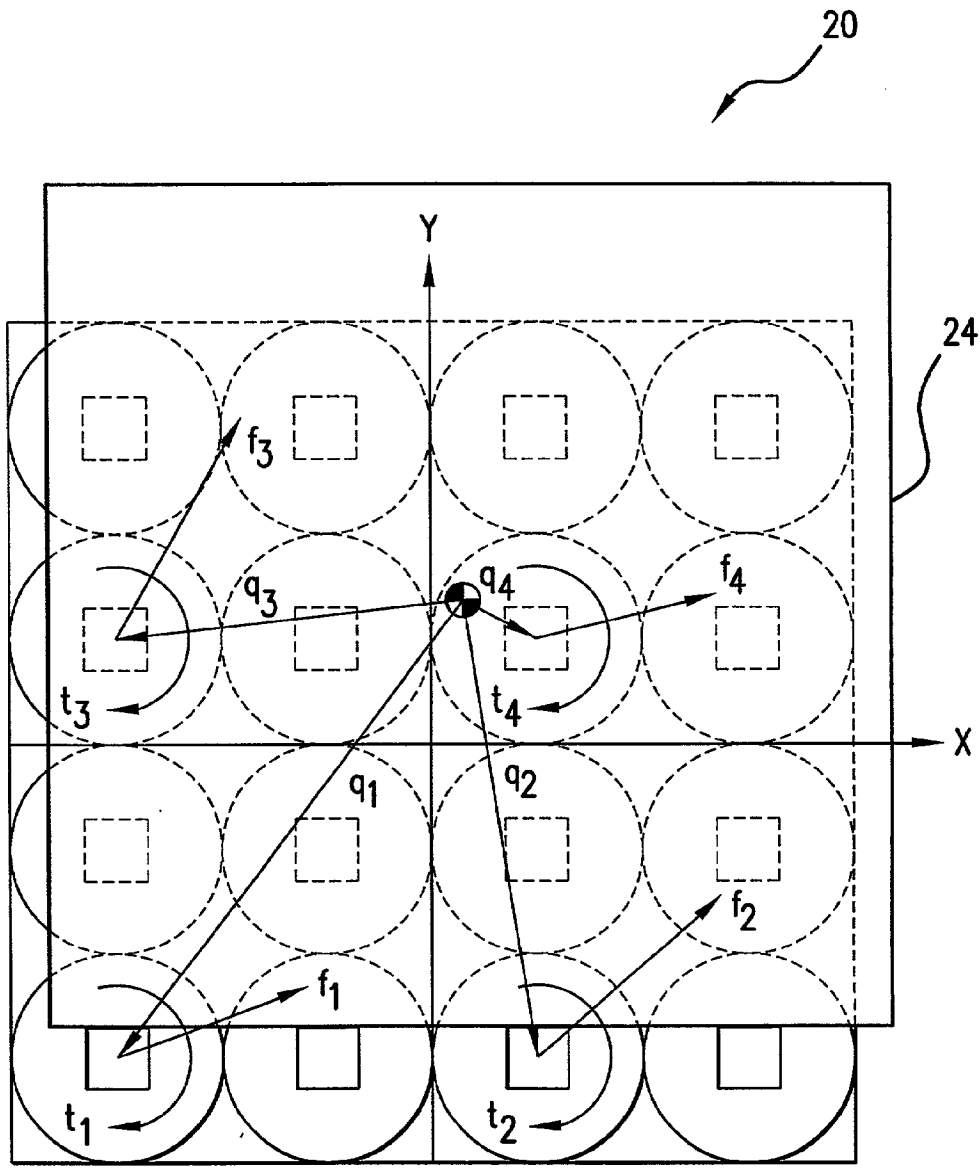

FIG.9A



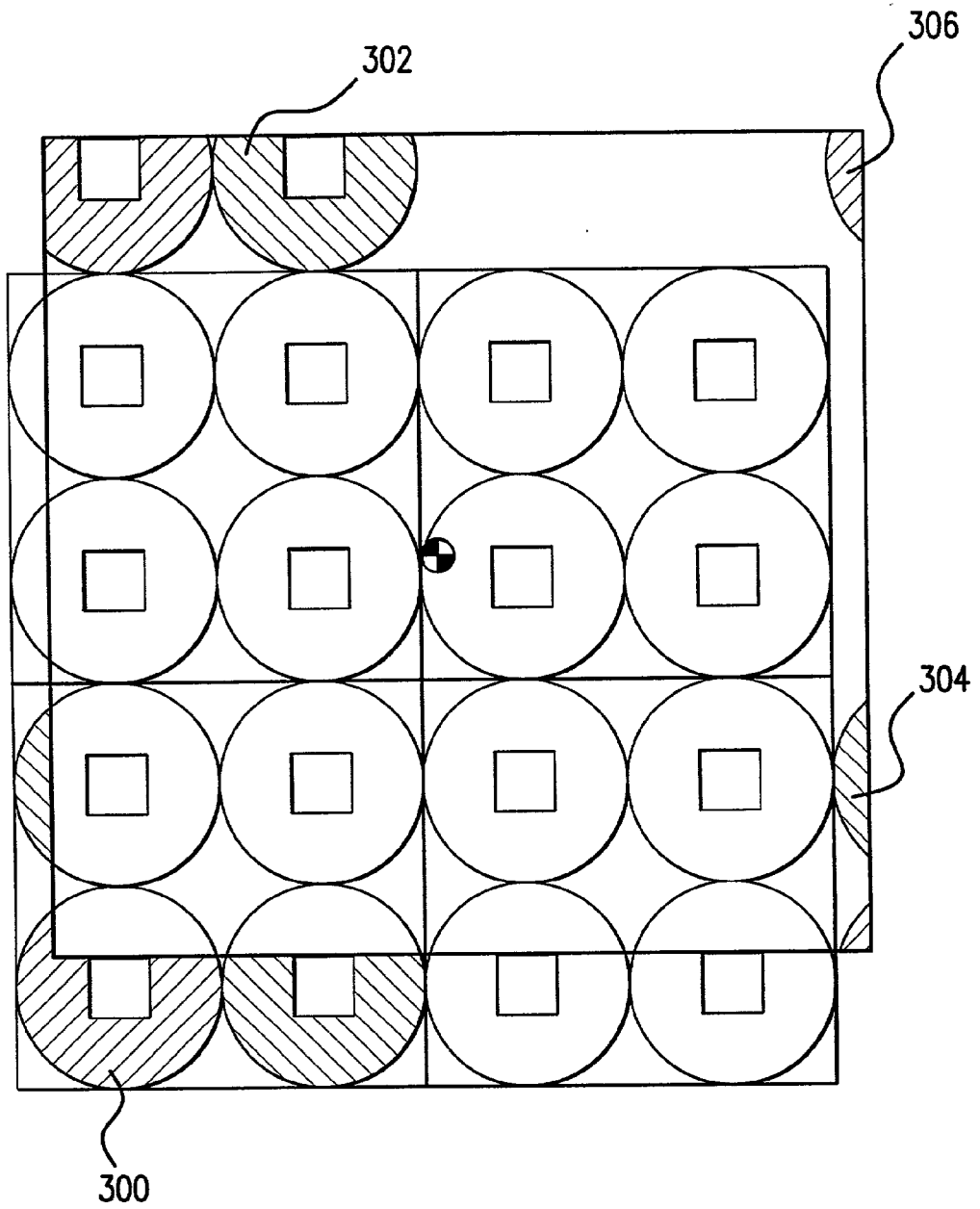

FIG. 9B

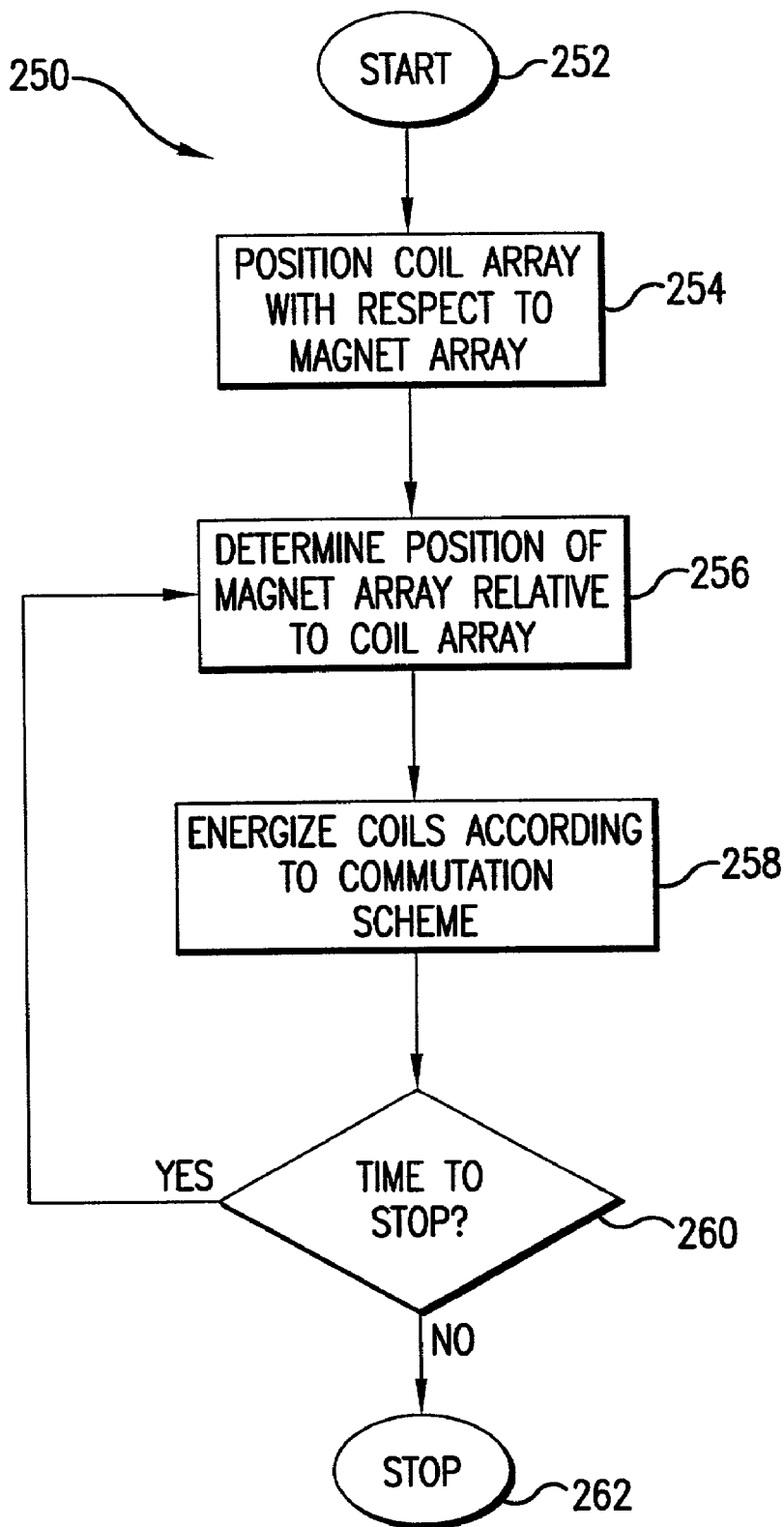

FIG. 10

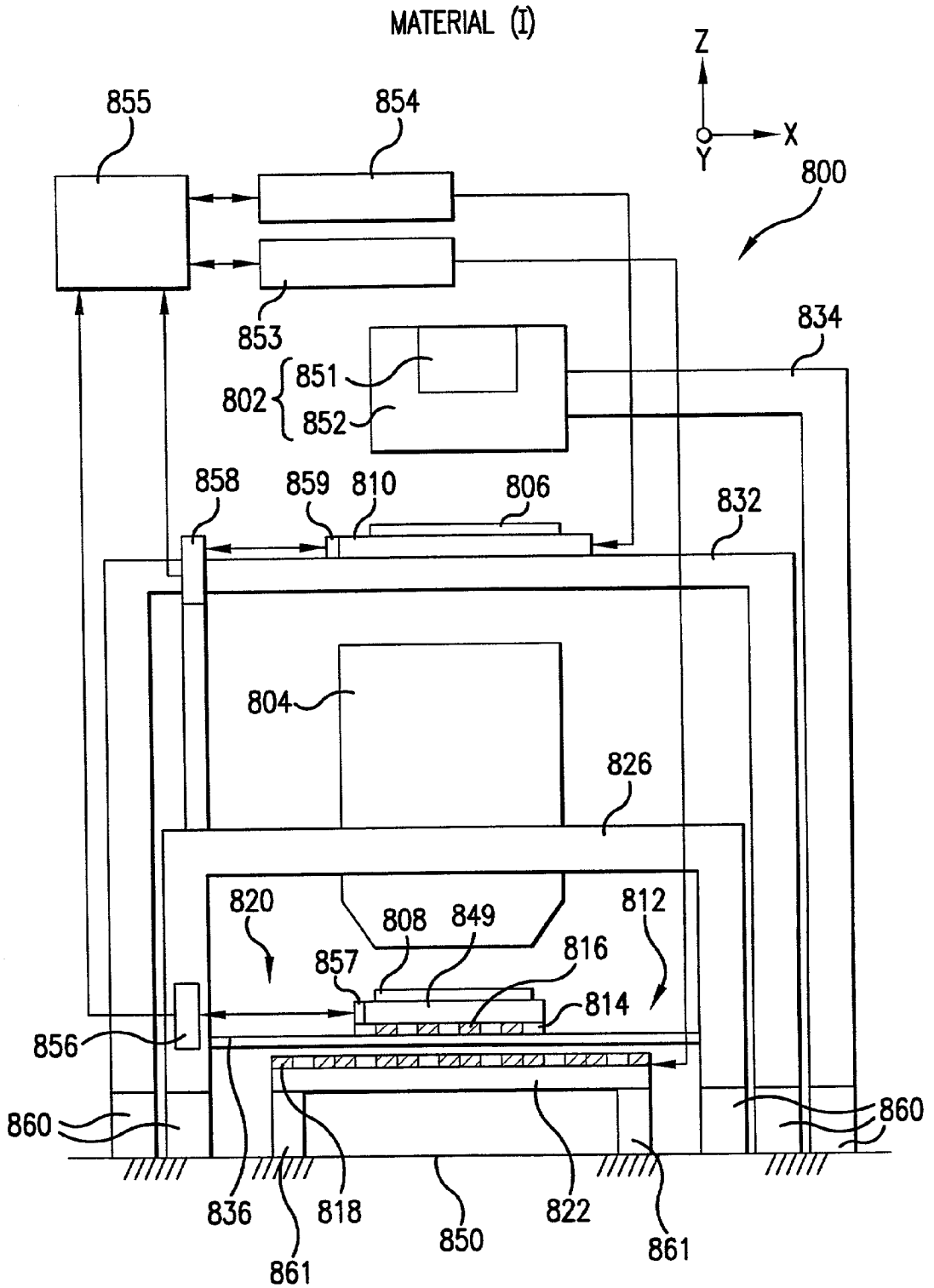

FIG. 11

MATERIAL (II)-7

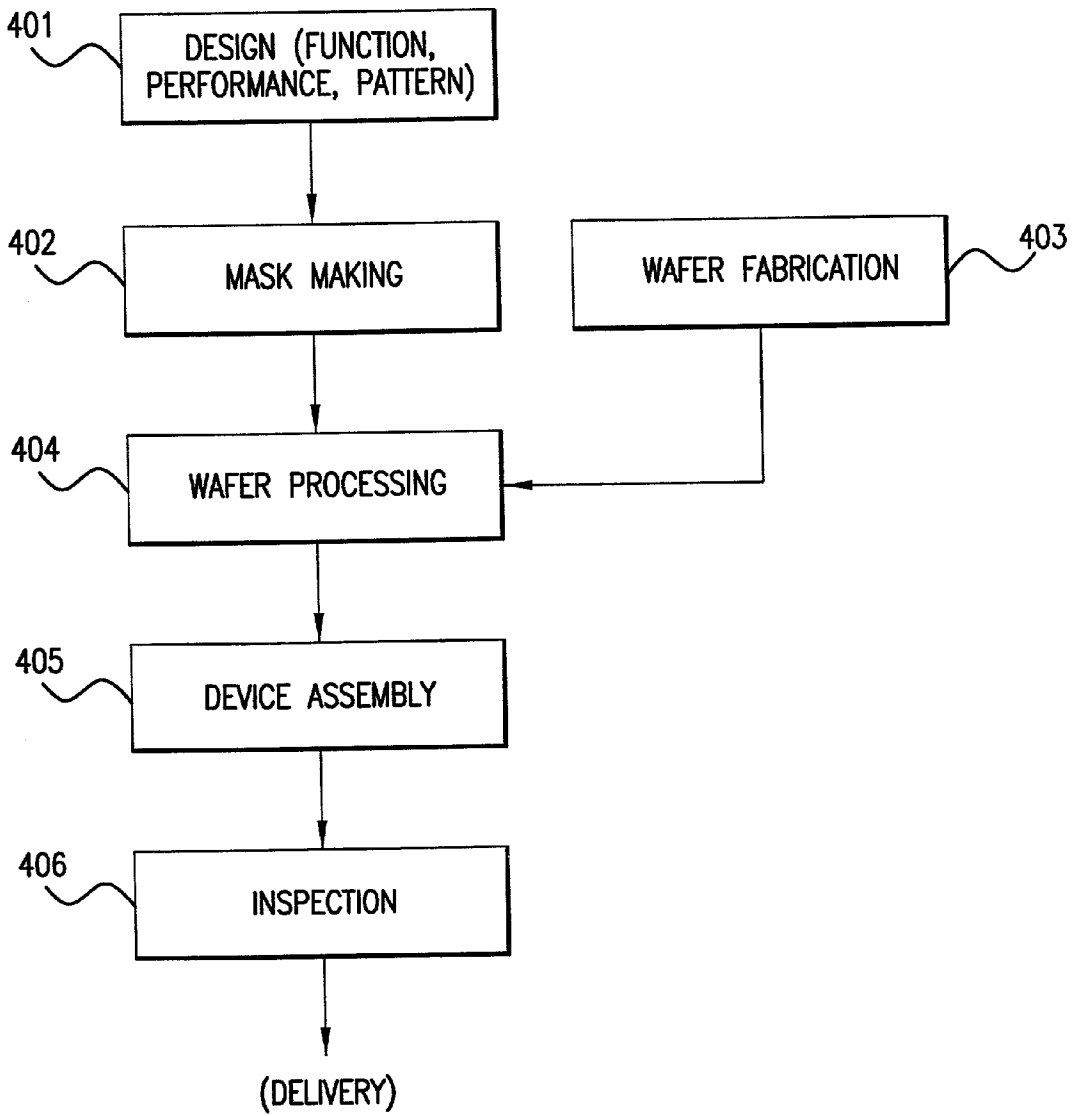

FIG. 12

MATERIAL (II)-8

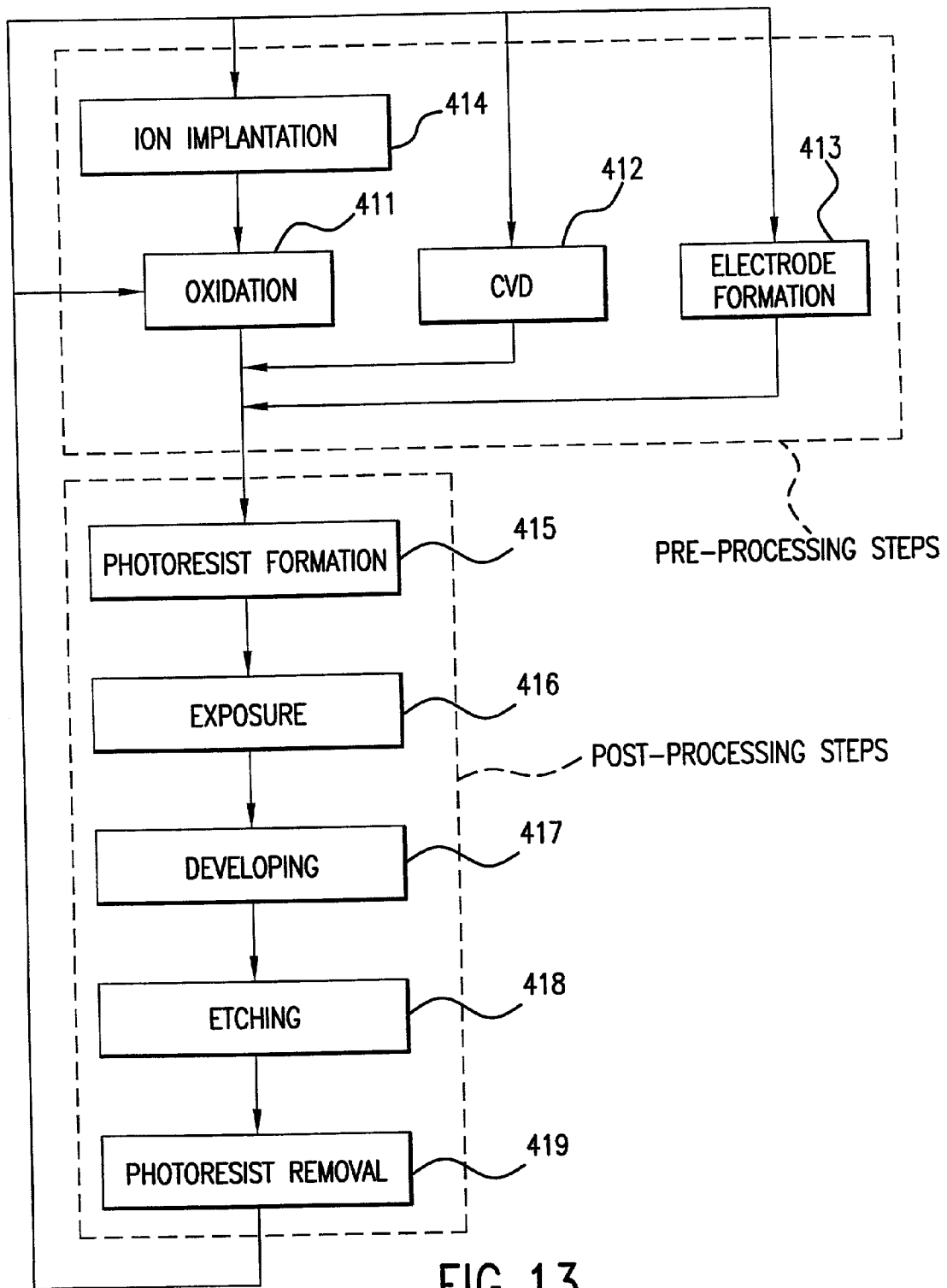

FIG. 13

## SIX DEGREE OF FREEDOM CONTROL OF PLANAR MOTORS

### TECHNICAL FIELD

[0001] This invention relates generally to electric motors and more particularly to six degree of freedom control of electric planar motors.

### BACKGROUND ART

[0002] Electric motors are used in a variety of electrical equipment. For example, wafer stages utilize linear or planar electric motors to position a wafer during photolithography and other semiconductor processing.

[0003] U.S. Pat. No. 5,623,853, entitled "Precision Motion Stage with Single Guide Beam and Follower Stage" to Novak et al. and U.S. Pat. No. 5,528,118, entitled "Guideless Stage With Isolated Reaction Stage" to Lee ("the '118 patent") discuss examples of semiconductor fabrication equipment and are incorporated herein by reference in their entireties.

[0004] U.S. Pat. No. 4,654,571, entitled "Single Plane Orthogonally Moveable Drive System" to Hinds ("the '571 patent") and U.S. Pat. No. 4,535,278, entitled "Two-Dimensional Precise Positioning Device for Use in a Semiconductor Manufacturing Apparatus" to Asakawa ("the '278 patent") discuss two-dimensional planar electric motors. The motors are two-dimensional in that they have two-dimensional arrays of magnets and armatures instead of magnet tracks and one-dimensional armatures. Further, the magnet arrays and two-dimensional armatures may move with respect to each other in more than two dimensions depending upon the design. Conventional two-dimensional linear motors typically have an array of magnets and an armature having one or more coils disposed on one side of the array of magnets.

[0005] The '278 patent describes a three degree of freedom planar motor and a control method for independently producing forces in the X, Y and  $\theta_z$  (rotation about Z) directions. The method described in the '278 patent is better suited for a moving-coil electric planar motor. In a moving magnet array electric planar motor, the '278 patent describes a method of controlling the motor that can only produce force with groups of four coils that are fully within the magnetic field of the magnet array. In other words, only coils which are completely covered by the magnet array are used to generate forces and coils which are only partially covered by the magnet array are not used to generate forces. Thus, to provide three degree of freedom control of the planar motor at every position, the magnet array must be sufficiently large to cover an area of at least 5 by 3 coils such that 4 by 2 coils are always completely within the magnetic field of the magnet array at all times.

[0006] A platform is attached to the two-dimensional electric motor such that it can be moved and positioned in two or more dimensions by the electric motor. For example, a wafer stage in semiconductor processing equipment may be attached to a coil array or magnet array of a two-dimensional motor and the two-dimensional motor would control the positioning of the wafer stage.

[0007] When used to position a platform, conventional two-dimensional electric motors do not smoothly and accu-

rately position the platform. Presently, a coil array in a typical two-dimensional electric motor moves with respect to a stationary magnet array. As exemplified in the '571 patent, cables and hoses are attached to the coil assembly to supply electrical current and coil cooling fluid or air supply to the coils, respectively. However, the hoses and cables impede free motion of the coil assembly.

[0008] It is desirable to provide an accurate and efficient method of independently controlling a planar electric motor such that it can be driven to position the platform in six degrees of freedom. It is also desirable to provide a planar electric motor whose accuracy in positioning is not limited by wiring and/or coil coolant hoses.

### SUMMARY OF THE INVENTION

[0009] The invention comprises a system and method for independently controlling electric planar motors to move and position in six degrees of freedom. The electric planar motor of the invention is preferably a moving magnet array electric motor comprising a magnet array and a coil array. The current supplied through coils of the coil array interacts with the magnetic field of the magnets of the magnet array to generate forces between the magnet and coil arrays. The generated forces provide motion of the magnet array relative to the coil array in a first, second and third directions generally orthogonal to each other, as well as rotation about the first, second and third directions. The invention teaches the levels of current to be applied to the coils to achieve accurate control of the electric planar motor in six degrees of freedom.

[0010] The controlling method of the invention is achieved by the interaction of current in the coil and a magnetic field associated with the magnet. The method for controlling a planar electric motor having a magnet array and a coil array for positioning in six degrees of freedom, includes (1) determining the currents to be applied to the coils to generate forces between the magnet array and the coil array in a first (X), second (Y), and third (Z) directions, (2) determining a resultant torque about the first, second, and third directions between the magnet array and the coil array generated by the forces generated by the determined currents; (3) determining current adjustments to compensate for or cancel out the resultant torque; and (4) applying a sum of the determined currents and determined current adjustments to the coils to interact with the magnetic fields of the magnet array.

[0011] The method for controlling a planar electric motor for positioning in six degrees of freedom may further include determining the position of the magnet array relative to the coil array and using the determined position to determine currents, resultant torque or current adjustments. The currents to be applied to coils in the portion of the coil array may be selected from sinusoidal, triangular and square waveforms. The method may further include determining the forces to be generated between the magnet array and the coil array in the X, Y, and Z directions to result in forces in the X, Y and Z directions or torques about X, Y, and Z directions. The current adjustment is preferably determined for each coil in the portion of the coil array.

[0012] The invention utilizes all of the coils within the magnetic field of the magnet array, including those which are only partially within the magnetic field of the magnet

array. Thus, the currents to be applied to the coils are determined only for coils in the portion of the coil array that is within the magnetic field of the magnetic array, including those coils which are only partially within the magnetic field of the magnet array and the sum of the determined currents and determined current adjustments is applied only to coils in that same portion of the coil array.

[0013] The magnet array of the invention covers an area equivalent to at least three four-coil sets or groups or a total of twelve coils. Preferably, the magnet array of the invention covers an area equivalent to at least four four-coil groups for a total of sixteen coils and is preferably square. Thus, the magnetic field of the magnet array of such size interacts with a maximum of twenty-five coils, wholly or partially. In other words, a magnet array of such size covers portions of twenty-five or fewer coils.

[0014] In another aspect of the invention, a method for positioning a wafer in a lithography system is provided. The method includes: (1) providing a frame, a stage for supporting the wafer and movable to position the wafer relative to the frame in six degree of freedom, a coil array attached to the frame, and a magnet array adjacent a portion of the coil array, the magnet array being attached to the stage and having magnets generally disposed in a plane, the plane defining a first and second direction; (2) determining currents to be applied to coils in the portion of the coil array to generate forces between the magnet array and the coil array in the first, second, and third directions; (3) determining a resultant torque about the first, second, and third directions between the magnet array and the coil array generated by the forces; (4) determining current adjustments to compensate for the resultant torque; and (5) applying a sum of the currents and current adjustments to the coils to interact with magnetic fields of the magnet array.

[0015] In another aspect of the present invention, a planar motor is provided. The planar motor includes (1) a first member; (2) a second member that interacts with the first member to generate driving force, the second member being movable relative to the first member in six degrees of freedom including a first, second, and third directions by the driving force; and (3) a controller connected to at least one of the first member and second member, the controller determining information related to resultant torque about the first, second, and third directions between the first member and the second member.

[0016] The planar electric motor and its control method may also be used in a positioning device. The positioning device has a support member such as a stage, a magnet array, and a coil array. In a moving magnet planar motor, the support member is attached to the moving magnet array and is positionable by the electric motor in six degrees of freedom. Alternatively, the support member is attached to the moving coil array and is positionable by the electric motor in six degrees of freedom.

[0017] The method appropriately commutates coils and results in accurate and precise movement and positioning of the stage. The methods provide an electrical current distribution or commutation to the active coils of the coil array to control movement of the magnet array with respect to a coil array. The coils of the coil array are distributed in the first (X) and second (Y) direction with a coil period and the magnets of the magnet array are distributed in the first (X)

and second (Y) direction with magnet periods of preferably approximately four-thirds the corresponding coil period, though other magnet period to coil period ratios will work.

[0018] The method applies to both moving magnet and moving coil electric motors although the moving magnet array electric motor is preferred. The moving magnet array electric motor provides more accurate positioning than conventional moving coil electric motors. The moving magnet electric motor does not require wire connections or cooling hoses to the moving part of the motor. Conventional two-dimensional electrical motors are moving coil motors having wires and cooling hoses connected to the moving coil array. By eliminating wires and hose connections to the moving component, positioning devices using the moving magnet array are more accurate than conventional moving coil platforms. However, although the invention is described in terms of a moving magnet array electric motor, the electric motor may be modified to be a moving coil array electric motor wherein the coil array moves relative to the magnet array.

[0019] The method of the invention uses the full active area of the coil array to generate force and torque and permits a large magnet pitch. A large magnet pitch allows the use of larger magnets for a given size motor, which generally have greater magnetic flux. Thus, the use of the full active area of the coil array and a large magnet pitch results in improved motor performance.

[0020] The invention's electric motors and positioning devices should be useful in environments requiring precise and wide ranges of positioning. The electric motor and method of the invention is particularly useful in positioning wafers in semiconductor fabrication processes.

#### BRIEF DESCRIPTION OF THE DRAWINGS

[0021] FIG. 1 shows a perspective view of a moving magnet electric motor in accordance with one aspect of the invention;

[0022] FIG. 2 shows a perspective view of a magnet array of the moving magnet electric motor of FIG. 1;

[0023] FIG. 3 shows a perspective view of a coil array of a moving coil electric motor in accordance with another aspect of the invention;

[0024] FIG. 4 shows a plan view of a magnet array for use with the coil array of the moving coil electric motor shown in FIG. 3;

[0025] FIG. 5 is a schematic illustrating a method to achieve force and motion of a portion of a magnet array relative to a portion of a coil array in X and Y directions and rotation about the Z direction in accordance with a method of the invention;

[0026] FIG. 6 is a side cross-sectional view of a section of the electric motor of FIG. 5

[0027] FIG. 7 is a schematic of four coil groups illustrating the phases of the coils;

[0028] FIG. 8 is a schematic of a group of four coil illustrating the coordinate system of each coil group;

[0029] FIG. 9A depicts a schematic top view of a stage moving over four coil groups illustrating position and force vectors of the coils;

[0030] FIG. 9B depicts a schematic top view of the stage covering the coil groups for illustrating a compensation scheme by the partially covered coils;

[0031] FIG. 10 is a flow chart of a process to achieve control and motion of a planar motor in six degrees of freedom in accordance with the invention; and

[0032] FIG. 11 shows a schematic side view of an example of a photolithography system using the electric motor of the invention.

#### DESCRIPTION OF THE INVENTION

[0033] The invention comprises a system and method for independently controlling electric planar motors to move and position in six degrees of freedom. The following description is presented to enable any person skilled in the art to make and use the invention. Descriptions of specific applications are provided only as examples. Various modifications to the preferred embodiment will be readily apparent to those skilled in the art, and the general principles defined herein may be applied to other embodiments and applications without departing from the spirit and scope of the invention. Thus, the invention is not intended to be limited to the embodiments shown, but is to be accorded the widest scope consistent with the principles and features disclosed herein.

[0034] FIG. 1 illustrates a moving magnet electric motor (planar motor) 20 in accordance with one aspect of the invention. The electric motor 20 has a coil array 22 and a magnet array 24. Electric current is supplied to the coils 26 of the coil array 22. The current interacts with the magnetic flux of the magnets of the magnet array 24 to generate forces between the coil array 22 and the magnet array 24. The forces move and position the magnet array 24 relative to the coil array 22. The invention teaches the levels of current to be applied to the coils 26 to achieve six degree of freedom control of the electric motor (planar motor) 20.

[0035] As shown in FIG. 1, a surface of the coil array 22 is in proximity to an opposing surface of the magnet array 24 during operation of the electric planar motor 20. Preferably, the opposing faces of the coil and magnet arrays 22, 24 are separated by several mm or less during operation. One or more air bearings (not shown) may be provided to separate the coil array 22 from the magnet array 24. Other types of bearings, such as magnetic bearings, may be utilized. Construction and usage of an air bearing are known to those skilled in the art. For example, the '571 patent teaches an air bearing adaptable for use in the invention. The air bearing may position the coil array 22 and the magnet array 24 at a neutral position about which the coil array 22 and the magnet array 24 can move relative to each other in six degrees of freedom.

[0036] When one or more air bearings separate the coil array 22 and the magnet array 24 relative to each other, the coil array 22 and/or the magnet array 24 may be potted with any suitable material such as epoxy or may be covered with a flat plate made of, for example, ceramic, composite, or metal, to form generally flat surfaces. The generally flat surfaces improve performance of the air bearing in separating or levitating the coil array 22 and magnet array 24 relative to each other.

[0037] Coils 26 of the coil array 22 are periodically distributed in X (first) direction and Y (second) directions.

The coil array 22 has a first coil period; 28 in the X direction defined as the distance from the center of one coil to the center of an adjacent coil along the X direction. The coil array 22 further has a second coil period 30 in the Y direction defined as the distance from the center of one coil to the center of an adjacent coil along the Y direction. The coil period 28 in the X direction is preferably approximately equal to the coil period 30 in the Y direction.

[0038] As shown in FIG. 1, each coil 26 in the coil array 22 has approximately the same shape and size. Although the coils 26 having approximately the same shape and size are preferred, the coils of the coil array 22 may have varying shapes and/or sizes. Each coil 26 preferably covers as much of an area of one coil period in both the X and Y directions as possible in order to maximize the force generated from the interaction between the magnet array 24 and the coil array 26 and thus minimizes the coil power input necessary to achieve a desired amount of force. A rectangular profile of the coil 26 maximizes the area occupied by each coil 26 within the area defined by the coil periods 28, 30 and thus is preferred. As is evident, when the periods 28 and 30 are approximately equal, the profile of the coil 26 approximates a square.

[0039] Each coil 26 may be disposed about a magnetically impermeable post 32. The magnetically impermeable post 32 facilitates mounting and aligning coil 26 without distorting the magnetic field. In contrast, a magnetically permeable post would focus a magnetic field created by the coil 26 and produce an uneven field distribution over the outline of the coil 26.

[0040] A backing panel 34 may be attached to one surface or side of the coil array 22. The backing panel 34 may comprise a magnetically permeable material such as iron or may comprise a magnetically impermeable material such as plastic or ceramic. A magnetically permeable backing panel 34 increases the permanent magnetic flux through the coils and thus increases the performance of the electric planar motor 20.

[0041] As shown in FIG. 1, the coil array 22 has a first coil array dimension 36 in the X direction and a second coil array dimension 38 in the Y direction. Also, the magnet array has a first magnet array dimension 40 in the X direction and a second magnet array dimension 42 in the Y direction. As is evident, the first coil array dimension 36 is larger than the first magnet array dimension 40 and second coil array dimension 38 is larger than the second magnet array dimension 42.

[0042] FIG. 2 is a perspective view of the magnet array 24, illustrating the surface or side of the magnet array 24 which faces the coil array 22 during operation of the electric motor (planar motor) 20.

[0043] Similar to the coils of the coil array 22, magnets in the magnet array 24 are also periodically distributed in two directions. The magnet array has a first magnet period 44 in the X direction defined as the distance from the center of one magnet to the center of the next magnet having the same polarity along the X direction. The magnet array 24 further has a second magnet period 46, in the Y direction, which is the distance from the center of one magnet to the center of the next magnet having the same polarity along the Y direction.



[0044] The magnet periods **44**, **46** of the magnet array **24** in the X and Y directions are related to the periods **28**, **30** of the coil array **22** in the X and Y directions, respectively. Specifically, the first magnet period **44** in the X direction is a approximately four-thirds of the first coil period **28** in the X direction. Further, the second magnet period **46** in the Y direction is approximately four-thirds of a second coil period **30** in the Y direction. Thus, when the coil periods **28**, **30** in the X and Y directions are approximately equal, the magnet periods **44**, **46** in the X and Y directions are also approximately equal.

[0045] The magnets are preferably attached to a magnetically permeable backing **48**. The magnetically permeable backing **48** completes flux paths between adjacent magnets of opposite polarities to increase the magnetic flux of each polarity, as will be described in more detail below.

[0046] Preferably, the magnets in the magnet array **24** alternate in polarity in both the X and the Y directions such that the magnets along any diagonals of the X and the Y directions are of the same polarity. The interior magnets **50** in the magnet array **24** preferably have the same magnetic flux. In contrast, non-corner edge magnets **52** and corner magnets **54**, **56**, **58**, **60** of the magnet array **24** have a fraction of the magnetic flux of the interior magnets **50**. For example, the non-corner edge magnets **52** of the magnet array **24** have approximately one-half the magnetic flux of the interior magnet **50**. The corner magnets **54**, **56**, **58**, **60** have one-quarter the flux of the interior magnets **50**. The edge and corner magnets may have any other suitable fractional magnetic fluxes relative to the magnetic fluxes of the interior magnets **50**. The fractional fluxes for the non-corner edge magnets **52** and for the corner magnets **54**, **56**, **58**, **60** complete flux paths with each other and with the interior magnets **50** while simultaneously minimizing fringe magnetic fields at the edges of the magnet array **24**. Without the fractional magnetic fluxes of the edge and corner magnets, the fringe magnetic fields at the magnet array edges may otherwise degrade performance of the moving magnet electric motor.

[0047] Other types and arrangements of the magnets may also be used in the control method of the invention. For example, wedge magnets may be utilized to facilitate the completion of the magnetic fields. Magnet arrays using wedge magnets are disclosed in, for example, U.S. Pat. No. 6,188,147, entitled "Wedge and Transverse Magnet Arrays", issued on Feb. 13, 2001, by Hazelton et al. and copending application Ser. No. 09/309,721, entitled "Planar Electric Motor and Positioning Device Having Transverse Magnets", filed on May 11, 1999, both of which are incorporated herein by reference.

[0048] The moving magnet planar motor **20** is generally preferable to a moving coil electric motor because the moving magnet array **24** does not require electrical current connections or hoses to carry cooling fluids. Wires and hoses connected to a coil array of the moving coil electric motor may interfere with the motion of the coil array with respect to the magnet array in a moving coil planar motor. Nonetheless, the method of controlling an electric planar motor in six degrees of freedom of the invention as described below may also be applied to a moving coil planar motor, such as shown in FIGS. 3 and 4.

[0049] FIGS. 3 and 4 show, respectively, a coil array **122** and a magnet array **124** of a moving coil planar motor **120**

according to another aspect of the invention. The coil array **122** is movable relative to the magnet array **124** by supplying electric current to one or more of the coils **126** of the coil array **122**. The current interacts with the magnetic flux of the magnets of the magnet array **124** to generate forces between the coil array **122** and the magnet array **124**. The forces move and position the coil array **122** relative to the magnet array **124**.

[0050] A face or side **162** of the coil array **122** is in close proximity to the face or side of the magnet array **124** shown in FIG. 4 during operation of the electric planar motor **120**. Preferably, the opposing faces of the coil and magnet arrays **122**, **124** are separated by a few mm or less during operation. One or more air bearings **164**, as described above with reference to the moving magnet motor **20**, may be provided to separate the coil array **122** from the magnet array **124**. In addition, when one or more air bearings **164** separate the coil array **122** and the magnet array **124** relative to each other, the coil array **122** and/or the magnet array **124** may be potted or covered with a flat plate, as described above, to form generally flat surfaces. The generally flat surfaces improve performance of the air bearing in separating or levitating the coil array **122** and magnet array **124** relative to each other.

[0051] Coils **126** of the coil array **122** are periodically distributed in X (first) direction and Y (second) directions. The coil array **122** has a first coil period **128** in the X direction defined as the distance from the center of one coil to the center of an adjacent coil along the X direction. The coil array **122** further has a second coil period **130** in the Y direction defined as the distance from the center of one coil to the center of an adjacent coil along the Y direction. The coil period **128** in the X direction is preferably approximately equal to the coil period **130** in the Y direction.

[0052] Similar to the coils **26** of the coil array **22** of the moving magnet planar motor **20**, each coil **126** may be disposed about a magnetically impermeable post **132**. Further, a backing panel **134** may be attached to one surface or side of the coil array **122**.

[0053] The magnets are preferably attached to a magnetically permeable backing **148**. The magnetically permeable backing **148** completes flux paths between adjacent magnets of opposite polarities to increase the magnetic flux of each polarity, as will be described in more detail below.

[0054] As shown in FIG. 4, the magnets in the magnet array **124** are also periodically distributed in the X and Y directions. The magnet array has a first magnet period **144** in the X direction defined as the distance from the center of one magnet to the center of the next magnet having the same polarity along the X direction. The magnet array **124** further has a second magnet period **146** in the Y direction defined as the distance from the center of one magnet to the center of the next magnet having the same polarity along the Y direction.

[0055] Preferably, the magnets in the magnet array **124** alternate in polarity in both the X and the Y directions such that the magnets along any diagonals of the X and the Y directions are of the same polarity. The first magnet period **144** in the X direction is preferably approximately four-thirds of the first coil period **128** in the X direction. Further, the second magnet period **146** in the Y direction is approximately four-thirds of a second coil period **130** in the Y

direction. Thus, when the coil periods **128**, **130** in the X and Y directions are approximately equal, the magnet periods **144**, **146** in the X and Y directions are also approximately equal.

[0056] In the moving coil planar motor **120**, the total number of coils in the coil array **122** is preferably a multiple of 4. As will be described below with reference to **FIG. 5**, the principles of operation for control and movement in six degrees of freedom in the X, Y, and Z directions and rotation about the X, Y, and Z directions use four sets of four adjacent, approximately identically shaped coils.

[0057] The above-described planar motors **20**, **120** are similar to those described in U.S. Pat. No. 6,208,045 entitled "Electric Motors and Positioning Devices Having Moving Magnet Arrays and Six Degrees of Freedom", issued on Mar. 27, 2001 by Hazelton et al., the entirety of which is incorporated herein by reference.

[0058] Control in Six Degrees of Freedom

[0059] The interactions of currents in the coils and magnetic flux of the magnets in the magnet array to generate forces between the magnet array and the coil array will now be described. Although the following description is in terms of a moving magnet electric motor **20**, as is preferred, similar concepts and principles may be used in a moving coil electric motor **120**.

[0060] A general qualitative description of the control of the moving magnet motor in three degrees of freedom will be described with reference to **FIG. 5**. **FIG. 5** is a schematic representation of a section of the moving magnet electric motor **20**. The three degrees of freedom are in the X and Y directions and rotation about the Z direction. A general qualitative description of the control of the moving magnet motor in six degrees of freedom will be described with reference to **FIG. 6**. **FIG. 6** is a side cross-sectional view of a portion of the electric motor section of **FIG. 5**. The six degrees of freedom are in the X, Y, and Z direction and rotation about the X, Y, and Z directions.

[0061] **FIG. 5** shows a sub-array of the magnet array **24** and a set of four coils **200**, **202**, **204**, **206** which are part of the coil array **22**. In the embodiment shown in **FIG. 5**, each coil has first and second coil periods **28**, **30** in the X and Y directions, respectively, approximately equaling three-fourths of first and second magnet periods **44**, **46**, respectively.

[0062] By appropriately commutating currents flowing in the coils **200**, **202**, **204**, **206**, force is generated between the coil array **22** and the magnet array **24**. For example, in the relative positions of the coil and magnet arrays **22**, **24** shown in **FIG. 5**, a counter-clockwise current **208** supplied through coil **200** interacts with the magnetic field of the magnets covered by the coil **200** to exert a force on the coil array **22**, in a positive X direction as indicated by arrow **210**, according to the right-hand rule and the Lorentz force laws.

[0063] In a two-phase commutation scheme to generate a force between the coil and magnet arrays **22**, **24** in the positive X direction **210**, two coils **200**, **202** are commutated. For example, in the relative positions of the coil and magnet arrays **22**, **24** shown in **FIG. 5**, the counter-clockwise current **208** supplied through the coil **200** is at a maximum while no current is supplied through the coil **202**.

As the coil **200** moves in the positive X direction **210** and its center **200c** approaches the next magnetic pole **212**, the counter-clockwise current **208** supplied through the coil **200** approaches zero. As the coil **200** moves in the positive X direction **210**, the coil **202** also moves in the direction **210**, and its center **202c** moves toward location **214**.

[0064] To maintain the force in the positive X direction **210**, a counter-clockwise current is supplied through the coil **202**. The counter-clockwise current in the coil **202** increases sinusoidally to its maximum. When the center **202c** of coil **202** coincides with the location **214**, the current in the coil **202** will be at its maximum.

[0065] Similarly, current can be commutated to flow in clockwise direction **216** through the coil **204** to generate a force on the coil array **22** in a negative Y direction **218**. As in the movement in the positive X direction **210**, the coils **202**, **204** may be commutated in a similar fashion as the coils **200**, **202** to provide a continuous force in the negative Y direction **218**. As with the coils **200**, **202**, the commutation of the coils **202**, **204** is a two phase commutation.

[0066] With respect to coil **206**, magnets **220**, **222**, **224**, **226** are symmetrically positioned about its center **206c**. When the coil **206** is symmetric about its center **206c** and the coil center **206c** is centrally disposed over the magnets **220**, **222**, **224**, **226**, the forces generated by the interaction between the current through the coil **206** and the magnetic fields of the magnets **220**, **222**, **224**, **226** are cancelled. Thus, unlike the other three coils **200**, **202**, **204**, the coil **206** cannot generate a force between the coil and magnet arrays **22**, **24** in the position as shown in **FIG. 5**.

[0067] Only a few examples of commutation have been described. Clearly, as will be appreciated by those skilled in the art, many other commutations may be applied to the coils **200**, **202**, **204**, **206** and the other coils in the coil array **22** to achieve forces and motions in X and Y directions. By providing at least two sets of four coils and by simultaneously generating forces in both the X and Y directions, such as in the positive X and negative Y directions **210** and **218** respectively, the electric motor **20** can also be controlled to rotate the moving magnet array **24** relative to the stationary coil array **22** about the Z direction.

[0068] Referring now to **FIG. 6** the commutation of the coils to generate a force in the Z direction will now be described, enabling six degree of freedom control of the planar motor. By selectively generating forces in the Z direction, torques about the X and Y directions can be achieved.

[0069] **FIG. 6** is a side cross-sectional view of a portion of the electric motor section of **FIG. 5** showing the coils **200** and **202** of either a moving coil or moving magnet electric motor. The coil **202** comprises coil portions **202a** and **202b** about its center **202c**. Similarly, coil **200** comprises coil portions **200a** and **200b** about its center **200c**. The coil **202** experiences nonvertical components of magnetic flux density B when the magnet is at off-center locations relative to a coil portion, such as coil portions **202a**, **202b**. A current is applied to the coil **202** which flows through coil portion **202a** in a direction into the plane of **FIG. 6** and through coil portion **202b** in a direction out of the plane of **FIG. 6**. Nonvertical components of the magnetic flux density B interact with the current flowing through the coil portions **202a** and **202b** to produce forces  $F_{202a}$  and  $F_{202b}$ , respectively, in the Z direction.

[0070] In a two-phase commutation scheme to exert force on the coil array in the Z direction relative to the magnet array, the coils **200** and **202** are commutated. For example, in the position shown in FIG. 6, the current through the coil **202** is at a maximum while the coil **200** has no current flowing through it. When the coil **202** is moved in the X direction and its coil portion **202a** approaches magnetic pole **228**, the current through the coil **202** will approach zero. As the coil **202** moves in the X direction, the coil **200** also moves in the X direction and its center portion **200c** moves toward a position directly below magnetic pole **212**.

[0071] To maintain the force in the Z direction, the current in the coil **200** is commutated which flows through coil portion **200a** in a direction out of the plane of FIG. 6 and through coil portion **200b** in a direction into the plane of FIG. 6. The current applied to coil **200** will be approximately  $90^\circ$  out of phase relative to the current applied to coil **202**. The current in the coil **200** increases sinusoidally to its maximum. When the center **200c** of coil **200** is directly below magnet pole **212**, the current in the coil **200** will be at its maximum.

[0072] Only a few examples of commutation have been described. Clearly, as will be appreciated by those skilled in the art, many other commutations may be applied to the coils **200**, **202**, **204**, **206** and the other coils in the coil array **22** to achieve force and motion of the coil array **22** with respect to the magnet array **24** in six directions: in the X, Y, Z directions and rotation about the X, Y, Z directions.

[0073] A more detailed quantitative description of the control of the moving magnet motor in six degrees of freedom with torque control will now be described with reference to FIGS. 7-9.

[0074] The current commutation scheme is applied to the coils within the magnetic field of the magnets of the magnet array **22**. These are referred to as the active coils and include coils which are only partially within the magnetic field of the magnets of the magnet array **22**. The current supplied through the active coils interact with the magnetic field of the magnet array **24** to generate a force between the magnet and coil arrays **22**, **24**. No current is applied to the inactive coils, coils that are not within the magnetic field of the magnets of the magnet array **22**. Thus, all coils that are wholly or partially within the magnetic field of the magnet array **24** are utilized to generate forces to control the stage in six degrees of freedom.

[0075] The utilization of coils only partially within the magnetic field of the magnet array **24** maximizes the forces generated. Further, it allows the utilization of a smaller magnet array **24**. Specifically, the magnet array **24** needs to only cover the size of three sets or groups of four coils or a total of twelve coils in order to control the magnet array **24** in six degrees of freedom.

[0076] The following derivation of the coil current commutation scheme to control the moving magnet motor **20** in six degrees of freedom is described in terms of a magnet array covering a square of four by four coils. When all four edges of the magnet array or stage are aligned with the edges of the four by four set of coils, the stage completely covers or overlaps with 16 coils. When two of the four edges of the stage are aligned with the edges of the four by four set of coils, the stage completely covers 12 coils and partially

covers 8 coils. When none of the four edges of the stage are aligned with the edges of the four by four set of coils, the stage completely covers 9 coils and partially covers 16 coils, for a total of 25 coils. As is evident, in each case, the stage covers an equivalent of 16 full coils.

[0077] To achieve six degree of freedom control of the moving magnet motor, the coils need to generate forces in the X, Y, Z directions. As is evident, forces in the X, Y, and Z directions provides linear control and movement in the X, Y, and Z directions. These forces can also generate torques about the X, Y, and Z axes, since there are multiple coils at different X, Y positions. For example, two coils separated in the X direction can produce different amounts of Z force to create a torque about the Y axis.,

[0078] As shown in FIG. 7, the planar motor has four phases A, B, C, and D and is essentially a four-phase device. The phase of each coil is defined by the relative positions and polarities of the magnets covered by the coil. The negative sign associated with a given phase indicates that the coil covers similarly positioned magnets with polarities opposite those of the same phase without a negative sign. For example, a B phase coil covers the same number and position of magnets as a -B phase coil but with opposite polarities.

[0079] To enable six degree of freedom control of the planar motor, moving magnet array or stage must cover an area of twelve coils. Preferably, the area is of sixteen coils, and square of four by four coils. However, other shapes of the magnet array may be utilized, such as a L-shaped, cross-shaped or T-shaped.

[0080] Torque Control

[0081] In the following derivation of a commutation scheme, the notations of the various parameters are first defined. The torque generated between a single four-coil group and the magnet array is then determined. Finally, the torque generated between the four coil groups and the magnet array or stage is determined. The torque-compensated commutation scheme allows accurate and precise control and positioning of the stage in six degrees of freedom.

[0082] Notation

[0083] In the following derivation of the coil current commutation scheme to control the moving magnet motor **20** in six degrees of freedom, various parameters, vectors, and matrices are defined in Tables I, II, and III, respectively. Subscripts A, B, C, and D denote the four coil phases in a coil group. Subscripts **1**, **2**, **3**, and **4** denote each of the four coil groups under the stage.

TABLE I

Scalar Parameter	Definition
$x, y, z$	position of the center of gravity of the stage relative to peak-force position
$I_x, I_y, I_z$	components for the vector $r$
$P_{xi}, P_{yi}, P_{zi}$	components of the vector $p_i$
$R_x, R_y, R_z$	desired forces for the entire stage in the X, Y and Z directions, respectively
$\Delta_x, \Delta_y, \Delta_z$	magnitude of correction or adjustment factors for X, Y, and Z torque

[0084]

TABLE II

Vector	No. of Elements	Definition
I	4	currents in each coil of a coil group
r	3	desired force vector for a coil group in the X, Y, and Z directions
f	3	force vector produced by a coil group
t	3	torque vector produced by a coil group, measured at the origin of the coil group
y	6	output force and torque vector produced by a coil group
q <sub>i</sub>	3	position vector from the center of gravity of the stage to the origin of coil group i in the X, Y, and Z directions
F	3	force vector produced by the entire stage
T	3	torque vector produced by the entire stage (measured at the center of gravity of the stage)
Y	6	force and torque output vector produced by the entire stage

[0085]

TABLE III

Matrix	Size	Definition
C	4 × 3	commutation matrix; same for all coil groups
K <sub>f</sub>	3 × 4	force constant matrix; same for all coil groups
K <sub>t</sub>	3 × 4	torque constant matrix; same for all coil groups
K	6 × 3	input-output matrix for a coil group; same for all coil groups
p	3 × 4	position vectors (each column) for each coil in a group, relative to the origin of the group; same and constant for all coil groups
A	6 × 6	input-output matrix for the complete stage

[0086] Force Resulting from Open Loop Commutation for the Coil Group

[0087] As shown in FIG. 8, an origin for the four-coil group can be arbitrarily defined as the center of the A-phase (lower-left) coil. A different origin may be selected, preferably at the center of one of the other coils in the coil group. A current vector I for the currents in the four coils may be obtained by multiplying a commutation matrix C, which depends only on the X-Y position of the stage, by the desired force vector r:

$$I = Cr = \begin{bmatrix} \sin(x)\cos(y) & \cos(x)\sin(y) & \cos(s)\cos(y) \\ \cos(x)\cos(y) & -\sin(x)\sin(y) & -\sin(x)\cos(y) \\ -\sin(x)\sin(y) & \cos(x)\cos(y) & -\cos(x)\sin(y) \\ -\cos(x)\sin(y) & -\sin(x)\cos(y) & \sin(x)\sin(y) \end{bmatrix} \begin{bmatrix} r_x \\ r_y \\ r_z \end{bmatrix}$$

[0088] The above equation assumes a commutation sinusoidal waveform although other waveforms such as square and/or triangular waveforms, may be utilized.

[0089] The force constant for a group of coils is given by:

$$K_f = \begin{bmatrix} \sin(x)\cos(y) & \cos(x)\cos(y) & -\sin(x)\sin(y) & -\cos(x)\sin(y) \\ \cos(x)\sin(y) & -\sin(x)\sin(y) & \cos(x)\cos(y) & -\sin(x)\cos(y) \\ \cos(x)\cos(y) & -\sin(x)\cos(y) & -\cos(x)\sin(y) & \sin(x)\sin(y) \end{bmatrix}$$

[0090] Matrix K<sub>f</sub> is simply the transpose of matrix C, or C<sup>T</sup>. The four columns of matrix K<sub>f</sub> are force-constant vectors for the four coils in the group and the three rows are components corresponding to coordinates X, Y and Z.

[0091] The force f produced by the coil group can be found by multiplying the force-constant matrix K<sub>f</sub> by the current vector I:

$$f = K_f I$$

[0092] After simplification, the equation for force f is simplified to:

$$f = \begin{bmatrix} r_x \\ r_y \\ r_z \end{bmatrix} = r$$

[0093] The above result shows that with the commutation law used, a group of four coils can produce any desired force vector. If the commutation waveform were perfectly sinusoidal and the magnets were perfectly symmetrical, there would be no force ripple as the stage moves.

[0094] Torque Resulting from Open Loop Commutation for the Coil Group

[0095] Torque t is defined to be about the origin of the coil group. The basic equations for torque t are given by:

$$t = p \times f$$

$$t = p \times (K_f I)$$

[0096] Factoring out the current I results in similar equations for the torque constant K<sub>t</sub>:

$$K_t = t I^{-1}$$

$$K_t = p \times K_f$$

[0097] A position vector is defined as the vector extending from the origin of the coil group to the center of each coil. Position matrix p is given by:

$$p = \begin{bmatrix} 0 & \frac{3\pi}{2} & 0 & \frac{3\pi}{2} \\ 0 & 0 & \frac{3\pi}{2} & \frac{3\pi}{2} \\ 0 & 0 & 0 & 0 \end{bmatrix}$$

[0098] The four columns of the p matrix are the position vectors for the four coils of the coil group.

[0099] Matrix  $K_i$  may be determined by taking the cross-products of each column of  $p$  with the respective column of  $K_r$ . This cross-product is:

$$K_i = \frac{3\pi}{2} \begin{bmatrix} 0 & 0 & -\cos(x)\sin(y) & \sin(x)\sin(y) \\ 0 & \sin(x)\cos(y) & 0 & -\sin(x)\sin(y) \\ 0 & -\sin(x)\sin(y) & \sin(x)\sin(y) & \cos(x)\sin(y) - \sin(x)\cos(y) \end{bmatrix}$$

[0100] The torque  $t$  produced by the group of coils can be expressed by the following equations:

$$t = K_i I = K_i C r$$

$$t = \frac{3\pi}{2} \begin{bmatrix} 0 & -\sin(y)\cos(y) & \sin^2(y) \\ \sin(x)\cos(x) & 0 & -\sin^2(x) \\ -\sin^2(y) & \sin^2(x) & 0 \end{bmatrix} \begin{bmatrix} r_x \\ r_y \\ r_z \end{bmatrix}$$

[0101] Given that the coil group as a whole has three inputs (the three components of the desired force vector) and six outputs (the three components of each of the force and torque vectors), the equations for  $f$  and  $t$  can be rewritten as:

$$\begin{bmatrix} f_x \\ f_y \\ f_z \\ t_x \\ t_y \\ t_z \end{bmatrix} = \begin{bmatrix} 1 & 0 & 0 \\ 0 & 1 & 0 \\ 0 & 0 & 1 \\ 0 & -\frac{3\pi}{2}\sin(y)\cos(y) & \frac{3\pi}{2}\sin^2(y) \\ \frac{3\pi}{2}\sin(x)\cos(x) & 0 & -\frac{3\pi}{2}\sin^2(x) \\ -\frac{3\pi}{2}\sin^2(y) & \frac{3\pi}{2}\sin^2(x) & 0 \end{bmatrix} \begin{bmatrix} r_x \\ r_y \\ r_z \end{bmatrix} \quad (1)$$

[0102] Denoting the six-element vector containing forces and torques as  $y$  and the six by three matrix  $K$ , the above equation can be rewritten as:

$$y = K r$$

[0103] The Complete Stage: Four Four-Coil Groups

[0104] FIG. 9A is a schematic of a stage or magnet array 24 moving over four four-coil groups of the coil array 22 illustrating position and force vectors of the coils. The position vectors  $q$  point from the center of gravity of the stage to the origin of each of the four coil groups.

[0105] As noted above, the stage may cover up to 25 coils, some partially and some completely. The effects of the partially covered coils is simplified in the following analysis. For example, in the lower left coil group 300 shown in FIG. 9B, three of the coils are partially covered and one of the coils is completely covered. The three partially covered coils generate only a fraction of the force they would otherwise generate.

[0106] The difference in the force generated is compensated by two partially covered coils 302 above the upper left coil group, two partially covered coils 304 to the right of the lower right coil group, and one partially covered coil 306 in the far upper right corner. Including this effect in the analysis

would change the  $K$  matrices because the moment arms for the partial coils would be different. However, matrix  $K$  can still be obtained for each coil group as a function of stage position.

[0107] The complete stage covers or interacts with an equivalent of four coil groups. Each coil group has an independent set of three inputs (the components of the vector  $r$ , the desired force vector) and six outputs (the components of  $y$ , the output force and torque vector). As noted above, subscripts 1, 2, 3, and 4 reference each of the four coil groups under the stage.

[0108] Vector  $q_i$  is defined as the position vector extending from the center of gravity of the stage to the origin of the coil group  $i$ . Using this notation, the total force and torque  $Y$  on the stage can be expressed as:

$$Y = \begin{bmatrix} 1 & 0 & 0 & 0 & 0 & 0 \\ 0 & 1 & 0 & 0 & 0 & 0 \\ 0 & 0 & 1 & 0 & 0 & 0 \\ 0 & -q_{z1} & q_{y1} & 1 & 0 & 0 \\ q_{z1} & 0 & -q_{x1} & 0 & 1 & 0 \\ -q_{y1} & q_{x1} & 0 & 0 & 0 & 1 \end{bmatrix}$$

$$y_1 + \begin{bmatrix} 1 & 0 & 0 & 0 & 0 & 0 \\ 0 & 1 & 0 & 0 & 0 & 0 \\ 0 & 0 & 1 & 0 & 0 & 0 \\ 0 & -q_{z2} & q_{y2} & 1 & 0 & 0 \\ q_{z2} & 0 & -q_{x2} & 0 & 1 & 0 \\ -q_{y2} & q_{x2} & 0 & 0 & 0 & 1 \end{bmatrix} y_2 + \dots$$

[0109] Defining each of the six by six matrices  $Q_i$ , the above equation can be rewritten as:

$$Y = \sum_4 Q_i y_i$$

$$Y = \sum_4 Q_i K_i r_i$$

[0110] Table IV lists the components of the position vector  $q$  and the force vector  $r$  for each coil group.

$$Y = \sum_4 Q_i y_i$$

$$Y = \sum_4 Q_i K_i r_i$$

[0111] The adjustment factors ( $\Delta$ 's) are introduced to compensate for the unwanted torque. The following analysis is intended to explain the relationship among the forces, intended torques and the adjustment factors, which comprises a significant part of the invention.

[0112] Torque Generated by the Electric Motor on the Stage

[0113] The total torque generate by all four coil groups can be determined by summing the individual coil group torques

and the cross product of the position and force vectors for each coil group. This process is detailed below for each component coordinate X, Y, and Z.

[0114] Torque About the X-axis

[0115] The total torque about the X-axis is:

$$T_x = \Sigma t_x + \Sigma (q_y f_z - q_z f_y) \quad (2)$$

[0116] The first term  $\Sigma t_x$  is the X-axis torque about the origin of each coil group. Using the values for the force vector  $r$  from Table IV in equation (1) above, the torque for each of the four coil groups are expressed as:

$$t_{x1} = \frac{3\pi}{2} [-\sin(y)\cos(y)(R_y + \Delta_z) + \sin^2(y)(R_z + \Delta_x - \Delta_y)]$$

$$t_{x2} = \frac{3\pi}{2} [-\sin(y)\cos(y)(R_y - \Delta_z) + \sin^2(y)(R_z + \Delta_x + \Delta_y)]$$

$$t_{x3} = \frac{3\pi}{2} [-\sin(y)\cos(y)(R_y + \Delta_z) + \sin^2(y)(R_z - \Delta_x - \Delta_y)]$$

$$t_{x4} = \frac{3\pi}{2} [-\sin(y)\cos(y)(R_y - \Delta_z) + \sin^2(y)(R_z - \Delta_x + \Delta_y)]$$

[0117] Summing these four equations results in the first term  $\Sigma t_x$  of the total torque equation:

$$\sum t_x = 4 \frac{3\pi}{2} (-\sin(y)\cos(y)R_y + \sin^2(y)R_z)$$

[0118] Substituting the position vector  $q$  and force vector  $r$  components from Table IV into equation (2) results in the following total X-axis torque equation:

$$\begin{aligned} T_x = & \sum t_x + \left(\frac{-5\pi}{2} - y\right)(R_z + \Delta_x - \Delta_y) + z(R_y + \Delta_z) + \\ & \left(\frac{-5\pi}{2} - y\right)(R_z + \Delta_x + \Delta_y) + z(R_y - \Delta_z) + \\ & \left(\frac{\pi}{2} - y\right)(R_z - \Delta_x - \Delta_y) + z(R_y + \Delta_z) + \\ & \left(\frac{\pi}{2} - y\right)(R_z - \Delta_x + \Delta_y) + z(R_y - \Delta_z) \end{aligned}$$

[0119] This equation simplifies to:

$$T_x = 4 \left[ \left( -\frac{3\pi}{2} \sin(y)\cos(y) + z \right) R_y + \left( \frac{3\pi}{2} \sin^2(y) - \pi - y \right) R_z - \frac{3\pi}{2} \Delta_x \right]$$

[0120] Torque About the Y-axis

[0121] Similarly, the torque about the Y-axis can be found from:

$$T_y = \Sigma t_y + \Sigma (q_z f_x - q_x f_z) \quad (3)$$

[0122] The first term  $\Sigma t_y$  is the Y-axis torque about the origin of each coil group. The Y-axis torque for each coil group can be expressed by:

$$t_{y1} = \frac{3\pi}{2} [\sin(x)\cos(x)(R_x) + \sin^2(x)(R_z + \Delta_x - \Delta_y)]$$

$$t_{y2} = \frac{3\pi}{2} [\sin(x)\cos(x)(R_x) + \sin^2(x)(R_z + \Delta_x + \Delta_y)]$$

$$t_{y3} = \frac{3\pi}{2} [\sin(x)\cos(x)(R_x) + \sin^2(x)(R_z - \Delta_x - \Delta_y)]$$

$$t_{y4} = \frac{3\pi}{2} [\sin(x)\cos(x)(R_x) + \sin^2(x)(R_z - \Delta_x + \Delta_y)]$$

[0123] Summing these four equations results in the first term  $\Sigma t_y$  of the total torque equation:

$$\sum t_y = 4 \frac{3\pi}{2} (\sin(x)\cos(x)R_x - \sin^2(x)R_z)$$

[0124] Substituting the position vector  $q$  and force vector  $r$  components from Table IV into equation (3) results in the following total Y-axis torque equation:

$$\begin{aligned} T_y = & \sum t_y - zR_x + \left(\frac{5\pi}{2} + x\right)(R_z + \Delta_x - \Delta_y) - \\ & zR_x + \left(\frac{-\pi}{2} + x\right)(R_z + \Delta_x + \Delta_y) - \\ & zR_x + \left(\frac{5\pi}{2} + x\right)(R_z - \Delta_x - \Delta_y) - \\ & zR_x + \left(\frac{-\pi}{2} + x\right)(R_z - \Delta_x + \Delta_y) \end{aligned}$$

[0125] This equation simplifies to:

$$T_y = 4 \left[ \left( \frac{3\pi}{2} \sin(x)\cos(x) - z \right) R_x + \left( \frac{-3\pi}{2} \sin^2(x) + \pi + x \right) R_z - \frac{3\pi}{2} \Delta_y \right]$$

[0126] Torque About the Z-axis

[0127] Similarly, the torque about the Z-axis can be found from:

$$T_z = \Sigma t_z + \Sigma (q_x f_y - q_y f_x) \quad (4)$$

[0128] The first term  $\Sigma t_z$  is the Z-axis torque about the origin of each coil group. The Z-axis torque for each coil group can be expressed by:

$$t_{z1} = \frac{3\pi}{2} [-\sin^2(y)R_x + \sin^2(x)(R_y + \Delta_z)]$$

$$t_{z2} = \frac{3\pi}{2} [-\sin^2(y)R_x + \sin^2(x)(R_y - \Delta_z)]$$

$$t_{z3} = \frac{3\pi}{2} [-\sin^2(y)R_x + \sin^2(x)(R_y + \Delta_z)]$$

$$t_{z4} = \frac{3\pi}{2} [-\sin^2(y)R_x + \sin^2(x)(R_y - \Delta_z)]$$

[0129] Summing these four equations results in the first term  $\Sigma t_z$  of the total torque equation:

$$\sum t_z = 4 \frac{3\pi}{2} (-\sin^2(y)R_x + \sin^2(x)R_y)$$

[0130] Substituting the position vector  $q$  and force vector  $r$  components from Table IV into equation (4) results in the following total Z-axis torque equation:

$$T_z = \sum I_z + \left(\frac{-5\pi}{2} - x\right)(R_y + \Delta_z) + \left(\frac{5\pi}{2} + y\right)R_x + \left(\frac{\pi}{2} - x\right)(R_y + \Delta_z) + \left(\frac{5\pi}{2} + y\right)R_x + \left(\frac{-5\pi}{2} - x\right)(R_y + \Delta_z) + \left(\frac{-\pi}{2} + y\right)R_x + \left(\frac{\pi}{2} - x\right)(R_y + \Delta_z) + \left(\frac{-\pi}{2} + y\right)R_x$$

[0131] This equation simplifies to:

$$T_z = 4 \left[ \left(\frac{-3\pi}{2} \sin^2(y) + \pi + y\right)R_x + \left(\frac{3\pi}{2} \sin^2(x) - \pi - x\right)R_y - \frac{3\pi}{2} \Delta_z \right]$$

[0132] Input-Output Matrix for the Stage

[0133] Combining the three equations for total torque  $T_x$ ,  $T_y$ , and  $T_z$  with the total force  $F_x$ ,  $F_y$ , and  $F_z$  produced by the stage gives the following equation that represents the input-output behavior of the entire stage:

$$\begin{pmatrix} F_x \\ F_y \\ F_z \\ T_x \\ T_y \\ T_z \end{pmatrix} = 4 \begin{pmatrix} 1 & 0 & 0 & 0 & 0 & 0 \\ 0 & 1 & 0 & 0 & 0 & 0 \\ 0 & 0 & 1 & 0 & 0 & 0 \\ 0 & \frac{-3\pi}{2} \sin(y)\cos(y) + z & \left(\frac{3\pi}{2} \sin^2(y)\right) & \frac{-3\pi}{2} & 0 & 0 \\ \frac{3\pi}{2} \sin(x)\cos(x) - z & 0 & \left(\frac{-3\pi}{2} \sin^2(x)\right) & 0 & \frac{-3\pi}{2} & 0 \\ \left(\frac{-3\pi}{2} \sin^2(y)\right) & \left(\frac{3\pi}{2} \sin^2(x)\right) & 0 & 0 & 0 & \frac{-3\pi}{2} \end{pmatrix} \begin{pmatrix} R_x \\ R_y \\ R_z \\ \Delta_x \\ \Delta_y \\ \Delta_z \end{pmatrix}$$

[0134] The equation can be rewritten as:

$$Y=AU$$

[0135] Matrix A is:

$$A = \begin{pmatrix} 4 & 0 & 0 & 0 & 0 & 0 \\ 0 & 4 & 0 & 0 & 0 & 0 \\ 0 & 0 & 4 & 0 & 0 & 0 \\ x & x & x & -6\pi & 0 & 0 \\ x & x & x & 0 & -6\pi & 0 \\ x & x & x & 0 & 0 & -6\pi \end{pmatrix}$$

[0136] The “x” terms of matrix A are terms that depend only on the stage position. The total force produced by the stage depends only on the desired force vector ( $R_x$ ,  $R_y$ ,  $R_z$ ). Although the force vector affects the torque generated, the correction terms  $\Delta_x$ ,  $\Delta_y$ ,  $\Delta_z$  can be used to generate desired and/or predetermined torques.

[0137] Torque Compensation

[0138] The method of the invention for independently controlling the forces and torque generated by the electric motor in six degrees of freedom preferably includes determining the uncompensated torque about the X, Y, and Z axis generated from the commutation scheme using the desired force vector  $R$  and then determining the correction terms  $\Delta_x$ ,  $\Delta_y$ ,  $\Delta_z$  that make the total torque equal the desired value. The uncompensated torque about the X, Y, and Z axis generated from the commutation scheme may be determined using force vector terms  $R_x$ ,  $R_y$ ,  $R_z$  and the lower-left nine elements of matrix A. The correction terms  $\Delta_x$ ,  $\Delta_y$ ,  $\Delta_z$  may be determined by dividing the desired torque minus the uncompensated torque about the X, Y, and Z axis by 6i. The torque-compensated commutation equations thus uses the terms  $R_x$ ,  $R_y$ ,  $R_z$ ,  $\Delta_x$ ,  $\Delta_y$ , and  $\Delta_z$ .

[0139] FIG. 10 is a flow chart illustrating the process or method 250 of achieving motion of the magnet array 24 with respect to the coil array 22. The method or process 250 begins at a start procedure 252. Procedure 254 positions the magnet array 24 relative to the coil array 22. Procedure 256 determines the position of the magnet array 24 relative to the coil array 22 with the use of a measurement device such as an interferometer. Procedure 258 energizes the active coils of the coil array 22 according to the commutation scheme as determined with the method described above. Procedure 260

determines whether a stop condition exists. If not, the method 250 returns to procedure 256 to determine the position of the magnet array 24 relative to the coil array 22. If it is time to stop the motor, the method 250 terminates at a procedure 262.

[0140] Procedure 258 controls the relative forces between a portion of the coil array and the moving magnet array by selectively applying predetermined currents to the appropriate coils such that the appropriate coils interact with the magnetic fields associated with the magnets in the magnet array and generate Lorentz forces.

[0141] As noted, the above-described method of independently controlling a moving magnet planar electric motor to position the platform in six degrees of freedom may be utilized with a moving coil electric motor. However, the commutation scheme is simpler because all the coils of the moving coil array are within the magnet field of the magnet array and no coils are partially within the magnet field. Thus, the forces generated between the coil and magnet arrays act

through the center of the coils given that the coils are always in the same position relative to the center of gravity of the moving coil array or stage. Therefore, torque control is straightforward in a moving coil planar electric motor.

[0142] The electric motors of the invention may be used with a lithography system such as shown and described in, for example, the '118 patent referenced above. FIG. 11 shows a schematic side view of an example of a photolithography system 800 using the electric motor 812 of the invention. Although the photolithography system 800 is described as utilizing a moving magnet electric motor 812, the photolithography system may be adapted to utilize a moving coil electric motor or other variations of the moving magnet electric motor.

[0143] The photolithography system (exposure apparatus) 800 generally comprises an illumination system 802 (irradiation apparatus), a first frame 834, a reticle stage assembly 810, a second frame 832, the optical assembly (lens assembly) 804, a third frame 826, and a wafer stage assembly 820. A moving magnet electric motor 812 provided herein can be used as a part of the wafer stage assembly 820. Alternately, with the disclosure provided herein, the moving magnet electric motor 812 can be modified for use as a part of the reticle stage assembly 810.

[0144] The lithography system 800 is particularly useful as a lithographic device that transfers a pattern (not shown) of an integrated circuit from a reticle 806 onto a substrate such as a semiconductor wafer 808. The lithography system 800 mounts to the mounting base 850, e.g., the ground, a base, or floor or some other supporting structure.

[0145] The first frame 834 supports the illumination system 802 above the mounting base 850. The second frame 832 supports the reticle stage assembly 810 above the mounting base 850. The third frame 826 supports the optical assembly 804 above the mounting base 850. The frames 834, 832, and 826 are coupled to the mounting base 850 by vibration damping devices 860. The design of these frames 834, 832, and 826 can be varied to suit the design requirements for the rest of the lithography system 800.

[0146] The illumination system includes an illumination source 851 and an illumination optical assembly 852. The illumination source 851 emits a beam (irradiation) of light energy. The illumination optical assembly 852 guides the beam of light energy from the illumination source 851 to the optical assembly 804. The beam illuminates selectively different portions of the reticle 806 and exposes the wafer 808. In FIG. 8, the illumination system 802 is illustrated as being supported above the reticle stage assembly 810. However, the illumination system 802 is secured to one of the sides of the frames and the energy beam from the illumination source 851 is directed to above the reticle stage assembly 810 with the illumination optical assembly 852.

[0147] The optical assembly 804 projects and/or focuses the light passing through the reticle 806 to the wafer 808. Depending upon the design of the lithography system 800, the optical assembly 804 can magnify or reduce the image illuminated on the reticle 806.

[0148] The reticle stage assembly 810 holds and positions the reticle 806 relative to the optical assembly 804 and the wafer 808. Similarly, the wafer stage assembly 820 holds and positions the wafer 808 with respect to the projected

image of the illuminated portions of the reticle 806 in the operation area. In FIG. 8, the wafer stage assembly 820 utilizes the moving magnet electric motor 812 having features of the present invention. Depending upon the design, the lithography system 800 can also include additional wafer stage assemblies 820 to increase the throughput of the lithography system 800.

[0149] The wafer 808 is held by vacuum suction on a wafer holder 849 that is supported on the wafer stage assembly 820. The wafer stage assembly 820 is structured so that it can be moved in several (e.g., three to six) degrees of freedom by a planar motor (the moving magnet electric motor 812) under precision control by a wafer stage driver 853 and system controller 855, to position the wafer 808 at a desired position and orientation, and to move the wafer 808 relative to the projected image of the illuminated portions of the reticle 806 in the operation area. The moving magnet electric motor 812 comprises a moving magnet array 814 and a fixed coil array 818. The moving magnet array 814 is connected to the wafer holder 849 and supported by air bearings 816 on a plate 836. The plate 836 is positioned between the moving magnet array 814 and the fixed coil array 818 and connected to the third frame 826. The plate 826 may be made of non-magnetic materials, for example, carbon fiber plastics, ceramics such as Zerodur ceramics, Al<sub>2</sub>O<sub>3</sub> ceramics, and like materials that do not impair the magnetic flux generated by the magnet array 814. The plate 836 may be formed with a thick honeycomb structure or other types of reinforced structure to prevent it from bending. The coil array 818 is attached to the backing panel 822. The backing panel 822 is rigidly supported on the mounting base 850 on support 861. However, the backing panel 822 may be supported on the mounting base 850 by the vibration damping device 860 same as the frames 834, 832, and 826.

[0150] The lithography system 800 includes a first measuring system that detects the position of the wafer holder 849 (wafer 808) relative to the optical assembly 804 as a reference structure at least along the X, Y axis and about the Z (theta Z) axis. This information corresponds to the position of the magnet array 814 relative to the coil array 818. The first measuring system can utilize an interferometer system. In this embodiment, the first measuring system comprises a first interferometer block 856 supported on the third frame 826 and a first moving mirror 857 attached to the wafer holder 849. The first interferometer block 856 generates a pair of spaced apart laser beams (not shown) to the first moving mirror 857 and detects the beams reflected from the first moving mirror 857 to output the information of the position of the wafer 808 to the system controller 855. Further, the lithography system 800 includes a second measuring system that detects the position of the reticle stage assembly 810 (reticle 806) relative to the optical assembly 804 as a reference structure at least along the X, Y axis and about the Z (theta Z) axis. Somewhat similarly, the second measuring system comprises a second interferometer block 858 supported on the third frame 826 and a second moving mirror 859 attached to the reticle stage assembly 810. The second interferometer block 858 generated a pair of spaced apart laser beam (not shown) to the second moving mirror 859 and detects the beams reflected from the second moving mirror 859 to output the information of the position of the reticle 806 to the system controller 855.



[0151] The system controller **855** is connected to the first interferometer block **856**, the second interferometer block **858**, the wafer stage driver **853**, and a reticle stage driver **854**. The system controller **855** controls each of drivers **854** and **853** for the reticle stage assembly **810** and wafer stage assembly **820** based on the information of the positions outputted from the interferometer blocks **856** and **858** and the desired position of the reticle and the wafer stage assemblies. In this embodiment, the system controller **855** determines current to be applied to coils included in the coil array **818** of the electric motor **812**, and outputs this information to the wafer stage driver **853**. The wafer stage driver **853** is connected to each coil of the coil array **818** and drives the electric motor **812** in accordance with the information. Further, the system controller **855** determines a resultant torque between the magnet array **814** and the coil array **818** and the correction current to compensate for the resultant torque as mentioned above. The wafer stage driver **853** drives the electric motor **812** based on this information. As a result, the wafer **808** is positioned precisely in wide ranges.

[0152] The electric motor **812** can be structured as the moving coil planar motor such as shown in FIGS. 3 and 4.

[0153] There are a number of different types of photolithographic devices. For example, photography system **800** can be used as a scanning type photolithography system which exposes the pattern from reticle **806** onto wafer **808** with reticle **806** and wafer **808** moving synchronously. In a scanning type lithographic device, reticle **806** is moved perpendicular to an optical axis of lens assembly **804** by reticle stage assembly **810** and wafer **808** is moved perpendicular to an optical axis of lens assembly **804** by wafer stage assembly **820**. Scanning of reticle **806** and wafer **808** occurs while reticle **806** and wafer **808** are moving synchronously.

[0154] Alternately, photolithography system **800** can be a step-and-repeat type photolithography system that exposes reticle **806** while reticle **806** and wafer **808** are stationary. In the step and repeat process, wafer **808** is in a constant position relative to reticle **806** and lens assembly **804** during the exposure of an individual field. Subsequently, between consecutive exposure steps, wafer **808** is consecutively moved by wafer stage assembly **820** perpendicular to the optical axis of lens assembly **804** so that the next field of semiconductor wafer **808** is brought into position relative to lens assembly **804** and reticle **806**.

[0155] However, the use of photolithography system **800** provided herein is not limited to a photolithography system for a semiconductor manufacturing. Photolithography system **800**, for example, can be used as an LCD photolithography system that exposes a liquid crystal display device pattern onto a rectangular glass plate or a photolithography system for manufacturing a thin film magnetic head. Further, the present invention can also be applied to a proximity photolithography system that exposes a mask pattern by closely locating a mask and a substrate without the use of a lens assembly. Additionally, the present invention provided herein can be used in other devices, including other semiconductor processing equipment, machine tools, metal cutting machines, and inspection machines.

[0156] The illumination source **851** can be g-line (436 nm), i-line (365 nm), KrF excimer laser (248 nm), ArF excimer laser (193 nm) and F<sub>2</sub> laser (157 nm). Alternatively,

illumination source **851** can also use charged particle beams such as x-ray and electron beam. For instance, in the case where an electron beam is used, thermionic emission type lanthanum hexaboride (LaB<sub>6</sub>) or tantalum (Ta) can be used as an electron gun. Furthermore, in the case where an electron beam is used, the structure could be such that either a mask is used or a pattern can be directly formed on a substrate without the use of a mask.

[0157] With respect to lens assembly **804**, when far ultraviolet rays such as the excimer laser is used, glass materials such as quartz and fluorite that transmit far ultraviolet rays is preferably used. When the F<sub>2</sub> type laser or x-ray is used, lens assembly **804** should preferably be either catadioptric or refractive (a reticle should also preferably be a reflective type), and when an electron beam is used, electron optics should preferably comprise electron lenses and deflectors. The optical path for the electron beams should be in a vacuum.

[0158] Also, with an exposure device that employs vacuum ultra-violet radiation (VUV) of wavelength 200 nm or lower, use of the catadioptric type optical system can be considered. Examples of the catadioptric type of optical system include the disclosure Japan Patent Application Disclosure No. 8-171054 published in the Official Gazette for Laid-Open Patent Applications and its counterpart U.S. Patent No. 5,668,672, as well as Japan Patent Application Disclosure No. 10-20195 and its counterpart U.S. Pat. No. 5,835,275. In these cases, the reflecting optical device can be a catadioptric optical system incorporating a beam splitter and concave mirror. Japan Patent Application Disclosure No. 8-334695 published in the Official Gazette for Laid-Open Patent Applications and its counterpart U.S. Pat. No. 5,689,377 as well as Japan Patent Application Disclosure No. 10-3039 and its counterpart U.S. Pat. No. 873,606 (Application Date: Jun. 12, 1997) also use a reflecting-refracting type of optical system incorporating a concave mirror, etc., but without a beam splitter, and can also be employed with this invention. The disclosures in the above-mentioned U.S. patents, as well as the Japan patent applications published in the Official Gazette for Laid-Open Patent Applications are incorporated herein by reference.

[0159] Further, in photolithography systems, when linear motors (see U.S. Pat. Nos. 5,623,853 or 5,528,118) are used in a wafer stage or a reticle stage, the linear motors can be either an air levitation type employing air bearings or a magnetic levitation type using Lorentz force or reactance force. Additionally, the stage could move along a guide, or it could be a guideless type stage which uses no guide. The disclosures in U.S. Pat. Nos. 5,523,853 and 5,528,118 are incorporated herein by reference.

[0160] Alternately, one of the stages could be driven by a planar motor, which drives the stage by electromagnetic force generated by a magnet unit having two-dimensionally arranged magnets and an armature coil unit having two-dimensionally arranged coils in facing positions. With this type of driving system, either one of the magnet unit or the armature coil unit is connected to the stage and the other unit is mounted on the moving plane side of the stage.

[0161] Movement of the stages as described above generates reaction forces which can affect performance of the photolithography system. Reaction forces generated by the wafer (substrate) stage motion can be mechanically released

to the floor (ground) by use of a frame member as described in U.S. Pat. No. 5,528,118 and published Japanese Patent Application Disclosure No. 8-166475. Additionally, reaction forces generated by the reticle (mask) stage motion can be mechanically released to the floor (ground) by use of a frame member as described in U.S. Pat. No. 5,874,820 and published Japanese Patent Application Disclosure No. 8-330224. The disclosures in U.S. Pat. Nos. 5,528,118 and 5,874,820 and Japanese Patent Application Disclosure No. 8-330224 are incorporated herein by reference.

[0162] As described above, a photolithography system according to the above described embodiments can be built by assembling various subsystems, including each element listed in the appended claims, in such a manner that prescribed mechanical accuracy, electrical accuracy and optical accuracy are maintained. In order to maintain the various accuracies, prior to and following assembly, every optical system is adjusted to achieve its optical accuracy. Similarly, every mechanical system and every electrical system are adjusted to achieve their respective mechanical and electrical accuracies. The process of assembling each subsystem into a photolithography system includes mechanical interfaces, electrical circuit wiring connections and air pressure plumbing connections between each subsystem. Needless to say, there is also a process where each subsystem is assembled prior to assembling a photolithography system from the various subsystems, total adjustment is performed to make sure that every accuracy is maintained in the complete photolithography system. Additionally, it is desirable to manufacture an exposure system in a clean room where the temperature and humidity are controlled.

[0163] Further, semiconductor devices can be fabricated using the above described systems, by the process shown generally in FIG. 12. In step 401 the device's function and performance characteristics are designed. Next, in step 402, a mask (reticle) having a pattern is designed according to the previous designing step, and in a parallel step 403, a wafer is made from a silicon material. The mask pattern designed in step 402 is exposed onto the wafer from step 403 in step 404 by a photolithography system described hereinabove consistent with the principles of the present invention. In step 405 the semiconductor device is assembled (including the dicing process, bonding process and packaging process), then finally the device is inspected in step 406.

[0164] FIG. 13 illustrates a detailed flowchart example of the above-mentioned step 404 in the case of fabricating semiconductor devices. In step 411 (oxidation step), the wafer surface is oxidized. In step 412 (CVD step), an insulation film is formed on the wafer surface. In step 413 (electrode formation step), electrodes are formed on the wafer by vapor deposition. In step 414 (ion implantation step), ions are implanted in the wafer. The above mentioned steps 411-414 form the preprocessing steps for wafers during wafer processing, and selection is made at each step according to processing requirements.

[0165] At each stage of wafer processing, when the above-mentioned preprocessing steps have been completed, the following post-processing steps are implemented. During post-processing, initially, in step 415 (photoresist formation step), photoresist is applied to a wafer. Next, in step 416, (exposure step), the above-mentioned exposure device is used to transfer the circuit pattern of a mask (reticle) to a

wafer. Then, in step 417, (developing step), the exposed wafer is developed, and in step 418 (etching step), parts other than residual photoresist (exposed material surface) are removed by etching. In step 419 (photoresist removal step), unnecessary photoresist remaining after etching is removed.

[0166] Multiple circuit patterns are formed by repetition of these preprocessing and post-processing steps.

[0167] It will be apparent to those skilled in the art that various modifications and variations can be made in the methods described, in the stage device, the control system, the material chosen for the present invention, and in construction of the photolithography systems as well as other aspects of the invention without departing from the scope or spirit of the invention.

[0168] Although only a few exemplary embodiments of this invention have been described in detail above, those skilled in the art will readily appreciate that many modifications are possible in the exemplary embodiments without materially departing from the novel teachings and advantages of this invention. For example, although depicted as being planar, the arrays of magnetic poles and coils can have either constant or varying curvature in one or two-dimensions as in cylindrical, toroidal, and spherical arrangements of magnetic poles and coils. For cylindrical arrangements, latitudinal and longitudinal directions may be defined, for example, in standard cylindrical coordinates with corresponding diagonal directions, and parallel arrays and coils lie on parallel surfaces. Accordingly, all such modifications are intended to be within the scope of the following claims.

What is claimed is:

1. A method for controlling a planar electric motor comprising a magnet array having a magnets with magnetic fields and a coil array comprising coils generally disposed in a plane, for positioning in six degrees of freedom, comprising:

determining currents to be applied to coils to generate forces between the magnet array and the coil array in first, second, and third directions, the first and second directions lying in the plane and being generally orthogonal to each other and the third direction being generally orthogonal to the first and second directions;

determining resultant torques about the first, second, and third directions between the magnet array and the coil array generated by the forces generated by the determined currents;

determining current adjustments to compensate for the resultant torques; and

applying a sum of the determined currents and determined current adjustments to the coils to interact with the magnetic fields of the magnet array to control the planar electric motor.

2. The method of claim 1, further comprising determining a relative position of the magnet array with respect to the coil array and using said determined position to determine said currents, said resultant torque or said current adjustments.

3. The method of claim 1, wherein the currents to be applied to coils in the portion of the coil array are sinusoidal, triangular or square waveforms.

4. The method of claim 1, further comprising determining forces generated between the magnet array and the coil array in the first, second, and third directions to result in forces in the first, second, third directions and/or about the first, second and third directions.

5. The method of claim 1, wherein the current adjustments are determined for each coil in a predetermined portion of the coil array.

6. The method of claim 1, wherein currents to be applied to the coils is determined only for coils in a predetermined portion of the coil array.

7. The method of claim 1, wherein the sum of the currents and current adjustments to the coils is applied only to coils in a predetermined portion of the coil array.

8. The method of claim 7, wherein the coils in the predetermined portion of the coil array includes coils partially within the magnetic fields of the magnet array.

9. The method of claim 1, wherein the coils in the portion of the coil array comprises twenty-five or fewer coils.

10. The method of claim 1, wherein the coils in the portion of the coil array comprises twelve or more coils.

11. The method of claim 1, wherein the coils in the portion of the coil array comprises sixteen or more coils.

12. A method for determining current to be applied to control a planar electric motor in six degrees of freedom, the motor having a magnet array and a coil array having coils generally disposed in a plane, comprising:

determining currents to be applied to coils to generate forces between the magnet array and the coil array in first, second, and third directions, the first and second directions lying in the plane and being generally orthogonal to each other and the third direction being generally orthogonal to the first and second directions, the currents being dependent upon the position of the magnet array and desired forces in the first, second, and third directions or about the first, second, and third directions;

determining resultant torques generated by the determined currents; and

determining current adjustments to be added to the determined currents to compensate for the resultant torques.

13. The method of claim 12, further comprising determining a sum of the currents and current adjustments.

14. The method of claim 12, wherein the currents are determined only for coils in a portion of the coil array within a magnetic field of the magnet array.

15. The method of claim 14, wherein the coils in the portion of the coil array include coils partially within the magnetic fields of the magnet array.

16. The method of claim 12, wherein the determining the currents to be applied to the coils comprises determining the currents to be applied to twenty-five or fewer coils.

17. The method of claim 12, wherein determining the currents comprising determining the currents to be applied to twelve or more coils.

18. A method for positioning an object in a lithography system, comprising:

providing a frame;

providing a stage for supporting the object and movable to position the object relative to the frame in six degrees of freedom;

providing a coil array attached to the frame, the coil array having coils;

providing a magnet array adjacent a portion of the coil array, the magnet array being attached to the stage and having magnets generally disposed in a plane, the plane defining a first and second direction;

determining currents to be applied to coils in the portion of the coil array to generate forces between the magnet array and the coil array in the first, second, and third directions;

determining a resultant torque between the magnet array and the coil array generated by the forces;

determining current adjustments to compensate for the resultant torque; and

applying a sum of the determined currents and determined current adjustments to the coils to interact with magnetic fields of the magnet array.

19. The method of claim 18, further comprising determining a position of the magnet array relative to the coil array and using the position of the magnet array in determining currents, resultant torque or current adjustments.

20. The method of claim 18, wherein currents to be applied to coils in the portion of the coil array are sinusoidal, triangular or square waveforms.

21. The method of claim 18, further comprising determining forces to be generated between the magnet array and the coil array in the first, second, and third directions to result in forces in the first, second, and third directions or torques about the first, second, and third directions.

22. The method of claim 18, wherein the current adjustments are determined for each coil in the portion of the coil array.

23. The method of claim 18, wherein currents to be applied to the coils are determined only for coils in the portion of the coil array.

24. The method of claim 18, wherein the sum of the determined currents and determined current adjustments to the coils is applied only to coils in the portion of the coil array.

25. The method of claim 24, wherein the coils in the portion of the coil array include coils partially within the magnetic fields of the magnet array.

26. The method of claim 18, wherein the coils in the portion of the coil array comprise twenty-five or fewer coils.

27. The method of claim 18, wherein the coils in the portion of the coil array comprise twelve or more coils.

28. The method of claim 18, wherein the coils in the portion of the coil array comprise sixteen or more coils.

29. A method for determining current to be applied to control a planar electric motor in six degrees of freedom, the motor having a magnet array and a coil array having coils generally disposed in a plane, comprising:

determining a position of the magnet array relative to the coil array in the X, Y, and Z directions, the X and Y directions being defined by the plane and the Z direction being generally orthogonal to the X and Y directions;

determining desired forces  $R_x$ ,  $R_y$ , and  $R_z$  in the X, Y, and Z directions, respectively, for independently control-

ling the magnet array to move relative to the coil array in the X, Y, and Z directions or about the X, Y, and Z directions;

determining currents to be applied to the coils for generating the desired forces  $R_x$ ,  $R_y$ , and  $R_z$  between the magnet array and the coil array;

determining a resultant torque generated by the currents according to the position of the magnet array relative to the coil array and to the desired forces  $R_x$ ,  $R_y$ , and  $R_z$ ; and

determining current corrections  $\Delta_x$ ,  $\Delta_y$ ,  $\Delta_z$  to be added to the currents, to produce torques  $T_x$ ,  $T_y$ ,  $T_z$ ;

wherein resultant the forces  $F_x$ ,  $F_y$ ,  $F_z$  are equal to the desired forces  $R_x$ ,  $R_y$ , and  $R_z$ , and the resultant torques  $T_x$ ,  $T_y$ ,  $T_z$  equal desired values.

**30.** A method for making a wafer utilizing the positioning method of claim 18.

**31.** A method for making a device including at least an exposure process, wherein the exposure process uses the lithography system utilizing the method of claim 18.

**32.** A planar motor comprising:

a first member;

a second member that interacts with the first member to generate driving force, the second member being movable relative to the first member in six degrees of freedom including a first, second, and third directions by the driving force; and

a controller connected to at least one of the first member and second member, the controller determining information related to resultant torque about the first, second and third directions between the first member and the second member generated by the driving force.

**33.** The planar motor of claim 32, further comprising a measuring system connected to the controller, the measuring system detecting information related to the relative position between the first member and the second member; and wherein the controller determines the resultant torque based on the information related to the relative position between the first member and the second member.

**34.** The planar motor of claim 32, wherein the controller determines the information that is utilized to compensate for the resultant torque.

**35.** The planar motor of claim 34, wherein the controller outputs the information to at least one of the first member and second member to generate force for compensation of the resultant torque.

**36.** The planar motor of claim 32, wherein the driving force is generated by utilizing a Lorentz force.

**37.** The planar motor of claim 32, wherein the first member includes a magnet array having magnets and the second member includes a coil array having coils generally disposed in a plane, the plane defining a first and second direction and the direction of the driving force is substantially the same as the first and second direction.

**38.** The planar motor of claim 37, wherein the controller determines current adjustment to compensate for the resultant torque.

**39.** A stage assembly including the planar motor of claim 32.

**40.** A lithography system including the stage assembly of claim 39.

**41.** A device manufactured with the stage assembly of claim 39.

**42.** A wafer on which an image has formed by the lithography system of claim 40.

\* \* \* \* \*