



US 20220402558A1

(19) **United States**

(12) **Patent Application Publication**
Brandley et al.

(10) **Pub. No.: US 2022/0402558 A1**

(43) **Pub. Date: Dec. 22, 2022**

(54) **MODULAR STRUCTURAL COMPOSITES FOR AUTOMOTIVE APPLICATIONS**

Publication Classification

(71) Applicant: **Bridgestone Americas, Inc.**, Nashville, TN (US)

(51) **Int. Cl.**
B62D 25/20 (2006.01)
B62D 29/04 (2006.01)
(52) **U.S. Cl.**
CPC *B62D 25/20* (2013.01); *B62D 29/043* (2013.01); *B62D 29/048* (2013.01)

(72) Inventors: **Mark W. Brandley**, Franklin, TN (US); **Georg Kasmeier**, Munich (DE); **Adam Halsband**, Birmingham, MI (US); **Adam Harms**, St. Louis, MO (US); **Johannes Klug**, Munich (DE)

(57) **ABSTRACT**

(21) Appl. No.: **17/812,197**

A modular composite structure containing multiple individual composite structures attached together. The individual composite structures form sections of a vehicle component. The composite structures are lightweight and made of materials that can function to absorb energy or attenuate vibration or noise. The composite structures contain a core material adhered to a fiber layer and a fiber reinforcement region for improving the strength and stiffness of the modular composite structure. The modular composite structure can include multiple floor pan segments that can be attached to a central composite structure that can be a utility tunnel or housing.

(22) Filed: **Jul. 13, 2022**

Related U.S. Application Data

(63) Continuation of application No. 17/258,081, filed on Jan. 5, 2021, now Pat. No. 11,479,305, filed as application No. PCT/US2019/043220 on Jul. 24, 2019.

(60) Provisional application No. 62/702,428, filed on Jul. 24, 2018.

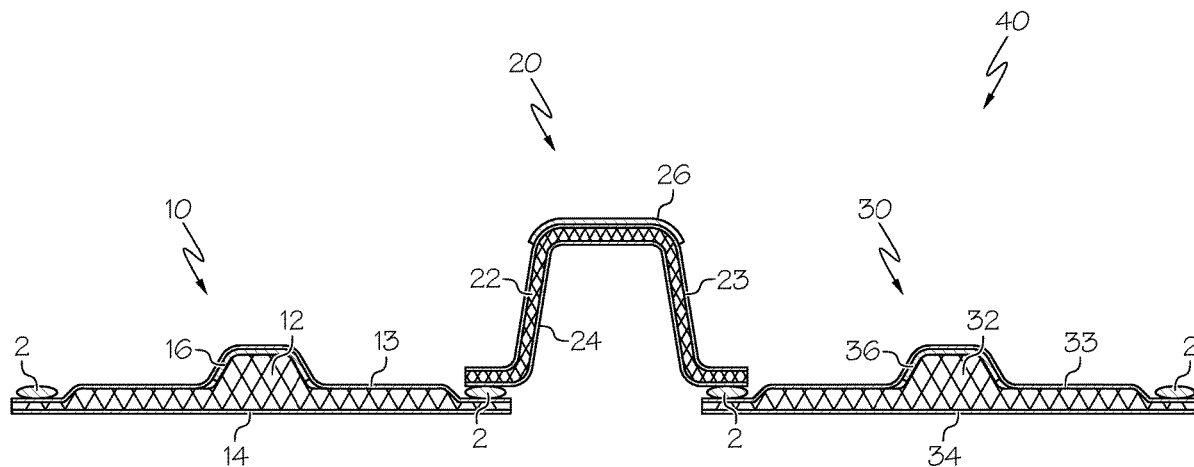

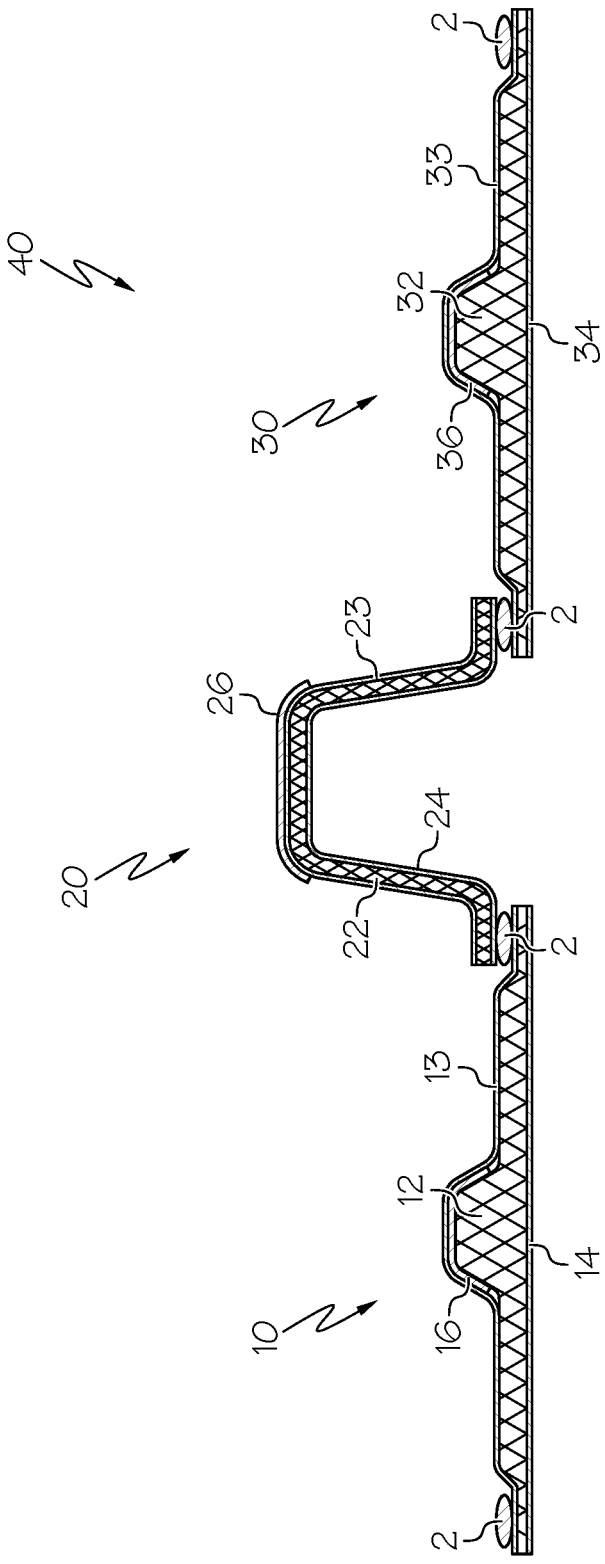

FIG. 1

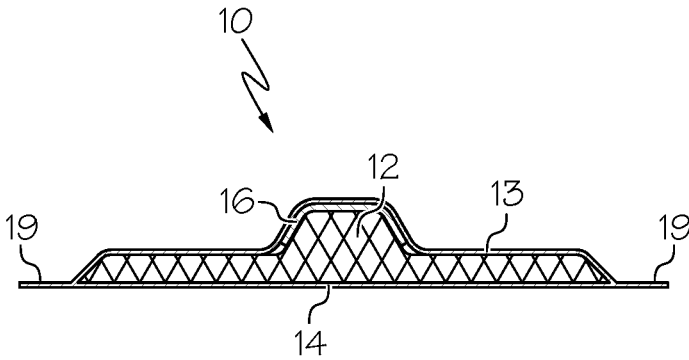

FIG. 2

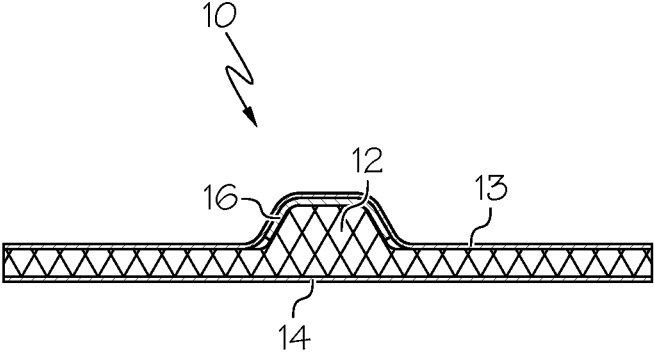

FIG. 3

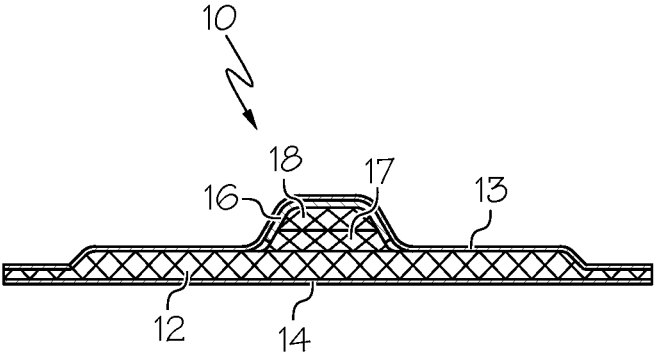

FIG. 4

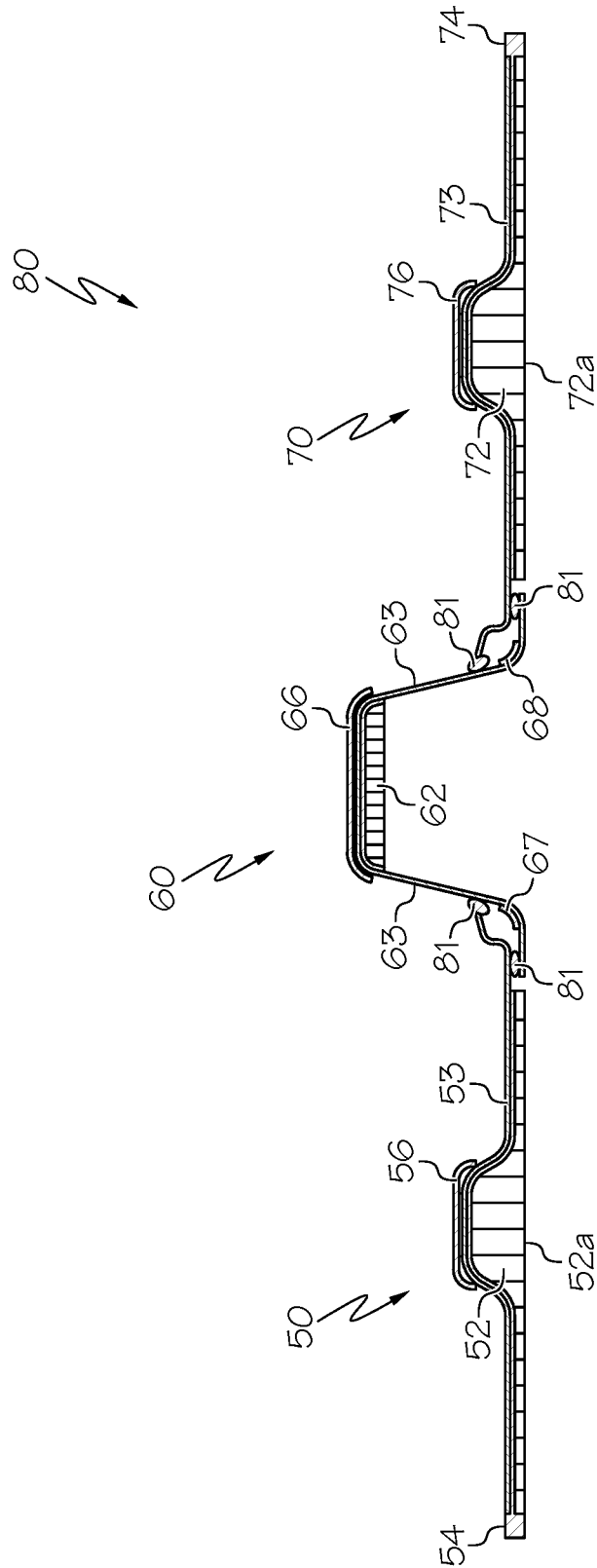

FIG. 5

MODULAR STRUCTURAL COMPOSITES FOR AUTOMOTIVE APPLICATIONS

CROSS-REFERENCE TO RELATED APPLICATIONS

[0001] This application claims the benefit of U.S. provisional application Ser. No. 62/702,428 filed Jul. 24, 2018, International application No. PCT/US2019/043220 filed Jul. 24, 2019, and U.S. application Ser. No. 17/258,081 filed Jan. 5, 2021, all of which are incorporated herein by reference.

TECHNICAL FIELD

[0002] The present disclosure relates to modular structural composites for use as vehicle parts and, in particular, to modular, reinforced structural composites for use as a segmented floor pan and utility tunnel in a vehicle.

BACKGROUND

[0003] Composite structures that utilize many different materials are used in a variety of applications that warrant increased strength, such as high bending stiffness, and reduced weight. Automotive applications employ composite materials to reduce vehicle weight and provide desirable stiffness to body parts and panels. Materials often used in the composite structures include reinforcing fibers, resins and plastics. For example, motor vehicle floor designs can include molded compounds that include thermosetting plastic material having reinforcing fibers such as glass fibers mixed in.

[0004] There exists a need among automotive manufacturers for structural composites that are stiff enough to resist bending yet strong enough to absorb energy without increasing part weight. It is also desirable that the structural composites are easily manufactured at a relatively low cost. The present invention employs a combination of materials that provide a lightweight design that effectively attenuates vibration and sound, is strong enough to resist bending and can absorb energy in a controlled manner.

SUMMARY

[0005] In a first aspect, disclosed is a modular composite structure that includes a first molded composite core structure having a first surface, the first surface of the first molded composite core structure being bonded to a first fiber layer embedded in a first polymer, and a first fiber reinforcement region overlying a portion of the first surface of the first molded composite core structure. The modular composite structure further includes a second molded composite core structure having a first fiber substrate, the first fiber substrate including fibers embedded in a second polymer, the first fiber substrate being bonded to a first surface of the second molded composite core structure, and a second fiber reinforcement region being bonded to and overlying a portion of the first fiber substrate, wherein the first molded composite core structure is attached to the second molded composite core structure.

[0006] In an example of aspect 1, the first molded composite core structure includes a central area of increased thickness along its length, and the first fiber reinforcement region overlies the central area of increased thickness of the molded composite core structure.

[0007] In another example of aspect 1, the first fiber reinforcement region is embedded in the first polymer and

the second fiber reinforcement region is embedded in the second polymer, wherein the first polymer and the second polymer can be the same material.

[0008] In another example of aspect 1, the first fiber reinforcement region overlies the first fiber layer, and a portion of the first fiber layer is in direct contact with the first molded composite core structure.

[0009] In another example of aspect 1, the first fiber layer overlies the first fiber reinforcement region such that a portion of the first fiber reinforcement region is in direct contact with the first molded composite core structure.

[0010] In another example of aspect 1, the modular composite structure includes a third molded composite core structure, the third molded composite core structure being attached to the second molded composite core structure such that the second molded composite core structure separates the first and the third molded composite structures.

[0011] In another example of aspect 1, the first modular composite is a lower structure part for a vehicle.

[0012] In another example of aspect 1, the first molded composite core structure is a floor pan section and the second molded composite core structure is a U-shaped utility tunnel for a vehicle.

[0013] In another example of aspect 1, the third molded composite core structure is a floor pan section.

[0014] In another example of aspect 1, the first molded composite core structure is segmented in that the first molded composite core contains a first core section and a second core section.

[0015] In another example of aspect 1, the first molded composite core structure is a ribbed core, wherein the ribbed core has a free second surface not in contact with a fiber layer, for example, the free second surface is directly opposed to the first surface that is bonded to the first fiber layer.

[0016] In another example of aspect 1, the ribbed core includes a molded thermoplastic resin, wherein the thermoplastic material resin is a long fiber reinforced thermoplastic having fibers that can range from 5 mm to 100 mm or more.

[0017] In a second aspect, there is a modular composite lower structure for a vehicle that includes a first molded composite floor pan segment having a first core that has a first surface and a central area of increased thickness along its length, the first surface of the first core being bonded to a first fiber layer embedded in a first polymer, and a first fiber reinforcement region embedded in the first polymer, the first fiber reinforcement region overlies a portion of the central area of increased thickness of the first core. The modular composite lower structure further includes a U-shaped utility structure that includes a second core having a first surface, a first fiber substrate, the first fiber substrate containing fibers embedded in a second polymer, the first fiber substrate being bonded to the first surface of the second core, and the first fiber substrate having a horizontal center portion and two substantially vertical portions on each side of the horizontal center portion; and a second fiber reinforcement region bonded to and overlying the horizontal center portion of the first fiber substrate, wherein the first molded composite floor pan structure is attached to the U-shaped utility structure.

[0018] In an example of aspect 2, the second fiber reinforcement region extends to overlie a portion of the two substantially vertical portions of the first fiber substrate.

[0019] In another example of aspect 2, the U-shaped utility structure has a first end and a second end, the first end of the U-shaped utility structure being attached to the first molded composite floor pan structure.

[0020] In another example of aspect 2, the second end of the U-shaped utility structure is attached to a second molded composite floor pan structure, wherein the U-shaped utility structure separates the first molded composite floor pan structure and the second molded composite floor pan structure.

[0021] In another example of aspect 2, the first core is segmented such that the first core includes a first core section and a second core section.

[0022] In another example of aspect 2, the first core is a ribbed core, wherein the ribbed core comprises a free second surface not bonded to another layer.

[0023] In another example of aspect 2, the ribbed core is made of a molded thermoplastic resin.

[0024] In another example of aspect 2, the central area of increased thickness of the first core has a horizontal surface portion and two substantially vertical surfaces on each side of the horizontal surface portion, the first fiber reinforcement region overlies the horizontal surface portion of the central area of increased thickness.

[0025] Any one of the above aspects (or examples of those aspects) may be provided alone or in combination with any one or more of the examples of that aspect discussed above; e.g., the first aspect may be provided alone or in combination with any one or more of the examples of the first aspect discussed above; and the second aspect may be provided alone or in combination with any one or more of the examples of the second aspect discussed above; and so forth.

[0026] Additional features and advantages will be set forth in the detailed description which follows, and in part will be readily apparent to those skilled in the art from that description or recognized by practicing the embodiments as described herein, including the detailed description which follows, the claims, as well as the appended drawings.

[0027] It is to be understood that both the foregoing general description and the following detailed description are merely exemplary, and are intended to provide an overview or framework to understanding the nature and character of the claims. The accompanying drawings are included to provide a further understanding and are incorporated in and constitute a part of this specification. The drawings illustrate one or more embodiments, and together with the description serve to explain principles and operation of the various embodiments. Directional terms as used herein—for example, up, down, right, left, front, back, top, bottom—are made only with reference to the figures as drawn and are not intended to imply absolute orientation.

BRIEF DESCRIPTION OF THE DRAWINGS

[0028] The above and other features, examples and advantages of aspects or examples of the present disclosure are better understood when the following detailed description is read with reference to the accompanying drawings, in which:

[0029] FIG. 1 shows a cross-section view of a modular structural composite of a vehicle floor pan with a transmission tunnel.

[0030] FIG. 2 shows a cross-section view of a modular structural composite of a vehicle floor pan with a transmission tunnel.

[0031] FIG. 3 shows a cross-section view of a structural composite of a vehicle floor pan.

[0032] FIG. 4 shows a cross-section view of a structural composite of a vehicle floor pan.

[0033] FIG. 5 shows a cross-section view of a modular structural composite of a vehicle floor pan with a transmission tunnel.

DETAILED DESCRIPTION

[0034] The terminology as set forth herein is for description of the embodiments only and should not be construed as limiting the invention as a whole.

[0035] Herein, when a range such as 5-25 (or 5 to 25) is given, this means preferably at least or more than 5 and, separately and independently, preferably not more than 25. In an example, such a range defines independently at least 5, and separately and independently, not more than 25.

[0036] The terms “substantial,” “substantially,” and variations thereof as used herein are intended to note that a described feature is equal or approximately equal to a value or description. For example, a “substantially planar” surface is intended to denote a surface that is planar or approximately planar. It also is noted that the terms “substantially” and “about” may be utilized herein to represent the inherent degree of uncertainty that may be attributed to any quantitative comparison, value, measurement, or other representation. These terms are also utilized herein to represent the degree by which a quantitative representation may vary from a stated reference without resulting in a change in the basic function of the subject matter at issue.

[0037] The present disclosure relates to modular composite structures that can be used as components or elements in a variety of structures or applications. For example, the modular composite structures can be used in automotive applications and can be a structural or frame component, a lower structure component, flooring component, body panel, or the like in a vehicle (e.g., passenger vehicle, car, truck, bus, tractor, all terrain vehicle, motorcycle). In some embodiments, the modular composite structures can be a floor pan or segment thereof or a utility throughput or tunnel or segment thereof. Floor pans can be part of a lower structure for a passenger vehicle and a utility tunnel can function to provide a housing for various vehicle parts, e.g., wiring, transmission parts, connectors, couplings, etc. The modular composite structures can be connected or attached to one another to form a multi-component modular structure in a vehicle, for example, a segmented floor pan and utility tunnel structure.

[0038] The modular composite structures can generally have increased stiffness that resists bending and torsion of the structures and are relatively lightweight. In one or more embodiments, the modular composite structures can further have an energy-absorbing component, for example, a crushable thermoplastic core. The energy-absorbing component is preferably strong enough to absorb energy and deflect it from being sent to a passenger or other structural components in the vehicle. The modular composite structures can also have one or more components that effectively attenuate noise, vibration or a combination thereof. Preferably, the modular composite structures are lightweight, stiff and include a component for absorbing energy and reducing

noise and/or vibration in the vehicle. Other advantages of the modular composite structures can include being easily formable into a desirable shape by conventional molding methods that preferably use low or moderate pressure and heat, which advantageously lowers time and cost to manufacture the structures.

[0039] The individual composite structures of the overall modular or multi-component composite structure can be identical or substantially similar to one another (e.g., a near mirror image of a structure to be attached to). In an example, a floor pan can be segmented into two or more sections, wherein each section is formed by a composite structure having similar materials and/or design as the other section or sections and can form an overall floor pan design when attached together. In one or more embodiments, a pair of individual composite structures can be different from one another. For example, a floor pan or section thereof can be attached to another component, such as a non-floor pan composite structure (e.g., a utility tunnel). In one or more embodiments, individual composite structures are attached to one another to form the final modular composite structure, which can include two or more composite structures or 2 to 10 composite structures. The individual composite structures can be attached to one another by conventional methods, for example, using an adhesive or epoxy, fastener (e.g., screw, bolt, clip) or welding.

[0040] The individual composite structures can have similar components that can be made of the same or similar materials. For example, the composite structures can have a fiber-containing layer at least partially adhered to a core structure having select reinforced areas or regions thereon. The reinforced areas provide increased stiffness to resist bending and torsion forces acting on the composite structure. In one or more embodiments, the reinforced regions can be positioned at a central area of the composite structure. The fiber layers and fiber reinforcement regions of various individual composite structures can be made of the same or similar materials to reduce material and manufacturing costs. Similarly, when recycled materials can be substituted, for example, for fibers in the fiber layers, such materials can be used to further reduce costs and promote sustainability.

[0041] One or more embodiments further include methods for fabricating and manufacturing individual and modular composite structures. For example, a fiber layer can be positioned or applied on a surface or multiple surfaces of a core material (e.g., a first surface) to form a blank. Reinforcement fibers can be applied at select areas onto the core material or applied fiber layer(s). Reinforcement fibers can be applied in a roving method onto the fiber layer and/or core material. A roving method can include a rotating table to move the composite structure to a desired fiber application area wherein the reinforcement fibers (e.g., in strips of unidirectional fiber) can be applied (e.g., with a mechanical applicator) to select areas of the structure. A curable material (e.g., resin) can be sprayed, poured, spread, rolled, brushed or calendared onto the fiber layer and reinforcement fibers to coat and embed the fibers in the curable material to form a pre-form composite. Under heated conditions, the pre-form composite can be molded (e.g., in a compression or press mold) to form the final shape of the composite structure.

[0042] In one embodiment, the manufacturing methods can be carried out in a series of robotic work cells or manufacturing stations. In a first cell, a blank or biscuit is formed by sandwiching a core material between two face

sheets (fiber layers) and an initial layer of thermoset resin is applied to the face sheets. The face sheets can contain fiber or be a fiberglass material. In a second cell, reinforcement material can be applied at one or more select areas onto the wetted face sheets. Reinforcement material can include unidirectional glass, aramid, carbon fiber or a combination thereof. In a third cell, additional thermoset resin is applied to the reinforcement material sections, or alternatively, to the entire face sheets. The reinforced pre-form composite is molded in a low-pressure, heated press using a steel or aluminum tool. In a fourth cell, the composite structure is trimmed to a final shape if needed and one or more fasteners are applied to edge areas for facilitating attachment to another composite structure to form a modular composite structure.

[0043] In another example method, a series of robotic cells are used to form a composite structure. In a first cell, a sheet of fabric is constructed, for example, a thermoplastic glass mat. For instance, sheet fabrics can be stitched together, which can be thermoplastic materials that can be locally welded. In a second cell, reinforcement material is selectively applied to areas on the sheet of fabric. Reinforcement material can include unidirectional glass, aramid, carbon fiber or a combination thereof. In a third cell, charges of a long fiber molding compound are applied in locations where core material is desired. The molding compound is applied in sufficient quantities for forming ribs of core material that can accommodate the addition of integral fasteners if desired. In a fourth cell, the pre-form composite is heated (e.g., rapid heating with IR energy) and then molded to a final shape in a heated, pressure mold. In a final step, trimming of the composite structure is completed if needed and one or more fasteners are added to facilitate attachment to another composite structure.

[0044] Turning to the figures, FIG. 1 shows a modular composite structure 40 that includes three individual composite structures 10, 20, 30 attached to one another. Structure 40 can be a component of a vehicle such that structure 40 is secured to other portions or parts of a vehicle, for example, a frame structure. As shown, composite structures 10 and 30 can be floor pan segments for a passenger vehicle. Structures 10, 30 have cores 12, 32 arranged between two fiber layers. The cores 12, 32 can extend in a central area of the composite along its entire length as shown.

[0045] In one or more embodiments, the cores (e.g., 12) of the individual composite structures can be a plurality of open or gas-filled cells defined by cell walls. The cells can have any suitable cross-section shape (e.g., circular, hexagon, square, etc.). For example, the core can be a honeycomb structure that includes many individual open cells side by side and arranged in the composite structures such that the cell walls are perpendicular to the longitudinal axis of the composite structure or an adjacent fiber layer. Alternatively, the cell walls can be arranged at other angles, for example, parallel or angled relative to the longitudinal axis of the composite structure. The cell walls can be made of plastic, for example, a thermoplastic or thermoset material. In one example, polypropylene or polycarbonate can be used as the material for the core and/or cell walls.

[0046] The core is preferably easily moldable to arrive at the desired shape for the composite structure. In one or more embodiments, the core can have regions of different thicknesses and angles along its length. As shown, cores 12, 32 have a generally uniform thickness along its length with

each end being pinched or crushed during molding to have a reduced thickness section. The floor pan cores **12**, **32** each have a central area of increased thickness that is about 1.5 to 3 times thicker than the thickness of the core material nearby on each side. The central area of increased thickness can be a raised hump or ridge that runs along the length of the core and has a substantially horizontal section as opposed to a sharp peak. The central area of increased thickness imparts stiffness to the core to resist bending and torsion forces that may be applied to a floor pan during operation and assembly.

[0047] FIG. 1 also shows a utility tunnel **20** composite structure. The core **22** material of the utility tunnel **20** has a substantially uniform thickness molded into a U-shape having horizontal end sections or lips for attachment to other composite structures. As shown, core **22** is partially crushed honeycomb cell material. The structure **20** has a horizontal or planar center section flanked on each side by substantially vertical sections that angle outward at about 5 to 20 degrees relative to the vertical axis of the structure **20**, which is also shown for structure **60** in FIG. 2. The utility tunnel **20** can alternatively have other core materials, for example, foam, thermoplastic structures, matrix or lattice.

[0048] As shown, the core material can be a uniform material of a single, continuous design. In one or more embodiments, the core can be a segmented or non-continuous core that includes one or more core sections. The individual core sections can be loosely packed together and sandwiched between fiber layers to maintain the desired core shape. In another example, the core sections can be attached to one another by a conventional method, such as glue, adhesive, tape, mechanical fasteners (e.g., rivets) and the like. Core sections can be made of different materials and have different designs depending on the desired properties. For instance, core sections near areas of high vibration or sound can include vibration and sound dampening material (e.g., foam). Core sections near areas of significant geometric change or non-uniform shape can contain a crushable material that can be easily molded to conform to the contours of the composite structure shape, for example, at a bend or pinched area in the composite structure. The segmented arrangement of core sections can isolate energy imparted onto the composite structure to one area and prevent or reduce the ability of the energy to dissipate to other parts of the core or nearby vehicle parts or passengers therein.

[0049] The core material can have properties that provide an energy absorbing ability. For example, the core can be a low density, crushable core that deforms upon impact and yet retains mechanical integrity (e.g., stiffness) in normal operation. The open cells and cell walls of a honeycomb core can absorb impact energy as the cell walls collapse and break. Other materials that can absorb energy can include elastomers, foams (e.g., open cell, viscoelastic, etc.), paper (e.g., cardboard), or molded resins. These materials can be combined with the plurality of cells, for example, the cells or a portion thereof (e.g., select regions where vibration and/or noise attenuation or increased rigidity is desired) can be filled or partially filled with foams or elastomers. In other embodiments, the core material can reduce acoustic and structural vibration as compared to other conventional materials such as steel. In one or more embodiments, the core materials of the composite structures of the present disclosure can include a conducting fiber (e.g., electrical conduct-

ing) and/or a sensor, for example, for transmission of power or monitoring properties or behavior of the composite structure.

[0050] As shown in FIG. 1, a core **12** can be sandwiched between and in direct contact with fiber layers **13**, **14**. The fiber layers **13**, **14** can contain continuous and/or discontinuous fibers embedded in a polymer material to form layers having a substantially uniform thickness. The fibers can be arranged together to form a sheet or mat that can be positioned on a core material. The fibers can be entangled in a random pattern or in a more systematic design, for example, the fibers can be weaved together in the form of a woven fiber sheet. In other examples, the fibers can be loosely bundled together or pressed together into a mat to form a fiber sheet. A whole fiber sheet can be used to cover a core material surface (e.g., a top surface). Alternatively, strips or sections of fibers can be applied side by side in a segmented arrangement to cover a core material surface. Examples of fibers that can be used in the fiber layer include carbon fibers, glass fibers, plastic fibers, etc. In one example, an inexpensive fiberglass sheet can be applied to a first surface of a core material.

[0051] The fibers can be applied to the surface of a core material to cover an entire face surface of the core material or a portion thereof. Once the fibers are arranged on a core material, a polymer forming material or resin can be applied onto the fibers. The polymer forming material can penetrate and soak into the fibers arranged on the core material. As described herein, polymer forming material can be pushed and forced into the fiber layer to embed the fibers during a molding step, for example, a press or compression mold can push polymeric resin into the fibers to coat the fibers, fill voids in the fiber layer and contact the core material. A sufficient amount of polymer forming material can be applied to the fibers to form polymer layer that embeds the fibers and contacts the core material to adhere the fibers to one another and to the core. In one or more embodiments, the polymer can be formed from a curable polymer resin or composition. The composition can include a mixture of components, for example, a thermoset material, a thermoplastic material, a hardener, a catalyst, fillers, and any combination thereof. Materials can include epoxy, polyurethane, polyether ether ketone, polyethylene, or combinations thereof. The composition preferably has a low cure period in the range of 1 to 20 minutes, or less than 15, 10 or 5 minutes. The polymer forming material once cured can bond the fiber layer to the core material to form a laminate as the composite structure. The fiber layer preferably bonds or adheres to the core to prevent delamination or separation of the fiber layer from the core during use.

[0052] As shown in FIG. 1, the fiber layers **13**, **14** cover all or a significant portion of the top and bottom surface faces of the core **12** of composite structure **10**. Likewise, composite structure **30** has a similar arrangement in that fiber layers **33**, **34** directly cover the top and bottom surface faces of core **32**. In both composites **10**, **30**, the two end faces of the cores **12**, **32** are exposed. In an alternative arrangement, the fiber layers can extend past the ends of the top and bottom surfaces of the cores to overlap each core end to encase the core material. The utility tunnel structure **20** also contains a top and bottom fiber layer **23**, **24** that respectively cover and are in direct contact with the top and bottom surfaces of core **22**.

[0053] The composite structures of FIG. 1 each have a single fiber reinforcement region that overlies select surface portions of the cores. In composite structure 10, a fiber reinforcement region 16 is arranged over the central area of increased thickness of core 12. The fiber reinforcement region 16 entirely covers the substantially horizontal section of the central area and further extends over the substantially vertical sections on each side. In a similar arrangement, fiber reinforcement region 36 covers the substantially horizontal section of the central area of core 32, along with portions of the substantially vertical sections on each side. The utility tunnel structure 20 has a fiber reinforcement region 26 positioned at the center of the structure 20 and covering the horizontal center section of the U-shape. The fiber reinforcement region 26 extends slightly past the horizontal section of the utility tunnel to overlie the bend area that begins the transition to the substantially vertical sections on each side.

[0054] The fiber reinforcement regions provide additional strength and increased stiffness to select areas of the composite structures to resist bending and torsion forces. As shown in FIG. 1, the fiber reinforcement regions are positioned on the central areas of each composite and, in particular, the substantially horizontal sections of the central areas. Selectively positioning the fiber reinforcement regions along the horizontal center sections provides increase stiffness at the central mass of the composite, which in the case of composites 10, 30 is the area of the maximum core thickness. The reinforcement fiber regions can be positioned directly on the core material or directly on the fiber layer that overlies the core material. Composites 10, 30 have the fiber reinforcement regions 16, 36 directly in contact with the top surface of the cores 12, 32, whereas composite structure 20 has a single fiber reinforcement region positioned directly on top of fiber layer 23 that overlies core 22.

[0055] The fiber reinforcement regions can be applied in the above described method for the fibers in the fiber layers. In one example, the fiber reinforcement can be in the form of a patch, tape, strip or lane that is applied to the core or fiber layer. The fiber reinforcement regions can be symmetric or non-symmetrical (i.e. asymmetric) across the surface of the core material or fiber layer. For instance, the fiber reinforcement region may have sections of different widths or thicknesses across its surface. In one or more embodiments, the central areas or ridges of increased thickness of the composite structures can be a non-straight region that angles or curves along the length or width of a composite structure. To follow the central area (e.g. raised to topmost point) or ridges of increased thickness, the fiber reinforcement regions can be non-symmetrical in shape that can conform to the contours of the areas to be reinforced.

[0056] The fiber reinforcement regions (e.g., 26, 36) can be made of carbon fibers, glass fibers, aramid fibers and the like or combinations thereof. The fibers can have any suitable length and can be supplied in bundles of unidirectional fibers. The length of the fibers can be substantially equal to one another or vary such that the lengths are random throughout the reinforcement region. The length of the fibers is preferably greater than 50 mm to impart increased stiffness to select areas of the composites. The reinforcement fibers can be arranged in a variety of ways, for example, in a unidirectional/aligned or woven (e.g., basket weave) pattern. Multiple layers of unidirectional fibers can be used, for example, each layer of unidirectional fibers can be arranged

at a parallel, angled or perpendicular position relative to an underlying fiber reinforcement layer. Alternatively, the fibers can be discontinuous (e.g., fibers of different lengths) and appear as a random or non-uniform pattern.

[0057] The fiber reinforcement regions can be positioned on a fiber layer or core material in a variety of ways. In one or more embodiments, unidirectional fibers can be applied onto a substantially horizontal central area (e.g., an area of increased thickness) of a composite structure such that the unidirectional fibers are laid perpendicular to the length of the central area or ridge. In other embodiments, the fibers can be applied to lay parallel or angled (e.g., a 45 degree angle) to the length of a substantially horizontal central area. In other embodiments, randomly oriented discontinuous fibers can be applied in any direction to reinforce select areas of the composite structures.

[0058] As applied to a fiber layer or core material, a curable material can be applied onto the fiber reinforcement region or regions. The curable material can be the same curable material used to embed the fibers of the fiber layers, for example, fiber layers 13, 14. For instance, materials can include a mixture of components, for example, a thermoset material, a thermoplastic material, a hardener, a catalyst, fillers, and any combination thereof. Curable materials can include epoxy, polyurethane, polyether ether ketone, polyethylene, or combinations thereof. The curable material (e.g., resin) can be sprayed, poured, spread, rolled, brushed or calendared onto the fiber reinforcement region to embed or the fibers in the curable material to form a pre-form composite. Under heated conditions, the pre-form composite can be molded (e.g., in a compression) mold to form the final shape of the composite structure.

[0059] As formed, the composite structures can be attached or joined together to form a modular composite structure. As shown in FIG. 1, composite structures 10, 30 are adhered to each end of composite structure 20 with an adhesive 2. Any suitable adhesive can be used, for example, an epoxy. The adhesive is applied to an outer surface of a composite structure, for example, an exposed surface of fiber layer 24 or 13. It is preferable that the composite structures are permanently attached to one another to ensure structural integrity of the modular composite structure during use. Although not shown, other fasteners can be used in place of an adhesive, for example, a screw, snap fitting, rivet, clamp, bolt or clip.

[0060] A second modular composite structure 80 is shown in FIG. 2. The modular composite structure 80 contains three composite structures 50, 60, 70 attached to one another. Composite structures 50 and 70 are floor pan segments and composite structure 60, which separates the floor pan segments, is a U-shaped utility tunnel, for example, that can be used to house a transmission component.

[0061] Composite structure 50 has a ribbed core 52 with a top surface covered and in direct contact with fiber layer 53. Fiber layer 53 extends past one end of ribbed core 52 and forms an attachment section for joining composite structure 50 to another composite structure (e.g., structure 60). The bottom surface 52a of ribbed core 52 is exposed and not covered by other materials. Ribbed core 52 has a humped central area with an increased thickness. The central area has a substantially horizontal section flanked by two angled side faces. A fiber reinforcement region 56 overlies fiber layer 53 and covers the substantially horizontal area of the central area of increased thickness of ribbed core 52. The fiber

reinforcement region **56** extends slightly past the horizontal section of the central area to overlie the bend area that begins the transition to the angled sections on each side. Fiber layer **53** and fiber reinforcement region **56** can be embedded in a polymer forming composition as discussed above for the fiber layers and fiber reinforcement regions shown in FIG. 1.

[0062] Composite structure **60** of FIG. 2 has a single fiber layer **63** that forms the entire U-shape of the utility tunnel structure. Fiber layer **63** has a substantially horizontal section at its center, which is positioned between two substantially vertical sections that each end with a horizontal lip for attaching the utility tunnel to one or more other composite structures (e.g., **50**, **70**). The bottom surface of the substantially horizontal center section of fiber layer **63** is bonded to or adhered to ribbed core **62**, which spans across the entire bottom surface of the substantially horizontal section and into the bend areas of fiber layer **63** that transition into the substantially vertical sections. The ribbed core **62** has a bottom surface that is not covered by a material and is exposed to the open utility area of structure **60**.

[0063] Composite structure **60** further has three fiber reinforcement regions **66**, **67** and **68**. The fiber reinforcement regions can be made up of fibers and materials, as well as arrangement thereof, as discussed above for the composite structures of FIG. 1. As shown, fiber reinforcement region **66** covers and directly contacts the substantially horizontal section of fiber layer **63** of utility tunnel **60**, and along with a portion of the bend areas of fiber layer **63** that transition into the vertical sections on each side. Fiber reinforcement regions **67** and **68** are positioned directly on fiber layer **63** at the bend areas at the bottom of the substantially vertical sections and the start of the two horizontal lip sections. On one side of structure **60**, near both sides or ends of fiber reinforcement region **67**, one end of fiber layer **53** is attached with an adhesive **81** to the substantially vertical section of fiber layer **63**. At the one end of fiber layer **63**, an adhesive **81** secures composite structure **60** to a bottom surface of fiber layer **53** near the end of ribbed core **52**. Likewise, on the opposite end of structure **60**, near both sides or ends of fiber reinforcement region **68**, one end of fiber layer **73** is attached with an adhesive **81** to a substantially vertical section of fiber layer **63**. An additional adhesive **81** secures an end of fiber layer **63** to a bottom surface of fiber layer **73** near an end of ribbed core **72**. The attachment of the three composite structures forms the modular composite structure **80**.

[0064] Composite structure **70** has a ribbed core **72** with an exposed bottom surface **72a** not covered by other materials and a top surface (e.g., a first surface) entirely covered by and in direct contact with fiber layer **73** along its entire length. Ribbed core **72** has a humped central area with an increased thickness. The central area has a substantially horizontal section flanked by two angled side faces. A fiber reinforcement region **76** overlies fiber layer **73** and covers the substantially horizontal area of the central area of increased thickness of ribbed core **72**. The fiber reinforcement region **76** extends slightly past the horizontal section of the central area to overlie the bend area that begins the transition to the angled sections on each side. At one end, fiber layer **73** extends past the end of ribbed core **72** and forms an attachment section (e.g., use of adhesive **81**) for securing the structure **70** to another composite structure. As noted above, fiber layer **73** and fiber reinforcement region **76**

can be embedded in a polymer forming composition as discussed above for the fiber layers and fiber reinforcement regions shown in FIG. 1.

[0065] The ribbed cores of modular structure composite **80** can be made from thermoplastic material that can be molded into a desired shape. Preferably, the ribbed core achieves an equivalent stiffness with less expensive materials as compared to conventional composite laminate constructions. The thermoplastic material or resin used for the ribbed cores can be molded at low or moderate pressure under heat. For example, thermoplastic material in the form of long fibers (e.g., loosely tangled fiber material) can be applied to a fiber mat (e.g., a fiberglass mat or glass mat thermoplastic) that forms the fiber layer of the composite. The long fibers of thermoplastic material can be molded into a desired core shape in a press along with curing of the fiber layer and bonding to the formed core shape. In addition to a ribbed design, the core material can be molded into other shapes as desired, for example, lattice or coffered array of open shapes (e.g., rectangular or square). As part of the molding step, not shown, one or more fasteners can be integrated into the core or fiber layer to facilitate attachment of the structure to other composite structures.

[0066] While various aspects and embodiments of the compositions and methods have been disclosed herein, other aspects and embodiments will be apparent to those skilled in the art. The various aspects and embodiments disclosed herein are for purposes of illustration and are not intended to be limiting, with the true scope and spirit being indicated by the claims.

What is claimed is:

1. A modular composite structure for a lower structure part of a vehicle, the modular composite structure comprising:
 - a. a first molded composite core structure comprising:
 - i. a first core comprising a first surface, a first fiber layer embedded in a first polymer, the first fiber layer overlying the first surface of the first core;
 - ii. a first fiber reinforcement region overlying a portion of the first surface of the first core;
 - b. a second molded composite core structure attached to the first molded composite core structure to form a lower structure part of a vehicle, the second molded composite core structure comprising:
 - i. a first fiber substrate, the first fiber substrate comprising fibers embedded in a second polymer, the first fiber substrate overlying a first surface of a second core;
 - ii. a second fiber reinforcement region overlying a portion of the second core.
2. The modular composite structure of claim 1, wherein the first molded composite core structure comprises a central area of increased thickness along its length, and the first fiber reinforcement region overlies a portion of the central area of increased thickness of the first molded composite core structure.
3. The modular composite structure of claim 2, wherein the central area of increased thickness is formed with at least one additional core overlying the first core of the first molded composite core structure.
4. The modular composite structure of claim 1, wherein the first molded composite core structure comprises a central area of increased thickness along its length, the central area

of increased thickness is about 1.5 to 3 times thicker than a section of the first core adjacent each side of the central area of increased thickness.

5. The modular composite structure of claim **1**, wherein the first core of the first molded composite core structure comprises at least one of a honeycomb material, a solid thermoplastic material or a foam.

6. The modular composite structure of claim **1**, wherein the first core of the first molded composite core structure is an energy-absorbing component that is crushable and deforms upon impact.

7. The modular composite structure of claim **1**, wherein the first core of the first molded composite core structure is a honeycomb core comprising a plurality of cells defined by cell walls, the cell walls comprising a thermoplastic material or thermoset material.

8. The modular composite structure of claim **1**, wherein the first core of the first molded composite core structure has two ends, and each end of the first core has a reduced thickness section.

9. The modular composite structure of claim **1**, wherein the first core has a second surface, the second surface of the first core being in contact with a second fiber layer such that the first core is sandwiched between the first fiber layer and the second fiber layer.

10. The modular composite structure of claim **9**, wherein the first fiber layer and the second fiber layer extend past the first core and contact one another.

11. The modular composite structure of claim **1**, wherein the first fiber layer comprises fibers selected from the group consisting of carbon fibers, glass fibers, aramid fibers, plastic fibers, and a combination thereof.

12. The modular composite structure of claim **1**, wherein the first fiber layer comprises fibers, the fibers being in a random pattern.

13. The modular composite structure of claim **1**, wherein the first fiber layer comprises fibers, the fibers being in a woven pattern.

14. The modular composite structure of claim **1**, wherein the first polymer being formed from a curable composition, the curable composition comprising a thermoset material, a thermoplastic material, and a combination thereof.

15. The modular composite structure of claim **1**, wherein the first fiber reinforcement region comprises unidirectional fibers.

16. The modular composite structure of claim **1**, wherein the first fiber reinforcement region comprises multiple layers of unidirectional fibers.

17. The modular composite structure of claim **1**, wherein the first fiber reinforcement region comprises selected from the group consisting of carbon fibers, glass fibers, aramid fibers, plastic fibers, and a combination thereof.

18. The modular composite structure of claim **1**, wherein the second molded composite core structure being attached to the first molded composite core structure by at least one of an adhesive, an epoxy, a fastener and a weld.

19. The modular composite structure of claim **1**, wherein the first molded composite core structure is a vehicle floor pan section.

20. The modular composite structure of claim **1**, wherein the second molded composite core structure is a U-shaped utility tunnel.

* * * * *