

(12) **United States Patent**
De Villiers et al.

(10) **Patent No.:** **US 10,219,911 B2**
(45) **Date of Patent:** **Mar. 5, 2019**

- (54) **PROSTHETIC DISC FOR INTERVERTEBRAL INSERTION**
- (71) Applicant: **Simplify Medical Pty Ltd.**, Paddington NSW (AU)
- (72) Inventors: **Malan De Villiers**, Wapadrand (ZA); **Ulrich Hahnle**, Johannesburg (ZA)
- (73) Assignee: **Simplify Medical Pty Ltd** (AU)
- (*) Notice: Subject to any disclaimer, the term of this patent is extended or adjusted under 35 U.S.C. 154(b) by 0 days.

(21) Appl. No.: **15/916,139**

(22) Filed: **Mar. 8, 2018**

(65) **Prior Publication Data**
US 2018/0193159 A1 Jul. 12, 2018

Related U.S. Application Data

(63) Continuation of application No. 14/612,431, filed on Feb. 3, 2015, now Pat. No. 10,052,211, which is a (Continued)

(51) **Int. Cl.**
A61F 2/44 (2006.01)
A61F 2/50 (2006.01)
A61F 2/30 (2006.01)

(52) **U.S. Cl.**
CPC **A61F 2/442** (2013.01); **A61F 2/4425** (2013.01); **A61F 2002/3008** (2013.01); **A61F 2002/30131** (2013.01); **A61F 2002/30245** (2013.01); **A61F 2002/30299** (2013.01); **A61F 2002/30518** (2013.01); **A61F 2002/30649** (2013.01); **A61F 2002/30785** (2013.01); **A61F 2002/30822** (2013.01); **A61F 2002/30838** (2013.01); **A61F 2002/30884** (2013.01); **A61F 2002/30904** (2013.01); **A61F 2002/443** (2013.01);

(Continued)

(58) **Field of Classification Search**
CPC A61F 2/44; A61F 2/4405; A61F 2/4425; A61F 2/443
USPC 623/17.11, 17.14-17.16
See application file for complete search history.

(56) **References Cited**

U.S. PATENT DOCUMENTS

3,486,505 A 12/1969 Gordon
3,867,728 A 2/1975 Stubstad et al.
(Continued)

FOREIGN PATENT DOCUMENTS

DE 3023353 A1 4/1981
DE 10035182 A1 2/2002
(Continued)

OTHER PUBLICATIONS

Notice of allowance dated Nov. 21, 2014 for U.S. Appl. No. 14/150,437.
(Continued)

Primary Examiner — Anu Ramana
(74) *Attorney, Agent, or Firm* — Wilson Sonsini Goodrich & Rosati

(57) **ABSTRACT**

A prosthetic disc for insertion between adjacent vertebrae includes a core having upper and lower curved surfaces, upper and lower plates, and peripheral restraining structure on at least one of the upper plate, the lower plate and the core. Each plate has an outer surface which engages a vertebra and an inner curved surface which slides over the curved surface of the core. The peripheral restraining structure serves to hold the core against a curved surface of at least one of the plates during sliding movement of the plates over the core.

14 Claims, 3 Drawing Sheets

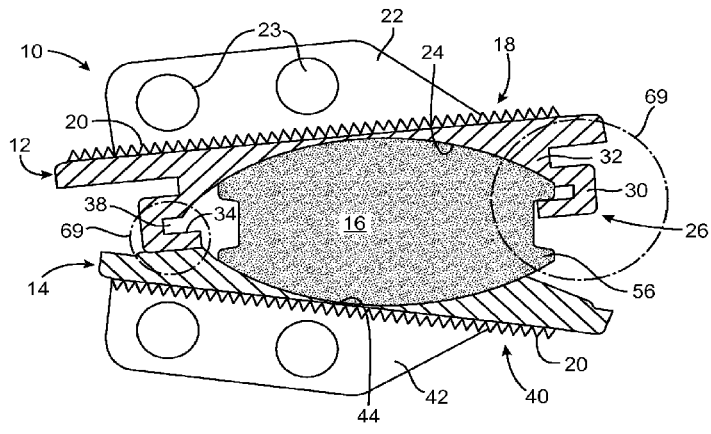

Related U.S. Application Data

continuation of application No. 14/150,437, filed on Jan. 8, 2014, now Pat. No. 8,974,533, which is a continuation of application No. 12/626,027, filed on Nov. 25, 2009, now Pat. No. 8,845,729, which is a continuation of application No. 10/855,253, filed on May 26, 2004, now Pat. No. 7,753,956.

(60) Provisional application No. 60/473,802, filed on May 27, 2003, provisional application No. 60/473,803, filed on May 27, 2003.

(52) **U.S. Cl.**

CPC A61F 2002/5098 (2013.01); A61F 2230/0076 (2013.01); A61F 2310/00179 (2013.01)

(56) **References Cited**

U.S. PATENT DOCUMENTS

4,309,777 A 1/1982 Patil
 4,531,917 A 7/1985 Linkow et al.
 4,566,466 A 1/1986 Ripple et al.
 4,619,660 A 10/1986 Christiansen et al.
 4,673,407 A 6/1987 Martin
 4,759,766 A 7/1988 Buettner-Janzen et al.
 4,759,769 A 7/1988 Hedman et al.
 4,834,757 A 5/1989 Brantigan
 4,863,477 A 9/1989 Monson
 4,904,261 A 2/1990 Dove et al.
 4,917,704 A 4/1990 Frey et al.
 4,932,969 A 6/1990 Frey et al.
 4,946,378 A 8/1990 Hirayama et al.
 4,997,432 A 3/1991 Keller
 5,035,716 A 7/1991 Downey
 5,057,108 A 10/1991 Shetty et al.
 5,071,437 A 12/1991 Steffee
 5,122,130 A 6/1992 Keller
 5,195,526 A 3/1993 Michelson
 5,258,031 A 11/1993 Salib et al.
 5,282,861 A 2/1994 Kaplan
 5,314,477 A 5/1994 Marnay
 5,320,644 A 6/1994 Baumgartner
 5,370,697 A 12/1994 Baumgartner
 5,394,457 A 2/1995 Leibinger et al.
 5,401,269 A 3/1995 Buettner-Janzen et al.
 5,415,704 A 5/1995 Davidson
 5,458,642 A 10/1995 Beer et al.
 5,462,575 A 10/1995 Del Corso
 5,484,437 A 1/1996 Michelson
 5,489,307 A 2/1996 Kuslich et al.
 5,505,732 A 4/1996 Michelson
 5,507,816 A 4/1996 Bullivant
 5,534,030 A 7/1996 Navarro et al.
 5,556,431 A 9/1996 Buettner-Janzen
 5,562,738 A 10/1996 Boyd et al.
 5,674,296 A 10/1997 Bryan et al.
 5,676,701 A 10/1997 Yuan et al.
 5,676,702 A 10/1997 Ratron
 5,683,465 A 11/1997 Shinn et al.
 5,702,450 A 12/1997 Bisserie
 5,709,683 A 1/1998 Bagby
 5,728,159 A 3/1998 Stroeve et al.
 5,741,253 A 4/1998 Michelson
 5,776,198 A 7/1998 Rabbe et al.
 5,782,832 A 7/1998 Larsen et al.
 5,797,909 A 8/1998 Michelson
 5,824,094 A 10/1998 Serhan et al.
 5,836,948 A 11/1998 Zucherman et al.
 5,865,846 A 2/1999 Bryan et al.
 5,865,848 A 2/1999 Baker
 5,888,226 A 3/1999 Rogozinski
 5,895,428 A 4/1999 Berry
 5,899,901 A 5/1999 Middleton

5,899,911 A 5/1999 Carter
 5,928,284 A 7/1999 Mehdizadeh
 5,989,251 A 11/1999 Nichols
 5,989,291 A 11/1999 Ralph et al.
 6,001,130 A 12/1999 Bryan et al.
 6,019,792 A 2/2000 Cauthen
 6,022,376 A 2/2000 Assell et al.
 6,039,761 A 3/2000 Li et al.
 6,039,763 A 3/2000 Shelokov
 6,080,155 A 6/2000 Michelson
 6,083,228 A 7/2000 Michelson
 6,086,613 A 7/2000 Camino et al.
 6,096,038 A 8/2000 Michelson
 6,132,465 A 10/2000 Ray et al.
 6,136,031 A 10/2000 Middleton
 6,139,551 A 10/2000 Michelson et al.
 6,139,579 A 10/2000 Steffee et al.
 6,143,033 A 11/2000 Paul et al.
 6,146,421 A 11/2000 Gordon et al.
 6,156,067 A 12/2000 Bryan et al.
 6,159,214 A 12/2000 Michelson
 6,162,252 A 12/2000 Kuras et al.
 6,174,311 B1 1/2001 Branch et al.
 6,176,881 B1 1/2001 Schaer et al.
 6,193,757 B1 2/2001 Foley et al.
 6,224,595 B1 5/2001 Michelson
 6,224,607 B1 5/2001 Michelson
 6,231,609 B1 5/2001 Mehdizadeh
 6,235,030 B1 5/2001 Zucherman et al.
 6,261,296 B1 7/2001 Aebi et al.
 6,264,695 B1 7/2001 Stoy
 6,290,726 B1 9/2001 Pope et al.
 6,296,664 B1 10/2001 Middleton
 6,315,797 B1 11/2001 Middleton
 6,322,567 B1 11/2001 Mittelstadt et al.
 6,336,941 B1 1/2002 Subba et al.
 6,348,071 B1 2/2002 Steffee et al.
 6,368,350 B1 4/2002 Erickson et al.
 6,368,351 B1 4/2002 Glenn et al.
 6,375,681 B1 4/2002 Truscott
 6,375,682 B1 4/2002 Fleischmann et al.
 6,395,032 B1 5/2002 Gauchet
 6,402,785 B1 6/2002 Zdeblick et al.
 6,409,766 B1 6/2002 Brett
 6,413,278 B1 7/2002 Marchosky
 6,416,551 B1 7/2002 Keller
 6,436,098 B1 8/2002 Michelson
 6,440,139 B2 8/2002 Michelson
 6,447,544 B1 9/2002 Michelson
 6,478,800 B1 11/2002 Fraser et al.
 6,517,544 B1 2/2003 Michelson
 6,517,580 B1 2/2003 Ramadan et al.
 6,520,967 B1 2/2003 Cauthen
 6,520,996 B1 2/2003 Manasas et al.
 6,527,804 B1 3/2003 Gauchet et al.
 6,533,817 B1 3/2003 Norton et al.
 6,537,279 B1 3/2003 Michelson
 6,554,863 B2 4/2003 Paul et al.
 6,562,047 B2 5/2003 Ralph et al.
 6,562,074 B2 5/2003 Gerbec et al.
 6,565,574 B2 5/2003 Michelson
 6,579,320 B1 6/2003 Gauchet et al.
 6,582,466 B1 6/2003 Gauchet
 6,582,468 B1 6/2003 Gauchet
 6,592,624 B1 7/2003 Fraser et al.
 6,599,294 B2 7/2003 Fuss et al.
 6,607,558 B2 8/2003 Kuras
 6,607,559 B2 8/2003 Ralph et al.
 6,610,092 B2 8/2003 Ralph et al.
 6,623,525 B2 9/2003 Ralph et al.
 6,645,248 B2 11/2003 Casutt
 6,648,895 B2 11/2003 Burkus et al.
 6,652,533 B2 11/2003 O'Neil
 6,660,038 B2 12/2003 Boyer et al.
 6,666,866 B2 12/2003 Martz et al.
 6,669,731 B2 12/2003 Ralph et al.
 6,669,732 B2 12/2003 Serhan et al.
 6,673,113 B2 1/2004 Ralph et al.
 6,682,562 B2 1/2004 Viart et al.

(56)

References Cited

U.S. PATENT DOCUMENTS

6,689,132 B2	2/2004	Biscup	7,682,396 B2	3/2010	Beaurain et al.
6,706,068 B2	3/2004	Ferree	7,753,956 B2	7/2010	De Villiers et al.
6,709,439 B2	3/2004	Rogers et al.	7,862,614 B2	1/2011	Keller et al.
6,712,819 B2	3/2004	Zucherman et al.	8,062,371 B2	11/2011	De Villiers et al.
6,712,825 B2	3/2004	Aebi et al.	8,444,695 B2	5/2013	De Villiers et al.
6,723,097 B2	4/2004	Fraser et al.	8,454,698 B2	6/2013	De Villiers et al.
6,726,720 B2	4/2004	Ross et al.	8,845,729 B2	9/2014	De Villiers et al.
6,726,721 B2	4/2004	Stoy et al.	8,974,533 B2	3/2015	De Villiers et al.
6,733,532 B1	5/2004	Gauchet et al.	9,655,741 B2	5/2017	De Villiers et al.
6,740,118 B2	5/2004	Eisermann et al.	9,788,965 B2	10/2017	De Villiers et al.
6,740,119 B2	5/2004	Ralph et al.	2001/0016773 A1	8/2001	Serhan et al.
6,755,841 B2	6/2004	Fraser et al.	2001/0029377 A1	10/2001	Aebi et al.
6,764,512 B2	7/2004	Keller	2001/0056302 A1	12/2001	Boyer et al.
6,764,515 B2	7/2004	Ralph et al.	2002/0022845 A1	2/2002	Zdeblick et al.
6,770,095 B2	8/2004	Grinberg et al.	2002/0035400 A1	3/2002	Bryan et al.
6,790,233 B2	9/2004	Brodke et al.	2002/0045904 A1	4/2002	Fuss et al.
6,793,678 B2	9/2004	Hawkins	2002/0068936 A1	6/2002	Burkus et al.
6,814,737 B2	11/2004	Cauthen	2002/0091392 A1	7/2002	Michelson
6,821,298 B1	11/2004	Jackson	2002/0116009 A1	8/2002	Fraser et al.
6,827,740 B1	12/2004	Michelson	2002/0123753 A1	9/2002	Michelson
6,830,570 B1	12/2004	Frey et al.	2002/0128715 A1	9/2002	Bryan et al.
6,846,328 B2	1/2005	Cauthen	2002/0165550 A1	11/2002	Frey et al.
6,863,673 B2	3/2005	Gerbec et al.	2002/0177897 A1	11/2002	Michelson
6,875,213 B2	4/2005	Michelson	2002/0198532 A1	12/2002	Michelson
6,896,680 B2	5/2005	Michelson	2003/0009224 A1	1/2003	Kuras
6,899,735 B2	5/2005	Coates et al.	2003/0023245 A1	1/2003	Ralph et al.
6,936,071 B1	8/2005	Marnay et al.	2003/0028249 A1	2/2003	Baccelli et al.
6,936,132 B2	8/2005	Topolnitsky	2003/0040746 A1	2/2003	Mitchell et al.
6,964,686 B2	11/2005	Gordon	2003/0045884 A1	3/2003	Robie et al.
6,966,929 B2	11/2005	Mitchell	2003/0045939 A1	3/2003	Casutt
6,989,011 B2	1/2006	Paul et al.	2003/0074076 A1	4/2003	Ferree et al.
6,994,727 B2	2/2006	Khandkar et al.	2003/0083747 A1	5/2003	Winterbottom et al.
7,001,432 B2	2/2006	Keller et al.	2003/0100951 A1	5/2003	Serhan et al.
7,011,684 B2	3/2006	Eckman	2003/0125739 A1	7/2003	Bagga et al.
7,022,138 B2	4/2006	Mashburn	2003/0130662 A1	7/2003	Michelson
7,025,787 B2	4/2006	Bryan et al.	2003/0135277 A1	7/2003	Bryan et al.
7,044,983 B1	5/2006	Cheng	2003/0139812 A1	7/2003	Garcia et al.
7,056,344 B2	6/2006	Huppert et al.	2003/0187448 A1	10/2003	Michelson
7,060,073 B2	6/2006	Frey et al.	2003/0191536 A1	10/2003	Ferree
7,066,958 B2	6/2006	Ferree	2003/0195517 A1	10/2003	Michelson
7,081,120 B2	7/2006	Li et al.	2003/0195631 A1	10/2003	Ferree
7,083,651 B2	8/2006	Diaz et al.	2003/0199982 A1	10/2003	Bryan
7,087,055 B2	8/2006	Lim et al.	2003/0204261 A1	10/2003	Eisermann et al.
7,097,648 B1	8/2006	Globerman et al.	2003/0208271 A1	11/2003	Kuras
7,115,132 B2	10/2006	Errico et al.	2003/0229358 A1	12/2003	Errico et al.
7,118,580 B1	10/2006	Beyersdorff et al.	2003/0233145 A1	12/2003	Landry et al.
7,147,665 B1	12/2006	Bryan et al.	2003/0233155 A1	12/2003	Slemmer et al.
7,153,325 B2	12/2006	Kim et al.	2004/0002761 A1	1/2004	Rogers et al.
7,179,294 B2	2/2007	Eisermann et al.	2004/0024407 A1	2/2004	Ralph et al.
7,182,784 B2	2/2007	Evans et al.	2004/0024410 A1	2/2004	Olson et al.
7,198,644 B2	4/2007	Schultz et al.	2004/0030391 A1	2/2004	Ferree
7,207,991 B2	4/2007	Michelson	2004/0034426 A1	2/2004	Errico et al.
7,214,244 B2	5/2007	Zubok et al.	2004/0054411 A1	3/2004	Kelly et al.
7,217,291 B2	5/2007	Zucherman et al.	2004/0059318 A1	3/2004	Zhang et al.
7,235,082 B2	6/2007	Bartish et al.	2004/0073307 A1	4/2004	Keller
7,235,103 B2	6/2007	Rivin	2004/0073311 A1	4/2004	Ferree
7,250,060 B2	7/2007	Trieu	2004/0073312 A1	4/2004	Eisermann et al.
7,255,714 B2	8/2007	Malek	2004/0093087 A1	5/2004	Ferree et al.
7,261,739 B2	8/2007	Ralph et al.	2004/0097928 A1	5/2004	Zdeblick et al.
7,267,688 B2	9/2007	Ferree	2004/0098131 A1	5/2004	Bryan et al.
7,270,679 B2	9/2007	Istphanous et al.	2004/0117021 A1	6/2004	Biedermann et al.
7,270,682 B2	9/2007	Frigg et al.	2004/0138749 A1	7/2004	Zucherman et al.
7,303,583 B1	12/2007	Schaer et al.	2004/0143270 A1	7/2004	Zucherman et al.
7,318,839 B2	1/2008	Malberg et al.	2004/0143332 A1	7/2004	Krueger et al.
7,326,250 B2	2/2008	Beaurain et al.	2004/0143334 A1	7/2004	Ferree
7,331,995 B2	2/2008	Eisermann et al.	2004/0167626 A1	8/2004	Geremakis et al.
7,429,270 B2	9/2008	Baumgartner et al.	2004/0176843 A1	9/2004	Zubok et al.
7,442,211 B2	10/2008	De Villiers et al.	2004/0186569 A1	9/2004	Berry
7,452,380 B2	11/2008	Zubok et al.	2004/0215342 A1	10/2004	Suddaby
7,491,241 B2	2/2009	Errico et al.	2004/0225295 A1	11/2004	Zubok et al.
7,494,508 B2	2/2009	Zeegers et al.	2004/0225365 A1	11/2004	Eisermann et al.
7,517,363 B2	4/2009	Rogers et al.	2004/0236426 A1	11/2004	Ralph et al.
7,531,001 B2	5/2009	De Villiers et al.	2004/0254644 A1	12/2004	Taylor
7,585,326 B2	9/2009	De Villiers et al.	2005/0015094 A1	1/2005	Keller
7,637,913 B2	12/2009	De Villiers et al.	2005/0015095 A1	1/2005	Keller
			2005/0015152 A1	1/2005	Sweeney
			2005/0021145 A1	1/2005	De Villiers et al.
			2005/0021146 A1	1/2005	De Villiers et al.
			2005/0027360 A1	2/2005	Webb et al.

(56)

References Cited

U.S. PATENT DOCUMENTS

2005/0038515 A1 2/2005 Kunzler
 2005/0043800 A1 2/2005 Paul et al.
 2005/0085917 A1 4/2005 Marnay et al.
 2005/0107881 A1 5/2005 Alleyne et al.
 2005/0113842 A1 5/2005 Bertagnoli et al.
 2005/0113928 A1 5/2005 Cragg et al.
 2005/0143824 A1 6/2005 Richelsoph et al.
 2005/0149189 A1 7/2005 Mokhtar et al.
 2005/0154463 A1 7/2005 Trieu
 2005/0165408 A1 7/2005 Puno et al.
 2005/0192586 A1 9/2005 Zucherman et al.
 2005/0192670 A1 9/2005 Zubok et al.
 2005/0197706 A1 9/2005 Hovorka et al.
 2005/0216081 A1 9/2005 Taylor et al.
 2005/0216084 A1 9/2005 Fleischmann et al.
 2005/0234553 A1 10/2005 Gordon
 2005/0251260 A1 11/2005 Gerber et al.
 2005/0251261 A1 11/2005 Peterman
 2005/0251262 A1 11/2005 De Villiers et al.
 2005/0261772 A1 11/2005 Filippi et al.
 2005/0267580 A1 12/2005 Suddaby
 2005/0267581 A1 12/2005 Marnay et al.
 2006/0004377 A1 1/2006 Keller
 2006/0004453 A1 1/2006 Bartish et al.
 2006/0015183 A1 1/2006 Gilbert et al.
 2006/0020342 A1 1/2006 Ferree et al.
 2006/0025862 A1 2/2006 Villiers et al.
 2006/0029186 A1 2/2006 De Villiers et al.
 2006/0030857 A1 2/2006 De Villiers et al.
 2006/0030862 A1 2/2006 De Villiers et al.
 2006/0036325 A1 2/2006 Paul et al.
 2006/0041313 A1 2/2006 Allard et al.
 2006/0041314 A1 2/2006 Millard
 2006/0052870 A1 3/2006 Ferree
 2006/0069439 A1 3/2006 Zucherman et al.
 2006/0142858 A1 6/2006 Colleran et al.
 2006/0142862 A1 6/2006 Diaz et al.
 2006/0155378 A1 7/2006 Eckman
 2006/0167549 A1 7/2006 Mathys, Jr. et al.
 2006/0178744 A1 8/2006 De Villiers et al.
 2006/0178746 A1 8/2006 Bartish et al.
 2006/0195097 A1 8/2006 Evans et al.
 2006/0200239 A1 9/2006 Rothman et al.
 2006/0224241 A1 10/2006 Butler et al.
 2006/0235426 A1 10/2006 Lim et al.
 2006/0235525 A1 10/2006 Gil et al.
 2006/0235527 A1 10/2006 Buettner-Janx et al.
 2006/0241641 A1 10/2006 Albans et al.
 2006/0241766 A1 10/2006 Felton et al.
 2006/0259144 A1 11/2006 Trieu
 2006/0259146 A1 11/2006 Navarro et al.
 2006/0265068 A1 11/2006 Schwab
 2006/0293752 A1 12/2006 Moumene et al.
 2006/0293754 A1 12/2006 De Villiers et al.
 2007/0010826 A1 1/2007 Rhoda et al.
 2007/0021837 A1 1/2007 Ashman
 2007/0032875 A1 2/2007 Blacklock et al.
 2007/0061011 A1 3/2007 De Villiers et al.
 2007/0067035 A1 3/2007 Falahee
 2007/0067036 A1 3/2007 Hudgins et al.
 2007/0073398 A1 3/2007 Fabian et al.
 2007/0088440 A1 4/2007 Eisermann et al.
 2007/0093898 A1 4/2007 Schwab et al.
 2007/0100453 A1 5/2007 Parsons et al.
 2007/0100454 A1 5/2007 Burgess et al.
 2007/0100456 A1 5/2007 Dooris et al.
 2007/0123903 A1 5/2007 Raymond et al.
 2007/0123904 A1 5/2007 Stad et al.
 2007/0135923 A1 6/2007 Peterman et al.
 2007/0162133 A1 7/2007 Doubler et al.
 2007/0168033 A1 7/2007 Kim et al.
 2007/0168036 A1 7/2007 Ainsworth et al.
 2007/0179615 A1 8/2007 Heinz et al.
 2007/0213821 A1 9/2007 Kwak et al.
 2007/0233077 A1 10/2007 Khalili

2007/0233247 A1 10/2007 Schwab
 2007/0233248 A1 10/2007 Schwab et al.
 2007/0233251 A1 10/2007 Abdou
 2007/0270970 A1 11/2007 Trieu
 2007/0282449 A1 12/2007 De Villiers et al.
 2007/0299521 A1 12/2007 Glenn et al.
 2008/0015698 A1 1/2008 Marino et al.
 2008/0015701 A1 1/2008 Garcia et al.
 2008/0021557 A1 1/2008 Trieu
 2008/0051900 A1 2/2008 De Villiers et al.
 2008/0051901 A1 2/2008 De Villiers et al.
 2008/0125864 A1 5/2008 De Villiers et al.
 2008/0133011 A1 6/2008 De Villiers et al.
 2008/0154301 A1 6/2008 De Villiers et al.
 2008/0154382 A1 6/2008 De Villiers et al.
 2008/0215155 A1 9/2008 De Villiers et al.
 2008/0221696 A1 9/2008 De Villiers et al.
 2008/0228274 A1 9/2008 De Villiers et al.
 2008/0228277 A1 9/2008 De Villiers et al.
 2008/0294259 A1 11/2008 De Villiers et al.
 2009/0043391 A1 2/2009 De Villiers et al.
 2009/0048674 A1 2/2009 Zubok et al.
 2009/0048677 A1 2/2009 McLeod et al.
 2009/0076614 A1 3/2009 Arramon
 2009/0105833 A1 4/2009 Hovda et al.
 2009/0105834 A1 4/2009 Hovda et al.
 2009/0105835 A1 4/2009 Hovda et al.
 2009/0222101 A1 9/2009 De Villiers et al.
 2009/0276051 A1 11/2009 Arramon et al.
 2010/0004746 A1 1/2010 Arramon
 2010/0016972 A1 1/2010 Jansen et al.
 2010/0016973 A1 1/2010 De Villiers et al.
 2010/0049040 A1 2/2010 De Villiers et al.
 2010/0069976 A1 3/2010 De Villiers et al.
 2010/0076558 A1 3/2010 De Villiers et al.
 2010/0191338 A1 7/2010 De Villiers et al.
 2014/0128976 A1 5/2014 De Villiers et al.
 2016/0220380 A1 8/2016 Villiers et al.
 2016/0250035 A1 9/2016 Villiers et al.

FOREIGN PATENT DOCUMENTS

EP 0333990 A2 9/1989
 EP 0333990 A3 5/1990
 EP 0560140 A1 9/1993
 EP 0560141 A1 9/1993
 EP 0591712 A1 4/1994
 EP 0820740 A1 1/1998
 EP 1142544 A1 10/2001
 EP 1153582 A2 11/2001
 EP 1153582 A3 11/2001
 EP 1250898 A1 10/2002
 EP 1306064 A1 5/2003
 EP 1344493 A1 9/2003
 EP 1344506 A1 9/2003
 EP 1344507 A1 9/2003
 EP 1344508 A1 9/2003
 EP 1405615 A1 4/2004
 EP 1417940 A1 5/2004
 EP 1570813 A1 9/2005
 FR 2803741 A1 7/2001
 JP S61122859 A 6/1986
 JP S63164948 A 7/1988
 JP H01136655 A 5/1989
 JP H067391 A 1/1994
 JP 2002521090 A 7/2002
 JP 2003508119 A 3/2003
 WO WO-9920209 A1 4/1999
 WO WO-9930651 A1 6/1999
 WO WO-0004851 A1 2/2000
 WO WO-0035384 A1 6/2000
 WO WO-0042954 A2 7/2000
 WO WO-0042954 A3 11/2000
 WO WO-0101893 A1 1/2001
 WO WO-0115637 A1 3/2001
 WO WO-0168003 A1 9/2001
 WO WO-0211650 A2 2/2002
 WO WO-2004000170 A1 12/2003
 WO WO-2004000171 A1 12/2003

(56)

References Cited

FOREIGN PATENT DOCUMENTS

WO	WO-2004026187	A1	4/2004
WO	WO-2004054477	A1	7/2004
WO	WO-2005004756	A2	1/2005
WO	WO-2005004756	A3	5/2005
WO	WO-2005053580	A1	6/2005
WO	WO-2005072662	A1	8/2005
WO	WO-2005112834	A2	12/2005
WO	WO-2005112834	A3	5/2006
WO	WO-2006119092	A2	11/2006
WO	WO-2006119092	A3	12/2006
WO	WO-2007121320	A2	10/2007
WO	WO-2007121320	A3	6/2008
ZA	200603171		9/2007

OTHER PUBLICATIONS

Office action dated Apr. 23, 2014 for U.S. Appl. No. 14/150,437.
 Office action dated Sep. 12, 2014 for U.S. Appl. No. 14/150,437.
 Office Action dated Nov. 14, 2017 for U.S. Appl. No. 14/612,431.
 Office Action dated Jun. 19, 2017 for U.S. Appl. No. 14/612,431.
 Buttner-Janz, The Development of the Artificial Disc. Introduction, pp. 1-18, Library of Congress Catalogue No. 92-75582, ISBN 0-9635430-0-8 (1989).
 Hellier, et al., Wear Studies for Development of an Intervertebral Disc Prosthesis. Spine, vol. 17 No. 6 Supplement pp. 86-96 (1992).
 International search report dated Jul. 21, 2005 for PCT/US2005/026160.
 International search report dated Jul. 27, 2007 for PCT/US2006/002263.
 Japanese office action dated Jun. 22, 2009 for JP 2006-533469.
 Lee, et al. Impact Response of the Intervertebral Disc in a Finite-Element Model. Spine. 2000; 25(19):2431-2439.

Lehuc, et al. Shock Absorption in Lumber Disc Prosthesis. Journal of Spinal Disorders & Techniques. 2003; 16(4):346-351.
 Notice of allowance dated Mar. 20, 2013 for U.S. Appl. No. 12/030,772.
 Notice of allowance dated Mar. 21, 2013 for U.S. Appl. No. 12/464,670.
 Notice of allowance dated Mar. 22, 2010 for U.S. Appl. No. 10/855,253.
 Notice of allowance dated Jun. 10, 2014 for U.S. Appl. No. 12/626,027.
 Notice of allowance dated Sep. 7, 2017 for U.S. Appl. No. 15/583,884.
 Notice of allowance dated Mar. 14, 2017 for U.S. Appl. No. 15/151,310.
 Office action dated Mar. 21, 2014 for U.S. Appl. No. 12/626,027.
 Office action dated Apr. 4, 2007 for U.S. Appl. No. 10/855,253.
 Office action dated Apr. 4, 2012 for U.S. Appl. No. 12/464,670.
 Office action dated May 7, 2012 for U.S. Appl. No. 12/030,772.
 Office action dated Jun. 12, 2008 for U.S. Appl. No. 10/855,253.
 Office action dated Jun. 23, 2017 for U.S. Appl. No. 15/583,884.
 Office action dated Jul. 16, 2009 for U.S. Appl. No. 10/855,253.
 Office action dated Jul. 17, 2012 for U.S. Appl. No. 12/626,027.
 Office action dated Sep. 1, 2011 for U.S. Appl. No. 12/464,670.
 Office action dated Sep. 13, 2013 for U.S. Appl. No. 12/626,027.
 Office action dated Sep. 26, 2011 for U.S. Appl. No. 12/030,772.
 Office action dated Oct. 28, 2009 for U.S. Appl. No. 10/855,253.
 Office action dated Nov. 19, 2012 for U.S. Appl. No. 12/030,772.
 Office action dated Nov. 24, 2008 for U.S. Appl. No. 10/855,253.
 Office action dated Dec. 9, 2011 for U.S. Appl. No. 12/626,027.
 Office action dated Dec. 14, 2012 for U.S. Appl. No. 12/464,670.
 Office action dated Dec. 14, 2012 for U.S. Appl. No. 12/626,027.
 Office action dated Feb. 16, 2017 for U.S. Appl. No. 15/151,310.
 Office action dated Aug. 24, 2016 for U.S. Appl. No. 15/151,310.
 U.S. Appl. No. 14/612,431, filed Feb. 3, 2015.

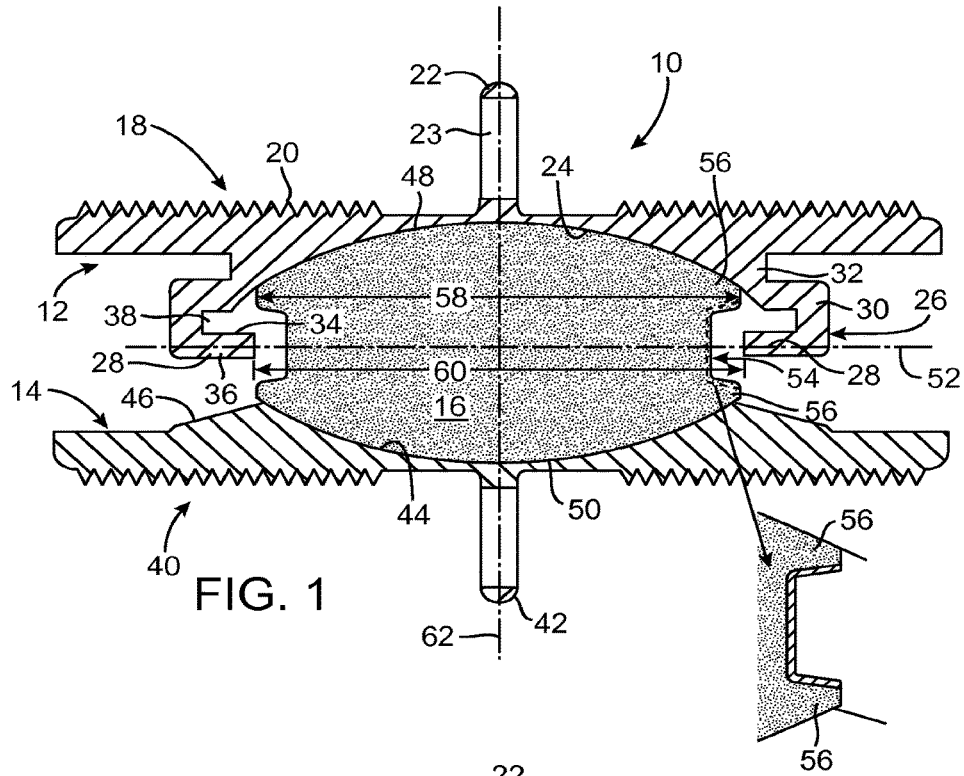

FIG. 1

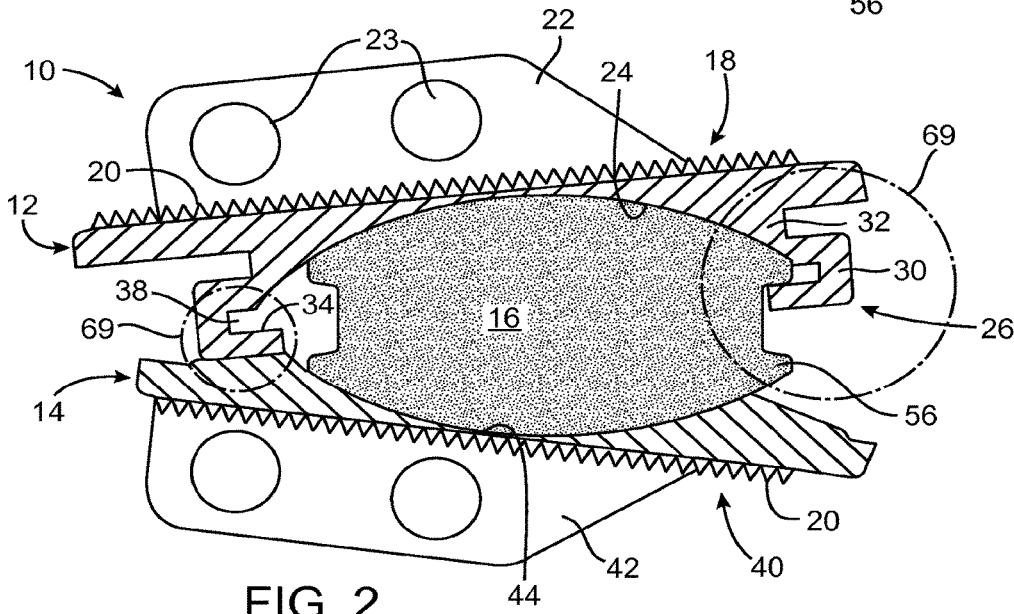

FIG. 2

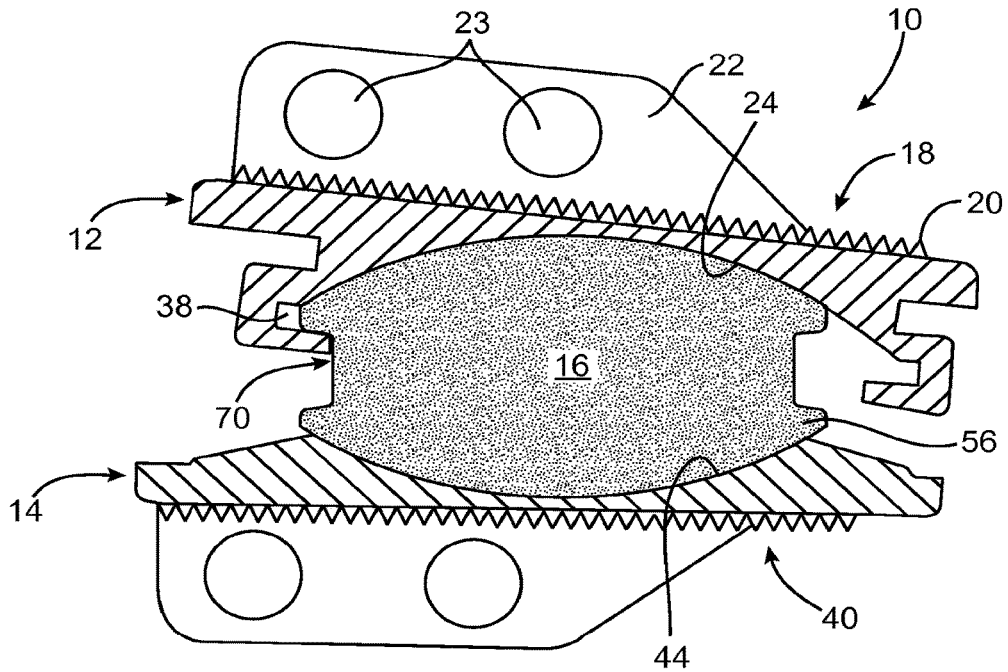

FIG. 3

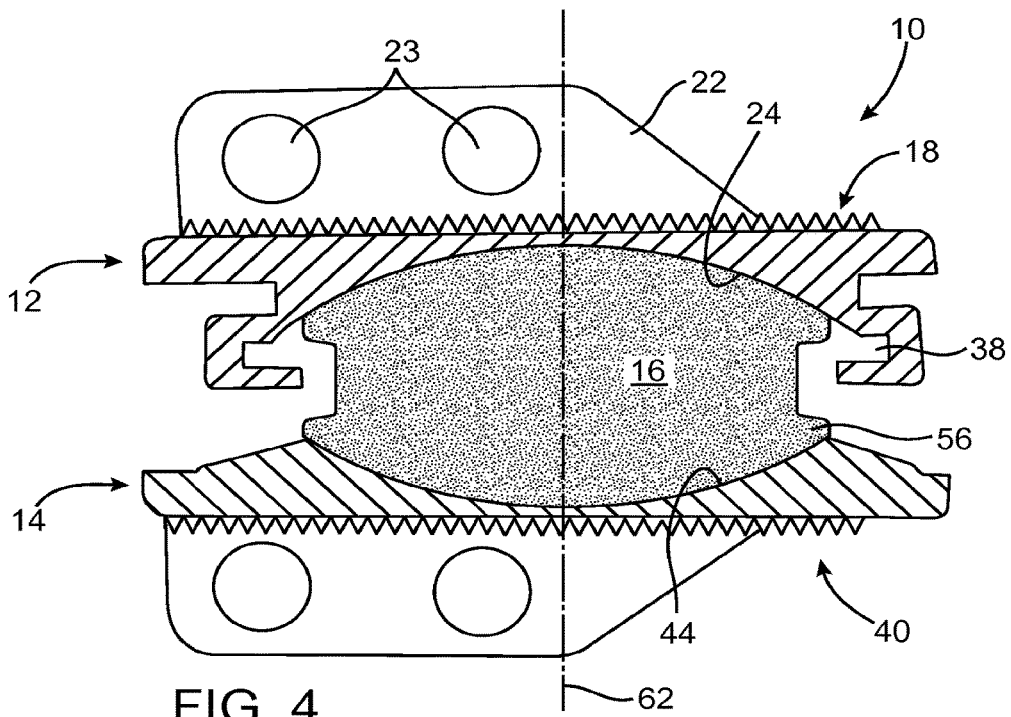

FIG. 4

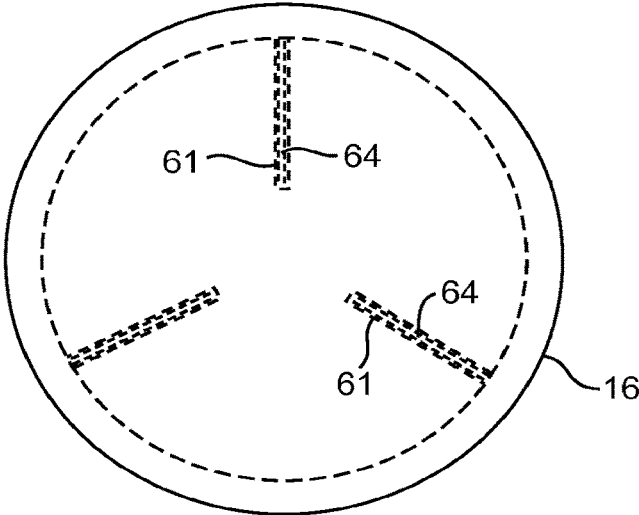

FIG. 5

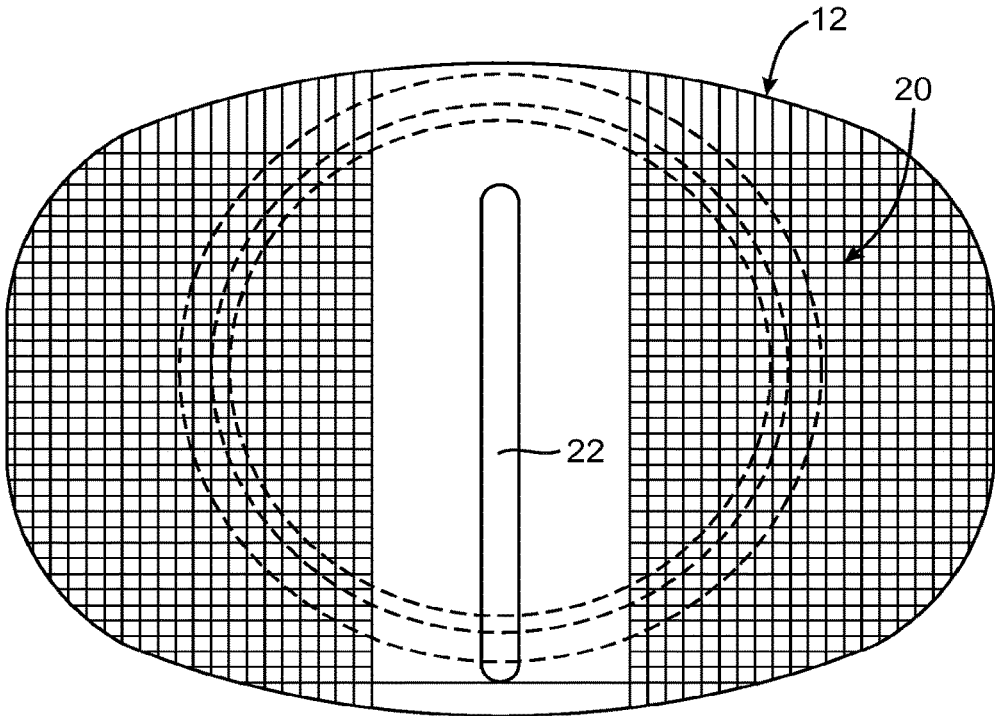

FIG. 6

PROSTHETIC DISC FOR INTERVERTEBRAL INSERTION

CROSS-REFERENCE TO RELATED APPLICATION

The present application is a continuation of U.S. patent application Ser. No. 14/612,431, filed Feb. 3, 2015, which is a continuation of U.S. patent application Ser. No. 14/150,437, filed Jan. 8, 2014, now U.S. Pat. No. 8,974,533, which is a continuation of U.S. patent application Ser. No. 12/626,027, filed Nov. 25, 2009, now U.S. Pat. No. 8,845,729, which is a continuation of U.S. patent application Ser. No. 10/855,253, filed May 26, 2004, now U.S. Pat. No. 7,753,956, which claims the benefit of U.S. Provisional No. 60/473,802, filed May 27, 2003, and U.S. Provisional No. 60/473,803, filed May 27, 2003; all of which are incorporated herein by reference in their entirety.

BACKGROUND OF THE INVENTION

1. Field of the Invention

This invention relates to medical devices and methods. More specifically, the invention relates to a prosthetic disc for intervertebral insertion, such as in the lumbar and cervical spine.

In the event of damage to a lumbar or cervical intervertebral disc, one possible surgical treatment is to replace the damaged disc with a disc prosthesis. Several types of intervertebral disc prostheses are currently available. For example, one type of intervertebral disc prosthesis is provided by Waldemar Link GmbH & Co under the trademark LINK SB CHARITE™. This prosthesis includes upper and lower prosthesis plates or shells which locate against and engage the adjacent vertebral bodies, and a low friction core between the plates. The core has upper and lower convexly curved surfaces and the plates have corresponding, concavely curved recesses which cooperate with the curved surfaces of the core. This allows the plates to slide over the core to allow required spinal movements to take place. The curved recesses in the plates are surrounded by annular ridges which locate, at the limit of sliding movement of the plates over the core, in opposing upwardly and downwardly facing, peripheral channels surrounding the curved surfaces of the core.

This type of disc configuration is described in EP 1142544A1 and EP 1250898A1, assigned to Waldemar Link GmbH & Co. A drawback of such configurations is that the provision of the peripheral ribs and channels limits the areas available for bearing and sliding contact between the plates and core, and accordingly the loads which can be transmitted by the prosthesis. As a result of the relatively small bearing areas, it is believed that at least the core will be subject to rapid wear and have a relatively short lifespan. Also, because the core is in effect merely “clamped” between the plates, this configuration does not allow for secure retention of the core. In one alternative arrangement, the curved surfaces of the core carry opposing, elongate keys that locate in elongate grooves in the plates and another alternative arrangement in which the plates have opposing elongate keys that locate in elongate grooves in the opposite curved surfaces of the core. These key and groove arrangements allow the plates to slide over the core within the limits of the length of the grooves, in one direction only. Although allowance is made for some lateral play of the keys in the grooves, very little sliding movement of the plates over the

core can take place in the orthogonal vertical plane, and this is considered to be a serious drawback of this design.

Other currently available intervertebral disc prostheses have similar and/or other drawbacks. Typically, drawbacks include insufficient resistance to wear and tear, restricted range of motion and/or insufficient ability of the prosthesis to adhere to vertebral bone.

Therefore, a need exists for improved intervertebral disc prostheses. Ideally, such improved prostheses would resist wear and tear, provide a desired range of motion and adhere well to vertebral bone. At least some of these objectives will be met by the present invention.

2. Description of the Background Art

Published US patent applications 2002/0035400A1 and 2002/0128715A1 describe disc implants which comprise opposing plates with a core between them over which the plates can slide. The core receives one or more central posts, which are carried by the plates and which locate in opposite ends of a central opening in the core. Such arrangements limit the load bearing area available between the plates and core.

Other patents related to intervertebral disc prostheses include U.S. Pat. Nos. 4,759,766; 4,863,477; 4,997,432; 5,035,716; 5,071,437; 5,370,697; 5,401,269; 5,507,816; 5,534,030; 5,556,431; 5,674,296; 5,676,702; 5,702,450; 5,824,094; 5,865,846; 5,989,291; 6,001,130; 6,022,376; 6,039,763; 6,139,579; 6,156,067; 6,162,252; 6,315,797; 6,348,071; 6,368,350; 6,416,551; 6,592,624; 6,607,558 and 6,706,068. Other patent applications related to intervertebral disc prostheses include U.S. Patent Application Publication Nos.: 2003/0009224; 2003/0074076; 2003/0191536; 2003/0208271; 2003/0135277; 2003/0199982; 2001/0016773 and 2003/0100951. Other related patents include WO 01/01893A1, EP 1344507, EP 1344506, EP 1250898, EP 1306064, EP 1344508, EP 1344493, EP 1417940, EP 1142544, and EP 0333990.

BRIEF SUMMARY OF THE INVENTION

In one aspect of the present invention, a prosthetic disc for insertion between adjacent vertebrae includes upper and lower plates having outer surfaces, which engage and are locatable against the respective vertebrae, and inner curved surfaces. A core is disposed between the curved surfaces to allow the plates to slide over the core. Preferably, the plates can slide freely in all directions, not being limited to movement in a single direction as with the prior art. The present invention further provides peripheral restraining structure on one or both of the plates or the core to hold the core against the curved surface of at least one of the plates during sliding movement of the plates over the core. The peripheral restraining structure defines a limit or boundary for movement of the core relative to at least one of the upper and lower plates. Within such a peripheral boundary, however, movement of the core relative to the plate will preferably be unconstrained. That is, movement of the core relative to the plate may occur in any direction without significant inhibition or friction. The core will preferably not be attached to either the upper or lower plate, and the plates will thus be able to freely articulate relative to each other over the core, which provides a low friction bearing surface.

An advantage of the structure thus described is that the surface contact area between the core and each of the upper and lower plates may be maximized. By providing only a peripheral restraint, as opposed for example to grooves and

keys on the surface of the core and plates, the width or diameter of the core relative to the size of the plate may be maximized. Moreover, the surfaces of the core and the plates which contact each other may be made smooth and free from other structure(s) that might adversely affect performance. In the preferred embodiments, both the curved surfaces of the plates and the corresponding surfaces of the core will be spherical sections. The use of spherical surfaces promotes free, unconstrained relative motion of the plates and the core in all directions.

In some embodiments, the peripheral restraining structure limits relative inclination of the plates during sliding movement of the plates over the core, usually by defining a stop structure. In other embodiments, the peripheral restraining structure lifts one side of the core relative to an opposite side of the core during sliding movement of the plates over the core. The peripheral restraining structure itself may take any of a number of different forms. In one embodiment, for example, the restraining structure comprises a ring structure on at least one of the upper and lower plates and an annular structure on at least a portion of the periphery of the core. The ring structure will be adapted to engage and restrain the annular structure on the core. For example, the ring structure may comprise a flange which defines an overhang over at least a portion of the periphery of one of the plates. The overhang of the flange will receive the annular structure on the core to provide an interference fit which retains the core against the curved surface of the plate but allows the core to slide freely and in an unconstrained manner within the limit or boundary defined by the flange. The annular structure on the core may be a rim which extends continuously or discontinuously (preferably continuously) around a lateral circumference of the core. By providing a rim which has a width, usually a diameter, which is slightly greater than the corresponding width of an inner edge of the flange at one point, the core will be held in place and will not be dislodged from the cavity defined by the ring structure in normal use.

Usually, the flange or other ring structure as well as the rim or other annular structure will be formed continuously about the periphery of the plate and core, respectively. Alternatively, however, either or both of the annular structure and the ring structure could be formed discontinuously. That is, so long as at least some portion of the ring structure and the annular structure remain engaged during all expected geometries and uses of the prosthetic disc, the objective of holding the core against the curved surface of the plate will be met.

The upper and lower plates may be made of any suitable material or combination of materials, such as but not limited to cobalt chrome molybdenum and titanium. In some embodiments, titanium plates are used, and these plates may optionally include inner surfaces of titanium nitride and outer surfaces that are aluminum oxide blasted to create micro-concavities. In another embodiment, cobalt chrome plates are used, with the outer surfaces being blasted with aluminum oxide and then coated with a titanium plasma spray. In some embodiments, the plates comprise an MRI-compatible material, such as titanium, coupled with a hardened material, such as cobalt chrome molybdenum. Such materials may be coupled using any suitable means, such as laminating, slip fitting, interferences fitting, adhesion, welding, molding or the like. Some plates include a coating or material on the inner surfaces for reducing friction and/or wear and tear, such as a titanium nitride surface.

Optionally, in some embodiments the outer surfaces of the upper and lower plates have at least one surface feature for promoting attachment of the outer surfaces to the vertebrae.

For example, such surface features may include a plurality of serrations disposed along the outer surfaces. Some embodiments include additional or alternative features on the outer surfaces for enhancing attachment of the prosthesis to vertebral bone, such as a material or coating, like a titanium plasma spray. Multiple micro-concavities may be formed on the outer surfaces, for example by aluminum oxide spraying, to further enhance attachment. Additionally or alternatively, the surface features may include at least one fin disposed on each of the outer surfaces. In some embodiments, the fin includes at least one hole for further promoting attachment to the vertebrae. Fins may extend vertically from their corresponding outer surfaces at right angles, or alternatively the fins may extend from their corresponding outer surface at angles other than 90°. Fins may also have any suitable orientation relative to the anterior-posterior axis of the prosthesis. For example, a fin may extend in a straight line from anterior to posterior, without being angled. Alternatively, the fin may be rotated or angled away from the anterior-posterior axis at any suitable angle between 0° and 180°. In one embodiment, each fin is disposed in a lateral orientation on the outer surfaces.

The core may generally have any suitable configuration and be made of any suitable material or combination of materials, such as polymers, ceramics or the like. In some embodiments, the core comprises a low-friction material and has two convex surfaces for slidably engaging the inner, curved surfaces of the upper and lower plates.

In another aspect of the present invention, a prosthetic disc for insertion between adjacent vertebrae includes upper and lower plates and a free-floating core disposed between the plates. Again, the upper and lower plates have outer surfaces locatable against the respective vertebrae and inner, curved surfaces. Additionally, at least one of the upper and lower plates includes a flange extending from one of the inner surfaces. The core includes at least one peripheral groove for engaging with the flange(s) to hold the core captive between the plates during sliding movement of the plates over the core. Any of the features described above may also be incorporated in various embodiments.

In another aspect of the present invention, a prosthetic disc for insertion between adjacent vertebrae includes upper and lower plates having outer surfaces locatable against the respective vertebrae and inner, curved surfaces, at least one of the upper and lower plates including a flange extending from one of the inner surfaces. A free-floating core is disposed between the curved surfaces to allow the plates to slide over the core, and the core includes at least one peripheral protrusion for engaging with the flange(s) to hold the core captive between the plates during sliding movement of the plates over the core. Again, various embodiments may include any of the features described above.

In yet another aspect of the invention, a prosthetic disc for insertion between adjacent vertebrae includes upper and lower plates having outer surfaces locatable against the respective vertebrae and inner curved surfaces, a core between the plates, and opposing retaining formations. The core includes upper and lower curved surfaces complementary in shape to the inner, curved surfaces of the plates to allow the plates to slide over the core, the upper and lower surfaces of the core being located respectively above and below an equatorial plane extending laterally through the core. The opposing retaining formations are located peripherally on the equatorial plane of the core and at an edge of the curved surface of at least one of the plates and serve to hold the core captive between the plates during sliding movement of the plates over the core.

In yet another aspect of the invention, a method for restraining spacing between adjacent vertebrae involves implanting an upper plate against a lower surface of an upper vertebral body, implanting a lower plate against an upper surface of a lower vertebral body, and disposing a core between the upper and lower plates. The core floats between spherical cavities in each of the upper and lower plates, the plates restraining peripheral movement of the core using at least one peripheral restraining member. In some embodiments, implanting each of the plates comprises sliding a fin on each plate into a corresponding groove formed in its respective vertebral body. The fin may slide into the groove in any suitable direction, such as posterior-anterior, anterior-posterior, lateral, or any angled direction between an anterior-posterior orientation and a lateral orientation. Optionally, implanting may further involve contacting textured outer surfaces of the upper and lower plates with the upper and lower surfaces of the vertebral bodies.

In another aspect of the invention, a method for assembling a prosthetic disc for insertion between adjacent vertebrae involves movably coupling a core with a first endplate to form an interference fit between the core and the first endplate and contacting the core with a second endplate. In some embodiments, coupling the core with the first endplate comprises snap fitting the core into the endplate. Alternatively, coupling the core with the first endplate may comprise forming the endplate around the core. In some embodiments, coupling the core with the first endplate involves engaging a peripheral protrusion of the core with a peripheral restraining structure of the first endplate.

These and other aspects and embodiments will be described in further detail below, with reference to the drawing figures.

BRIEF DESCRIPTION OF THE DRAWINGS

FIG. 1 shows a cross-sectional anterior view of a prosthetic disc with the prosthesis plates and core in vertical alignment, according to one embodiment of the present invention;

FIG. 2 shows a side view of the prosthetic disc in FIG. 1 after sliding movement of the plates over the core;

FIG. 3 shows a side view of the prosthetic disc in FIG. 1 after translational movement of the plates relative to the core;

FIG. 4 shows a side view of the prosthetic disc in FIG. 1 with the prosthesis plates and core in vertical alignment;

FIG. 5 shows a plan view of a core of a prosthetic disc, according to one embodiment of the present invention; and

FIG. 6 shows a plan view of an upper plate of a prosthetic disc, according to one embodiment of the present invention.

DETAILED DESCRIPTION OF THE INVENTION

FIGS. 1 to 4 illustrate a prosthetic disc 10 for intervertebral insertion between two adjacent spinal vertebrae (not shown). The disc 10 comprises three components, namely an upper plate or shell 12, a lower plate or shell 14 and a core 16 located between the plates.

The upper plate 12 includes an outer surface 18 and an inner surface 24 and may be constructed from any suitable material or combination of materials, such as but not limited to cobalt chrome molybdenum, titanium (such as grade 5 titanium) and/or the like. In one embodiment, typically used in the lumbar spine, the upper plate 12 is constructed of cobalt chrome molybdenum, and the outer surface 18 is

treated with aluminum oxide blasting followed by a titanium plasma spray. In another embodiment, typically used in the cervical spine, the upper plate 12 is constructed of titanium, the inner surface 24 is coated with titanium nitride, and the outer surface 18 is treated with aluminum oxide blasting. An alternative cervical spine embodiment includes no coating on the inner surface 24. In some embodiments, it may be useful to couple two materials together to form the inner surface 24 and the outer surface 18. For example, the upper plate 12 may be made of an MRI-compatible material, such as titanium, but may include a harder material, such as cobalt chrome molybdenum, for the inner surface 24. Any suitable technique may be used to couple materials together, such as snap fitting, slip fitting, lamination, interference fitting, use of adhesives, welding and/or the like. Any other suitable combination of materials and coatings may be employed in various embodiments of the invention.

In some embodiments, the outer surface 18 is planar. Oftentimes, the outer surface 18 will include one or more surface features and/or materials to enhance attachment of the prosthesis 10 to vertebral bone. For example, the outer surface 18 may be machined to have a serrations 20 or other surface features for promoting adhesion of the upper plate 12 to a vertebra. In the embodiment shown (FIG. 6), the serrations 20 extend in mutually orthogonal directions, but other geometries would also be useful. Additionally, the outer surface 18 may be provided with a rough microfinish formed by blasting with aluminum oxide microparticles or the like. In some embodiments, the outer surface may also be titanium plasma sprayed to further enhance attachment of the outer surface 18 to vertebral bone.

The outer surface 18 may also carry an upstanding, vertical fin 22 extending in an anterior-posterior direction. The fin 22 is pierced by transverse holes 23. In alternative embodiments, the fin 22 may be rotated away from the anterior-posterior axis, such as in a lateral-lateral orientation, a posterolateral-anterolateral orientation, or the like. In some embodiments, the fin 22 may extend from the surface 18 at an angle other than 90°. Furthermore, multiple fins 22 may be attached to the surface 18 and/or the fin 22 may have any other suitable configuration, in various embodiments. In other embodiments, the fin 22 In some embodiments, such as discs 10 for cervical insertion, the fins 22, 42 may be omitted altogether.

The inner, spherically curved concave surface 24 is formed at a central, axial position with a circular recess 26 as illustrated. At the outer edge of the curved surface 24, the upper plate 12 carries peripheral restraining structure comprising an integral ring structure 26 including an inwardly directed rib or flange 28. The flange 28 forms part of a U-shaped member 30 joined to the major part of the plate by an annular web 32. The flange 28 has an inwardly tapering shape and defines upper and lower surfaces 34 and 36 respectively which are inclined slightly relative to the horizontal when the upper plate 12 is at the orientation seen in FIG. 1. An overhang 38 of the U-shaped member 30 has a vertical dimension that tapers inwardly as illustrated.

The lower plate 14 is similar to the upper plate 12 except for the absence of the peripheral restraining structure 26. Thus, the lower plate 14 has an outer surface 40 which is planar, serrated and microfinished like the outer surface 18 of the upper plate 12. The lower plate 14 optionally carries a fin 42 similar to the fin 22 of the upper plate. The inner surface 44 of the lower plate 14 is concavely, spherically curved with a radius of curvature matching that of the inner surface 24 of the upper plate 12. Once again, this surface may be provided with a titanium nitride or other finish.

At the outer edge of the inner curved surface **44**, the lower plate **14** is provided with an inclined ledge formation **46**. Alternatively, the lower plate **14** may include peripheral restraining structure analogous to the peripheral restraining structure **26** on the upper plate **12**.

The core **16** of the disc **10** is made of a low-friction material, such as polyethylene (Chirulen™). In alternative embodiments, the core **16** may comprise any other suitable material, such as other polymers, ceramics or the like. The core **16** has identical upper and lower spherically curved convex surfaces **48**, **50**. The radius of curvature of these surfaces matches the radius of curvature of the inner surfaces **24**, **44** of the upper and lower plates **12**, **14**. The curved surfaces are accordingly complementary. For wear resistance, the surface zones of the core may be hardened by an appropriate cross-linking procedure.

The core **16** is symmetrical about a central, equatorial plane **52** which bisects it laterally. (Although in other embodiments, the core **16** may be asymmetrical.) Lying on this equatorial plane is an annular recess or groove **54** which extends about the periphery of the core. The groove **54** is defined between upper and lower ribs or lips **56**. When the plates **12**, **14** and core **16** are assembled and in the orientation seen in FIG. 1, the flange **28** lies on the equatorial plane and directly aligned with the groove **54**. The outer diameter **58** of the lips **56** is preferably very slightly larger than the diameter **60** defined by the inner edge of the flange **28**. Assembly of the core and upper plate may involve pressing the core through the circular aperture defined by the flange **28**, with the inherent resilience of the core allowing the minor deformation of the upper rib **56**, or that the core be introduced at an inclination. In other less preferred embodiments of the invention (not shown), the diameter **58** may be equal to or even slightly less than the diameter **60**.

In some embodiments, the inner surface of the groove **54** may be provided, for wear resistance, with a lining of pure titanium or titanium impregnated with cobalt chrome, titanium nitride, other titanium alloy or the like.

The central axis of the disc **10** (the axis passing through the centers of curvature of the curved surfaces) is indicated with the reference numeral **62**. As shown in FIG. 1, the disc **10** may be symmetrical about a central anterior-posterior plane containing the axis **62**. Referring to FIG. 4, in some embodiments the axis **62** is posteriorly disposed, i.e. is located closer to the posterior limit of the disc than the anterior limit thereof.

In use, the disc **10** is surgically implanted between adjacent spinal vertebrae in place of a damaged disc. The adjacent vertebrae are forcibly separated from one another to provide the necessary space for insertion. The disc is inserted, normally in a posterior direction, into place between the vertebrae with the fins **22**, **42** of the plates **12**, **14** entering slots cut in the opposing vertebral surfaces to receive them. After insertion, the vertebrae, facets, adjacent ligaments and soft tissues are allowed to move together to hold the disc in place. The serrated and microfinished surfaces **18**, **40** of the plates **12**, **14** locate against the opposing vertebrae. The serrations **20** and fins **22**, **42** provide initial stability and fixation for the disc **10**. With passage of time, enhanced by the titanium surface coating, firm connection between the plates and the vertebrae will be achieved as bone tissue grows over the serrated surface. Bone tissue growth will also take place about the fins **22**, **40** and through the transverse holes **23** therein, further enhancing the connection which is achieved.

Referring to FIG. 5, the core **16** may be formed with narrow, angularly spaced, blind passages **61** which accom-

modate titanium pins **64**. In many embodiments, the core **16** itself is transparent to X-radiation and so is invisible in a post-operative X-ray examination. The pins **64** serve as radiographic markers and enable the position of the core **16** to be ascertained during such examination.

In the assembled disc **10**, the complementary and cooperating spherical surfaces of the plates and core allow the plates to slide or articulate over the core through a fairly large range of angles and in all directions or degrees of freedom, including rotation about the central axis **62**. FIGS. 1 and 4 show the disc **10** with the plates **12** and **14** and core **16** aligned vertically with one another on the axis **62**. FIG. 2 illustrates a situation where maximum anterior flexion of the disc **10** has taken place. At this position, the upper rib **56** has entered the hollow **38** of the U-shaped member **30**, the lower surface of the rib **56** has moved into contact with the upper surface **34** of the flange **28**, the flange having moved into the groove **54**, and the lower surface **36** of the flange has moved into contact with the upper surface of the ledge formation **46**, as will be seen in the encircled areas **69**. Abutment between the various surfaces prevents further anterior flexure. The design also allows for the inner extremity of the flange **28** to abut against the base of the groove **54**, thereby limiting further relative movement between the core and plate. A similar configuration is achieved in the event of maximum posterior flexure of the plates **12**, **14** over the core, such as during spinal extension and/or in the event of maximum lateral flexure.

FIG. 3 illustrates how the disc **10** can also allow for translational movement of the plates relative to the core. In the illustrated situation there has been lateral translation of the plates relative to the core. The limit of lateral translation is reached when the inner extremity of the flange **28** abuts the base of the groove **54** as indicated by the numeral **70**.

The flange **28** and the groove **54** defined between the ribs **56**, prevent separation of the core from the plates. In other words, the cooperation of the retaining formations ensures that the core is held captive between the plates at all times during flexure of the disc **10**.

In an alternative embodiment, the continuous annular flange **28** may be replaced by a retaining formation comprising a number of flange segments which are spaced apart circumferentially. Such an embodiment could include a single, continuous groove **54** as in the illustrated embodiment. Alternatively, a corresponding number of groove-like recesses spaced apart around the periphery of the core could be used, with each flange segment opposing one of the recesses. In another embodiment, the continuous flange or the plurality of flange segments could be replaced by inwardly directed pegs or pins carried by the upper plate **12**. This embodiment could include a single, continuous groove **54** or a series of circumferentially spaced recesses with each pin or peg opposing a recess.

In yet another embodiment, the retaining formation(s) could be carried by the lower plate **14** instead of the upper plate, i.e. the plates are reversed. In some embodiments, the upper (or lower) plate is formed with an inwardly facing groove, or circumferentially spaced groove segments, at the edge of its inner, curved surface, and the outer periphery of the core is formed with an outwardly facing flange or with circumferentially spaced flange segments.

Although the foregoing is a complete and accurate description of the invention, any of a number of modifications, additions or the like may be made to the various embodiments without departing from the scope of the inven-

tion. Therefore, nothing described above should be interpreted as limiting the scope of the invention at it is described in the claims.

What is claimed is:

1. A method of making assembling a prosthetic disc with a mobile core, the method comprising:

providing a first plate having a first surface configured to engage a vertebra and an opposite bearing surface;

providing a second plate having a first surface configured to engage a vertebra and an opposite bearing surface;

providing a rigid mobile core, the core having first and second bearing surfaces configured to cooperate with the bearing surfaces of the first and second plates to allow the first and second plates to slide and translate over the core when implanted between adjacent spinal vertebrae and a lateral edge between the first and second bearing surfaces;

further providing on said rigid mobile core, two or more recesses circumferentially spaced apart about the periphery of the core; and

further providing on said first plate two or more pegs, each peg opposing one of the two or more circumferentially spaced recesses, wherein the two or more circumferentially spaced recesses extend in a direction radially inward from the lateral edge of the core toward a center portion of the core; and

assembling the mobile core between the first and second plates to form an assembled configuration for implantation between adjacent spinal vertebrae in which the core is retained between the first and second plates with the two or more pegs received in the spaced apart recesses.

2. A method as in claim 1, wherein the pegs are configured to extend into the recesses during sliding motion of the plates over the core.

3. A method as in claim 1, wherein the second bearing surface of the core is spherical.

4. A method as in claim 3, wherein the bearing surface of the second plate is a concave spherical surface which matches a curvature of the spherical surface of the core.

5. A method as in claim 1, wherein both of the first and second bearing surfaces of the core are spherical.

6. A method as in claim 1, wherein the core has a substantially circular perimeter.

7. A method as in claim 1, wherein the core is symmetrical about a central, equatorial plane which bisects the core laterally.

8. A method as in claim 1, wherein the lateral edge is a continuous lateral edge.

9. A method as in claim 1, wherein cooperation between the recesses and the pegs ensures that the core is held captive between the plates upon implantation between adjacent spinal vertebrae.

10. A method as in claim 1, wherein the assembled configuration allows anterior, posterior and lateral motion of the core with respect to the first plate.

11. A method as in claim 1, wherein the assembled configuration allows anterior, posterior and lateral motion of the core with respect to the second plate.

12. A method as in claim 1, wherein the two or more recesses are surrounded by recess surfaces of the core and wherein assembling the first and second plates and the mobile core comprises passing outwardly facing portions of the recesses surfaces of the core through opposing inwardly facing surfaces of the two or more pegs on the first plate to restrain peripheral movement of the core.

13. A method as in claim 1, wherein the two or more pegs are configured to retain the core in the assembled configuration for implantation between adjacent spinal vertebrae but allow the core to slide within a limit defined by the two or more recesses when implanted between adjacent spinal vertebrae.

14. A method as in claim 1, wherein the two or more pegs are configured to retain the core in the assembled configuration while allowing lateral translation of the core and preventing the core from extending laterally beyond the plates when the assembled prosthetic disc is implanted between adjacent spinal vertebrae.

* * * * *