



US011229526B2

(12) **United States Patent**
de Villiers et al.

(10) **Patent No.:** **US 11,229,526 B2**
(45) **Date of Patent:** ***Jan. 25, 2022**

(54) **CUSTOMIZED INTERVERTEBRAL PROSTHETIC DISC WITH SHOCK ABSORPTION**

(58) **Field of Classification Search**

CPC A61F 2/442; A61F 2/4425
See application file for complete search history.

(71) Applicant: **Simplify Medical Pty Ltd**, Sunnyvale, CA (US)

(56) **References Cited**

U.S. PATENT DOCUMENTS

3,486,505 A 12/1969 Gordon
3,867,728 A 2/1975 Stubstad et al.
(Continued)

(72) Inventors: **Malan de Villiers**, Wapadrand (ZA);
David Hovda, Mountain View, CA (US); **James Shapiro**, San Francisco, CA (US)

FOREIGN PATENT DOCUMENTS

DE 3023353 A1 4/1981
DE 10035182 A1 2/2002
(Continued)

(73) Assignee: **Simplify Medical Pty Ltd.**, Sunnyvale, CA (US)

(*) Notice: Subject to any disclaimer, the term of this patent is extended or adjusted under 35 U.S.C. 154(b) by 222 days.

This patent is subject to a terminal disclaimer.

OTHER PUBLICATIONS

Buttner-Janz, The Development of the Artificial Disc. Introduction, pp. 1-18, Library of Congress Catalogue No. 92-75582, ISBN 0-9635430-0-8 (1989).

(Continued)

(21) Appl. No.: **16/705,894**

Primary Examiner — Christian A Sevilla

(22) Filed: **Dec. 6, 2019**

(74) *Attorney, Agent, or Firm* — Hoffman Warnick LLC

(65) **Prior Publication Data**

US 2020/0107939 A1 Apr. 9, 2020

Related U.S. Application Data

(60) Continuation of application No. 15/795,184, filed on Oct. 26, 2017, now Pat. No. 10,548,739, which is a (Continued)

(57) **ABSTRACT**

A prosthesis system comprises plates that can be positioned against vertebrae and a selected resilient core that can be positioned between the plates to allow the plates to articulate. The selected resilient core can be chosen from a plurality of cores in response to patient characteristics, such as age and/or intervertebral mobility, such that the prosthesis implanted in the patient is tailored to the needs of the patient. The plurality of cores may comprise cores with different resiliencies, and one of the cores can be selected such that the upper and lower plates articulate with the desired shock absorbing resiliency and/or maximum angle of inclination when the one selected core is positioned between the plates.

(51) **Int. Cl.**

A61F 2/44 (2006.01)
A61F 2/46 (2006.01)
A61F 2/30 (2006.01)

(52) **U.S. Cl.**

CPC **A61F 2/4425** (2013.01); **A61F 2/442** (2013.01); **A61F 2/447** (2013.01); **A61F 2/4611** (2013.01);

(Continued)

20 Claims, 10 Drawing Sheets

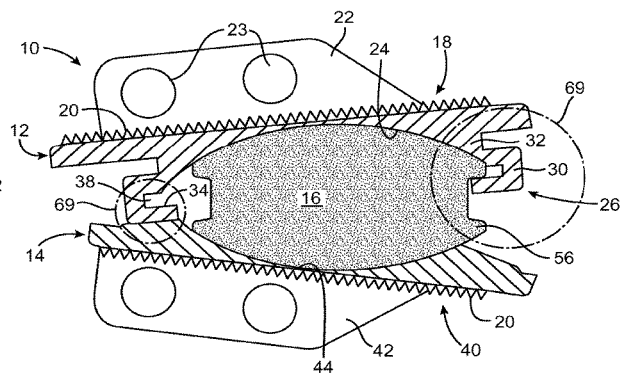
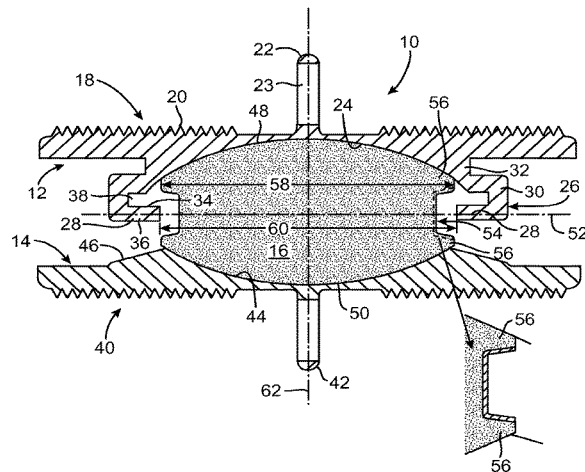

Related U.S. Application Data

continuation of application No. 15/606,587, filed on May 26, 2017, now Pat. No. 9,827,108, which is a continuation of application No. 15/368,437, filed on Dec. 2, 2016, now Pat. No. 9,687,355, which is a continuation of application No. 13/941,121, filed on Jul. 12, 2013, now Pat. No. 9,554,917, which is a division of application No. 12/883,068, filed on Sep. 15, 2010, now Pat. No. 8,506,631, which is a division of application No. 11/836,684, filed on Aug. 9, 2007, now abandoned.

(52) U.S. Cl.

CPC . *A61F 2002/305* (2013.01); *A61F 2002/3071* (2013.01); *A61F 2002/30383* (2013.01); *A61F 2002/30405* (2013.01); *A61F 2002/30495* (2013.01); *A61F 2002/30563* (2013.01); *A61F 2002/30568* (2013.01); *A61F 2002/30579* (2013.01); *A61F 2002/30601* (2013.01); *A61F 2002/30616* (2013.01); *A61F 2002/30617* (2013.01); *A61F 2002/30662* (2013.01); *A61F 2002/30663* (2013.01); *A61F 2002/30673* (2013.01); *A61F 2002/30841* (2013.01); *A61F 2002/30884* (2013.01); *A61F 2002/30899* (2013.01); *A61F 2002/30904* (2013.01); *A61F 2002/443* (2013.01); *A61F 2002/4628* (2013.01); *A61F 2220/0025* (2013.01); *A61F 2250/0085* (2013.01); *A61F 2310/0017* (2013.01); *A61F 2310/0023* (2013.01); *A61F 2310/0029* (2013.01); *A61F 2310/00179* (2013.01); *A61F 2310/00407* (2013.01)

(56)**References Cited**

U.S. PATENT DOCUMENTS

4,309,777	A	1/1982	Patil	5,534,030	A	7/1996	Navarro et al.
4,531,917	A	7/1985	Linkow et al.	5,556,431	A	9/1996	Büttner-Janz
4,566,466	A	1/1986	Ripple et al.	5,665,122	A	9/1997	Kambin
4,619,660	A	10/1986	Christiansen et al.	5,674,296	A	10/1997	Bryan et al.
4,673,407	A	6/1987	Martin	5,676,701	A	10/1997	Yuan et al.
4,759,766	A	7/1988	Buettner-Janz et al.	5,676,702	A	10/1997	Ratron
4,759,769	A	7/1988	Hedman et al.	5,683,465	A	11/1997	Shinn et al.
4,834,757	A	5/1989	Brantigan	5,702,450	A	12/1997	Bisserie
4,863,477	A	9/1989	Monson	5,709,683	A	1/1998	Bagby
4,904,261	A	2/1990	Dove et al.	5,728,159	A	3/1998	Stroeveer et al.
4,917,704	A	4/1990	Frey et al.	5,741,253	A	4/1998	Michelson
4,932,969	A	6/1990	Frey et al.	5,776,198	A	7/1998	Rabbe et al.
4,946,378	A	8/1990	Hirayama et al.	5,782,832	A	7/1998	Larsen et al.
4,997,432	A	3/1991	Keller et al.	5,797,909	A	8/1998	Michelson
5,035,716	A	7/1991	Downey	5,824,094	A	10/1998	Serhan et al.
5,057,108	A	10/1991	Shetty et al.	5,836,948	A	11/1998	Zucherman et al.
5,071,437	A	12/1991	Steffee	5,865,846	A	2/1999	Bryan et al.
5,122,130	A	6/1992	Keller	5,865,848	A	2/1999	Baker
5,195,526	A	3/1993	Michelson	5,888,226	A	3/1999	Rogozinski
5,258,031	A	11/1993	Salib et al.	5,895,428	A	4/1999	Berry
5,282,661	A	2/1994	Arnberger	5,899,901	A	5/1999	Middleton
5,306,308	A	4/1994	Gross et al.	5,899,911	A	5/1999	Carter
5,314,477	A	5/1994	Marnay	5,928,284	A	7/1999	Mehdizadeh
5,320,644	A	6/1994	Baumgartner	5,989,251	A	11/1999	Nichols
5,370,697	A	12/1994	Baumgartner et al.	5,989,291	A	11/1999	Ralph et al.
5,394,457	A	2/1995	Leibinger et al.	6,001,130	A	12/1999	Bryan et al.
5,401,269	A	3/1995	Buettner-Janz et al.	6,019,792	A	2/2000	Cauthen
5,415,704	A	5/1995	Davidson	6,022,376	A	2/2000	Assell et al.
5,458,642	A	10/1995	Beer et al.	6,039,761	A	3/2000	Li et al.
5,462,575	A	10/1995	Del Corso	6,039,763	A	3/2000	Shelokov
5,484,437	A	1/1996	Michelson	6,080,155	A	6/2000	Michelson
5,489,307	A	2/1996	Kuslich et al.	6,083,228	A	7/2000	Michelson
5,505,732	A	4/1996	Michelson	6,086,613	A	7/2000	Camino et al.
5,507,816	A	4/1996	Bullivant	6,096,038	A	8/2000	Michelson
				6,102,950	A	8/2000	Vaccaro
				6,132,465	A	10/2000	Ray et al.
				6,136,031	A	10/2000	Middleton
				6,139,551	A	10/2000	Michelson et al.
				6,139,579	A	10/2000	Steffee et al.
				6,143,033	A	11/2000	Paul et al.
				6,146,421	A	11/2000	Gordon et al.
				6,156,067	A	12/2000	Bryan et al.
				6,159,214	A	12/2000	Michelson
				6,162,252	A	12/2000	Kuras et al.
				6,174,311	B1	1/2001	Branch et al.
				6,176,881	B1	1/2001	Schaer et al.
				6,193,757	B1	2/2001	Foley et al.
				6,224,595	B1	5/2001	Michelson
				6,224,607	B1	5/2001	Michelson
				6,231,609	B1	5/2001	Mehdizadeh
				6,235,030	B1	5/2001	Zucherman et al.
				6,261,296	B1	7/2001	Aebi et al.
				6,264,695	B1	7/2001	Stoy
				6,290,726	B1	9/2001	Pope et al.
				6,296,664	B1	10/2001	Middleton
				6,315,797	B1	11/2001	Middleton
				6,322,567	B1	11/2001	Mittelstadt et al.
				6,336,941	B1	1/2002	Subba et al.
				6,348,071	B1	2/2002	Steffee et al.
				6,368,350	B1	4/2002	Erickson et al.
				6,368,351	B1	4/2002	Glenn et al.
				6,375,681	B1	4/2002	Truscott
				6,375,682	B1	4/2002	Fleischmann et al.
				6,395,032	B1	5/2002	Gauchet
				6,402,785	B1	6/2002	Zdeblick et al.
				6,409,766	B1	6/2002	Brett
				6,413,278	B1	7/2002	Marchosky
				6,416,551	B1	7/2002	Keller
				6,436,098	B1	8/2002	Michelson
				6,440,139	B2	8/2002	Michelson
				6,447,544	B1	9/2002	Michelson
				6,478,800	B1	11/2002	Fraser et al.
				6,517,544	B1	2/2003	Michelson
				6,517,580	B1	2/2003	Ramadan et al.
				6,520,967	B1	2/2003	Cauthen
				6,520,996	B1	2/2003	Manasas et al.
				6,527,804	B1	3/2003	Gauchet et al.
				6,533,817	B1	3/2003	Norton et al.
				6,537,279	B1	3/2003	Michelson

(56)

References Cited

U.S. PATENT DOCUMENTS

6,554,863	B2	4/2003	Paul et al.	7,182,784	B2	2/2007	Evans et al.	
6,562,047	B2	5/2003	Ralph et al.	7,198,644	B2	4/2007	Schultz et al.	
6,562,074	B2	5/2003	Gerbec et al.	7,207,991	B2	4/2007	Michelson	
6,565,574	B2	5/2003	Michelson	7,214,244	B2	5/2007	Zubok et al.	
6,582,466	B1	6/2003	Gauchet	7,217,291	B2	5/2007	Zucherman et al.	
6,582,468	B1	6/2003	Gauchet	7,235,082	B2	6/2007	Bartish et al.	
6,592,624	B1	7/2003	Fraser et al.	7,235,103	B2	6/2007	Rivin	
6,599,294	B2	7/2003	Fuss et al.	7,250,060	B2	7/2007	Trieu	
6,607,558	B2	8/2003	Kuras	7,255,714	B2	8/2007	Malek	
6,607,559	B2	8/2003	Ralph et al.	7,261,739	B2	8/2007	Ralph et al.	
6,610,092	B2	8/2003	Ralph et al.	7,267,688	B2	9/2007	Ferree	
6,623,525	B2	9/2003	Ralph et al.	7,270,679	B2	9/2007	Istephanous et al.	
6,645,248	B2	11/2003	Casutt	7,270,682	B2	9/2007	Frigg et al.	
6,648,895	B2	11/2003	Burkus et al.	7,303,582	B2	12/2007	Brady et al.	
6,652,533	B2	11/2003	O'Neil	7,303,583	B1	12/2007	Schaer et al.	
6,660,038	B2	12/2003	Boyer et al.	7,318,839	B2	1/2008	Malberg et al.	
6,666,866	B2	12/2003	Martz et al.	7,326,250	B2	2/2008	Beaurain et al.	
6,669,731	B2	12/2003	Ralph et al.	7,331,995	B2	2/2008	Eisermann et al.	
6,669,732	B2	12/2003	Serhan et al.	7,429,270	B2	9/2008	Baumgartner	
6,673,113	B2	1/2004	Ralph et al.	7,442,211	B2	10/2008	de Villiers et al.	
6,682,562	B2	1/2004	Viart et al.	7,452,380	B2	11/2008	Zubok et al.	
6,689,132	B2	2/2004	Biscup	7,491,241	B2	2/2009	Errico et al.	
6,706,068	B2	3/2004	Ferree	7,494,508	B2	2/2009	Zeegers et al.	
6,709,439	B2	3/2004	Rogers et al.	7,517,363	B2	4/2009	Rogers et al.	
6,712,819	B2	3/2004	Zucherman et al.	7,549,995	B2	6/2009	Schultz	
6,712,825	B2	3/2004	Aebi et al.	7,563,286	B2	7/2009	Gerber et al.	
6,719,794	B2	4/2004	Gerber et al.	7,601,174	B2	10/2009	Kelly et al.	
6,723,097	B2	4/2004	Fraser et al.	7,621,856	B1 *	11/2009	Keith A01K 27/004 119/796	
6,726,720	B2	4/2004	Ross et al.	7,682,396	B2 *	3/2010	Beaurain A61F 2/4425 623/17.14	
6,726,721	B2	4/2004	Stoy et al.	7,708,776	B1	5/2010	Blain et al.	
6,733,532	B1	5/2004	Gauchet et al.	7,731,753	B2	6/2010	Reo et al.	
6,740,118	B2	5/2004	Eisermann et al.	7,909,876	B2	3/2011	Dooris et al.	
6,740,119	B2	5/2004	Ralph et al.	7,917,374	B2 *	3/2011	Walker G16H 50/20 705/2	
6,752,832	B2	6/2004	Neumann	8,038,715	B2	10/2011	Kim et al.	
6,755,841	B2	6/2004	Fraser et al.	8,277,508	B2	10/2012	Trieu	
6,764,512	B2	7/2004	Keller	8,388,681	B2	3/2013	Paul et al.	
6,764,515	B2	7/2004	Ralph et al.	8,506,631	B2	8/2013	De et al.	
6,770,095	B2	8/2004	Grinberg et al.	8,858,635	B2 *	10/2014	Hovorka A61F 2/4611 623/17.15	
6,790,233	B2	9/2004	Brodke et al.	9,554,917	B2	1/2017	De et al.	
6,793,678	B2	9/2004	Hawkins	9,687,355	B2	6/2017	De et al.	
6,814,737	B2	11/2004	Cauthen	10,548,739	B2	2/2020	Villiers	
6,821,298	B1	11/2004	Jackson	2001/0016773	A1	8/2001	Serhan et al.	
6,827,740	B1	12/2004	Michelson	2001/0029377	A1	10/2001	Aebi et al.	
6,830,570	B1	12/2004	Frey et al.	2002/0022845	A1	2/2002	Zdeblick et al.	
6,846,328	B2	1/2005	Cauthen	2002/0035400	A1	3/2002	Bryan et al.	
6,852,126	B2	2/2005	Ahlgren	2002/0045904	A1	4/2002	Fuss et al.	
6,863,673	B2	3/2005	Gerbec et al.	2002/0068936	A1	6/2002	Burkus et al.	
6,875,213	B2	4/2005	Michelson	2002/0091392	A1	7/2002	Michelson	
6,896,680	B2	5/2005	Michelson	2002/0116009	A1	8/2002	Fraser et al.	
6,899,735	B2	5/2005	Coates et al.	2002/0123753	A1	9/2002	Michelson	
6,936,071	B1	8/2005	Marnay et al.	2002/0128714	A1 *	9/2002	Manasas B29C 64/153 623/17.15	
6,936,132	B2	8/2005	Topolnitsky	2002/0128715	A1	9/2002	Bryan et al.	
6,964,686	B2	11/2005	Gordon	2002/0130112	A1 *	9/2002	Manasas B22F 10/20 219/121.64	
6,966,929	B2	11/2005	Mitchell	2002/0165550	A1	11/2002	Frey et al.	
6,966,931	B2	11/2005	Huang	2002/0177897	A1	11/2002	Michelson	
6,986,788	B2	1/2006	Paul et al.	2002/0198532	A1	12/2002	Michelson	
6,989,011	B2	1/2006	Paul et al.	2003/0009224	A1	1/2003	Kuras	
6,994,727	B2	2/2006	Khandkar et al.	2003/0023245	A1	1/2003	Ralph et al.	
7,011,684	B2	3/2006	Eckman	2003/0028249	A1	2/2003	Baccelli et al.	
7,022,138	B2	4/2006	Mashburn	2003/0040746	A1	2/2003	Mitchell et al.	
7,025,787	B2	4/2006	Bryan et al.	2003/0045884	A1	3/2003	Robie et al.	
7,044,983	B1	5/2006	Cheng	2003/0045939	A1	3/2003	Casutt	
7,056,344	B2	6/2006	Huppert et al.	2003/0074076	A1	4/2003	Ferree et al.	
7,060,073	B2	6/2006	Frey et al.	2003/0083747	A1	5/2003	Winterbottom et al.	
7,066,958	B2	6/2006	Ferree	2003/0100951	A1	5/2003	Serhan et al.	
7,081,120	B2	7/2006	Li et al.	2003/0125739	A1	7/2003	Bagga et al.	
7,083,651	B2	8/2006	Diaz et al.	2003/0130662	A1	7/2003	Michelson	
7,087,055	B2	8/2006	Lim et al.	2003/0135277	A1	7/2003	Bryan et al.	
7,097,648	B1	8/2006	Globerman et al.	2003/0139812	A1	7/2003	Garcia et al.	
7,115,132	B2	10/2006	Errico et al.	2003/0187448	A1	10/2003	Michelson	
7,118,580	B1	10/2006	Beyersdorff et al.	2003/0191536	A1	10/2003	Ferree	
7,147,665	B1	12/2006	Bryan et al.	2003/0195517	A1	10/2003	Michelson	
7,153,325	B2	12/2006	Kim et al.	2003/0195631	A1	10/2003	Ferree	
7,169,182	B2	1/2007	Errico et al.					
7,179,294	B2	2/2007	Eisermann et al.					

(56)

References Cited

U.S. PATENT DOCUMENTS

2003/0199982	A1	10/2003	Bryan	2006/0064169	A1	3/2006	Ferree
2003/0204261	A1	10/2003	Eisermann et al.	2006/0069439	A1	3/2006	Zucherman et al.
2003/0208271	A1	11/2003	Kuras	2006/0116768	A1	6/2006	Krueger et al.
2003/0229358	A1	12/2003	Errico et al.	2006/0142858	A1	6/2006	Colleran et al.
2003/0233145	A1	12/2003	Landry et al.	2006/0142862	A1	6/2006	Diaz et al.
2004/0002761	A1	1/2004	Rogers et al.	2006/0155378	A1	7/2006	Eckman
2004/0024407	A1	2/2004	Ralph et al.	2006/0167549	A1	7/2006	Mathys et al.
2004/0024410	A1	2/2004	Olson et al.	2006/0178744	A1	8/2006	De et al.
2004/0030391	A1	2/2004	Ferree	2006/0178746	A1	8/2006	Bartish et al.
2004/0034426	A1	2/2004	Errico et al.	2006/0195097	A1	8/2006	Evans et al.
2004/0054411	A1	3/2004	Kelly et al.	2006/0200239	A1	9/2006	Rothman et al.
2004/0059318	A1	3/2004	Zhang et al.	2006/0224241	A1	10/2006	Butler et al.
2004/0073307	A1	4/2004	Keller	2006/0235426	A1	10/2006	Lim et al.
2004/0073311	A1	4/2004	Ferree	2006/0235525	A1	10/2006	Gil et al.
2004/0073312	A1	4/2004	Eisermann et al.	2006/0235527	A1	10/2006	Buettner-Janzen et al.
2004/0093087	A1	5/2004	Ferree et al.	2006/0241641	A1	10/2006	Albans et al.
2004/0097928	A1	5/2004	Zdeblick et al.	2006/0241766	A1	10/2006	Felton et al.
2004/0098131	A1	5/2004	Bryan et al.	2006/0259144	A1	11/2006	Trieu
2004/0117021	A1	6/2004	Biedermann et al.	2006/0259146	A1	11/2006	Navarro et al.
2004/0143270	A1	7/2004	Zucherman et al.	2006/0265068	A1	11/2006	Schwab
2004/0143332	A1	7/2004	Krueger et al.	2006/0265077	A1	11/2006	Zwirkoski
2004/0143334	A1	7/2004	Ferree	2006/0287728	A1	12/2006	Mokhtar et al.
2004/0167626	A1	8/2004	Geremakis et al.	2006/0293752	A1	12/2006	Moumene et al.
2004/0176843	A1	9/2004	Zubok et al.	2006/0293753	A1	12/2006	Thramann
2004/0186569	A1	9/2004	Berry	2006/0293754	A1	12/2006	Devilliers et al.
2004/0215342	A1	10/2004	Suddaby	2007/0010826	A1	1/2007	Rhoda et al.
2004/0225295	A1	11/2004	Zubok et al.	2007/0021837	A1	1/2007	Ashman
2004/0225365	A1	11/2004	Eisermann et al.	2007/0032875	A1	2/2007	Blacklock et al.
2004/0236426	A1	11/2004	Ralph et al.	2007/0067035	A1	3/2007	Falahee
2004/0243238	A1	12/2004	Arnin et al.	2007/0067036	A1	3/2007	Hudgins et al.
2004/0254644	A1	12/2004	Taylor	2007/0073398	A1	3/2007	Fabian et al.
2005/0015094	A1	1/2005	Keller	2007/0093898	A1	4/2007	Schwab et al.
2005/0015095	A1	1/2005	Keller	2007/0100453	A1	5/2007	Parsons et al.
2005/0015152	A1	1/2005	Sweeney	2007/0100454	A1	5/2007	Burgess et al.
2005/0021145	A1	1/2005	De et al.	2007/0100456	A1	5/2007	Dooris et al.
2005/0021146	A1	1/2005	De et al.	2007/0123903	A1	5/2007	Raymond et al.
2005/0027360	A1	2/2005	Webb et al.	2007/0123904	A1	5/2007	Stad et al.
2005/0038515	A1	2/2005	Kunzler	2007/0135923	A1	6/2007	Peterman et al.
2005/0043800	A1	2/2005	Paul et al.	2007/0162133	A1	7/2007	Doubler et al.
2005/0107881	A1	5/2005	Alleyne et al.	2007/0168033	A1	7/2007	Kim et al.
2005/0113842	A1	5/2005	Bertagnoli et al.	2007/0168036	A1	7/2007	Ainsworth et al.
2005/0113928	A1	5/2005	Cragg et al.	2007/0179615	A1	8/2007	Heinz et al.
2005/0143824	A1	6/2005	Richelsof et al.	2007/0185578	A1	8/2007	O'Neil et al.
2005/0149189	A1	7/2005	Mokhtar et al.	2007/0213821	A1	9/2007	Kwak et al.
2005/0154463	A1	7/2005	Trieu	2007/0233077	A1	10/2007	Khalili
2005/0165408	A1	7/2005	Puno et al.	2007/0233247	A1	10/2007	Schwab
2005/0171604	A1	8/2005	Michalow	2007/0233248	A1	10/2007	Schwab et al.
2005/0192586	A1	9/2005	Zucherman et al.	2007/0233251	A1	10/2007	Abdou
2005/0192670	A1	9/2005	Zubok et al.	2007/0270970	A1	11/2007	Trieu
2005/0197702	A1	9/2005	Coppes et al.	2007/0282449	A1	12/2007	De et al.
2005/0197703	A1	9/2005	Diaz et al.	2007/0299521	A1	12/2007	Glenn et al.
2005/0197706	A1	9/2005	Hovorka et al.	2008/0015698	A1	1/2008	Marino et al.
2005/0216081	A1	9/2005	Taylor et al.	2008/0015701	A1	1/2008	Garcia et al.
2005/0216084	A1	9/2005	Fleischmann et al.	2008/0021557	A1	1/2008	Trieu
2005/0234553	A1	10/2005	Gordon	2008/0051900	A1	2/2008	De et al.
2005/0251260	A1*	11/2005	Gerber	2008/0051901	A1	2/2008	De et al.
			A61F 2/4425	2008/0125864	A1	5/2008	De et al.
			623/17.13	2008/0125865	A1	5/2008	Abdelgany et al.
2005/0251261	A1	11/2005	Peterman	2008/0133011	A1	6/2008	De et al.
2005/0251262	A1	11/2005	De et al.	2008/0154301	A1	6/2008	De et al.
2005/0261772	A1*	11/2005	Filippi	2008/0154382	A1	6/2008	De et al.
			A61F 2/4425	2008/0215155	A1	9/2008	De et al.
			623/17.13	2008/0221696	A1	9/2008	De et al.
2005/0267580	A1	12/2005	Suddaby	2008/0228274	A1	9/2008	De et al.
2005/0267581	A1	12/2005	Marnay et al.	2008/0228277	A1	9/2008	De et al.
2006/0004377	A1	1/2006	Keller	2008/0294259	A1	11/2008	De et al.
2006/0004453	A1	1/2006	Bartish et al.	2009/0043391	A1	2/2009	De et al.
2006/0015183	A1	1/2006	Gilbert et al.	2009/0048674	A1	2/2009	Zubok et al.
2006/0020342	A1	1/2006	Ferree et al.	2009/0048677	A1	2/2009	McLeod et al.
2006/0025862	A1	2/2006	Villiers et al.	2009/0076614	A1	3/2009	Arramon
2006/0029186	A1	2/2006	De et al.	2009/0105833	A1	4/2009	Hovda et al.
2006/0030857	A1	2/2006	De et al.	2009/0105834	A1	4/2009	Hovda et al.
2006/0030862	A1	2/2006	De et al.	2009/0105835	A1	4/2009	Hovda et al.
2006/0036325	A1	2/2006	Paul et al.	2009/0192617	A1	7/2009	Arramon et al.
2006/0041313	A1	2/2006	Allard et al.	2009/0205188	A1	8/2009	De et al.
2006/0041314	A1	2/2006	Millard	2009/0210060	A1	8/2009	De et al.
2006/0052870	A1	3/2006	Ferree	2009/0222101	A1	9/2009	De et al.
				2009/0276051	A1	11/2009	Arramon et al.

(56)

References Cited

U.S. PATENT DOCUMENTS

2009/0281629 A1* 11/2009 Roebing A61F 2/4425
623/17.16

2009/0326656 A1 12/2009 De et al.

2010/0004746 A1 1/2010 Arramon

2010/0016972 A1 1/2010 Jansen et al.

2010/0016973 A1 1/2010 De et al.

2010/0030335 A1 2/2010 Arramon

2010/0049040 A1 2/2010 De et al.

2010/0069976 A1 3/2010 De et al.

2010/0076558 A1 3/2010 De et al.

2010/0087868 A1 4/2010 Barr et al.

2010/0179419 A1 7/2010 De et al.

2011/0004313 A1 1/2011 De et al.

2011/0040386 A1* 2/2011 Kim A61F 2/4611
623/17.16

2011/0270261 A1 11/2011 Mast et al.

2011/0276141 A1* 11/2011 Caratsch A61F 2/4455
623/17.16

2013/0023990 A1* 1/2013 Zipnick A61B 17/7067
623/17.16

2013/0103153 A1* 4/2013 Blackwell A61F 2/4611
623/17.16

2013/0110240 A1* 5/2013 Hansell A61F 2/4425
623/17.16

2013/0297026 A1 11/2013 De et al.

2014/0249631 A1* 9/2014 Weiman A61F 2/4425
623/17.16

2015/0148908 A1 5/2015 Marino et al.

2017/0079809 A1 3/2017 De et al.

2019/0201210 A1* 7/2019 Besaw A61F 2/442

FOREIGN PATENT DOCUMENTS

EP 0333990 A2 9/1989

EP 0333990 A3 5/1990

EP 0560140 A1 9/1993

EP 0560141 A1 9/1993

EP 0591712 A1 4/1994

EP 0820740 A1 1/1998

EP 1142544 A1 10/2001

EP 1153582 A2 11/2001

EP 1153582 A3 11/2001

EP 1250898 A1 10/2002

EP 1306064 A1 5/2003

EP 1344493 A1 9/2003

EP 1344506 A1 9/2003

EP 1344507 A1 9/2003

EP 1344508 A1 9/2003

EP 1417940 A1 5/2004

EP 1570813 A1 9/2005

FR 2803741 A1 7/2001

JP S61122859 A 6/1986

JP S63164948 A 7/1988

WO WO-9920209 A1 4/1999

WO WO-9930651 A1 6/1999

WO WO-0004851 A1 2/2000

WO WO-0035384 A1 6/2000

WO WO-0042954 A2 7/2000

WO WO-0042954 A3 11/2000

WO WO-0101893 A1 1/2001

WO WO-0115637 A1 3/2001

WO WO-0168003 A1 9/2001

WO WO-0211650 A2 2/2002

WO WO-0211650 A3 9/2003

WO WO-2004000170 A1 12/2003

WO WO-2004000171 A1 12/2003

WO WO-2004026187 A1 4/2004

WO WO-2004041131 A2 5/2004

WO WO-2004054477 A1 7/2004

WO WO-2004066884 A1 8/2004

WO WO-2004041131 A3 9/2004

WO WO-2005004756 A2 1/2005

WO WO-2005004756 A3 5/2005

WO WO-2005053580 A1 6/2005

WO WO-2005072662 A1 8/2005

WO WO-2005112833 A1 12/2005

WO WO-2005112834 A2 12/2005

WO WO-2005112834 A3 5/2006

WO WO-2006119092 A2 11/2006

WO WO-2006119092 A3 12/2006

WO WO-2007121320 A2 10/2007

WO WO-2007121320 A3 6/2008

ZA 200603171 9/2007

OTHER PUBLICATIONS

Hellier, et al., Wear Studies for Development of an Intervertebral Disc Prosthesis. Spine, vol. 17 No. 6 Supplement pp. 86-96 (1992). International search report and written opinion dated Dec. 23, 2008 for PCT/US2008/071551.

Lee, et al. Impact Response of the Intervertebral Disc in a Finite-Element Model. Spine. 2000; 25(19):2431-2439.

Lehuc, et al. Shock Absorption in Lumber Disc Prosthesis. Journal of Spinal Disorders & Techniques. 2003; 16(4):346-351.

Notice of allowance dated Apr. 16, 2013 for U.S. Appl. No. 12/883,068.

"Notice of allowance dated May 15, 2017 for U.S. Appl. No. 15/368,437".

"Notice of allowance dated Sep. 12, 2017 for U.S. Appl. No. 15/606,587".

Notice of allowance dated Oct. 12, 2016 for U.S. Appl. No. 13/941,121.

"Office action dated Feb. 4, 2016 for U.S. Appl. No. 13/941,121".

Office action dated Mar. 12, 2012 for U.S. Appl. No. 12/883,068.

Office action dated Apr. 28, 2011 for U.S. Appl. No. 11/836,684.

Office action dated Oct. 15, 2012 for U.S. Appl. No. 12/883,068.

Office action dated Jul. 15, 2016 for U.S. Appl. No. 13/941,121.

* cited by examiner

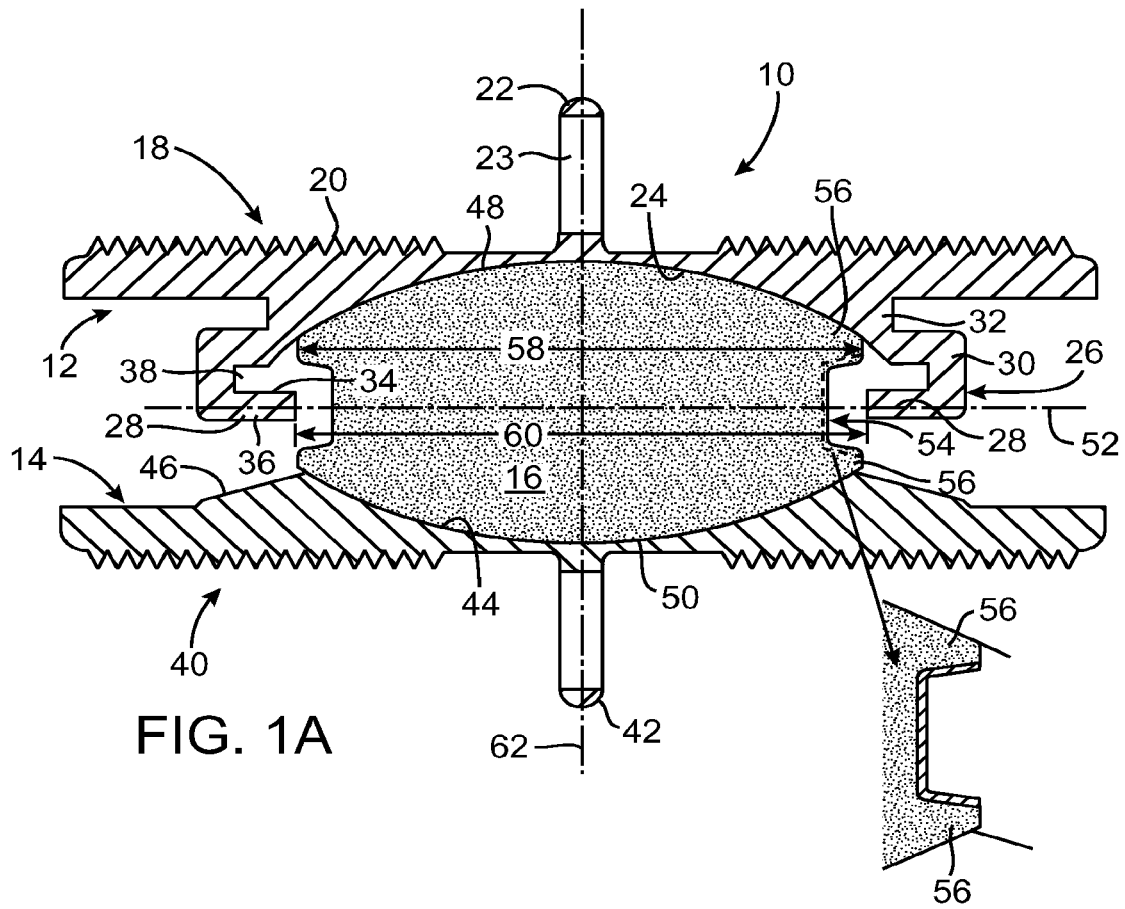

FIG. 1A

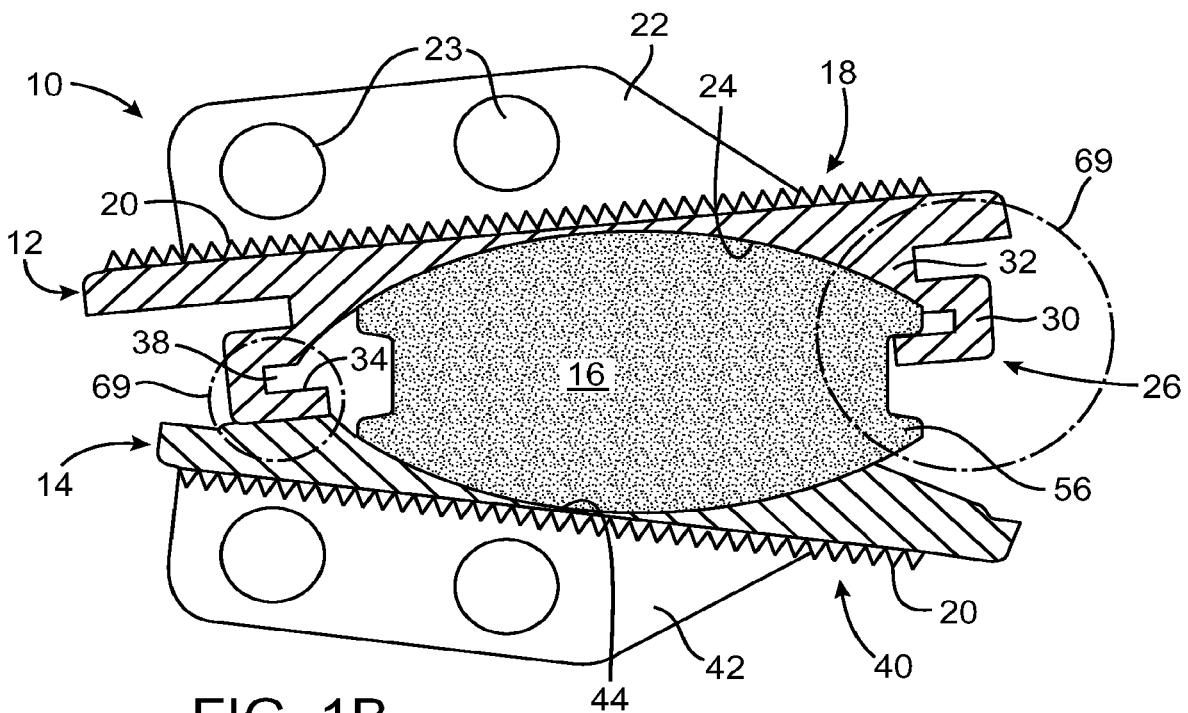

FIG. 1B

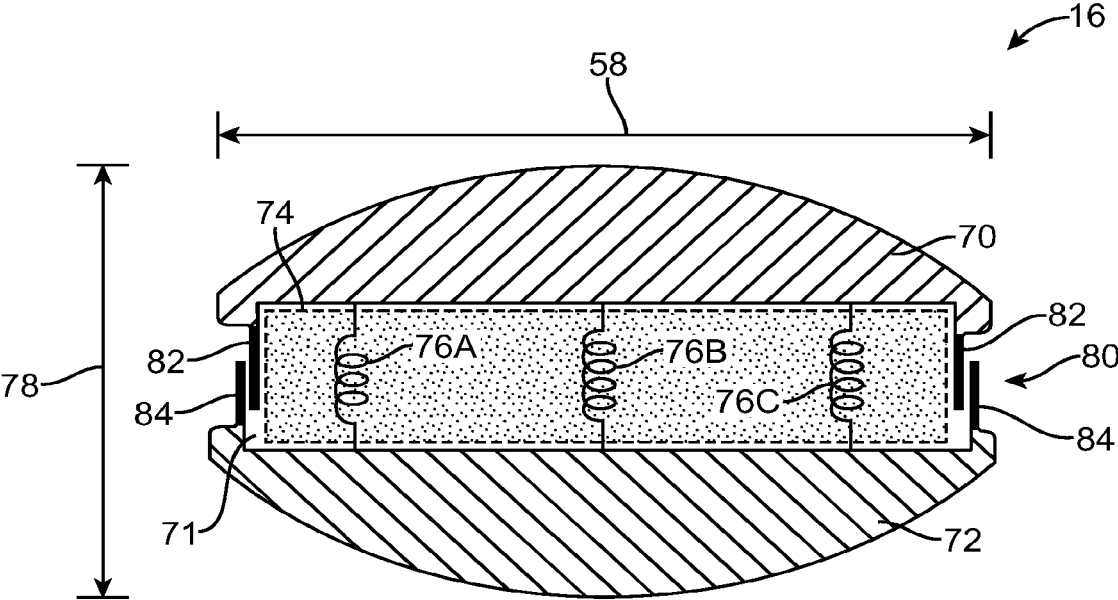

FIG. 1C

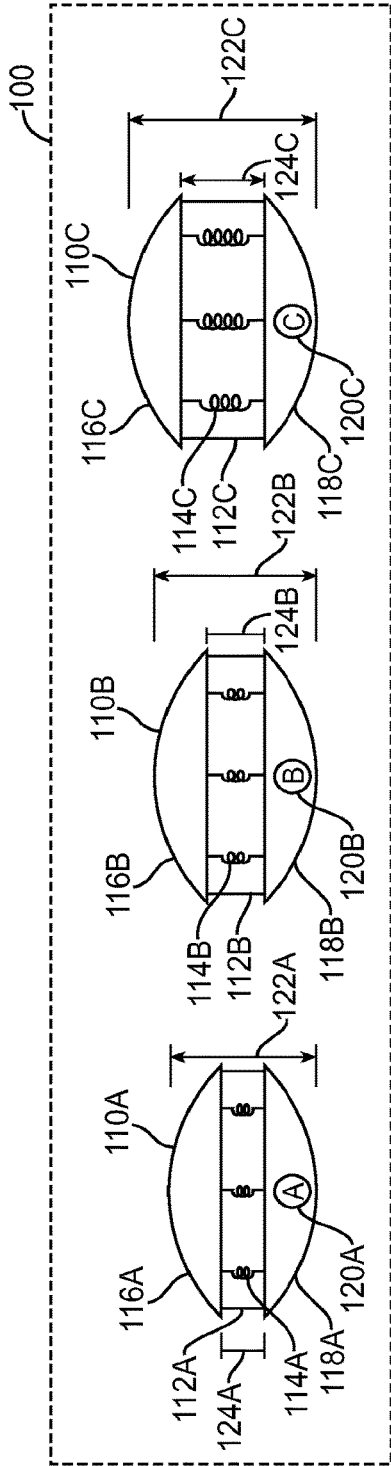

FIG. 1D

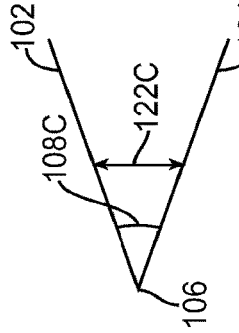

FIG. 1E

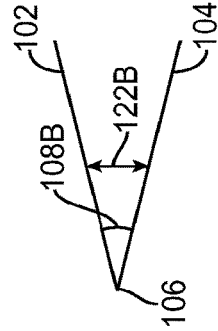

FIG. 1F

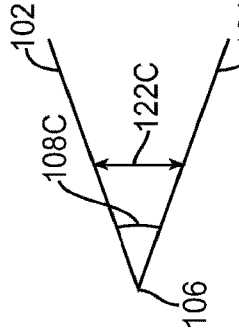

FIG. 1G

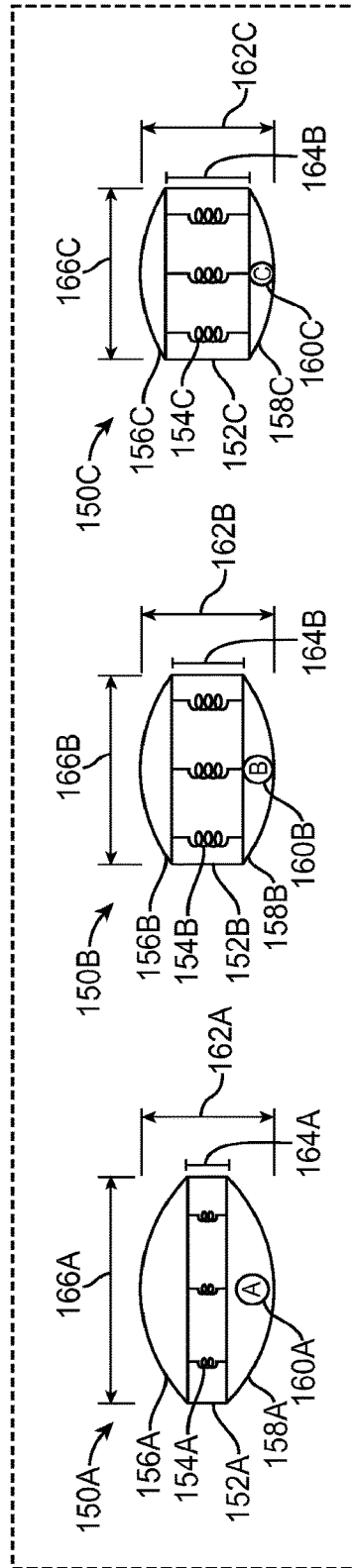

FIG. 1H

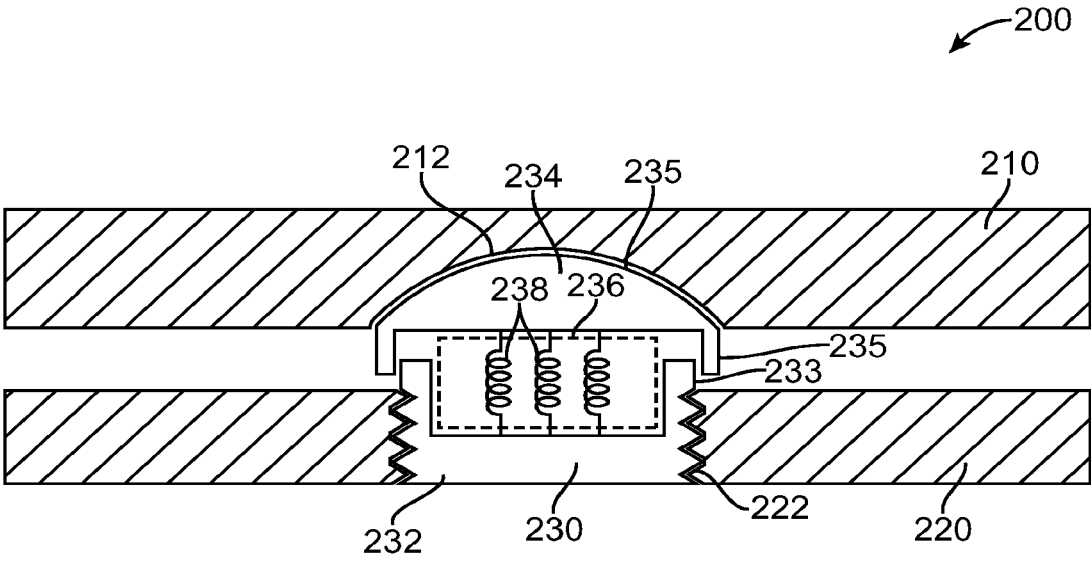
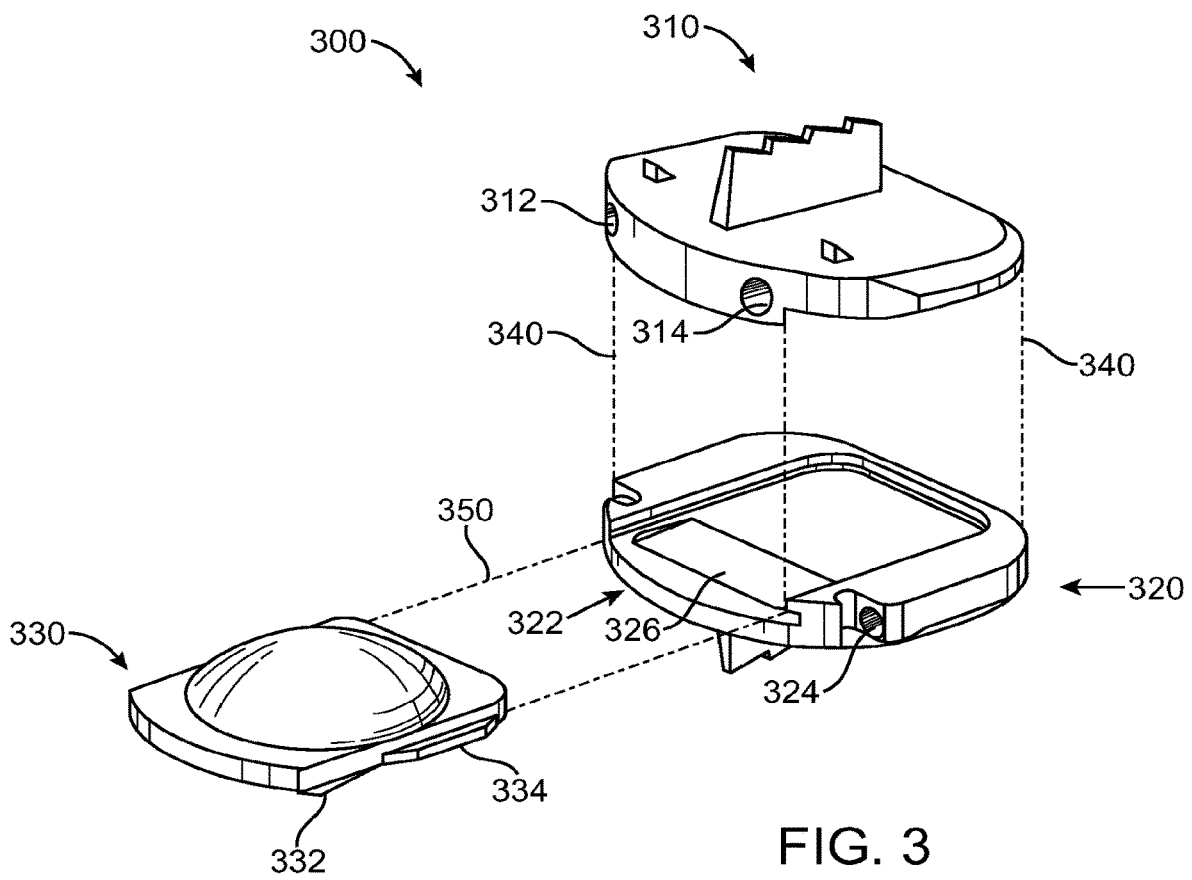

FIG. 2



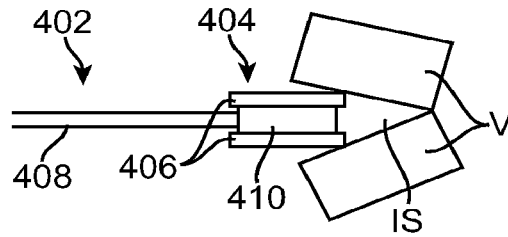

FIG. 4A

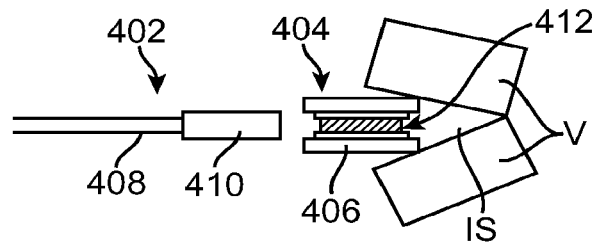

FIG. 4B

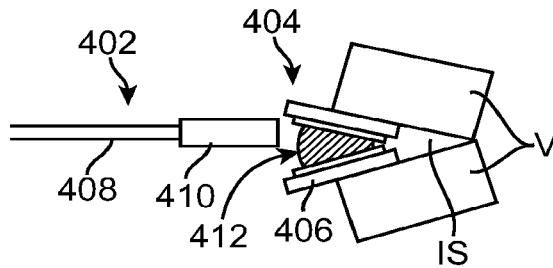

FIG. 4C

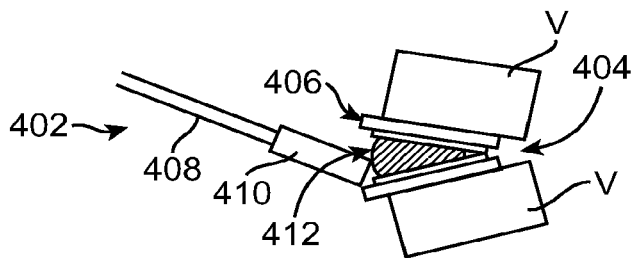

FIG. 4D

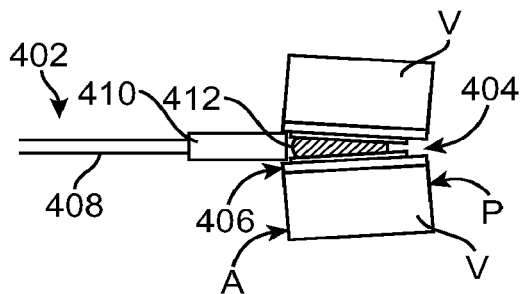

FIG. 4E

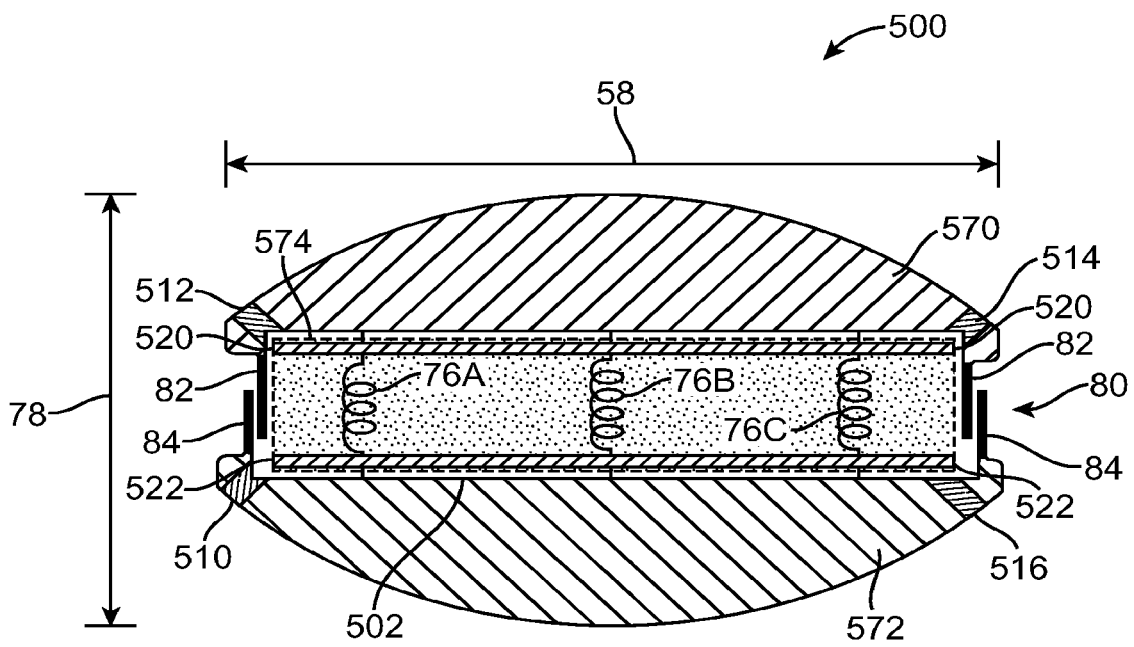

FIG. 5

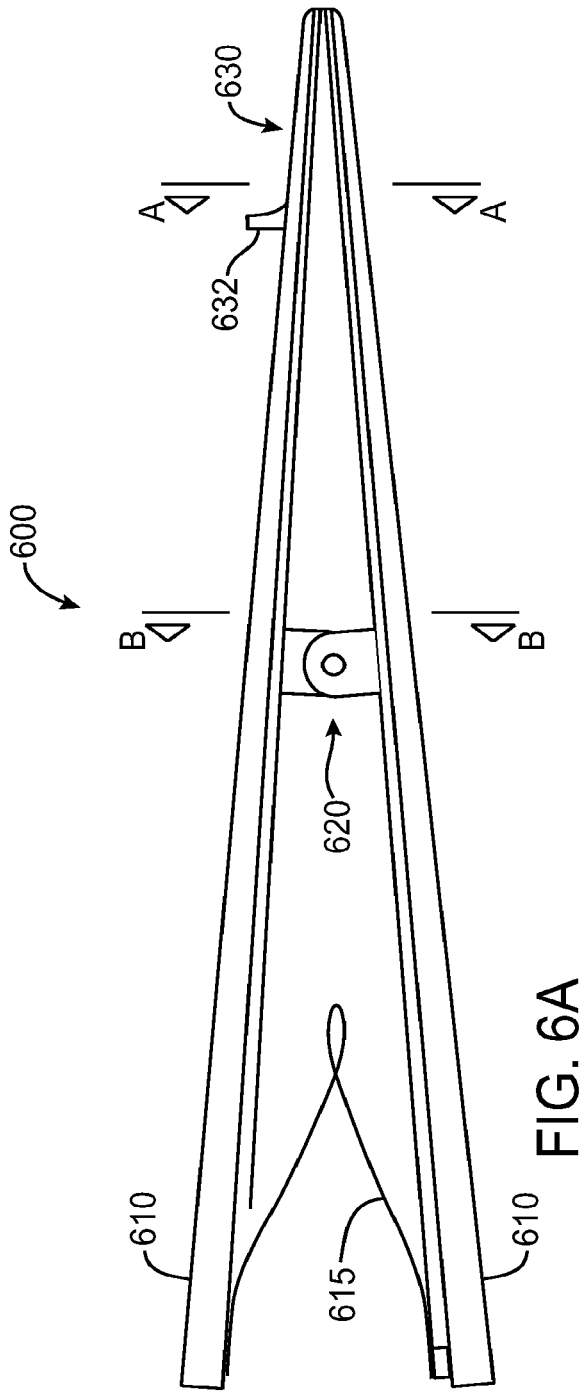

FIG. 6A

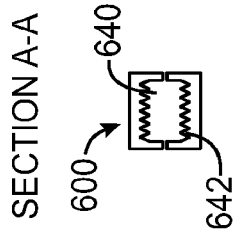

FIG. 6B

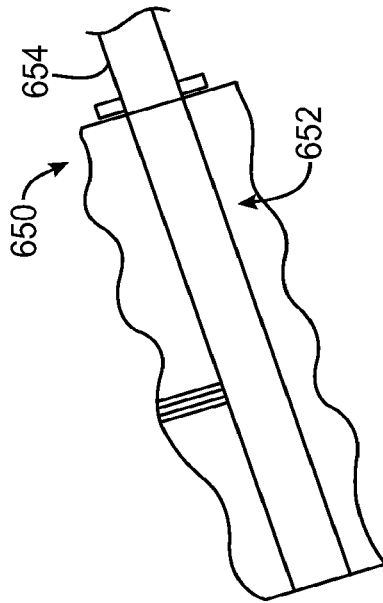

FIG. 6D

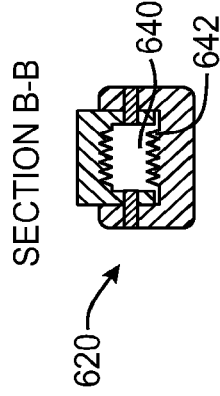

FIG. 6C

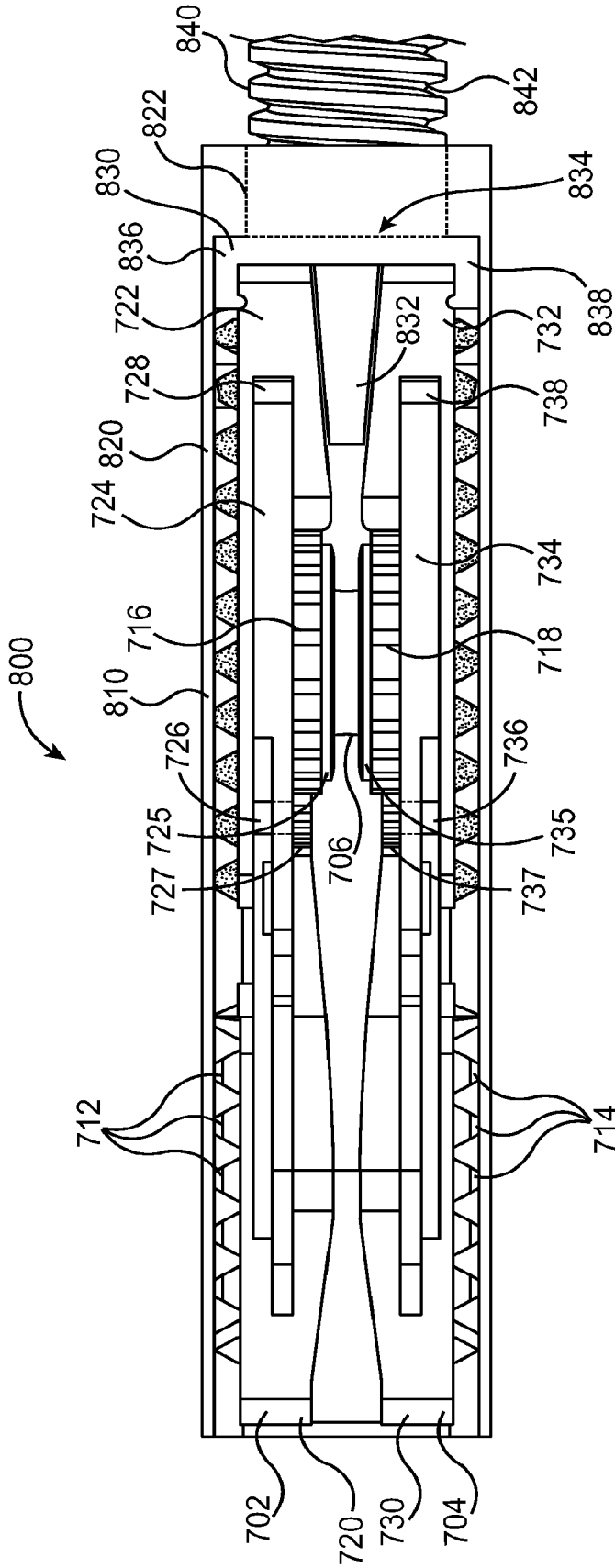

FIG. 7A

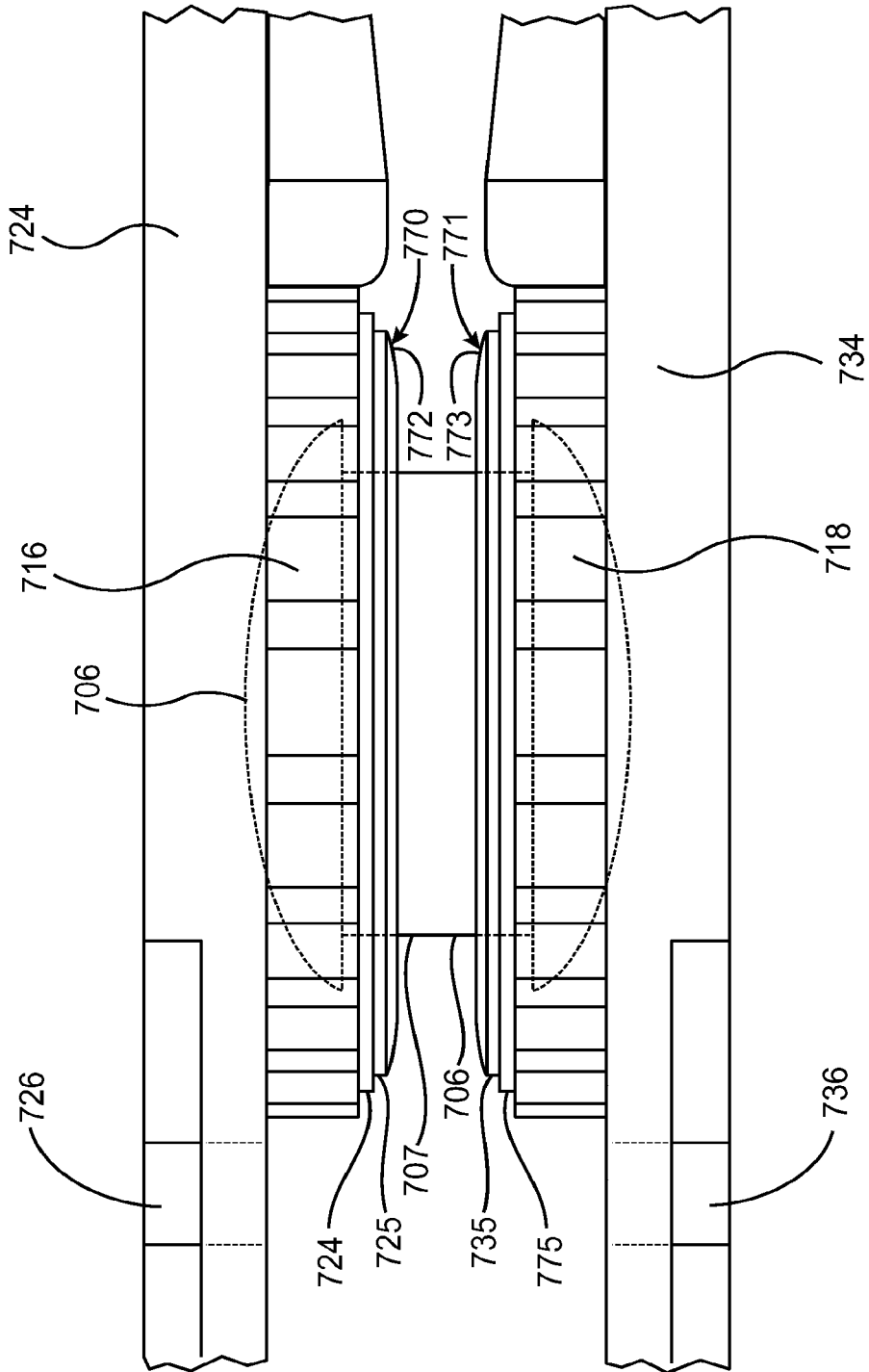

FIG. 7B

**CUSTOMIZED INTERVERTEBRAL
PROSTHETIC DISC WITH SHOCK
ABSORPTION**

CROSS-REFERENCES TO RELATED
APPLICATIONS

The present application is a continuation of U.S. patent application Ser. No. 15/795,184, filed Oct. 26, 2017, which is a continuation of U.S. patent application Ser. No. 15/606,587, filed May 26, 2017, now U.S. Pat. No. 9,827,108, which is a continuation of U.S. patent application Ser. No. 15/368,437, filed Dec. 2, 2016, now U.S. Pat. No. 9,687,355, which is a continuation of U.S. patent application Ser. No. 13/941,121, filed Jul. 12, 2013, which is a divisional of U.S. patent application Ser. No. 12/883,068, filed Sep. 15, 2010, now U.S. Pat. No. 8,506,631, which is a divisional of U.S. patent application Ser. No. 11/836,684, filed Aug. 9, 2007; the full disclosures of each are incorporated herein by reference in its entirety.

BACKGROUND OF THE INVENTION

The present invention relates to medical devices and methods. More specifically, the invention relates to intervertebral disc prostheses.

Back pain takes an enormous toll on the health and productivity of people around the world. According to the American Academy of Orthopedic Surgeons, approximately 80 percent of Americans will experience back pain at some time in their life. In just the year 2000, approximately 26 million visits were made to physicians' offices due to back problems in the United States. On any one day, it is estimated that 5% of the working population in America is disabled by back pain.

One common cause of back pain is injury, degeneration and/or dysfunction of one or more intervertebral discs. Intervertebral discs are the soft tissue structures located between each of the thirty-three vertebral bones that make up the vertebral (spinal) column. Essentially, the discs allow the vertebrae to move relative to one another. The vertebral column and discs are vital anatomical structures, in that they form a central axis that supports the head and torso, allow for movement of the back, and protect the spinal cord, which passes through the vertebrae in proximity to the discs.

Discs often become damaged due to wear and tear or acute injury. For example, discs may bulge (herniate), tear, rupture, degenerate or the like. A bulging disc may press against the spinal cord or a nerve exiting the spinal cord, causing "radicular" pain (pain in one or more extremities caused by impingement of a nerve root). Degeneration or other damage to a disc may cause a loss of "disc height," meaning that the natural space between two vertebrae decreases. Decreased disc height may cause a disc to bulge, facet loads to increase, two vertebrae to rub together in an unnatural way and/or increased pressure on certain parts of the vertebrae and/or nerve roots, thus causing pain. In general, chronic and acute damage to intervertebral discs is a common source of back related pain and loss of mobility.

When one or more damaged intervertebral discs cause a patient pain and discomfort, surgery is often required. Traditionally, surgical procedures for treating intervertebral discs have involved discectomy (partial or total removal of a disc), with or without fusion of the two vertebrae adjacent to the disc. Fusion of the two vertebrae is achieved by inserting bone graft material between the two vertebrae such that the two vertebrae and the graft material grow together.

Often times, pins, rods, screws, cages and/or the like are inserted between the vertebrae to act as support structures to hold the vertebrae and graft material in place while they permanently fuse together. Although fusion often treats the back pain, it reduces the patient's ability to move, because the back cannot bend or twist at the fused area. In addition, fusion increases stresses at adjacent levels of the spine, potentially accelerating degeneration of these discs.

In an attempt to treat disc related pain without fusion, an alternative approach has been developed, in which a movable, implantable, artificial intervertebral disc (or "disc prosthesis") is inserted between two vertebrae. A number of different intervertebral disc prostheses are currently being developed. For example, the inventors of the present invention have developed disc prostheses described in U.S. patent application Ser. Nos. 10/855,817 and 10/855,253, previously incorporated by reference. Other examples of intervertebral disc prostheses are the LINK® SB Charite disc (provided by DePuy Spine, Inc.) Mobidisk® (provided by LDR Medical (www.ldrmedical.fr)), the Bryan Cervical Disc (provided by Medtronic Sofamor Danek, Inc.), the ProDisc® or ProDisc-C® (from Synthes Stratec, Inc.), and the PCM disc (provided by Cervitech, Inc.). Although existing disc prostheses provide advantages over traditional treatment methods, improvements are ongoing.

Work in relation to the present invention suggests that current prosthesis and methodologies may be less than ideal. For example, some disc prostheses may only partially restore patient motion in some patients. Also, some disc prostheses may potentially provide more motion postoperatively than might occur naturally for an individual patient, depending on his or her individual characteristics. For example, older patients may have a smaller range of motion between vertebrae than younger patients, and a prosthesis with an appropriate range of motion for a younger patient may provide an excessive range of motion for an older patient. Younger active patients may place a greater load on a disc prosthesis, and current prostheses may be less than ideal for restoring motion between the vertebrae in a manner that fully accommodates such active patients.

Therefore, a need exists for improved intervertebral disc prostheses. Ideally, such improved prostheses would avoid at least some of the short comings of the present prostheses.

BRIEF SUMMARY OF THE INVENTION

Embodiments of the present invention provide customizable intervertebral prostheses systems and methods. The prosthesis system comprises supports that can be positioned against vertebrae and a selected resilient core that can be positioned between the supports to allow the supports to articulate. The resilient core can be selected from a plurality of cores in response to patient characteristics, such as age and/or intervertebral mobility, such that the prosthesis implanted in the patient is tailored to the needs of the patient. The plurality of cores comprise cores with different resiliencies, and one of the cores can be selected such that the upper and lower supports articulate with the desired shock absorbing resiliency and/or maximum angle of inclination when the selected core is positioned between the supports. The shock absorbing core may be compressed during insertion into the intervertebral space to minimize distraction between the vertebrae. The supports can comprise known support plates and may comprise, in some embodiments, in situ expandable supports to minimize the invasiveness of the procedure.

In a first aspect an intervertebral disc prosthesis system is provided. The system comprises a plurality of selectable cores. Each core comprises upper and lower surfaces and at least one of a resilient material or a resilient member disposed between the upper and lower surfaces to allow the upper and lower surfaces to move resiliently toward and away from each other. The system also comprises upper and lower supports that are locatable about the core. Each support comprises an outer surface which engages a vertebra and an inner surface that is shaped to contact one of the surfaces of each core. Each core of the plurality comprises a different resiliency. The upper and lower supports are adapted to articulate when one of the cores is selected and positioned between the upper and lower supports.

In many embodiments, each core is identifiable with an indicia, such that each core is selectable in response to the indicia and a patient characteristic. The indicia may comprise at least one of a color of the core, a marking on the core, a height of the core, or a width of the core. In specific embodiments, the indicia of each core corresponds to a resiliency of the core and a maximum angle of inclination between the supports when the core is positioned between the supports.

In many embodiments, each core of the plurality comprises a different dimension to limit a maximum angle of inclination between the upper and lower supports in response to the patient characteristic. The different dimension may comprise at least one of a height or a width.

In many embodiments, the upper surface of each core comprises a curved surface to slide against the inner surface of the upper support. In specific embodiments, lower surface of each core may be capable of attachment to the lower support. In some embodiments, the lower surface of each core comprises a curved surface to slide against the inner surface of the lower support.

In many embodiments, each core comprises an upper component with the upper surface disposed thereon and a lower component with the lower surface disposed thereon. The upper and lower core components of each core can be configured to slide relative to one another in response to loading when positioned between the upper and lower supports, for example loading caused by patient activity. In specific embodiments, the upper and lower components of each core are configured to slide relative to one another with telescopic motion.

In some embodiments, the upper support comprises a upper plate and the lower support comprises a lower plate.

In some embodiments, the upper support comprises an upper expandable support and the lower support comprises a lower expandable support.

In some embodiments, several cores of the plurality comprises the same height and different resiliencies, such that a maximum angle of inclination between the plates is substantially the same for the several cores.

In many embodiments, the plurality of selectable cores comprises cores with a maximum compression within a range from about $\frac{1}{3}$ mm to about 1 mm.

In another aspect, an intervertebral disc prosthesis system is provided. The intervertebral disc prosthesis system comprises a plurality of selectable cores. Each core comprises upper and lower curved surfaces. At least one of a resilient material or a resilient member is disposed between the upper and lower curved surfaces to allow the upper and lower surfaces to move resiliently toward and away from each other. The system also comprises upper and lower supports that are locatable about the core. Each support comprises an outer surface, which engages a vertebra, and an inner curved

surface shaped to slide over one of the curved surfaces of each core. Each core of the plurality comprises a different resiliency. The upper and lower supports are adapted to articulate when one of the cores is selected and positioned between the upper and lower supports.

In many embodiments, each core is identifiable with an indicia, such that each core is selectable in response to the indicia and a patient characteristic. The indicia may comprise at least one of a color of the core, a marking on the core, a height of the core, or a width of the core. In specific embodiments, the indicia of each core corresponds to a resiliency of the core and a maximum angle of inclination between the supports when the core is positioned between the supports.

In many embodiments, the at least one resilient material comprises a polymer. The at least one resilient material may comprise a hydrogel. The at least one resilient support member may be disposed within the resilient material and attached to the upper and lower curved surfaces.

In many embodiments, the at least one resilient support member comprises a plurality of springs.

In many embodiments, the upper and lower curved surfaces of the core comprise at least one of a polymer, a ceramic and a metal. The metal may comprise at least one of cobalt chrome molybdenum, titanium or stainless steel.

In another aspect, a method of assembling an intervertebral prosthesis for insertion into a patient is provided. A resilient core is selected from among a plurality of resilient cores. The core is placed between first and second supports. The core is selected in response to a resiliency of the core and a patient characteristic.

In many embodiments, the selected core is identified with an indicia and selected in response to the indicia and a patient characteristic. The indicia may comprise at least one of a color of the core, a marking on the core, a height of the core, or a width of the core. In specific embodiments, the indicia of each core corresponds to a resiliency of the core and a maximum angle of inclination between the supports when the core is positioned between the supports.

In many embodiments, the first and second supports articulate when the core is positioned between the supports. The core may comprise first and second components that slide relative to each other when the core is loaded.

In many embodiments, the core is selected in response to a maximum angle of inclination when the core is positioned between the supports.

In another aspect, a method of inserting an intervertebral prosthesis into an intervertebral space between vertebrae of a patient is provided. A shock absorbing core is compressed from an expanded profile configuration to a narrow profile configuration when the core is inserted into the intervertebral space. The shock absorbing core can articulate an upper support and a lower support when positioned between the upper support and the lower support.

In many embodiments, the upper support and the lower support are positioned in the intervertebral space, and the shock absorbing core is inserted between the upper support and the lower support while the upper support and the lower support are positioned in the intervertebral space. In specific embodiments, shock absorbing core locks into place within the upper plate or the lower plate.

In many embodiments, the core is positioned between the upper support and the lower support when the upper support and the lower support are inserted into the intervertebral space. In specific embodiments, the upper support and the lower support articulate when the upper support and the lower support are inserted into the intervertebral space.

5

In some embodiments, the shock absorbing core is compressed with an instrument when the core is inserted into the intervertebral space. The shock absorbing core can be compressed by at least about 0.5 mm when the core is inserted into the intervertebral space.

In another aspect, an intervertebral disc prosthesis is provided. The prosthesis comprises a resilient core. The core comprises an upper component with an upper surface and a lower component with a lower surface. At least one of a resilient material or a resilient member is disposed between the upper and lower components so as to allow the upper and lower components to move resiliently toward and away from each other. The upper and lower components define an inner chamber of the core. At least one channel extends from the inner chamber to an external surface of the core to allow the passage of fluid through the chamber. The prosthesis also comprises upper and lower supports locatable about the core. Each support comprises an outer surface which engages a vertebra, and an inner surface shaped to contact one of the surfaces of the core. The upper and lower supports are adapted to articulate when the core is positioned between the upper and lower supports.

In some embodiments, the at least one channel comprises at least two channels that extend from the chamber to the external surface of the core to pass fluid through the core. the at least one channel can be adapted to pump fluid out of the core when the components move toward each other and draw fluid into the core when the components move away from each other.

In another aspect, an instrument for insertion of an intervertebral disc prosthesis into an intervertebral space is provided. The instrument comprises a distractor tip that comprises a channel dimensioned to pass the prosthesis. The instrument also comprises at least one of a resilient member or a resilient material to compress the prosthesis from an expanded profile configuration to a narrow profile configuration with the distractor tip when the prosthesis slides along the channel toward the intervertebral space.

In many embodiments, a pair of handles is connected to the distractor tip. The resilient member comprises a spring connected to the handles to drive the handles apart and compress the prosthesis to the narrow profile configuration.

In another aspect, a system for insertion of an intervertebral disc prosthesis into an intervertebral space is provided. The system comprises a plurality of selectable shock absorbing intervertebral disc prosthesis cores, and an instrument. The instrument comprises a distractor tip with a channel dimensioned to pass the prosthesis. The distractor tip is capable of compressing at least one of the plurality of cores from an expanded profile configuration to a narrow profile configuration when the prosthesis slides along the channel toward the intervertebral space.

In many embodiments, the expanded profile configuration comprises an unloaded configuration of the at least one of the plurality of cores, and the narrow profile configuration comprises a maximum loaded compression of the at least one of the plurality of cores.

BRIEF DESCRIPTION OF THE DRAWINGS

FIG. 1A is a cross-sectional anterior view of an intervertebral disc prosthesis with the prosthesis plates and selected core in vertical alignment, according to embodiments of the present invention;

FIG. 1B is a side view of the prosthetic disc in FIG. 1 after sliding movement of the plates over the selected core;

6

FIG. 1C is a cross-sectional view a the selected shock absorbing cores shown in detail, according to embodiments of the present invention;

FIG. 1D shows a plurality of selectable shock absorbing cores with differing heights and differing resiliencies, according to embodiments of the present invention;

FIG. 1E schematically illustrates a first maximum angle of inclination with the first shock absorbing core of FIG. 1D positioned between endplates;

FIG. 1F schematically illustrates a second maximum angle of inclination with the second shock absorbing core of FIG. 1D positioned between the endplates;

FIG. 1G schematically illustrates a third maximum angle of inclination with the third shock absorbing core of FIG. 1D positioned between the endplates;

FIG. 1H shows a plurality of selectable shock absorbing cores with differing widths and differing resiliencies, according to embodiments of the present invention;

FIG. 2 is a cross-sectional view a prosthetic disc with a selected core attached to a lower plate, according to embodiments of the present invention;

FIG. 3 shows an intervertebral prosthesis with an upper plate, a lower plate, and a selected shock absorbing core that locks into the lower plate to provide ball and socket motion, according to embodiments of the present invention;

FIGS. 4A-4E show a method of inserting a shock absorbing prosthesis, according to embodiments of the present invention;

FIG. 5 shows a shock absorbing core with channels to allow fluid to move through the core, according to embodiments of the present invention;

FIGS. 6A to 6D show a placement instrument 600 capable of compressing the core when the implant is inserted into the intervertebral space, according to embodiments of the present invention; and

FIGS. 7A and 7B schematically illustrate details of the self-expanding intervertebral joint assembly loaded in a cartridge, in accordance with embodiments of the present invention.

DETAILED DESCRIPTION OF THE INVENTION

Various embodiments of the present invention generally provide for an intervertebral disc prosthesis having upper and lower plates disposed about a selectable core. The selectable core includes a resilient material, which allows the core to absorb forces applied to it by vertebrae. The shock absorbing cores can be used with many prosthesis and approaches to the intervertebral disc space including anterior, lateral, posterior and posterior lateral approaches. Although various embodiments of such a prosthesis are shown in the figures and described further below, the general principles of these embodiments, namely selecting a core with a force absorbing material in response to patient needs, may be applied to any of a number of other disc prostheses, such as but not limited to the LINK® SB Charite disc (provided by DePuy Spine, Inc.) Mobidisk® (provided by LDR Medical (www.ldrmedical.fr)), the Bryan Cervical Disc and Maverick Lumbar Disc (provided by Medtronic Sofamor Danek, Inc.), the ProDisc® or ProDisc-C® (from Synthes Stratec, Inc.), and the PCM disc (provided by Cervitech, Inc.). In some embodiments, the selectable core can be used with an expandable intervertebral prosthesis, as described in U.S. application Ser. No. 11/787,110, entitled

“Posterior Spinal Device and Method”, filed Apr. 12, 2007, the full disclosure of which is incorporated herein by reference.

FIGS. 1A to 1C show a prosthetic disc 10 comprising a selected shock absorbing core, according to embodiments of the present invention. Disc 10 for intervertebral insertion between two adjacent spinal vertebrae (not shown) suitably includes an upper plate 12, a lower plate 14 and a selected shock absorbing core 16 located between the plates. The upper plate 12 includes an outer surface 18 and an inner surface 24 and may be constructed from any suitable metal, alloy or combination of metals or alloys, such as but not limited to cobalt chrome molybdenum, titanium (such as grade 5 titanium), stainless steel and/or the like. In one embodiment, typically used in the lumbar spine, the upper plate 12 is constructed of cobalt chrome molybdenum, and the outer surface 18 is treated with aluminum oxide blasting followed by a titanium plasma spray. In another embodiment, typically used in the cervical spine, the upper plate 12 is constructed of titanium, the inner surface 24 is coated with titanium nitride, and the outer surface 18 is treated with aluminum oxide blasting. An alternative cervical spine embodiment includes no coating on the inner surface 24. In other cervical and lumbar disc embodiments, any other suitable metals or combinations of metals may be used. In some embodiments, it may be useful to couple two materials together to form the inner surface 24 and the outer surface 18. For example, the upper plate 12 may be made of an MRI-compatible material, such as titanium, but may include a harder material, such as cobalt chrome molybdenum, for the inner surface 24. In another embodiment, upper plate 12 may comprise a metal, and inner surface 24 may comprise a ceramic material. All combinations of materials are contemplated within the scope of the present invention. Any suitable technique may be used to couple materials together, such as snap fitting, slip fitting, lamination, interference fitting, use of adhesives, welding and/or the like. Any other suitable combination of materials and coatings may be employed in various embodiments of the invention.

In some embodiments, the outer surface 18 is planar. Oftentimes, the outer surface 18 will include one or more surface features and/or materials to enhance attachment of the prosthesis 10 to vertebral bone. For example, the outer surface 18 may be machined to have serrations 20 or other surface features for promoting adhesion of the upper plate 12 to a vertebra. In the embodiment shown, the serrations 20 extend in mutually orthogonal directions, but other geometries would also be useful. Additionally, the outer surface 18 may be provided with a rough microfinish formed by blasting with aluminum oxide microparticles or the like. In some embodiments, the outer surface may also be titanium plasma sprayed to further enhance attachment of the outer surface 18 to vertebral bone.

The outer surface 18 may also carry an upstanding, vertical fin 22 extending in an anterior-posterior direction. The fin 22 is pierced by transverse holes 23. In alternative embodiments, the fin 22 may be rotated away from the anterior-posterior axis, such as in a lateral-lateral orientation, a posterolateral-anterolateral orientation, or the like. In some embodiments, the fin 22 may extend from the surface 18 at an angle other than 90.degree. Furthermore, multiple fins 22 may be attached to the surface 18 and/or the fin 22 may have any other suitable configuration, in various embodiments. In some embodiments, such as discs 10 for cervical insertion, the fins 22, 42 may be omitted altogether.

The inner, spherically curved concave surface 24 is formed at a central (from right to left), axial position with a

circular recess 26 as illustrated. At the outer edge of the curved surface 24, the upper plate 12 carries peripheral restraining structure comprising an integral ring structure 26 including an inwardly directed rib or flange 28. The flange 28 forms part of a U-shaped member 30 joined to the major part of the plate by an annular web 32. The flange 28 has an inwardly tapering shape and defines upper and lower surfaces 34 and 36 respectively which are inclined slightly relative to the horizontal when the upper plate 12 is at the orientation seen in FIG. 1. An overhang 38 of the U-shaped member 30 has a vertical dimension that tapers inwardly as illustrated.

The lower plate 14 is similar to the upper plate 12 except for the absence of the peripheral restraining structure 26. Thus, the lower plate 14 has an outer surface 40 which is planar, serrated and microfinished like the outer surface 18 of the upper plate 12. The lower plate 14 optionally carries a fin 42 similar to the fin 22 of the upper plate. The inner surface 44 of the lower plate 14 is concavely, spherically curved with a radius of curvature matching that of the inner surface 24 of the upper plate 12. Once again, this surface may be provided with a titanium nitride or other finish.

At the outer edge of the inner curved surface 44, the lower plate 14 is provided with an inclined ledge formation 46. Alternatively, the lower plate 14 may include peripheral restraining structure analogous to the peripheral restraining structure 26 on the upper plate 12.

The selected shock absorbing core 16 is symmetrical about a central, equatorial plane 52 which bisects it laterally. (Although in other embodiments, the selected shock absorbing core 16 may be asymmetrical.) Lying on this equatorial plane is an annular recess or groove 54 which extends about the periphery of the selected shock absorbing core. The groove 54 is defined between upper and lower ribs or lips 56. When the plates 12, 14 and selected shock absorbing core 16 are assembled and in the orientation seen in FIG. 1, the flange 28 lies on the equatorial plane and directly aligned with the groove 54. The outer diameter 58 of the lips 56 is preferably very slightly larger than the diameter 60 defined by the inner edge of the flange 28. In some embodiments, the selected shock absorbing core 16 is movably fitted into the upper plate 12 via an interference fit. To form such an interference fit with a metal component of selected core 16 and metal plate 12, any suitable techniques may be used. For example, the plate 12 may be heated so that it expands, and the component of selected core 16 may be dropped into the plate 12 in the expanded state. When the plate 12 cools and contracts, the interference fit is created. In another embodiment, the upper plate 12 may be formed around the component of selected shock absorbing core 16. Alternatively, the selected shock absorbing core 16 and upper plate 12 may include complementary threads, which allow the selected shock absorbing core 16 to be screwed into the upper plate 12, where it can then freely move.

The central axis of the disc 10 (the axis passing through the centers of curvature of the curved surfaces) is indicated with the reference numeral 62. As shown in FIG. 1, the disc 10 may be symmetrical about a central anterior-posterior plane containing the axis 62. In some embodiments the axis 62 is posteriorly disposed, i.e. is located closer to the posterior limit of the disc than the anterior limit thereof.

In use, the disc 10 is surgically implanted between adjacent spinal vertebrae in place of a damaged disc. The adjacent vertebrae are forcibly separated from one another to provide the necessary space for insertion. The disc 10 is typically, though not necessarily, advanced toward the disc space from an anterolateral or anterior approach and is

inserted in a posterior direction—i.e., from anterior to posterior. The disc is inserted into place between the vertebrae with the fins **22**, **42** of the plates **12**, **14** entering slots cut in the opposing vertebral surfaces to receive them. During and/or after insertion, the vertebrae, facets, adjacent ligaments and soft tissues are allowed to move together to hold the disc in place. The serrated and microfinished surfaces **18**, **40** of the plates **12**, **14** locate against the opposing vertebrae. The serrations **20** and fins **22**, **42** provide initial stability and fixation for the disc **10**. With passage of time, enhanced by the titanium surface coating, firm connection between the plates and the vertebrae will be achieved as bone tissue grows over the serrated surface. Bone tissue growth will also take place about the fins **22**, **40** and through the transverse holes **23** therein, further enhancing the connection which is achieved.

In the assembled disc **10**, the complementary and cooperating spherical surfaces of the plates and selected shock absorbing core allow the plates to slide or articulate over the selected core through a fairly large range of angles and in all directions or degrees of freedom, including rotation about the central axis **62**. FIG. **1A** shows the disc **10** with the plates **12** and **14** and selected shock absorbing core **16** aligned vertically with one another on the axis **62**. FIG. **1B** illustrates a situation where maximum anterior flexion of the disc **10** has taken place. At this position, the upper rib **56** has entered the hollow **38** of the U-shaped member **30**, the lower surface of the rib **56** has moved into contact with the upper surface **34** of the flange **28**, the flange having moved into the groove **54**, and the lower surface **36** of the flange has moved into contact with the upper surface of the ledge formation **46**, as will be seen in the encircled areas **69**. Abutment between the various surfaces prevents further anterior flexure. The design also allows for the inner extremity of the flange **28** to abut against the base of the groove **54**, thereby limiting further relative movement between the selected core and plate. A similar configuration is achieved in the event of maximum posterior flexure of the plates **12**, **14** over the selected shock absorbing core, such as during spinal extension and/or in the event of maximum lateral flexure.

The flange **28** and the groove **54** defined between the ribs **56**, prevent separation of the selected core from the plates. In other words, the cooperation of the retaining formations ensures that the selected shock absorbing core is held captive between the plates at all times during flexure of the disc **10**.

In an alternative embodiment, the continuous annular flange **28** may be replaced by a retaining formation comprising a number of flange segments which are spaced apart circumferentially. Such an embodiment could include a single, continuous groove **54** as in the illustrated embodiment. Alternatively, a corresponding number of groove-like recesses spaced apart around the periphery of the selected core could be used, with each flange segment opposing one of the recesses. In another embodiment, the continuous flange or the plurality of flange segments could be replaced by inwardly directed pegs or pins carried by the upper plate **12**. This embodiment could include a single, continuous groove **54** or a series of circumferentially spaced recesses with each pin or peg opposing a recess.

In yet another embodiment, the retaining formation(s) can be carried by the lower plate **14** instead of the upper plate, i.e. the plates are reversed. In some embodiments, the upper (or lower) plate is formed with an inwardly facing groove, or circumferentially spaced groove segments, at the edge of its inner, curved surface, and the outer periphery of the

selected core is formed with an outwardly facing flange or with circumferentially spaced flange segments.

Referring now to FIG. **1C**, a cross-sectional view of a selected shock absorbing core **16** is shown in detail. Core **16** comprises an upper component **70** and a lower component **72**. Upper component **70** and lower component **72** define a chamber **71**. A resilient material **74** can be positioned between upper component **70** and lower component **72** within chamber **71**. Resilient material **74** may extend between from one component to the other to component, such that upper component **70** is supported with the resilient material. Resilient material **74** may comprise many known resilient materials, for example an elastomer such as siloxane. At least one resilient member can be positioned between upper component **70** and lower component **72**. The at least one resilient member may comprise many known resilient members, for example a spring **76A**, a spring **76B** and a spring **76C**. In some embodiments, resilient member **74** is positioned between the upper and lower components to provide shock absorption without the springs. In some embodiments, the at least one resilient member is positioned between the upper and lower components without the resilient material. The resilient materials and at least one resilient member may comprise resilient materials and members as described in U.S. application Ser. No. 11/051,513, entitled "Intervertebral Prosthetic Disc with Shock Absorption", filed on Feb. 4, 2005, the full disclosure of which is incorporated herein by reference.

Upper component **70** and lower component **72** are configured to slide relative to one another. Upper component **70** comprises an upper slide structure, for example an inner annular sleeve **82**. Lower component **72** comprises a lower slide structure, for example an outer annular sleeve **84**. The upper slide structure mates with the lower slide structure, such that the two slide structures permit the upper component to slide relative to the lower component, for example with a telescopic slide mechanism **80**.

In some embodiments, the sequential motion of the core parts relative to each other can change the volume chamber **71** so as to provide an inflow and outflow of bodily fluids between the sliding members of the core, such that the fluid flow provides and facilitates lubrication of the sliding members with bodily fluids.

When implanted between vertebrae, at least one of resilient material **74** or the at least one resilient member can resiliently absorb shocks transmitted vertically between upper and lower vertebrae of the patient's spinal column. This shock absorption is related to the material properties and dimensions of the resilient material and resilient members, for example Young's modulus of elasticity. In general, an increased thickness of the resilient material and/or members will increase absorbance of shocks, with more elastic, or springy compression between the vertebrae. In some embodiments, the resilient material may comprise a damping material and/or damping characteristics to improve shock absorption. For example, many resilient materials as described herein also comprise damping materials.

Selected shock absorbing core **16** comprises a height **78** and a width **58** that can be related to the shock absorbing characteristics of the core and/or prosthesis. In many embodiments, the core can absorb shocks to the vertebrae with compression along height **78**, such that height **78** can decrease with compression of the core due to forces along the spine. As the thickness of the prosthesis is related to the height of the core, in some embodiments the height of the prosthesis will change with the core, for example decrease when the core is compressed. In many embodiments, the

11

height of the prosthesis corresponds to a distance between serrated and microfinished surfaces **18**, **40** of the plates **12**, **14** that locate against the opposing vertebrae. In some embodiments, an increase of height **78** can increase shock absorption and resiliency of the core, for example with increased thickness of the shock absorbing materials and/or increased length of the resilient members, for example the resilient members such as compressible resilient springs. In some embodiments, width **58** of the selected core may also affect properties of the endplates.

Referring now to FIG. 1D, a plurality **100** of selectable shock absorbing cores is shown with differing heights and differing resiliencies, according to embodiments of the present invention. Plurality **100** comprises a first core **110A**, a second core **110B** and a third core **110C**.

First core **110A** comprises an upper component **116A** and a lower component **118A**. A resilient material **112A** is disposed between upper component **116A** and lower component **118A**. At least one resilient member **114A** extends between upper component **116A** and lower component **118A**. First core **110A** comprises a first height **122A**. Resilient material **112A** comprises a thickness **124A** that corresponds to a length of at least one resilient member **114A**. The resilience and shock absorption of first core **110A** corresponds to thickness **124A**, such that the resilience and shock absorption increase with increasing of thickness of **124A**. First core **110A** comprises an indicia, for example a marking **120A** on the lower component to identify the first core, such that first core **110A** can be identified and selected from among plurality **100**.

Second core **110B** comprises an upper component **116B** and a lower component **118B**. A resilient material **112B** is disposed between upper component **116B** and lower component **118B**. At least one resilient member **114B** extends between upper component **116B** and lower component **118B**. Second core **110B** comprises a second height **122B**. Resilient material **112B** comprises a thickness **124B** that corresponds to a length of at least one resilient member **114B**. The resilience and shock absorption of second core **110B** corresponds to thickness **124B**, such that the resilience and shock absorption increase with increasing of thickness of **124B**. Second core **110B** comprises an indicia, for example a marking **120B** on the lower component to identify the second core, such that second core **110B** can be identified and selected from among plurality **100**.

Third core **110C** comprises an upper component **116C** and a lower component **118C**. A resilient material **112C** is disposed between upper component **116C** and lower component **118C**. At least one resilient member **114C** extends between upper component **116C** and lower component **118C**. Third core **110C** comprises a third height **122C**. Resilient material **112C** comprises a thickness **124C** that corresponds to a length of at least one resilient member **114C**. The resilience and shock absorption of third core **110C** corresponds to thickness **124C**, such that the resilience and shock absorption increase with increasing thickness of **124C**. Third core **110C** comprises an indicia, for example a marking **120C** on the lower component to identify the third core, such that third core **110C** can be identified and selected from among plurality **100**.

In many embodiments, some characteristics first core **110A**, second core **110B** and third core **110C** are substantially the same, such that the cores are interchangeable. For example, a radius of curvature of the upper component of each core may be substantially the same, such that the plates articulate without point contact between the upper curve surface of the upper components. Resilient material **112A**,

12

resilient material **112B** and resilient material **112C** may comprise the substantially the same resilient material, for example an elastomer. In some embodiments, the curved surfaces of the lower components of each core may be substantially the same such that the selected core can slide over the bottom endplate.

In many embodiments, the cores may comprise predetermined characteristics that can be identified by the markings. For example, third core **110C** may comprise the most resilient core of the plurality with the most shock absorption, while first core **110A** may comprise the least resilient core of the plurality with the least shock absorption. Also, third core **110C** may comprise the core which provides the largest maximum angle of inclination between the plates of the plurality, while first core **110A** may comprise core which provides the smallest angle of inclination between the plates.

In many embodiments, each core of the plurality of core comprises an intended maximum compression under normal patient activity. In some embodiments, first core **110A** comprises a maximum compression of $\frac{1}{3}$ mm along first height **122A** with normal patient activity; second core **110B** comprises a maximum compression of $\frac{2}{3}$ mm along second height **122B** with normal patient activity; and third core **110C** comprises a maximum compression of 1 mm along third height **122C** with normal patient activity. In some embodiments, the maximum compression can be limited with stops, for example maximum travel of inner sleeve **82** relative to outer sleeve **84** such that inner sleeve **82** on upper component **70** contacts lower core component **72** to limit compression. In some embodiments, the plurality of cores may comprise a substantially incompressible core, for example a core made entirely of metal, such as cobalt chrome. In such embodiments, the range of compression provided by the plurality of cores can be from about 0 mm to about 1 mm. A core with maximum compression of substantially zero may comprises a core made entirely from metal, for example cobalt chrome.

FIG. 1E schematically illustrates a first maximum angle of inclination **108A** with the first shock absorbing core of FIG. 1D positioned between an upper endplate **102** and a lower endplate **104**. First shock absorbing core **110A** comprises first thickness **122A**. At maximum angle of inclination **108A**, upper plate **102** contacts lower plate **104** at a contact locus **106**, for example contact formations as described above. Maximum angle of inclination **108A** is determined by thickness **122A**.

FIG. 1F schematically illustrates a second maximum angle of inclination **108B** with the second shock absorbing core of FIG. 1D positioned between upper endplate **102** and lower endplate **104**. Second shock absorbing core **110B** comprises second thickness **122B**. At maximum angle of inclination **108B**, upper plate **102** contacts lower plate **104** at contact locus **106**, for example contact formations as described above. Maximum angle of inclination **108B** is determined by thickness **122B**.

FIG. 1G schematically illustrates a third maximum angle of inclination **108C** with the third shock absorbing core of FIG. 1D positioned between upper endplate **102** and lower endplate **104**. Third shock absorbing core **110C** comprises third thickness **122C**. At maximum angle of inclination **108C**, upper plate **102** contacts lower plate **104** at contact locus **106**, for example contact formations as described above. Maximum angle of inclination **108C** is determined by thickness **122C**.

In some embodiments, the plurality of cores may comprise a constant height among the cores such that the maximum angle of inclination remains constant, while the

shock absorption varies. In such embodiments, the thickness of the resilient material and/or thickness of the at least one resilient member differ among the cores of the plurality, while thicknesses of the upper and lower components differ so as to compensate for the different thicknesses of the resilient material and/or thickness of the at least one resilient member. Thus, the thicknesses of the cores among the plurality remain constant.

Referring now FIG. 1H a plurality 140 of selectable shock absorbing cores of constant height is shown with differing widths and differing resiliencies. Plurality 140 comprises a first core 150A, a second core 150B and a third core 150C.

First core 150A comprises an upper component 156A and a lower component 158A. A resilient material 152A is disposed between upper component 156A and lower component 158A. At least one resilient member 154A extends between upper component 156A and lower component 158A. First core 150A comprises a first height 162A and a first dimension across 166A, for example a diameter. Resilient material 152A comprises a thickness 164A that corresponds to a length of at least one resilient member 154A. The resilience and shock absorption of first core 160A corresponds to thickness 164A, such that the resilience and shock absorption increase with increasing of thickness 164A. First core 150A comprises an indicia, for example a marking 160A on the lower component to identify the first core, such that first core 150A can be identified and selected from among plurality 140.

Second core 150B comprises an upper component 156B and a lower component 158B. A resilient material 152B is disposed between upper component 156B and lower component 158B. At least one resilient member 154B extends between upper component 156B and lower component 158B. Second core 150B comprises a second height 162B and a second dimension across 166B, for example a diameter. Resilient material 152B comprises a thickness 164B that corresponds to a length of at least one resilient member 154B. The resilience and shock absorption of second core 160B corresponds to thickness 164B, such that the resilience and shock absorption increase with increasing of thickness 164B. Second core 150B comprises an indicia, for example a marking 160B on the lower component to identify the second core, such that second core 150B can be identified and selected from among plurality 140.

Third core 150C comprises an upper component 156C and a lower component 158C. A resilient material 152C is disposed between upper component 156C and lower component 158C. At least one resilient member 154C extends between upper component 156C and lower component 158C. Third core 150C comprises a third height 162C and a third dimension across 166C, for example a diameter. Resilient material 152C comprises a thickness 164C that corresponds to a length of at least one resilient member 154C. The resilience and shock absorption of third core 160C corresponds to thickness 164C, such that the resilience and shock absorption increase with increasing of thickness 164C. Third core 150C comprises an indicia, for example a marking 160C on the lower component to identify the second core, such that third core 150C can be identified and selected from among plurality 140.

The height of several cores of the plurality is substantially the same, such that the maximum angle of inclination between the plates is substantially the same for each of the several cores. In some embodiments, first height 162A, second height 162B and third height 162C are substantially the same, such that the maximum angle of inclination of the plates is substantially the same.

The each core of the plurality can be identified in many ways. In some embodiments, the core may comprise an indicia that comprises at least one of a color of the core, a marking on the core, a height of the core or a width of the core. The indicia may be located on the upper component of the core, or the lower component of the core.

The resilient material may comprise many known materials and may comprise at least one resilient material. In some embodiments, the at least one resilient material comprises a polymer. The at least one resilient material may comprise a hydrogel. The at least one resilient support member may be disposed within the resilient material and attached to the upper and lower components comprising the upper and lower curved surfaces.

In many embodiments, the upper and lower components and the curved surfaces formed thereon comprise at least one a polymer, a ceramic or a metal. The metal can comprise at least one of cobalt chrome molybdenum, titanium or stainless steel.

Referring now FIG. 2, a cross-sectional view is shown of a prosthetic disc 200 with a selected shock absorbing core 230 attached to a lower plate 220. Selected shock absorbing core can be selected from a plurality of cores, for example as described above. Prosthetic disc 200 comprises an upper plate 210. Selected shock absorbing core 230 is positioned between the upper plate and the lower plate. Selected shock absorbing core 230 comprises a lower component 232 and an upper component 234. Core 230 comprises a resilient material between upper component 234 and lower component 232. At least one resilient member, for example coils 238 is shown between upper component 234 and lower component 232. Lower component 232 comprises a lower slide structure 233, for example an annular inner sleeve. Upper component 234 comprises an upper slide structure, for example an outer annular sleeve 235. The upper and slide structures comprise a sliding structure, for example a sliding telescopic joint, such that the selected core and resiliently absorb shocks to the prosthesis when positioned in the intervertebral space.

Lower plate 220 can be attached to selected shock absorbing core 230 in many known ways. For example, the selected shock absorbing core can be attached to lower plate by locking the selected core into the lower plate with a detent. Lower plate 220 comprises threads 222 to attach the selected shock absorbing core to the lower plate, for example in the operating room before the prosthesis is inserted into the intervertebral space.

In some embodiments, the shock absorbing core can be inserted between the intervertebral plates after the plates have been inverted into the intervertebral space, as described in U.S. Pat. No. 6,936,071, the full disclosure of which is incorporated herein by reference. The core can be compressed to a low profile configuration when the core is inserted between the plates to minimize distraction of the vertebrae when the core is inserted between the plates. Once the core is locked into position, the core can provide two piece ball and socket motion and shock absorption.

Shock absorbing core 230 comprises an upper curved spherical surface 235. Upper plate 210 comprises a lower curved spherical surface 212. Upper curved spherical surface 235 and lower curved spherical surface 212 each comprises a radius of curvature. The radius of curvature of the upper curved spherical surface 235 and lower curved spherical surface 212 are substantially the same, such that the upper and lower curved surfaces form a ball and socket joint, as described in U.S. Pat. No. 6,740,118, the full disclosure of which is incorporated by reference. In some

embodiments, the selected shock absorbing core comprises and indicia to identify the core, for example a letter etched in upper curved spherical surface 235.

FIG. 3 shows an intervertebral prosthesis 300 with an upper plate 310, a lower plate 320, and a selected shock absorbing core 330 that locks into the lower plate to provide ball and socket motion. Selected shock absorbing core 330 comprises a core selected from a plurality of shock absorbing cores as described above. Upper plate 310 comprises a channel 312 and a channel 314, for example as described in U.S. Pat. No. 6,936,071, the full disclosure of which is incorporated by reference. Lower plate 320 comprises a channel 322 sized to receive core 330. Lower plate 320 comprises a channel 324, and an indentation 326. Lower plate 320 may comprise a second channel similar to channel 324 that is disposed on the lower plate equidistant from the midline of the lower plate and opposite the midline. Selected shock absorbing core 330 comprises a flange 334 and a detent 332.

The upper plate 310 and lower plate 320 are sized to nest together when inserted into the intervertebral space, as indicated by lines 340. Once the upper and lower plates are positioned together in the intervertebral space, selected shock absorbing core 330 can be slid between upper plate 310 and lower plate 320 as indicated by lines 350. Channel 322 receives the selected shock absorbing core and flange 334. When the selected shock absorbing core is positioned in the lower plate, detent 332 extends into indentation 326 so as to lock the selected shock absorbing core into position in lower plate 320.

Channel 312, channel 314 and channel 324 are sized to receive prongs of an insertion tool, for example as describe in U.S. Pat. No. 5,314,477, the full disclosure of which is incorporated herein by reference. In some embodiments, the channels on the upper and lower plate receive an instrument that presses the upper and lower plates together so as to compress core 330 and minimize distraction when the core is inserted between the upper and lower plates while the plates are position in the intervertebral space.

Referring now to FIGS. 4A-4E a method is shown for inserting an intervertebral disc prosthesis 404 comprising a selected shock absorbing shock absorbing core 412, according to embodiments of the present invention. Prosthesis 402 is inserted into an intervertebral space IS between two adjacent vertebrae V with a resilient shock absorbing core that can compress during insertion into the disc space so as to minimize distraction. The method involves selecting a shock absorbing core, as described above, and inserting the disc prosthesis 404 partway into the space IS while the prosthesis 404 is constrained (FIG. 4A), for example as described in U.S. application Ser. No. 10/913,780, entitled "Methods and Apparatus for Invertebral Disc Prosthesis Insertion", the full disclosure of which is incorporated herein by reference. To insert the prosthesis 404 partway under constraint, an insertion device 402 may be used. Such an insertion device 402 may suitably include a grasping member 410 coupled with an elongate shaft 408. At an end opposite the grasping member 410 (not shown), the insertion device 402 may include a handle, an actuator to control the grasping member 410 and/or any other suitable features.

The prosthesis 404 may be inserted as far into the intervertebral space IS under constraint as is desired. In some embodiments, for example, the prosthesis 404 is inserted under constraint approximately one-third of the way into the space IS. In other embodiments, the prosthesis 404

may be inserted less than one-third of the way, closer to one-half of the way, or any other suitable distance into the space IS.

As shown in FIG. 4B, once the prosthesis 404 is inserted partway under constraint, the insertion device 402 may be removed, thus releasing the prosthesis 404 from constraint. From this point forward, the endplates 406 of the prosthesis 404 are free to move about the prosthesis shock absorbing core 412. Examples of such a prosthesis 404 with endplates 406 and selected shock absorbing core 412 are described above.

Referring now to FIGS. 4C-4E, in some embodiments the insertion device 402 may be used to push the unconstrained prosthesis 404 farther into the intervertebral space. In some embodiments, one or more separate pusher devices may be used in addition to or instead of the insertion device 402 for pushing the prosthesis 104 farther into the space IS. FIGS. 4C and 4D show that the grasping member 410 of the insertion device 402 can be adapted to push individually against the upper (FIG. 4C) and lower (FIG. 4D) endplates 406. As shown in FIG. 4E, the grasping member 410 may also be adapted to push simultaneously against the upper and lower endplates 406, thus pushing the prosthesis 404 as a unit farther into the intervertebral space IS.

By inserting the prosthesis 404 farther into the space IS while it is unconstrained and compressing the shock absorbing core, thus allowing the endplates 406 to articulate about the shock absorbing core 412 and come closer together, the method reduces the need for increasing the height of the intervertebral space IS with distraction of the vertebrae V away from each other. Because the endplates 406 are free to articulate and can compress the shock absorbing core 416 to move the plates together, the prosthesis 404 is better able to conform to the intervertebral space IS, thus reducing trauma to the vertebrae V and also limiting trauma to surrounding structures caused by over-distraction.

The unconstrained prosthesis 404 may be inserted as far into the intervertebral space IS as is desired. In some embodiments, for example, the prosthesis 404 is pushed far enough into the space IS so that a center of rotation of the prosthesis 404 is closer to a posterior edge P (FIG. 4E) of the vertebrae V than to an anterior edge A of the vertebrae V. In alternative embodiments, any other suitable insertion distance or depth may be used. Once a desired amount of insertion is achieved, the insertion device 402 is removed and the prosthesis 404 is in place between the two adjacent vertebrae V.

In various embodiments, the method just described may include fewer steps or additional steps. For example, in one embodiment, a spreader device is inserted between the two vertebrae V to spread them apart before inserting the constrained prosthesis 404. An example of such a spacing device is described in PCT Patent Application No. 2004/000171, the full disclosure of which is incorporated by reference. In such embodiments, the insertion device 402 can be sized to fit between opposing jaws of the spreader device, such that the jaws can compress the shock absorbing core so as to minimize distraction. When the prosthesis 404 is partially inserted, the spreader device is removed from the intervertebral space IS, and the prosthesis 404 is released from constraint and inserted the rest of the way into the space IS. Also in some embodiments, a midline indicator device may be used to facilitate the location of a midline on one or both of the two adjacent vertebrae V. An example of such a midline indicator device is described in PCT Patent Application No. 2004/000170, the full disclosure of which is incorporated herein by reference. In some embodiments, the

midline indicator can be used before the disc prosthesis 404 is inserted. These and other steps or features may be included in various embodiments of the method without departing from the scope of the invention.

FIG. 5 shows a shock absorbing core 500 with channels to allow fluid to move through the core, according to 5
embodiments of the present invention. Many components of core 500 are similar to core 16 shown above. Core 500 comprises a channel 510, a channel 512, a channel 514 and a channel 516. An upper component 570 and lower component 572 of core 500 define a chamber 502. Resilient material 574 and resilient member 76A, resilient member 76B and resilient member 76C can be disposed between the upper and lower components within chamber 502. Resilient material 574 may comprise an upper channel 520 and a lower channel 522 to permit drainage from resilient material 574 and/or the chamber. In many, embodiments, core 500 comprises channel 510, channel 512, channel 514 and channel 516 without resilient material 574. Channel 510, channel 512, channel 514 and channel 516 extend from chamber 502 to an external surface of core 500 to permit fluid to drain from the core and/or pass through the core.

The channels in the upper and lower components and resilient material in core 500 permit fluid to pass through the core while the patient is stationary and can pump fluid through the core during patient activity. Work in relation to 10
embodiments of the present invention suggests that static accumulation of bodily fluids in the core may occur. By passing fluid through the core, bacteria build up due to static enclosed fluids may be avoided. When upper component 570 moves toward lower component 572 a volume of chamber 502 decreases so as to drive fluid, for example bodily fluid from chamber 502. When the upper component 520 moves away from lower component 572, the volume of chamber 502 increases so as to draw fluid into the chamber. As an active person will resiliently compress and expand core 500 with activity, core 500 can pump fluid in and out of the core by moving the upper and lower components toward and away from each other with patient movement. In many 15
embodiments, the channels are large enough to enable fluid flow, and small enough to inhibit tissue in growth that may compromise the shock absorbing motion of the core. The number of channels in the upper and lower components and/or resilient material can be selected so as to enable fluid flow and not weaken the core structures.

FIGS. 6A to 6D show a placement instrument 600 capable of compressing the core when the implant is inserted into the intervertebral space, according to embodiments of the present invention. The placement instrument can be inserted posteriorly through the canal and/or foramen so as to engage the bony endplates near the disc space, as described in U.S. application Ser. No. 11/787,110, entitled "Posterior Spinal Device and Method", filed Apr. 12, 2007, the full disclosure of which has previously been incorporated herein by reference. In many embodiments, the placement instrument is inserted after two minimally invasive Wiltse incisions and/or dissections and a discectomy that uses a posterior parallel distractor. Placement instrument 600 comprises a distractor with a distractor tip 630 that can be inserted at least partially into the intervertebral space. Instrument 600 comprises a stop to limit penetration of distractor tip 630. Instrument 600 comprises handles 610 to distract the adjacent vertebrae. Instrument 600 comprises a hinge 620 that opens distractor tip 630 upon inward motion of handles 610.

Instrument 600 comprises a compression spring 615 that presses handles 610 apart, so as to oppose inward motion of the handles. By forcing handles 610 apart, compression

spring 615 can close distractor tip 630 so as to compress the core to a narrow profile configuration.

Instrument 600 is adapted to pass the prostheses in an elongate narrow profile configuration into the intervertebral space. Distractor tip 630 comprises a channel 640 with grooves 642 formed therein. Channel 640 is dimensioned to pass the prosthesis in an elongate narrow profile configuration. Grooves 642 are dimensioned and spaced to receive anchors on the external surfaces of the support components, for example pyramidal components as described above. In some embodiments, the anchors may comprise elongate pyramidal anchors and or elongate keels or flanges and the grooves adapted to pass the elongate anchors with the groove aligned with the elongate anchor. In many embodiments, channel 640 is sized to distract the vertebrae with distractor tip 630 while the elongate prosthesis slides down channel 640. Near hinge 620, channel 640 can be sized to pass the prosthesis with a sliding fit.

Instrument 600 comprises an insertion tool 650 to advance the prosthesis along channel 640 so as to advance the prosthesis into the intervertebral space. Insertion tool 650 comprises a shaft 654 and a handle 652. Handle 652 is connected to shaft 654. In many embodiments handle 652 comprises a grub screw, and handle 652 and shaft 654 comprise strong materials such that handle 652 can be hammered so as to drive the prosthesis distally into the intervertebral space and distract the vertebrae with separation of distal tip 630. Compression spring 1651 can expand to force handles 610 open and close distractor tip 630 so as to press the upper and lower supports of the prosthesis together and compress the selected shock absorbing core. This compression of the shock absorbing core can reduce the height of the prosthesis and reduce distraction of the intervertebral space and/or surrounding tissues when the implant is inserted into the intervertebral space.

The selectable shock absorbing cores and insertion tool may comprise a system for narrow profile insertion of the prosthesis into the intervertebral space so as to minimize distraction. The compression spring can compress the shock absorbing prosthesis to a narrow profile configuration. Although a compression spring is shown, many springs and/or resilient members and/or materials can be used to compress the prosthesis to a narrow profile configuration, for example resilient materials and members similar to those used in the core as described above. In many embodiments, the selected core provides maximum compression within a range from about $\frac{1}{3}$ mm to about 1 mm during patient activity, and the narrow profile configuration of the core comprises a maximum compression of the core, for example $\frac{1}{3}$ mm, $\frac{2}{3}$ mm or 1 mm, depending on the core as described above. In many embodiments, an expanded configuration of the core comprises an unloaded configuration of the core. In many embodiments, the resilient member and/or material is connected to the distractor tips so as to compress the selected shock absorbing prosthesis and/or core to the narrow profile configuration, for example with maximum compression of the core as described above, when the core is positioned in the channel for insertion into the patient.

FIGS. 7A and 7B schematically illustrate a selectable shock absorbing core and details of a self-expanding intervertebral joint assembly loaded in a cartridge as described in U.S. application Ser. No. 11/787,110, entitled "Posterior Spinal Device and Method", filed Apr. 12, 2007, the full disclosure of which has previously been incorporated herein by reference. A system comprising shock absorbing cores, as described above, can be provided to the

physician. The physician can select the core from among a plurality of cores as described above.

Outer cartridge casing **820** extends over at least a portion of intervertebral joint assembly to permit advancement of the joint assembly into at least a portion of the intervertebral space while the joint assembly is substantially covered with outer cartridge casing **820**. Outer cartridge casing **820** covers pyramidal anchors **712** and pyramidal anchors **714**. Distal component **720** of upper support **702** and distal component **730** of lower support **704** are located near an opening in outer cartridge casing **820**. Inner cartridge part **830** includes a wedge **832**, upper flange **836** and lower flange **838**. The upper and lower flanges include inner opposing surfaces, and the inner surface of each flange opposes one of the wedge surfaces to clamp the components of the upper and lower supports in a parallel configuration. Inner cartridge part **830** is connected to shaft **840**.

Self expanding intervertebral joint assembly **700** includes structures to permit articulation between upper support **702** and lower support **704** to restore motion between the vertebrae. Upper support **702** has a protruding structure **725** which extends from middle component **724** and has a concave surface feature formed therein, as shown herein above, which mates the upper surface of shock absorbing biconvex core **706**. Lower support **704** has a protruding structure **735** which extends from middle component **734** and has a concave surface feature formed therein, which mates the lower surface of shock absorbing biconvex core **706**. In an alternate embodiment, the features of the upper and lower support are in direct contact and mate to provide articulation. For example, the upper support can have a protrusion with a convex surface, and the lower support can have a protrusion with a concave surface, in which the two surfaces mate to form a load bearing articulate joint.

Protruding structure **725** and protruding structure **726** can also include structures to retain the shock absorbing biconvex core and upper and lower retention ring gears, respectively. In many embodiments, shock absorbing core **607** comprises an annular channel **707** around the periphery of the shock absorbing core. Annular channel **707** is sized to receive retention ring structures of the upper and lower plates, so as to retain the shock absorbing core between the plates.

Protruding structure **725** can include a retention ring, rim or annular flange as described above such as an annular flange **770** that projects radially inward toward shock absorbing biconvex core **706** to retain shock absorbing biconvex core **706**. Protruding structure **735** can include a radially inwardly projecting retention ring, rim or annular flange such as an annular flange **771** that extends toward shock absorbing biconvex core **706** to retain shock absorbing biconvex core **706**. Annular flange **770** has a bevel **772** formed thereon to limit motion between the upper and lower supports. Annular flange **771** has a bevel **773** formed thereon to limit motion between the upper and lower supports. Bevel **772** and bevel **773** can be inclined so as to avoid point loading when the upper and lower supports are at the maximum angle of inclination. Annular flange **770** and annular flange **771** can extend into annular channel **701** to retain the core. In some embodiments, the plates as described above include an upper retention ring and a lower retention ring with each of the upper and lower retention rings shaped to engage an annular channel of the core so as to retain the core between the plates.

Retention ring gear **716** can have an annular shape formed to mate with protruding structure **725**. Protruding structure **725** can include an outer circular surface that mates with an

inner surface of inner annular surface of retention ring gear **716**. Retention ring gear **716** can rotate around protruding structure **725**. In addition to inwardly protruding annular flange **770** that retains shock absorbing biconvex core **706**, protruding structure **725** can include a retention element **775** such as an outwardly protruding annular flange and/or C-ring clip to retain retention ring gear **716**.

Retention ring gear **718** can also have an annular shape formed to mate with protruding structure **735**. Protruding structure **735** can include an outer circular surface that mates with an inner annular surface of retention ring gear **718**. Retention ring gear **718** can rotate around protruding structure **735**. In addition to an inwardly protruding annular flange that retains shock absorbing biconvex core **706**, protruding structure **735** can include an outwardly protruding retention element **775** such as an annular flange and/or C-ring clip to retain retention ring gear **718**.

Implant **700** can include structures that pivot while the upper and lower supports are formed. A pivot gear **727** can engage upper retention ring gear **716**. Pivot gear **727** is connected to joint **726** so that rotation of pivot gear **727** rotates pivot joint **726** to rotate distal component **720**. A pivot joint **728** connects proximal component **722** to middle component **724** of upper support **702**. Rotation about pivot joint **728** pivots middle component **724** toward the deployed position. A pivot gear **737** can engage lower retention ring gear **718**. Pivot gear **737** is connected to pivot joint **736** so that rotation of pivot gear **737** rotates pivot joint **736** to rotate distal component **704** toward the deployed position. A pivot joint **738** connects proximal component **732** to middle component **734** of lower support **704**. Rotation about pivot joint **738** pivots middle component **734** toward the deployed position.

Wedge **832**, upper flange **836** and lower flange **838** restrain motion of the joint assembly during deployment by clamping the joint assembly while the joint assembly is advanced. Wedge **832** is positioned between upper support **702** and lower support **704**. Wedge **832** and upper flange **836** engage proximal component **722** of upper support **702**. Wedge **832** and lower flange **838** engage proximal component **732** of lower support **704**. Inwardly facing projections are provided on the ends of the upper flange **836** and lower flange **838**. Advancement of inner cartridge part **830** advances wedge **832**, upper, the upper and lower supports distally to engage gears of the support.

In many embodiments, the shock absorbing core can be compressed with an instrument during insertion to allow for a lower profile during insertion. For example, casing **810** of cartridge **800** can be sized to compress the core during insertion so as to lower the profile of the core. The core can also be compressed during insertion through a tube, sleeve, or the like such that core assumes a low profile compressed configuration during insertion so as to minimize the invasiveness of the procedure, for example with a posterior lateral Wiltse approach as described in U.S. application Ser. No. 11/787,110, entitled "Posterior Spinal Device and Method", filed Apr. 12, 2007, the full disclosure of which has previously been incorporated herein by reference. In some embodiments, the core and/or prosthesis can be compressed with forceps while inserted into the intervertebral space.

While the exemplary embodiments have been described in some detail, by way of example and for clarity of understanding, those of skill in the art will recognize that a variety of modifications, adaptations, and changes may be employed. Hence, the scope of the present invention should be limited solely by the appended claims.

What is claimed is:

1. An intervertebral disc prosthesis system comprising:
 - a plurality of selectable cores, each core comprising, upper and lower surfaces, each of the selectable cores having differing heights between the upper and lower surfaces and identified with an indicia indicating the height of the core;
 - first and second plates locatable about the core, each plate comprising, an outer surface configured to engage a vertebra, and an inner surface shaped to contact one of the outer surfaces of each core;
 - a retaining formation which holds the core captive between the first and second plates, wherein the retaining formation includes an inwardly facing groove at an edge of the inner surface of the first plate and an outwardly facing flange on an outer periphery of the plurality of selectable cores;
 wherein the first and second plates are adapted to articulate with respect to one another and the core when one of the cores is selected and positioned between the first and second plates.
2. The system of claim 1, wherein the indicia comprises at least one of a color of the core or a marking on the core.
3. The system of claim 1, wherein the lower surface of each core is capable of attachment to the first plate.
4. The system of claim 1, wherein the outwardly facing flange comprises a plurality of circumferentially spaced flange segments.
5. The system of claim 1, wherein the inwardly facing groove comprise circumferentially spaced groove segments.
6. The system of claim 1, wherein the selectable cores each include at least one spherical bearing surface.
7. The system of claim 1, wherein the selectable cores are formed of a resilient material comprising a polymer.
8. The system of claim 1, wherein the outer surface of the first and second plates each have a fin extending in an anterior-posterior direction.
9. A method of assembling an intervertebral prosthesis, the method comprising:
 - selecting a core from among a plurality of selectable cores comprising, upper and lower surfaces, each of the selectable cores having differing heights between the upper and lower surfaces and each of the selectable cores having an outer periphery provided with an outwardly facing flange;

- placing the selected core between first and second plates; holding the selected core captive between the first and second plates with a retaining formation which includes the outwardly facing flange on the periphery of the selected core and an inwardly facing groove of the first plate; and
- allowing the first and second plates to articulate with respect to one another when the selected core is positioned between the first and second plates.
10. The method of claim 9, wherein the plurality of selectable cores are identified with an indicia indicating a height of the core and the selected core is selected in response to the indicia.
11. The method of claim 10, wherein the indicia comprises at least one of a color of the core or a marking on the core.
12. The method of claim 9, wherein selected core locks into place within the first plate or the second plate.
13. The method of claim 9, wherein the selected core is positioned between the first and second plates when the first plate and the second plate are inserted into the intervertebral space.
14. The method of claim 9, wherein the first plate and the second plate articulate with respect to the selected core when the first plate and the second plate are inserted into an intervertebral space.
15. The method of claim 9, wherein the outwardly facing flange comprises a plurality of circumferentially spaced flange segments.
16. The method of claim 9, wherein the inwardly facing groove comprises circumferentially spaced groove segments.
17. The method of claim 9, wherein the selectable cores each include at least one spherical bearing surface.
18. The method of claim 9, wherein the selectable cores have a substantially circular perimeter.
19. The method of claim 9, wherein the intervertebral prosthesis including the first and second plates and the selected core are connected to an insertion device with a grasping member.
20. The method of claim 19, wherein the grasping member is configured to allow the intervertebral prosthesis to be inserted under constraint.

* * * * *