



US007910392B2

(12) **United States Patent**
Gibson et al.

(10) **Patent No.:** **US 7,910,392 B2**
(45) **Date of Patent:** **Mar. 22, 2011**

(54) **METHOD AND SYSTEM FOR ASSEMBLING A SOLAR CELL PACKAGE**

3,575,721 A 4/1971 Mann
3,597,050 A 8/1971 Plumat
3,641,354 A 2/1972 De Ment

(75) Inventors: **Kevin R. Gibson**, Redwood City, CA (US); **Ramon Rosal Reglos**, San Ramon, CA (US)

(Continued)

FOREIGN PATENT DOCUMENTS

(73) Assignee: **Solaria Corporation**, Fremont, CA (US)

AU 743826 B2 2/2002
(Continued)

(*) Notice: Subject to any disclaimer, the term of this patent is extended or adjusted under 35 U.S.C. 154(b) by 211 days.

OTHER PUBLICATIONS

"Emissivity Values for Common Materials". <http://www.infrared-thermography.com/material-1.htm> retrieved on Apr. 2, 2010.*

(21) Appl. No.: **12/060,801**

(Continued)

(22) Filed: **Apr. 1, 2008**

(65) **Prior Publication Data**

US 2008/0236664 A1 Oct. 2, 2008

Related U.S. Application Data

(60) Provisional application No. 60/909,691, filed on Apr. 2, 2007, provisional application No. 60/909,692, filed on Apr. 2, 2007.

(51) **Int. Cl.**

B29C 65/16 (2006.01)
H01L 31/0203 (2006.01)
H01L 31/0232 (2006.01)

(52) **U.S. Cl.** **438/65**; 438/66; 136/246; 136/251; 156/272.8; 257/433

(58) **Field of Classification Search** 136/243-265; 438/57-98, 24, 48, 118; 257/753, 754, 782, 257/433; 156/272.8

See application file for complete search history.

(56) **References Cited**

U.S. PATENT DOCUMENTS

2,470,618 A 5/1949 Holden
3,330,700 A 7/1967 Sequeira et al.
3,446,676 A 5/1969 Goldsmith et al.

(57) **ABSTRACT**

Method and system for assembling a solar cell package. According to an embodiment, the present invention provides a method for fabricating solar cells for a solar panel. The method includes providing a first substrate member comprising a plurality of photovoltaic strips thereon. The method also includes providing an optical elastomer material overlying a portion of the first substrate member. The method further includes aligning a second substrate member comprising a plurality of optical concentrating elements thereon such that at least one of the optical concentrating elements being operably coupled to at least one of the plurality of photovoltaic strips, the second substrate member comprising an aperture surface region and an exit surface region. In addition, the method includes coupling the first substrate member to the second substrate member to form an interface region along a first peripheral region of the first substrate member and along a second peripheral region of the second substrate member.

25 Claims, 11 Drawing Sheets

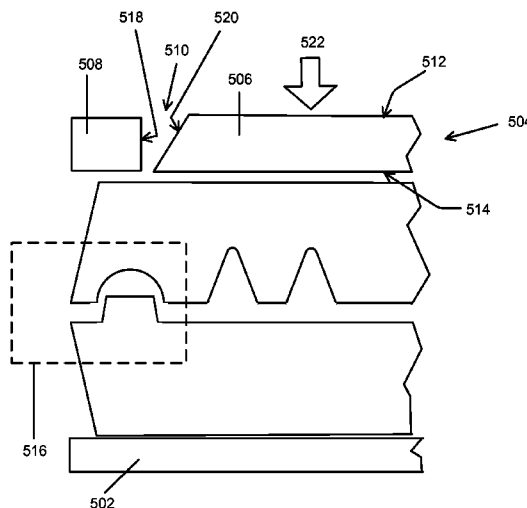

U.S. PATENT DOCUMENTS					
3,700,714 A	10/1972	Hamilton et al.	5,466,301 A	11/1995	Hammerbacher et al.
3,819,417 A	6/1974	Haynos	5,468,304 A	11/1995	Hammerbacher et al.
3,849,880 A	11/1974	Haynos	5,478,402 A *	12/1995	Hanoka 136/251
3,874,931 A	4/1975	Haynos	5,498,297 A	3/1996	O'Neill et al.
3,951,633 A	4/1976	Danihel	5,508,205 A	4/1996	Dominquez et al.
3,993,505 A	11/1976	Pack	5,517,339 A	5/1996	Riccobono et al.
3,999,283 A	12/1976	Dean et al.	5,529,054 A	6/1996	Shoen
4,029,519 A	6/1977	Schertz et al.	5,542,409 A	8/1996	Sampayo
4,056,405 A	11/1977	Varadi	5,564,411 A	10/1996	Gercis
4,091,798 A	5/1978	Selcuk	5,616,186 A	4/1997	Fraas et al.
4,097,308 A	6/1978	Klein et al.	5,660,644 A	8/1997	Clemens
4,106,952 A	8/1978	Kravitz	5,665,607 A	9/1997	Kawama et al.
4,118,249 A	10/1978	Graven et al.	5,707,459 A	1/1998	Itoyama et al.
4,122,833 A	10/1978	Selcuk	5,709,833 A	1/1998	Simone
4,143,234 A	3/1979	Johnson et al.	5,735,966 A	4/1998	Luch
4,166,917 A	9/1979	Dorfeld et al.	5,782,993 A	7/1998	Ponewash
4,170,507 A	10/1979	Keeling et al.	5,787,878 A	8/1998	Ratliff, Jr.
4,174,978 A	11/1979	Lidorenko et al.	5,790,304 A	8/1998	Sanders et al.
4,193,820 A	3/1980	Thomas	5,840,147 A	11/1998	Grimm
4,203,646 A	5/1980	Desso	5,846,444 A	12/1998	Edwards et al.
4,239,555 A	12/1980	Scharlack et al.	5,851,309 A	12/1998	Kousa
4,257,821 A	3/1981	Kelly et al.	5,865,905 A	2/1999	Clemens
4,291,191 A	9/1981	Dahlberg	5,877,874 A	3/1999	Rosenberg
4,293,192 A	10/1981	Bronstein	5,882,434 A	3/1999	Horne
4,295,463 A	10/1981	Citron	5,915,170 A	6/1999	Raab et al.
4,333,447 A	6/1982	Lemrow et al.	5,919,316 A	7/1999	Bogorad et al.
4,355,478 A *	10/1982	Armstrong 140/92.1	5,936,777 A	8/1999	Dempewolf
4,361,136 A	11/1982	Huang	5,959,787 A	9/1999	Fairbanks
4,362,903 A	12/1982	Eichelberger et al.	5,964,216 A	10/1999	Hoffschmidt et al.
4,404,422 A	9/1983	Green et al.	6,008,449 A	12/1999	Cole
4,440,153 A	4/1984	Melchior	6,020,553 A	2/2000	Yogev
4,449,514 A	5/1984	Selcuk	6,034,322 A	3/2000	Pollard
4,454,371 A	6/1984	Folino	6,049,035 A	4/2000	Tsuri et al.
4,457,297 A	7/1984	Sobczak et al.	6,057,505 A	5/2000	Ortabasi
4,463,749 A	8/1984	Sobczak et al.	6,074,614 A	6/2000	Hafeman et al.
4,495,360 A	1/1985	Anthony	6,084,175 A	7/2000	Perry et al.
4,511,618 A	4/1985	Duchene et al.	6,091,017 A	7/2000	Stern
4,562,637 A *	1/1986	Kushima et al. 219/121.64	6,091,020 A	7/2000	Fairbanks et al.
4,571,812 A	2/1986	Gee	6,092,392 A	7/2000	Verlinden et al.
4,589,191 A	5/1986	Green et al.	6,093,757 A	7/2000	Pern
4,638,110 A	1/1987	Erbert	6,107,564 A	8/2000	Aguilera et al.
4,663,562 A	5/1987	Miller et al.	6,118,067 A	9/2000	Lashley et al.
4,668,314 A	5/1987	Endoh et al.	6,134,784 A	10/2000	Carrie et al.
4,680,074 A	7/1987	Schmitz et al.	6,150,602 A	11/2000	Campbell
4,683,154 A	7/1987	Benson et al.	6,167,724 B1	1/2001	Pozivil
4,691,994 A	9/1987	Tveryanovich	6,242,685 B1	6/2001	Mizukami et al.
4,692,557 A	9/1987	Samuelson et al.	6,252,155 B1	6/2001	Ortabasi
4,697,042 A	9/1987	Schilling	6,264,510 B1	7/2001	Onizuka
4,711,972 A	12/1987	O'Neill	6,274,402 B1	8/2001	Verlinden et al.
4,830,038 A	5/1989	Anderson et al.	6,274,860 B1	8/2001	Rosenberg
4,848,319 A	7/1989	Appeldorn	6,293,803 B1	9/2001	Rust et al.
4,863,224 A	9/1989	Tveryanovich	6,294,723 B2	9/2001	Uematsu et al.
4,953,577 A	9/1990	Marshall	6,309,901 B1	10/2001	Tahon et al.
4,964,713 A	10/1990	Goetzberger	6,315,575 B1	11/2001	Kajimoto
4,999,059 A	3/1991	Bagno	6,320,116 B1	11/2001	Hanoka
5,006,179 A	4/1991	Gaddy et al.	6,323,415 B1	11/2001	Uematsu et al.
5,011,544 A	4/1991	Gaddy et al.	6,333,457 B1	12/2001	Mulligan et al.
5,043,198 A	8/1991	Maruyama et al.	6,333,458 B1	12/2001	Forrest et al.
5,080,725 A	1/1992	Green et al.	6,337,283 B1	1/2002	Verlinden et al.
5,118,361 A	6/1992	Fraas et al.	6,359,209 B1	3/2002	Glenn et al.
5,153,780 A	10/1992	Jorgensen et al.	6,365,823 B1	4/2002	Kondo
5,158,618 A	10/1992	Rubin et al.	6,387,726 B1	5/2002	Verlinden et al.
5,167,724 A	12/1992	Chiang	6,395,972 B1	5/2002	Tran et al.
5,174,275 A	12/1992	Holland	6,423,568 B1	7/2002	Verlinden et al.
5,180,442 A	1/1993	Elias	6,429,037 B1	8/2002	Wenham et al.
5,180,888 A	1/1993	Sugiyama et al.	6,433,913 B1	8/2002	Bauer et al.
5,224,978 A	7/1993	Hermant et al.	6,437,236 B2	8/2002	Watanabe et al.
5,240,510 A	8/1993	Goldade et al.	6,440,769 B2	8/2002	Peumans et al.
5,245,985 A	9/1993	Holland	6,441,297 B1	8/2002	Keller
5,261,970 A	11/1993	Landis et al.	6,479,744 B1	11/2002	Tsuzuki et al.
5,344,496 A	9/1994	Stern et al.	6,528,716 B2	3/2003	Collette et al.
5,356,488 A	10/1994	Hezel	6,528,718 B2	3/2003	Yoda et al.
5,365,920 A	11/1994	Lechner	6,609,836 B1	8/2003	Antonelli et al.
5,395,070 A	3/1995	Wilk	6,612,705 B1	9/2003	Davidson et al.
5,409,520 A	4/1995	Mori et al.	6,617,505 B2	9/2003	Shimada
5,436,725 A	7/1995	Ledger	6,619,282 B1	9/2003	Murtha
5,449,626 A	9/1995	Hezel	6,620,995 B2	9/2003	Vasylyev et al.
5,460,659 A	10/1995	Krut	6,639,733 B2	10/2003	Minano et al.
			6,641,868 B2	11/2003	Abe et al.

6,666,207 B1	12/2003	Arkas et al.	2008/0236664 A1	10/2008	Gibson et al.
6,676,263 B2	1/2004	Winston	2008/0241479 A1	10/2008	Nghiem et al.
6,700,054 B2	3/2004	Cherney et al.	2008/0314438 A1	12/2008	Tran et al.
6,700,055 B2	3/2004	Barone			
6,758,609 B2	7/2004	Fathi et al.			
6,761,598 B2	7/2004	Onizuka et al.			
6,804,062 B2	10/2004	Atwater et al.			
6,809,250 B2	10/2004	Gerson			
6,815,070 B1	11/2004	Burkle et al.			
6,822,157 B2	11/2004	Fujioka			
6,825,052 B2	11/2004	Eldridge et al.			
6,829,908 B2	12/2004	Bowden et al.			
6,843,573 B2	1/2005	Rabinowitz et al.			
6,849,797 B2	2/2005	Koyanagi et al.			
6,903,261 B2	6/2005	Habraken et al.			
6,958,868 B1	10/2005	Pender			
7,019,207 B2	3/2006	Harneit et al.			
7,055,519 B2	6/2006	Litwin			
7,071,134 B2	7/2006	Koyama et al.			
7,144,598 B2	12/2006	Moravec et al.			
7,156,666 B2	1/2007	Mann			
7,190,110 B2	3/2007	Tokai et al.			
7,250,209 B2	7/2007	Shibahara et al.			
7,282,240 B1	10/2007	Jackman et al.			
7,309,831 B2	12/2007	Yamada et al.			
7,423,083 B2	9/2008	Kawaguchi et al.			
7,595,543 B2	9/2009	Weber et al.			
2002/0007845 A1	1/2002	Collette et al.			
2002/0018308 A1	2/2002	Winston			
2002/0075579 A1	6/2002	Vasylyev et al.			
2002/0139414 A1	10/2002	Vasylyev et al.			
2003/0015233 A1	1/2003	Barone			
2003/0016539 A1	1/2003	Minano et al.			
2003/0021897 A1	1/2003	Abe et al.			
2003/0037569 A1	2/2003	Arbab et al.			
2003/0037814 A1	2/2003	Cohen et al.			
2003/0074976 A1	4/2003	Ahmad			
2003/0081333 A1	5/2003	Winston			
2003/0095340 A1	5/2003	Atwater et al.			
2003/0121542 A1	7/2003	Harneit et al.			
2003/0156337 A1	8/2003	Davidson et al.			
2003/0201007 A1	10/2003	Fraas et al.			
2003/0228114 A1	12/2003	Fathi et al.			
2003/0228417 A1	12/2003	Nishikawa et al.			
2004/0004216 A1	1/2004	Eldridge et al.			
2004/0016454 A1	1/2004	Murphy et al.			
2004/0021964 A1	2/2004	Rabinowitz et al.			
2004/0084077 A1	5/2004	Aylaian			
2004/0092668 A1	5/2004	Kawaguchi et al.			
2004/0097012 A1	5/2004	Weber et al.			
2004/0108813 A1	6/2004	Tokai et al.			
2004/0123895 A1	7/2004	Kardauskas et al.			
2004/0134531 A1	7/2004	Habraken et al.			
2004/0194820 A1	10/2004	Barone			
2004/0229394 A1	11/2004	Yamada			
2004/0243364 A1	12/2004	Wendelin et al.			
2004/0246605 A1	12/2004	Stiles et al.			
2005/0070059 A1	3/2005	Blakers et al.			
2005/0081908 A1	4/2005	Stewart			
2005/0081909 A1	4/2005	Paull			
2005/0087294 A1	4/2005	Rabinowitz			
2005/0133082 A1	6/2005	Konold et al.			
2006/0054211 A1	3/2006	Meyers et al.			
2006/0099833 A1	5/2006	Mann			
2006/0105897 A1	5/2006	Kasuga et al.			
2006/0207646 A1	9/2006	Terreau et al.			
2006/0235717 A1	10/2006	Sharma et al.			
2006/0266406 A1	11/2006	Faust et al.			
2006/0272698 A1	12/2006	Durvasula			
2006/0283495 A1	12/2006	Gibson			
2007/0056626 A1	3/2007	Funcelli			
2007/0095386 A1	5/2007	Gibson			
2007/0153354 A1	7/2007	Duston et al.			
2007/0251568 A1	11/2007	Maeda			
2008/0060696 A1	3/2008	Ho et al.			
2008/0197376 A1	8/2008	Bert et al.			
2008/0236650 A1	10/2008	Gibson et al.			
2008/0236655 A1	10/2008	Baldwin et al.			

FOREIGN PATENT DOCUMENTS

AU	220348	A5	6/2002
AU	3902270	A4	5/2003
AU	2349175	AA	6/2003
CA	2432300	AA	6/2002
CA	2467112	AA	6/2003
DE	298 23 351	U1	6/1999
EP	0029721		6/1981
EP	461124	B1	5/1995
EP	784870		4/1996
EP	657948	A3	6/1997
EP	1 030 376	A1	8/2000
EP	1174342	A1	1/2002
EP	1261039	A1	11/2002
EP	1131586	B1	3/2003
EP	1342259	A1	9/2003
EP	1112597	B1	3/2004
EP	1 427 025	A2	6/2004
EP	1461834	A1	9/2004
EP	1 630 875	A2	3/2006
EP	1 732 141	A1	12/2006
GB	1187969		4/1970
JP	61044741	A	3/1986
JP	09018031		1/1997
JP	10104547	A2	4/1998
WO	WO 9118420	A1	11/1991
WO	WO 9406046	A1	3/1994
WO	WO 9506330	A1	3/1995
WO	WO 9533220	A1	12/1995
WO	WO 9623115	A1	8/1996
WO	WO 9624954	A1	8/1996
WO	WO 9803823	A1	1/1998
WO	WO 9832164	A1	7/1998
WO	WO 9905462	A1	2/1999
WO	WO 0074147	A1	12/2000
WO	WO 0079593	A1	12/2000
WO	WO 0151962	A2	7/2001
WO	WO 0155650	A3	8/2001
WO	WO 0190661	A3	11/2001
WO	WO 0208058	A1	1/2002
WO	WO 0245143	A1	6/2002
WO	WO 02075225	A2	9/2002
WO	WO 0155650	C2	10/2002
WO	WO 02095838	A1	11/2002
WO	WO 03019083	A1	3/2003
WO	WO 03022578	A1	3/2003
WO	WO 03047004	A1	6/2003
WO	WO 03049201	A1	6/2003
WO	WO 03107078	A2	12/2003
WO	WO 2004100252	A1	11/2004
WO	WO 2006/015430	A1	2/2006
WO	WO 2006/089540	A2	8/2006
WO	WO 2006/123194	A1	11/2006
WO	WO 2006/128417	A1	12/2006
WO	WO 2006/133126	A2	12/2006
WO	WO 2007/036199	A2	4/2007

OTHER PUBLICATIONS

International Search Report and Written Opinion of PCT Application No. PCT/US 08/59167, date of mailing Dec. 8, 2008, 11 pages total.

Andreev et al., "Concentrator PV Modules of "All-Glass" Design With Modified Structure," Paper 3P-C3-72 presented at WCPEC-3, Osaka Japan; May 11-18, 2003; 4 pages.

ACLAR Fluoropolymer Film by SPI Supplies, <http://web.archive.org/web/20021022180352/http://www.2spi.com/catalog/photo/acalr-film.shtml>, 3 pages, 2000.

Boedeker Plastics, Inc.: Acrylic Polymethyl-MethAcrylate PMMA datasheet, <http://www.boedeker.com/acryl.html>; May 7, 1999; pp. 1-2.

Breeze, A.J., et al., "Improving power efficiencies in polymer—polymer blend photovoltaics", Solar Energy Materials & Solar Cells, 83, 2004, pp. 263-271.

"3M Glass Bubbles", Product Catalogue for 3M Energy and Advance Materials, Feb. 18, 2009, pp. 1-3.

- King et al. "Photovoltaic Module Performance and Durability Following Long-Term Field Exposure", Prog. Photovol: Res. and Appl., vol. 8, No. 2, p. 241-256 (May 23, 2000).
- Marayuma, T., et al. "Wedge-shaped light concentrator using total internal reflection", Solar Energy Materials & Solar Cells, 57, (1999), pp. 75-83.
- Nitto Denko, Web page: <http://www.nitto.com/product/datasheet/037/index.html> as updated on Apr. 18, 2005 from Internet Archive, 2 pages.
- Pern et al, "Photothermal Stability of an E-Beam Pre-Crosslinked EVA Encapsulant and Its Performance Degradation on a-Si Submodules", NREL/CP-520-31026, Oct. 2001, Lakewood, Colorado, 4 pages.
- Petrie, "Additives in Radiation (EB/UV) Cured Adhesive Formulations" www.specialchem4adhesives.com, Oct. 14, 2002, 6 pages.
- Photovoltaic/Solar Panel Laminations; MADICO, http://www.madico.com/specialty_pv.asp; Jun. 11, 2007; pp. 1-2.
- Solar Electricity Beginner Notes, Sun Wind Solar; Jan. 8, 2004; http://www.sunwindsolar.com/a_lessons/solar_beginner_notes.html; pp. 1-2.
- Wells, G.M., et al. "Effects of mirror surface roughness on exposure field uniformity in synchrotron x-ray lithography", American Vacuum Society, J. Vac. Sci. Technol., 1991, pp. 3227-3231.
- International Search Report and Written Opinion for PCT Patent Application No. PCT/US2010/024943, mailed Apr. 22, 2010, 9 pages.
- International Search Report and Written Opinion for PCT Patent Application No. PCT/US2008/71127, mailed Oct. 22, 2008, 9 pages.
- International Search Report and Written Opinion for PCT Patent Application No. PCT/US2008/059170 mailed Aug. 6, 2008, 8 pages.
- International Search Report and Written Opinion for PCT Patent Application No. PCT/US2008/075134 mailed Dec. 5, 2008, 9 pages.
- International Search Report and Written Opinion for PCT Patent Application No. PCT/US2008/064132 mailed Aug. 15, 2008, 8 pages.
- International Search Report and Written Opinion for PCT Patent Application No. PCT/US2006/35793, mailed May 10, 2007, 8 pages.
- International Search Report and Written Opinion of PCT Patent Application No. PCT/US2006/29164, mailed Jun. 5, 2008, 16 pages.
- International Search Report and Written Opinion for PCT Patent Application No. PCT/US2006/21803, dated Aug. 30, 2007, 21 pages.
- Office Action for U.S. Appl. No. 11/445,933 dated Apr. 14, 2010, 7 pages.
- Office Action for U.S. Appl. No. 11/445,933 dated Oct. 14, 2009, 8 pages.
- Office Action for U.S. Appl. No. 11/445,948 dated April 15, 2010, 27 pages.
- Office Action for U.S. Appl. No. 11/445,948 dated May 22, 2009, 18 pages.
- Office Action for U.S. Appl. No. 11/354,530 dated Jan. 6, 2010, 7 pages.
- Office Action for U.S. Appl. No. 11/493,380 dated Jul. 22, 2009, 22 pages.
- Office Action for U.S. Appl. No. 11/493,380 dated Feb. 17, 2009, 24 pages.
- Office Action for U.S. Appl. No. 11/493,380 dated May 30, 2008, 25 pages.
- Office Action for U.S. Appl. No. 12/136,572 dated Feb. 4, 2010, 15 pages.
- Office Action for U.S. Appl. No. 12/136,574 dated Jan. 12, 2010, 15 pages.
- Office Action for U.S. Appl. No. 12/136,574 dated Jun. 8, 2009, 10 pages.
- Office Action for U.S. Appl. No. 12/136,574 dated Dec. 29, 2008, 9 pages.
- Office Action for U.S. Appl. No. 12/136,577 dated Jun. 8, 2009, 12 pages.
- Office Action for U.S. Appl. No. 12/136,581 dated Feb. 4, 2010, 13 pages.
- Office Action for U.S. Appl. No. 11/0402,490 dated Oct. 30, 2009, 12 pages.
- Office Action for U.S. Appl. No. 11/0402,490 dated Mar. 3, 2009, 18 pages.
- Office Action for U.S. Appl. No. 12/167,198 dated Dec. 19, 2008, 15 pages.
- Office Action for U.S. Appl. No. 11/254,114 dated Feb. 2, 2010, 10 pages.
- Office Action for U.S. Appl. No. 11/253,182 dated Feb. 5, 2010, 6 pages.
- Office Action for U.S. Appl. No. 11/253,182 dated Jan. 8, 2009, 14 pages.
- Office Action for U.S. Appl. No. 11/252,425 dated Oct. 16, 2009, 6 pages.
- Office Action for U.S. Appl. No. 11/252,425 dated Mar. 19, 2009, 6 pages.
- Office Action for U.S. Appl. No. 11/252,425 dated Jul. 9, 2008, 15 pages.
- Office Action for U.S. Appl. No. 11/253,418 dated Sep. 11, 2009, 19 pages.
- Office Action for U.S. Appl. No. 11/253,202 dated Aug. 31, 2009, 22 pages.
- Office Action for U.S. Appl. No. 11/253,202 dated Feb. 19, 2009, 19 pages.
- Office Action for U.S. Appl. No. 11/252,399 dated Dec. 4, 2009, 22 pages.
- Office Action for U.S. Appl. No. 11/252,399 dated Jun. 2, 2009, 17 pages.
- Office Action for U.S. Appl. No. 11/252,399 dated Aug. 20, 2008, 16 pages.
- Office Action for U.S. Appl. No. 11/254,041 dated Jan. 26, 2010, 8 pages.
- Office Action for U.S. Appl. No. 11/290,313 dated April 15, 2010, 10 pages.
- Office Action for U.S. Appl. No. 11/290,313 dated Sep. 21, 2009, 7 pages.
- Office Action dated Mar. 31, 2010 for U.S. Appl. No. 11/753,546, 10 pages.
- Office Action for U.S. Appl. No. 12/332,340 dated Apr. 26, 2010, 17 pages.
- Office Action for U.S. Appl. No. 11/841,899 of Mar. 11, 2008, 18 pages.

* cited by examiner

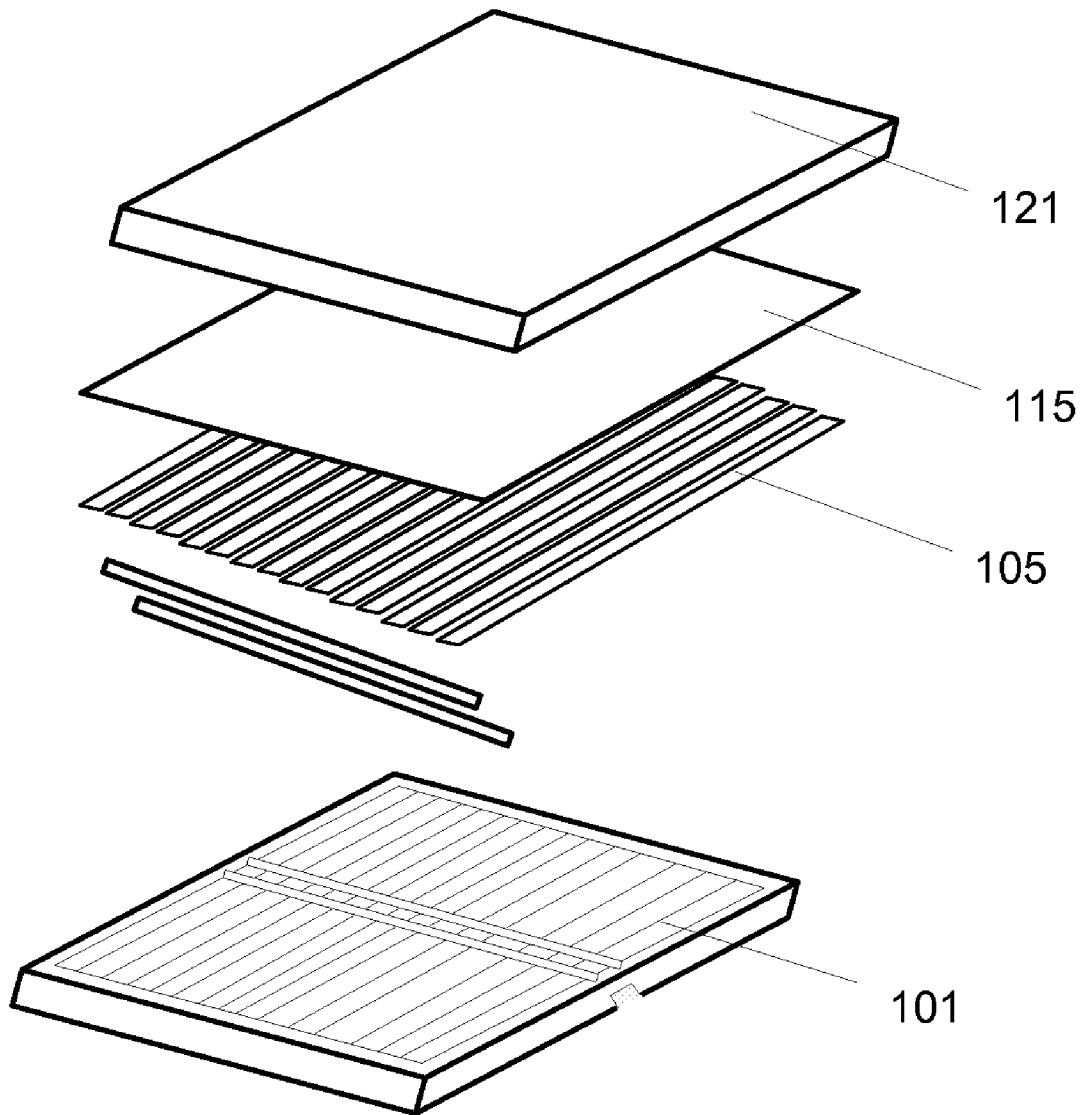

Figure 1

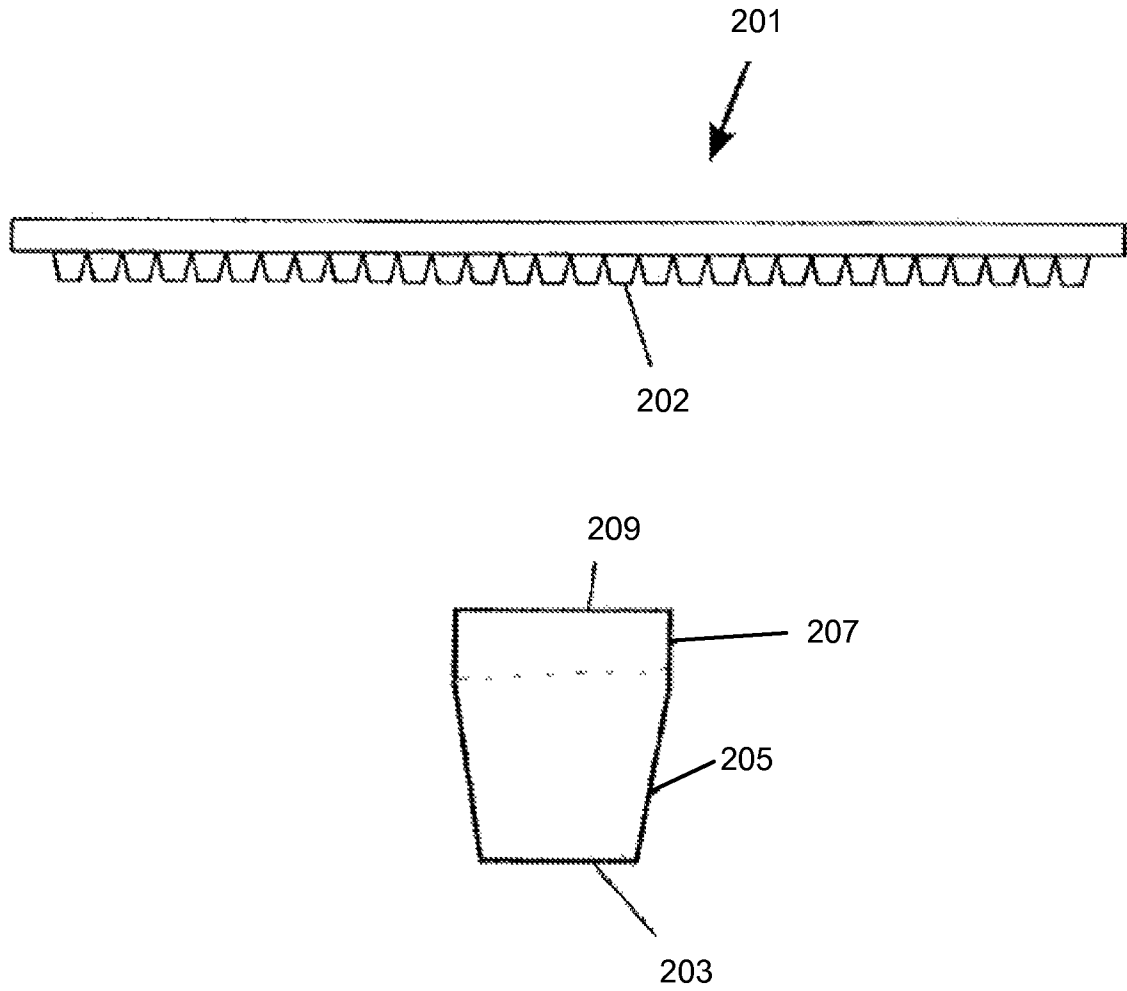

Figure 2

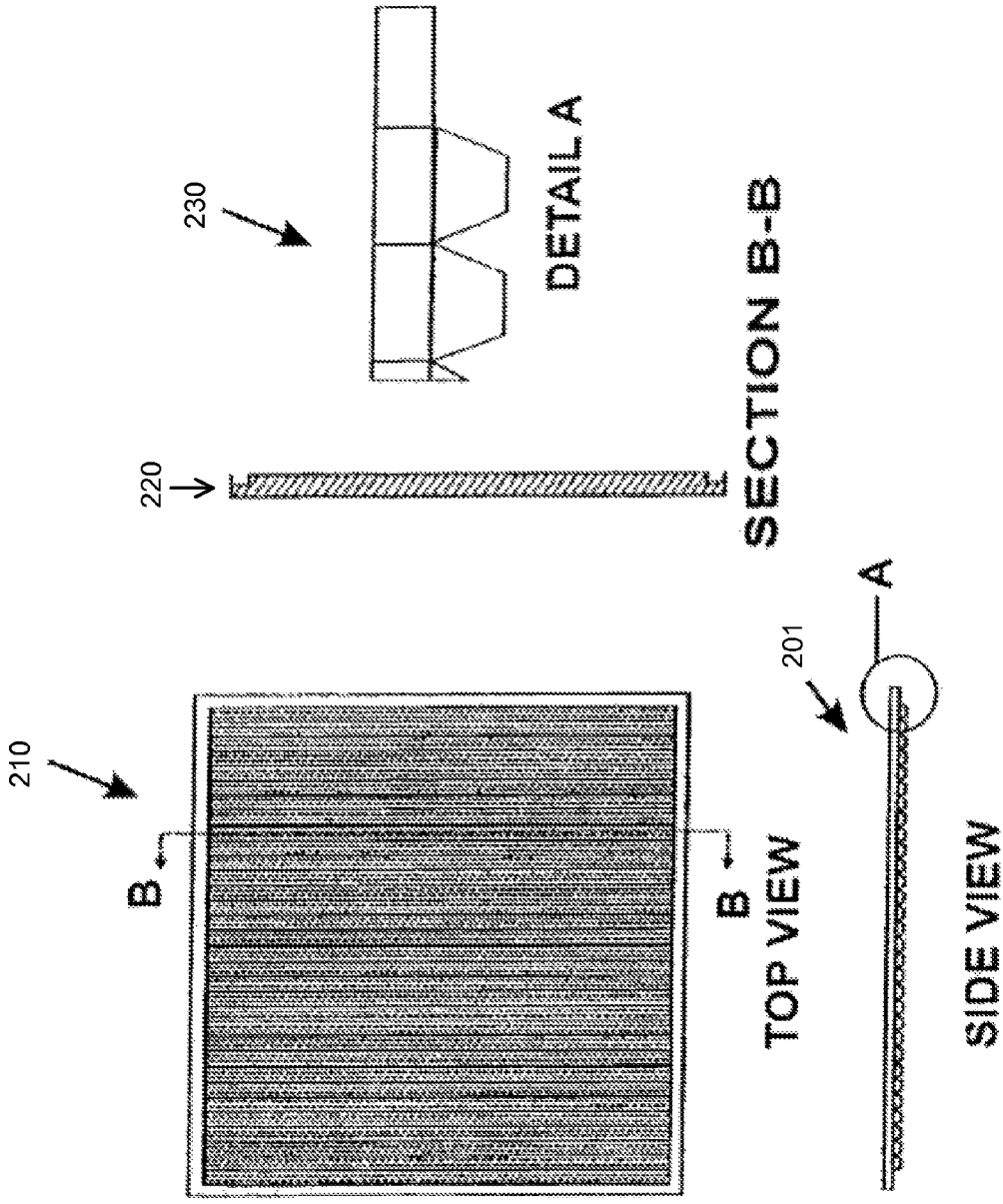

Figure 2A

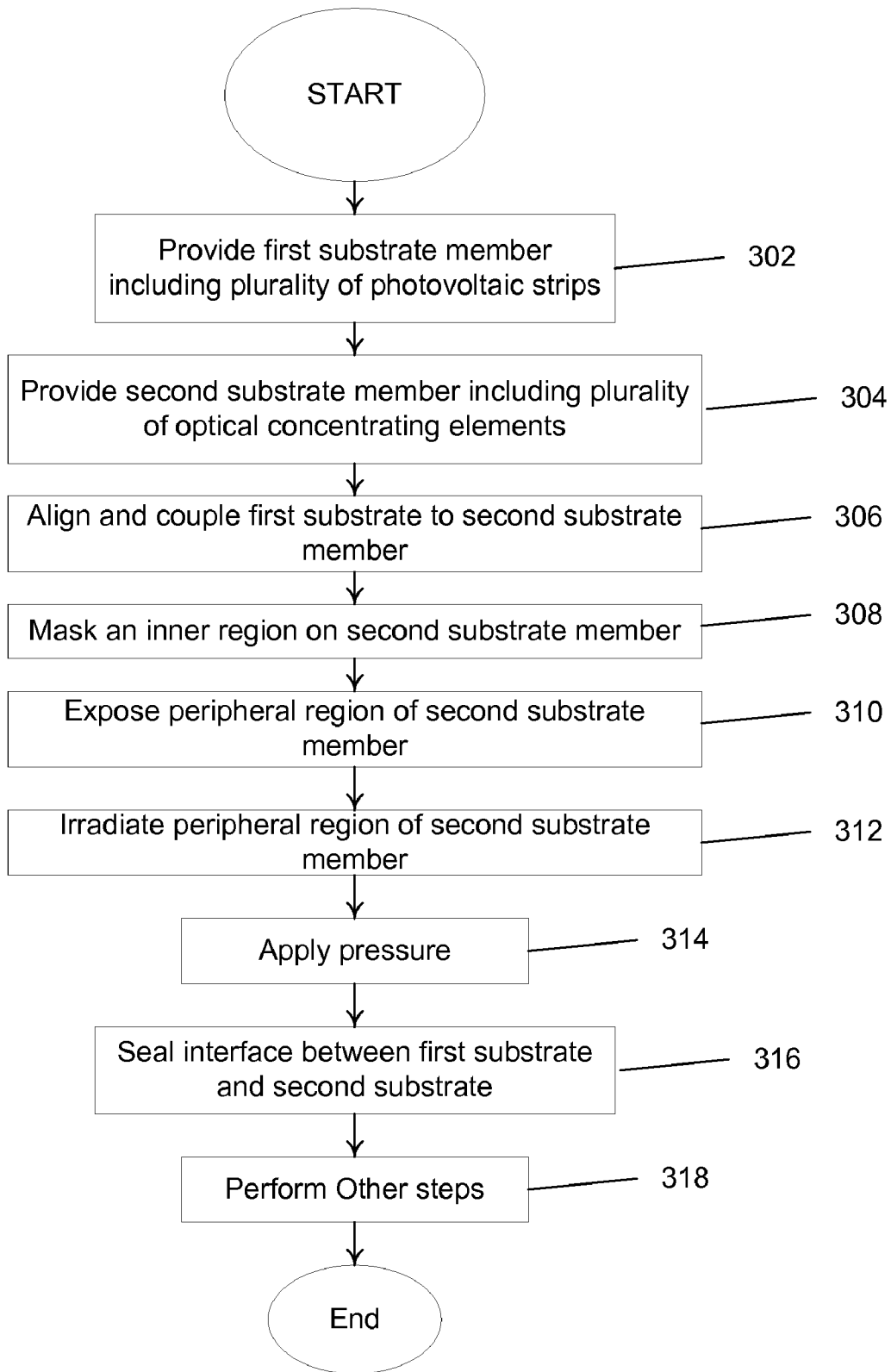

Figure 3

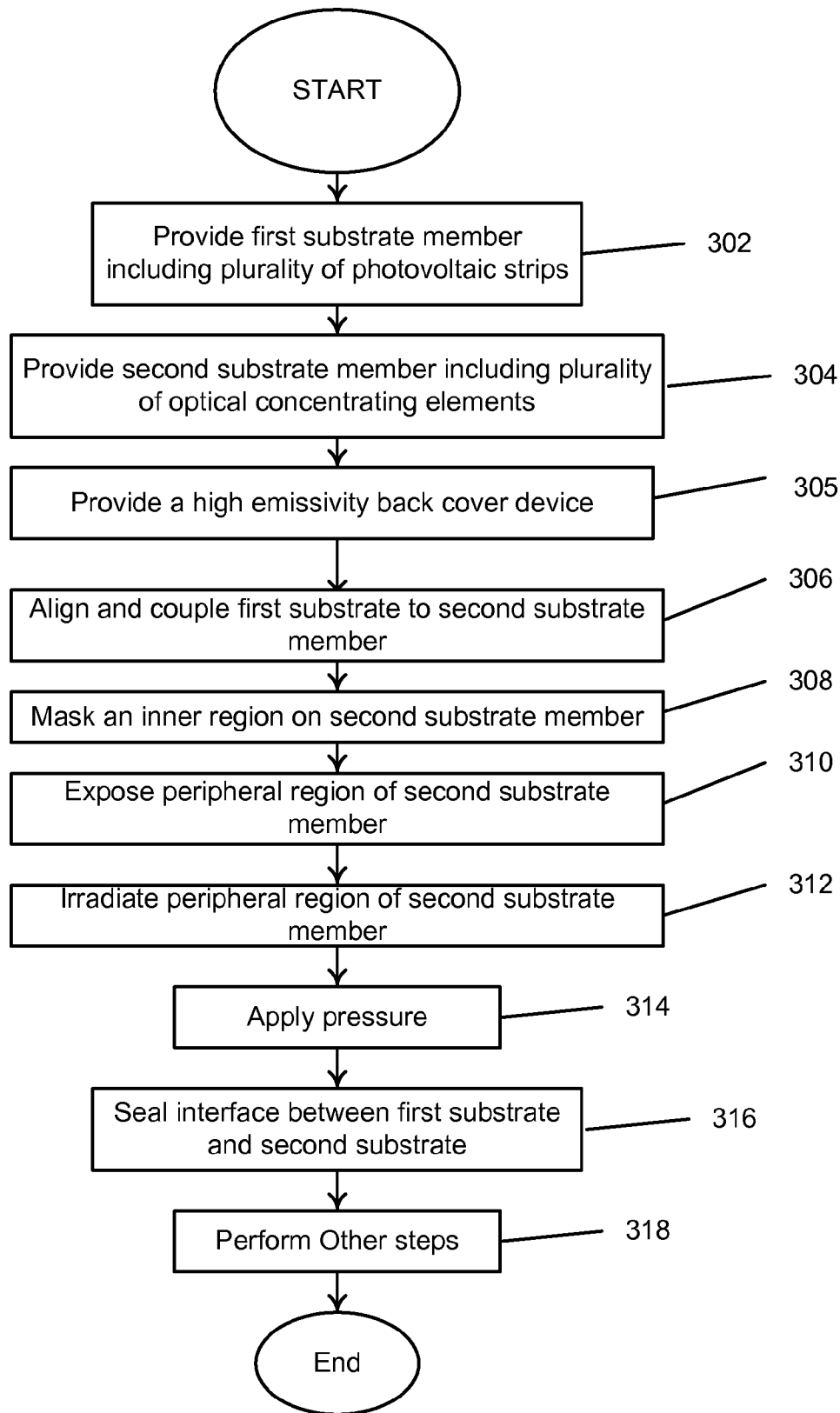

Figure 3A

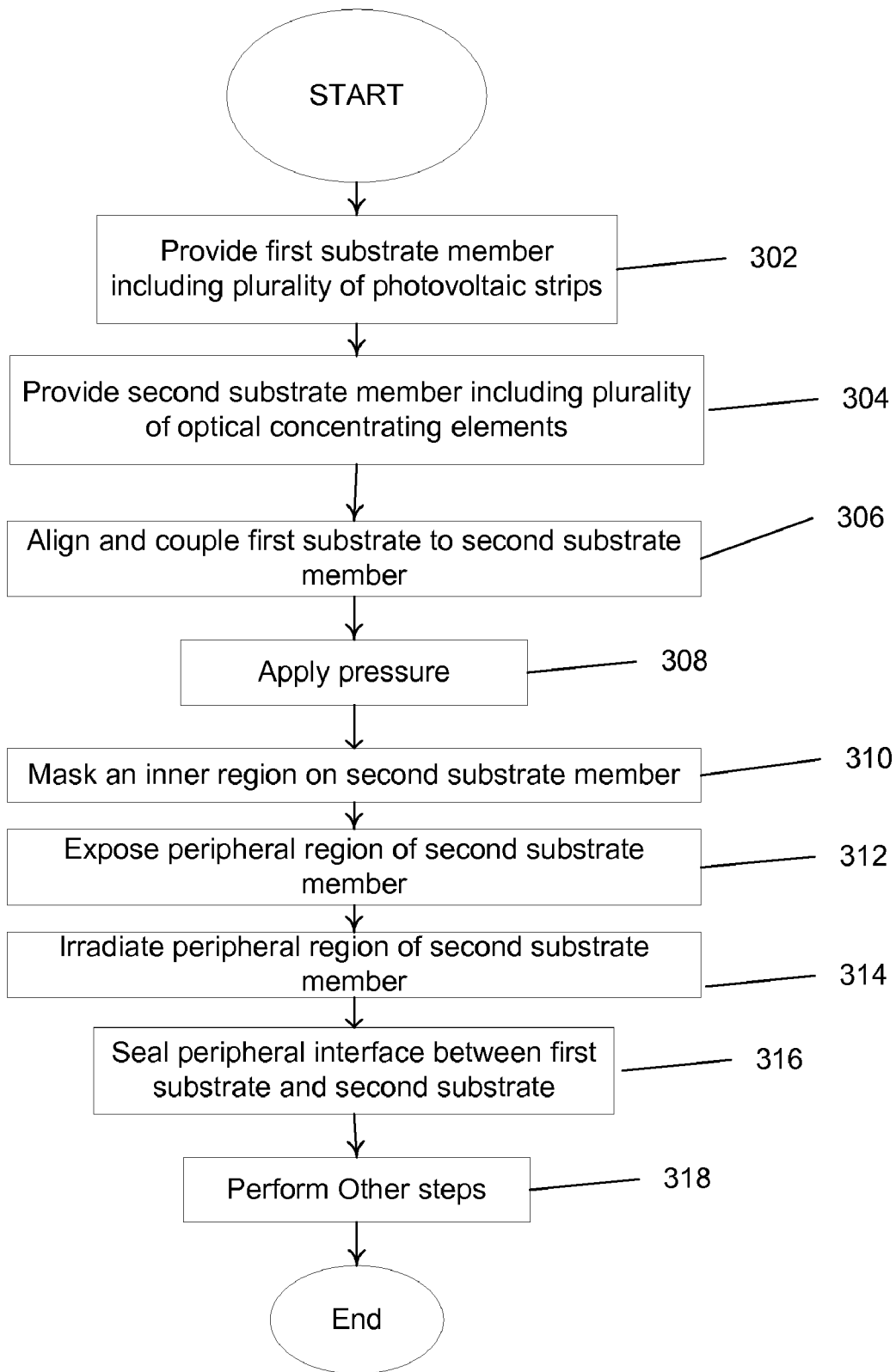

Figure 3B

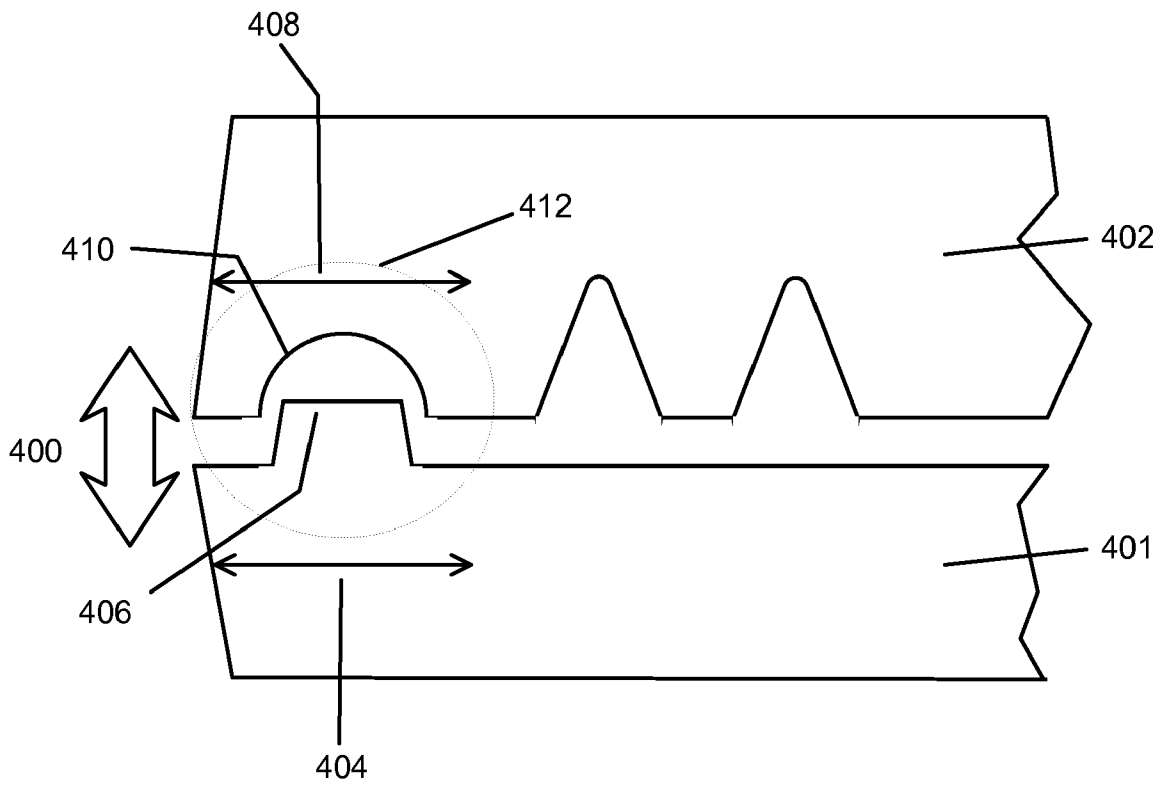

Figure 4

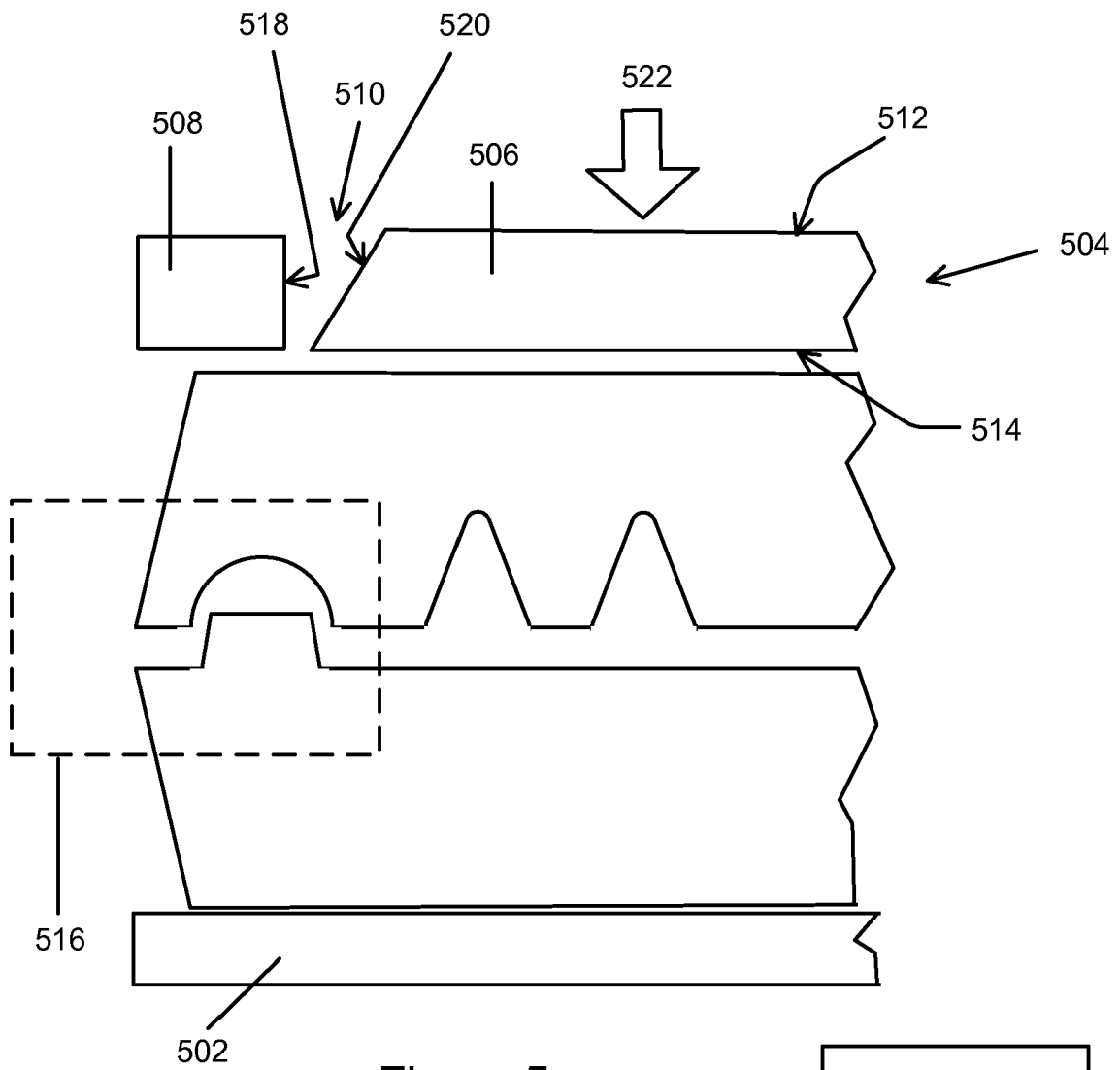

Figure 5

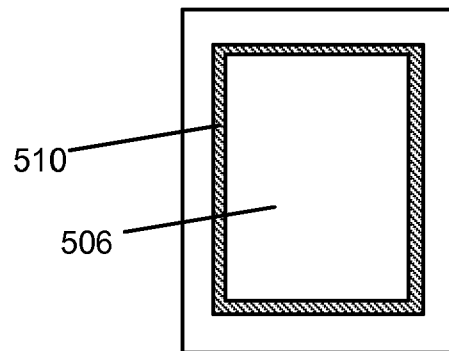

Figure 5A

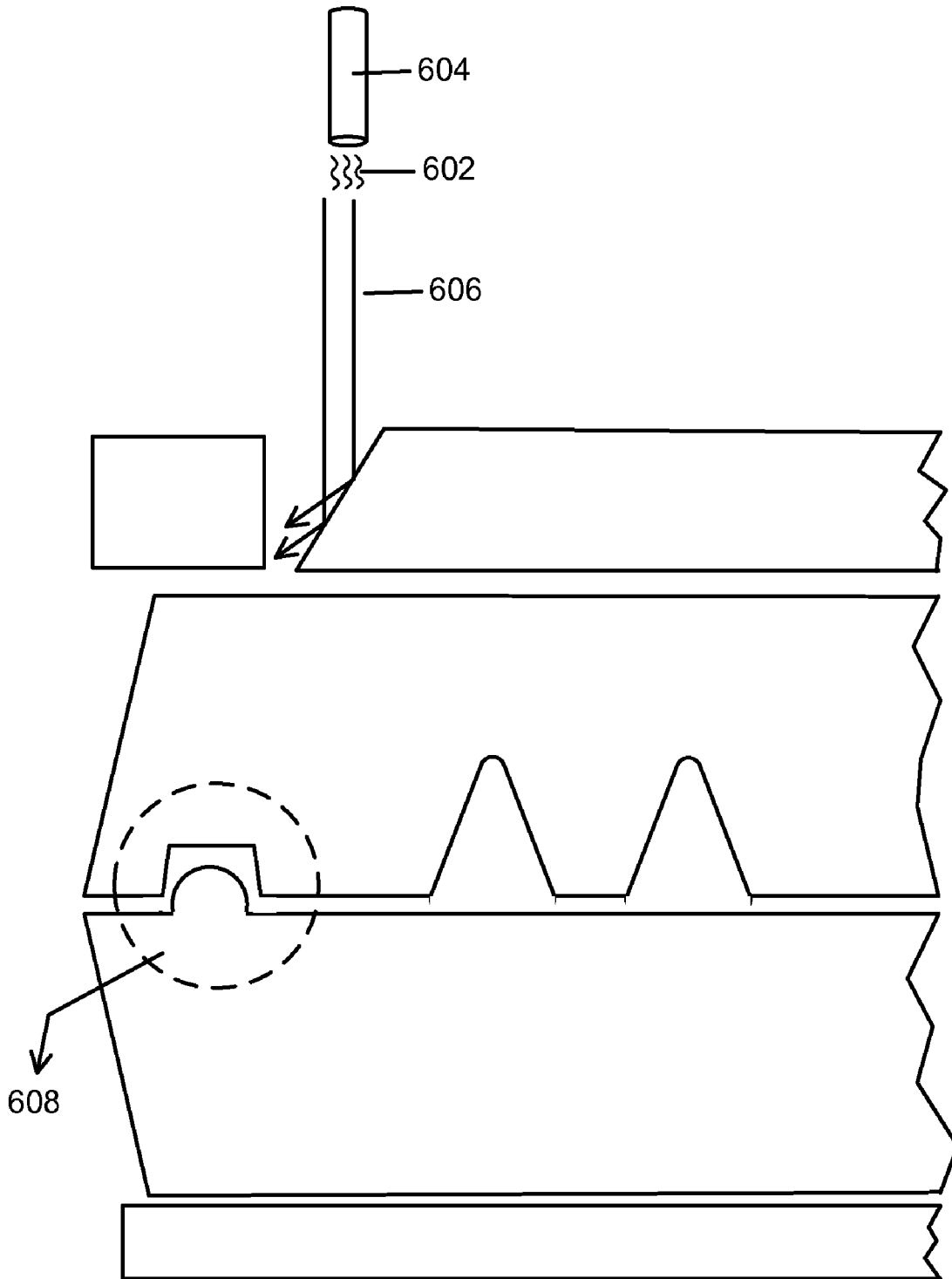

Figure 6

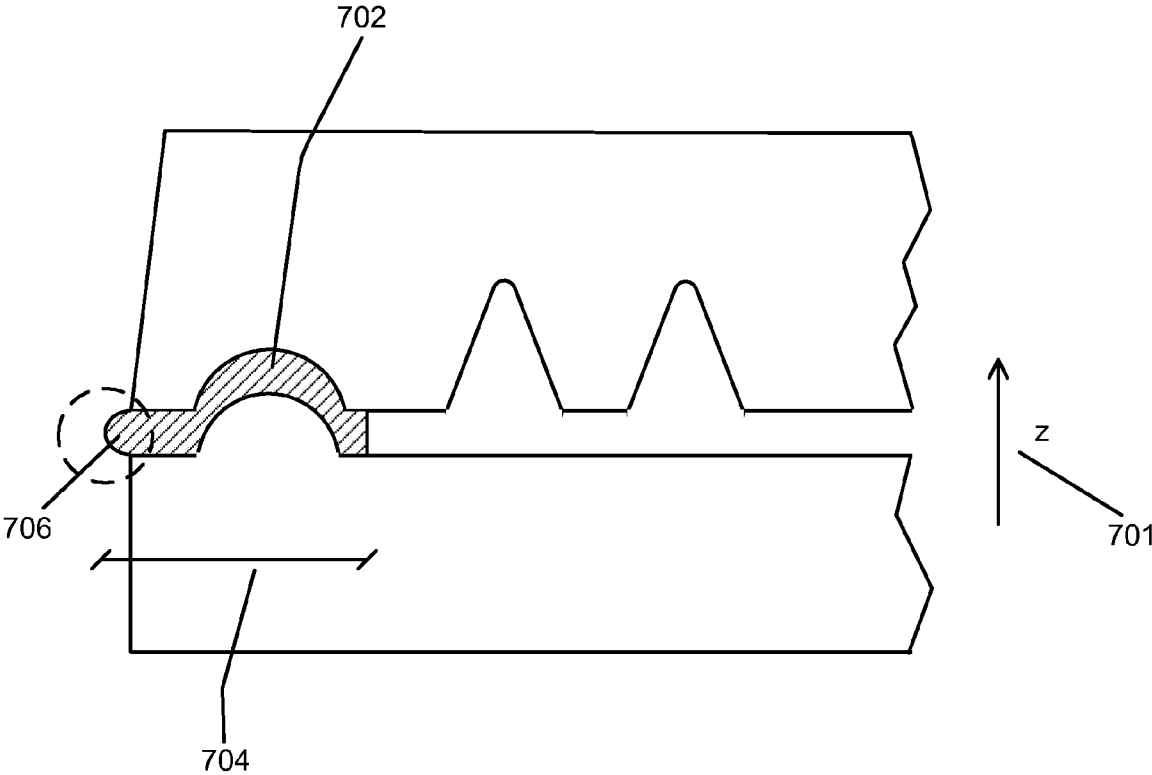

Figure 7

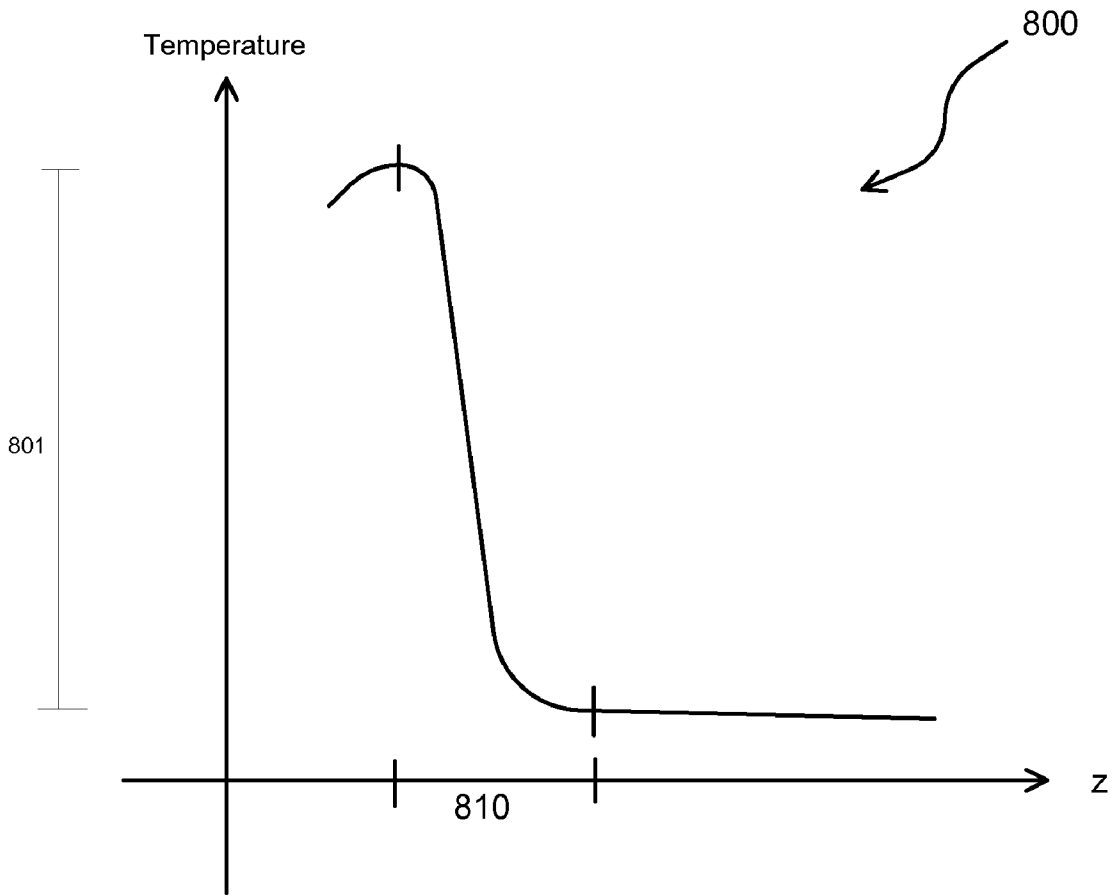

Figure 8

**METHOD AND SYSTEM FOR ASSEMBLING
A SOLAR CELL PACKAGE**

CROSS-REFERENCES TO RELATED
APPLICATIONS

This application claims priority to U.S. Patent Application No. 60/909,691, filed Apr. 2, 2007 and U.S. Patent Application No. 60/909,692, filed Apr. 2, 2007, both are commonly assigned and herein incorporated by reference for all purposes.

STATEMENT AS TO RIGHTS TO INVENTIONS
MADE UNDER FEDERALLY SPONSORED
RESEARCH OR DEVELOPMENT

Not Applicable

REFERENCE TO A "SEQUENCE LISTING," A
TABLE, OR A COMPUTER PROGRAM LISTING
APPENDIX SUBMITTED ON A COMPACT DISK

Not Applicable

BACKGROUND OF THE INVENTION

The present invention relates generally to solar energy techniques. In particular, the present invention provides a method and resulting device fabricated from a plurality of concentrating elements respectively coupled to a plurality of photovoltaic regions. For example, concentrating elements are coupled to a plurality of photovoltaic regions using one or more coupled structures. More particularly, the present method and structure are directed to a laser sealing technique of a solar cell package apparatus. Merely by way of example, the invention has been applied to solar panels, commonly termed modules, but it would be recognized that the invention has a much broader range of applicability.

As the population of the world increases, industrial expansion has lead to an equally large consumption of energy. Energy often comes from fossil fuels, including coal and oil, hydroelectric plants, nuclear sources, and others. As merely an example, the International Energy Agency projects further increases in oil consumption, with developing nations such as China and India accounting for most of the increase. Almost every element of our daily lives depends, in part, on oil, which is becoming increasingly scarce. As time further progresses, an era of "cheap" and plentiful oil is coming to an end. Accordingly, other and alternative sources of energy have been developed.

Concurrent with oil, we have also relied upon other very useful sources of energy such as hydroelectric, nuclear, and the like to provide our electricity needs. As an example, most of our conventional electricity requirements for home and business use comes from turbines run on coal or other forms of fossil fuel, nuclear power generation plants, and hydroelectric plants, as well as other forms of renewable energy. Often times, home and business use of electrical power has been stable and widespread.

Most importantly, much if not all of the useful energy found on the Earth comes from our sun. Generally all common plant life on the Earth achieves life using photosynthesis processes from sun light. Fossil fuels such as oil were also developed from biological materials derived from energy associated with the sun. For human beings including "sun worshippers," sunlight has been essential. For life on the planet

Earth, the sun has been our most important energy source and fuel for modern day solar energy.

Solar energy possesses many characteristics that are very desirable! Solar energy is renewable, clean, abundant, and often widespread. Certain technologies developed often capture solar energy, concentrate it, store it, and convert it into other useful forms of energy.

Solar panels have been developed to convert sunlight into energy. As merely an example, solar thermal panels often convert electromagnetic radiation from the sun into thermal energy for heating homes, running certain industrial processes, or driving high grade turbines to generate electricity. As another example, solar photovoltaic panels convert sunlight directly into electricity for a variety of applications. Solar panels are generally composed of an array of solar cells, which are interconnected to each other. The cells are often arranged in series and/or parallel groups of cells in series. Accordingly, solar panels have great potential to benefit our nation, security, and human users. They can even diversify our energy requirements and reduce the world's dependence on oil and other potentially detrimental sources of energy.

Although solar panels have been used successful for certain applications, there are still certain limitations. Solar cells are often costly. Depending upon the geographic region, there are often financial subsidies from governmental entities for purchasing solar panels, which often cannot compete with the direct purchase of electricity from public power companies. Additionally, the panels are often composed of silicon bearing wafer materials. Such wafer materials are often costly and difficult to manufacture efficiently on a large scale. Availability of solar panels is also somewhat scarce. That is, solar panels are often difficult to find and purchase from limited sources of photovoltaic silicon bearing materials. These and other limitations are described throughout the present specification, and may be described in more detail below.

From the above, it is seen that techniques for improving solar devices is highly desirable.

BRIEF SUMMARY OF THE INVENTION

The present invention relates generally to solar energy techniques. In particular, the present invention provides a method and resulting device fabricated from a plurality of concentrating elements respectively coupled to a plurality of photovoltaic regions. For example, concentrating elements are coupled to a plurality of photovoltaic regions using one or more coupled structures. More particularly, the present method and structure are directed to a laser sealing technique of a solar cell package apparatus. Merely by way of example, the invention has been applied to solar panels, commonly termed modules, but it would be recognized that the invention has a much broader range of applicability.

In a specific embodiment, the present invention provides a method for fabricating solar cell for a solar panel. The method includes providing a first substrate member comprising a plurality of photovoltaic strips thereon. The method includes providing an optical elastomer material overlying a portion of the first substrate member. In a specific embodiment, the method aligns a second substrate member comprising a plurality of optical concentrating elements thereon such that at least one of the optical concentrating elements is operably coupled to at least one of the plurality of photovoltaic strips. In a specific embodiment, the second substrate member comprises an aperture surface region and an exit surface region. The method couples the first substrate member to the second substrate member to form an interface region along a first peripheral region of the first substrate member and a second

peripheral region of the second substrate member. In a specific embodiment, the method includes blocking an inner region of the aperture surface region of the second substrate member while exposing the peripheral region of the aperture surface region of the second substrate member.

According to another embodiment, the present invention provides A method for fabricating a solar cell free and separate from a solar panel. The method includes providing a first substrate member comprising a plurality of photovoltaic strips thereon, the first substrate member having a first peripheral region, the first peripheral region including a first flat region and a first structure region, the first structure region including a protruding structure. The method also includes providing an optical elastomer material overlying a portion of the first substrate member. Furthermore, the method includes providing a second substrate member having a second peripheral region, the second peripheral region including a second flat region and a second structure region, the second structure region including an indent structure. Additionally, the method includes aligning the second substrate member comprising a plurality of optical concentrating elements thereon such that the first flat region of the first substrate mates with the second flat region of the second substrate and the first structure region, the second substrate member comprising an aperture surface region and an exit surface region. The method also includes coupling the first substrate member to the second substrate member to form a sealing region between the first peripheral region of the first substrate member and the second peripheral region of the second substrate member and to engage the first structure region of the first substrate to the second structure region of the second substrate.

According to yet another embodiment, the present invention provides a solar cell package. The package includes a first substrate member comprising a plurality of photovoltaic strips thereon, the first substrate member having a first peripheral region, the first peripheral region including a first flat region and a first structure region, the first structure region comprising an protruding structure. The package also includes an optical elastomer material overlying a portion of the first substrate member. The package also includes a second substrate member having a second peripheral region, the second peripheral region including a second flat region and a second structure region, the second substrate being aligned such that the first flat region of the first substrate mates with the second flat region of the second substrate and the first structure region, the second substrate member comprising an aperture surface region and an exit surface region, the second structure region comprising an indent structure.

In a specific embodiment, the method also irradiates an entirety of the second peripheral region of the second substrate member using electromagnetic radiation to seal the interface region between the second substrate and the first substrate. In a preferred embodiment, the blocking selectively allows for irradiation of the second peripheral region of the second substrate member to seal the interface region. In an alternative embodiment, irradiating an entirety of the second peripheral region of the second substrate member uses a flash or pulses of electromagnetic radiation to seal the interface region between the second substrate and the first substrate, while the inner region of the aperture surface region remains blocked using blocking material.

In an alternative embodiment, the invention provides a system for manufacture of solar cells. In a specific embodiment, the apparatus has a stage member, which can be a mechanical attachment member, vacuum member, or other suitable device. The apparatus has a first substrate member comprising a plurality of photovoltaic regions thereon pro-

vided on the stage member, an optical elastomer material overlying a portion of the first substrate member, an aligned second substrate member comprising a plurality of optical concentrating elements thereon such that at least one of the optical concentrating elements being operably coupled to at least one of the plurality of photovoltaic strips, the second substrate member comprising an aperture surface region and an exit surface region, and an interface region provided along a first peripheral region of the first substrate member and a second peripheral region of the second substrate member. In a preferred embodiment, a blocking member is provided within an inner region of the aperture surface region of the second substrate member while exposing the peripheral region of the aperture surface region of the second substrate member. The apparatus also has an irradiation source coupled to the stage member. In a specific embodiment, the irradiation source is adapted to irradiate an entirety of the second peripheral region of the second substrate member using a flash or pulses of electromagnetic radiation to seal the interface region between the second substrate and the first substrate, while the inner region of the aperture surface region remains blocked using blocking material.

Many benefits are achieved by way of the present invention over conventional techniques. For example, the present technique provides an easy to use process that relies upon conventional technology such as silicon materials, although other materials can also be used. Additionally, the method provides a process that is compatible with conventional process technology without substantial modifications to conventional equipment and processes. Preferably, the invention provides for an improved solar cell, which is less costly and easy to handle. Such solar cell uses a plurality of photovoltaic regions, which are sealed within one or more substrate structures according to a preferred embodiment. In a preferred embodiment, the invention provides a method and completed solar cell structure using a plurality of photovoltaic strips free and clear from a module or panel assembly, which are provided during a later assembly process. Also in a preferred embodiment, one or more of the solar cells have less silicon per area (e.g., 80% or less, 50% or less) than conventional solar cells. In preferred embodiments, the present method and cell structures are also light weight and not detrimental to building structures and the like. That is, the weight is about the same or slightly more than conventional solar cells at a module level according to a specific embodiment. In a preferred embodiment, the present solar cell using the plurality of photovoltaic strips can be used as a "drop in" replacement of conventional solar cell structures. As a drop in replacement, the present solar cell can be used with conventional solar cell technologies for efficient implementation according to a preferred embodiment. In a preferred embodiment, the present method and system provide a way of sealing an interface region between two substrate members using an electromagnetic radiation source, which is relatively easy to use and cost effective. Depending upon the embodiment, one or more of these benefits may be achieved. These and other benefits will be described in more detail throughout the present specification and more particularly below.

Various additional objects, features and advantages of the present invention can be more fully appreciated with reference to the detailed description and accompanying drawings that follow.

BRIEF DESCRIPTION OF THE DRAWINGS

FIG. 1 is a simplified diagram of a solar cell according to an embodiment of the present invention;

5

FIG. 2 is a simplified diagram of solar cell concentrating elements according to an embodiment of the present invention;

FIG. 2A is a simplified side-view diagram of solar cell concentrating elements according to an embodiment of the present invention;

FIGS. 3, 3A, and 3B are simplified flow diagrams illustrating a method of assembling a solar cell apparatus according to an embodiment of the present invention;

FIG. 4 is a simplified diagram of coupling a back cover member to a concentrator member according to an embodiment of the present invention;

FIGS. 5 and 5A are a simplified diagrams of irradiating peripheral regions of the concentrator member and back cover member to seal them together according to an embodiment of the present invention;

FIG. 6 is a simplified side-view diagram of a concentrator member and a back cover according to an embodiment of the present invention;

FIG. 7 is a more detailed diagram of a back cover device and a concentrator device according to an embodiment of the present invention; and

FIG. 8 is a simplified plot of temperature gradient in z direction in the seal region according to an embodiment of the present invention.

DETAILED DESCRIPTION OF THE INVENTION

The present invention relates generally to solar energy techniques. In particular, the present invention provides a method and resulting device fabricated from a plurality of concentrating elements respectively coupled to a plurality of photovoltaic regions. For example, concentrating elements are coupled to a plurality of photovoltaic regions using one or more coupled structures. More particularly, the present method and structure are directed to a laser sealing technique of a solar cell package apparatus. Merely by way of example, the invention has been applied to solar panels, commonly termed modules, but it would be recognized that the invention has a much broader range of applicability.

FIG. 1 is a simplified diagram of a solar cell according to an embodiment of the present invention. This diagram is merely an example, which should not unduly limit the scope of the claims herein. One of ordinary skill in the art would recognize other variations, modifications, and alternatives. As shown is an expanded view of the present solar cell device structure, which includes various elements. The device has a back cover member 101, which includes a surface area and a back area. The back cover member also has a plurality of sites, which are spatially disposed, for electrical members, such as bus bars, and a plurality of photovoltaic regions. Alternatively, the back cover can be free from any patterns and is merely provided for support and packaging. Of course, there can be other variations, modifications, and alternatives.

In a preferred embodiment, the device has a plurality of photovoltaic strips 105, each of which is disposed overlying the surface area of the back cover member. In a preferred embodiment, the plurality of photovoltaic strips corresponds to a cumulative area occupying a total photovoltaic spatial region, which is active and converts sunlight into electrical energy.

An encapsulating material 115 is overlying a portion of the back cover member. That is, an encapsulating material forms overlying the plurality of strips, and exposed regions of the back cover, and electrical members. In a preferred embodiment, the encapsulating material can be a single layer, multiple layers, or portions of layers, depending upon the appli-

6

cation. In alternative embodiments, as noted, the encapsulating material can be provided overlying a portion of the photovoltaic strips or a surface region of the front cover member, which would be coupled to the plurality of photovoltaic strips. Of course, there can be other variations, modifications, and alternatives.

In a specific embodiment, a front cover member 121 is coupled to the encapsulating material. That is, the front cover member is formed overlying the encapsulant to form a multilayered structure including at least the back cover, bus bars, plurality of photovoltaic strips, encapsulant, and front cover. In a preferred embodiment, the front cover includes one or more concentrating elements, which concentrate (e.g., intensify per unit area) sunlight onto the plurality of photovoltaic strips. That is, each of the concentrating elements can be associated respectively with each of or at least one of the photovoltaic strips.

Upon assembly of the back cover, bus bars, photovoltaic strips, encapsulant, and front cover, an interface region is provided along at least a peripheral region of the back cover member and the front cover member. The interface region may also be provided surrounding each of the strips or certain groups of the strips depending upon the embodiment. The device has a sealed region and is formed on at least the interface region to form an individual solar cell from the back cover member and the front cover member. The sealed region maintains the active regions, including photovoltaic strips, in a controlled environment free from external effects, such as weather, mechanical handling, environmental conditions, and other influences that may degrade the quality of the solar cell. Additionally, the sealed region and/or sealed member (e.g., two substrates) protect certain optical characteristics associated with the solar cell and also protects and maintains any of the electrical conductive members, such as bus bars, interconnects, and the like. Of course, there can be other benefits achieved using the sealed member structure according to other embodiments.

In a preferred embodiment, the total photovoltaic spatial region occupies a smaller spatial region than the surface area of the back cover. That is, the total photovoltaic spatial region uses less silicon than conventional solar cells for a given solar cell size. In a preferred embodiment, the total photovoltaic spatial region occupies about 80% and less of the surface area of the back cover for the individual solar cell. Depending upon the embodiment, the photovoltaic spatial region may also occupy about 70% and less or 60% and less or preferably 50% and less of the surface area of the back cover or given area of a solar cell. Of course, there can be other percentages that have not been expressly recited according to other embodiments. Here, the terms "back cover member" and "front cover member" are provided for illustrative purposes, and not intended to limit the scope of the claims to a particular configuration relative to a spatial orientation according to a specific embodiment. Further details of each of the various elements in the solar cell can be found throughout the present specification and more particularly below.

In a specific embodiment, the present invention provides a packaged solar cell assembly being capable of stand-alone operation to generate power using the packaged solar cell assembly and/or with other solar cell assemblies. The packaged solar cell assembly includes rigid front cover member having a front cover surface area and a plurality of concentrating elements thereon. Depending upon applications, the rigid front cover member consists of a variety of materials. For example, the rigid front cover is made of polymer material. As another example, the rigid front cover is made of transparent polymer material having a reflective index of

about 1.4 or 1.42 or greater. According to an example, the rigid front cover has a Young's Modulus of a suitable range. Each of the concentrating elements has a length extending from a first portion of the front cover surface area to a second portion of the front cover surface area. Each of the concentrating elements has a width provided between the first portion and the second portion. Each of the concentrating elements having a first edge region coupled to a first side of the width and a second edge region provided on a second side of the width. The first edge region and the second edge region extend from the first portion of the front cover surface area to a second portion of the front cover surface area. The plurality of concentrating elements is configured in a parallel manner extending from the first portion to the second portion.

It is to be appreciated that embodiment can have many variations. For example, the embodiment may further include a first electrode member that is coupled to a first region of each of the plurality of photovoltaic strips and a second electrode member coupled to a second region of each of the plurality of photovoltaic strips.

As another example, the solar cell assembly additionally includes a first electrode member coupled to a first region of each of the plurality of photovoltaic strips and a second electrode member coupled to a second region of each of the plurality of photovoltaic strips. The first electrode includes a first protruding portion extending from a first portion of the sandwiched assembly and the second electrode comprising a second protruding portion extending from a second portion of the sandwiched assembly.

In yet another specific embodiment, the present invention provides a solar cell apparatus. The solar cell apparatus includes a backside substrate member comprising a backside surface region and an inner surface region. Depending upon application, the backside substrate member can be made from various materials. For example, the backside member is characterized by a polymer material.

In yet another embodiment, the present invention provides a solar cell apparatus that includes a backside substrate member. The backside substrate member includes a backside surface region and an inner surface region. The backside substrate member is characterized by a width. For example, the backside substrate member is characterized by a length of about eight inches and less. As an example, the backside substrate member is characterized by a width of about 8 inches and less and a length of more than 8 inches. Of course, there can be other variations, modifications, and alternatives. Further details of the solar cell assembly can be found in U.S. patent application Ser. No. 11/445,993, commonly assigned, and hereby incorporated by reference herein.

FIG. 2 is a simplified diagram of solar cell concentrating elements 201 according to an embodiment of the present invention. This diagram is merely an example, which should not unduly limit the scope of the claims herein. One of ordinary skill in the art would recognize other variations, modifications, and alternatives. As shown, each of the concentrating elements for the strip configuration includes a trapezoidal shaped member 205. Each of the trapezoidal shaped members has a bottom surface 203 coupled to a pyramidal shaped region coupled to an upper region 207. The upper region is defined by surface 209, which is co-extensive of the front cover. Each of the members is spatially disposed and in parallel to each other according to a specific embodiment. Here, the term "trapezoidal" or "pyramidal" may include embodiments with straight or curved or a combination of straight and curved walls according to embodiments of the present invention. Depending upon the embodiment, the concentrating elements may be on the front cover, integrated into the front

cover, and/or be coupled to the front cover according to embodiments of the present invention. Further details of the front cover with concentrating elements are provided more particularly below.

In a specific embodiment, a solar cell apparatus includes a shaped concentrator device operably coupled to each of the plurality of photovoltaic strips. The shaped concentrator device has a first side and a second side. In addition, the solar cell apparatus includes an aperture region provided on the first side of the shaped concentrator device. As merely an example, the concentrator device includes a first side region and a second side region. Depending upon application, the first side region is characterized by a roughness of about 100 nanometers or 120 nanometers RMS and less, and the second side region is characterized by a roughness of about 100 nanometers or 120 nanometers RMS and less. For example, the roughness is characterized by a dimension value of about 10% of a light wavelength derived from the aperture regions. Depending upon applications, the backside member can have a pyramid-type shape.

As an example, the solar cell apparatus includes an exit region provided on the second side of the shaped concentrator device. In addition, the solar cell apparatus includes a geometric concentration characteristic provided by a ratio of the aperture region to the exit region. The ratio can be characterized by a range from about 1.8 to about 4.5. The solar cell apparatus also includes a polymer material characterizing the shaped concentrator device. The solar cell apparatus additionally includes a refractive index of about 1.45 and greater characterizing the polymer material of the shaped concentrator device. Additionally, the solar cell apparatus includes a coupling material formed overlying each of the plurality of photovoltaic strips and coupling each of the plurality of photovoltaic regions to each of the concentrator devices. For example, the coupling material is characterized by a suitable Young's Modulus.

As merely an example, the solar cell apparatus includes a refractive index of about 1.45 and greater characterizing the coupling material coupling each of the plurality of photovoltaic regions to each of the concentrator device. Depending upon application, the polymer material is characterized by a thermal expansion constant that is suitable to withstand changes due to thermal expansion of elements of the solar cell apparatus.

For certain applications, the plurality of concentrating elements has a light entrance area (A1) and a light exit area (A2) such that $A2/A1$ is 0.8 and less. As merely an example, the plurality of concentrating elements has a light entrance area (A1) and a light exit area (A2) such that $A2/A1$ is 0.8 and less, and the plurality of photovoltaic strips are coupled against the light exit area. In a preferred embodiment, the ratio of $A2/A1$ is about 0.5 and less. For example, each of the concentrating elements has a height of 7 mm or less. In a specific embodiment, the sealed sandwiched assembly has a width ranging from about 100 millimeters to about 210 millimeters and a length ranging from about 100 millimeters to about 210 millimeters. In a specific embodiment, the sealed sandwiched assembly can even have a length of about 300 millimeters and greater. As another example, each of the concentrating elements has a pair of sides. In a specific embodiment, each of the sides has a surface finish of 100 nanometers or less or 120 nanometers and less RMS. Of course, there can be other variations, modifications, and alternatives.

Referring now to FIG. 2A, the front cover has been illustrated using a side view 201, which is similar to FIG. 2. The front cover also has a top-view illustration 210. A section view 220 from "B-B" has also been illustrated. A detailed

view “A” of at least two of the concentrating elements **230** is also shown. Depending upon the embodiment, there can be other variations, modifications, and alternatives.

Depending upon the embodiment, the concentrating elements are made of a suitable material. The concentrating elements can be made of a polymer, glass, or other optically transparent materials, including any combination of these, and the like. The suitable material is preferably environmentally stable and can withstand environmental temperatures, weather, and other “outdoor” conditions. The concentrating elements can also include portions that are coated with an anti-reflective coating for improved efficiency. Coatings can also be used for improving a durability of the concentrating elements. Of course, there can be other variations, modifications, and alternatives.

In a specific embodiment, the solar cell apparatus includes a first reflective side provided between a first portion of the aperture region and a first portion of the exit region. As merely an example, the first reflective side includes a first polished surface of a portion of the polymer material. For certain applications, the first reflective side is characterized by a surface roughness of about 120 nanometers RMS and less.

Moreover, the solar cell apparatus includes a second reflective side provided between a second portion of the aperture region and a second portion of the exit region. For example, the second reflective side comprises a second polished surface of a portion of the polymer material. For certain applications, the second reflective side is characterized by a surface roughness of about 120 nanometers and less. As an example, the first reflective side and the second reflective side provide for total internal reflection of one or more photons provided from the aperture region.

In addition, the solar cell apparatus includes a geometric concentration characteristic provided by a ratio of the aperture region to the exit region. The ratio is characterized by a range from about 1.8 to about 4.5. Additionally, the solar cell apparatus includes a polymer material characterizing the shaped concentrator device, which includes the aperture region, exit region, first reflective side, and second reflective side. As an example, the polymer material is capable of being free from damaged caused by ultraviolet radiation.

Furthermore, the solar cell apparatus has a refractive index of about 1.45 and greater characterizing the polymer material of the shaped concentrator device. Moreover, the solar cell apparatus includes a coupling material formed overlying each of the plurality of photovoltaic strips and coupling each of the plurality of photovoltaic regions to each of the concentrator devices. The solar cell apparatus additionally includes one or more pocket regions facing each of the first reflective side and the second reflective side. The one or more pocket regions can be characterized by a refractive index of about 1 to cause one or more photons from the aperture region to be reflected toward the exit region. To maintain good efficiency of the subject concentrator devices, each of the concentrating elements is separated by a region having a notch structure of a predetermined size and shape according to a specific embodiment. Of course there can be other variations, modifications, and alternatives. Further details of the notch structures can be found throughout the present specification and more particularly below.

FIG. 3 is a simplified flow diagram illustrating a method of assembling a solar cell apparatus according to an embodiment of the present invention. This diagram is merely an example, which should not unduly limit the scope of the claims herein. One of ordinary skill in the art would recognize other variations, modifications, and alternatives. As shown, the method provides a first substrate member (Step **302**). The

first substrate member includes a plurality of photovoltaic strips thereon. The method provides a second substrate member (Step **304**) which includes a plurality of optical concentrating elements. The first substrate member is aligned and couple to the second substrate member (Step **306**). In a specific embodiment, an inner region of the second substrate member (Step **308**) is blocked from irradiation while a peripheral region remained exposed (Step **310**). A pressure is applied (Step **314**). The method includes irradiating the exposed peripheral region of the second substrate member (Step **312**) and forming a melting region in an interface region between the first substrate member and the second substrate member. The melting region is used to seal peripheral interface between first substrate and second substrate (Step **316**). The method continues with other steps (Step **318**) to complete the solar cell panel.

The above sequence of steps provide a method for assembling a solar cell panel according to an embodiment of the present invention. Alternatively, one or more of the steps may be performed, one or more steps may be eliminated, or one or more steps may be performed in a different sequence depending on the embodiment. One skilled in the art would recognize many other variations, modifications, and alternatives.

FIG. 3A is a simplified flow diagram illustrating a method of assembling a solar cell apparatus according to an embodiment of the present invention. This diagram is merely an example, which should not unduly limit the scope of the claims herein. One of ordinary skill in the art would recognize other variations, modifications, and alternatives. As shown, the method provides a first substrate member (Step **302**). The first substrate member includes a plurality of photovoltaic strips thereon. The method provides a second substrate member (Step **304**) which includes a plurality of optical concentrating elements. The method also includes providing a high emissivity back cover device (Step **305**). The first substrate member is aligned and couple to the second substrate member (Step **306**). In a specific embodiment, an inner region of the second substrate member (Step **308**) is blocked from irradiation while a peripheral region remained exposed (Step **310**). A pressure is applied (Step **314**). The method includes irradiating the exposed peripheral region of the second substrate member (Step **312**) and forming a melting region in an interface region between the first substrate member and the second substrate member. As an example, laser is used for providing irradiation. The melting region is used to seal peripheral interface between first substrate and second substrate (Step **316**). The method continues with other steps (Step **318**) to complete the solar cell panel.

The above sequence of steps provide a method for assembling a solar cell panel according to an embodiment of the present invention. Alternatively, one or more of the steps may be performed, one or more steps may be eliminated, or one or more steps may be performed in a different sequence depending on the embodiment. One skilled in the art would recognize many other variations, modifications, and alternatives.

FIG. 3B is a simplified flow diagram illustrating a method of assembling a solar cell apparatus according to an embodiment of the present invention. This diagram is merely an example, which should not unduly limit the scope of the claims herein. One of ordinary skill in the art would recognize other variations, modifications, and alternatives. As shown, the method provides a first substrate member (Step **302**). The first substrate member includes a plurality of photovoltaic strips thereon. The method provides a second substrate member (Step **304**) which includes a plurality of optical concentrating elements. The method also includes providing a high emissivity back cover device (Step **305**). The first substrate

member is aligned and couple to the second substrate member (Step 306). A pressure is applied (Step 308). In a specific embodiment, an inner region of the second substrate member (Step 310) is blocked from irradiation while a peripheral region remained exposed (Step 312). The method includes irradiating the exposed peripheral region of the second substrate member (Step 314) and forming a melting region in an interface region between the first substrate member and the second substrate member. The melting region is used to seal peripheral interface between first substrate and second substrate (Step 316). The method continues with other steps (Step 318) to complete the solar cell panel.

The above sequence of steps provide a method for assembling a solar cell panel according to an embodiment of the present invention. Alternatively, one or more of the steps may be performed, one or more steps may be eliminated, or one or more steps may be performed in a different sequence depending on the embodiment. One skilled in the art would recognize many other variations, modifications, and alternatives.

FIG. 4 is a simplified diagram of coupling 400 a back cover member 401 to a concentrator member 402 according to an embodiment of the present invention. This diagram is merely an example, which should not unduly limit the scope of the claims herein. One of ordinary skill in the art would recognize other variations, modifications, and alternatives. As shown in FIG. 4, the back cover member 401 includes, a first peripheral region 404, which has a protruding structure 406 and a first flat region in a portion of the first peripheral region. Also shown in FIG. 4, the concentrator member includes a second peripheral region 408, which has an indent structure 410 and a second flat region in a portion of the second peripheral region. In a specific embodiment, the protruding structure and the indent structure provides a tongue and groove mechanism to couple the back cover member and the concentrator member. Additionally, the back cover member and the concentrator member may be aligned using the tongue and groove mechanism in a specific embodiment, the protruding structure 406 of the back cover member is aligned to a second peripheral region 408 of the concentrator member such that each of the plurality of photovoltaic strips is coupled to a concentrator element in the concentrator member. As shown in FIG. 4, the coupled substrate member includes an interface region 412 formed from the first peripheral region and the second peripheral region. In a specific embodiment, the protruding structure 410 has a semi-circular cross section. For example, the protruding structure 410 has a diameter of about $19/1000$ of an inch or less and runs along the second peripheral region of the concentrator member. Alternatively, the protruding structure can be any shape, for example, the cross section can be rectangular, or other polygon shapes. The indent structure can be shaped accordingly to mate with the protruding structure. Of course there can be other variations, modifications, and alternatives.

Optionally, before coupling, the interface region may be subjected to a cleaning process to remove any material that may affect sealing of the substrate members. The cleaning process can include using a suitable solvents or a combination of solvents followed by drying. Alternatively the cleaning process may include a plasma cleaning, or a blasting process to remove undesirable material. Of course there can be other variations, modifications, and alternatives.

In a specific embodiment, after aligning the concentrator member to the back cover member, a force is provided to mechanically couple the aligned concentrator member to the back cover member. The force may be provided by a plate, fluid pressure, a clamp or any other suitable techniques. Further details of the applied force can be found through the

present specification and particularly below. Of course there can be other variations, modifications, and alternatives.

FIG. 5-7 are simplified diagrams of joining the concentrator member and back cover member and to seal them together using an electromagnetic radiation according to an embodiment of the present invention. These diagrams are merely examples, which should not unduly limit the scope of the claims herein. One of ordinary skill in the art would recognize other variations, modifications, and alternatives. As shown in FIG. 5, a stage member including a waveguide device 504 is provided. The waveguide device includes an inner waveguide 506, an outer waveguide 508, and an opening region 510. The waveguide device also includes an upper surface region 512 and a back surface region 514. In a specific embodiment, the electromagnetic radiation is allowed to pass through the opening region of the waveguide device and blocked by the inner waveguide region and the outer waveguide region. In a specific embodiment, the opening region includes a straight face region 518 and an oblique face region 520. In a specific embodiment, the straight face region may be a flat surface. The straight face region may also be a curved surface that is concave or convex depending on the application. In a specific embodiment, the oblique face region may be a flat surface. Alternatively, the oblique face region may be a curved surface depending upon the application. The oblique face region and the straight face region allow for a maximum transmission of the electromagnetic radiation through the opening region. The waveguide device is preferably made of a highly reflective material at least in the straight face region and the oblique face region. In a specific embodiment, the waveguide device is made of a gold plated alloy. For example, the alloy may be steel and/or other metal materials. The waveguide device is configured to allow for a concentration of the electromagnetic radiation to concentrate at a weld region 516 in the peripheral region in a specific embodiment. A top view of the waveguide device is shown in FIG. 5A. Of course there can be other variations, modifications, and alternatives.

In a specific embodiment, the waveguide device is provided overlying the aperture region of the concentrator member. In a specific embodiment, a force 522 is applied on the front surface region of the waveguide device to mechanically couple the concentrator member to the back cover member to form the peripheral region as also shown in FIG. 5. In a specific embodiment, the mechanical force can be provided using air pressure or a weight such as a cylinder providing a pressure ranging from about 100 psi to about 200 psi. Other means of mechanical forces, such as an air pressure, may also be used. Of course there can be other variations, modifications, and alternatives.

Referring to FIG. 6, the coupled concentrator member and the back cover member is irradiated using an electromagnetic radiation 602. The electromagnetic radiation may be provided using a energy source such as a laser source or a flash lamp or other suitable energy source. In a specific embodiment, the electromagnetic radiation may be provided using a laser (e.g., laser diode, tunable dye, etc.) having a suitable wavelength range and providing a suitable power range. In a preferred embodiment, the electromagnetic radiation is provided for a time period of about eight seconds or less and preferably 1-4 seconds. Effectively, the electromagnetic radiation traverses through the entire exposed peripheral region of at least the concentrator member of the coupled substrate within the entire time period and provides energy to cause a melt region 608 in the interface region while the inner region is blocked from the electromagnetic radiation.

In a specific embodiment, the electromagnetic radiation and/or laser energy is guided using one or more fiber optics

606 from a source 604 and through the opening region of the waveguide device to the peripheral region of the coupled substrate to provide energy to cause the melt region in the peripheral region. For example, the source 604 is a laser source. The laser source provides pulses of energy and the one or more fiber optics are allowed to translate above the opening region of the waveguide device to provide energy to cause the melt region in the interface region of the coupled substrate members in a specific embodiment. As merely an example, the electromagnetic radiation can be derived from Laser IRAM assembly systems Models 200 and 300 manufactured by Branson Ultrasonics Corp., 41 Eagle Rd., Danbury, Conn. 06813-1961, USA. Of course there can be other variations, modifications, and alternatives.

In a specific embodiment, the light/laser radiation traverses through the entire thickness of the concentrator member, which can be a polymer component transmissive to light. The energy is absorbed at least by the back cover member at the interface region to cause a melt region 608 in the interface region. In a specific embodiment, the back cover member is made of a light absorbing material at least in the second peripheral region. The light absorbing material absorbs irradiation energy traversing at least the first peripheral region of the concentrator element, which is transparent, to cause heating and to form the melting region in the interface region. In a specific embodiment, the light absorbing material can also be a light blocking material or include each of these characteristics. In an alternative embodiment, the light absorbing material may be provided in the interface region to absorb the irradiation energy to cause heating and forming the melt region in the interface region. In a specific embodiment, the concentrator element can be made of an acrylic material characterized by a high transmissivity to light. In a specific embodiment, the back cover member can be a polymer having a high emmissivity. As merely an example, the back cover member can be an acrylic material. Alternatively, the back cover member can be a polycarbonate material. In the example of an acrylic concentrator element and a polycarbonate back cover, the irradiation energy heats the interface region to a temperature of about 110 Degree Celsius to about 115 Degree Celsius to cause the melt region configured to be light absorbing. In a specific embodiment at least 90% of the energy is transmitted through the first peripheral region of the concentrator member and absorbed by the back cover member to cause the melt region as shown by the relationship:

$$E = E_C + E_B,$$

where E is the energy provided by the electromagnetic radiation,

E_C is the energy absorbed by the concentrator member in the peripheral region, and

E_B is the energy absorbed by the back cover member in the peripheral region.

As shown, E_B ranges from 90% to 95% of E, that is 90% to 95% of the energy is transmitted through the concentrator member and absorbed by the back cover member to cause the melt region in the peripheral region. Of course there can be other variations, modifications, and alternatives.

In a specific embodiment, the melt region forms a seal region 702 for the back cover member and the concentrator member. FIG. 7 is a simplified side-view diagram of a concentrator member and a back cover member according to an embodiment of the present invention. This diagram is merely an example, which should not unduly limit the scope of the claims herein. One of ordinary skill in the art would recognize other variations, modifications, and alternatives. In a specific embodiment, the melt region forms a seal region 702 for the

back cover member and the concentrator member. A more detailed diagram of the seal region is also shown. In a specific embodiment, the seal region has a width 704 of about 50 um or less and can include a protruded region 706. In a specific embodiment, the seal region provided is free of contaminations such as particulates or chemical species as may occur by other means. The seal region maintains the photovoltaic strips and electrical conducting element in a desired controlled environment and provides protection from elements such as moisture and others. Of course there can be other variations, modifications, and alternatives.

Effectively, the irradiation energy causes a temperature gradient within the interface region. Taking acrylic as the material for the concentrator member and polycarbonate as the material for the back cover member as an example. The polycarbonate is designed to be light absorbing and the acrylic is designed to be transmissive. The energy transmitted through the first peripheral region of the concentrator member provides heat energy to increase the temperature of the interface region to about 105 Degree Celsius to about 120 Degree Celsius to cause the melt region. In a specific embodiment, the temperature gradient is provided within a vertical distance in the interface region as illustrated in a simplified plot 800 in FIG. 8. As shown, the temperature is provided on vertical axis and the vertical distance is provided on the horizontal axis. The temperature gradient is essentially provided within a vertical distance 701 as shown. In a specific embodiment, the temperature gradient is provided within a vertical distance of about 40 micron to about 50 micron in the vertical direction. That is the thermal energy is provided within vertical distance 801 for a time period to form the melt region in a specific embodiment. The time period is about eight seconds or less and preferably 4-6 seconds in a specific embodiment. Of course there can be other variations, modifications, and alternatives.

It is also understood that the examples and embodiments described herein are for illustrative purposes only and that various modifications or changes in light thereof will be suggested to persons skilled in the art and are to be included within the spirit and purview of this application and scope of the appended claims.

What is claimed is:

1. A method for fabricating solar cells for a solar panel, the method comprising:
 - providing a first substrate member comprising a plurality of photovoltaic strips thereon;
 - providing an optical elastomer material overlying a portion of the first substrate member;
 - aligning a second substrate member comprising a plurality of optical concentrating elements thereon such that at least one of the optical concentrating elements is operably coupled to at least one of the plurality of photovoltaic strips, wherein the second substrate member comprises an aperture surface region and an exit surface region;
 - coupling the first substrate member directly to the second substrate member to form an interface region along a first peripheral region of the first substrate member and along a second peripheral region of the second substrate member;
 - blocking an inner region of the aperture surface region of the second substrate member while exposing the peripheral region of the aperture surface region of the second substrate member; and
 - irradiating an entirety of the second peripheral region of the second substrate member using an electromagnetic

15

radiation to cause a melt region and seal the interface region between the second substrate and the first substrate.

2. The method of claim 1 wherein the coupling further comprises applying a mechanical force to increase pressure at the interface region between the first substrate and the second substrate to maintain the first substrate member and the second substrate member mated together during irradiating.

3. The method of claim 1 wherein the irradiation provides a temperature gradient in a vertical distance of less than 50 μm within the interface region.

4. The method of claim 2 wherein the mechanical force provides a pressure of about 150 psi and greater.

5. The method of claim 1 wherein each of the solar cells is provided in a panel.

6. The method of claim 1 wherein the second substrate member is optically transparent.

7. The method of claim 1 wherein the electromagnetic radiation comprises a flash lamp or a laser source.

8. The method of claim 1 wherein the irradiating is provided for a time period of eight seconds and less.

9. The method of claim 1 further comprising cleaning the interface region before coupling the first substrate member to the second substrate member.

10. The method of claim 1 wherein the interface region has one or more voids of a dimension of $\frac{1}{1000}$ of an inch or less before the irradiating.

11. The method of claim 1 wherein the first substrate member comprises a polymer bearing material, a non-conductive material, or a multi-layer material.

12. The method of claim 1 wherein the electromagnetic irradiation traverses through an entirety of the second peripheral region to cause the melt region at the interface region to cause sealing of the interface region between the first substrate member and the second substrate member.

13. A method for fabricating a solar cell free and separate from a solar panel, the method comprising:

providing a first substrate member comprising a plurality of photovoltaic strips thereon, the first substrate member having a first peripheral region, the first peripheral region including a first flat region and a first structure region, the first structure region including a protruding structure;

providing an optical elastomer material overlying a portion of the first substrate member;

providing a second substrate member having a second peripheral region, the second peripheral region including a second flat region and a second structure region, the second structure region including an indent structure;

aligning the second substrate member comprising a plurality of optical concentrating elements thereon such that the first flat region of the first substrate mates with the second flat region of the second substrate, the second substrate member comprising an aperture surface region and an exit surface region; and

coupling the first substrate member directly to the second substrate member to form a sealing region between the first peripheral region of the first substrate member and the second peripheral region of the second substrate

16

member and to engage the first structure region of the first substrate to the second structure region of the second substrate.

14. The method of claim 13 wherein the protruding structure is mated to the indent structure using a tongue and groove mechanism.

15. The method of claim 13 wherein the plurality of photovoltaic strips are provided within a respective plurality of recessed regions on the first substrate member.

16. The method of claim 13 wherein the first substrate member comprises a polymer bearing material, a non-conductive material, or a multilayered material.

17. The method of claim 13 wherein each of the photovoltaic strips comprises a silicon bearing material.

18. The method of claim 13 wherein the first substrate member is characterized by a high emissivity at least in the first peripheral region.

19. The method of claim 13 wherein the coupling comprises irradiating an entirety of the second peripheral region of the second substrate member with electromagnetic radiation to cause a melt region and seal the sealing region between the second substrate and the first substrate.

20. The method of claim 19 wherein the electromagnetic radiation comprises a flash lamp or a laser source.

21. The method of claim 19 wherein the electromagnetic radiation is substantially absorbed by the first substrate member in the interface region to cause the melt region.

22. The method of claim 13 wherein the first flat region and the first structure have lengths of about 30 microns to about 100 microns and the second flat region and the second structure have lengths of about 30 microns to about 100 microns.

23. The method of claim 13 wherein the coupling comprises applying a mechanical force to increase pressure at the interface region between the first substrate and the second substrate to maintain the first substrate member and the second substrate member mated together during irradiating.

24. The method of claim 23 wherein the mechanical force provides a pressure of about 150 psi and greater.

25. A method for fabricating a solar cell free and separate from a solar panel, the method comprising:

providing a first substrate member comprising a plurality of photovoltaic strips configured as an assembly thereon, the first substrate member having a first peripheral region, the first peripheral region including a protruding structure;

providing an optical elastomer material overlying a portion of the first substrate member;

providing a second substrate member having a second peripheral region, the second peripheral region including an indent structure;

aligning the second substrate member comprising a plurality of optical concentrating elements thereon such that the protruding structure of the first substrate mates with the indent structure of the second substrate; and

coupling the first substrate member directly to the second substrate member to form a sealing region between the first peripheral region of the first substrate member and the second peripheral region of the second substrate member.

* * * * *