



(86) Date de dépôt PCT/PCT Filing Date: 2001/12/21  
 (87) Date publication PCT/PCT Publication Date: 2002/07/04  
 (45) Date de délivrance/Issue Date: 2010/02/02  
 (85) Entrée phase nationale/National Entry: 2003/06/09  
 (86) N° demande PCT/PCT Application No.: GB 2001/005707  
 (87) N° publication PCT/PCT Publication No.: 2002/051476  
 (30) Priorité/Priority: 2000/12/22 (GB0031466.6)

(51) Cl.Int./Int.Cl. *A61M 5/24* (2006.01),  
*A61M 5/142* (2006.01), *A61M 5/145* (2006.01),  
*A61M 5/172* (2006.01), *A61M 5/315* (2006.01)

(72) Inventeurs/Inventors:  
 LANGLEY, CHRISTOPHER NIGEL, GB;  
 DAY, SHANE ALISTAIR, GB;  
 VEASEY, ROBERT FREDERICK, GB;  
 WOOLSTON, ROBERT, GB

(73) Propriétaire/Owner:  
 DCA DESIGN INTERNATIONAL LIMITED, GB

(74) Agent: BERESKIN & PARR LLP/S.E.N.C.R.L.,S.R.L.

(54) Titre : INJECTEUR AU FORMAT STYLO AVEC UNITE DE COMMANDE ELECTRONIQUE  
 (54) Title: PEN-TYPE INJECTOR HAVING AN ELECTRONIC CONTROL UNIT

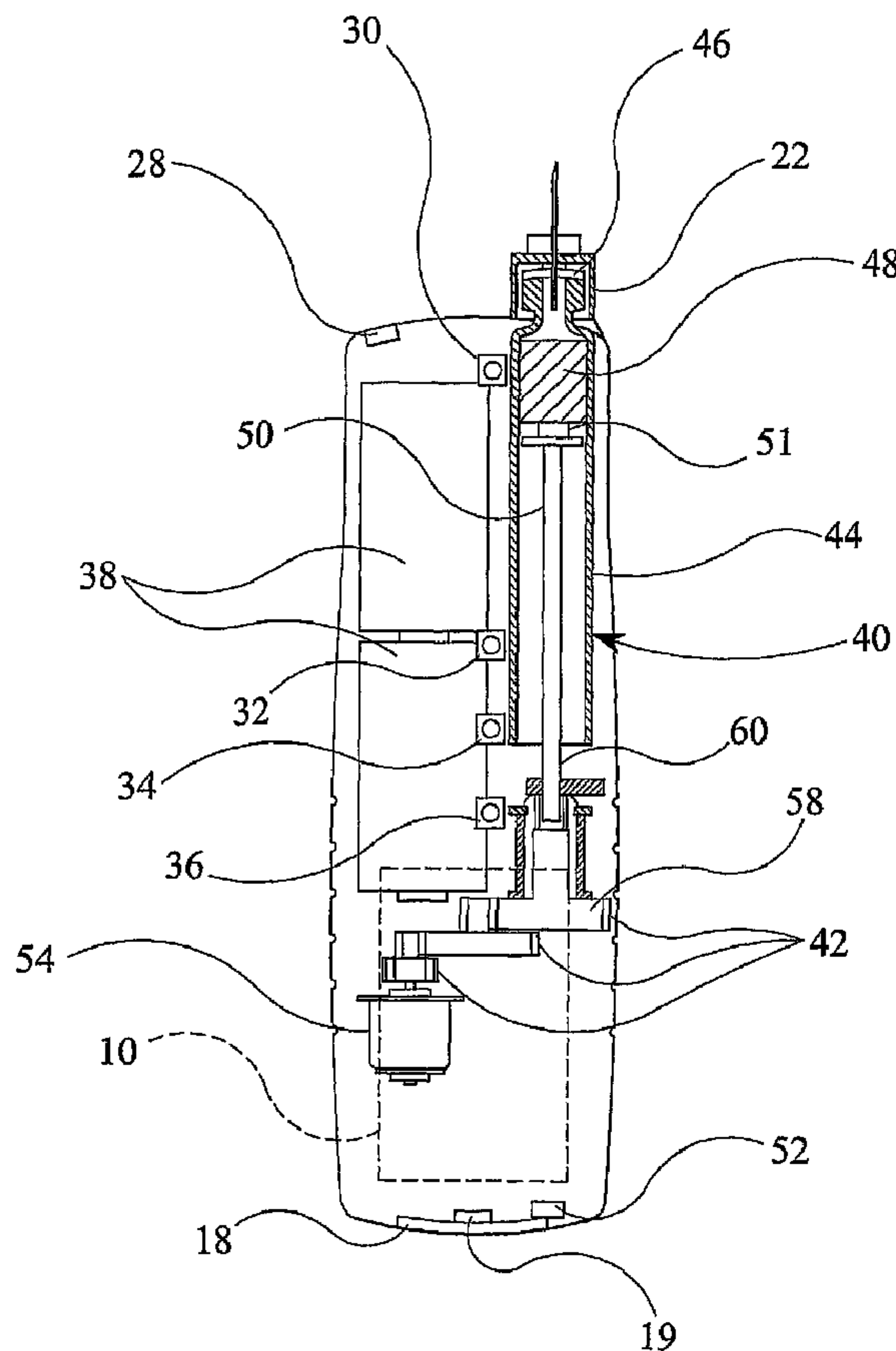

(57) Abrégé/Abstract:

An injection device for injection of a medicament from a medicament cartridge, the medicament cartridge (40) having a bung (48) displaceable within the medicament cartridge (40) to cause medicament to be expelled from the medicament cartridge (40) is

(57) **Abrégé(suite)/Abstract(continued):**

disclosed. The injection device comprises a drive mechanism (42) for selectively acting on the bung (48) to dispense the medicament from the medicament cartridge (40) and an electronic control unit for controlling operation of the drive mechanism (42). Under the control of the electronic control unit the drive mechanism (42) initially acts at first speed and at a second speed thereafter.

## (12) INTERNATIONAL APPLICATION PUBLISHED UNDER THE PATENT COOPERATION TREATY (PCT)

(19) World Intellectual Property Organization  
International Bureau(43) International Publication Date  
4 July 2002 (04.07.2002)

PCT

(10) International Publication Number  
**WO 02/051476 A1**

- (51) International Patent Classification<sup>7</sup>: A61M 5/24, 5/315, 5/172, 5/145, 5/142
- (21) International Application Number: PCT/GB01/05707
- (22) International Filing Date:  
21 December 2001 (21.12.2001)
- (25) Filing Language: English
- (26) Publication Language: English
- (30) Priority Data:  
0031466.6 22 December 2000 (22.12.2000) GB
- (71) Applicant (for all designated States except US): DCA DESIGN INTERNATIONAL LIMITED [GB/GB]; 19 Church Street, Warwick CV34 4AB (GB).
- (72) Inventors; and  
(75) Inventors/Applicants (for US only): LANGLEY, Christopher, Nigel [GB/GB]; 120 Leicester Lane, Leamington Spa, Warwickshire CV32 7HH (GB). DAY, Shane, Alistair [GB/GB]; 9 Brese Avenue, Warwick CV34 5TS (GB). VEASEY, Robert, Frederick [GB/GB]; 35 Hitchman Road, Leamington Spa CV31 1QH (GB). WOOLSTON, Robert [GB/GB]; 3 Chestnut Grove, Moreton Morrell, Warwick CV35 9DG (GB).
- (74) Agents: MOFFAT, John, Andrew et al.; Lewis & Taylor, 5 The Quadrant, Coventry CV1 2EL (GB).
- (81) Designated States (national): AE, AG, AL, AM, AT, AU, AZ, BA, BB, BG, BR, BY, BZ, CA, CH, CN, CO, CR, CU, CZ, DE, DK, DM, DZ, EC, EE, ES, FI, GB, GD, GE, GH, GM, HR, HU, ID, IL, IN, IS, JP, KE, KG, KP, KR, KZ, LC, LK, LR, LS, LT, LU, LV, MA, MD, MG, MK, MN, MW, MX, MZ, NO, NZ, OM, PH, PL, PT, RO, RU, SD, SE, SG,

[Continued on next page]

(54) Title: PEN-TYPE INJECTOR HAVING AN ELECTRONIC CONTROL UNIT

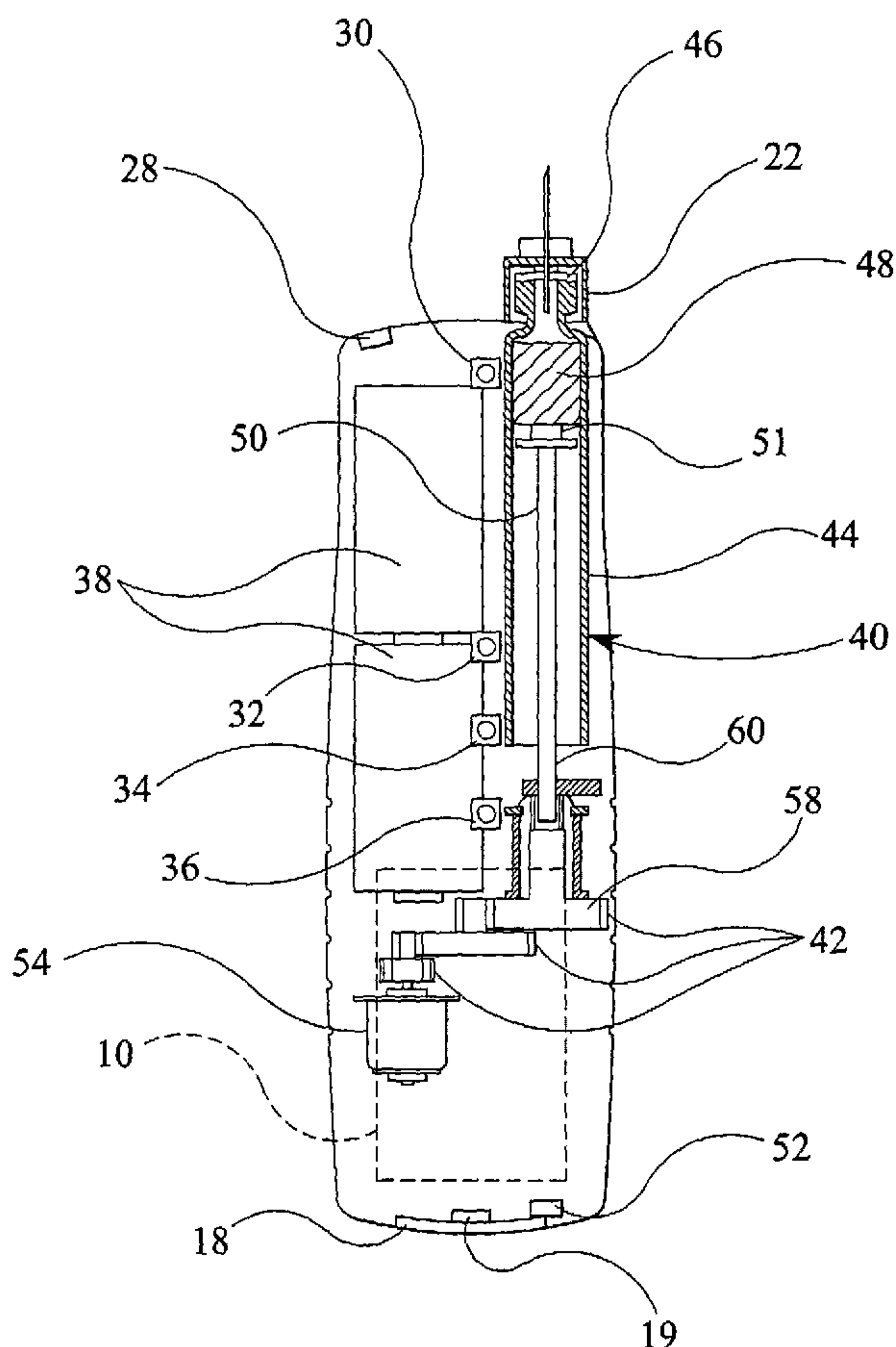

(57) Abstract: An injection device for injection of a medicament from a medicament cartridge, the medicament cartridge (40) having a bung (48) displaceable within the medicament cartridge (40) to cause medicament to be expelled from the medicament cartridge (40) is disclosed. The injection device comprises a drive mechanism (42) for selectively acting on the bung (48) to dispense the medicament from the medicament cartridge (40) and an electronic control unit for controlling operation of the drive mechanism (42). Under the control of the electronic control unit the drive mechanism (42) initially acts at first speed and at a second speed thereafter.

WO 02/051476 A1

**WO 02/051476 A1**

SI, SK, SL, TJ, TM, TN, TR, TT, TZ, UA, UG, US, UZ,  
VN, YU, ZA, ZM, ZW.

**(84) Designated States (regional):** ARIPO patent (GH, GM, KE, LS, MW, MZ, SD, SL, SZ, TZ, UG, ZM, ZW), Eurasian patent (AM, AZ, BY, KG, KZ, MD, RU, TJ, TM), European patent (AT, BE, CH, CY, DE, DK, ES, FI, FR, GB, GR, IE, IT, LU, MC, NL, PT, SE, TR), OAPI patent (BF, BJ, CF, CG, CI, CM, GA, GN, GQ, GW, ML, MR, NE, SN, TD, TG).

**Declarations under Rule 4.17:**

— *of inventorship (Rule 4.17(iv)) for US only*

— *of inventorship (Rule 4.17(iv)) for US only*  
 — *of inventorship (Rule 4.17(iv)) for US only*  
 — *of inventorship (Rule 4.17(iv)) for US only*

**Published:**

— *with international search report*  
 — *before the expiration of the time limit for amending the claims and to be republished in the event of receipt of amendments*

*For two-letter codes and other abbreviations, refer to the "Guidance Notes on Codes and Abbreviations" appearing at the beginning of each regular issue of the PCT Gazette.*

## PEN-TYPE INJECTOR HAVING AN ELECTRONIC CONTROL UNIT

The present invention relates to improvements in an injection device, and in particular to improvements in a portable injection device for dispensing controlled quantities of a  
5 medicament.

Typically such injection devices are used by those suffering from diabetes to administer a dose of insulin or insulin-type medicine to themselves. It will be understood that such injection devices are suitable for the injection of other medicines.

10

At one time, such doses were administered by use of a disposable syringe; the syringe first being filled from a separate phial or other container and then used to inject the dose. However, there were a number of difficulties in such an arrangement. In particular, such an arrangement was not suitable for the infirm. For others, the social stigma associated  
15 with such syringes made their public use problematic.

To overcome these difficulties a number of so-called pen-type injectors have been developed. These devices are small, being capable of being carried in a jacket pocket or the like and allow a number of doses to be obtained from a cartridge or ampoule  
20 contained within the injector. The present invention has particular application to such pen-type injectors.

While such pen-type injectors are a considerable improvement upon disposable hypodermic syringes, problems nevertheless remain. It is an advantage of the present  
25 invention that it eliminates, or at least substantially reduces such problems. The present invention also provides for improved ease of use and improved interaction with a user.

The invention will now be described, by way of example only, with reference to the accompanying drawings; in which:-

Figure 1 shows a plan view of a pen-type injector in accordance with the present invention;

Figure 2 shows a similar view to Figure 1 with an end cap of the injector omitted;

Figure 3 shows a cross-sectional view of the injector of Figures 1 and 2; and

5 Figure 3A shows a view similar to that of Figure 3 with a filled cartridge in the injector.

Referring first to Figures 1 to 3, there can be seen a pen-type injector 2 in accordance with the present invention. The injector 2 comprises a main housing 4 to which is releasably secured an end cap or cover 6.

10

At a first end of the main housing 4 there is provided a control panel region 8. This region includes a display panel 10, typically a LCD display, and a first dose button 12 and a second dose button 14, the first and second dose buttons being operated to increase or decrease a dose of medicament to be delivered. The control panel region 10 in the  
15 illustrated embodiment also includes an arm button 16.

At the first end of the main housing there is also provided a dispense button 18.

Preferably, when not depressed, the dispense button 18 is flush with the main housing 4.

20

Along a longitudinal axis of the injector 2, to each side of the control panel region 10 are provided a number of grooves or recesses 20. These aid in the gripping of the injector 2 by a user.

25

At a second end of the main housing 4 a needle unit 22 is releasably secured to the main housing. The second end of the main housing 4 is also provided with a shaped portion 24.

30

In use a cartridge 40 or ampoule of medicament is stored in the housing 4 behind the shaped portion 24. For preference, the shaped portion is transparent to permit the cartridge 40 to be seen by a user.

A primer button 26 is also provided on the second end of the housing 4. It will be understood that when the end cap 6 is in place over the second end of the housing, it will not be possible inadvertently to depress the primer button 26 or to be pricked by the needle unit 22. A cover detection switch 28 may also be included at the second end of  
5 the main housing 4 to detect whether the end cap or cover 6 is in place or not.

In Figure 3, there can be seen a priming contact 30, an arm contact 32, a first dose contact 34 and a second dose contact 36 corresponding to the respective buttons. A dispense contact 19 corresponding to the dispense button 18 is also shown.

10

With reference to Figure 3 it may be seen that there is provided a suitable location for a power source 38 such as a battery or batteries. There is also a suitable region in which a cartridge 40 or ampoule of medicament is to be located. This region may be accessed by way of the removable shaped portion 24 of the main housing 4 to allow for replacement  
15 of the cartridge 40 or ampoule as required by the user.

In a third region of the main housing 4 there is provided a drive mechanism 42 which operates from the power source 38 and acts upon the cartridge 40 or ampoule of  
20 medicament.

20

The cartridge 40 or ampoule comprises a container 44 or sleeve closed at one end by a cover 46 at a head end thereof, and sealed at the other by a movable bung 48 or stopper. When in position, the needle unit 22 pierces the cover 46 and movement of the bung 48 towards the cover 46 will cause the medicament contained within the cartridge 40 or  
25 ampoule to be expelled. The cartridge may be a 3ml cartridge in accordance with ISO/FDIS 11608 Part 3, or any other suitable cartridge to suit the injector.

Movement of the bung 48 or stopper is caused by movement of a piston or plunger 50 forming a part of the drive mechanism 42. The piston or plunger 50 is movable between  
30 a first fully withdrawn position (not shown) which allows for the replacement of the

cartridge 40 or ampoule and a second fully extended portion in which as much medicament as possible has been expelled from the cartridge 40 or ampoule. An end stop switch 52 may be provided in the main housing 4 to detect when the piston 50 is in the fully withdrawn position. Tripping of the switch end stop 52 may release a catch or other fastening device to allow access to the main housing 4 for replacement of the cartridge 40.

The drive mechanism 42 is operated by a motor 54 under the control of an electronic control unit (not shown). The motor 54 should be reversible in order to allow the piston 50 to be moved between the first and second positions. In Figure 3, the motor 54 can be seen to drive the piston 50 by way of a gear train 42, such that rotation of a third rotor 58 causes the piston 50 to be moved in relation to the third rotor 58.

Preferably, the user can feel the vibration of the motor 54 and the associated drive mechanism 42 and/or hear them in operation. In this way an added degree of confidence in the fact of the operation of the injector 2 is provided to the user.

The functionality of a pen-type injector in accordance with the present invention will now be described, in particular with reference to Figures 1, 2 and 3.

20

The injector 2 is provided with an electronic control unit. The electronic control unit is coupled both to the drive mechanism and a user interface. The user interface includes the display panel 10 as well as the user operable buttons (and associated contacts). The electronic control unit is microprocessor based. Either volatile or non-volatile memory may be used for storage of 'dose history' and patient specific information.

25

The electronic control unit is preferably powered from the injector power source 38.

The injector 2 preferably also includes a port for communication between the electronic control unit and an external apparatus such as a personal computer.

30



The injector 2 also has a priming detection facility, (such as a tilt switch or accelerometer) to identify when the injector 2 is inverted. On detection of an inverted position (needle up) the injector 2 will automatically change state to be ready for priming.

5 Priming may be initiated by depression of the primer button 26 to cause a fixed small dispense action. The electronic control unit may cause a speaker to sound when the primer button 26 is depressed.

10 The primer button 26 is inactive at all other times. When the primer button 26 is active, all other buttons in the control panel region are inactive, that is those buttons which are to be used to set or dispense a dose.

The electronic control unit may cause a speaker to sound when the arm button 16 is depressed for a sufficient period of time to provide audible feedback for the user.

15

The function of the arm button 16 is to make the dispense button 18 active. The arm button is preferably held down for a predetermined period of time before the injector 2 becomes armed. The armed status may additionally be shown on the display panel 10. The functionality of the arm button is preferably linked to the cover detection switch 28 such that the arm button 16 will only function to arm the injector 2 when the cover 6 is not present.

20

25 Additionally, in a preferred embodiment, a clock within the electronic control unit will detect whether the dispense button 18 has been pressed within a specified time interval following arming of the injector 2. If the dispense button 18 has not been depressed within the specified time interval the electronic control unit will disarm the injector 2.

Alternatively, if the arm button is depressed a second time within a predetermined time period by the user, the injector will be disabled.

30

In an alternative embodiment, the dose button 18 may function as both a prime button and the dose button. When the priming detector is actuated, by the injector 2 being oriented needle up, the dispense button 18 would change function to that of the prime button of the previous embodiment.

5

The buttons of the injector 2 are preferably tactile in nature to provide sensory feedback to the user.

10

The display panel 10 is typically an LCD display and will provide alphanumeric and graphical information relating to the operation of the device. The display panel 10 preferably indicates the selected dose quantity, the previous dose quantity and the time elapsed since the previous dose was administered. Typically, the time elapsed since the previous dose is limited to a time period within the preceding 48 hours, though other time periods are possible.

15

Additional information which may be displayed includes:

20

- that the injector is armed and ready to dispense (graphical)
- that the injector is dispensing (graphical)
- that the injector has dispensed the selected dose and that a user should wait before removing the needle from their body
- that this waiting period has elapsed
- the dose history, typically for the last 48 hours, in terms of the dosage taken and the elapsed time between doses
- the quantity of medicament remaining in the cartridge, preferably in terms of dosage units of the medicament.
- that the device is in the priming position (either in addition to or instead of the acoustic indication noted above)
- the speaker volume setting, for example high, low or muted.

25

- that the injector is nearing the end of its life (for example a battery power level indication - graphical or countdown in terms of the number of days or complete operating cycles to a predetermined expiry of the product life - alphanumeric).

- that the needle is probably blocked

5 - that replacement of the cartridge 40 is in progress

- that the dose selected is the maximum available in the cartridge 40

- that the maximum dose available is less than the dose expected.

10 The display panel 10 may offer a user a choice of language options as appropriate for the market and/or user. The text displayed may include that noted above and/or further information. The language option may be pre-programmed or selectable by a user. The user may preferably select the language option by means of a menu provided on the display panel 10.

15 The currently selected dose value, the previously used dose value and the time (in hours) since the previous dose was dispensed, may all be shown clearly at the same time, in large, easy-to-read characters on the display. Preferably, the display is also provided with a backlight.

20 The display 10 preferably provides a graphical indication that the selected dose is being dispensed. This may be achieved, for example, as either an animated graphic or a countdown (or a combination of both).

25 The control buttons have a number of functions. The dose buttons 12,14 allow a user to select a desired dosage. The dose arm button 16 allows a user to confirm selection of a desired dosage. The first dose button can increment the dosage level and the second dose button can decrement the dosage level. The dose dialling buttons 12,14 may be pressed down (and held for a short time, 1-2 seconds) to re-set a dose value to zero. The user can then dial up (or down) in single (or half) increments.

The dose dialling buttons 12,14 are intended to be pressed once for a single (or half) increment in the selected dose value. In an alternative embodiment, pressing and holding one of the buttons will cause the dose value to start to scroll (up or down) in order to change the dose size more rapidly.

5

The dispense button 18 allows a user to initiate dispensing of the dosage. The primer button 26 dispenses a unit of dosage from the cartridge 40. Thus, if any air is trapped in the injector 2 this can be expelled by use of the primer button 26. A door release catch is provided to allow access to the cartridge 40.

10

The injector 2 may also be provided with an audible alarm, such as a piezo-electric sounder or an electronically-operated sounder. The device may have a switch or means of setting the volume level of the sounder and/or to turn it off. This may be used to provide an acoustic confirmation of depression of one or more of the buttons, as an alarm indicator to warn the user that there is a limited quantity of medicament in the cartridge 15 40, as an alarm indicator to warn a user that the injector is nearing the end of its life (battery drainage indicator), to indicate that the desired dosage has been delivered and that a predetermined time has elapsed since completion of a dispense operation and a user is now free to withdraw the needle and/or other conditions as may be required. The 20 acoustic signal may be provided in addition to a visual signal provided on the display panel 10 and in addition to any feedback provided by the tactile nature of the buttons.

Since the cartridge 40 is of a standard size, each cartridge 40 will be emptied by an identical travel of the plunger driven by the drive mechanism. Once the plunger 50 is in 25 the fully extended position, the cartridge 40 is known to be empty and an indication of this will be provided to the user.

When the door release catch is operated for the emptied cartridge 40 to be removed the drive mechanism 42 is operated to reverse a lead screw 60 to withdraw the plunger 50

until the lead screw 60 strikes the end stop switch 52 which is provided at a known reference point.

When a new cartridge 40 is detected, for example by way of a contact switch (not shown), and the door release catch closed, the electronic control unit advances the lead screw 60 until the plunger 50 strikes the cartridge bung 48. This may conveniently be done by fitting a micro-switch 51, such as a dome contact switch to a free end of the plunger 50.

Since the exact position of the bung 48 can be calculated with reference to the rear end stop 52, a number of units of medicament stored within the cartridge 40 can be determined. Thus a half empty or incorrectly filled cartridge 40 may be used with the injector 2 of the present invention. The electronic control unit having determined the number of units stored within the cartridge preferably will not allow a dosage larger than that remaining to be dialled up for dispense.

Alternatively, user interface software as part of the electronic control unit can aid the user to split the required dose across a cartridge changeover. For example, if the user is due to take a thirty unit dose but only twenty units remain in the injector 2, then the user can dispense the twenty units, replace the cartridge 40 and the injector 2 will automatically offer the user ten units as the 'outstanding balance' from the first dose. If the user does not take the 'outstanding balance' (or other dose size) within a prescribed time, then the injector 2 will revert to the normal display status. In such a case, the injector history may record a 'split dose' as a single dose (being the total of the split doses) so long as the doses are taken within a prescribed time. Alternatively, the user may choose to take the first part of the dose and then cancel the second part of the dose rather than rely upon the time out feature described above. This action will be recorded as part of the injector history information.

A 'dose interrupt' function may also be provided for such that the user can stop (and re-start) the dispense action. This may be useful if the injection becomes painful or if the user wishes to select a large dose, but would like to deliver the dose split between two sites on his/her body. In a first embodiment, the dose button is pressed to start, then  
5 pressed to stop, then pressed to re-start, and so on. Alternatively, the dose button may be pressed and held down to dispense, then released to stop, then pressed and held down to re-start.

The drive mechanism 42 preferably operates at a constant speed during dispense.  
10 However, at the start of each new cartridge 40 a slower speed may be appropriate to increase the force available to overcome stiction of the bung 48 in the cartridge 40. Alternatively, the speed of dispense may be controlled to suit the comfort of the user.

In addition, the drive mechanism may be able to operate at a variable speed. In such a  
15 case, the injector 2 will be adapted to detect resistance to dispensing, for example if the medicament, i.e. insulin, is cold it may become more viscous and so provide greater resistance to dispense. The drive mechanism can then slow to deliver more output force and then stop if this has no effect upon the effective dispense action. In other words if, for example, the resistance to dispensing is due a mechanical problem in the injector then  
20 the electronic control unit will switch off the drive mechanism, and thus not dispense, rather than seek to dispense further medicament.

Due to the use of an electromechanical drive, the dispense action is initiated by the user operating a switch. This means that the force required to operate the dispense button can  
25 be optimised for the comfort and ergonomic requirement of users.

The drive mechanism 42 may additionally comprise a 1 bit encoder (for example an inductive transducer mounted at a first stage in the gear train 56) to detect slipping of the motor. Thus, should the drive mechanism 42 become jammed, this can be detected, the  
30 electronic control unit can halt the drive mechanism 42 and indicate to the user that an

error has occurred.

## CLAIMS

1. An injection device for injection of a medicament from a medicament cartridge, the medicament cartridge having a bung displaceable  
5 within the medicament cartridge to cause medicament to be expelled from the medicament cartridge, the injection device comprising a drive mechanism for selectively acting on the bung to dispense the medicament from the medicament cartridge and an electronic control unit for controlling operation of the drive mechanism in which the drive mechanism under the control of the  
10 electronic control unit initially acts at a first speed and at a second speed thereafter, wherein the device further comprises means to detect resistance to dispense, said means providing a resistance to dispense signal to the electronic control unit, in which the drive mechanism, following receipt of the resistance to dispense signal by the electronic control unit, under the control  
15 of the electronic control unit, acts at the second speed, the second speed being slower than the first speed.

2. An injection device according to claim 1, in which when the resistance to dispense signals continue for a predetermined time following the  
20 drive mechanism acting at the second speed, the electronic control unit halts the drive mechanism.

3. A method of dispensing a dose of medicament from a medicament cartridge within an injection device having a drive mechanism for  
25 selectively acting on a bung of the medicament cartridge comprising the steps of causing the drive mechanism to act on the bung at a first speed; and causing the drive mechanism to act on the bung at a second speed thereafter, wherein the first speed is faster than the second speed.

30 4. A method according to claim 3 characterised in that the second speed is controlled by the user of the injection device.



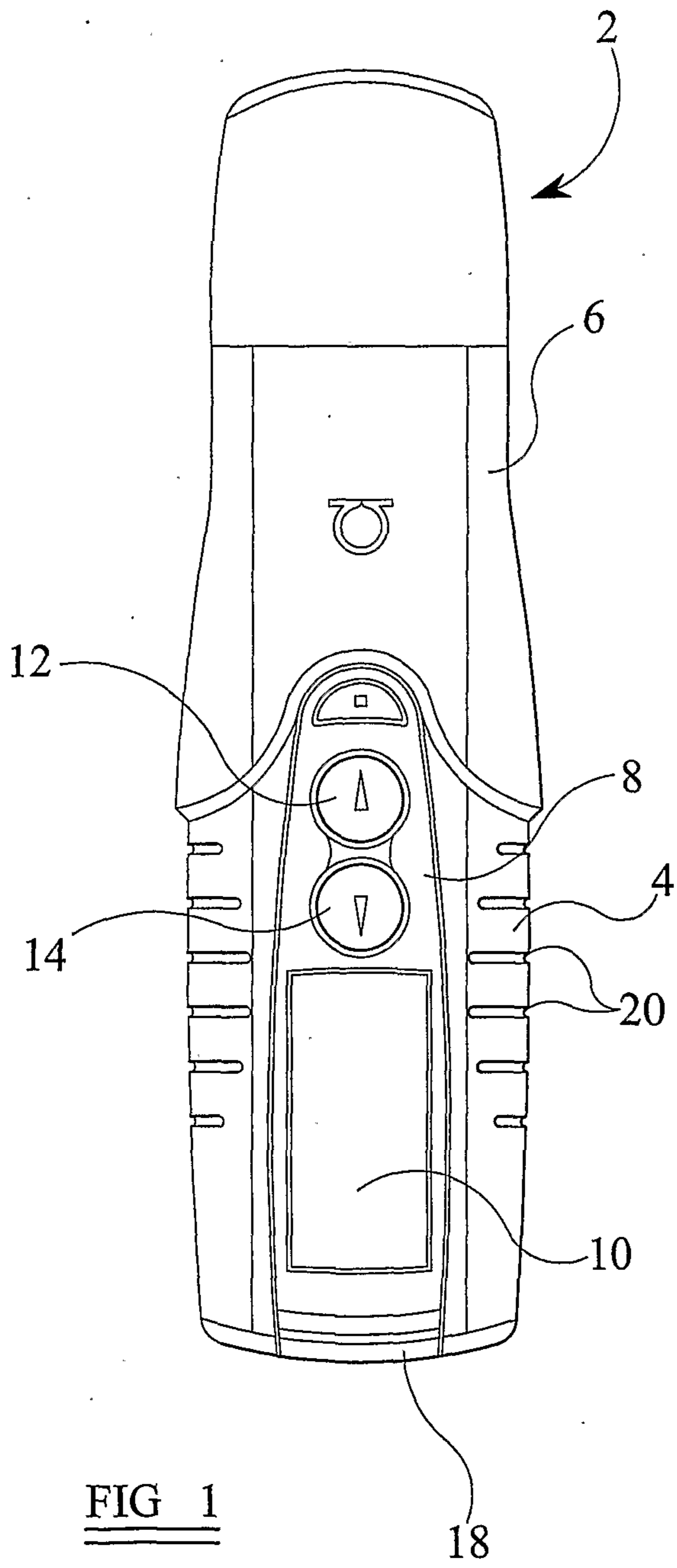

FIG 1

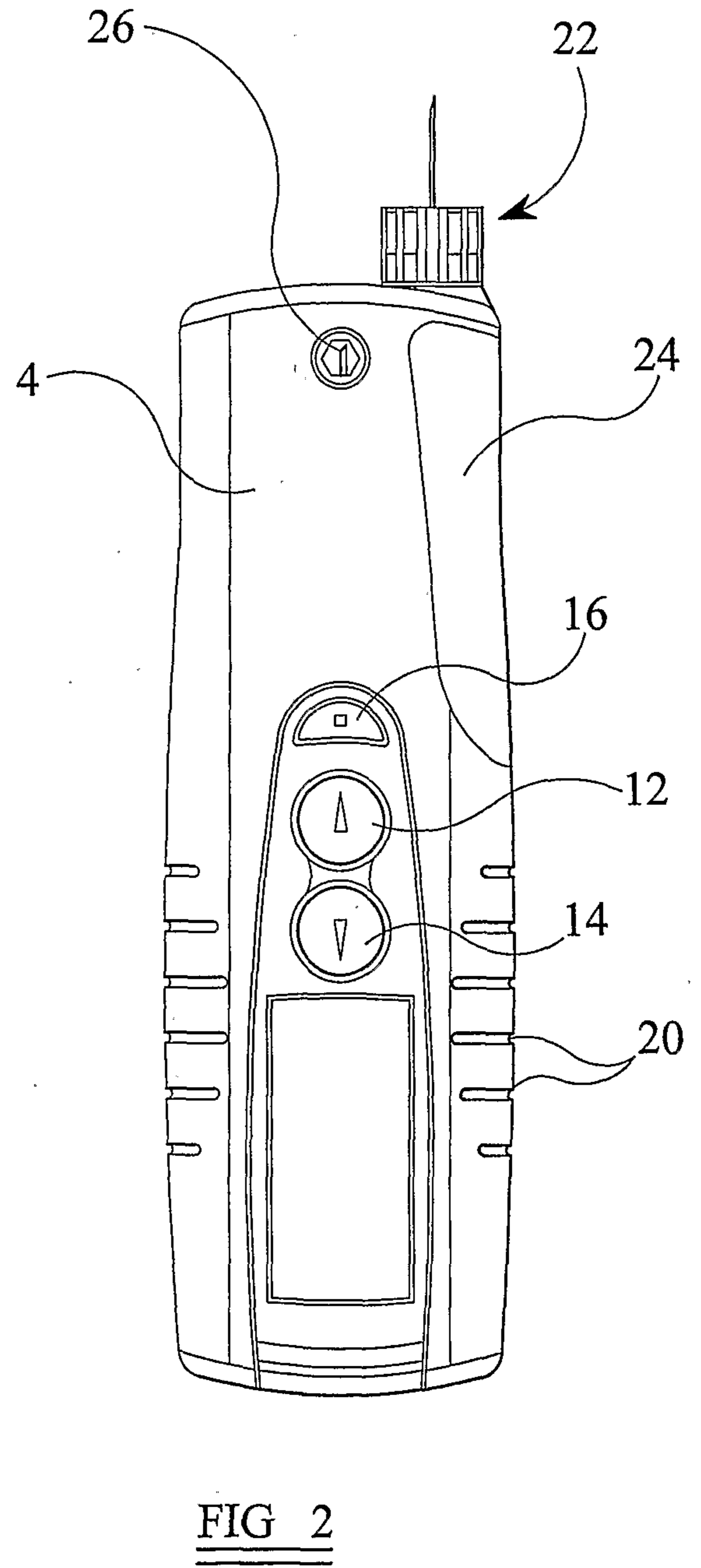
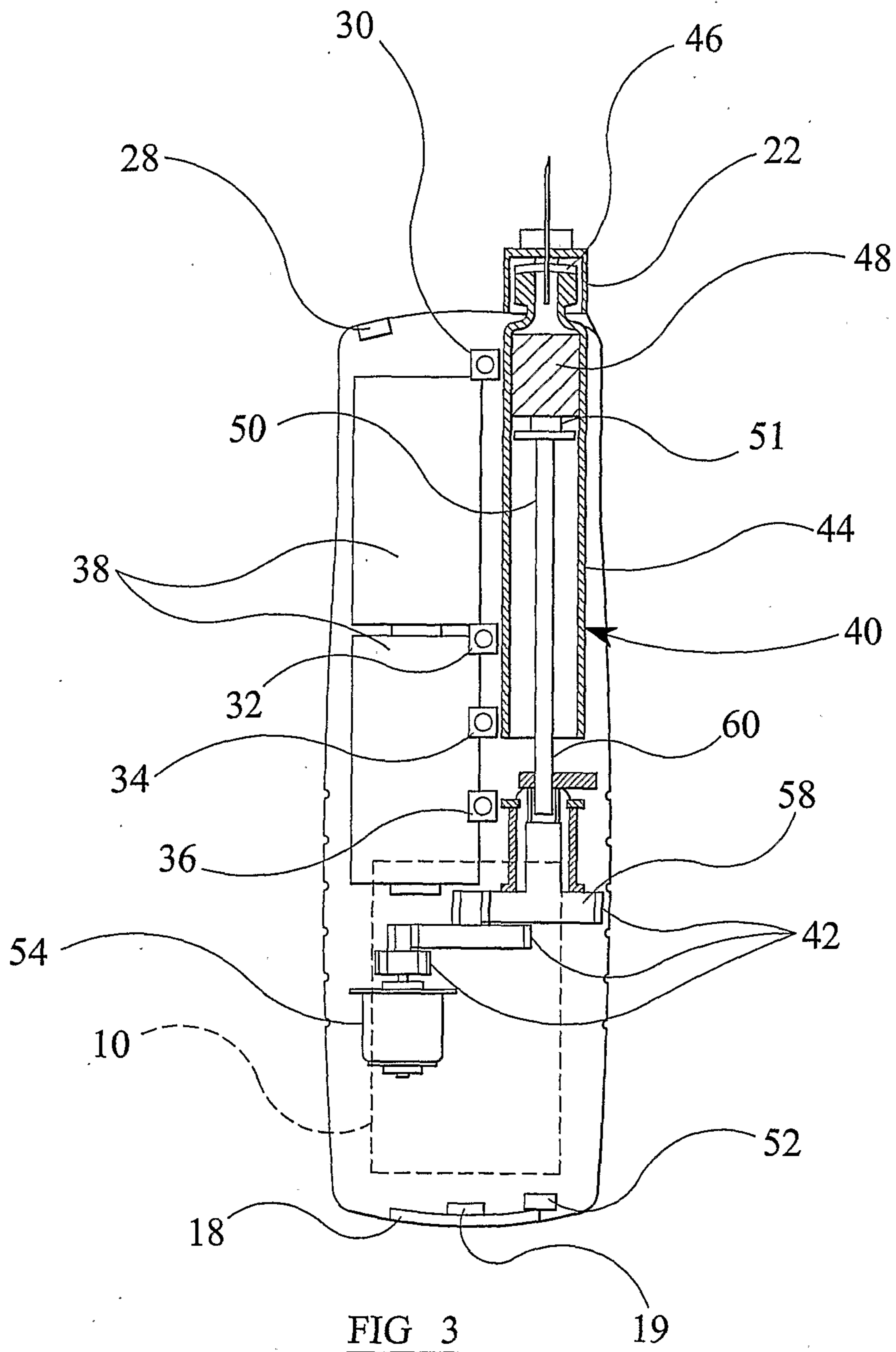

FIG 2



3 / 3

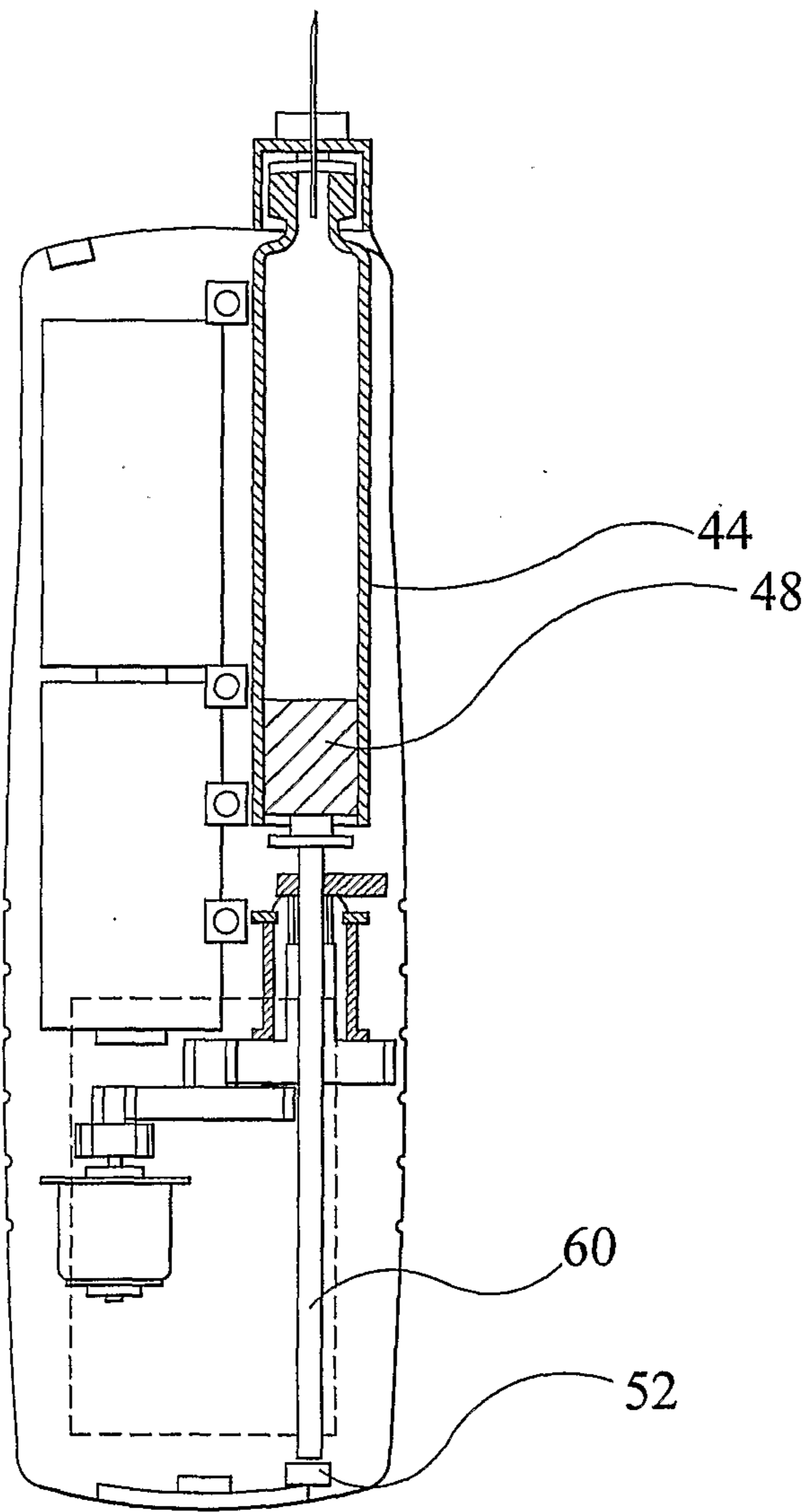

FIG 3A

