



US 20200219822A1

(19) **United States**

(12) **Patent Application Publication**

KIM et al.

(10) **Pub. No.: US 2020/0219822 A1**

(43) **Pub. Date: Jul. 9, 2020**

(54) **CONFORMAL SHIELDING FOR SOLDER BALL ARRAY**

H05K 1/02 (2006.01)
H01L 25/065 (2006.01)

(71) Applicant: **QUALCOMM Incorporated**, San Diego, CA (US)

(52) **U.S. Cl.**
CPC *H01L 23/552* (2013.01); *H01L 24/17* (2013.01); *H01L 2924/15311* (2013.01); *H05K 1/023* (2013.01); *H01L 25/0657* (2013.01); *H01L 24/49* (2013.01)

(72) Inventors: **Daniel Daeik KIM**, Del Mar, CA (US); **Manuel ALDRETE**, Encinitas, CA (US); **Babak NEJATI**, San Diego, CA (US)

(57) **ABSTRACT**

(21) Appl. No.: **16/241,958**

(22) Filed: **Jan. 7, 2019**

Publication Classification

(51) **Int. Cl.**
H01L 23/552 (2006.01)
H01L 23/00 (2006.01)

An RF/EMI shield has a substrate, a plurality of solder balls on a first side of the substrate, and a plurality of wire-bonds on a periphery of the first side of the substrate to form a shield which can be soldered in a surface mount process directly around components needing shielding. Each of the plurality of wire-bonds has a width selected as a fraction of the wavelength of interest.

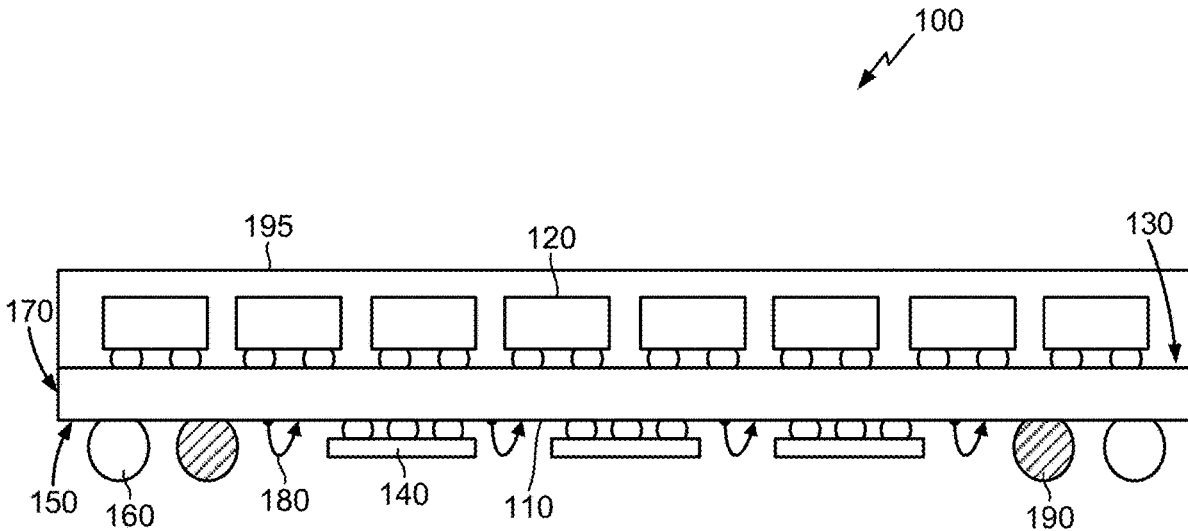

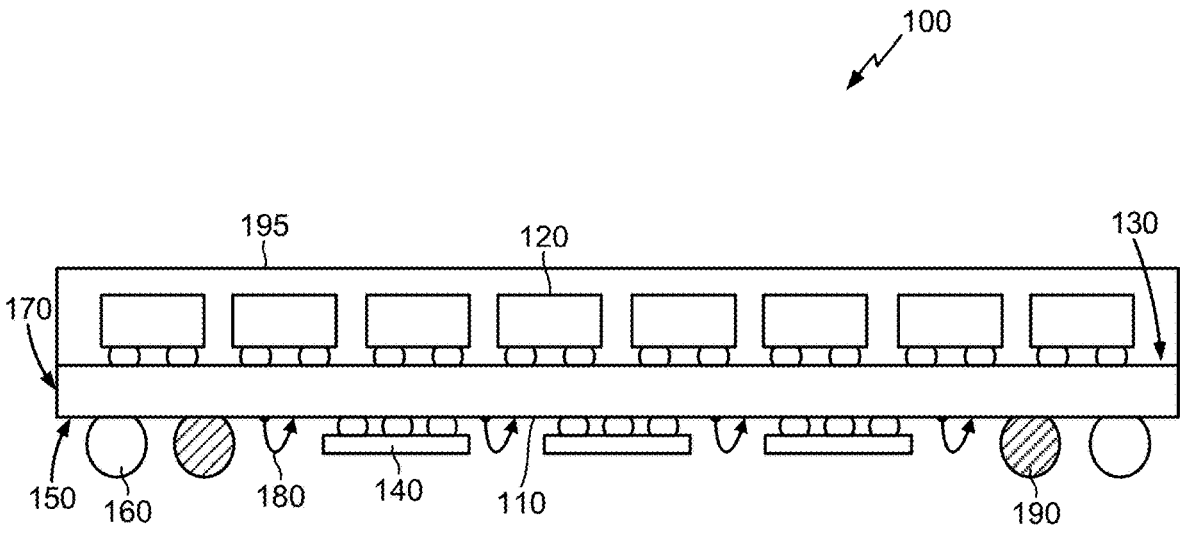

FIG. 1

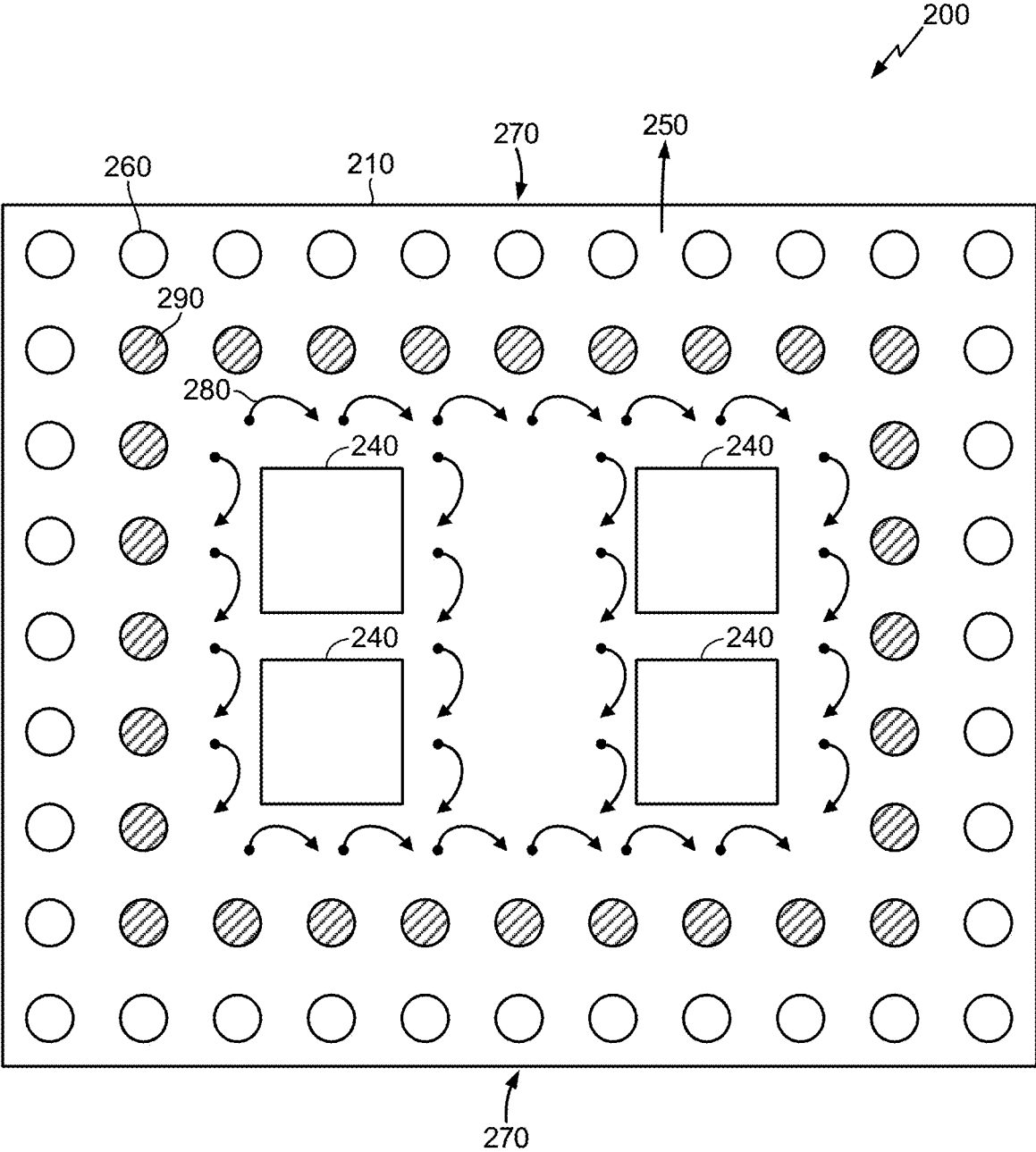

FIG. 2

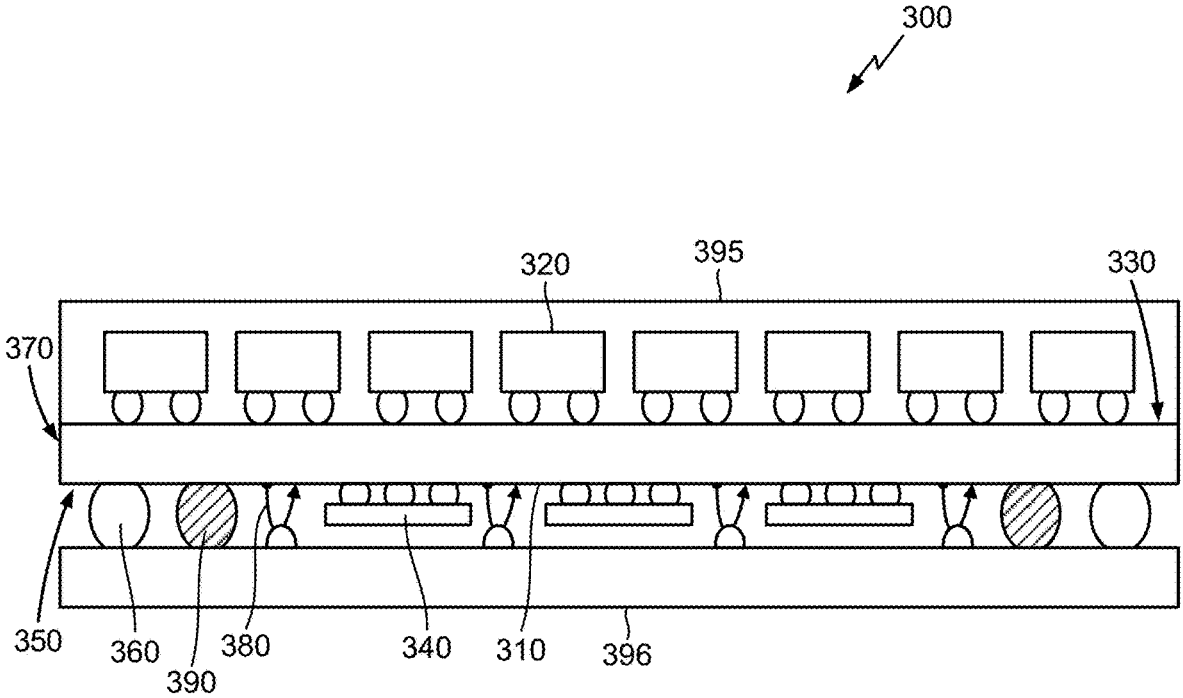

FIG. 3

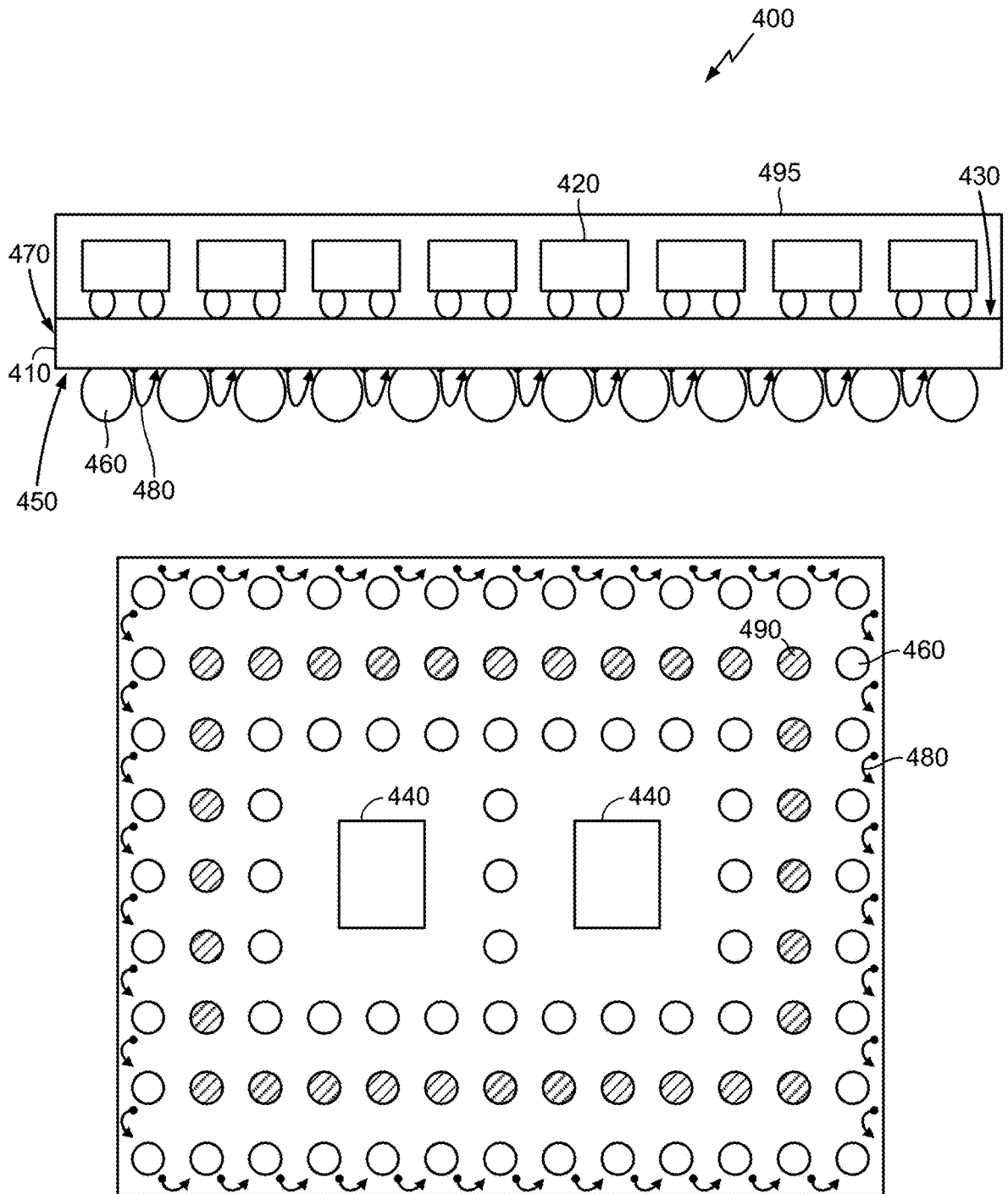

FIG. 4

500 ↘

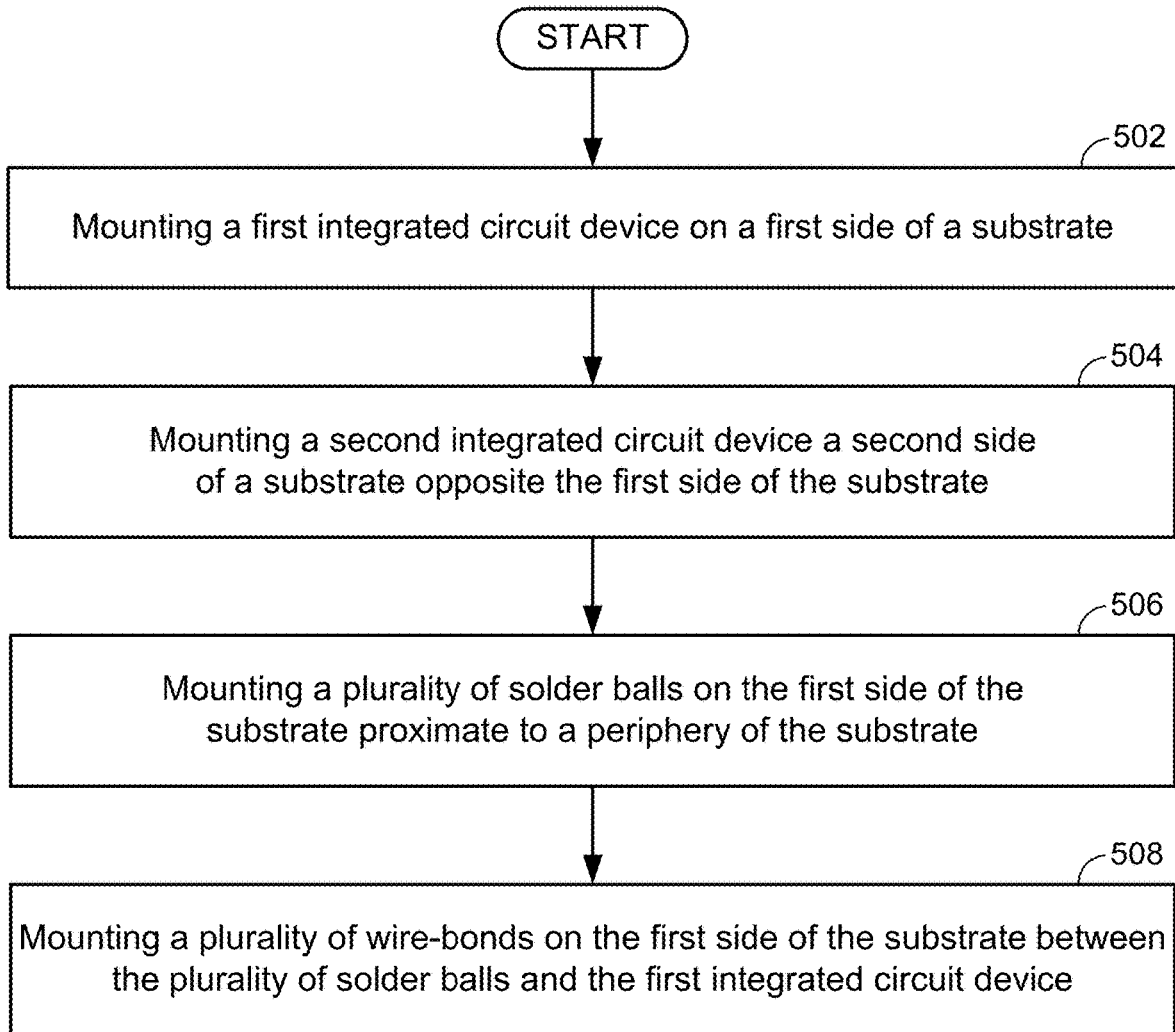

FIG. 5

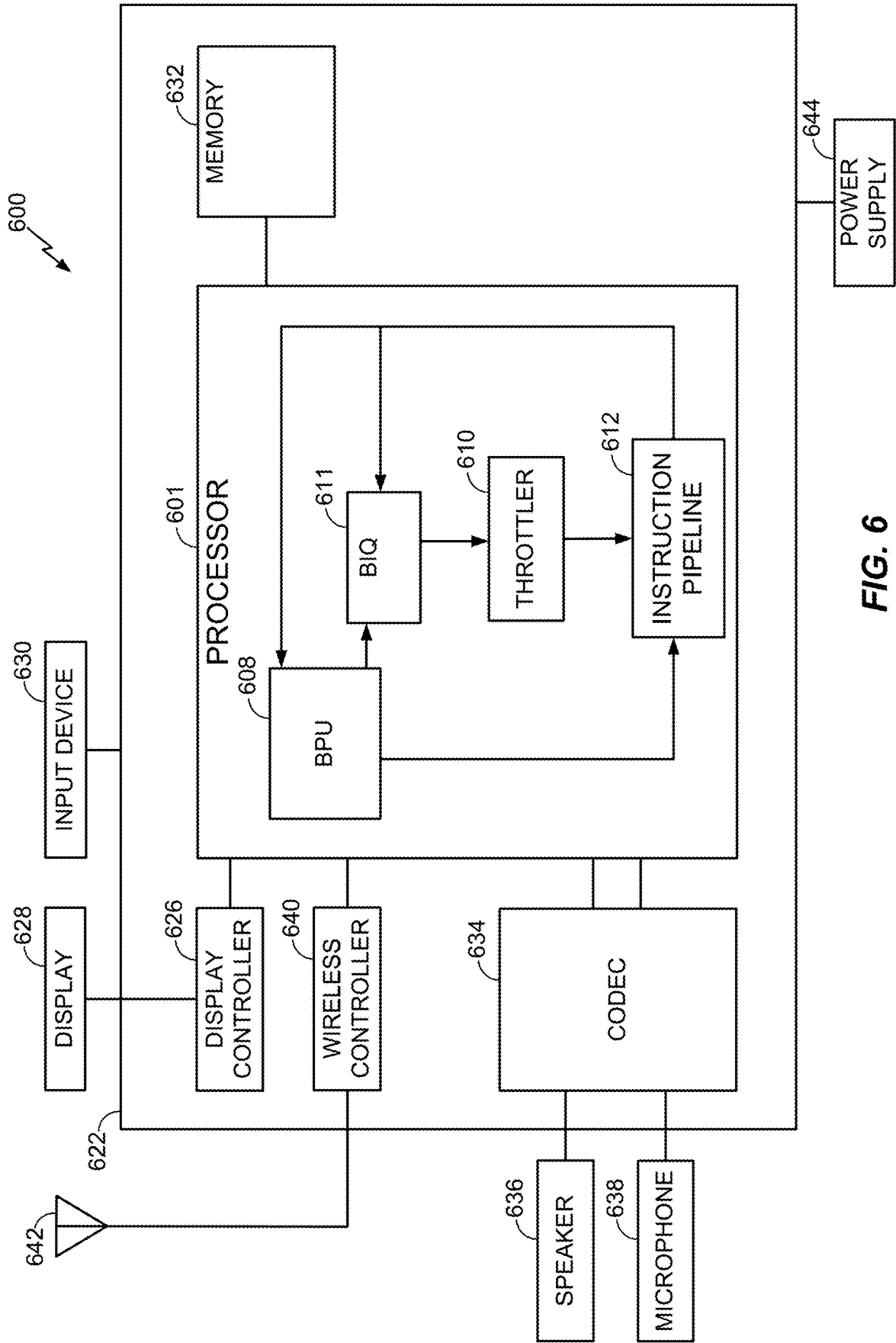

FIG. 6

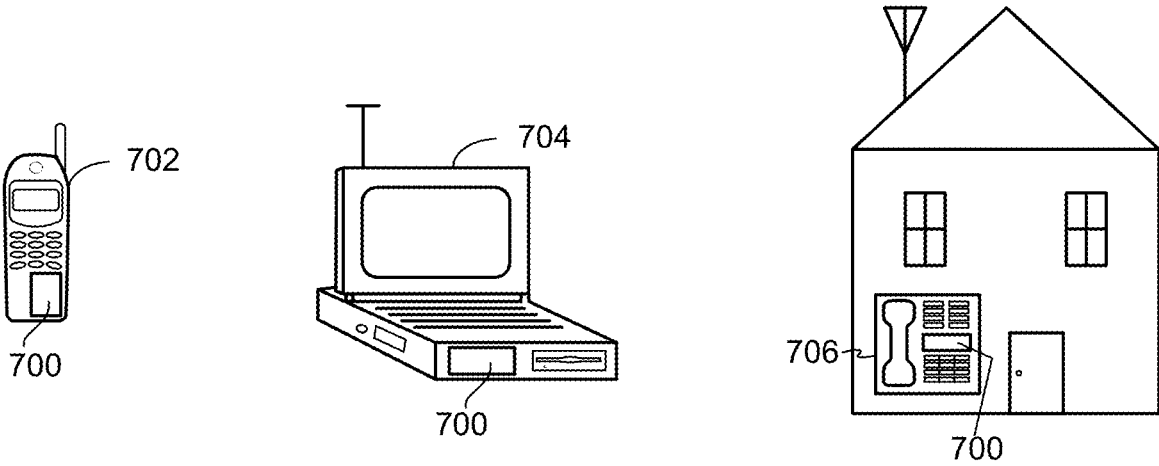

FIG. 7

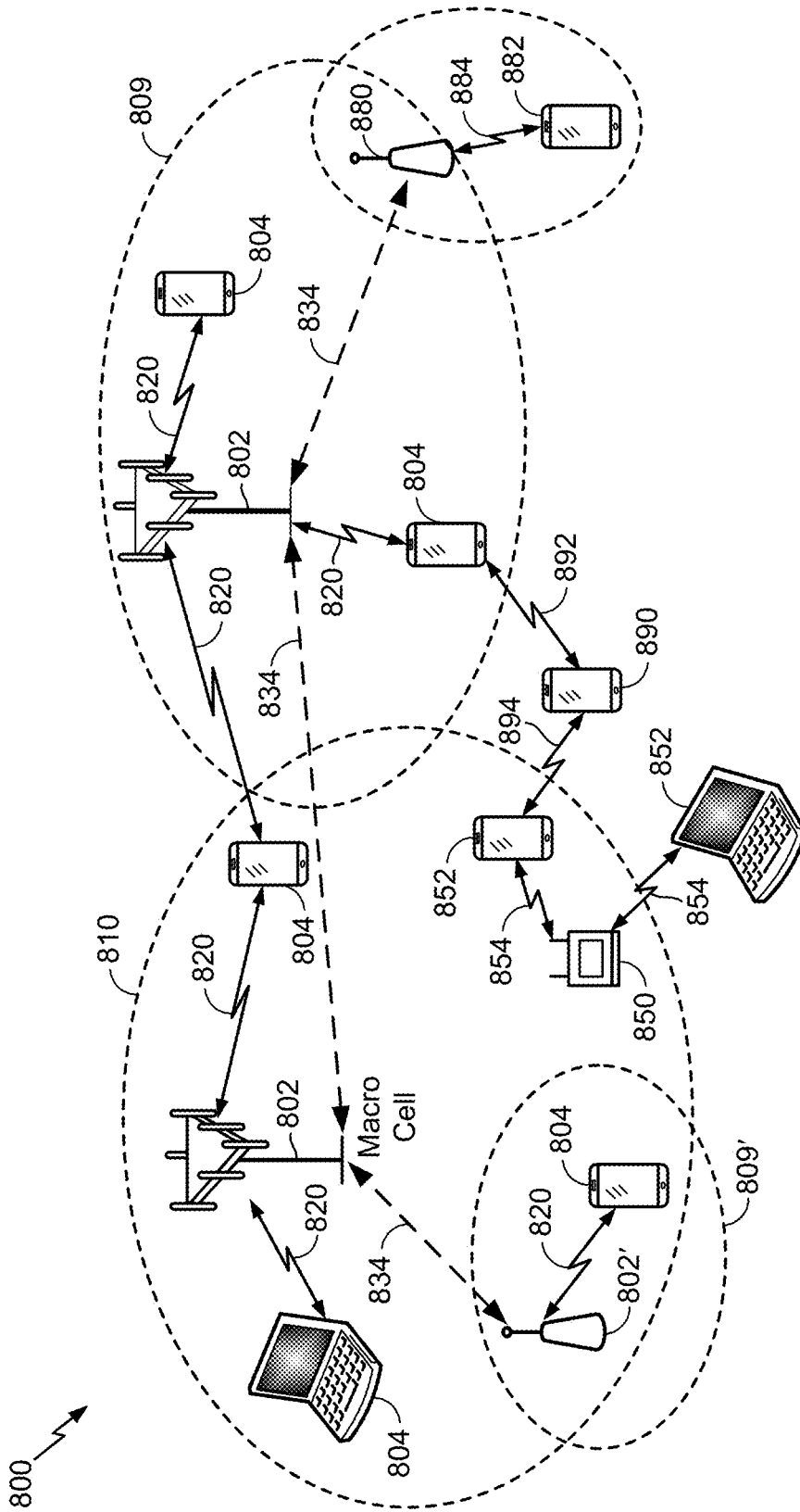

FIG. 8

CONFORMAL SHIELDING FOR SOLDER BALL ARRAY

FIELD OF DISCLOSURE

[0001] This disclosure relates generally to radio frequency (RF) shielding, and more specifically, but not exclusively, to conformal shielding for solder ball arrays.

BACKGROUND

[0002] With the continued miniaturization of electrical circuits and circuit boards, the use of conventional radio frequency (RF) and electromagnetic interference (EMI) shielding has become an increasing challenge. In the past, shields utilized solder balls of the ball grid array (BGA) to provide shielding or added a component such as pre-tinned tabs that were placed through slots in the circuit board to cover a circuit desired to be shielded. The tabs were then twisted to pull the shield tightly against the board and subsequently wave soldered to ensure electrical contact with a shielding ground connection.

[0003] As component density increases, the available real estate on a circuit board is at a premium, and designs become more constrained making the use of such conventional shielding techniques even more difficult. There exists a need, therefore, for an improved smaller shielding structure which is cost effective, as compared to the pre-existing shielding techniques, and more efficient.

[0004] Accordingly, there is a need for systems, apparatus, and methods that overcome the deficiencies of conventional approaches including the methods, system and apparatus provided hereby.

SUMMARY

[0005] The following presents a simplified summary relating to one or more aspects and/or examples associated with the apparatus and methods disclosed herein. As such, the following summary should not be considered an extensive overview relating to all contemplated aspects and/or examples, nor should the following summary be regarded to identify key or critical elements relating to all contemplated aspects and/or examples or to delineate the scope associated with any particular aspect and/or example. Accordingly, the following summary has the sole purpose to present certain concepts relating to one or more aspects and/or examples relating to the apparatus and methods disclosed herein in a simplified form to precede the detailed description presented below.

[0006] In one aspect, a RF shielding arrangement includes: a substrate having a first side and a second side opposite the first side; a second integrated circuit device mounted on the second side of the substrate; a first integrated circuit device mounted on the first side of the substrate; a plurality of solder balls on the first side of the substrate proximate to a periphery of the substrate; and a plurality of wire-bonds on the first side of the substrate between the plurality of solder balls and the first integrated circuit device.

[0007] In another aspect, a RF shielding arrangement includes: a substrate having a first side and a second side opposite the first side; a second integrated circuit device mounted on the second side of the substrate; a first integrated circuit device mounted on the first side of the substrate; a plurality of solder balls on the first side of the substrate proximate to a periphery of the substrate; and means for

shielding on the first side of the substrate between the plurality of solder balls and the first integrated circuit device.

[0008] In still another aspect, a method for making a RF shielding arrangement includes: mounting a first integrated circuit device on a first side of a substrate; mounting a second integrated circuit device on a second side of a substrate opposite the first side of the substrate; mounting a plurality of solder balls on the first side of the substrate proximate to a periphery of the substrate; and mounting a plurality of wire-bonds on the first side of the substrate between the plurality of solder balls and the first integrated circuit device.

[0009] In still another aspect, a RF shielding arrangement includes: a substrate having a first side and a second side opposite the first side; a second integrated circuit device mounted on the second side of the substrate; a first integrated circuit device mounted on the first side of the substrate; a plurality of solder balls on the first side of the substrate proximate to a periphery of the substrate; and a plurality of wire-bonds on the first side of the substrate between the plurality of solder balls, one of the plurality of wire-bonds between each of proximate ones of the plurality of solder balls.

[0010] Other features and advantages associated with the apparatus and methods disclosed herein will be apparent to those skilled in the art based on the accompanying drawings and detailed description.

BRIEF DESCRIPTION OF THE DRAWINGS

[0011] A more complete appreciation of aspects of the disclosure and many of the attendant advantages thereof will be readily obtained as the same becomes better understood by reference to the following detailed description when considered in connection with the accompanying drawings which are presented solely for illustration and not limitation of the disclosure, and in which:

[0012] FIG. 1 illustrates a side view of an exemplary RF shielding arrangement in accordance with some examples of the disclosure;

[0013] FIG. 2 illustrates a bottom view of an exemplary RF shielding arrangement in accordance with some examples of the disclosure;

[0014] FIG. 3 illustrates a side view of an exemplary RF shielding arrangement with a PCB in accordance with some examples of the disclosure;

[0015] FIG. 4 illustrates a side view and a bottom view of an exemplary RF shielding arrangement with wire-bonds at the periphery in accordance with some examples of the disclosure;

[0016] FIG. 5 illustrates an exemplary partial method for shielding integrated circuit devices in accordance with some examples of the disclosure;

[0017] FIG. 6 illustrates an exemplary mobile device in accordance with some examples of the disclosure;

[0018] FIG. 7 illustrates various electronic devices that may be integrated with any of the aforementioned integrated devices, semiconductor device, integrated circuit, die, interposer, package or package-on-package (PoP) in accordance with some examples of the disclosure; and

[0019] FIG. 8 illustrates an exemplary wireless communications system in accordance with some examples of the disclosure.

[0020] In accordance with common practice, the features depicted by the drawings may not be drawn to scale.

Accordingly, the dimensions of the depicted features may be arbitrarily expanded or reduced for clarity. In accordance with common practice, some of the drawings are simplified for clarity. Thus, the drawings may not depict all components of a particular apparatus or method. Further, like reference numerals denote like features throughout the specification and figures.

DETAILED DESCRIPTION

[0021] The exemplary methods, apparatus, and systems disclosed herein mitigate shortcomings of the conventional methods, apparatus, and systems, as well as other previously unidentified needs. For example, a wire-bond (e.g. curtain of wire bond material) may implement RF signal and domain barrier more effectively in RF isolation than ball grid array (BGA) ball barrier alone. The wire-bond is also more area efficient than BGA ball barrier. The wire-bond may make contact with printed circuit board (PCB) to strengthen RF isolation and may extend conformal shielding of a double-sided BGA (DSBGA) module to reduce RF leakage. The wire-bond may enable higher IC integration at the bottom side or reduced total module size. Exemplary apparatus and methods may use wire-bonds to isolate: signal vs. signal; signal vs. functional ICs, functional ICs vs. functional ICs; and signal domains.

[0022] FIG. 1 illustrates a side view of an exemplary RF shielding arrangement in accordance with some examples of the disclosure. As shown in FIG. 1, a RF shielding arrangement 100 may include a substrate 110 with a first side 150 and a second side 130 opposite the first side 150, a second integrated circuit device 120 mounted on the second side 130 of the substrate 110, a first integrated circuit device 140 mounted on the first side 150 of the substrate 110, a plurality of solder balls 160 on the first side 150 of the substrate 110 proximate to a periphery 170 of the substrate 110, and a plurality of wire-bonds 180 on the first side 150 of the substrate 110 between the plurality of solder balls 160 and the first integrated circuit device 140. While three first integrated circuit devices 140 are shown, it should be understood that more than three or less than three first integrated circuit devices 140 may be mounted on the first side 150 of the substrate 110. While eight second integrated circuit devices 120 are shown, it should be understood that more than eight or less than eight second integrated circuit devices 120 may be mounted on the second side 130 of the substrate 110. The RF shielding arrangement 100 may include a plurality of signal connections 190 (configured to carry signals for the RF shielding arrangement from and to external points or devices) between the plurality of solder balls 160 and the plurality of wire-bonds 180 with the plurality of solder balls 160 configured as ground connections. The RF shielding arrangement 100 may also include an encapsulant 195 enclosing the second integrated circuit device 120 on the second side 130 of the substrate 110.

[0023] In addition, the plurality of wire-bonds 180 may be located between proximate ones of the plurality of solder balls 160 in a plane parallel to the first side 150 of the substrate 110. In addition, the RF shielding arrangement 100 may be attached or mounted on a printed circuit board (e.g., not shown but see FIG. 3) proximate to the first side 150 of the substrate 110 and each of the plurality of wire-bonds 180 may be attached to the printed circuit board.

[0024] As can be seen in FIG. 1, the wire-bonds 180 are located between the signal connections 190 and the first

integrated circuit device 140 as well as between each of the first integrated circuit devices 140. This may allow closer placement of the signal connections and integrated circuit devices since the RF isolation is improved, which will result in more efficient use of the substrate area and smaller substrates/footprints than devices with conventional isolation and footprints. In addition, the wire-bonds 180 implement RF signal and domain barrier isolation, the wire-bonds 180 are more effective in RF isolation than a conventional BGA ball barrier, more area efficient than BGA ball barrier, may make contact with the PCB to strength RF isolation, may extend conformal shielding of a double-sided ball grid array (DSBGA) module to reduce RF leakage, and enable higher integrated circuit integration at the first side 150 or reduced total module size.

[0025] FIG. 2 illustrates a bottom view of an exemplary RF shielding arrangement in accordance with some examples of the disclosure. As shown in FIG. 2, a RF shielding arrangement 200 (e.g., RF shielding arrangement 100) may include a substrate 210 with a first side 250, a plurality of first integrated circuit devices 240 mounted on the first side 250 of the substrate 210, a plurality of solder balls 260 on the first side 250 of the substrate 210 proximate to a periphery 270 of the substrate 210, and a plurality of wire-bonds 280 on the first side 250 of the substrate 210 between the plurality of solder balls 260 and the first integrated circuit devices 240 as well as between the first integrated circuit devices 240. While four first integrated circuit devices 240 are shown, it should be understood that more than four or less than four first integrated circuit devices 240 may be mounted on the first side 250 of the substrate 210. The RF shielding arrangement 200 may include a plurality of signal connections 290 (configured to carry signals for the RF shielding arrangement from and to external points or devices) between the plurality of solder balls 260 and the plurality of wire-bonds 280 with the plurality of solder balls 260 configured as ground connections. In addition, the plurality of wire-bonds 280 may be located between proximate ones of the plurality of solder balls 260 in a plane parallel to the first side 250 of the substrate 210.

[0026] FIG. 3 illustrates a side view of an exemplary RF shielding arrangement with a PCB in accordance with some examples of the disclosure. As shown in FIG. 3, a RF shielding arrangement 300 (e.g., RF shielding arrangements 100 and 200) may include a substrate 310 with a first side 350 and a second side 330 opposite the first side 350, a second integrated circuit device 320 mounted on the second side 330 of the substrate 310, a first integrated circuit device 340 mounted on the first side 350 of the substrate 310, a plurality of solder balls 360 on the first side 350 of the substrate 310 proximate to a periphery 370 of the substrate 310, and a plurality of wire-bonds 380 on the first side 350 of the substrate 310 between the plurality of solder balls 360 and the first integrated circuit device 340. While three first integrated circuit devices 340 are shown, it should be understood that more than three or less than three first integrated circuit devices 340 may be mounted on the first side 350 of the substrate 310. While eight second integrated circuit devices 320 are shown, it should be understood that more than eight or less than eight second integrated circuit devices 320 may be mounted on the second side 330 of the substrate 310. The RF shielding arrangement 300 may include a plurality of signal connections 390 (configured to

carry signals for the RF shielding arrangement from and to external points or devices) between the plurality of solder balls **360** and the plurality of wire-bonds **380** with the plurality of solder balls **360** configured as ground connections. The RF shielding arrangement **300** may also include an encapsulant **395** enclosing the second integrated circuit device **320** on the second side **330** of the substrate **310**.

[0027] In addition, the plurality of wire-bonds **380** may be located between proximate ones of the plurality of solder balls **360** in a plane parallel to the first side **350** of the substrate **310**. In addition, the RF shielding arrangement **300** may be attached or mounted on a printed circuit board **396** proximate to the first side **350** of the substrate **310** and each of the plurality of wire-bonds **380** may be attached to the printed circuit board **396** using, for example, solder or paste.

[0028] As can be seen in FIG. 3, the wire-bonds **380** are located between the signal connections **390** and the first integrated circuit device **340** as well as between each of the first integrated circuit devices **340**. This may allow closer placement of the signal connections and integrated circuit devices since the RF isolation is improved, which will result in more efficient use of the substrate area and smaller substrates/footprints than devices with conventional isolation and footprints. In addition, the wire-bonds **380** implement RF signal and domain barrier isolation, the wire-bonds **380** are more effective in RF isolation than a conventional BGA ball barrier, more area efficient than a conventional BGA ball barrier, may make contact with the PCB to strength RF isolation, may extend conformal shielding of a double-sided ball grid array (DSBGA) module to reduce RF leakage, and enable higher integrated circuit integration at the first side **350** or reduced total module size. It should be understood that the plurality of solder balls **360** and the plurality of signal connections **390** may be attached or mounted on the printed circuit board **396** for ground or signal connections, respectively.

[0029] FIG. 4 illustrates a side view and a bottom view of an exemplary RF shielding arrangement with wire-bonds at the periphery in accordance with some examples of the disclosure. As shown in FIG. 4, a RF shielding arrangement **400** (e.g., RF shielding arrangements **100**, **200**, and **300**) may include a substrate **410** with a first side **450** and a second side **430** opposite the first side **450**, a second integrated circuit device **420** mounted on the second side **430** of the substrate **410**, a first integrated circuit device **440** mounted on the first side **450** of the substrate **410**, a plurality of solder balls **460** on the first side **450** of the substrate **410** proximate to a periphery **470** of the substrate **410**, and a plurality of wire-bond wires **480** on the first side **450** of the substrate **410** between the plurality of solder balls **460**. While only one such wire-bond wire **480** is shown, it should be understood that another wire-bond wire **480** may be used in place of the solder balls **460** that surround the first integrated circuit device **440** to provide additional isolation. While two first integrated circuit devices **440** are shown, it should be understood that more than two or less than two first integrated circuit devices **440** may be mounted on the first side **450** of the substrate **410**. While eight second integrated circuit devices **420** are shown, it should be understood that more than eight or less than eight second integrated circuit devices **420** may be mounted on the second side **430** of the substrate **410**. The RF shielding arrangement **400** may include a plurality of signal connections **490** (configured to carry signals for the RF shielding

arrangement from and to external points or devices) between the plurality of solder balls **460** and the first integrated circuit devices **440** with the plurality of solder balls **460** configured as ground connections. The RF shielding arrangement **400** may also include an encapsulant **495** enclosing the second integrated circuit device **420** on the second side **430** of the substrate **410**.

[0030] In addition, the plurality of wire-bonds **480** may be located between proximate ones of the plurality of solder balls **460**. In addition, the RF shielding arrangement **400** may be attached or mounted on a printed circuit board (e.g., not shown but see FIG. 3) proximate to the first side **450** of the substrate **410** and each of the plurality of wire-bonds **480** may be attached to the printed circuit board.

[0031] As can be seen in FIG. 4, the wire-bonds **480** are located between adjacent or proximate solder balls **460**. This may allow closer placement of the signal connections and integrated circuit devices since the RF isolation is improved by a constant ground wire-bond wire on the periphery **470**, which will result in more efficient use of the substrate area and smaller substrates/footprints than devices with conventional isolation and footprints. In addition, the wire-bonds **480** implement RF signal and domain barrier isolation, the wire-bonds **480** are more effective in RF isolation than a conventional BGA ball barrier, more area efficient than a conventional BGA ball barrier, may make contact with the PCB to strength RF isolation, may extend conformal shielding of a double-sided ball grid array (DSBGA) module to reduce RF leakage, and enable higher integrated circuit integration at the first side **450** or reduced total module size. Alternatively, the wire-bonds **480** may replace the outermost solder balls **460** or be outside the solder balls **460** on the periphery **470** to provide complete shielding for the RF shielding arrangement **400**.

[0032] FIG. 5 illustrates an exemplary partial method **500** for shielding integrated circuit devices in accordance with some examples of the disclosure. The partial method **500** begins in block **502** with mounting a first integrated circuit device on a first side of a substrate. The partial method **500** continues in block **504** with mounting a second integrated circuit device on a second side of a substrate opposite the first side of the substrate. The partial method **500** continues in block **506** with mounting a plurality of solder balls on the first side of the substrate proximate to a periphery of the substrate. The partial method **500** may conclude in block **508** with mounting a plurality of wire-bonds on the first side of the substrate between the plurality of solder balls and the first integrated circuit device. Alternatively, the partial method **500** may include mounting a first plurality of signal connections between the plurality of solder balls and the plurality of wire-bonds and wherein the plurality of solder balls are configured as ground connections; mounting the first side of the substrate to a printed circuit board and mounting each of the plurality of wire-bonds to the printed circuit board; and enclosing the second integrated circuit device on the second side of the substrate with an encapsulant.

[0033] It will be appreciated that various aspects disclosed herein can be described as functional equivalents to the structures, materials and/or devices described and/or recognized by those skilled in the art. For example, in one aspect, a RF shielding arrangement may comprise a substrate (e.g., substrates **110**, **210**, **310**, and **410**) having a first side and a second side opposite the first side; a second integrated

circuit device (e.g., second integrated circuit devices **120**, **320**, and **420**) mounted on the second side of the substrate; a first integrated circuit device (e.g., first integrated circuit devices **140**, **240**, **340**, and **440**) mounted on the first side of the substrate; a plurality of solder balls (e.g., solder balls **160**, **260**, **360**, and **460**) on the first side of the substrate proximate to a periphery of the substrate; and means for shielding (e.g., wire-bonds **180**, **280**, **380**, and **480**) on the first side of the substrate between the plurality of solder balls and the first integrated circuit device. It will be appreciated that the aforementioned aspects are merely provided as examples and the various aspects claimed are not limited to the specific references and/or illustrations cited as examples.

[0034] The wire-bond (e.g., wire-bond **180**, **280**, **380**, and **480**) may provide better isolation than the balls in the BGA since the pitch for the balls in the BGA are typically **400** micro-meters while the wire-bonds of the wire-bond may have a smaller pitch, such as **90** micro-meters. In addition, the wire-bonds may be a loop with both ends attached or mounted to the substrate (using pads, solder, or other suitable mechanisms) and the width of the loop configured to be less than the wavelength of the frequency of interest (the frequency that is being blocked). The wire-bonds may have other shapes than a loop and may comprise suitable conductive material to provide the desired RF isolation. The height of the wire-bonds may be configured such that it is approximately equal to the height of the solder balls. The wire-bond may be grounded or not through the substrate (or PCB is attached to the PCB). In addition, the wire-bond may be configured to provide a u-shaped cage around the first integrated circuit devices enclosing the sides and the bottom except for the top side attached to the substrate. In addition, two separate wire-bonds may be used each having a different pitch or width and height dimensions. For example, one wire-bond may be configured for one frequency range and the other wire-bond may be configured for another frequency range.

[0035] FIG. 6 illustrates an exemplary mobile device in accordance with some examples of the disclosure. Referring now to FIG. 6, a block diagram of a mobile device that is configured according to exemplary aspects is depicted and generally designated **600**. In some aspects, mobile device **600** may be configured as a wireless communication device. As shown, mobile device **600** includes processor **601**, which may be configured to implement the methods described herein in some aspects. Processor **601** is shown to comprise instruction pipeline **612**, buffer processing unit (BPU) **608**, branch instruction queue (BIQ) **611**, and throttler **610** as is well known in the art. Other well-known details (e.g., counters, entries, confidence fields, weighted sum, comparator, etc.) of these blocks have been omitted from this view of processor **601** for the sake of clarity.

[0036] Processor **601** may be communicatively coupled to memory **632** over a link, which may be a die-to-die or chip-to-chip link. Mobile device **600** also include display **628** and display controller **626**, with display controller **626** coupled to processor **601** and to display **628**.

[0037] In some aspects, FIG. 6 may include coder/decoder (CODEC) **634** (e.g., an audio and/or voice CODEC) coupled to processor **601**; speaker **636** and microphone **638** coupled to CODEC **634**; and wireless controller **640** (which may include a modem) coupled to wireless antenna **642** and to processor **601**.

[0038] In a particular aspect, where one or more of the above-mentioned blocks are present, processor **601**, display controller **626**, memory **632**, CODEC **634**, and wireless controller **640** can be included in a system-in-package or system-on-chip device **622**. Input device **630** (e.g., physical or virtual keyboard), power supply **644** (e.g., battery), display **628**, speaker **636**, microphone **638**, and wireless antenna **642**, may be external to system-on-chip device **622** and may be coupled to a component of system-on-chip device **622**, such as an interface or a controller.

[0039] It should be noted that although FIG. 6 depicts a mobile device **600**, processor **601** and memory **632** may also be integrated into a set top box, a music player, a video player, an entertainment unit, a navigation device, a personal digital assistant (PDA), a fixed location data unit, a computer, a laptop, a tablet, a communications device, a mobile phone, or other similar devices.

[0040] FIG. 7 illustrates various electronic devices that may be integrated with any of the aforementioned RF shielding arrangements in accordance with some examples of the disclosure. For example, a mobile phone device **702**, a laptop computer device **704**, and a fixed location terminal device **706** may include an integrated device **700** as described herein. The integrated device **700** may be, for example, any of the integrated circuits, dies, integrated devices, integrated device packages, integrated circuit devices, device packages, integrated circuit (IC) packages, package-on-package devices described herein. The devices **702**, **704**, **706** illustrated in FIG. 7 are merely exemplary. Other electronic devices may also feature the integrated device **700** including, but not limited to, a group of devices (e.g., electronic devices) that includes mobile devices, handheld personal communication systems (PCS) units, portable data units such as personal digital assistants, global positioning system (GPS) enabled devices, navigation devices, set top boxes, music players, video players, entertainment units, fixed location data units such as meter reading equipment, communications devices, smartphones, tablet computers, computers, wearable devices, servers, routers, electronic devices implemented in automotive vehicles (e.g., autonomous vehicles), or any other device that stores or retrieves data or computer instructions, or any combination thereof.

[0041] According to various aspects, FIG. 8 illustrates an exemplary wireless communications system **800** that may be used with the concepts described herein. The wireless communications system **800** (which may also be referred to as a wireless wide area network (WWAN)) may include various base stations **802** and various UEs **804**. The base stations **802** may include macro cells (high power cellular base stations) and/or small cells (low power cellular base stations), wherein the macro cells may include Evolved NodeBs (eNBs), where the wireless communications system **800** corresponds to an LTE network, or gNodeBs (gNBs), where the wireless communications system **800** corresponds to a 5G network or a combination of both, and the small cells may include femtocells, picocells, microcells, etc.

[0042] The base stations **802** may collectively form a Radio Access Network (RAN) and interface with an Evolved Packet Core (EPC) or Next Generation Core (NGC) through backhaul links. In addition to other functions, the base stations **802** may perform functions that relate to one or more of transferring user data, radio channel ciphering and deciphering, integrity protection, header compression, mobility control functions (e.g., handover, dual connectiv-

ity), inter-cell interference coordination, connection setup and release, load balancing, distribution for non-access stratum (NAS) messages, NAS node selection, synchronization, RAN sharing, multimedia broadcast multicast service (MBMS), subscriber and equipment trace, RAN information management (RIM), paging, positioning, and delivery of warning messages. The base stations **802** may communicate with each other directly or indirectly (e.g., through the EPC/NGC) over backhaul links **834**, which may be wired or wireless.

[0043] The base stations **802** may wirelessly communicate with the UEs **804**. Each of the base stations **802** may provide communication coverage for a respective geographic coverage area **809**. In an aspect, although not shown in FIG. **8**, coverage areas **809** may be subdivided into a plurality of cells (e.g., three), or sectors, each cell corresponding to a single antenna or array of antennas of a base station **802**. As used herein, the term “cell” or “sector” may correspond to one of a plurality of cells of a base station **802**, or to the base station **802** itself, depending on the context.

[0044] While neighboring macro cell geographic coverage areas **809** may partially overlap (e.g., in a handover region), some of the geographic coverage areas **809** may be substantially overlapped by a larger geographic coverage area **810**. For example, a small cell base station **802'** may have a coverage area **809'** that substantially overlaps with the coverage area **809** of one or more macro cell base stations **802**. A network that includes both small cell and macro cells may be known as a heterogeneous network. A heterogeneous network may also include Home eNBs (HeNBs), which may provide service to a restricted group known as a closed subscriber group (CSG). The communication links **820** between the base stations **802** and the UEs **804** may include uplink (UL) (also referred to as reverse link) transmissions from a UE **804** to a base station **802** and/or downlink (DL) (also referred to as forward link) transmissions from a base station **802** to a UE **804**. The communication links **820** may use MIMO antenna technology, including spatial multiplexing, beamforming, and/or transmit diversity. The communication links may be through one or more carriers. Allocation of carriers may be asymmetric with respect to DL and UL (e.g., more or less carriers may be allocated for DL than for UL).

[0045] The wireless communications system **800** may further include a wireless local area network (WLAN) access point (AP) **850** in communication with WLAN stations (STAs) **852** via communication links **854** in an unlicensed frequency spectrum (e.g., 5 GHz). When communicating in an unlicensed frequency spectrum, the WLAN STAs **852** and/or the WLAN AP **850** may perform a clear channel assessment (CCA) prior to communicating in order to determine whether the channel is available.

[0046] The small cell base station **802'** may operate in a licensed and/or an unlicensed frequency spectrum. When operating in an unlicensed frequency spectrum, the small cell base station **802'** may employ LTE or SG technology and use the same 5 GHz unlicensed frequency spectrum as used by the WLAN AP **850**. The small cell base station **802'**, employing LTE/5G in an unlicensed frequency spectrum, may boost coverage to and/or increase capacity of the access network. LTE in an unlicensed spectrum may be referred to as LTE-unlicensed (LTE-U), licensed assisted access (LAA), or MulteFire.

[0047] The wireless communications system **800** may further include a mmW base station **880** that may operate in mmW frequencies and/or near mmW frequencies in communication with a UE **882**. Extremely high frequency (EHF) is part of the RF in the electromagnetic spectrum. EHF has a range of 30 GHz to 300 GHz and a wavelength between 1 millimeter and 10 millimeters. Radio waves in this band may be referred to as a millimeter wave. Near mmW may extend down to a frequency of 3 GHz with a wavelength of 100 millimeters. The super high frequency (SHF) band extends between 3 GHz and 30 GHz, also referred to as centimeter wave. Communications using the mmW/near mmW radio frequency band have high path loss and a relatively short range. The mmW base station **880** may utilize beamforming **884** with the UE **882** to compensate for the extremely high path loss and short range. Further, it will be appreciated that in alternative configurations, one or more base stations **802** may also transmit using mmW or near mmW and beamforming. Accordingly, it will be appreciated that the foregoing illustrations are merely examples and should not be construed to limit the various aspects disclosed herein.

[0048] The wireless communications system **800** may further include one or more UEs, such as UE **890**, that connects indirectly to one or more communication networks via one or more device-to-device (D2D) peer-to-peer (P2P) links. In the embodiment of FIG. **8**, UE **890** has a D2D P2P link **892** with one of the UEs **804** connected to one of the base stations **802** (e.g., through which UE **890** may indirectly obtain cellular connectivity) and a D2D P2P link **894** with WLAN STA **852** connected to the WLAN AP **850** (through which UE **890** may indirectly obtain WLAN-based Internet connectivity). In an example, the D2D P2P links **892-894** may be supported with any well-known D2D radio access technology (RAT), such as LTE Direct (LTE-D), WiFi Direct (WiFi-D), Bluetooth, and so on.

[0049] One or more of the components, processes, features, and/or functions illustrated in FIGS. **1-8** may be rearranged and/or combined into a single component, process, feature or function or incorporated in several components, processes, or functions. Additional elements, components, processes, and/or functions may also be added without departing from the disclosure. It should also be noted that FIGS. **1-8** and its corresponding description in the present disclosure is not limited to dies and/or ICs. In some implementations, FIGS. **1-8** and its corresponding description may be used to manufacture, create, provide, and/or produce integrated devices. In some implementations, a device may include a die, an integrated device, a die package, an integrated circuit (IC), a device package, an integrated circuit (IC) package, a wafer, a semiconductor device, a package on package (PoP) device, and/or an interposer.

[0050] As used herein, the terms “user equipment” (or “UE”), “user device,” “user terminal,” “client device,” “communication device,” “wireless device,” “wireless communications device,” “handheld device,” “mobile device,” “mobile terminal,” “mobile station,” “handset,” “access terminal,” “subscriber device,” “subscriber terminal,” “subscriber station,” “terminal,” and variants thereof may interchangeably refer to any suitable mobile or stationary device that can receive wireless communication and/or navigation signals. These terms include, but are not limited to, a music player, a video player, an entertainment unit, a navigation

device, a communications device, a smartphone, a personal digital assistant, a fixed location terminal, a tablet computer, a computer, a wearable device, a laptop computer, a server, an automotive device in an automotive vehicle, and/or other types of portable electronic devices typically carried by a person and/or having communication capabilities (e.g., wireless, cellular, infrared, short-range radio, etc.). These terms are also intended to include devices which communicate with another device that can receive wireless communication and/or navigation signals such as by short-range wireless, infrared, wireline connection, or other connection, regardless of whether satellite signal reception, assistance data reception, and/or position-related processing occurs at the device or at the other device. In addition, these terms are intended to include all devices, including wireless and wireline communication devices, that are able to communicate with a core network via a radio access network (RAN), and through the core network the UEs can be connected with external networks such as the Internet and with other UEs. Of course, other mechanisms of connecting to the core network and/or the Internet are also possible for the UEs, such as over a wired access network, a wireless local area network (WLAN) (e.g., based on IEEE 802.11, etc.) and so on. UEs can be embodied by any of a number of types of devices including but not limited to printed circuit (PC) cards, compact flash devices, external or internal modems, wireless or wireline phones, smartphones, tablets, tracking devices, asset tags, and so on. A communication link through which UEs can send signals to a RAN is called an uplink channel (e.g., a reverse traffic channel, a reverse control channel, an access channel, etc.). A communication link through which the RAN can send signals to UEs is called a downlink or forward link channel (e.g., a paging channel, a control channel, a broadcast channel, a forward traffic channel, etc.). As used herein the term traffic channel (TCH) can refer to either an uplink/reverse or downlink/forward traffic channel.

[0051] The wireless communication between electronic devices can be based on different technologies, such as code division multiple access (CDMA), W-CDMA, time division multiple access (TDMA), frequency division multiple access (FDMA), Orthogonal Frequency Division Multiplexing (OFDM), Global System for Mobile Communications (GSM), 3GPP Long Term Evolution (LTE), Bluetooth (BT), Bluetooth Low Energy (BLE), IEEE 802.11 (WiFi), and IEEE 802.15.4 (Zigbee/Thread) or other protocols that may be used in a wireless communications network or a data communications network. Bluetooth Low Energy (also known as Bluetooth LE, BLE, and Bluetooth Smart) is a wireless personal area network technology designed and marketed by the Bluetooth Special Interest Group intended to provide considerably reduced power consumption and cost while maintaining a similar communication range. BLE was merged into the main Bluetooth standard in 2010 with the adoption of the Bluetooth Core Specification Version 4.0 and updated in Bluetooth 5 (both expressly incorporated herein in their entirety).

[0052] The word “exemplary” is used herein to mean “serving as an example, instance, or illustration.” Any details described herein as “exemplary” is not to be construed as advantageous over other examples. Likewise, the term “examples” does not mean that all examples include the discussed feature, advantage or mode of operation. Furthermore, a particular feature and/or structure can be

combined with one or more other features and/or structures. Moreover, at least a portion of the apparatus described hereby can be configured to perform at least a portion of a method described hereby.

[0053] The terminology used herein is for the purpose of describing particular examples and is not intended to be limiting of examples of the disclosure. As used herein, the singular forms “a,” “an,” and “the” are intended to include the plural forms as well, unless the context clearly indicates otherwise. It will be further understood that the terms “comprises,” “comprising,” “includes,” and/or “including,” when used herein, specify the presence of stated features, integers, actions, operations, elements, and/or components, but do not preclude the presence or addition of one or more other features, integers, actions, operations, elements, components, and/or groups thereof.

[0054] It should be noted that the terms “connected,” “coupled,” or any variant thereof, mean any connection or coupling, either direct or indirect, between elements, and can encompass a presence of an intermediate element between two elements that are “connected” or “coupled” together via the intermediate element.

[0055] Any reference herein to an element using a designation such as “first,” “second,” and so forth does not limit the quantity and/or order of those elements. Rather, these designations are used as a convenient method of distinguishing between two or more elements and/or instances of an element. Also, unless stated otherwise, a set of elements can comprise one or more elements.

[0056] Those skilled in the art will appreciate that information and signals may be represented using any of a variety of different technologies and techniques. For example, data, instructions, commands, information, signals, bits, symbols, and chips that may be referenced throughout the above description may be represented by voltages, currents, electromagnetic waves, magnetic fields or particles, optical fields or particles, or any combination thereof.

[0057] The various illustrative logical blocks, modules, and circuits described in connection with the aspects disclosed herein may be implemented or performed with a general purpose processor, a digital signal processor (DSP), an application specific integrated circuit (ASIC), a field programmable gate array (FPGA) or other programmable logic device, discrete gate or transistor logic, discrete hardware components, or any combination thereof designed to perform the functions described herein. A general purpose processor may be a microprocessor, but in the alternative, the processor may be any conventional processor, controller, microcontroller, or state machine. A processor may also be implemented as a combination of computing devices (e.g., a combination of a DSP and a microprocessor, a plurality of microprocessors, one or more microprocessors in conjunction with a DSP core, or other such configurations). Additionally, these sequence of actions described herein can be considered to be incorporated entirely within any form of computer-readable storage medium having stored therein a corresponding set of computer instructions that upon execution would cause an associated processor to perform the functionality described herein. Thus, the various aspects of the disclosure may be incorporated in a number of different forms, all of which have been contemplated to be within the scope of the claimed subject matter. In addition, for each of the examples described herein, the corresponding form of

any such examples may be described herein as, for example, “logic configured to” perform the described action.

[0058] Nothing stated or illustrated depicted in this application is intended to dedicate any component, action, feature, benefit, advantage, or equivalent to the public, regardless of whether the component, action, feature, benefit, advantage, or the equivalent is recited in the claims.

[0059] Further, those of skill in the art will appreciate that the various illustrative logical blocks, modules, circuits, and algorithm actions described in connection with the examples disclosed herein may be implemented as electronic hardware, computer software, or combinations of both. To clearly illustrate this interchangeability of hardware and software, various illustrative components, blocks, modules, circuits, and actions have been described above generally in terms of their functionality. Whether such functionality is implemented as hardware or software depends upon the particular application and design constraints imposed on the overall system. Skilled artisans may implement the described functionality in varying ways for each particular application, but such implementation decisions should not be interpreted as causing a departure from the scope of the present disclosure.

[0060] The methods, sequences and/or algorithms described in connection with the examples disclosed herein may be incorporated directly in hardware, in a software module executed by a processor, or in a combination of the two. A software module may reside in RAM memory, flash memory, ROM memory, EPROM memory, EEPROM memory, registers, hard disk, a removable disk, a CD-ROM, or any other form of storage medium known in the art including non-transitory types of memory or storage mediums. An exemplary storage medium is coupled to the processor such that the processor can read information from, and write information to, the storage medium. In the alternative, the storage medium may be integral to the processor.

[0061] The various illustrative logical blocks, modules, and circuits described in connection with the aspects disclosed herein may be implemented or performed with a general purpose processor, a digital signal processor (DSP), an application specific integrated circuit (ASIC), a field programmable gate array (FPGA) or other programmable logic device, discrete gate or transistor logic, discrete hardware components, or any combination thereof designed to perform the functions described herein. A general purpose processor may be a microprocessor, but in the alternative, the processor may be any conventional processor, controller, microcontroller, or state machine. A processor may also be implemented as a combination of computing devices (e.g., a combination of a DSP and a microprocessor, a plurality of microprocessors, one or more microprocessors in conjunction with a DSP core, or any other such configuration).

[0062] Although some aspects have been described in connection with a device, it goes without saying that these aspects also constitute a description of the corresponding method, and so a block or a component of a device should also be understood as a corresponding method action or as a feature of a method action. Analogously thereto, aspects described in connection with or as a method action also constitute a description of a corresponding block or detail or feature of a corresponding device. Some or all of the method actions can be performed by a hardware apparatus (or using a hardware apparatus), such as, for example, a microprocessor, a programmable computer or an electronic circuit. In

some examples, some or a plurality of the most important method actions can be performed by such an apparatus.

[0063] In the detailed description above it can be seen that different features are grouped together in examples. This manner of disclosure should not be understood as an intention that the claimed examples have more features than are explicitly mentioned in the respective claim. Rather, the disclosure may include fewer than all features of an individual example disclosed. Therefore, the following claims should hereby be deemed to be incorporated in the description, wherein each claim by itself can stand as a separate example. Although each claim by itself can stand as a separate example, it should be noted that—although a dependent claim can refer in the claims to a specific combination with one or a plurality of claims—other examples can also encompass or include a combination of said dependent claim with the subject matter of any other dependent claim or a combination of any feature with other dependent and independent claims. Such combinations are proposed herein, unless it is explicitly expressed that a specific combination is not intended. Furthermore, it is also intended that features of a claim can be included in any other independent claim, even if said claim is not directly dependent on the independent claim.

[0064] It should furthermore be noted that methods, systems, and apparatus disclosed in the description or in the claims can be implemented by a device comprising means for performing the respective actions of this method.

[0065] Furthermore, in some examples, an individual action can be subdivided into a plurality of sub-actions or contain a plurality of sub-actions. Such sub-actions can be contained in the disclosure of the individual action and be part of the disclosure of the individual action.

[0066] While the foregoing disclosure shows illustrative examples of the disclosure, it should be noted that various changes and modifications could be made herein without departing from the scope of the disclosure as defined by the appended claims. The functions and/or actions of the method claims in accordance with the examples of the disclosure described herein need not be performed in any particular order. Additionally, well-known elements will not be described in detail or may be omitted so as to not obscure the relevant details of the aspects and examples disclosed herein. Furthermore, although elements of the disclosure may be described or claimed in the singular, the plural is contemplated unless limitation to the singular is explicitly stated.

1. A RF shielding arrangement, comprising:
 - a substrate having a first side and a second side opposite the first side;
 - a second integrated circuit device mounted on the second side of the substrate;
 - a first integrated circuit device mounted on the first side of the substrate;
 - a plurality of solder balls on the first side of the substrate proximate to a periphery of the substrate; and
 - a plurality of wire-bonds on the first side of the substrate between the plurality of solder balls and the first integrated circuit device.
2. The RF shielding arrangement of claim 1, further comprising a first plurality of signal connections between the plurality of solder balls and the plurality of wire-bonds and wherein the plurality of solder balls are configured as ground connections.

3. The RF shielding arrangement of claim 1, wherein the first integrated circuit device comprises a plurality of first integrated circuit devices and wherein the plurality of wire-bonds separates each of the plurality of first integrated circuit devices from each other of the first integrated circuit devices.

4. The RF shielding arrangement of claim 1, wherein the plurality of wire-bonds are located between proximate ones of the plurality of solder balls in a plane parallel to the first side of the substrate.

5. The RF shielding arrangement of claim 1, further comprising a printed circuit board proximate to the first side of the substrate and wherein each of the plurality of wire-bonds is attached to the printed circuit board.

6. The RF shielding arrangement of claim 1, wherein the second integrated circuit device comprises a plurality of second integrated circuit devices mounted on the second side of the substrate.

7. The RF shielding arrangement of claim 1, further comprising an encapsulant enclosing the second integrated circuit device on the second side of the substrate.

8. The RF shielding arrangement of claim 1, wherein the RF shielding arrangement is incorporated into a device selected from the group consisting of a music player, a video player, an entertainment unit, a navigation device, a communications device, a mobile device, a mobile phone, a smartphone, a personal digital assistant, a fixed location terminal, a tablet computer, a computer, a wearable device, a laptop computer, a server, and a device in an automotive vehicle.

9. A RF shielding arrangement, comprising:

a substrate having a first side and a second side opposite the first side;

a second integrated circuit device mounted on the second side of the substrate;

a first integrated circuit device mounted on the first side of the substrate;

a plurality of solder balls on the first side of the substrate proximate to a periphery of the substrate; and

means for shielding on the first side of the substrate between the plurality of solder balls and the first integrated circuit device.

10. The RF shielding arrangement of claim 9, further comprising a first plurality of signal connections between the plurality of solder balls and the means for shielding and wherein the plurality of solder balls are configured as ground connections.

11. The RF shielding arrangement of claim 9, wherein the first integrated circuit device comprises a plurality of first integrated circuit devices and wherein the means for shielding separates each of the plurality of first integrated circuit devices from each other of the first integrated circuit devices.

12. The RF shielding arrangement of claim 9, wherein the means for shielding is located between proximate ones of the plurality of solder balls in a plane parallel to the first side of the substrate.

13. The RF shielding arrangement of claim 9, further comprising a printed circuit board proximate to the first side of the substrate and wherein the means for shielding is attached to the printed circuit board.

14. The RF shielding arrangement of claim 9, wherein the second integrated circuit device comprises a plurality of second integrated circuit devices mounted on the second side of the substrate.

15. The RF shielding arrangement of claim 9, further comprising an encapsulant enclosing the second integrated circuit device on the second side of the substrate.

16. The RF shielding arrangement of claim 9, wherein the RF shielding arrangement is incorporated into a device selected from the group consisting of a music player, a video player, an entertainment unit, a navigation device, a communications device, a mobile device, a mobile phone, a smartphone, a personal digital assistant, a fixed location terminal, a tablet computer, a computer, a wearable device, a laptop computer, a server, and a device in an automotive vehicle.

17. A method for making a RF shielding arrangement, the method comprising:

mounting a first integrated circuit device on a first side of a substrate;

mounting a second integrated circuit device on a second side of the substrate opposite the first side of the substrate;

mounting a plurality of solder balls on the first side of the substrate proximate to a periphery of the substrate; and mounting a plurality of wire-bonds on the first side of the substrate between the plurality of solder balls and the first integrated circuit device.

18. The method for making a RF shielding arrangement of claim 17, further comprising mounting a first plurality of signal connections between the plurality of solder balls and the plurality of wire-bonds and wherein the plurality of solder balls are configured as ground connections.

19. The method for making a RF shielding arrangement of claim 17, wherein the first integrated circuit device comprises a plurality of first integrated circuit devices and wherein the plurality of wire-bonds separates each of the plurality of first integrated circuit devices from each other of the first integrated circuit devices.

20. The method for making a RF shielding arrangement of claim 17, wherein the plurality of wire-bonds are located between proximate ones of the plurality of solder balls in a plane parallel to the first side of the substrate.

21. The method for making a RF shielding arrangement of claim 17, further comprising mounting the first side of the substrate to a printed circuit board and mounting each of the plurality of wire-bonds to the printed circuit board.

22. The method for making a RF shielding arrangement of claim 17, wherein the second integrated circuit device comprises a plurality of second integrated circuit devices mounted on the second side of the substrate.

23. The method for making a RF shielding arrangement of claim 17, further comprising enclosing the second integrated circuit device on the second side of the substrate with an encapsulant.

24. The method for making a RF shielding arrangement of claim 17, wherein the method is incorporated into a device selected from the group consisting of a music player, a video player, an entertainment unit, a navigation device, a communications device, a mobile device, a mobile phone, a smartphone, a personal digital assistant, a fixed location terminal, a tablet computer, a computer, a wearable device, a laptop computer, a server, and a device in an automotive vehicle.

25. A RF shielding arrangement, comprising:
a substrate having a first side and a second side opposite the first side;
a second integrated circuit device mounted on the second side of the substrate;
a first integrated circuit device mounted on the first side of the substrate;
a plurality of solder balls on the first side of the substrate proximate to a periphery of the substrate; and
a plurality of wire-bonds on the first side of the substrate between the plurality of solder balls, one of the plurality of wire-bonds between each of proximate ones of the plurality of solder balls.

26. The RF shielding arrangement of claim **25**, wherein alternating ones of the plurality of solder balls are configured as a first plurality of signal connections between alternating ones configured as ground connections.

27. The RF shielding arrangement of claim **25**, wherein the first integrated circuit device comprises a plurality of first integrated circuit devices and wherein the plurality of wire-bonds separates each of the plurality of first integrated circuit devices from each other of the first integrated circuit devices.

28. The RF shielding arrangement of claim **25**, further comprising a printed circuit board proximate to the first side of the substrate and wherein each of the plurality of wire-bonds is attached to the printed circuit board.

29. The RF shielding arrangement of claim **25**, wherein the second integrated circuit device comprises a plurality of second integrated circuit devices mounted on the second side of the substrate.

30. The RF shielding arrangement of claim **25**, further comprising an encapsulant enclosing the second integrated circuit device on the second side of the substrate.

* * * * *