

(19) World Intellectual Property Organization
International Bureau



(43) International Publication Date
17 July 2003 (17.07.2003)

PCT

(10) International Publication Number
WO 03/057295 A1

(51) International Patent Classification⁷: **A61M 16/00**,
16/04, 39/00, 39/10, F16L 37/00, 37/08, 37/23, 37/24,
37/248, 37/252, 37/02

(21) International Application Number: PCT/US02/31698

(22) International Filing Date: 4 October 2002 (04.10.2002)

(25) Filing Language: English

(26) Publication Language: English

(30) Priority Data:
10/036,748 21 December 2001 (21.12.2001) US

(71) Applicant: **KIMBERLY-CLARK WORLDWIDE, INC.** [US/US]; 401 N. Lake Street, Neenah, WI 54956 (US).

(72) Inventors: **MADSEN, Edward, B.**; 12707 South Rosberg Drive, Riverton, UT 84065 (US). **CISE, David, M.**; 16162 South Step Side Road, Herriman, UT 84065 (US).

(74) Agents: **PIEROTTI, Neal, P.**; Dority & Manning, P.A., One Liberty Square, 55 Beattie Place, Suite 1600, Greenville, SC 29601 et al. (US).

(81) Designated States (*national*): AE, AG, AL, AM, AT, AU, AZ, BA, BB, BG, BR, BY, BZ, CA, CH, CN, CO, CR, CU, CZ, DE, DK, DM, DZ, EC, EE, ES, FI, GB, GD, GE, GH, GM, HR, HU, ID, IL, IN, IS, JP, KE, KG, KP, KR, KZ, LC, LK, LR, LS, LT, LU, LV, MA, MD, MG, MK, MN, MW, MX, MZ, NO, NZ, OM, PH, PL, PT, RO, RU, SD, SE, SG, SI, SK, SL, TJ, TM, TN, TR, TT, TZ, UA, UG, UZ, VC, VN, YU, ZA, ZM, ZW.

(84) Designated States (*regional*): ARIPO patent (GH, GM, KE, LS, MW, MZ, SD, SL, SZ, TZ, UG, ZM, ZW), Eurasian patent (AM, AZ, BY, KG, KZ, MD, RU, TJ, TM), European patent (AT, BE, BG, CH, CY, CZ, DE, DK, EE, ES, FI, FR, GB, GR, IE, IT, LU, MC, NL, PT, SE, SK, TR), OAPI patent (BF, BJ, CF, CG, CI, CM, GA, GN, GQ, GW, ML, MR, NE, SN, TD, TG).

Declarations under Rule 4.17:

- as to applicant's entitlement to apply for and be granted a patent (Rule 4.17(ii)) for all designations
- as to the applicant's entitlement to claim the priority of the earlier application (Rule 4.17(iii)) for all designations

Published:

- with international search report

For two-letter codes and other abbreviations, refer to the "Guidance Notes on Codes and Abbreviations" appearing at the beginning of each regular issue of the PCT Gazette.

(54) Title: MEDICAL CONNECTOR FOR A RESPIRATORY ASSEMBLY

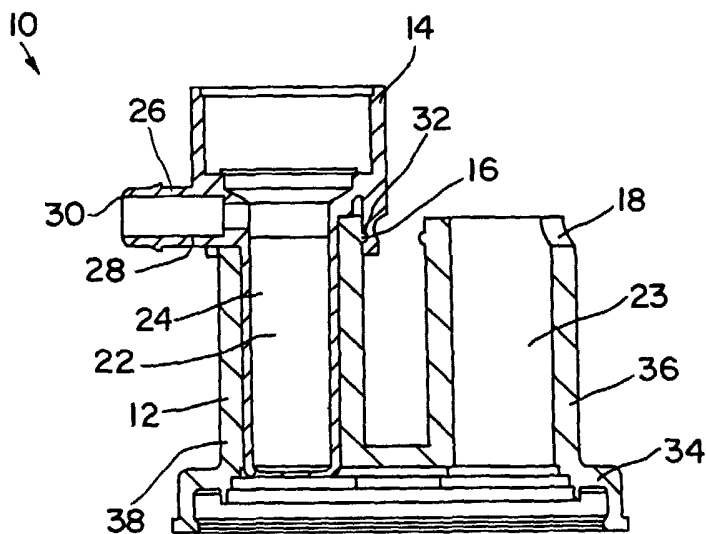

(57) Abstract: A connection assembly (10) for use with a respiratory circuit assembly is provided. The connection assembly includes a first connection member (12) that has an opening therethrough to allow for the transport of fluids and objects through the first connection member (12). The first connection member has a recess on an end thereof. A second connection member (14) is present that is releaseably engageable with the first connection member (12). The second connection member (14) has an opening therethrough to allow for the transport of fluids and objects through the second connection member (14). The second connection member (14) has a disconnect member (16, 32) may be present on at least one of the first and second connection members (12, 14). The snap fit (16, 32) member hinders unintentional disengagement of the first and second connection members (12, 14). Relative movement between the first

connection member and the disconnect member causes a separation of the first and second connection members (12, 14).



WO 03/057295 A1

Title of the Invention

MEDICAL CONNECTOR FOR A RESPIRATORY ASSEMBLY

Background

Endotracheal intubation is a common procedure in the field of respiratory medical care. Endotracheal intubation tubes are used in many situations for providing artificial airways for passage of respiratory gasses and medical procedure
5 devices to patients. For instance, endotracheal tubes may be used to insert a catheter therethrough in order to clean lung secretions from a patient. Endotracheal tubes may be used in situations where patients have stopped independent breathing and are required to be supported on a ventilator. In addition, endotracheal tubing may be used for other procedures such as:
10 oxygenation of the lungs; elimination or reduction of residual carbon dioxide from the lungs; visual inspection of portions of the respiratory system; sampling sputum and gasses; measuring parameters such as flow rates, pressure, and temperature of gasses within the respiratory system; and/or the administration of medication, gasses, and/or lavage.

15 All of these procedures require various instruments to be used in conjunction with the respiratory circuit. In addition, other equipment may be incorporated into the circuit. For example, some respiratory circuits include a humidifier. Humidifiers are advantageous because breathing gasses supplied to a patient must be warm and humidified in order to provide quality inhalation
20 therapy. A humidifier is typically connected in the breathing circuit between the ventilator and the patient. Air from the ventilator is warmed and moisturized by the humidifier and then is supplied to the patient. Due to the fact that various instruments and pieces of equipment must be connected and reconnected to the respiratory circuit, connectors are often employed in such circuits.

25 Connectors are often permanently bonded to instruments and manifolds in respiratory circuits. This type of attachment is advantageous because a secure and fluid-tight fit is provided. However, permanently bonding an instrument or other piece of equipment in a respiratory circuit has inherent disadvantages. For

instance, an instrument that is permanently bonded to a connector cannot be removed therefrom and must be replaced oftentimes increasing the cost of the medical treatment. Further, permanently bonding a diagnostic instrument to a connector may prevent the clinician from performing some other type of procedure
5 on the patient during ventilation of the patient. Additionally, damage of an instrument or piece of equipment that is permanently bonded to a connector may necessitate the replacement of several components of the respiratory circuit.

Connectors which are detachable have been used in order to overcome the problems associated with permanently bonded connectors in respiratory circuits. A
10 detachable connector allows for various instruments and pieces of equipment to be interchanged in a respiratory breathing circuit. As such, the respiratory breathing circuit can be configured to provide for an increased number of procedures. Additionally, the ability to remove instruments from the breathing apparatus may allow for the instrument to be cleaned, hence reducing the costs associated with
15 the procedure.

However, problems with disconnect medical connectors do exist. Typically, such connectors are interference-fit connectors. For instance, a fitting on a catheter may be connected to a complimentary fitting on a manifold of a respiratory breathing circuit by forcing one fitting onto the other. The catheter is
20 then held onto the manifold via an interference fit between the two fittings. Since the connection is not a permanent connection, air or other fluids may leak through this interference-fit connection. Additionally, if the fittings of interference-fit connectors are not adequately pressed against one another, forces could act on the connection to accidentally disconnect the connection. Obviously, such a result
25 is unacceptable. Also, multiple fittings which are connected together via an interference fit may sometimes be difficult for a doctor or caregiver to disconnect when it is necessary to remove the surgical instrument. One example of an interference-fit connector is shown in U.S. Patent No. 5,820,614.

The present invention improves the general type of medical connectors currently employed, and further addresses the need in the medical field for an improved medical connector for use with a respiratory breathing circuit.

5

Summary

Objects and advantages of the invention will be set forth in part in the following description, or may be obvious from the description, or may be learned through practice of the invention.

The present invention provides for a connection assembly that is used with a respiratory circuit assembly. The connection assembly includes a cylindrical first connection member that has a bore therethrough. The first connection member is configured for engagement with a first respiratory circuit member and allows for transport of fluids and objects therethrough. The first connection member has a locking member that is located thereon for engagement with a second connection member to prevent disengagement between the first and second connection members. In one embodiment, this locking member includes a recess on one end of the first connection member. A portion of the recess defines at least one ramp on the first connection member.

A second connection member is present that has a cylindrical body with a bore therethrough. The second connection member allows for the transport of fluids and objects therethrough, and is configured for engagement with a second respiratory circuit member. The second connection member has a disconnect member with a curved surface at least where the disconnect member is located in the recess during engagement between the locking member and the first connection member. Relative rotation between the first connection member and the second connection member causes the curved surface to move along the ramp. This effects disengagement of the locking member and the first connection member, and causes separation of the first and second connection members.

The present invention also includes a connection assembly as immediately discussed where the disconnect member is a cylindrical irrigation port.

Further, the present invention includes a connection assembly as previously discussed where the locking member includes a locking ring that substantially surrounds the circumference of the first connection member. The locking ring is located proximate to the recess of the first connection member. The second
5 connection member has a groove for engaging the locking ring and acting with the locking ring to prevent disengagement between the second connection member and the first connection member.

The present invention also includes a connection assembly as immediately discussed where the disconnect member has at least part of the surface being
10 curved where the disconnect member engages along the ramped surface.

Further included in the present invention is a connection assembly as previously discussed where the disconnect member is a substantially cylindrical irrigation port.

Further included in the present invention is an exemplary embodiment as
15 previously discussed where the locking member is at least one barb located on one of the first and second connection members.

In one embodiment of the connection assembly, a snap fit member is present on at least one of the first and second connection members. The snap fit member hinders unintentional disengagement of the first and second connection
20 members. Relative movement between the first connection member and the disconnect member motivates a separation of the first and second connection members.

Further included in the present invention is an exemplary embodiment as previously mentioned where the snap fit member is at least one barb located on
25 the second connection member.

Additionally, the present invention includes an embodiment as previously discussed where the snap fit member is a locking ring that substantially surrounds the first connection member. The second connection member has a groove for receiving the locking ring to hinder disengagement of the first and second
30 connection members.

Brief Description of the Drawings

An embodiment of the present invention is described by way of example with reference to the accompanying drawings, in which:

5 Fig. 1 is a bottom plan view of an exemplary embodiment of a first connection member in accordance with the present invention. The drawing shows two ports located on a rotatable manifold.

 Fig. 2 is a cross-sectional elevation view of an exemplary embodiment of a connection assembly in accordance with the present invention. The drawing
10 shows a first connection member engaged with a second connection member by use of a locking member.

 Fig. 3 is a cross-sectional elevational view of an exemplary embodiment of the second connection member in accordance with the present invention. The drawing shows a barb located on one end of the second connection member.

15 Fig. 4 is a cross-sectional elevation view of an exemplary embodiment of the first connection member in accordance with the present invention. The drawing shows the rotatable manifold having two ports with locking members on both of the ports.

 Fig. 5 is an elevation view of an exemplary embodiment of a first
20 connection member in accordance with the present invention. The drawing shows a recess defining a ramp on one end of the first connection member and proximate to the locking member.

 Fig. 6 is a cross-sectional elevation view of an exemplary embodiment of a first connection member in accordance with the present invention. The drawing
25 shows a rotatable manifold having two ports with locking members and recesses on both of the ports.

Detailed Description

Reference will now be made in detail to embodiments of the invention, one
30 or more examples of which are illustrated in the drawings. Each example is

provided by way of explanation of the invention, and not meant as a limitation of the invention. For example, features illustrated or described as part of one embodiment can be used with another embodiment to yield still a third embodiment. It is intended that the present invention include these and other
5 modifications and variations.

An exemplary embodiment of a connection assembly 10 is shown in Fig. 2. The connection assembly 10 includes a first connection member 12 that is engaged with a second connection member 14. The connection assembly 10 is designed to include both a positive locking engagement between the first and
10 second connection members 12 and 14 along with a way of disengaging the locking arrangement by rotating the first and second connection members 12 and 14 relative to one another. Such an arrangement is advantageous because the connection assembly 10 will only be disengaged when desired by a user, and not disengaged by accident. Additionally, relative rotation between the first and
15 second connection members 12 and 14 provides for a way of disengaging the connection assembly 10 without requiring a user to exert substantial force.

The first connection member 12 is shown in Fig. 2 as being a rotatable manifold 34. The rotatable manifold 34 may be incorporated into a respiratory circuit in order to permit access to the respiratory circuit through various ports.
20 The rotatable manifold 34 shown in Fig. 2 has two ports 36 and 38 located thereon. In other exemplary embodiments of the present invention, the rotatable manifold 34 may be supplied as the first connection member 12 with a varying number of ports located thereon. Additionally, other exemplary embodiments of the present invention include a first connection member 12 that has only one port
25 located thereon. A rotatable manifold 34 is known from U.S. Patent No. 5,735,271 which is assigned to the assignee of the current application and is incorporated herein for all purposes in its entirety. The rotatable manifold 34 allows for the access of the respiratory circuit by a medical caregiver through different ports which may be sized and configured to accept various medical instruments and
30 fluids. Other exemplary embodiments exist where the connection assembly 10 is

not incorporated with a rotatable manifold 34, but incorporated with other components of the respiratory circuit.

Shown engaged with the first connection member 12 in Fig. 2 is the second connection member 14. The connection between the first and second connection members 12 and 14 is effected by a groove 32 and locking member 16. The locking member 16 is located on one end of port 38 of the first connection member 12. The locking member 16 is simply a projection that extends substantially around the circumference of the port 38. Groove 32 is located substantially around the circumference of a section of the second connection member 14. The groove 32 and the locking member 16 are sized in such a way that engagement between the two causes a "snap-fit" connection. This connection prevents the first and second connection members 12 and 14 from separating from one another during normal use of the respiratory circuit. Therefore, the connection assembly 10 will not become disengaged during normal use, and will only become disengaged when desired by a medical caregiver.

Fig. 1 is a bottom plan view of a first connection member 12 being a rotatable manifold 34 with two ports 36 and 38 located thereon. A first opening of the connection member 22 and a second opening of the first connection member 23 are located through ports 36 and 38. These openings 22 and 23 allow for the transport of fluids and medical devices into and out of the respiratory circuit. It is to be understood that in the present application, the word "port" is defined to be a member that has an opening therethrough. Both the opening and the member can be of any shape. The member is configured to allow for the passage of fluids and/or medical devices to and from the respiratory circuit.

Fig. 3 shows an exemplary embodiment of a second connection member in accordance with the present invention. Here, a barb 40 is located on one end of the second connection member 14. The barb 40 is designed to engage a barb locking surface 42 of the first connection member 12 as shown in Fig. 4. In this exemplary embodiment, insertion of the second connection member 14 into the opening of the first connection member 22 causes the barb 40 to be compressed.

Once the barb 40 clears the length of the first opening of the first connection member 22, the barb 40 snaps into place onto the barb locking surface 42. This in effect causes a positive locking connection between the first and second connection members 12 and 14. This arrangement can be thought of as a "snap-fit" connection. The use of a barb 40 to effect the locking of the connection assembly 10 may be substituted for or used in addition to the use of a locking member 16 in combination with a groove 32 to effect the locking of the connection assembly 10. As such, exemplary embodiments of the present invention may include exemplary embodiments that include only a barb 40, a locking member 16, or both locking member 16 and barb 40. Additionally, other exemplary embodiments of the present invention may include members that form a positive locking arrangement between the first and second connection members 12 and 14 that are known in the art.

In order to disengage the first connection member 12 from the second connection member 14, a disconnect member 26 is provided. The exemplary embodiments shown in Figs. 2 and 3 show a disconnect member 26 that is an irrigation port 30 having a cylindrical surface 28. In other exemplary embodiments of the present invention, only a semi-cylindrical surface 28 is present. Additionally, other exemplary embodiments of the present invention include a disconnect member 26 that has only a partially curved surface. Also, the disconnect member 26 does not have to be an irrigation port 30, but may simply be a lug or other member. An advantage of using the irrigation port 30 as the disconnect member 26 is that the irrigation port 30 may be used for another function such as the introduction of lavage into the respiratory circuit.

Fig. 5 shows an exemplary embodiment of the first connection member 12 in accordance with the present invention. More particularly, Fig. 5 shows a recess 18 being located on one end of a port 38 of the rotatable manifold 34. Recess 18 is curved in order to receive the cylindrical surface 28 of the second connection member 14 of Fig. 3. Additionally, recess 18 in Fig. 5 defines a ramp 20. In the exemplary embodiment shown in Fig. 5, ramp 20 extends to the end of the port

38. The locking member 16 is a locking ring that substantially surrounds port 38, but does not completely surround port 38. The locking member 16 is interrupted in the vicinity of the recess 18. During engagement between the first and second connection members 12 and 14, the disconnect member 26 is inserted into the
5 recess 18, and seats against the port 38. Recess 18 is sized and shaped in order to accept the cylindrical surface 38 of the irrigation port 30. Groove 32 is fit around the locking member 16 and the combination of the two securely holds the first and second connection members 12 and 14 against one another.

To disengage the connection assembly 10, a user will rotate the first and
10 second connection members 12 and 14 with respect to one another such that the disconnect member 26 is pushed against the ramp 20. The cylindrical surface 28 of the irrigation port 30 is then urged against ramp 20 and moves against ramp 20. This movement results in a force that has a component in the direction of arrow A in Fig. 5. This force then causes the locking member 16 to be disengaged
15 from the groove 32 and allows the first connection member 12 to be removed from the second connection member 14. As such, the exemplary embodiment shown in Fig. 5 has a first connection member 12 that is disengaged from the second connection member 14 upon clockwise rotation of the second connection member 14 with respect to the first connection member 12. However,
20 other exemplary embodiments of the present invention exist where the ramp 20 is positioned opposite to the position shown in Fig. 5 such that the first connection member 12 is disengaged via counterclockwise rotation of the second connection member 14. In addition, other exemplary embodiments exist where the recess 18 defines two ramps 20 on the port 38 of the rotatable manifold 34. Here, a user
25 can disengage the first and second connection members 12 and 14 by rotating them relative to one another in either direction.

Fig. 6 shows another exemplary embodiment of the present invention where a first connection member 12 has two ports 36 and 38 both having a locking member 16 and a recess 18 defined on one end. As such, the connection

assembly 10 may be included in all of the ports of the rotatable manifold 34 and not only on a single port of the rotatable manifold 34.

5 Additionally, the fit between the first and second connection members 12 and 14 may be tight enough in other exemplary embodiments of the present invention such that a seal is formed between the first and second connection members 12 and 14. A taper may be provided on one of the connection members 12 and 14 to effect this seal in other exemplary embodiments.

10 It should be understood that the invention includes various modifications that can be made to the exemplary embodiments of the medical connector for a respiratory circuit as described herein as come within the scope of the appended claims and their equivalents.

Claims

What is claimed is:

1. A connection assembly for use with a respiratory circuit assembly, comprising:

a first connection member and a second connection member;

5 said first connection member being generally cylindrical and having a bore therethrough, said first connection member allowing for transport of fluids and objects therethrough, said first connection member having a locking member located thereon for engagement with said second connection member to prevent disengagement between said second connection member and said first connection member, said first connection member having a recess on one end, a portion of
10 said recess defining at least one ramp, said first connection member being configured for engagement with a first respiratory circuit member; and

said second connection member having a cylindrical body with a bore therethrough, said second connection member allowing for the transport of fluids and objects therethrough, said second connection member being configured for
15 engagement with a second respiratory circuit member, said second connection member having a disconnect member with a curved surface at least where said disconnect member is located in said recess during engagement between said locking member and said first connection member, wherein relative rotation between said first connection member and said second connection member causes
20 said curved surface to move along said ramp to effect disengagement of said locking member and said first connection member and causes separation of said first connection member and said second connection member.

2. The connection assembly of claim 1, wherein said disconnect member is a cylindrical irrigation port.

3. The connection assembly of claim 1, wherein said disconnect member is a

semi-cylindrical lug.

4. The connection assembly of claim 1, wherein said locking member is a locking ring that substantially surrounds the circumference of said first connection member, said locking ring is located proximate to said recess of said first connection member, wherein said second connection member has a groove for
5 engaging said locking ring and acting with said locking ring to prevent disengagement between said second connection member and said first connection member.

5. The connection assembly of claim 1, wherein said recess of said first connection member defines two ramps.

6. The connection assembly of claim 1, wherein the first respiratory circuit member is a rotatable manifold having at least two ports, and wherein the second respiratory circuit member is an aspirating catheter assembly.

7. The connection assembly of claim 1, wherein one of said first connection members and said second connection member has a tapered surface to create a seal between said first and second connection members.

8. A connection assembly for use with a respiratory circuit assembly, comprising:

a first connection member having an opening therethrough to allow for the transport of fluids and objects through said first connection member, said first
5 connection member having a recess on one end, said recess defining at least one ramped surface;

a second connection member having an opening therethrough to allow for the transport of fluids and objects through said second connection member, said second connection member engageable with said first connection member and

- 10 having a disconnect member engageable within said recess;
a locking member configured on at least one of said first connection member and said second connection member, said locking member preventing disengagement of said first and second connection members when said first and second connection members are engaged with one another; and
- 15 wherein rotational movement of said disconnect member along said ramp effects disengagement of said locking member and separation of said first and second connection members.

9. The connection assembly of claim 8, wherein said disconnect member has at least part of the surface of said disconnect member being curved, where said disconnect member engages along said ramped surface.

10. The connection assembly of claim 8, wherein said disconnect member is a substantially cylindrical irrigation port.

11. The connection assembly of claim 8, wherein said locking member is a locking ring, during at least engagement of said first and second connection members said locking ring is proximate to said recess of said first connection member.

12. The connection assembly of claim 8, wherein:

said locking member is configured on said first connection member, said locking member is a locking ring that substantially surrounds said first connection member, said locking ring is proximate to said recess of said first connection member; and

5

wherein said second connection member has a groove for receiving said locking ring, said groove and said locking ring act to prevent disengagement of said first and second connection members when said first and second connection members are engaged with one another.

13. The connection assembly of claim 8, wherein said locking member is at least one barb located on one of said first and second connection members.

14. The connection assembly of claim 8, wherein said disconnect member is a lug having at least a partially curved surface where said disconnect member engages along said ramped surface.

15. The connection assembly of claim 9, wherein said disconnect member is a substantially cylindrical irrigation port.

16. The connection assembly of claim 8, wherein one of said first connection members and said second connection member has a tapered surface to create a seal between said first and second connection members.

17. A connection assembly for use with a respiratory circuit assembly, comprising:

a first connection member having an opening therethrough to allow for the transport of fluids and objects through said first connection member, said first connection member having a recess;

a second connection member releaseably engageable with said first connection member and having an opening therethrough to allow for the transport of fluids and objects through said second connection member, said second connection member having a disconnect member engageable within said recess;

a snap fit member on at least one of said first and second connection members, said snap fit member preventing unintentional disengagement of said first and second connection members; and

wherein relative movement between said first connection member and said disconnect member motivates a separation of said first and second connection members.

18. The connection assembly of claim 17, wherein said recess defines at least one ramped surface and wherein said disconnect member slides on said ramped surface upon engagement and disengagement of said connection members.
19. The connection assembly of claim 17, wherein said snap fit member is at least one barb located on said second connection member.
20. The connection assembly of claim 17, wherein said snap fit member is a locking ring that at least substantially surrounds the first connection member, and wherein said second connection member has a groove for receiving said locking ring to hinder disengagement of said first and second connection members.
21. The connection assembly of claim 17, wherein said disconnect member is a substantially cylindrical irrigation port.

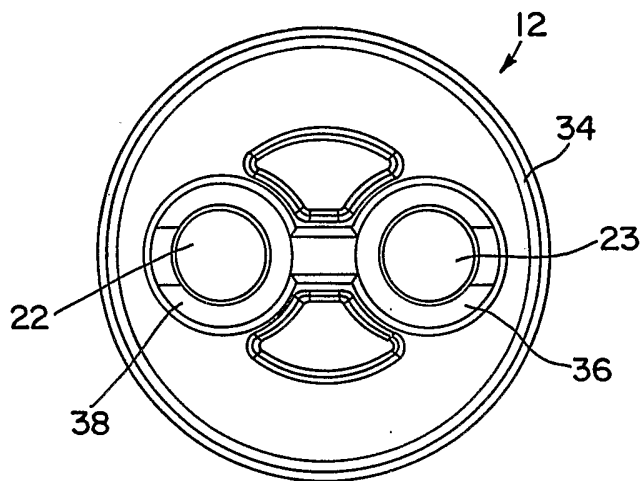

FIG. 1

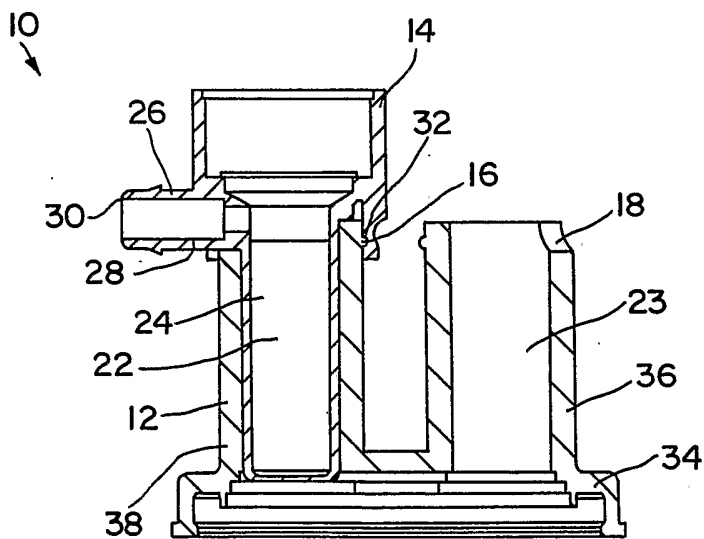

FIG. 2

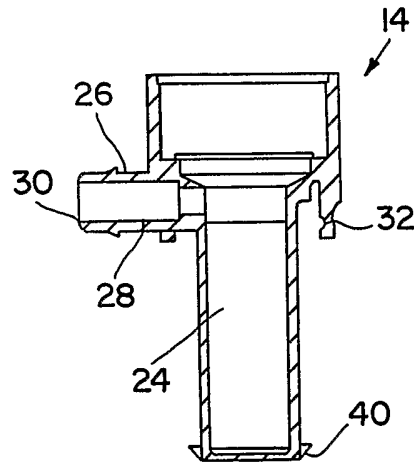

FIG. 3

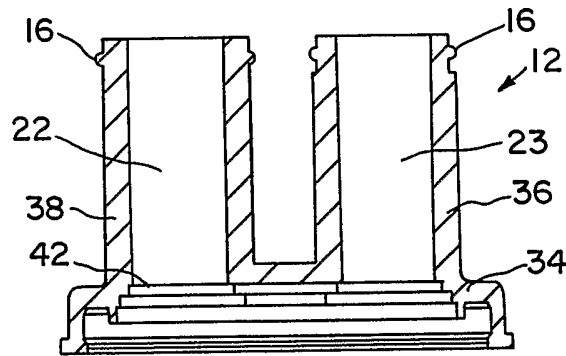

FIG. 4

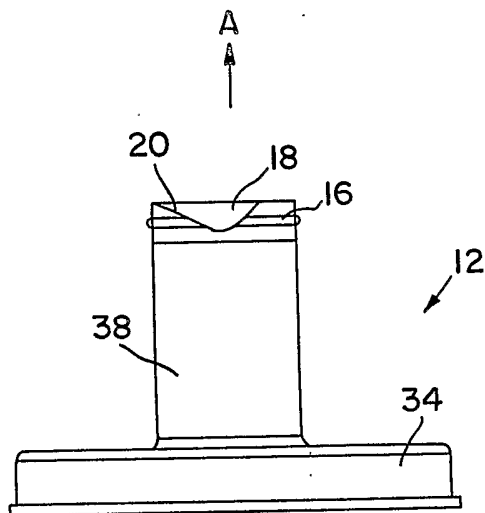

FIG. 5

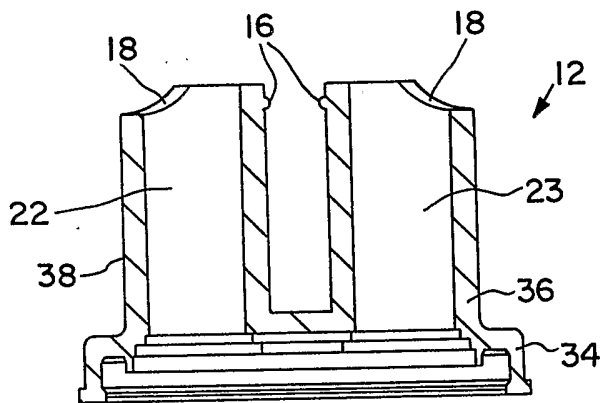

FIG. 6

INTERNATIONAL SEARCH REPORT

International Application No

PCT/US 02/31698

A. CLASSIFICATION OF SUBJECT MATTER

IPC 7 A61M16/00 A61M16/04 A61M39/00 A61M39/10 F16L37/00
 F16L37/08 F16L37/23 F16L37/24 F16L37/248 F16L37/252
 F16L37/02

According to International Patent Classification (IPC) or to both national classification and IPC

B. FIELDS SEARCHED

Minimum documentation searched (classification system followed by classification symbols)

IPC 7 A61M F16L

Documentation searched other than minimum documentation to the extent that such documents are included in the fields searched

Electronic data base consulted during the international search (name of data base and, where practical, search terms used)

EPO-Internal

C. DOCUMENTS CONSIDERED TO BE RELEVANT

Category °	Citation of document, with indication, where appropriate, of the relevant passages	Relevant to claim No.
A	US 5 820 614 A (ERSKINE TIMOTHY J ET AL) 13 October 1998 (1998-10-13) cited in the application	1-16
X	abstract; figures 3-4A,6-7A column 2, line 20-41 column 4, line 42 -column 5, line 34 column 6, line 32 -column 7, line 5 ---	17-21
A	US 4 406 485 A (GIEBELER BEN F) 27 September 1983 (1983-09-27) abstract; figures column 1, line 12-22 column 2, line 48-56 --- -/--	1-21

Further documents are listed in the continuation of box C.

Patent family members are listed in annex.

° Special categories of cited documents :

- *A* document defining the general state of the art which is not considered to be of particular relevance
- *E* earlier document but published on or after the international filing date
- *L* document which may throw doubts on priority claim(s) or which is cited to establish the publication date of another citation or other special reason (as specified)
- *O* document referring to an oral disclosure, use, exhibition or other means
- *P* document published prior to the international filing date but later than the priority date claimed

- *T* later document published after the international filing date or priority date and not in conflict with the application but cited to understand the principle or theory underlying the invention
- *X* document of particular relevance; the claimed invention cannot be considered novel or cannot be considered to involve an inventive step when the document is taken alone
- *Y* document of particular relevance; the claimed invention cannot be considered to involve an inventive step when the document is combined with one or more other such documents, such combination being obvious to a person skilled in the art.
- *Z* document member of the same patent family

Date of the actual completion of the international search

14 January 2003

Date of mailing of the international search report

22/01/2003

Name and mailing address of the ISA

European Patent Office, P.B. 5818 Patentlaan 2
 NL - 2280 HV Rijswijk
 Tel. (+31-70) 340-2040, Tx. 31 651 epo nl,
 Fax: (+31-70) 340-3016

Authorized officer

Lager, J

INTERNATIONAL SEARCH REPORT

Int. Application No
PCT/US 02/31698

C.(Continuation) DOCUMENTS CONSIDERED TO BE RELEVANT		
Category °	Citation of document, with indication, where appropriate, of the relevant passages	Relevant to claim No.
A	<p>US 5 735 271 A (HOOSER DAVID THERON VAN ET AL) 7 April 1998 (1998-04-07) abstract; figures 8-16 column 2, line 53-61 column 3, line 57-67 column 5, line 44-58 column 7, line 8-18 column 13, line 48-58 column 15, line 42 -column 17, line 14 -----</p>	1-21
A	<p>WO 91 01120 A (TEKNOPLAST AS) 7 February 1991 (1991-02-07) abstract; figures page 3, line 13-27 page 5, line 10 -page 6, line 2 -----</p>	1-21
A	<p>US 4 152 017 A (ABRAMSON HARVEY J) 1 May 1979 (1979-05-01) abstract; figures column 2, line 5 -column 3, line 40 -----</p>	
A	<p>US 6 248 099 B1 (BELL CRAIG J) 19 June 2001 (2001-06-19) abstract; figures -----</p>	

INTERNATIONAL SEARCH REPORT

 Int. Patent Application No
 PCT/US 02/31698

Patent document cited in search report		Publication date	Patent family member(s)	Publication date
US 5820614	A	13-10-1998	US 5848997 A US 6146374 A CA 2199575 A1 EP 0795342 A2 JP 3158068 B2 JP 9327519 A	15-12-1998 14-11-2000 15-09-1997 17-09-1997 23-04-2001 22-12-1997
US 4406485	A	27-09-1983	CA 1175463 A1	02-10-1984
US 5735271	A	07-04-1998	AU 2273395 A EP 0812220 A1 WO 9626757 A1 AU 1937295 A AU 1990895 A AU 2092495 A WO 9531240 A1 WO 9531249 A1 WO 9531250 A1 US 5694922 A US 5730123 A	18-09-1996 17-12-1997 06-09-1996 05-12-1995 05-12-1995 05-12-1995 23-11-1995 23-11-1995 23-11-1995 09-12-1997 24-03-1998
WO 9101120	A	07-02-1991	DK 70988 A WO 9101120 A1	12-08-1989 07-02-1991
US 4152017	A	01-05-1979	NONE	
US 6248099	B1	19-06-2001	NONE	