



US010472579B2

(12) **United States Patent**
Al-Ghamdi

(10) **Patent No.:** **US 10,472,579 B2**
(45) **Date of Patent:** **Nov. 12, 2019**

(54) **PROCESS AND SYSTEM FOR CONVERSION OF CRUDE OIL TO PETROCHEMICALS AND FUEL PRODUCTS INTEGRATING VACUUM GAS OIL HYDROCRACKING AND STEAM CRACKING**

(71) Applicant: **Saudi Arabian Oil Company**, Dhahran (SA)

(72) Inventor: **Mohammed Saeed Al-Ghamdi**, Dammam (SA)

(73) Assignee: **Saudi Arabian Oil Company**, Dhahran (SA)

(*) Notice: Subject to any disclaimer, the term of this patent is extended or adjusted under 35 U.S.C. 154(b) by 122 days.

(21) Appl. No.: **15/817,128**

(22) Filed: **Nov. 17, 2017**

(65) **Prior Publication Data**

US 2018/0142166 A1 May 24, 2018

Related U.S. Application Data

(60) Provisional application No. 62/424,883, filed on Nov. 21, 2016, provisional application No. 62/450,018, filed on Jan. 24, 2017, provisional application No. 62/450,062, filed on Jan. 24, 2017, provisional application No. 62/450,043, filed on Jan. 24, 2017, provisional application No. 62/450,031, filed on Jan. 24, 2017.

(51) **Int. Cl.**

C10G 7/00 (2006.01)
C10G 7/06 (2006.01)
C10G 47/00 (2006.01)
C10G 47/32 (2006.01)
C10G 69/14 (2006.01)
C10G 55/06 (2006.01)
C10G 47/02 (2006.01)
B01D 3/14 (2006.01)

(52) **U.S. Cl.**

CPC **C10G 55/06** (2013.01); **B01D 3/14** (2013.01); **C10G 7/00** (2013.01); **C10G 47/02** (2013.01); **C10G 2300/104** (2013.01); **C10G 2300/1051** (2013.01); **C10G 2300/1055** (2013.01); **C10G 2300/1059** (2013.01); **C10G 2400/20** (2013.01)

(58) **Field of Classification Search**

CPC . C10G 7/00; C10G 7/06; C10G 47/00; C10G 47/32; C10G 69/14; B01D 3/14
See application file for complete search history.

(56) **References Cited**

U.S. PATENT DOCUMENTS

3,472,909 A 10/1969 Raymond et al.
3,702,292 A * 11/1972 Burich C10G 9/005
208/80
3,842,138 A 10/1974 Chahvekilian et al.

3,855,113 A 12/1974 Gould
3,898,299 A 8/1975 Jones
4,065,379 A 12/1977 Soonawala et al.
4,115,467 A 9/1978 Fowler
4,180,453 A 12/1979 Franck et al.
5,906,728 A 5/1999 Iaccino et al.
5,980,732 A 11/1999 Gillis
5,981,818 A 11/1999 Purvis et al.
6,166,279 A 12/2000 Schwab et al.
6,210,561 B1 4/2001 Bradow et al.
6,538,168 B1 3/2003 Schwab et al.
7,550,642 B2 6/2009 Powers
7,938,952 B2 5/2011 Coylar et al.
8,394,900 B2 3/2013 Abhari
8,529,753 B2 9/2013 Niu et al.
8,540,870 B2 9/2013 McGehee et al.
8,722,950 B2 5/2014 Hal et al.
8,754,277 B2 6/2014 Vijayakumari et al.
8,936,716 B2 1/2015 Hoehn et al.
8,940,950 B2 1/2015 Ellrich et al.
9,273,256 B2 3/2016 Gillis et al.
9,452,955 B2 9/2016 Sieli et al.
9,464,240 B2 10/2016 Bridges et al.
9,550,707 B2 1/2017 Schrod et al.
9,650,580 B2 5/2017 Merdrignac et al.
9,856,425 B2 1/2018 Ward et al.
9,862,898 B2 * 1/2018 Ward C10G 35/00
9,920,263 B2 3/2018 Klein et al.
2004/0054247 A1 3/2004 Powers
2007/0090018 A1 4/2007 Keusenkothen et al.
2007/0232846 A1 10/2007 Baumgartner et al.

(Continued)

FOREIGN PATENT DOCUMENTS

CA 2674212 C 4/2015
CN 103374395 B 7/2015

(Continued)

OTHER PUBLICATIONS

PCT/US2017/062563, International Search Report and Written Opinion dated Jan. 26, 2018, 14 pages.

Primary Examiner — Randy Boyer

(74) *Attorney, Agent, or Firm* — Abelman, Frayne and Schwab

(57) **ABSTRACT**

Process scheme configurations are disclosed that enable conversion of crude oil feeds with several processing units in an integrated manner into petrochemicals. The designs utilize minimum capital expenditures to prepare suitable feedstocks for the steam cracker complex. The integrated process for converting crude oil to petrochemical products including olefins and aromatics, and fuel products, includes mixed feed steam cracking and gas oil steam cracking. Feeds to the mixed feed steam cracker include light products and naphtha from hydroprocessing zones within the battery limits, recycle streams from the C3 and C4 olefins recovery steps, and raffinate from a pyrolysis gasoline aromatics extraction zone within the battery limits. Feeds to the gas oil steam cracker include unconverted oil intermediates from vacuum gas oil hydrotreating.

(56)

References Cited

U.S. PATENT DOCUMENTS

2008/0194900	A1	8/2008	Bhirud	
2010/0056839	A1	3/2010	Ramachandran et al.	
2010/0087692	A1	4/2010	Yoshimura et al.	
2010/0168487	A1	7/2010	Sawyer et al.	
2010/0285950	A1	11/2010	Mao	
2011/0042269	A1	2/2011	Keuchler et al.	
2011/0119994	A1	5/2011	Hogendoorn et al.	
2011/0174682	A1	7/2011	Iaccino	
2013/0237714	A1	9/2013	Vijayakumari et al.	
2013/0245295	A1	9/2013	Westrenen	
2013/0248419	A1	9/2013	Abba et al.	
2014/0081061	A1	3/2014	Stanley et al.	
2016/0115400	A1	4/2016	Sun et al.	
2016/0137933	A1*	5/2016	Ward	C10G 69/06 208/60
2016/0368838	A1	12/2016	Ward et al.	
2016/0369180	A1*	12/2016	Ward	C10G 45/00
2016/0369188	A1	12/2016	Housmans et al.	
2017/0009155	A1	1/2017	Oprins	

FOREIGN PATENT DOCUMENTS

GB	1301019	A	12/1972	
WO	2014177424	A2	11/2014	
WO	WO-2015000841	A1*	1/2015 C10G 65/00
WO	2016071776	A2	5/2016	
WO	2017014976	A1	1/2017	

* cited by examiner

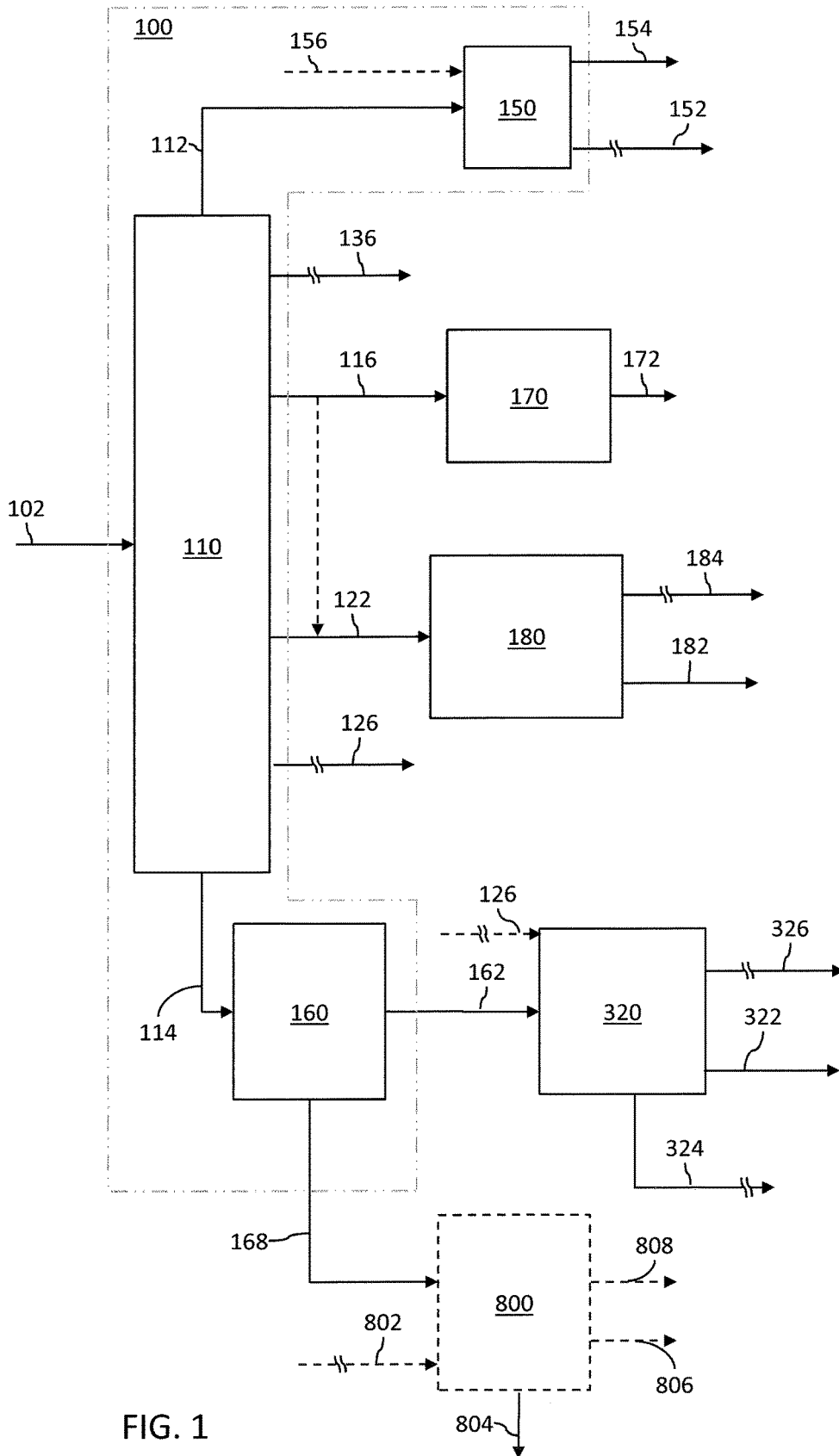

FIG. 1

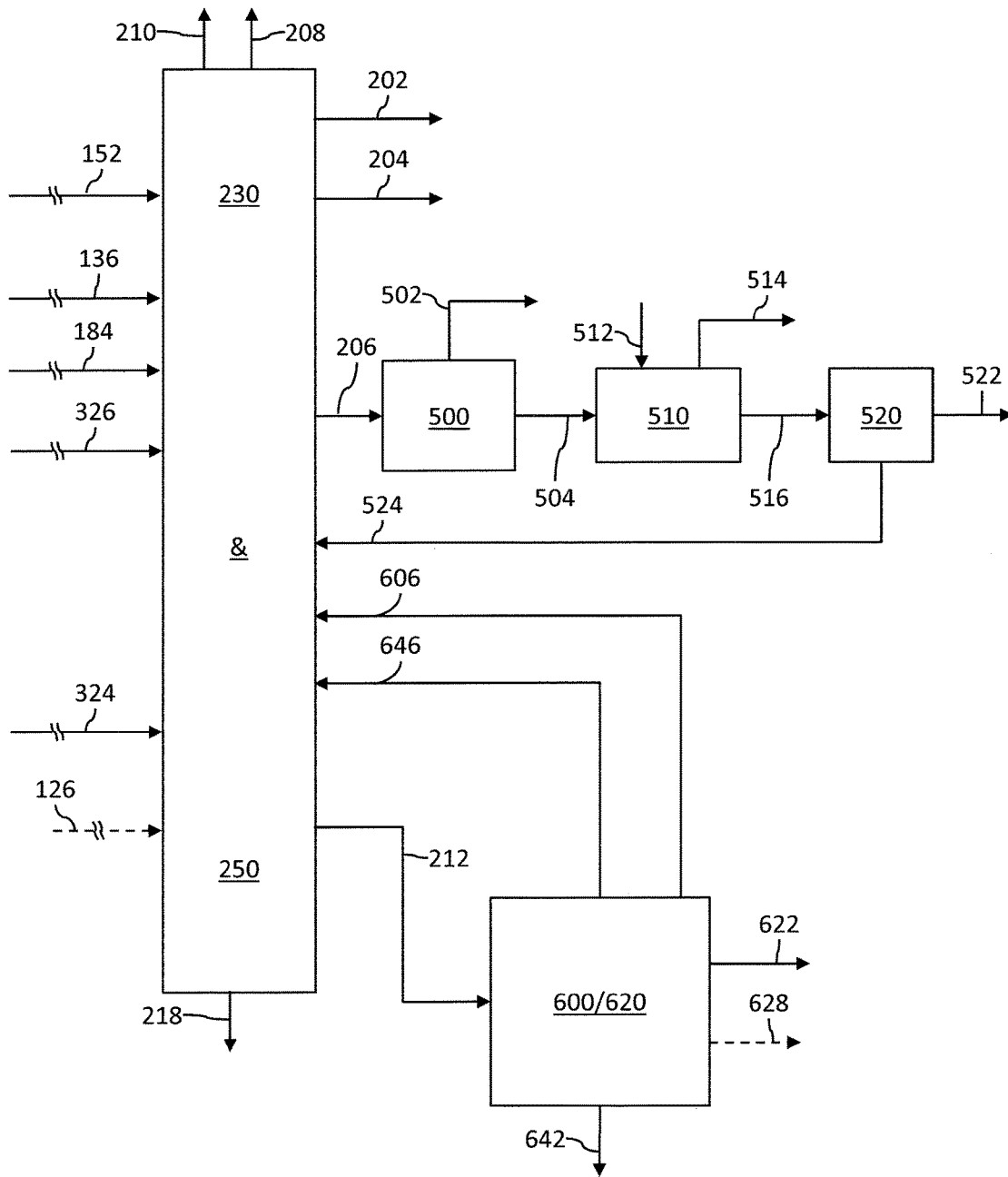

FIG. 2

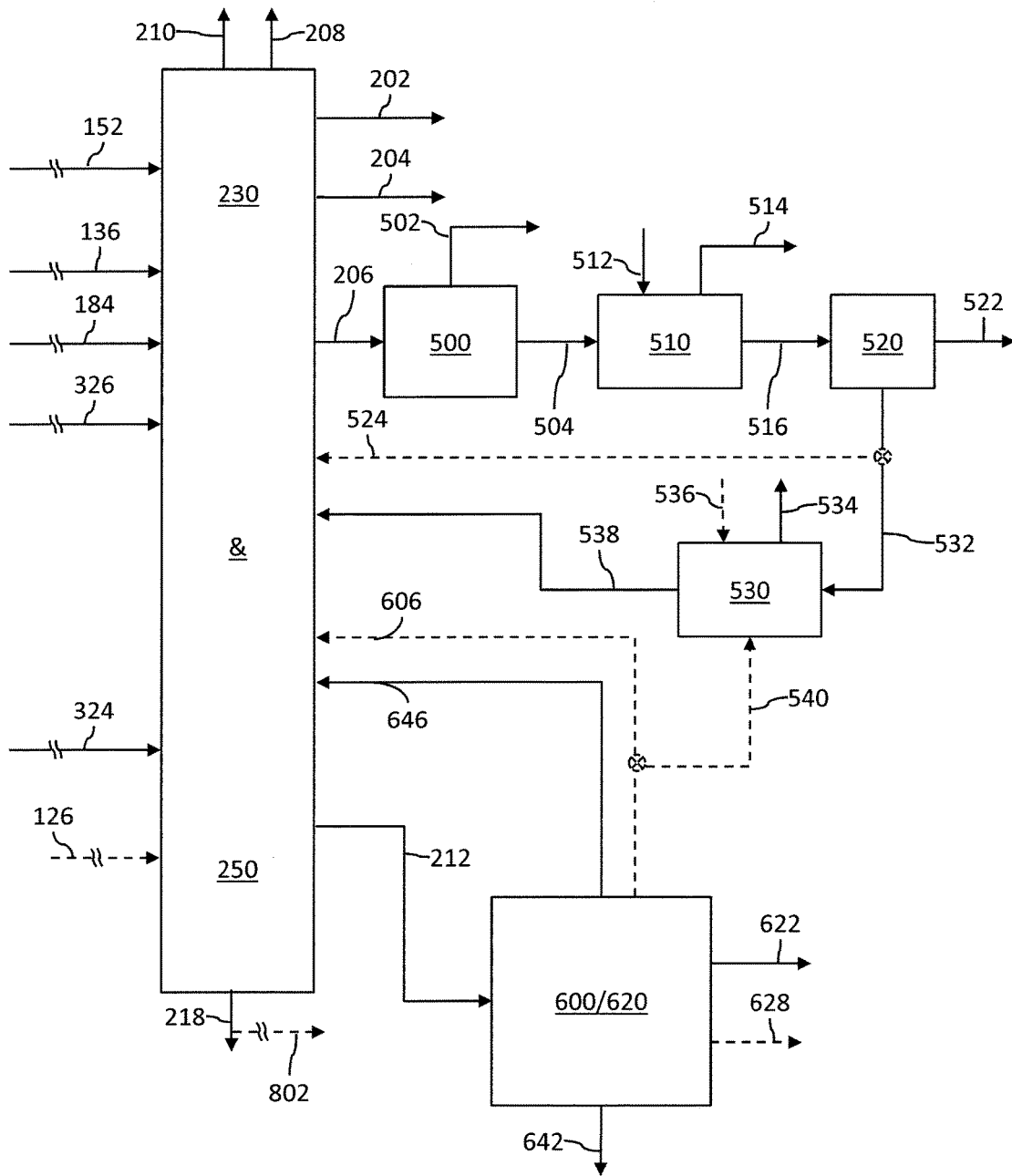

FIG. 3

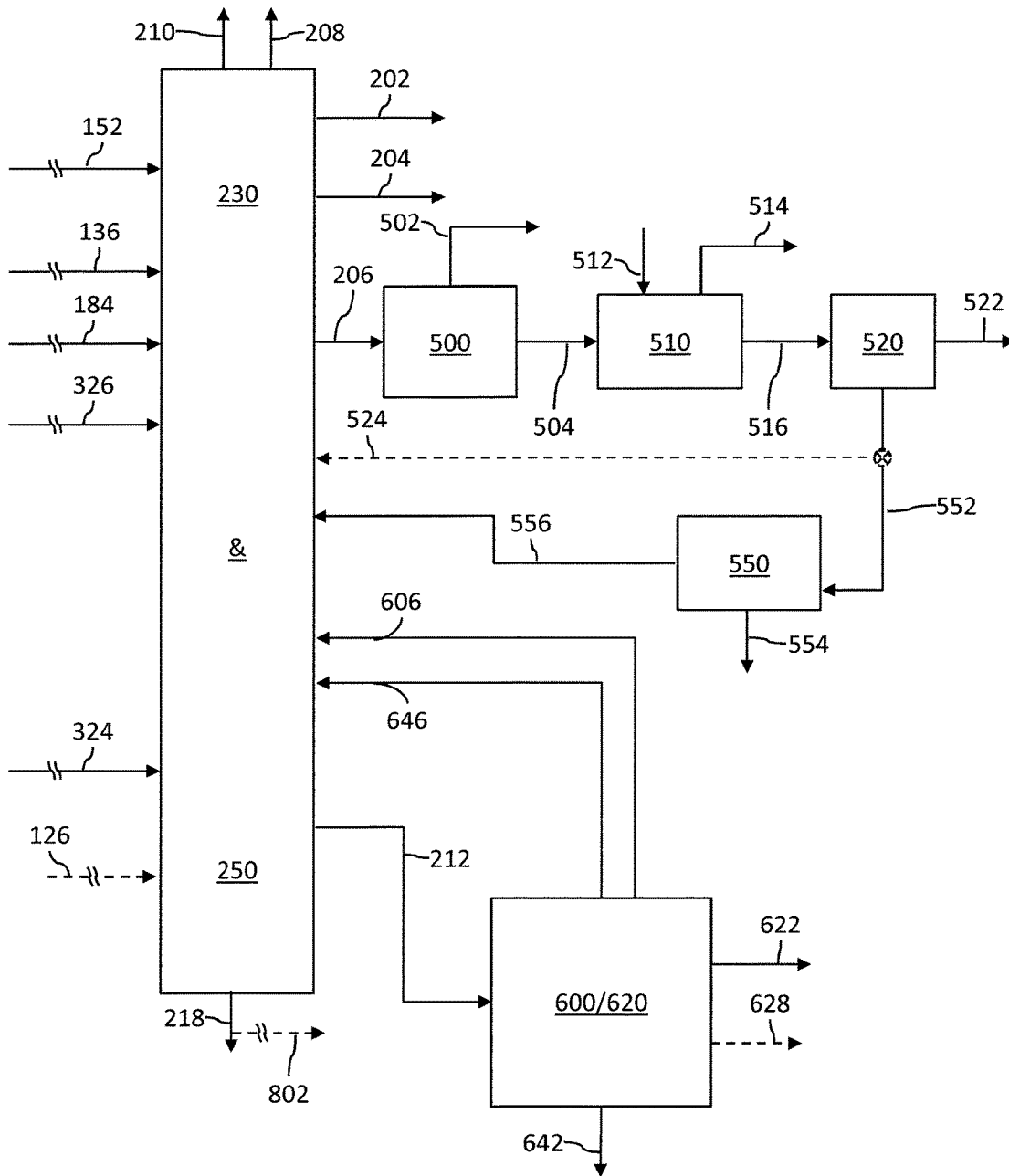

FIG. 4

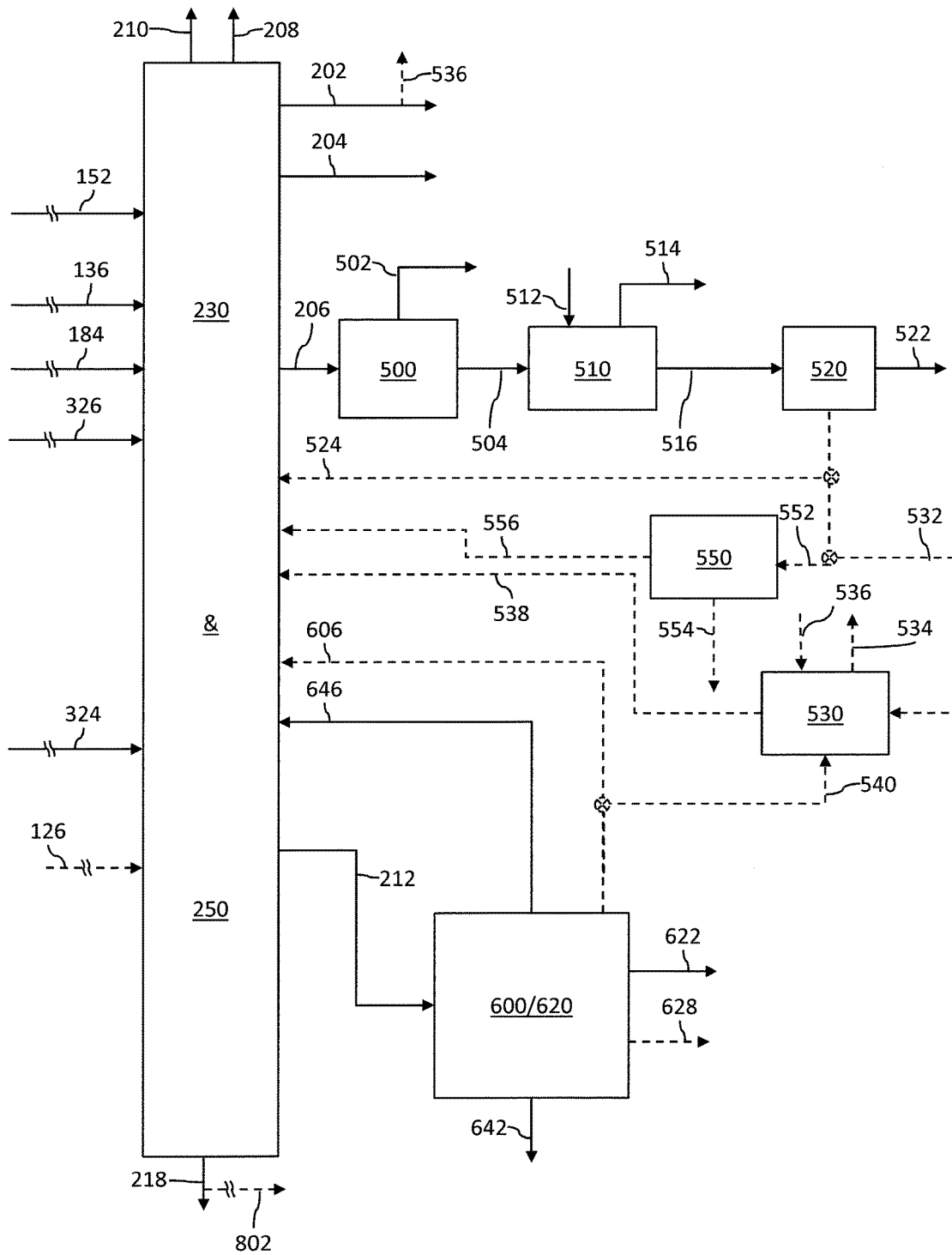

FIG. 5

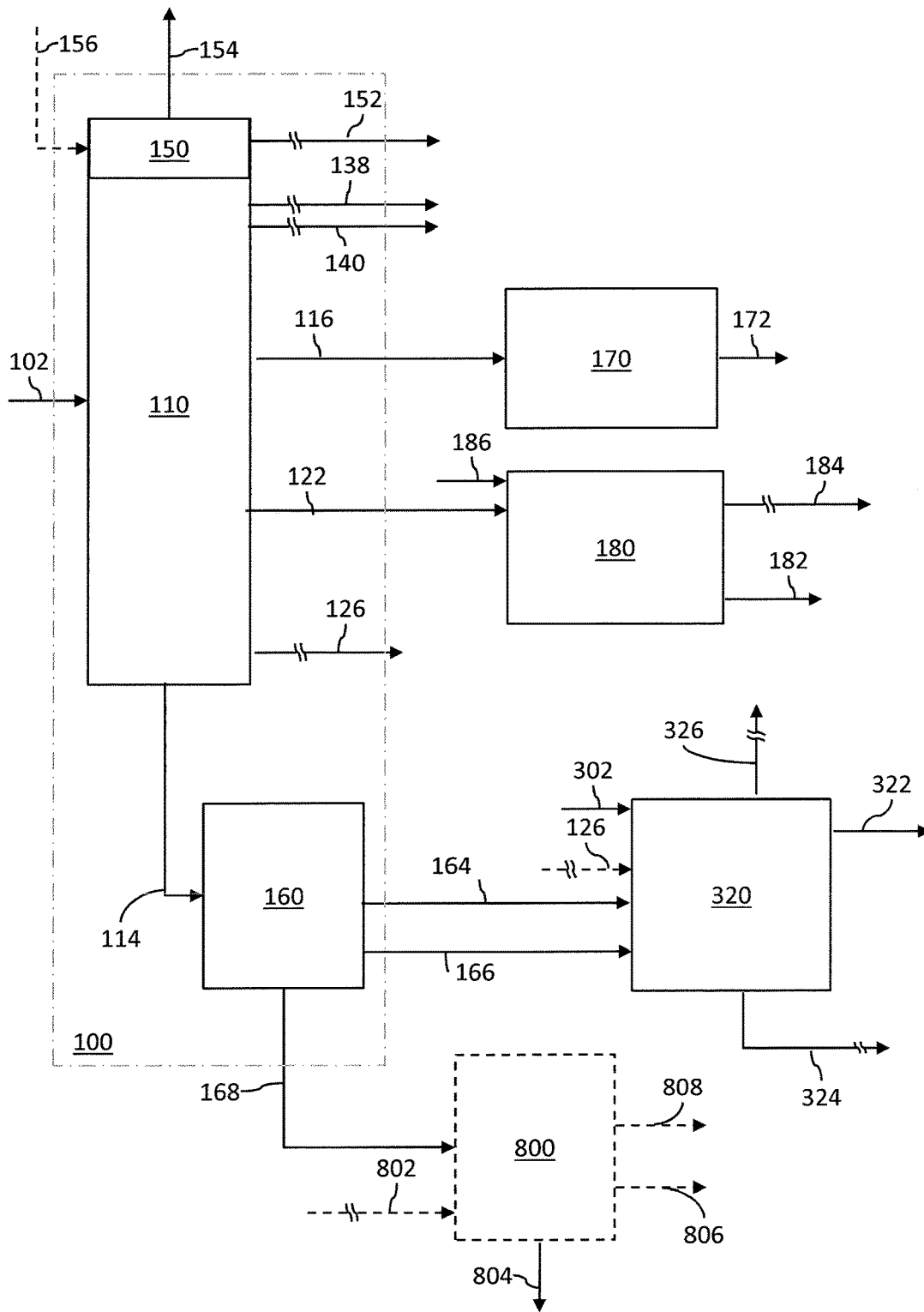

FIG. 6

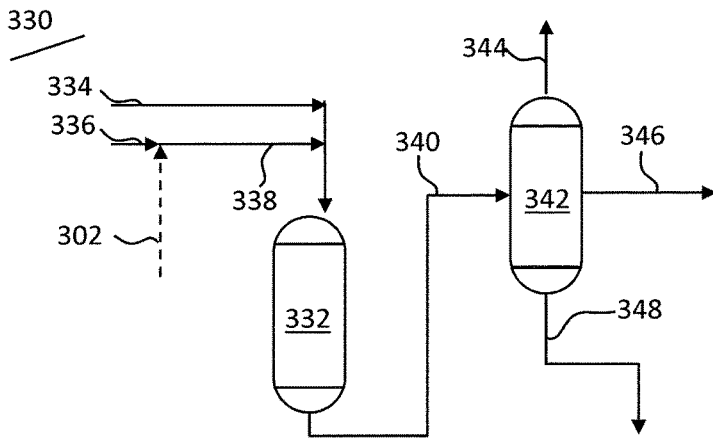

FIG. 7

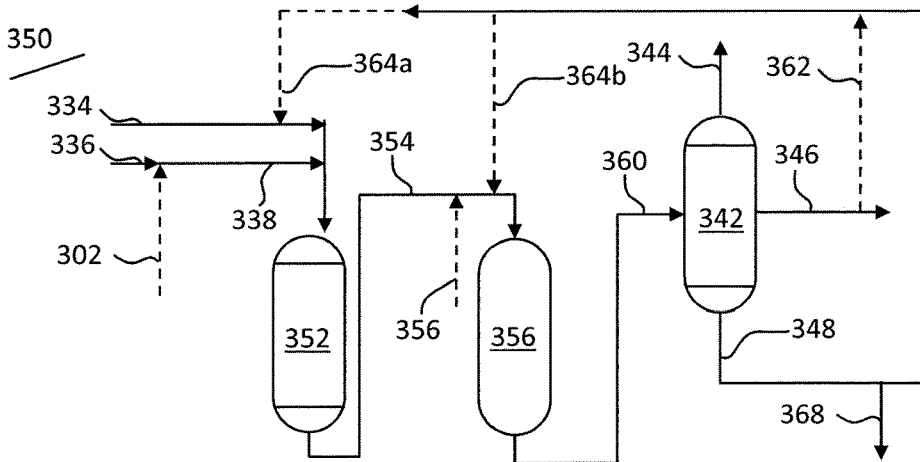

FIG. 8

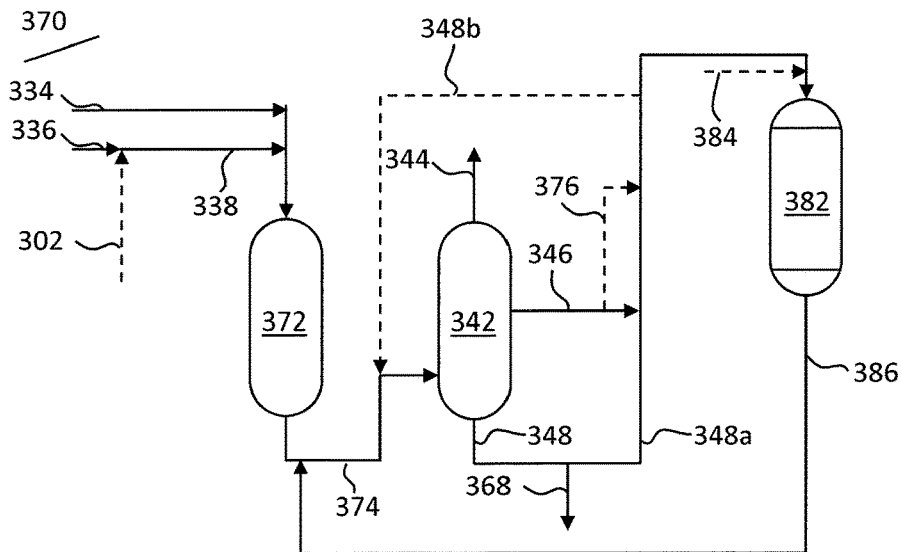

FIG. 9

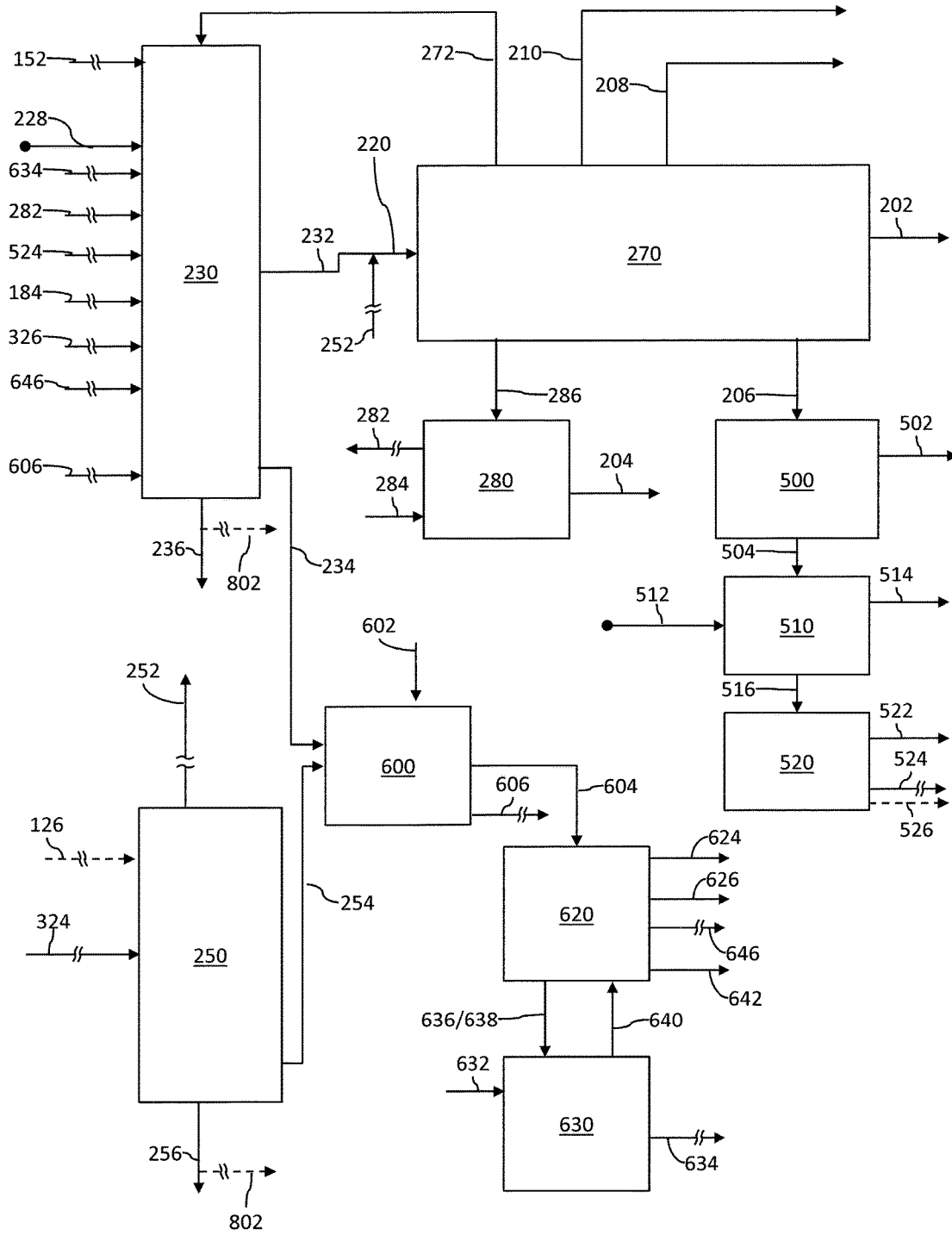

FIG. 10

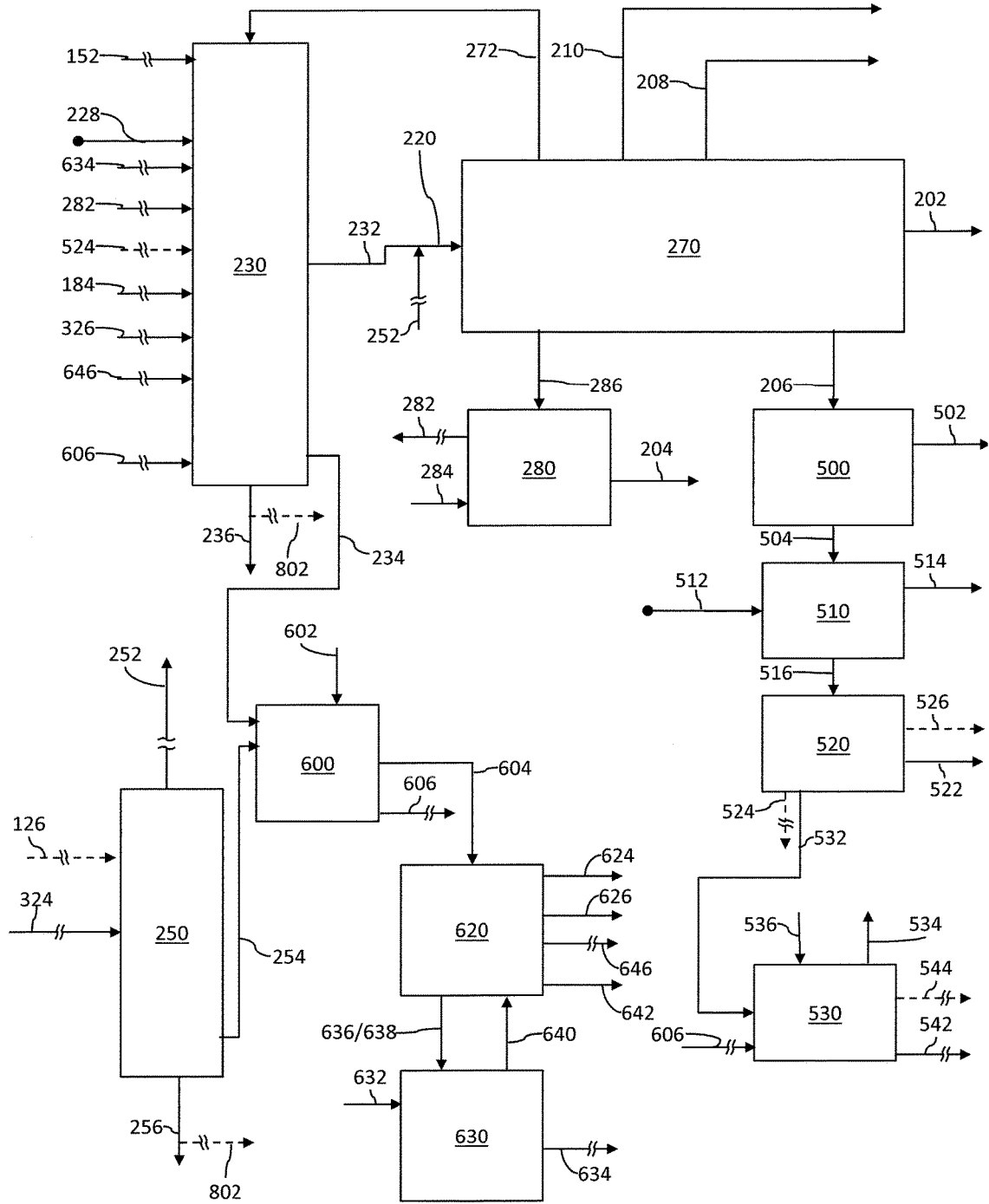

FIG. 11

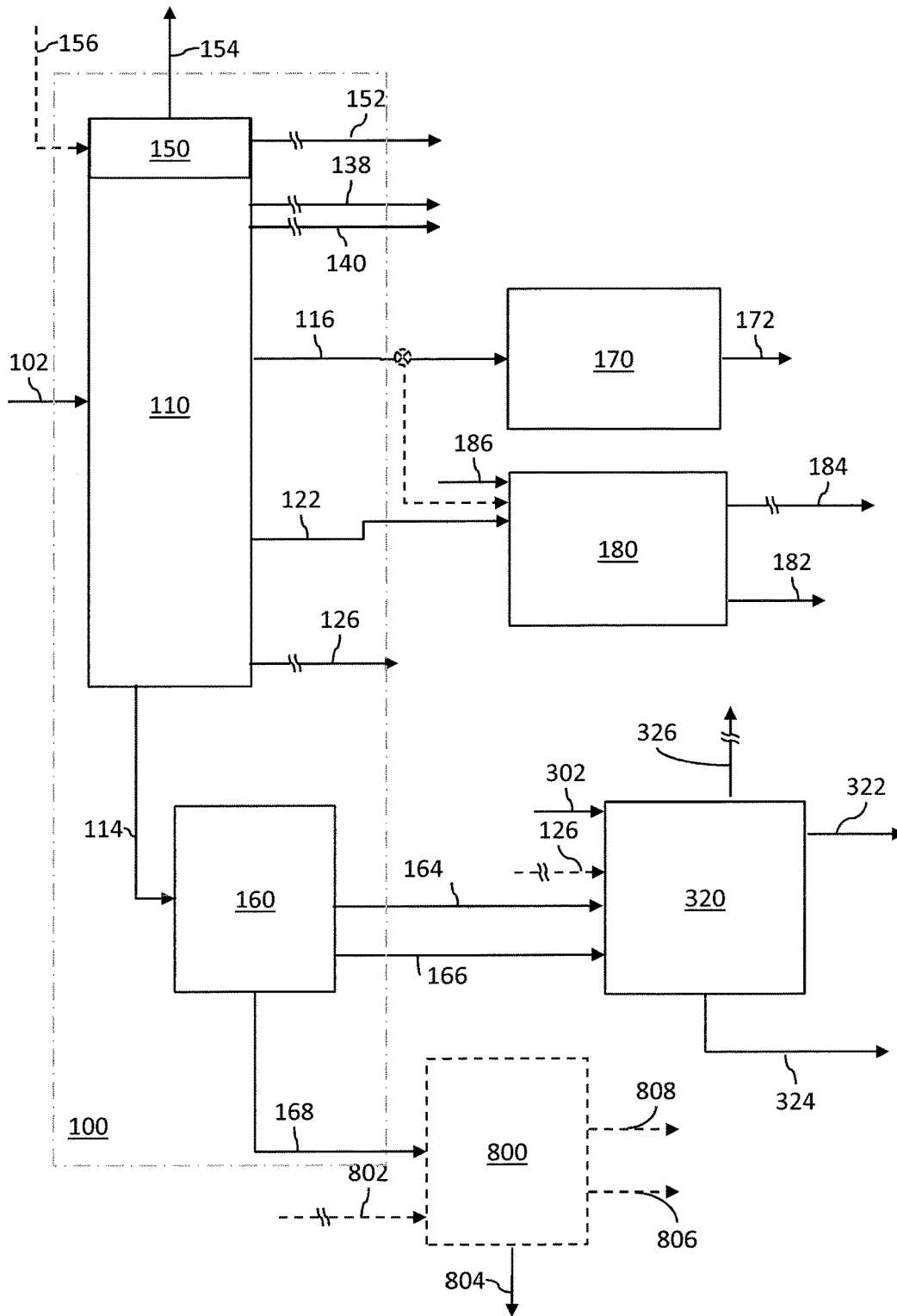

FIG. 12

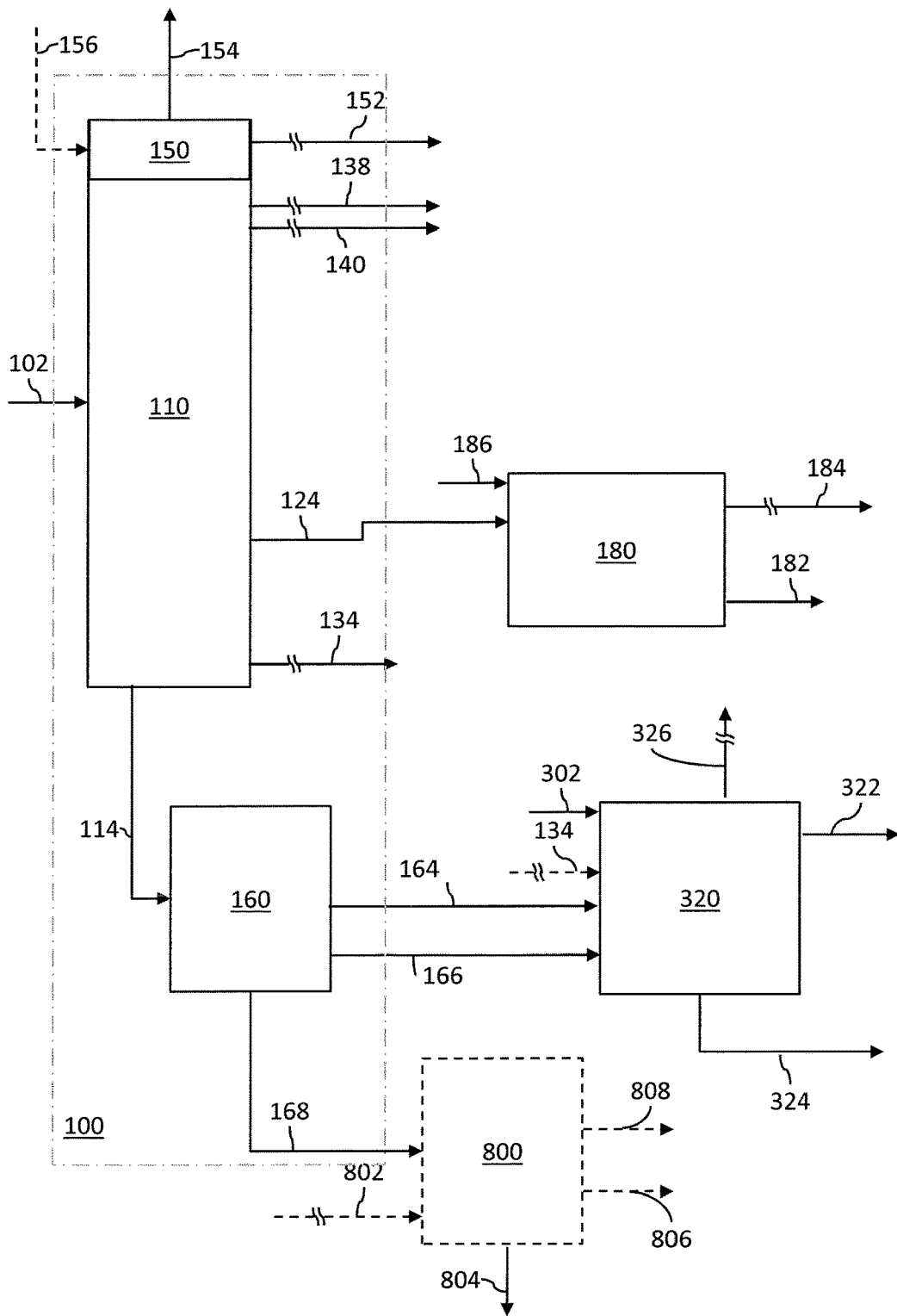

FIG. 13

**PROCESS AND SYSTEM FOR CONVERSION
OF CRUDE OIL TO PETROCHEMICALS
AND FUEL PRODUCTS INTEGRATING
VACUUM GAS OIL HYDROCRACKING AND
STEAM CRACKING**

RELATED APPLICATIONS

This application claims priority to U.S. Provisional Patent Application No. 62/424,883 filed Nov. 21, 2016, U.S. Provisional Patent Application No. 62/450,018 filed Jan. 24, 2017, U.S. Provisional Patent Application No. 62/450,031 filed Jan. 24, 2017, U.S. Provisional Patent Application No. 62/450,043 filed Jan. 24, 2017, and U.S. Provisional Patent Application No. 62/450,062 filed Jan. 24, 2017, the contents of which are all incorporated herein by reference in their entireties.

BACKGROUND OF THE INVENTION

Field of the Invention

The inventions disclosed herein relate to an integrated process and system for converting crude oil to petrochemicals and fuel products.

Description of Related Art

The lower olefins (i.e., ethylene, propylene, butylene and butadiene) and aromatics (i.e., benzene, toluene and xylene) are basic intermediates which are widely used in the petrochemical and chemical industries. Thermal cracking, or steam pyrolysis, is a major type of process for forming these materials, typically in the presence of steam, and in the absence of oxygen. Typical feedstocks for steam pyrolysis can include petroleum gases, such as ethane, and distillates such as naphtha, kerosene and gas oil. The availability of these feedstocks is usually limited and requires costly and energy-intensive process steps in a crude oil refinery.

A very significant portion of ethylene production relies on naphtha as the feedstock. However, heavy naphtha has a lower paraffin and higher aromatics content than light naphtha, making it less suitable as feedstock in the production of ethylene without upgrading. Heavy naphtha can vary in the amount of total paraffins and aromatics based on its source. Paraffins content can range between about 27-70%, naphthenes content can range between about 15-60%, and the aromatics content can range between about 10-36% (volume basis).

Many chemicals producers are limited by the supply and quality of feed from nearby refiners due to reliance on oil refinery by-products as feed. Chemicals producers are also limited by the high cost of oil refining and its associated fuels markets, which may negatively influence the economic value of refinery sourced feeds. Higher global fuel efficiency standards for automobiles and trucks will reduce fuels demand and narrow refinery margins, and may complicate the economics of fuels and chemicals supply and/or markets.

A need remains in the art for improved processes for converting crude oil to basic chemical intermediates such as lower olefins and aromatics. In addition, a need remains in the art for new approaches that offer higher value chemical production opportunities with greater leverage on economies of scale.

SUMMARY

In accordance with one or more embodiments, the invention relates to an integrated process for producing petro-

chemicals and fuel product from a crude oil feed. The integrated process includes an initial separation step to separate from a crude oil feed in an atmospheric distillation zone at least a fraction comprising straight run naphtha and lighter components, one or more middle distillate fractions, and an atmospheric residue fraction. A vacuum gas oil fraction is separated from the atmospheric residue fraction in a vacuum distillation zone. In a distillate hydroprocessing ("DHP") zone, such as a diesel hydrotreater, at least a portion of the middle distillates are processed to produce a naphtha fraction and a diesel fuel fraction. The vacuum gas oil fraction (and optionally all or a portion of an atmospheric gas oil fraction, or all or a portion of a heavy atmospheric gas oil fraction) is processed in a gas oil hydrocracking zone. Unconverted oil is processed in a gas oil steam cracking zone. The fraction(s) from the atmospheric distillation with straight run naphtha and lighter components, and an aromatics extraction zone raffinate, are processed in a mixed feed steam cracking zone. The products from the mixed feed steam cracking zone and the gas oil steam cracking zone include integrated or separate mixed product stream(s) comprising H₂, methane, ethane, ethylene, mixed C₃s and mixed C₄s; pyrolysis gasoline stream(s); and pyrolysis oil stream(s).

From the mixed product stream(s) C₃s and the mixed C₄s, petrochemicals ethylene, propylene and butylenes are recovered. Ethane and non-olefinic C₃s are recycled to the mixed feed steam cracking zone, and non-olefinic C₄s are recycled to the mixed feed steam cracking zone or to a separate processing zone for production of additional petrochemicals. Pyrolysis gasoline is treated in a py-gas hydroprocessing zone to produce hydrotreated pyrolysis gasoline. The hydrotreated pyrolysis gasoline is routed to the aromatics extraction zone to recover aromatic products and the aromatics extraction zone raffinate that is recycled to the mixed feed steam cracking zone.

Still other aspects, embodiments, and advantages of these exemplary aspects and embodiments, are discussed in detail below. Moreover, it is to be understood that both the foregoing information and the following detailed description are merely illustrative examples of various aspects and embodiments, and are intended to provide an overview or framework for understanding the nature and character of the claimed aspects and embodiments. The accompanying drawings are included to provide illustration and a further understanding of the various aspects and embodiments, and are incorporated in and constitute a part of this specification. The drawings, together with the remainder of the specification, serve to explain principles and operations of the described and claimed aspects and embodiments.

BRIEF DESCRIPTION OF THE DRAWINGS

The invention will be described in further detail below and with reference to the attached drawings in which the same or similar elements are referred to by the same number, and where:

FIG. 1 schematically depicts operations upstream of a steam cracker complex in embodiments of processes for producing petrochemicals and fuel product;

FIG. 2 schematically depicts operations downstream of and including a steam cracker complex in embodiments of processes for producing petrochemicals and fuel product;

FIG. 3 schematically depicts operations downstream of and including a steam cracker complex in embodiments of processes for producing petrochemicals integrating metathesis;

FIG. 4 schematically depicts operations downstream of and including a steam cracker complex in embodiments of processes for producing petrochemicals and fuel products integrating mixed butanol production;

FIG. 5 schematically depicts operations downstream of and including a steam cracker complex in embodiments of processes for producing petrochemicals and fuel products integrating metathesis and mixed butanol production;

FIG. 6 schematically depicts operations upstream of a steam cracker complex in further embodiments of processes for producing petrochemicals and fuel product;

FIG. 7 schematically depicts a single reactor hydrocracking zone;

FIG. 8 schematically depicts a series-flow hydrocracking zone with recycle;

FIG. 9 schematically depicts a two-stage hydrocracking zone with recycle;

FIG. 10 schematically depicts operations downstream of and including a steam cracker complex in further embodiments of processes for producing petrochemicals and fuel product;

FIG. 11 schematically depicts operations in further embodiments of processes for producing petrochemicals and fuel products integrating metathesis; and

FIGS. 12 and 13 schematically depict operations upstream of a steam cracker complex in still further embodiments of processes for producing petrochemicals and fuel product.

DESCRIPTION

Process scheme configurations are disclosed that enable conversion of crude oil feeds with several processing units in an integrated manner into petrochemicals. The designs utilize minimum capital expenditures to prepare suitable feedstocks for the steam cracker complex. The integrated process for converting crude oil to petrochemical products including olefins and aromatics, and fuel products, includes mixed feed steam cracking and gas oil steam cracking. Feeds to the mixed feed steam cracker include light products and naphtha from hydroprocessing zones within the battery limits, recycle streams from the C3 and C4 olefins recovery steps, and raffinate from a pyrolysis gasoline aromatics extraction zone within the battery limits. Feeds to the gas oil steam cracker include unconverted oil intermediates from vacuum gas oil hydrotreating.

The phrase "a major portion" with respect to a particular stream or plural streams means at least about 50 wt % and up to 100 wt %, or the same values of another specified unit.

The phrase "a significant portion" with respect to a particular stream or plural streams means at least about 75 wt % and up to 100 wt %, or the same values of another specified unit.

The phrase "a substantial portion" with respect to a particular stream or plural streams means at least about 90, 95, 98 or 99 wt % and up to 100 wt %, or the same values of another specified unit.

The phrase "a minor portion" with respect to a particular stream or plural streams means from about 1, 2, 4 or 10 wt %, up to about 20, 30, 40 or 50 wt %, or the same values of another specified unit.

The term "crude oil" as used herein refers to petroleum extracted from geologic formations in its unrefined form. Crude oil suitable as the source material for the processes herein include Arabian Heavy, Arabian Light, Arabian Extra Light, other Gulf crudes, Brent, North Sea crudes, North and West African crudes, Indonesian, Chinese crudes, or mix-

tures thereof. The crude petroleum mixtures can be whole range crude oil or topped crude oil. As used herein, "crude oil" also refers to such mixtures that have undergone some pre-treatment such as water-oil separation; and/or gas-oil separation; and/or desalting; and/or stabilization. In certain embodiments, crude oil refers to any of such mixtures having an API gravity (ASTM D287 standard), of greater than or equal to about 20°, 30°, 32°, 34°, 36°, 38°, 40°, 42° or 44°.

The acronym "AXL" as used herein refers to Arab Extra Light crude oil, characterized by an API gravity of greater than or equal to about 38°, 40°, 42° or 44°, and in certain embodiments in the range of about 38°-46°, 38°-44°, 38°-42°, 38°-40.5°, 39°-46°, 39°-44°, 39°-42° or 39°-40.5°.

The acronym "AL" as used herein refers to Arab Light crude oil, characterized by an API gravity of greater than or equal to about 30°, 32°, 34°, 36° or 38°, and in certain embodiments in the range of about 30°-38°, 30°-36°, 30°-35°, 32°-38°, 32°-36°, 32°-35°, 33°-38°, 33°-36° or 33°-35°.

The acronym "LPG" as used herein refers to the well-known acronym for the term "liquefied petroleum gas," and generally is a mixture of C3-C4 hydrocarbons. In certain embodiments, these are also referred to as "light ends."

The term "naphtha" as used herein refers to hydrocarbons boiling in the range of about 20-205, 20-193, 20-190, 20-180, 20-170, 32-205, 32-193, 32-190, 32-180, 32-170, 36-205, 36-193, 36-190, 36-180 or 36-170° C.

The term "light naphtha" as used herein refers to hydrocarbons boiling in the range of about 20-110, 20-100, 20-90, 20-88, 32-110, 32-100, 32-90, 32-88, 36-110, 36-100, 36-90 or 36-88° C.

The term "heavy naphtha" as used herein refers to hydrocarbons boiling in the range of about 90-205, 90-193, 90-190, 90-180, 90-170, 93-205, 93-193, 93-190, 93-180, 93-170, 100-205, 100-193, 100-190, 100-180, 100-170, 110-205, 110-193, 110-190, 110-180 or 110-170° C.

In certain embodiments naphtha, light naphtha and/or heavy naphtha refer to such petroleum fractions obtained by crude oil distillation, or distillation of intermediate refinery processes as described herein.

The modifying term "straight run" is used herein having its well-known meaning, that is, describing fractions derived directly from the atmospheric distillation unit, optionally subjected to steam stripping, without other refinery treatment such as hydroprocessing, fluid catalytic cracking or steam cracking. An example of this is "straight run naphtha" and its acronym "SRN" which accordingly refers to "naphtha" defined above that is derived directly from the atmospheric distillation unit, optionally subjected to steam stripping, as is well known.

The term "kerosene" as used herein refers to hydrocarbons boiling in the range of about 170-280, 170-270, 170-260, 180-280, 180-270, 180-260, 190-280, 190-270, 190-260, 193-280, 193-270 or 193-260° C.

The term "light kerosene" as used herein refers to hydrocarbons boiling in the range of about 170-250, 170-235, 170-230, 170-225, 180-250, 180-235, 180-230, 180-225, 190-250, 190-235, 190-230 or 190-225° C.

The term "heavy kerosene" as used herein refers to hydrocarbons boiling in the range of about 225-280, 225-270, 225-260, 230-280, 230-270, 230-260, 235-280, 235-270, 235-260 or 250-280° C.

The term "atmospheric gas oil" and its acronym "AGO" as used herein refer to hydrocarbons boiling in the range of about 250-370, 250-360, 250-340, 250-320, 260-370, 260-360, 260-340, 260-320, 270-370, 270-360, 270-340 or 270-320° C.

The term "heavy atmospheric gas oil" and its acronym "H-AGO" as used herein in certain embodiments refer to the heaviest cut of hydrocarbons in the AGO boiling range including the upper 3-30° C. range (e.g., for AGO having a range of about 250-360° C., the range of H-AGO includes an initial boiling point from about 330-357° C. and an end boiling point of about 360° C.).

The term "medium atmospheric gas oil" and its acronym "M-AGO" as used herein in certain embodiments in conjunction with H-AGO to refer to the remaining AGO after H-AGO is removed, that is, hydrocarbons in the AGO boiling range excluding the upper about 3-30° C. range (e.g., for AGO having a range of about 250-360° C., the range of M-AGO includes an initial boiling point of about 250° C. and an end boiling point of from about 330-357° C.).

In certain embodiments, the term "diesel" is used with reference to a straight run fraction from the atmospheric distillation unit. In embodiments in which this terminology is used, the diesel fraction refers to medium AGO range hydrocarbons and in certain embodiments also in combination with heavy kerosene range hydrocarbons.

The term "atmospheric residue" and its acronym "AR" as used herein refer to the bottom hydrocarbons having an initial boiling point corresponding to the end point of the AGO range hydrocarbons, and having an end point based on the characteristics of the crude oil feed.

The term "vacuum gas oil" and its acronym "VGO" as used herein refer to hydrocarbons boiling in the range of about 370-550, 370-540, 370-530, 370-510, 400-550, 400-540, 400-530, 400-510, 420-550, 420-540, 420-530 or 420-510° C.

The term "light vacuum gas oil" and its acronym "LVGO" as used herein refer to hydrocarbons boiling in the range of about 370-425, 370-415, 370-405, 370-395, 380-425, 390-425 or 400-425° C.

The term "heavy vacuum gas oil" and its acronym "HVGO" as used herein refer to hydrocarbons boiling in the range of about 425-550, 425-540, 425-530, 425-510, 450-550, 450-540, 450-530 or 450-510° C.

The term "vacuum residue" and its acronym "VR" as used herein refer to the bottom hydrocarbons having an initial boiling point corresponding to the end point of the VGO range hydrocarbons, and having an end point based on the characteristics of the crude oil feed.

The term "fuels" refers to crude oil-derived products used as energy carriers. Fuels commonly produced by oil refineries include, but are not limited to, gasoline, jet fuel, diesel fuel, fuel oil and petroleum coke. Unlike petrochemicals, which are a collection of well-defined compounds, fuels typically are complex mixtures of different hydrocarbon compounds.

The terms "kerosene fuel" or "kerosene fuel products" refer to fuel products used as energy carriers, such as jet fuel or other kerosene range fuel products (and precursors for producing such jet fuel or other kerosene range fuel products). Kerosene fuel includes but is not limited to kerosene fuel products meeting Jet A or Jet A-1 jet fuel specifications.

The terms "diesel fuel" and "diesel fuel products" refer to fuel products used as energy carriers suitable for compression-ignition engines (and precursors for producing such fuel products). Diesel fuel includes but is not limited to ultra-low sulfur diesel compliant with Euro V diesel standards.

The term "aromatic hydrocarbons" or "aromatics" is very well known in the art. Accordingly, the term "aromatic hydrocarbon" relates to cyclically conjugated hydrocarbons with a stability (due to delocalization) that is significantly

greater than that of a hypothetical localized structure (e.g., Kekule structure). The most common method for determining aromaticity of a given hydrocarbon is the observation of diatropicity in its ¹H NMR spectrum, for example the presence of chemical shifts in the range of from 7.2 to 7.3 ppm for benzene ring protons.

The terms "naphthenic hydrocarbons" or "naphthenes" or "cycloalkanes" are used herein having their established meanings and accordingly relates to types of alkanes that have one or more rings of carbon atoms in the chemical structure of their molecules.

The term "wild naphtha" is used herein to refer to naphtha products derived from hydroprocessing units such as distillate hydroprocessing units, diesel hydroprocessing units and/or gas oil hydroprocessing units.

The term "unconverted oil" and its acronym "UCO," is used herein having its known meaning, and refers to a highly paraffinic fraction from a hydrocracker with a low nitrogen, sulfur and nickel content and including hydrocarbons having an initial boiling point corresponding to the end point of the AGO range hydrocarbons, in certain embodiments the initial boiling point in the range of about 340-370° C., for instance about 340, 360 or 370° C., and an end point in the range of about 510-560° C., for instance about 540, 550 or 560° C. UCO is also known in the industry by other synonyms including "hydrowax."

The term "C# hydrocarbons" or "C#", is used herein having its well-known meaning, that is, wherein "#" is an integer value, and means hydrocarbons having that value of carbon atoms. The term "C#+ hydrocarbons" or "C#+" refers to hydrocarbons having that value or more carbon atoms. The term "C#- hydrocarbons" or "C#-" refers to hydrocarbons having that value or less carbon atoms. Similarly, ranges are also set forth, for instance, C1-C3 means a mixture comprising C1, C2 and C3.

The term "petrochemicals" or "petrochemical products" refers to chemical products derived from crude oil that are not used as fuels. Petrochemical products include olefins and aromatics that are used as a basic feedstock for producing chemicals and polymers. Typical olefinic petrochemical products include, but are not limited to, ethylene, propylene, butadiene, butylene-1, isobutylene, isoprene, cyclopentadiene and styrene. Typical aromatic petrochemical products include, but are not limited to, benzene, toluene, xylene, and ethyl benzene.

The term "olefin" is used herein having its well-known meaning, that is, unsaturated hydrocarbons containing at least one carbon-carbon double bond. In plural, the term "olefins" means a mixture comprising two or more unsaturated hydrocarbons containing at least one carbon-carbon double bond. In certain embodiments, the term "olefins" relates to a mixture comprising two or more of ethylene, propylene, butadiene, butylene-1, isobutylene, isoprene and cyclopentadiene.

The term "BTX" as used herein refers to the well-known acronym for benzene, toluene and xylenes.

The term "make-up hydrogen" is used herein with reference to hydroprocessing zones to refer to hydrogen requirements of the zone that exceed recycle from conventionally integrated separation vessels; in certain embodiments as used herein all or a portion of the make-up hydrogen in any given hydroprocessing zone or reactor within a zone is from gases derived from the steam cracking zone(s) in the integrated processes and systems.

The term "crude to chemicals conversion" as used herein refers to conversion of crude oil into petrochemicals including but not limited to lower olefins such as ethylene,

propylene, butylenes (including isobutylene), butadiene, MTBE, butanols, benzene, ethylbenzene, toluene, xylenes, and derivatives of the foregoing.

The term "crude to chemicals conversion ratio" as used herein refers to the ratio, on a mass basis, of the influent crude oil before desalting, to petrochemicals.

The term "crude C4" refers to the mixed C4 effluent from a steam cracking zone.

The term "C4 Raffinate 1" or "C4 Raff-1" refers to the mixed C4s stream leaving the butadiene extraction unit, that is, mixed C4s from the crude C4 except butadiene.

The term "C4 Raffinate 2" or "C4 Raff-2" refers to the mixed C4s stream leaving the MTBE unit, that is, mixed C4s from the crude C4 except butadiene and isobutene.

The term "C4 Raffinate 3" or "C4 Raff-3" refers to the mixed C4s stream leaving the C4 distillation unit, that is, mixed C4s from the crude C4 except butadiene, isobutene, and butane-1.

The terms "pyrolysis gasoline" and its abbreviated form "py-gas" are used herein having their well-known meaning, that is, thermal cracking products in the range of C5 to C9, for instance having an end boiling point of about 204.4° C. (400° F.), in certain embodiments up to about 148.9° C. (300° F.).

The terms "pyrolysis oil" and its abbreviated form "py-oil" are used herein having their well-known meaning, that is, a heavy oil fraction, C10+, that is derived from steam cracking.

The terms "light pyrolysis oil" and its acronym "LPO" as used herein in certain embodiments refer to pyrolysis oil having an end boiling point of about 440, 450, 460 or 470° C.

The terms "heavy pyrolysis oil" and its acronym "HPO" as used herein in certain embodiments refer to pyrolysis oil having an initial boiling point of about 440, 450, 460 or 470° C.

In general, the integrated process for producing petrochemicals and fuel products from a crude oil feed includes an initial separation step to separate from a crude oil feed in an atmospheric distillation zone at least a first atmospheric distillation zone fraction comprising straight run naphtha; a second atmospheric distillation zone fraction comprising at least a portion of middle distillates, and a third atmospheric distillation zone fraction comprising atmospheric residue. A first vacuum distillation zone fraction comprising vacuum gas oil is separated from the third atmospheric distillation zone fraction in a vacuum distillation zone. In a distillate hydroprocessing ("DHP") zone, such as a diesel hydrotreater, at least a portion of the second atmospheric distillation zone fraction is processed to produce at least a first DHP fraction and a second DHP fraction, wherein the first DHP fraction comprises naphtha and the second DHP fraction is used for diesel fuel production. The first vacuum distillation zone fraction (and optionally all or a portion of an atmospheric gas oil fraction, or all or a portion of a heavy atmospheric gas oil fraction) is processed in a gas oil hydrocracking zone to produce naphtha, middle distillates, and unconverted oil. Unconverted oil is processed in a gas oil steam cracking zone.

At least the first atmospheric distillation zone fraction and a pyrolysis gasoline raffinate from an aromatics extraction zone are processed in a mixed feed steam cracking zone. The products from the mixed feed steam cracking zone and the gas oil steam cracking zone include integrated or separate mixed product stream(s) comprising H₂, methane, ethane, ethylene, mixed C3s and mixed C4s; pyrolysis gasoline stream(s); and pyrolysis oil stream(s).

From the mixed product stream(s) C3s and the mixed C4s, petrochemicals ethylene, propylene and butylenes are recovered. Ethane and non-olefinic C3s are recycled to the mixed feed steam cracking zone, and non-olefinic C4s are recycled to the mixed feed steam cracking zone or to a separate processing zone for production of additional petrochemicals. Pyrolysis gasoline is treated in a py-gas hydroprocessing zone to produce hydrotreated pyrolysis gasoline. The hydrotreated pyrolysis gasoline is routed to the aromatics extraction zone to recover aromatic products and the aromatics extraction zone raffinate that is recycled to the mixed feed steam cracking zone.

Ethane and non-olefinic C3s and C4s are recovered, with ethane and non-olefinic C3s recycled to the steam cracking complex, and non-olefinic C4s recycled to the steam cracking complex or passed to a separate processing zone for production of additional petrochemicals such as propylene and/or mixed butanol liquids. Pyrolysis gasoline is treated in a py-gas hydroprocessing zone to produce hydrotreated pyrolysis gasoline, which is routed to an aromatics extraction complex to recover aromatic petrochemicals and a raffinate, including pyrolysis gasoline raffinate that is recycled to the steam cracking complex.

FIGS. 1 and 2 schematically depict embodiments of processes and systems for conversion of crude oil to petrochemicals and fuel products, including a mixed feed steam cracking zone and a gas oil steam cracking zone. Generally, FIG. 1 shows operations upstream of the mixed feed steam cracking zone ("MFSC") **230** and the gas oil steam cracking zone **250** while FIG. 2 shows operations downstream of the crude oil conversion zone and including the mixed feed steam cracking zone **230** and the gas oil steam cracking zone **250**.

The mixed feed steam cracking zone and the gas oil steam cracking zone are shown for simplicity in a single schematic block **230/250** in FIGS. 2, 3, 4 and 5.

In the description herein, both the mixed feed steam cracking zone **230** and the gas oil steam cracking zone **250** are collectively referred to as the "steam cracker complex" **230/250** in certain instances, although a person having ordinary skill in the art will appreciate that the different steam cracking zones contain different furnaces and associated exchangers, with certain products from each combined for further downstream operations. In certain embodiments quench systems and fractionation units can be combined. In additional embodiments separate quench systems and fractionation units can be used for each of the mixed feed steam cracking zone **230** and the gas oil steam cracking zone **250**.

With reference to FIG. 1, a crude oil feed **102**, in certain embodiments AXL or AL, is separated into fractions in a crude complex **100**, typically including an atmospheric distillation zone ("ADU") **110**, a saturated gas plant **150** and a vacuum distillation zone ("VDU") **160**. The crude oil feed **102**, in certain embodiments having LPG and light naphtha removed, is separated into fractions in the atmospheric distillation zone **110**. As shown in FIG. 1, light products, for instance, light hydrocarbons with fewer than six carbons, are passed to a mixed feed steam cracking zone **230**. In particular, C2-C4 hydrocarbons **152** including ethane, propane and butanes are separated from the light ends and LPG **112** from the atmospheric distillation zone **110** via the saturated gas plant **150**. Optionally, other light products are routed to the saturated gas plant **150**, shown in dashed lines as stream **156**, such as light gases from refinery units within the integrated system, and in certain embodiments light gases from outside of the battery limits. The separated C2-C4 hydrocarbons **152** are routed to the mixed feed steam

cracking zone **230**. Off-gases **154** from the saturated gas plant **150** and off-gases **208** from the mixed feed steam cracking zone **230** and gas oil steam cracking zone **250** are removed and recovered as is typically known, for instance to contribute to a fuel gas ("FG") system.

Straight run naphtha **136** from the atmospheric distillation zone **110** is passed to the mixed feed steam cracking zone **230**. In certain embodiments, all, a substantial portion or a significant portion of the straight run naphtha **136** is routed to the mixed feed steam cracking zone **230**. Remaining naphtha (if any) can be added to a gasoline pool. In addition, in certain embodiments the straight run naphtha stream **136** contains naphtha from other sources as described herein and sometimes referred to as wild naphtha, for instance, naphtha range hydrocarbons from one or more of the integrated distillate, gas oil and/or residue hydroprocessing units.

Middle distillates are used to produce diesel and/or kerosene, and additional feed to the mixed feed steam cracking zone **230**. In the embodiments shown in FIG. 1, at least three different middle distillate cuts are processed for production of fuel products and petrochemicals (via the steam cracker). In one example using the arrangement shown in FIG. 1, a first atmospheric distillation zone middle distillate fraction **116**, in certain embodiments referred to as a kerosene fraction, contains light kerosene range hydrocarbons, a second atmospheric distillation zone middle distillate fraction **122**, in certain embodiments referred to as a diesel fraction, contains heavy kerosene range hydrocarbons and medium AGO range hydrocarbons, and a third atmospheric distillation zone middle distillate fraction **126**, in certain embodiments referred to as an atmospheric gas oil fraction, contains heavy AGO range hydrocarbons. In another example using the arrangement shown in FIG. 1, a first middle distillate fraction **116** contains kerosene range hydrocarbons, a second middle distillate fraction **122** contains medium AGO range hydrocarbons and a third middle distillate fraction **126** contains heavy AGO range hydrocarbons. In another example using the arrangement shown in FIG. 1, a first middle distillate fraction **116** contains light kerosene range hydrocarbons and a portion of heavy kerosene range hydrocarbons, a second middle distillate fraction **122** contains a portion of heavy kerosene range hydrocarbons and a portion of medium AGO range hydrocarbons and a third middle distillate fraction **126** contains a portion of medium AGO range hydrocarbons and heavy AGO range hydrocarbons.

For example, a first middle distillate fraction **116** can be processed in a kerosene sweetening process **170** to produce kerosene fuel product **172**, for instance, jet fuel compliant with Jet A or Jet A-1 specifications, and optionally other fuel products (not shown). In certain embodiments herein, all or a portion of the first middle distillate fraction **116** is not used for fuel production, but rather is used as a feed for distillate hydroprocessing so as to produce additional feed for the mixed feed steam cracking zone **230**.

A second middle distillate fraction **122** is processed in a distillate hydroprocessing zone such as a diesel hydrotreating zone **180**, to produce wild naphtha **184** and a diesel fuel fraction **182**, for instance, compliant with Euro V diesel standards. In additional embodiments, all or a portion of the first middle distillate fraction **116** can be treated with the second middle distillate fraction **122**, as denoted by dashed lines.

All or a portion of the wild naphtha **184** is routed to the mixed feed steam cracking zone **230**; any portion that is not passed to the mixed feed steam cracking zone **230** can be routed to the gasoline pool. In certain embodiments, the wild

naphtha **184** is routed through the crude complex **100**, alone, or in combination with other wild naphtha fractions from within the integrated process. In embodiments in which the wild naphtha **184** is routed through the crude complex **100**, all or a portion of the liquefied petroleum gas produced in the vacuum gas oil hydroprocessing zone can be passed with the wild naphtha. In certain embodiments, all, a substantial portion, a significant portion or a major portion of the wild naphtha **184** is routed to the mixed feed steam cracking zone **230** (directly or through the crude complex **100**).

In certain embodiments (as denoted by dashed lines), all, a substantial portion, a significant portion or a major portion of the third middle distillate fraction **126** is routed to the vacuum gas oil hydroprocessing zone in combination with the vacuum gas oil stream **162**; any portion that is not passed to the vacuum gas oil hydroprocessing zone can be routed to the gas oil steam cracking zone **250** without hydroprocessing. In further embodiments (as denoted by dashed lines), all, a substantial portion, a significant portion or a major portion of the third middle distillate fraction **126** is routed to the gas oil steam cracking zone **250** without hydroprocessing, and any portion that is not passed to the gas oil steam cracking zone **250** is routed to the vacuum gas oil hydroprocessing zone.

An atmospheric residue fraction **114** from the atmospheric distillation zone **110** is further separated in the vacuum distillation zone **160**. Vacuum gas oil **162** from the vacuum distillation zone **160** is routed to the vacuum gas oil hydrocracking zone **320**. In certain embodiments, vacuum gas oil **162** can bypass the vacuum gas oil hydrocracking zone **320** and be routed to the gas oil steam cracking zone **250** (not shown). The heaviest fraction **168** from the vacuum distillation zone **160**, vacuum residue, can be sent to a fuel oil ("FO") pool and/or optionally processed in a residue treatment zone **800**, shown in dashed lines. In certain embodiments, a minor portion of the atmospheric residue fraction **114** can bypass the vacuum distillation zone **160** (not shown) and is routed to the optional residue treating zone **800** and/or the gas oil steam cracking zone **250** (not shown).

The vacuum gas oil hydrocracking zone **320** can operate under mild, moderate or severe hydrocracking conditions, and generally produces a hydrocracked naphtha fraction **326**, the diesel fuel fraction **322**, and an unconverted oil fraction **324**. The diesel fuel fraction **322** is recovered as fuel, for instance, compliant with Euro V diesel standards, and can be combined with the diesel fuel fraction **182** from the diesel hydrotreating zone **180**. In certain embodiments, all, a substantial portion, a significant portion or a major portion of the total vacuum gas oil **162** is routed to the vacuum gas oil hydrocracking zone **320**. The remainder (if any) can be routed directly to the gas oil steam cracking zone **250**, bypassing the vacuum gas oil hydrocracking zone. In addition to vacuum gas oil and optionally atmospheric gas oil, in certain embodiments the hydrocracking zone **320** can also process atmospheric and/or vacuum gas oil range products from an optional vacuum residue treatment zone **800**.

All, a substantial portion, a significant portion or a major portion of the hydrocracked naphtha fraction **326** from the vacuum gas oil hydrocracking zone **320** is routed to the mixed feed steam cracking zone **230**. Remaining wild naphtha (if any) can be added to a gasoline pool. In certain embodiments, the naphtha fraction **326** is routed through the crude complex **100**. In embodiments in which the hydrocracked naphtha fraction **326** is routed through the crude complex **100**, all or a portion of the liquefied petroleum gas

produced in the gas oil hydrocracking zone **320** can be passed with the hydrocracked naphtha fraction **326**.

All, a substantial portion or a significant portion of the unconverted oil fraction **324** from the vacuum gas oil hydrocracking zone **320** is routed to the gas oil steam cracking zone **250**. The remainder (if any) can be recycled and cracked to extinction and/or bled from the system and/or passed to the optional vacuum residue treating zone.

In certain embodiments, at least a major portion of a vacuum residue fraction **168** from the vacuum distillation zone **160** is passed to the optional vacuum residue treatment zone **800**. In certain embodiments, all, a substantial portion, a significant portion or a major portion of the total vacuum residue **168** is routed to the optional vacuum residue treatment zone **800**. The remainder (if any) is routed to the fuel oil pool (not shown). In addition, in certain embodiments, a minor portion of the atmospheric residue fraction **114** can bypass the vacuum distillation zone **160** (not shown) and be routed to the optional vacuum residue treatment zone **800**. In certain embodiments, all or a portion of a pyrolysis oil stream **218** from the steam cracker complex, for instance, shown as stream **902**, can be processed in the optional vacuum residue treatment zone **800**.

With reference to FIG. 2, the mixed feed steam cracking zone **230** and the gas oil steam cracking zone **250** operate to convert their respective feeds into ethylene **202**, propylene **204**, mixed C4s **206**, pyrolysis gasoline **212**, pyrolysis oil **218**, and off-gases **208** that can be passed to an integrated fuel gas system. Further, hydrogen **210** is recovered from the cracked products and can be recycled to hydrogen users within the complex limits. Not shown are the ethane and propane recycle, which are typical in steam cracking operations, although it is appreciated that in certain embodiments all or a portion of the ethane and propane can be diverted. In certain embodiments, all, a substantial portion, a significant portion or a major portion of ethane is recycled to the mixed feed steam cracking zone **230**, and all, a substantial portion, a significant portion or a major portion of propane is mixed feed steam cracking zone **230**. In certain embodiments hydrogen for all hydrogen users in the integrated process and system is derived from hydrogen **210** recovered from the cracked products, and no outside hydrogen is required once the process has completed start-up and reached equilibrium. In further embodiments excess hydrogen can be recovered.

For simplicity, operations in an olefins recovery train are not shown, but are well known and are considered part of the mixed feed steam cracking zone **230** and gas oil steam cracking zone **250** as described herein with respect to FIGS. 2, 3, 4 and 5.

The mixed C4s stream **206** containing a mixture of C4s from the steam cracker complex **230/250**, known as crude C4s, is routed to a butadiene extraction unit **500** to recover a high purity 1,3-butadiene product **502**. A first raffinate **504** ("C4-Raff-1") containing butanes and butenes is passed to a selective hydrogenation unit ("SHU") and methyl tertiary butyl ether ("MTBE") unit, SHU and MTBE zone **510**, where it is mixed with high purity fresh methanol **512** from outside battery limits to produce methyl tertiary butyl ether **514**.

A second raffinate **516** ("C4 Raff-2") from the SHU and MTBE zone **510** is routed to a C4 distillation unit **520** for separation into a 1-butene product stream **522** and an alkane stream **524** (a third raffinate "C4 Raff-3") containing residual C4s, all, a substantial portion, a significant portion or a major portion of which is recycled to the mixed feed steam cracking zone **230** although it is appreciated that in

certain embodiments all or a portion of the residual C4s can be diverted. Separation of the ethylene **202**, propylene **204** and the mixed C4s stream **206** occurs in a suitable arrangement of known separation steps for separating steam cracking zone effluents, including compression stage(s), depropanizer, debutanizer, demethanizer and deethanizer.

All, a substantial portion or a significant portion of the pyrolysis gasoline **212** from the steam cracker complex **230/250** is fed to a py-gas hydrotreatment and recovery center **600/620**. In certain embodiments, select hydrocarbons having 5-12 carbons are recovered from untreated pyrolysis gasoline and the remainder is subsequently hydrotreated for aromatics recovery. In a py-gas hydrotreating unit, diolefins and olefins in the pyrolysis gasoline are saturated.

Hydrotreated pyrolysis gasoline from the py-gas hydrotreating unit (in certain embodiments having C5s removed and recycled to the mixed feed steam cracking zone **230** instead of or in conjunction with C5s from the aromatics extraction zone **620**) is routed to the aromatics extraction zone **620**. The py-gas hydrotreating zone **600** and the aromatics extraction zone **620** are shown for simplicity in a single schematic block **600/620** in FIGS. 2, 3, 4 and 5.

The aromatics extraction zone **620** includes, for instance, one or more extractive distillation units, and operates to separate the hydrotreated pyrolysis gasoline into an aromatics stream **622** containing high-purity benzene, toluene, xylenes and C9 aromatics, which are recovered for chemical markets. C5 raffinate **606** and non-aromatics **646** (for instance, C6-C9) are recycled to the mixed feed steam cracking zone **230**. In certain embodiments, all, a substantial portion or a significant portion of the C5 raffinate **606** and non-aromatics **646** are passed to the mixed feed steam cracking zone **230**. A heavy aromatics stream **642** (for instance, C10-C12) can be used as an aromatic solvent, an octane boosting additive or as a cutter stock into a fuel oil pool. In certain embodiments ethylbenzene **628** can be recovered.

In certain embodiments, pyrolysis oil **218** can be blended into the fuel oil pool. In additional embodiments, pyrolysis oil **218** can be fractionated (not shown) into light pyrolysis oil and heavy pyrolysis oil. For instance, light pyrolysis oil can be blended with the first middle distillate stream **116** and/or the second middle distillate stream **122**, for processing to produce diesel fuel product and/or additional feed to the mixed feed steam cracking zone **230**. In further embodiments light pyrolysis oil derived from pyrolysis oil **218** can be processed in the vacuum gas oil hydrocracking zone **320**. In additional embodiments, light pyrolysis oil derived from pyrolysis oil **218** can be blended into the fuel oil pool. In further embodiments, light pyrolysis derived from pyrolysis oil **218** can be processed in the residue treating zone **800**. In certain embodiments, all, a substantial portion, a significant portion or a major portion of light pyrolysis oil derived from pyrolysis oil **218** can be passed to one or both of the diesel hydrotreating zone **180** and/or the vacuum gas oil hydrocracking zone **320**; any remainder can be blended into the fuel oil pool. Heavy pyrolysis oil can be blended into the fuel oil pool, used as a carbon black feedstock and/or processed in the optional residue treating zone **800**. In certain embodiments, all, a substantial portion, a significant portion or a major portion of the pyrolysis oil **218** (light and heavy) can be processed in the optional residue treating zone **800**.

FIG. 3 schematically depicts further embodiments of processes and systems for conversion of crude oil to petrochemicals and fuel products, with metathesis conversion of C4 and C5 olefins to produce additional propylene. The

process operates as described with respect to FIG. 1 upstream of the steam cracking operations.

Downstream of the steam cracking operations, the butadiene extraction train can optionally operate in a manner similar to that in FIG. 1 shown as the third C4 raffinate stream **524** from a diverter (in dashed lines) from the C4 distillation unit **520** directly to the mixed feed steam cracking zone **230**.

In a metathesis mode of operation, a mixed C4 raffinate stream **532** ("C4 Raff 3") from the C4 distillation unit **520** and C5 raffinate **540** from the py-gas hydrotreatment and recovery center **600/620** are routed to a metathesis unit **530** for metathesis conversion to additional propylene **534**. In certain embodiments, all, a substantial portion, a significant portion or a major portion of the cracked C5s from the py-gas hydrotreater can be routed to the metathesis unit **530** prior to aromatics extraction. As indicated, a portion **536** of the ethylene product **202** can be routed to the metathesis unit **530**. In additional embodiments, ethylene for the metathesis unit **530** is supplied from outside the complex limits, instead of or in addition to the portion **536** of the ethylene product **202**.

Selective recovery of various alkene and diene pyrolysis chemicals having four carbons, and metathesis conversion to produce additional propylene, is achieved using a metathesis unit **530**. A stream **538** containing a mixture of mostly saturated C4/C5 from the metathesis unit **530** is recycled to the mixed feed steam cracking unit **230**.

As in FIG. 2, in the configuration of FIG. 3, pyrolysis gasoline **212** from the steam cracker complex **230/250** is routed to the py-gas hydrotreatment and recovery center **600/620**; C6-C9 aromatics stream **622**, BTX, is recovered for chemical markets; C6-C9 non-aromatics stream **646** is recycled to the mixed feed steam cracking zone **230**; and the heavy aromatics stream **642** (for instance, C10-C12 products) is recovered. In certain embodiments ethylbenzene **628** can be recovered. In addition, in a metathesis mode of operation, a C5 raffinate is routed to the metathesis unit **530**, shown as stream **540**. Optionally C5 raffinate is recycled to the mixed feed steam cracking zone **230** (as in the embodiments of FIG. 2) via stream **606**, shown in dashed lines in FIG. 3. In certain embodiments (not shown), all or a portion of the cracked C5s from the py-gas hydrotreater can be routed to the metathesis unit **530** prior to aromatics extraction.

In the configuration depicted in FIG. 3, an optional diverter is shown, indicated as a diverter and stream in dashed lines, to bypass the metathesis conversion process, to therefore divert all, a substantial portion, a significant portion or a major portion of the third C4 raffinate stream **524** to the mixed feed steam cracking zone **230**. In a metathesis mode, flow can be directed to the metathesis conversion unit **530**. In further alternative modes, flow of the third C4 raffinate stream **524** can be directed to the mixed feed steam cracking zone **230** and the metathesis conversion unit **530**. In this manner, a producer can vary the quantity of feed to tailor the desired outputs. Accordingly, 0-100% of the third C4 raffinate stream **524** can be routed to the metathesis conversion unit **530**, and the remainder (if any) is directed to the mixed feed steam cracking zone **230**. The quantity can be determined, for instance, based upon demand for ethylene, demand for propylene, and/or minimum ranges for which the unit is operated depending on design capacity.

FIG. 4 schematically depicts further embodiments of processes and systems for conversion of crude oil to petrochemicals and fuel products. The process operates as described with respect to FIG. 1 upstream of the steam

cracking operations. In this embodiment, an additional step is provided to convert a mixture of butenes into mixed butanols suitable as a gasoline blending oxygenate and for octane enhancement. Suitable processes to convert a mixture of butenes into mixed butanols are described in one or more of commonly owned patent publications US20160115107A1, US20150225320A1, US20150148572A1, US20130104449A1, US20120245397A1 and commonly owned U.S. Pat. No. 9,447,346B2, U.S. Pat. No. 9,393,540B2, U.S. Pat. No. 9,187,388B2, U.S. Pat. No. 8,558,036B2, all of which are incorporated by reference herein in their entireties. In certain embodiments, a particularly effective conversion process known as "SuperButol™" technology is integrated, which is a one-step process that converts a mixture of butenes into mixed butanol liquids.

Downstream of the steam cracking operations, the butadiene extraction train can optionally operate in a manner similar to that in FIG. 2 shown as the stream **524** from a diverter (in dashed lines) from the C4 distillation unit **520** directly to the mixed feed steam cracking zone **230**. A mixed butanols production zone **550** is integrated for selective recovery of various alkene and diene pyrolysis chemicals having four carbons, and in certain processing arrangements hydrating a portion of those C4's in a butanol production unit (such as a "SuperButol™" unit) to produce high value fuel additives.

For instance, the mixed butanols production zone **550** operates to convert butenes to butanols from undervalued refinery/petrochemical mixed olefin streams. The butanols provide an alternative option for oxygenates in gasoline blends. The crude C4 processing center **550** includes the conversion reaction of butenes to butanols, for instance, in one or more high pressure catalytic reactors followed by gravity separation of butenes and butanols from water, and subsequent separation of the butanols product from butenes by distillation. Process stages include butenes and water make-up and recycle, butanol reaction, high pressure separation, low pressure separation, debutenizer distillation (product column) and an aqueous distillation column.

FIG. 4 depicts embodiments in which a C4 raffinate stream **552** containing butenes from the C4 distillation unit **520** routed to the mixed butanols production zone **550** to convert the mixture of butenes into mixed butanol liquids **554**. In certain embodiments, all, a substantial portion, a significant portion or a major portion of stream **552** is routed to the butanol production unit **550**. Alkanes **556** are recycled to the mixed feed steam cracking zone **230**.

As in FIGS. 1 and 2 in the configuration of FIG. 4, pyrolysis gasoline **212** from the steam cracker complex **230/250** is routed to the py-gas hydrotreatment and recovery center **600/620**; C6-C9 aromatics stream **622** are recovered for chemical markets, C5 raffinate **606** and non-aromatics **646** (for instance, C6-C9) can be recycled to the mixed feed steam cracking zone **230**, and the heavy aromatics stream **642** (for instance, C10-C12 products) is recovered. In certain embodiments ethylbenzene **628** can be recovered.

In the configuration depicted in FIG. 4, an optional diverter is shown, indicated as a diverter and stream in dashed lines, to bypass the process for conversion of a mixture of butenes into mixed butanols, to therefore divert all, a substantial portion, a significant portion or a major portion of the C4 Raff-3 **524** to the mixed feed steam cracking zone **230**. In a mixed butanol liquid mode of operation, flow can be directed to the mixed butanols production zone **550** for conversion of a mixture of butenes into mixed butanols. In further alternative modes, flow of the

C4 Raff-3 **524** can be directed to the mixed feed steam cracking zone **230** and the mixed butanols production zone **550**. In this manner, a producer can vary the quantity of feed to tailor the desired outputs. Accordingly, 0-100% of the third C4 raffinate stream **524** can be routed to mixed butanols production zone **550**, and the remainder (if any) is directed to the mixed feed steam cracking zone **230**. The quantity can be determined, for instance, based upon demand for ethylene, demand for mixed butanols, and/or minimum ranges for which the unit is operated depending on design capacity.

FIG. **5** schematically depicts further embodiments of processes and systems for conversion of crude oil to petrochemicals and fuel products. In this embodiment, additional step(s) of metathesis conversion of C4 and C5 olefins to produce additional propylene, and/or conversion of a mixture of butenes into mixed butanols suitable as a gasoline blending oxygenate and for octane enhancement, are integrated. The process operates as described with respect to FIG. **1** upstream of the steam cracking operations.

Downstream of the steam cracking operations, the butadiene extraction train can optionally operate in a manner similar to that in FIG. **2** shown as the stream **524** from a diverter (in dashed lines) from the C4 distillation unit **520** directly to the mixed feed steam cracking zone **230** as an optional mode of operation. The configuration in FIG. **5** integrates selective recovery of various alkene and diene pyrolysis chemicals having four carbons, metathesis conversion to produce additional propylene, and/or conversion of a mixture of butenes into mixed butanols suitable as a gasoline blending oxygenate and for octane enhancement.

FIG. **5** depicts a stream **552** containing butenes from the C4 distillation step ("C4 Raff-3") that can be routed to a mixed butanols production zone **550** for conversion of the mixture of butenes into mixed butanol liquids **554**. Alkanes **556** are recycled to the mixed feed steam cracking zone **230**. In addition, a portion **532** of the 2-butene rich raffinate-3 from the C4 distillation unit **520** is passed to a metathesis unit **530** for metathesis conversion to additional propylene **534**. As indicated, a portion **536** of the ethylene product **202** can be routed to the metathesis unit **530**. In additional embodiments, ethylene for the metathesis unit **530** is supplied from outside the complex limits, instead of or in addition to the portion **536** of the ethylene product **202**. A stream **538**, having a mixture of mostly saturated C4/C5 from metathesis unit, is recycled to the mixed feed steam cracking zone **230**.

As in FIG. **2**, in the configuration of FIG. **5**, pyrolysis gasoline **212** from the steam cracker complex **230/250** is routed to the py-gas hydrotreatment and recovery center **600/620**; C6-C9 aromatics stream **622**, BTX, is recovered for chemical markets; non-aromatics **646** (for instance, C6-C9) is recycled to the mixed feed steam cracking zone **230**, and the heavy aromatics stream **642** (for instance, C10-C12 products) is recovered. In certain embodiments ethylbenzene **628** can be recovered. The raffinate stream **540** can be routed to the metathesis unit **530**, as shown, and/or optionally recycled to the mixed feed steam cracking zone **230** as shown in dashed lines, stream **606**. In certain embodiments (not shown), all or a portion of the cracked C5s from the py-gas hydrotreater can be routed to the metathesis unit **530** prior to aromatics extraction.

In the configuration depicted in FIG. **5**, an optional diverter is shown, indicated as a diverter and stream in dashed lines, to bypass the metathesis conversion process and the process for conversion of a mixture of butenes into mixed butanols, to therefore divert all, a substantial portion,

a significant portion or a major portion of the C4 Raff-3 **524** to the mixed feed steam cracking zone **230**. An optional valve also can be provided to direct flow of the C4 Raff-3 to one or both of the metathesis conversion unit **530** and/or the mixed butanols production zone **550** for conversion of a mixture of butenes into mixed butanols. In further alternative modes, flow of the C4 Raff-3 **524** can be directed to each of the mixed feed steam cracking zone **230**, the metathesis conversion unit **530** (as stream **532**), and the mixed butanols production zone **550** (as stream **552**). In this manner, a producer can vary the quantity of feed to tailor the desired outputs. Accordingly, all, a substantial portion, a significant portion or a major portion of the third C4 raffinate stream can be routed to the metathesis conversion unit **530**, and the remainder (if any) is directed to the mixed feed steam cracking zone **230** and/or the mixed butanols production zone **550**. In certain embodiments, all, a substantial portion, a significant portion or a major portion of the third C4 raffinate stream is routed to the metathesis conversion unit **530**, and the remainder (if any) is directed to the mixed feed steam cracking zone **230**. In further embodiments, all, a substantial portion, a significant portion or a major portion of the third C4 raffinate stream is routed to the metathesis conversion unit **530**, and the remainder (if any) is directed to the mixed feed steam cracking zone **230** and the metathesis conversion unit **530**. In further embodiments, all, a substantial portion, a significant portion or a major portion of the third C4 raffinate stream is routed to the mixed butanols production zone **550** for production of mixed butanols, and the remainder (if any) is directed to both the mixed feed steam cracking zone **230** and the metathesis conversion unit **530**. In further embodiments, all, a substantial portion, a significant portion or a major portion of the third C4 raffinate stream is routed to the mixed butanols production zone **550** for production of mixed butanols, and the remainder (if any) is directed to the mixed feed steam cracking zone **230**. In further embodiments, all, a substantial portion, a significant portion or a major portion of the third C4 raffinate stream is routed to the mixed butanols production zone **550** for production of mixed butanols, and the remainder (if any) is directed to the mixed feed steam cracking zone **230**. In further embodiments, all, a substantial portion, a significant portion or a major portion of the third C4 raffinate stream is routed to the mixed butanols production zone **550** for production of mixed butanols, and the remainder (if any) is directed to the metathesis conversion unit **530**. The quantity can be determined, for instance, based upon demand for ethylene, demand for propylene, demand for mixed butanols, and/or minimum ranges for which the unit is operated depending on design capacity.

FIGS. **6** and **10** schematically depict embodiments of processes and systems for conversion of crude oil to petrochemicals and fuel products including a mixed feed steam cracking zone **230** and a gas oil steam cracking zone **250**.

A crude oil feed **102** is passed to a crude complex **100**, which generally includes an atmospheric distillation zone **110**, a saturated gas plant **150** and a vacuum distillation zone **160**. The atmospheric distillation unit and vacuum distillation unit are used in well-known arrangements.

Intermediate streams obtained from the feed **102** via separation in the crude complex **100** include: off-gas **154**, obtained within the crude complex **100** via the saturated gas plant **150**, and the sweet off-gas can be sent to the fuel gas system or to the steam cracker complex; a light ends stream **152**, obtained within the crude complex **100** via the saturated gas plant **150**, and which is passed to the mixed feed steam cracking zone **230**; one or more straight run naphtha stream (s), in this embodiment a light naphtha stream **138** and a heavy naphtha stream **140**, which are passed to the mixed feed steam cracking zone **230**; a first middle distillate stream **116** that is passed to a kerosene sweetening zone **170**, such as a mercaptan oxidation zone; a second middle distillate

stream **122** that is passed to a diesel hydrotreating zone **180**; a third middle distillate stream **126** that can be passed to the gas oil hydrocracking zone **320**, the gas oil steam cracking zone **250**, or both the gas oil hydrocracking zone **320** and the gas oil steam cracking zone **250**; an atmospheric residue fraction **114** that is passed to the vacuum distillation zone **160**; a light vacuum gas oil stream **164** and a heavy vacuum gas oil stream **166** from the vacuum distillation zone **160** that are passed to the vacuum gas oil hydrocracking zone **320**; and a vacuum residue stream **168** from the vacuum distillation zone **160**, all or a portion of which can optionally be passed to a residue treating zone **800**, and/or to a fuel oil pool. In certain embodiments the third middle distillate stream **126** is routed to both the gas oil hydrocracking zone **320** and the gas oil steam cracking zone **250**. For instance, the third middle distillate stream **126** can be two separate temperature fractions of an atmospheric gas oil stream from the crude complex **100**, including heavy AGO that is passed to the gas oil hydrocracking zone **320**, and medium AGO (if not contained in the second middle distillate fraction **122**) that bypasses the gas oil hydrocracking zone **320** and is directly routed to the gas oil steam cracking zone **250** without hydrocracking. In another arrangement, the third middle distillate stream **126** can be divided based on volume or mass flow, for instance, with a diverter.

The intermediate streams from the crude complex **100** are used in an efficient manner in the integrated process and system herein. The light ends stream **152**, and the straight run naphtha stream(s), in this embodiment light naphtha **138** and heavy naphtha **140**, are routed to the mixed feed steam cracking zone **230** as feed for conversion into light olefins and other valuable petrochemicals. Either or both of the straight run naphtha streams, light naphtha **138** and heavy naphtha **140**, can optionally be steam-stripped in a side stripper prior to routing to the mixed feed steam cracking zone **230**.

Components of the crude complex not shown but which are well-known can include feed/product and pump-around heat exchangers, crude charge heaters, crude tower(s), product strippers, cooling systems, hot and cold overhead drum systems including re-contactors and off-gas compressors, and units for water washing of overhead condensing systems. The atmospheric distillation zone **110** can include well-known design features. Furthermore, in certain embodiments, all or portions of the naphtha, kerosene and atmospheric gas oil products from the atmospheric distillation column are steam-stripped in side strippers, and atmospheric residue is steam-stripped in a reduced-size can section inside the bottom of the atmospheric distillation column.

The feed to the atmospheric distillation zone **110** is primarily the crude feed **102**, although it shall be appreciated that wild naphtha, LPGs and off-gas streams from the diesel hydrotreating zone **180**, the vacuum gas oil hydrocracking zone **320**, and in certain embodiments from an optional residue treating zone, can be routed to the atmospheric distillation zone **110** where they are fractionated before being passed to the cracking complex. A desalting unit (not shown) is typically included upstream of the distillation zone **110**. A substantial amount of the water required for desalting can be obtained from a sour water stripper within the integrated process and system.

The desalting unit refers to a well-known arrangement of vessels for desalting of crude oil, and as used herein is operated to reduce the salt content to a target level, for instance, to a level of less than or equal to about 10, 5, or 3

wppm. In certain embodiments two or more desalters are included to achieve a target salt content of less than or equal to about 3 wppm.

In one embodiment of a crude complex **100** herein, feed **102** is preheated before entering a desalting unit, for instance, to a temperature ($^{\circ}$ C.) in the range of about 105-165, 105-150, 105-145, 120-165, 120-150, 120-145, 125-165, 125-150, 125-145, and in certain embodiments about 135. Suitable desalters are designed to remove salt down to a typical level of about 0.00285 kg/m³ (1 lb/1000 bbl) in a single stage. In certain embodiments, plural preheat and desalting trains are employed. The desalter operating pressure can be based on a pressure margin above crude and water mixture vapor pressure at desalter operating temperature to ensure liquid phase operation, for instance in the range of about 2.75-4.15, 2.75-3.80, 2.75-3.65, 3.10-4.15, 3.10-3.80, 3.10-3.65, 3.25-4.15, 3.25-3.80, 3.25-3.65 and in certain embodiments about 3.45 barg.

The atmospheric distillation zone **110** can employ fractionated products and pumparounds to provide enough heat for desalting. In certain embodiments, the desalter operating temperature can be controlled by a diesel pumparound swing heat exchanger. In certain embodiments, desalter brine preheats desalter make-up water in a spiral type heat exchanger to minimize fouling and achieve rundown cooling against cooling water before the brine is routed to the wastewater system.

In certain embodiments, desalted crude is preheated before entering a preflash tower, to a temperature ($^{\circ}$ C.) in the range of about 180-201, 185-196, or 189-192. The preflash tower removes LPG and light naphtha from the crude before it enters the final preheat exchangers. The preflash tower minimizes the operating pressure of the preheat train to maintain liquid phase operation at the crude furnace pass valves and also reduces the requisite size of the main crude column.

In one example of a suitable crude distillation system, a crude furnace vaporizes materials at or below a certain cut point, for instance, at a temperature ($^{\circ}$ C.) in the range of about 350-370, 355-365 or 360 (680 $^{\circ}$ F.), before the crude enters the flash zone of the crude tower. The furnace is designed for a suitable outlet temperature, for instance, at a temperature ($^{\circ}$ C.) in the range of about 338-362, 344-354 or 348.9 (660 $^{\circ}$ F.). Crude column flash zone conditions are at a temperature ($^{\circ}$ C.) in the range about 328-374, 328-355, 337-374, 327-355, or 346.1 (655 $^{\circ}$ F.), and a pressure (barg) in the range of about 1.35-1.70, 1.35-1.60, 1.44-1.70, 1.44-1.60 or 1.52.

In certain embodiments the crude tower contains 59 trays and produces six cuts, with draw temperatures for each product as follows: light naphtha, 104.4 $^{\circ}$ C. (220 $^{\circ}$ F.) (overhead vapor); heavy naphtha, 160.6 $^{\circ}$ C. (321 $^{\circ}$ F.) (sidedraw); kerosene, 205 $^{\circ}$ C. (401 $^{\circ}$ F.) (sidedraw); diesel, 261.7 $^{\circ}$ C. (503 $^{\circ}$ F.) (sidedraw); AGO, 322.2 $^{\circ}$ C. (612 $^{\circ}$ F.) (sidedraw); atmospheric residue, 340.6 $^{\circ}$ C. (645 $^{\circ}$ F.) (bottoms). The heavy naphtha draw includes a reboiled side stripper against diesel pumparound, and is controlled to a 185 $^{\circ}$ C. (365 $^{\circ}$ F.) D86 end point. The kerosene draw includes a steam stripper at 14.54 kg/m³ (5.1 lb steam per bbl); the draw rate is limited on the back end by freeze point. The diesel draw includes a steam stripper at 14.54 kg/m³ (5.1 lb steam per bbl), and this draw is controlled to a 360 $^{\circ}$ C. (680 $^{\circ}$ F.) D86 95% point. The AGO draw includes a steam stripper at 14.82 kg/m³ (5.2 lb steam per bbl), which sets the overflash at 2 vol % on crude. The crude tower also contains 3 pumparounds for top, diesel, and AGO. Diesel pump-around provides heat to the heavy naphtha stripper reboiler

and debutanizer reboiler along with controlling desalter operating temperature via swing heat. The bottoms stream of the atmospheric column is steam stripped at 28.5 kg/m³ (10 lb steam/bbl).

The atmospheric residue fraction **114** from the atmospheric distillation zone **110** is further distilled in the vacuum distillation zone **160**, which fractionates the atmospheric residue fraction **114** into vacuum gas oil fractions, shown as a light vacuum gas oil stream **164** and a heavy vacuum gas oil stream **166**, and a vacuum residue stream **168**. Vacuum gas oil from streams **164** and **166** is routed to the vacuum gas oil hydrocracking zone **320**. The vacuum residue stream **168** can be routed to a fuel oil pool (such as a high sulfur fuel oil pool), or in certain embodiments, passed to a residue treating zone **800**.

The vacuum distillation zone **160** can include well-known design features, such as operation at reduced pressure levels (mm Hg absolute pressure), for instance, in the range of about 30-40, 32-36 or 34, which can be maintained by steam ejectors or mechanical vacuum pumps. Vacuum bottoms can be quenched to minimize coking, for instance, via exchange against crude at a temperature (° C.) in the range of about 334-352, 334-371, 338-352, 338-371 or 343.3 (650° F.). Vacuum distillation can be accomplished in a single stage or in plural stages. In certain embodiments, the atmospheric residue fraction **114** is heated in a direct fired furnace and charged to vacuum fractionator at a temperature (° C.) in the range of about 390-436, 390-446, 380-436, 380-446 or 400-425.

In one embodiment, the atmospheric residue is heated to a temperature (° C.) in the range of about 399-420, 399-430, 389-420, 389-430 or 409.4 (769° F.) in the vacuum furnace to achieve flash zone conditions of a temperature (° C.) in the range of about 392-412, 392-422, 382-412, 382-422 or 401.7 (755° F.) and pressure levels (mm Hg absolute pressure) in the range of about 30-40, 32-36 or 34. The vacuum column is designed for a theoretical cut point temperature (° C.) in the range of about 524-551, 524-565, 511-551, 511-565 or 537.8 (1000° F.), by removing light VGO and heavy VGO from the vacuum residue. The overhead vacuum system can include two parallel trains of jet ejectors each including three jets. A common vacuum pump is used at the final stage. In one embodiment, the vacuum tower is sized for a 0.35 C-Factor and about a 14.68 lpm/m² (0.3 gpm/ft²) wetting rate at the bottom of the wash zone. Wash zone slop wax is recycled to the vacuum furnace to minimize fuel oil production. Vacuum bottoms are quenched via exchange against crude to minimize coking at a temperature (° C.) in the range of about 334-352, 334-371, 338-352, 338-371 or 343.3° C. (650° F.).

The saturated gas plant **150** generally comprises a series of operations including fractionation and in certain systems absorption and fractionation, as is well known, with an objective to process light ends to separate fuel gas range components from LPG range components suitable as a steam cracker feedstock. The light ends that are processed in one or more saturated gas plants within embodiments of the integrated system and process herein are derived from the crude distillation, such as light ends and LPG. In addition, other light products can optionally be routed to the saturated gas plant **150**, shown in dashed lines as stream **156**, such as light gases from refinery units within the integrated system, and in certain embodiments light gases from outside of the battery limits. For instance, stream **156** can contain off-gases and light ends from the diesel hydrotreating zone **180**, the gas oil hydrocracking zone **320** and/or from the py-gas hydrotreating zone **600**. The products from the saturated gas

plant **150** include: an off-gas stream **154**, containing C1-C2 alkanes that is passed to the fuel gas system and/or the steam cracker complex; and a light ends stream **152**, containing C2+, that is passed to the mixed feed steam cracking unit **230**.

In certain embodiments, a suitable saturated gas plant **150** includes amine and caustic washing of liquid feed, and amine treatment of vapor feed, before subsequent steps. The crude tower overhead vapor is compressed and recontacted with naphtha before entering an amine scrubber for H₂S removal and is then routed to the steam cracker complex. Recontact naphtha is debutanized to remove LPGs which are amine washed and routed to the steam cracker complex. The debutanized naphtha is routed separately from the heavy naphtha to the steam cracker complex. As is known, light naphtha absorbs C4 and heavier hydrocarbons from the vapor as it travels upward through an absorber/debutanizer. Off-gas from the absorber/debutanizer is compressed and sent to a refinery fuel gas system. A debutanizer bottoms stream is sent to the mixed feed steam cracker as an additional source of feed.

As shown, the first middle distillate fraction **116** is processed in a kerosene sweetening zone **170** to remove unwanted sulfur compounds, as is well-known. Treated kerosene is recovered as a kerosene fuel product **172**, for instance, jet fuel compliant with Jet A or Jet A-1 specifications, and optionally other fuel products. In certain embodiments herein, all or a portion of the first middle distillate fraction **116** is not used for fuel production, but rather is used as a feed for distillate hydroprocessing so as to produce additional feed for the mixed feed steam cracking zone **230**.

For instance, a suitable kerosene sweetening zone **170** can include, but is not limited to, systems based on Merox™ technology (Honeywell UOP, US), Sweetn'K technology (Axens, IFP Group Technologies, FR) or Thiolex™ technology (Merichem Company, US). Processes of these types are well-established commercially and appropriate operating conditions are well known to produce fuel product **172** and disulfide oils as by-products. In certain kerosene sweetening technologies, impregnated carbon is utilized as catalyst to promote conversion to disulfide oil. In certain embodiments, common treatment of sour water from the kerosene sweetening zone **170** and other unit operations is employed to maximize process integration.

For example, one arrangement of a kerosene sweetening zone includes caustic wash of the kerosene feed for residual H₂S removal, employing an electrostatic coalescer (for instance using 10 degrees Baumé). The reactor vessel containing an effective quantity of activated carbon catalyst utilizes air in conjunction with the caustic solution to affect the oxidation of mercaptan to disulfides. Caustic is separated from treated kerosene in the bottom section of the reactor. After water washing, kerosene product passes upwards through one of two parallel salt filters to remove free water and some soluble water. The kerosene product passes downward through one of two parallel clay filters for removal of solids, moisture, emulsions and surfactants, so as to ensure that the kerosene product meets haze, color stability and water separation specifications, for instance, compliant with Jet A specifications.

The second middle distillate fraction **122** is processed in a diesel hydrotreating zone **180** in the presence of an effective amount of hydrogen obtained from recycle within the diesel hydrotreating zone **180** and make-up hydrogen **186**. In certain embodiments, all or a portion of the make-up hydrogen **186** is derived from the steam cracker hydrogen stream **210** from the olefins recovery train **270**. A suitable

hydrotreating zone **180** can include, but is not limited to, systems based on technology commercially available from Honeywell UOP, US; Chevron Lummus Global LLC (CLG), US; Axens, IFP Group Technologies, FR; Haldor Topsoe A/S, DK; or joint technology from KBR, Inc, US, and Shell Global Solutions, US.

The diesel hydrotreating zone **180** operates under conditions effective for removal of a significant amount of the sulfur and other known contaminants, for instance, to meet necessary sulfur specifications for the diesel fuel fraction **182**, such as diesel fuel compliant with Euro V diesel standards. In addition, a hydrotreated naphtha fraction **184** (sometimes referred to as wild naphtha) is recovered from the diesel hydrotreating zone **180**, which is routed to the mixed feed steam cracking zone **230** as one of plural steam cracking feed sources. Effluent off-gases are recovered from the diesel hydrotreating zone **180** and are passed to the olefins recovery train, the saturated gas plant as part of the other gases stream **156**, and/or directly to a fuel gas system. Liquefied petroleum gas can be recovered from the diesel hydrotreating zone **180** and routed to the mixed feed steam cracking zone, the olefins recovery train and/or the saturated gas plant. In certain embodiments, the hydrotreated naphtha fraction **184** is routed through the crude complex **100**, alone, or in combination with other wild naphtha fractions from within the integrated process. In embodiments in which hydrotreated naphtha fraction **184** is routed through the crude complex **100**, all or a portion of the liquefied petroleum gas produced in the diesel hydrotreating zone **180** can be passed with the hydrotreated naphtha fraction **184**. In certain embodiments, all, a substantial portion or a significant portion of the wild naphtha **184** is routed to the mixed feed steam cracking zone **230** (directly or through the crude complex **100**).

The diesel hydrotreating zone **180** can optionally process other fractions from within the complex (not shown). In embodiments in which a kerosene sweetening zone **170** is used, all or a portion of the disulfide oil can be additional feed to the diesel hydrotreating zone **180**. Further, all or a portion of the first middle distillate fraction **116** can be additional feed to the diesel hydrotreating zone **180**. Additionally, all or a portion of distillates from the vacuum gas oil hydrocracking zone **320**, and/or all or a portion of distillates from the optional vacuum residue treatment zone, can be routed to the diesel hydrotreating zone **180**. Any portion of distillates not routed to the diesel hydrotreating zone **180** can be passed to the crude complex **100** or routed to the mixed feed steam cracking zone **230**. Further, all or a portion of light pyrolysis oil can be routed to the diesel hydrotreating zone **180**.

The diesel hydrotreating zone **180** can contain one or more fixed-bed, ebullated-bed, slurry-bed, moving bed, continuous stirred tank (CSTR) or tubular reactors, in series and/or parallel arrangement. In certain embodiments, the diesel hydrotreating zone **180** contains a layered bed reactor with three catalyst beds and having inter-bed quench gas, and employs a layered catalyst system with the layer of hydrodewaxing catalyst positioned between beds of hydrotreating catalyst. Additional equipment, including exchangers, furnaces, feed pumps, quench pumps, and compressors to feed the reactor(s) and maintain proper operating conditions, are well known and are considered part of the diesel hydrotreating zone **180**. In addition, equipment including pumps, compressors, high temperature separation vessels, low temperature separation vessels and the like to separate reaction products and provide hydrogen recycle

within the diesel hydrotreating zone **180**, are well known and are considered part of the diesel hydrotreating zone **180**.

In certain embodiments, the diesel hydrotreating zone **180** operating conditions include:

a reactor inlet temperature ($^{\circ}$ C.) in the range of from about 296-453, 296-414, 296-395, 336-453, 336-414, 336-395, 355-453, 355-414, 355-395 or 370-380;

a reactor outlet temperature ($^{\circ}$ C.) in the range of from about 319-487, 319-445, 319-424, 361-487, 361-445, 361-424, 382-487, 382-445, 382-424 or 400-406;

a start of run (SOR) reaction temperature ($^{\circ}$ C.), as a weighted average bed temperature (WABT), in the range of from about 271-416, 271-379, 271-361, 307-416, 307-379, 307-361, 325-416, 325-379, 325-361 or 340-346;

an end of run (EOR) reaction temperature ($^{\circ}$ C.), as a WABT, in the range of from about 311-476, 311-434, 311-414, 352-476, 352-434, 352-414, 373-476, 373-434, 373-414 or 390-396;

a reaction inlet pressure (barg) in the range of from about 48-72, 48-66, 48-63, 54-72, 54-66, 54-63, 57-72, 57-66 or 57-63;

a reaction outlet pressure (barg) in the range of from about 44-66, 44-60, 44-58, 49-66, 49-60, 49-58, 52-66, 52-60 or 52-58;

a hydrogen partial pressure (barg) (outlet) in the range of from about 32-48, 32-44, 32-42, 36-48, 36-44, 36-42, 38-48, 38-44 or 38-42;

a hydrogen treat gas feed rate (standard liters per liter of hydrocarbon feed, SLt/Lt) up to about 400, 385, 353 or 337, in certain embodiments from about 256-385, 256-353, 256-337, 289-385, 289-353, 289-337, 305-385, 305-353 or 305-337;

a hydrogen quench gas feed rate (SLt/Lt) up to about 100, 85, 78 or 75, in certain embodiments from about 57-85, 57-78, 57-75, 64-85, 64-78, 64-75, 68-85, 68-78 or 68-75; and

a make-up hydrogen feed rate (SLt/Lt) up to about 110, 108, 100 or 95, in certain embodiments from about 70-108, 70-100, 70-95, 80-108, 80-100, 80-95, 85-108, 85-100 or 85-95.

An effective quantity of hydrotreating catalyst is provided in the diesel hydrotreating zone **180**, including those possessing hydrotreating functionality and which generally contain one or more active metal component of metals or metal compounds (oxides or sulfides) selected from the Periodic Table of the Elements IUPAC Groups 6-10. In certain embodiments, the active metal component is one or more of Co, Ni, W and Mo. The active metal component is typically deposited or otherwise incorporated on a support, such as amorphous alumina, amorphous silica alumina, zeolites, or combinations thereof. The catalyst used in the diesel hydrotreating zone **180** can include one or more catalyst selected from Co/Mo, Ni/Mo, Ni/W, and Co/Ni/Mo. Combinations of one or more of Co/Mo, Ni/Mo, Ni/W and Co/Ni/Mo, can also be used. The combinations can be composed of different particles containing a single active metal species, or particles containing multiple active species. In certain embodiments, Co/Mo hydrodesulfurization catalyst is suitable. Effective liquid hourly space velocity values (h^{-1}), on a fresh feed basis relative to the hydrotreating catalysts, are in the range of from about 0.1-10.0, 0.1-5.0, 0.1-2.0, 0.3-10.0, 0.3-5.0, 0.3-2.0, 0.5-10.0, 0.5-5.0, 0.5-2.0 or 0.8-1.2. Suitable hydrotreating catalysts used in the diesel hydrotreating zone **180** have an expected lifetime in the range of about 28-44, 34-44, 28-38 or 34-38 months.

In certain embodiments, an effective quantity of hydrodewaxing catalyst is also added. In such embodiments, effec-

tive hydrodewaxing catalysts include those typically used for isomerizing and cracking paraffinic hydrocarbon feeds to improve cold flow properties, such as catalysts comprising Ni, W, or molecular sieves or combinations thereof. Catalyst comprising Ni/W, zeolite with medium or large pore sizes, or a combination thereof are suitable, along with catalyst comprising aluminosilicate molecular sieves such as zeolites with medium or large pore sizes. Effective commercial zeolites include for instance ZSM-5, ZSM-11, ZSM-12, ZSM-22, ZSM-23, ZSM 35, and zeolites of type beta and Y. Hydrodewaxing catalyst is typically supported on an oxide support such as Al₂O₃, SiO₂, ZrO₂, zeolites, zeolite-alumina, alumina-silica, alumina-silica-zeolite, activated carbon, and mixtures thereof. Effective liquid hourly space velocity values (h⁻¹), on a fresh feed basis relative to the hydrodewaxing catalyst, are in the range of from about 0.1-12.0, 0.1-8.0, 0.1-4.0, 0.5-12.0, 0.5-8.0, 0.5-4.0, 1.0-12.0, 1.0-8.0, 1.0-4.0 or 1.6-2.4. Suitable hydrodewaxing catalysts used in the diesel hydrotreating zone **180** have an expected lifetime in the range of about 28-44, 34-44, 28-38 or 34-38 months.

In high capacity operations, two or more parallel trains of reactors are utilized. In such embodiments, the flow in the diesel hydrotreating zone **180** is split after the feed pump into parallel trains, wherein each train contains feed/effluent heat exchangers, feed heater, a reactor and the hot separator. Each reactor contains three catalyst beds with inter-bed quench gas. A layered catalyst system is used with the layer of hydrodewaxing catalyst positioned between beds of hydrotreating catalyst. The trains recombine after the hot separators. Tops from the hot separators are combined and passed to a cold separator. Bottoms from the hot separators and from the cold separator are passed to a product stripper to produce stabilized ultra-low sulfur diesel and wild naphtha. Tops from the cold separator are subjected to absorption and amine scrubbing. Recycle hydrogen is recovered, and passed (along with make-up hydrogen) to the reaction zone as treat gas and quench gas.

The light vacuum gas oil stream **164** and heavy vacuum gas oil stream **166** (or full range VGO, not shown) are processed in a gas oil hydrocracking zone **320** in the presence of an effective amount of hydrogen obtained from recycle within the gas oil hydrocracking zone **320** and make-up hydrogen **302**. In certain embodiments, all or a portion of the make-up hydrogen **302** is derived from the steam cracker hydrogen stream **210** from the olefins recovery train **270**. In certain embodiments (shown in dashed lines in FIG. 6), all or a portion of the heavy middle distillate fraction, such as a portion of the third middle distillate fraction **126**, e.g., atmospheric gas oil from the atmospheric distillation zone **110**, can be treated in the gas oil hydrocracking zone. The heavy middle distillate fraction can include a full range atmospheric gas oil, or a fraction thereof such as heavy atmospheric gas oil. Further, a portion of the third middle distillate fraction **126** can be routed to the gas oil hydrocracking zone **320**, while the remainder bypasses gas oil hydrocracking zone **320** and is directly routed to the gas oil steam cracking zone **250** without hydroprocessing. In certain embodiments, all, a substantial portion, a significant portion or a major portion of the combined vacuum gas oil, streams **164** and **166**, is routed to the vacuum gas oil hydrocracking zone **320**; the remainder of vacuum gas oil (if any) can be routed directly to the gas oil steam cracking zone **250**, bypassing the vacuum gas oil hydrocracking zone.

In accordance with the process herein, the severity of the gas oil hydrocracking operation can be used to moderate the relative yield of olefin and aromatic chemicals from the

overall complex and improve the economic threshold of cracking heavy feeds. This application of a gas oil hydrocracking zone, as a chemical yield control mechanism, is uncommon in the industry, where fuels products are typically the product objectives.

Hydrocracking processes are used commercially in a large number of petroleum refineries. They are used to process a variety of feeds boiling above the atmospheric gas oil range (for example, in the range of about 370 to 520° C.) in conventional hydrocracking units and boiling above the vacuum gas oil range (for example, above about 520° C.) in residue hydrocracking units. In general, hydrocracking processes split the molecules of the feed into smaller, i.e., lighter, molecules having higher average volatility and economic value. Additionally, hydrocracking processes typically improve the quality of the hydrocarbon feedstock by increasing the hydrogen-to-carbon ratio and by removing organosulfur and organonitrogen compounds. The significant economic benefit derived from hydrocracking processes has resulted in substantial development of process improvements and more active catalysts.

Three major hydrocracking process schemes include single-stage once through hydrocracking, series-flow hydrocracking with or without recycle, and two-stage recycle hydrocracking. Single-stage once through hydrocracking is the simplest of the hydrocracker configuration and typically occurs at operating conditions that are more severe than hydrotreating processes, and less severe than conventional higher pressure hydrocracking processes. It uses one or more reactors for both treating steps and cracking reaction, so the catalyst must be capable of both hydrotreating and hydrocracking. This configuration is cost effective, but typically results in relatively low product yields (for example, a maximum conversion rate of about 50 wt %). Single stage hydrocracking is often designed to maximize mid-distillate yield over a single or dual catalyst systems. Dual catalyst systems can be used in a stacked-bed configuration or in two different reactors. The effluents are passed to a fractionator column to separate the H₂S, NH₃, light gases (C₁-C₄), naphtha and diesel products, boiling in the temperature range including and below atmospheric gas oil range fractions (for instance in the temperature range of 36-370° C.). The hydrocarbons boiling above the atmospheric gas oil range (for instance 370° C.) are typically unconverted oils. Any portion of these unconverted oils that are not recycled are drawn from a bottoms fraction in a gas oil hydrocracking zone **320** as a hydrogen-rich bleed stream and is effectively integrated as feed to the gas oil steam cracking zone **250** as described herein. In certain embodiments, unconverted oils can be processed in a lube oil production unit (not shown).

The gas oil hydrocracking zone **320** operates under mild, moderate or severe hydrocracking conditions, and generally produces off-gas and light ends (not shown), a wild naphtha stream **326**, a diesel fuel fraction **322**, and an unconverted oil fraction **324**. Effluent off-gases are recovered from the gas oil hydrocracking zone **320** and are passed to the olefins recovery train, the saturated gas plant as part of the other gases stream **156**, and/or directly to a fuel gas system. Liquefied petroleum gas can be recovered from the gas oil hydrocracking zone **320** and routed to the mixed feed steam cracking zone, the olefins recovery train and/or the saturated gas plant. The naphtha fraction **326** is routed to the mixed feed steam cracking zone **230**. In certain embodiments, the naphtha fraction **326** is routed through the crude complex **100**, alone, or in combination with other wild naphtha fractions from within the integrated process. In embodiments in which naphtha fraction **326** is routed through the

crude complex **100**, all or a portion of the liquefied petroleum gas produced in the gas oil hydrocracking zone **320** can be passed with the naphtha fraction **326**. The unconverted oil fraction **324** is routed to the gas oil steam cracking zone **250**. The diesel fuel fraction **322** is recovered as fuel, for instance, compliant with Euro V diesel standards, and can be combined with the diesel fuel fraction **182** from the diesel hydrotreating zone **180**.

Vacuum gas oil hydrocracking zone **320** can operate under mild, moderate or severe conditions, depending on factors including the feedstock and the desired degree of conversion. Such conditions are effective for removal of a significant amount of the sulfur and other known contaminants, and for conversion of the feed(s) into a major proportion of hydrocracked products and minor proportions of off-gases, light ends and unconverted product that is passed to the gas oil steam cracking zone **250**.

For instance, a suitable vacuum gas oil hydrocracker zone **320** can include, but is not limited to, systems based on technology commercially available from Honeywell UOP, US; Chevron Lummus Global LLC (CLG), US; Axens, IFP Group Technologies, FR; or Shell Global Solutions, US.

The gas oil hydrocracking zone **320** can contain one or more fixed-bed, ebullated-bed, slurry-bed, moving bed, continuous stirred tank (CSTR) or tubular reactors, in series and/or parallel arrangement. Additional equipment, including exchangers, furnaces, feed pumps, quench pumps, and compressors to feed the reactor(s) and maintain proper operating conditions, are well known and are considered part of the gas oil hydrocracking zone **320**. In addition, equipment, including pumps, compressors, high temperature separation vessels, low temperature separation vessels and the like to separate reaction products and provide hydrogen recycle within the gas oil hydrocracking zone **320**, are well known and are considered part of the gas oil hydrocracking zone **320**.

Series-flow hydrocracking with or without recycle is one of the most commonly used configuration. It uses one reactor (containing both treating and cracking catalysts) or two or more reactors for both treating and cracking reaction steps. In a series-flow configuration the entire hydrocracked product stream from the first reaction zone, including light gases (typically C₁-C₄, H₂S, NH₃) and all remaining hydrocarbons, are sent to the second reaction zone. Unconverted bottoms from the fractionator column are recycled back into the first reactor for further cracking. This configuration converts heavy crude oil fractions such as vacuum gas oil, into light products and has the potential to maximize the yield of naphtha, kerosene and or diesel range hydrocarbons, depending on the recycle cut point used in the distillation section.

Two-stage recycle hydrocracking uses two reactors and unconverted bottoms from the fractionation column are passed to the second reactor for further cracking. Since the first reactor accomplishes both hydrotreating and hydrocracking, the feed to second reactor is virtually free of ammonia and hydrogen sulfide. This permits the use of high performance zeolite catalysts which are susceptible to poisoning by sulfur or nitrogen compounds.

Effective hydrocracking catalyst generally contain about 5-40 wt % based on the weight of the catalyst, of one or more active metal component of metals or metal compounds (oxides or sulfides) selected from the Periodic Table of the Elements IUPAC Groups 6-10. In certain embodiments, the active metal component is one or more of Mo, W, Co or Ni. The active metal component is typically deposited or otherwise incorporated on a support, such as amorphous alu-

mina, amorphous silica alumina, zeolites, or combinations thereof. In certain embodiments, alone or in combination with the above metals, Pt group metals such as Pt and/or Pd, may be present as a hydrogenation component, generally in an amount of about 0.1-2 wt % based on the weight of the catalyst. Suitable hydrocracking catalyst have an expected lifetime in the range of about 18-30, 22-30, 18-26 or 22-26 months.

Exemplary products from the gas oil hydrocracking zone **320** include 27-99, 27-90, 27-82, 27-80, 27-75, 27-52, 27-48, 30-99, 30-90, 30-82, 30-80, 30-75, 30-52, 30-48, 48-99, 48-90, 48-82, 48-80, 48-75, 48-52, 78-99, 78-90, 78-85, 80-90 or 80-99 wt % of effluent (relative to the feed to the gas oil hydrocracking zone **320**) boiling at or below the atmospheric residue end boiling point, such as 370° C., including LPG, kerosene, naphtha, and atmospheric gas oil range components. The remaining bottoms fraction is the unconverted oil fraction, all or a portion of which can be effectively integrated as feed to the gas oil steam cracking zone **250** as described herein.

FIG. 7 schematically depicts embodiments of a once-through single reactor hydrocracking zone **330** including a reaction zone **332** and a fractionating zone **342**, which can as a mild conversion or partial conversion hydrocracker.

Reaction zone **332** generally includes one or more inlets in fluid communication with a source of initial feedstock **334** and a source of hydrogen gas **338**. One or more outlets of reaction zone **332** that discharge effluent stream **340** is in fluid communication with one or more inlets of the fractionating zone **342** (typically including one or more high pressure and/or low pressure separation stages therebetween for recovery of recycle hydrogen, not shown).

Fractionating zone **342** includes one or more outlets for discharging gases **344**, typically H₂, H₂S, NH₃, and light hydrocarbons (C₁-C₄); one or more outlets for recovering product **346**, such as middle distillates naphtha and diesel products boiling in the temperature range including and below atmospheric gas oil range fractions (for instance in the temperature range of 36-370° C.); and one or more outlets for discharging bottoms **348** including hydrocarbons boiling above the atmospheric gas oil range (for instance 370° C.). In certain embodiments, the temperature cut point for bottoms **348** (and correspondingly the end point for the products **346**) is a range corresponding to the upper temperature limit of the desired gasoline, kerosene and/or diesel product boiling point ranges for downstream operations.

In operation of the once-through single reactor hydrocracking zone **330**, a feedstock stream **334** and a hydrogen stream **338** are charged to the reaction zone **332**. Hydrogen stream **338** is an effective quantity of hydrogen to support the requisite degree of hydrocracking, feed type, and other factors, and can be any combination including, recycle hydrogen **336** from optional gas separation subsystems (not shown) associated with reaction zone **332**, and/or derived from fractionator gas stream **344** and make-up hydrogen **302**, if necessary. In certain embodiments, a reaction zone can contain multiple catalyst beds and can receive one or more quench hydrogen streams between the beds (not shown).

The reaction effluent stream **340** contains converted, partially converted and unconverted hydrocarbons. Reaction effluent stream **340** is passed to fractionating zone **342** (optionally after one or more high pressure and low pressure separation stages to recover recycle hydrogen), generally to recover gas and liquid products and by-products **344**, **346**,

and separate a bottoms fraction **348**. This stream **348** is routed to the gas oil steam cracking zone **250** as described herein.

Gas stream **344**, typically containing H₂, H₂S, NH₃, and light hydrocarbons (C₁-C₄), is discharged and recovered and can be further processed. Effluent off-gases are passed to the olefins recovery train, the saturated gas plant as part of the other gases stream **156**, and/or directly to a fuel gas system. Liquefied petroleum gas can be recovered and routed to the mixed feed steam cracking zone, the olefins recovery train and/or the saturated gas plant. One or more cracked product streams **346** are discharged via appropriate outlets of the fractionator and can be further processed and/or blended in downstream refinery operations to produce gasoline, kerosene and/or diesel fuel, or other petrochemical products.

In certain embodiments (not shown), fractionating zone **342** can operate as a flash vessel to separate heavy components at a suitable cut point, for example, a range corresponding to the upper temperature range of the desired gasoline, kerosene and/or diesel products for downstream operations. In certain embodiments, a suitable cut point is in the range of 350 to 450° C., 360 to 450° C., 370 to 450° C., 350 to 400° C., 360 to 400° C., 370 to 400° C., 350 to 380° C., or 360 to 380° C. The stream above that cut point is routed to the gas oil steam cracking zone **250** as described herein.

For instance, a suitable once-through single reactor hydrocracking zone **330** can include, but is not limited to, systems based on technology commercially available from Honeywell UOP, US; Chevron Lummus Global LLC (CLG), US; Axens, IFP Group Technologies, FR; or Shell Global Solutions, US.

The reactor arrangement in the once-through single reactor hydrocracking zone **330** can contain one or more fixed-bed, ebullated-bed, slurry-bed, moving bed, continuous stirred tank (CSTR), or tubular reactors, which can be in parallel arrangement. The once-through single reactor hydrocracking zone **330** can operate in a mild hydrocracking mode of operation or a partial conversion mode of operation. Additional equipment, including exchangers, furnaces, feed pumps, quench pumps, and compressors to feed the reactor(s) and maintain proper operating conditions, are well known and are considered part of the once-through single reactor hydrocracking zone **330**. In addition, equipment, including pumps, compressors, high temperature separation vessels, low temperature separation vessels and the like to separate reaction products and provide hydrogen recycle within the once-through single reactor hydrocracking zone **330**, are well known and are considered part of the once-through single reactor hydrocracking zone **330**.

In certain embodiments, operating conditions for the reactor(s) in hydrocracking zone **330** using a once-through (single stage without recycle) configuration and operating in a mild hydrocracking mode include:

a reactor inlet temperature (° C.) in the range of from about 329-502, 329-460, 329-440, 372-502, 372-460, 372-440, 394-502, 394-460, 394-440 or 412-420;

a reactor outlet temperature (° C.) in the range of from about 338-516, 338-471, 338-450, 382-516, 382-471, 382-450, 400-516, 400-471, 400-450 or 422-430;

a start of run (SOR) reaction temperature, as a weighted average bed temperature (WABT), in the range of from about 310-475, 310-435, 310-415, 350-475, 350-435, 350-415, 370-475, 370-435, 370-415 or 390-397;

an end of run (EOR) reaction temperature, as a WABT, in the range of from about 338-516, 338-471, 338-450, 382-516, 382-471, 382-450, 400-516, 400-471, 400-450 or 422-430;

a reaction inlet pressure (barg) in the range of from about 108-161, 108-148, 108-141, 121-161, 121-148, 121-141, 128-161, 128-148, 128-141 or 131-137;

a reaction outlet pressure (barg) in the range of from about 100-150, 100-137, 100-130, 112-150, 112-137, 112-130, 118-150, 118-137 or 118-130;

a hydrogen partial pressure (barg) (outlet) in the range of from about 77-116, 77-106, 77-101, 87-116, 87-106, 87-101, 92-116, 92-106, 92-101 or 94-98;

a hydrogen treat gas feed rate (SLt/Lt) up to about 530, 510, 470 or 450, in certain embodiments from about 340-510, 340-470, 340-450, 382-510, 382-470, 382-450, 400-510, 400-470, 400-450 or 410-440;

a hydrogen quench gas feed rate (SLt/Lt) up to about 470, 427, 391 or 356, in certain embodiments from about 178-427, 178-214, 178-356, 214-321 or 178-391;

make-up hydrogen rate (SLt/Lt) up to about 225, 215, 200 or 190, in certain embodiments from about 143-215, 143-200, 143-190, 161-215, 161-200, 161-190, 170-215, 170-200 or 170-190; and

liquid hourly space velocity values (h⁻¹), on a fresh feed basis relative to the hydrocracking catalysts, are in the range of from about 0.1-10.0, 0.1-5.0, 0.1-2.0, 0.3-10.0, 0.3-5.0, 0.3-2.0, 0.4-10.0, 0.4-5.0 or 0.5-3.0.

Under the above conditions and catalyst selections, exemplary products from the once-through single reactor hydrocracking zone **330** operating in a mild hydrocracking mode of operation include 27-52, 27-48, 30-50 or 30-52 wt % of effluent (relative to the feed to the gas oil hydrotreating zone **330**) boiling at or below the atmospheric residue end boiling point, such as 370° C., including LPG, kerosene, naphtha, and atmospheric gas oil range components. The remaining bottoms fraction is the unconverted oil fraction, all or a portion of which can be effectively integrated as feed to the gas oil steam cracking zone **250** as described herein.

In certain embodiments, operating conditions for the reactor(s) in hydrocracking zone **330** using a once-through (single stage without recycle) configuration and operating in a partial conversion mode include:

a reactor inlet temperature (° C.) in the range of from about 340-502, 340-460, 340-440, 372-502, 372-460, 372-440, 394-502, 394-460, 394-440 or 412-420;

a reactor outlet temperature (° C.) in the range of from about 350-516, 350-471, 350-450, 382-516, 382-471, 382-450, 400-516, 400-471, 400-450 or 422-430;

a start of run (SOR) reaction temperature, as a weighted average bed temperature (WABT), in the range of from about 310-475, 310-435, 310-415, 350-475, 350-435, 350-415, 370-475, 370-435, 370-415 or 390-397;

an end of run (EOR) reaction temperature, as a WABT, in the range of from about 338-516, 338-471, 338-450, 382-516, 382-471, 382-450, 400-516, 400-471, 400-450 or 422-430;

a reaction inlet pressure (barg) in the range of from about 100-165, 100-150, 100-140, 120-165, 120-140, 130-165, 130-150, or 130-140;

a reaction outlet pressure (barg) in the range of from about 92-150, 92-137, 92-130, 112-150, 112-127, 112-130, 118-140, 118-130;

a hydrogen partial pressure (barg) (outlet) in the range of from about 80-120, 80-106, 80-101, 90-120, 90-106, 90-101, 100-120, or 100-115;

a hydrogen treat gas feed rate (SLt/Lt) up to about 677, 615, 587 or 573, in certain embodiments from about 503-615, 503-587, 503-573, 531-615, 531-587, 531-573, 545-615, 545-587, or 545-573;

a hydrogen quench gas feed rate (SLt/Lt) up to about 614, 558, 553 or 520, in certain embodiments from about 457-558, 457-533, 457-520, 482-558, 482-533, 482-520, 495-558, 495-533, or 495-520;

make-up hydrogen rate (SLt/Lt) up to about 305, 277, 264 or 252, in certain embodiments from about 204-277, 204-264, 204-252, 216-277, 216-264, 216-252, 228-277, 228-264, or 228-252; and

liquid hourly space velocity values (h^{-1}), on a fresh feed basis relative to the hydrocracking catalysts, are in the range of from about 0.1-10.0, 0.1-5.0, 0.1-2.0, 0.3-10.0, 0.3-5.0, 0.3-2.0, 0.4-10.0, 0.4-5.0, 0.4-2.0 or 0.5-3.0.

Under the above conditions and catalyst selections, exemplary products from the once-through single reactor hydrocracking zone **330** operating as a partial conversion hydrocracker include 48-82, 50-80, 48-75, or 50-75 wt % of effluent (relative to the feed to the gas oil hydrotreating zone **330**) boiling at or below the atmospheric residue end boiling point, such as 370° C., including LPG, kerosene, naphtha, and atmospheric gas oil range components. The remaining bottoms fraction is the unconverted oil fraction, all or a portion of which can be effectively integrated as feed to the gas oil steam cracking zone **250** as described herein.

FIG. **8** schematically depicts another embodiment of a series flow hydrocracking zone **350**, which operates as series-flow hydrocracking system with recycle to the first reactor zone, the second reactor zone, or both the first and second reactor zones. In general, series flow hydrocracking zone **350** includes a first reaction zone **352**, a second reaction zone **358** and a fractionating zone **342**.

First reaction zone **352** generally includes one or more inlets in fluid communication with a source of initial feedstock **334**, a source of hydrogen gas **338**, and in certain embodiments recycle stream **364a** comprising all or a portion of the fractionating zone **342** bottoms stream **348** and optionally a portion of fractionating zone **342** product stream **362**. One or more outlets of the first reaction zone **352** that discharge effluent stream **354** is in fluid communication with one or more inlets of the second reaction zone **358**. In certain embodiments, the effluents **354** are passed to the second reaction zone **358** without separation of any excess hydrogen and light gases. In optional embodiments, one or more high pressure and low pressure separation stages are provided between the first and second reaction zones **352**, **358** for recovery of recycle hydrogen (not shown).

The second reaction zone **358** generally includes one or more inlets in fluid communication with one or more outlets of the first reaction zone **352**, optionally a source of additional hydrogen gas **356**, and in certain embodiments a recycle stream **364b** comprising all or a portion of the fractionating zone **342** bottoms stream **348** and optionally a portion of fractionating zone **342** product stream **362**. One or more outlets of the second reaction zone **358** that discharge effluent stream **360** is in fluid communication with one or more inlets of the fractionating zone **342** (optionally having one or more high pressure and low pressure separation stages in between the second reaction zone **358** and the fractionating zone **342** for recovery of recycle hydrogen, not shown).

Fractionating zone **342** includes one or more outlets for discharging gases **344**, typically H_2 , H_2S , NH_3 , and light hydrocarbons (C_1-C_4); one or more outlets for recovering

product **346**, such as middle distillates naphtha and diesel products boiling in the temperature range including and below atmospheric gas oil range fractions (for instance in the temperature range of 36–370° C.); and one or more outlets for discharging bottoms **348** including hydrocarbons boiling above the atmospheric gas oil range (for instance about 370° C.), from which a bleed stream **368** is obtained in processes that do not operate with 100% recycle. In certain embodiments, the temperature cut point for bottoms **348** (and correspondingly the end point for the products **346**) is a range corresponding to the upper temperature limit of the desired gasoline, kerosene and/or diesel product boiling point ranges for downstream operations.

In operation of the series flow hydrocracking zone **350**, a feedstock stream **334** and a hydrogen stream **338** are charged to the first reaction zone **352**. Hydrogen stream **338** is an effective quantity of hydrogen to support the requisite degree of hydrocracking, feed type, and other factors, and can be any combination including, recycle hydrogen **336** from optional gas separation subsystems (not shown) associated with reaction zones **352** and **358**, and/or derived from fractionator gas stream **344** and make-up hydrogen **302**. In certain embodiments, a reaction zone can contain multiple catalyst beds and can receive one or more quench hydrogen streams between the beds (not shown).

First reaction zone **352** operates under effective conditions for production of reaction effluent stream **354** which is passed to the second reaction zone **358** (optionally after one or more high pressure and low pressure separation stages to recover recycle hydrogen), optionally along with an additional hydrogen stream **356**. Second reaction zone **358** operates under conditions effective for production of the reaction effluent stream **360**, which contains converted, partially converted and unconverted hydrocarbons.

The reaction effluent stream **360** is passed to fractionating zone **342**, generally to recover gas and liquid products and by-products **344**, **346**, and separate a bottoms fraction **348**. A portion of the bottoms fraction **348**, stream **368** is routed to the gas oil steam cracking zone **250** as described herein.

Gas stream **344**, typically containing H_2 , H_2S , NH_3 , and light hydrocarbons (C_1-C_4), is discharged and recovered and can be further processed. Effluent off-gases are passed to the olefins recovery train, the saturated gas plant as part of the other gases stream **156**, and/or directly to a fuel gas system. Liquefied petroleum gas can be recovered and routed to the mixed feed steam cracking zone, the olefins recovery train and/or the saturated gas plant. One or more cracked product streams **346** are discharged via appropriate outlets of the fractionator and can be further processed and/or blended in downstream refinery operations to produce gasoline, kerosene and/or diesel fuel, or other petrochemical products. In certain embodiments, a diesel fraction **362** derived from the one or more cracked product streams **346** can be integrated with the recycle streams to the reactors. This integration adds to the flexibility of the configuration between production of diesel fuel or petrochemicals from the product streams **346**.

In certain embodiments (not shown), fractionating zone **342** can operate as a flash vessel to separate heavy components at a suitable cut point, for example, a range corresponding to the upper temperature range of the desired gasoline, kerosene and/or diesel products for downstream operations. In certain embodiments, a suitable cut point is in the range of 350 to 450° C., 360 to 450° C., 370 to 450° C., 350 to 400° C., 360 to 400° C., 370 to 400° C., 350 to 380°

C., or 360 to 380° C. The stream above that cut point is routed to the gas oil steam cracking zone **250** as described herein.

All or a portion of the fractionator bottoms stream **348** from the reaction effluent is recycled to the first or second reaction zones **352** and/or **358** (streams **364a** and/or **364b**). In certain embodiments, a portion of the fractionator bottoms from the reaction effluent is removed as bleed stream **368**. Bleed stream **368** can be about 0-10 vol %, 1-10 vol %, 1-5 vol % or 1-3 vol % of the fractionator bottoms **348**. This stream **368** is routed to the gas oil steam cracking zone **250** as described herein.

Accordingly, all or a portion of the fractionator bottoms stream **348** is recycled to the second reaction zone **358** as stream **364b**, the first reaction zone **352** as stream **364a**, or both the first and second reaction zones **352** and **358**. For instance, stream **364a** recycled to zone **352** comprises 0 to 100 vol %, in certain embodiments 0 to about 80 vol %, and in further embodiments 0 to about 50 vol % of stream **348**, and stream **364b** recycled to zone **358** comprises 0 to 100 vol %, in certain embodiments 0 to about 80 vol %, and in further embodiments 0 to about 50 vol % of stream **348**. In certain embodiments, in which the recycle is at or approaches 100 vol %, recycle of the unconverted oil increases the yield of products suitable as feed to the mixed feed steam cracking zone **230**.

For instance, a suitable series flow hydrocracking zone **350** can include, but is not limited to, systems based on technology commercially available from Honeywell UOP, US; Chevron Lummus Global LLC (CLG), US; Axens, IFP Group Technologies, FR; or Shell Global Solutions, US.

The reactor arrangement in the series flow hydrocracking zone **350** can contain one or more fixed-bed, ebullated-bed, slurry-bed, moving bed, continuous stirred tank (CSTR), or tubular reactors, which can be in parallel arrangement. Additional equipment, including exchangers, furnaces, feed pumps, quench pumps, and compressors to feed the reactor(s) and maintain proper operating conditions, are well known and are considered part of the series flow hydrocracking zone **350**. In addition, equipment, including pumps, compressors, high temperature separation vessels, low temperature separation vessels and the like to separate reaction products and provide hydrogen recycle within the series flow hydrocracking zone **350**, are well known and are considered part of the series flow hydrocracking zone **350**.

In certain embodiments, operating conditions for the first reactor(s) in hydrocracking zone **350** using once-through series configuration operating in a partial conversion mode of operation include:

a reactor inlet temperature (° C.) in the range of from about 340-502, 340-460, 340-440, 372-502, 372-460, 372-440, 394-502, 394-460, 394-440 or 412-420;

a reactor outlet temperature (° C.) in the range of from about 350-516, 350-471, 350-450, 382-516, 382-471, 382-450, 400-516, 400-471, 400-450 or 422-430;

a start of run (SOR) reaction temperature, as a weighted average bed temperature (WABT), in the range of from about 310-475, 310-435, 310-415, 350-475, 350-435, 350-415, 370-475, 370-435, 370-415 or 390-397;

an end of run (EOR) reaction temperature, as a WABT, in the range of from about 338-516, 338-471, 338-450, 382-516, 382-471, 382-450, 400-516, 400-471, 400-450 or 422-430;

a reaction inlet pressure (barg) in the range of from about 100-165, 100-150, 100-140, 120-165, 120-140, 130-165, 130-150, or 130-140;

a reaction outlet pressure (barg) in the range of from about 92-150, 92-137, 92-130, 112-150, 112-127, 112-130, 118-140, 118-130;

a hydrogen partial pressure (barg) (outlet) in the range of from about 80-120, 80-106, 80-101, 90-120, 90-106, 90-101, 100-120, or 100-115;

a hydrogen treat gas feed rate (SLt/Lt) up to about 668, 607, 580 or 566, in certain embodiments from about 497-607, 497-580, 497-566, 525-607, 525-580, 525-566, 538-607, 538-580, or 538-566;

a hydrogen quench gas feed rate (SLt/Lt) up to about 819, 744, 711 or 694, in certain embodiments from about 609-744, 609-711, 609-694, 643-744, 643-711, 643-694, 660-744, 660-711, or 660-694;

make-up hydrogen rate (SLt/Lt) up to about 271, 246, 235 or 224, in certain embodiments from about 182-246, 182-235, 182-224, 192-246, 192-235, 192-224, 203-246, 203-235, or 203-224; and

liquid hourly space velocity values (h^{-1}), on a fresh feed basis relative to the hydrocracking catalysts, are in the range of from about 0.1-10.0, 0.1-5.0, 0.1-2.0, 0.3-10.0, 0.3-5.0, 0.3-2.0, 0.4-10.0, 0.4-5.0, 0.4-2.0 or 0.5-1.5.

In certain embodiments, operating conditions for the second reactor(s) in hydrocracking zone **350** using once-through series configuration operating in a partial conversion mode of operation include:

In certain embodiments, partial conversion hydrocracking using once-through configuration operating conditions include:

a reactor inlet temperature (° C.) in the range of from about 340-502, 340-460, 340-440, 372-502, 372-460, 372-440, 394-502, 394-460, 394-440 or 412-420;

a reactor outlet temperature (° C.) in the range of from about 350-516, 350-471, 350-450, 382-516, 382-471, 382-450, 400-516, 400-471, 400-450 or 422-430;

a start of run (SOR) reaction temperature, as a weighted average bed temperature (WABT), in the range of from about 310-475, 310-435, 310-415, 350-475, 350-435, 350-415, 370-475, 370-435, 370-415 or 390-397;

an end of run (EOR) reaction temperature, as a WABT, in the range of from about 338-516, 338-471, 338-450, 382-516, 382-471, 382-450, 400-516, 400-471, 400-450 or 422-430;

a reaction inlet pressure (barg) in the range of from about 90-150, 90-130, 90-140, 110-150, 110-130, 110-145, or 130-150;

a reaction outlet pressure (barg) in the range of from about 85-140, 85-127, 100-140, 112-130, 112-140, or 118-130;

hydrogen partial pressure (barg) (outlet) in the range of from about 80-130, 80-120, 80-101, 90-130, 90-120, 90-101, 100-130, or 100-115;

a hydrogen treat gas feed rate (SLt/Lt) up to about 890, 803, 767 or 748, in certain embodiments from about 657-803, 657-767, 657-748, 694-803, 694-767, 694-748, 712-803, 712-767, or 712-748;

a hydrogen quench gas feed rate (SLt/Lt) up to about 850, 764, 729 or 712, in certain embodiments from about 625-764, 625-729, 625-712, 660-764, 660-729, 660-712, 677-764, 677-729, or 677-712;

make-up hydrogen rate (SLt/Lt) up to about 372, 338, 323 or 309, in certain embodiments from about 250-338, 250-323, 250-309, 264-338, 264-323, 264-309, 279-338, 279-323, or 279-309; and

liquid hourly space velocity values (h^{-1}), on a fresh feed basis relative to the hydrocracking catalysts, are in the range of from about 0.1-10.0, 0.1-5.0, 0.1-2.0, 0.3-10.0, 0.3-5.0, 1.0-5.0, 2.0-4.0 or 1.0-3.0.

Under the above conditions and catalyst selections, exemplary products from the series-flow hydrocracking zone **350** operating as a partial conversion hydrocracker using once-through configuration include 48-82, 50-80, 48-75 or 50-75 wt % of effluent (relative to the feed to the hydrocracking zone **350** boiling at or below the atmospheric residue end boiling point, such as 370° C., including LPG, kerosene, naphtha, and atmospheric gas oil range components. The remaining bottoms fraction is the unconverted oil fraction, all or a portion of which can be effectively integrated as feed to the gas oil steam cracking zone **250** as described herein.

FIG. 9 schematically depicts another embodiment of an integrated hydrocracking unit operation, a two-stage with recycle hydrocracking zone **370**, which operates as two-stage hydrocracking system with recycle. In general, hydrocracking zone **370** includes a first reaction zone **372**, a second reaction zone **382** and a fractionating zone **342**.

First reaction zone **372** generally includes one or more inlets in fluid communication with a source of initial feedstock **334** and a source of hydrogen gas **338**. One or more outlets of the first reaction zone **372** that discharge effluent stream **374** are in fluid communication with one or more inlets of the fractionating zone **342** (optionally having one or more high pressure and low pressure separation stages therebetween for recovery of recycle hydrogen, not shown).

Fractionating zone **342** includes one or more outlets for discharging gases **344**, typically H₂S, NH₃, and light hydrocarbons (C₁-C₄); one or more outlets for recovering product **346**, such as naphtha and diesel products boiling in the temperature range including and below atmospheric gas oil range fractions (for instance in the temperature range of 36-370° C.); and one or more outlets for discharging bottoms **348** including hydrocarbons boiling above the atmospheric gas oil range (for instance about 370° C.), from which a bleed stream **368** is obtained in processes that do not operate with 100% recycle. In certain embodiments, the temperature cut point for bottoms **348** (and correspondingly the end point for the products **346**) is a range corresponding to the upper temperature limit of the desired gasoline, kerosene and/or diesel product boiling point ranges for downstream operations.

The fractionating zone **342** bottoms outlet is in fluid communication with the one or more inlets of the second reaction zone **382** for recycle stream **348a** derived from the bottoms stream **348**. Recycle stream **348a** can be all or a portion of the bottoms stream **348**. In certain optional embodiments (as indicated by dashed lines in FIG. 9), a portion **348b** is in fluid communication with one or more inlets of the first reaction zone **372**.

Second reaction zone **382** generally includes one or more inlets in fluid communication with the fractionating zone **342** bottoms outlet portion **348a** of bottoms **348**, and a source of hydrogen gas **384**. One or more outlets of the second reaction zone **382** that discharge effluent stream **386** are in fluid communication with one or more inlets of the fractionating zone **342** (optionally having one or more high pressure and low pressure separation stages therebetween for recovery of recycle hydrogen, not shown).

In operation of the two-stage hydrocracking zone **370**, a feedstock stream **334** and a hydrogen stream **338** are charged to the first reaction zone **372**. Hydrogen stream **338** is an effective quantity of hydrogen to support the requisite degree of hydrocracking, feed type, and other factors, and can be any combination including, recycle hydrogen **336** from optional gas separation subsystems (not shown) associated with reaction zones **372** and **382**, and/or derived from fractionator gas stream **344** and make-up hydrogen **302**. In

certain embodiments, a reaction zone can contain multiple catalyst beds and can receive one or more quench hydrogen streams between the beds (not shown).

First reaction zone **372** operates under effective conditions for production of reaction effluent stream **374** which is passed to the fractionating zone **342** (optionally after one or more high pressure and low pressure separation stages to recover recycle hydrogen) generally to recover gas and liquid products and by-products, and separate a bottoms fraction.

Gas stream **344**, typically containing H₂, H₂S, NH₃, and light hydrocarbons (C₁-C₄), is discharged and recovered and can be further processed. Effluent off-gases are passed to the olefins recovery train, the saturated gas plant as part of the other gases stream **156**, and/or directly to a fuel gas system. Liquefied petroleum gas can be recovered and routed to the mixed feed steam cracking zone, the olefins recovery train and/or the saturated gas plant. One or more cracked product streams **346** are discharged via appropriate outlets of the fractionator and can be further processed and/or blended in downstream refinery operations to produce gasoline, kerosene and/or diesel fuel, or other petrochemical products. In certain embodiments, a diesel fraction **376** derived from the one or more cracked product streams **346** can be integrated with the feed to the second stage reactor **382**. This integration adds to the flexibility of the configuration between production of diesel fuel or petrochemicals from the product streams **346**.

In certain embodiments (not shown), fractionating zone **342** can operate as a flash vessel to separate heavy components at a suitable cut point, for example, a range corresponding to the upper temperature range of the desired gasoline, kerosene and/or diesel products for downstream operations. In certain embodiments, a suitable cut point is in the range of 350 to 450° C., 360 to 450° C., 370 to 450° C., 350 to 400° C., 360 to 400° C., 370 to 400° C., 350 to 380° C., or 360 to 380° C. The stream above that cut point is routed to the gas oil steam cracking zone **250** as described herein.

All or a portion of the fractionator bottoms stream **348** from the reaction effluent is passed to the second reaction zone **382** as stream **348a**. In certain embodiments, all or a portion of the bottoms stream **348** is recycled to the second reaction zone **382** as stream **348a**, the first reaction zone **372** as stream **348b**, or both the first and second reaction zones **372** and **382**. For instance, stream **348b** which is recycled to zone **372** comprises 0 to 100 vol %, 0 to about 80 vol %, or 0 to about 50 vol % of stream **348**, and stream **348a** which is recycled to zone **382** comprises 0 to 100 vol %, 0 to about 80 vol %, or 0 to about 50 vol % of stream **348**. In certain embodiments, in which the recycle is at or approaches 100 vol %, recycle of the unconverted oil increases the yield of products suitable as feed to the mixed feed steam cracking zone **230**.

In certain embodiments, a portion of the fractionator bottoms from the reaction effluent is removed as bleed stream **368**. Bleed stream **368** can be about 0-10 vol %, 1-10 vol %, 1-5 vol % or 1-3 vol % of the fractionator bottoms **348**.

Second reaction zone **382** operates under conditions effective for production of the reaction effluent stream **386**, which contains converted, partially converted and unconverted hydrocarbons. The second stage the reaction effluent stream **386** is passed to the fractionating zone **342**, optionally through one or more gas separators to recovery recycle hydrogen and remove certain light gases

For instance, a suitable two-stage hydrocracking zone **370** can include, but is not limited to, systems based on technology commercially available from Honeywell UOP, US; Chevron Lummus Global LLC (CLG), US; Axens, IFP Group Technologies, FR; or Shell Global Solutions, US.

The reactor arrangement in the two-stage with recycle hydrocracking zone **370** can contain one or more fixed-bed, ebullated-bed, slurry-bed, moving bed, continuous stirred tank (CSTR), or tubular reactors, which can be in parallel arrangement. Additional equipment, including exchangers, furnaces, feed pumps, quench pumps, and compressors to feed the reactor(s) and maintain proper operating conditions, are well known and are considered part of the two-stage hydrocracking zone **370**. In addition, equipment, including pumps, compressors, high temperature separation vessels, low temperature separation vessels and the like to separate reaction products and provide hydrogen recycle within the two-stage hydrocracking zone **370**, are well known and are considered part of the two-stage hydrocracking zone **370**.

In certain embodiments, operating conditions for the first stage reactor(s) in hydrocracking zone **370** using a two-stage with recycle configuration operating in a full conversion mode of operation include:

a reactor inlet temperature ($^{\circ}$ C.) in the range of from about 340-502, 340-460, 340-440, 372-502, 372-460, 372-440, 394-502, 394-460, 394-440 or 412-420;

a reactor outlet temperature ($^{\circ}$ C.) in the range of from about 350-516, 350-471, 350-450, 382-516, 382-471, 382-450, 400-516, 400-471, 400-450 or 422-430;

a start of run (SOR) reaction temperature, as a weighted average bed temperature (WABT), in the range of from about 310-475, 310-435, 310-415, 350-475, 350-435, 350-415, 370-475, 370-435, 370-415 or 390-397;

an end of run (EOR) reaction temperature, as a WABT, in the range of from about 338-516, 338-471, 338-450, 382-516, 382-471, 382-450, 400-516, 400-471, 400-450 or 422-430;

a reaction inlet pressure (barg) in the range of from about 100-180, 100-160, 100-141, 121-180, 121-160, 121-141, 128-180, 128-160, 128-141 or 131-180;

a reaction outlet pressure (barg) in the range of from about 90-170, 90-137, 90-130, 112-170, 112-137, 112-130, 118-150, 118-137 or 118-170;

a hydrogen partial pressure (barg) (outlet) in the range of from about 90-137, 90-106, 90-120, 100-137, 100-106, or 100-120;

a hydrogen treat gas feed rate (SLt/Lt) up to about 1050, 940, 898 or 876, in certain embodiments from about 769-940, 769-898, 769-876, 812-940, 812-898, 812-876, 834-940, 834-898, or 834-876;

a hydrogen quench gas feed rate (SLt/Lt) up to about 1100, 980, 935 or 913, in certain embodiments from about 801-980, 801-935, 801-913, 846-980, 846-935, 846-913, 868-980, 868-935, or 868-913;

make-up hydrogen rate (SLt/Lt) up to about 564, 512, 490 or 468, in certain embodiments from about 378-512, 378-490, 378-468, 401-512, 401-490, 401-468, 423-512, 423-490, or 423-468; and

liquid hourly space velocity values (h^{-1}), on a fresh feed basis relative to the hydrocracking catalysts, are in the range of from about 0.1-10.0, 0.1-5.0, 0.1-2.0, 0.3-10.0, 0.3-5.0, 0.3-2.0, 0.4-10.0, 0.4-5.0, 0.4-2.0 or 0.5-1.5.

In certain embodiments, operating conditions for the second stage reactor(s) in hydrocracking zone **370** using a two-stage with recycle configuration operating in a full conversion mode of operation include:

In certain embodiments, operating conditions for the reactor(s) in the first stage reaction zone of the two-stage hydrocracking zone **370** include:

a reactor inlet temperature ($^{\circ}$ C.) in the range of from about 340-502, 340-460, 340-440, 372-502, 372-460, 372-440, 394-502, 394-460, 394-440 or 412-420;

a reactor outlet temperature ($^{\circ}$ C.) in the range of from about 350-516, 350-471, 350-450, 382-516, 382-471, 382-450, 400-516, 400-471, 400-450 or 422-430;

a start of run (SOR) reaction temperature, as a weighted average bed temperature (WABT), in the range of from about 310-475, 310-435, 310-415, 350-475, 350-435, 350-415, 370-475, 370-435, 370-415 or 390-397;

an end of run (EOR) reaction temperature, as a WABT, in the range of from about 338-516, 338-471, 338-450, 382-516, 382-471, 382-450, 400-516, 400-471, 400-450 or 422-430;

a reaction inlet pressure (barg) in the range of from about 80-145, 80-100, 80-131, 80-120, 120-145, 100-145, or 130-145;

a reaction outlet pressure (barg) in the range of from about 75-137, 75-130, 90-130, 100-137, 100-122, or 112-137;

a hydrogen partial pressure (barg) (outlet) in the range of from about 90-145, 90-106, 90-120, 100-145, 100-106, or 100-120;

a hydrogen treat gas feed rate (SLt/Lt) up to about 910, 823, 785 or 767, in certain embodiments from about 673-823, 673-785, 673-767, 711-823, 711-785, 711-767, 729-823, 729-785, or 729-767;

a hydrogen quench gas feed rate (SLt/Lt) up to about 980, 882, 842 or 822, in certain embodiments from about 721-882, 721-842, 721-822, 761-882, 761-842, 761-822, 781-882, 781-842, or 781-822;

make-up hydrogen rate (SLt/Lt) up to about 451, 410, 392 or 374, in certain embodiments from about 303-410, 303-392, 303-374, 321-410, 321-392, 321-374, 338-410, 338-392, or 338-374; and

liquid hourly space velocity values (h^{-1}), on a fresh feed basis relative to the hydrocracking catalysts, are in the range of from about 0.1-10.0, 0.1-5.0, 0.1-2.0, 0.3-10.0, 0.3-5.0, 1.0-5.0, 2.0-4.0 or 1.0-3.0.

Under the above conditions and catalyst selections, exemplary products from the hydrocracking zone **370** operating as a two-stage hydrocracker (with recycle) in a full conversion mode include 78-99, 78-90, 78-85, 80-90 or 80-99 wt % of effluent (relative to the feed to the hydrocracking zone **370**) boiling at or below the atmospheric residue end boiling point, such as 370° C., including LPG, kerosene, naphtha, and atmospheric gas oil range components. The remaining bottoms fraction is the unconverted oil fraction, all or a portion of which can be effectively integrated as feed to the gas oil steam cracking zone **250** as described herein.

In certain embodiments, 0-100 wt % of the vacuum residue stream **168** can be processed in a residue treatment center **800** (shown in dashed lines as an optional embodiment). In additional embodiments, 0-100 wt % of the pyrolysis oil from the steam cracker complex can be routed to the residue treatment center **800**. The residue treatment center **800** can include, but is not limited to, one or more of: a catalytic hydrogen addition process, such as a residue hydrocracking system; a thermal coking process, such as a delayed coker; and/or a solvent deasphalting process. In certain embodiments, the residue treatment center **800** produces one or more of a distillate fraction **808**, a heavy fraction **806**, and/or a bottoms fraction **804**. The distillate fraction **808** can include, for instance, one or more middle distillate streams boiling in the temperature range including

and below atmospheric gas oil range fractions (for instance in the temperature range of 36-370° C.), or including and below medium atmospheric gas oil range fractions. Note that when the residue treatment center **800** is solvent deasphalting, a distillate fraction **808** is not produced. Portions of the distillate fraction **808** can be used as feed to the mixed feed steam cracking zone **230**, feed to one or more of the integrated hydroprocessing zones, and/or used for production of fuel components. All or a portion of the heavy fraction **806** can include, for instance, one or more streams of treated heavy range hydrocarbons boiling above the atmospheric gas oil range (for instance 370° C.), or above the medium atmospheric gas oil range; or deasphalted oil in a solvent deasphalting unit. Portions of the heavy fraction **806** can be used as feed to the gas oil steam cracking zone **250**, feed to one or more of the integrated hydroprocessing zones, recovered as unconverted oil product, used for lube oil production in a base oil production zone, and/or incorporated in a fuel oil pool. The bottoms fraction **804** can include, for instance, pitch in a residue hydrocracking system, petroleum coke in a delayed coker, or asphalt in a solvent deasphalting unit).

Embodiments of systems and processes incorporating certain vacuum residue hydroprocessing zones are disclosed in U.S. patent application Ser. No. 15/817,133 filed on Nov. 17, 2017, entitled "Process and System for Conversion of Crude Oil to Petrochemicals and Fuel Products Integrating Vacuum Residue Hydroprocessing," and U.S. patent application Ser. No. 15/817,136 filed on Nov. 17, 2017, entitled "Process and System for Conversion of Crude Oil to Petrochemicals and Fuel Products Integrating Vacuum Residue Conditioning and Base Oil Production," which are commonly owned and are incorporated by reference herein in their entireties. Embodiments of systems and processes incorporating solvent deasphalting are disclosed in U.S. patent application Ser. No. 15/817,140 filed on Nov. 17, 2017, entitled "Process and System for Conversion of Crude Oil to Petrochemicals and Fuel Products Integrating Solvent Deasphalting of Vacuum Residue," which is commonly owned and is incorporated by reference herein in its entirety. Embodiments of systems and processes incorporating thermal coking are disclosed in U.S. patent application Ser. No. 15/817,143 filed on Nov. 17, 2017, entitled "Process and System for Conversion of Crude Oil to Petrochemicals and Fuel Products Integrating Delayed Coking of Vacuum Residue," which is commonly owned and is incorporated by reference herein in its entirety.

The mixed feed steam cracking zone **230**, which operates as a high severity or low severity thermal cracking process, generally converts LPG, naphtha and heavier hydrocarbons primarily into a mixed product stream **232** containing mixed C1-C4 paraffins and olefins. In certain embodiments, the mixed feed steam cracking zone **230** processes straight-run liquids from the crude unit, ethane and/or propane (from outside battery limits and/or recycled) and various recycle streams from chemical production and recovery areas within the integrated process and system. A suitable mixed feed steam cracking zone **230** can include, but is not limited to, systems based on technology commercially available from Linde AG, DE; TechnipFMC plc, UK; Chicago Bridge & Iron Company N.V. (CB&I), NL; or KBR, Inc, US.

For instance, plural feeds to the mixed feed steam cracking zone **230** include: light ends **152**, light naphtha **138** and heavy naphtha **140** (or a full range straight run naphtha **136** as shown in other embodiments) from the crude complex **100**; a LPG stream **634** from a transalkylation zone **630**; a recycle stream **282** from the methylacetylene/propadiene

(MAPD) saturation and propylene recovery zone **280** described below; C4 raffinate **524** from the 1-butene recovery zone **520** described below; wild naphtha **184** from the diesel hydrotreating zone **180** described above (in certain embodiments via the crude complex); wild naphtha **326** from the gas oil hydrocracking zone **320** described above (in certain embodiments via the crude complex); a raffinate stream **646** from the aromatics extraction zone **620** described below; in certain embodiments a C5 cut derived from the pyrolysis gasoline described below; and optionally, propane stream **228** (from outside battery limits). In certain embodiments, the mixed feed steam cracking zone **230** can accept alternate feeds from other sources, for instance, other naphtha range feeds that may become available from outside of the battery limits.

The products from the mixed feed steam cracking zone **230** include: a quenched cracked gas stream **232** containing mixed C1-C4 paraffins and olefins that is routed to the olefins recovery zone **270**; a raw pyrolysis gasoline stream **234** that is routed to a py-gas hydrotreating zone **600** to produce hydrotreated pyrolysis gasoline **604** as feed to the aromatics extraction zone **620**, and C5s **606**; and a pyrolysis fuel oil stream **236**.

The mixed feed steam cracking zone **230** operates under parameters effective to crack the feed into desired products including ethylene, propylene, butadiene, and mixed butenes. Pyrolysis gasoline and pyrolysis oil are also recovered. In certain embodiments, the steam cracking furnace(s) are operated at conditions effective to produce an effluent having a propylene-to-ethylene weight ratio of from about 0.3-0.8, 0.3-0.6, 0.4-0.8 or 0.4-0.6.

The mixed feed steam cracking zone **230** generally comprises one or more trains of furnaces. For instance, a typical arrangement includes reactors that can operate based on well-known steam pyrolysis methods, that is, charging the thermal cracking feed to a convection section in the presence of steam to raise the temperature of the feedstock, and passing the heated feed to the pyrolysis reactor containing furnace tubes for cracking. In the convection section, the mixture is heated to a predetermined temperature, for example, using one or more waste heat streams or other suitable heating arrangement.

The feed mixture is heated to a high temperature in a convection section and material with a boiling point below a predetermined temperature is vaporized. The heated mixture (in certain embodiments along with additional steam) is passed to the pyrolysis section operating at a further elevated temperature for short residence times, such as 1-2 seconds or less, effectuating pyrolysis to produce a mixed product stream. In certain embodiments separate convection and radiant sections are used for different incoming feeds to the mixed feed steam cracking zone **230** with conditions in each optimized for the particular feed.

In certain embodiments, steam cracking in the mixed feed steam cracking zone **230** is carried out using the following conditions: a temperature (° C.) in the convection section in the range of about 400-600, 400-550, 450-600 or 500-600; a pressure (barg) in the convection section in the range of about 4.3-4.8, 4.3-4.45, 4.3-4.6, 4.45-4.8, 4.45-4.6 or 4.6-4.8; a temperature (° C.) in the pyrolysis section in the range of about 700-950, 700-900, 700-850, 750-950, 750-900 or 750-850; a pressure (barg) in the pyrolysis section in the range of about 1.0-1.4, 1.0-1.25, 1.25-1.4, 1.0-1.15, 1.15-1.4 or 1.15-1.25; a steam-to-hydrocarbon ratio in the in the convection section in the range of about 0.3:1-2:1, 0.3:1-1.5:1, 0.5:1-2:1, 0.5:1-1.5:1, 0.7:1-2:1, 0.7:1-1.5:1, 1:1-2:1 or 1:1-1.5:1; and a residence time (seconds) in the pyrolysis

section in the range of about 0.05-1.2, 0.05-1, 0.1-1.2, 0.1-1, 0.2-1.2, 0.2-1, 0.5-1.2 or 0.5-1.

In operation of the mixed feed steam cracking zone **230**, effluent from the cracking furnaces is quenched, for instance, using transfer line exchangers, and passed to a quench tower. The light products, quenched cracked gas stream **232**, are routed to the olefins recovery zone **270**. Heavier products are separated in a hot distillation section. A raw pyrolysis gasoline stream is recovered in the quench system. Pyrolysis oil **236** is separated at a primary fractionator tower before the quench tower.

In operation of one embodiment of the mixed feed steam cracking zone **230**, the feedstocks are mixed with dilution steam to reduce hydrocarbon partial pressure and then are preheated. The preheated feeds are fed to tubular reactors mounted in the radiant sections of the cracking furnaces. The hydrocarbons undergo free-radical pyrolysis reactions to form light olefins ethylene and propylene, and other by-products. In certain embodiments, dedicated cracking furnaces are provided with cracking tube geometries optimized for each of the main feedstock types, including ethane, propane, and butanes/naphtha. Less valuable hydrocarbons, such as ethane, propane, C4 raffinate, and aromatics raffinate, produced within the integrated system and process, are recycled to extinction in the mixed feed steam cracking zone **230**.

In certain embodiments, cracked gas from the furnaces is cooled in transfer line exchangers (quench coolers), for example, producing 1800 psig steam suitable as dilution steam. Quenched cracked gas enters a primary fractionator associated with the mixed feed steam cracking zone **230** for removal of pyrolysis fuel oil bottoms from lighter components. The primary fractionator enables efficient recovery of pyrolysis fuel oil. Pyrolysis fuel oil is stripped with steam in a fuel oil stripper to control product vapor pressure, and cooled. In addition, secondary quench can be carried out by direct injection of pyrolysis fuel oil as quench oil into liquid furnace effluents. The stripped and cooled pyrolysis fuel oil can be sent to a fuel oil pool or product storage. The primary fractionator overhead is sent to a quench water tower; condensed dilution steam for process water treating, and raw pyrolysis gasoline, are recovered. Quench water tower overhead is sent to the olefins recovery zone **270**, particularly the first compression stage. Raw pyrolysis gasoline is sent to a gasoline stabilizer to remove any light ends and to control vapor pressure in downstream pyrolysis gasoline processing. A closed-loop dilution steam/process water system is enabled, in which dilution steam is generated using heat recovery from the primary fractionator quench pumparound loops. The primary fractionator enables efficient recovery of pyrolysis fuel oil due to energy integration and pyrolysis fuel oil content in the light fraction stream.

The gas oil steam cracking zone **250** is operated under conditions effective for conversion its feeds into light olefins, pyrolysis gasoline and pyrolysis oil. As described herein feeds to the gas oil steam cracking zone **250** include vacuum gas oil range products from the vacuum gas oil hydroprocessing zone, such as unconverted oil **324** from the VGO hydrocracking zone **320**, and in certain embodiments all or a portion of the third middle distillate stream **126**, for instance, in the atmospheric gas oil range. In certain embodiments, the gas oil steam cracking zone **250** can accept alternate feeds from other sources, for instance, other gas oil range feeds that may become available from outside of the battery limits. Products from the gas oil steam cracking zone **250** include a quenched cracked gas stream **252** containing mixed C1-C4 paraffins and olefins that is routed to the

olefins recovery zone **270**, a raw pyrolysis gasoline stream **254** that is routed to a py-gas hydrotreating zone **600** to provide additional feed **604** to the aromatics extraction zone **620**, and a pyrolysis fuel oil stream **256**.

The gas oil steam cracking zone **250** operates under parameters effective to crack the feed into desired products including ethylene, propylene, butadiene, and mixed butenes. Pyrolysis gasoline and pyrolysis oil are also recovered. In certain embodiments, the steam cracking furnace(s) in the gas oil steam cracking zone **250** are operated at conditions effective to produce an effluent having a propylene-to-ethylene weight ratio of from about 0.3-0.8, 0.3-0.6, 0.4-0.8 or 0.4-0.6.

In one embodiment of the gas oil steam cracking zone **250**, the feedstock is preheated and mixed with a dilution steam to reduce hydrocarbon partial pressure in a convection section. The steam-hydrocarbon mixture is heated further and fed to tubular reactors mounted in the radiant sections of the cracking furnaces. The hydrocarbons undergo free-radical pyrolysis reactions to form light olefins, ethylene and propylene, and other by-products.

In certain embodiments, steam cracking in the gas oil steam cracking zone **250** is carried out using the following conditions: a temperature ($^{\circ}$ C.) in the convection section in the range of about 300-450 or 300-400; a pressure (barg) in the convection section in the range of about 7.2-9.7, 7.2-8.5, 7.2-7.7, 7.7-8.5, 7.7-9.7 or 8.5-9.7; a temperature ($^{\circ}$ C.) in the pyrolysis section in the range of about 700-850, 700-800, 700-820, 750-850, 750-800 or 750-820; a pressure (barg) in the pyrolysis section in the range of about 0.9-1.2, 0.9-1.4, 0.9-1.6, 1.2-1.4, 1.2-1.6 or 1.4-1.6; a steam-to-hydrocarbon ratio in the in the convection section in the range of about 0.75:1-2:1, 0.75:1-1.5:1, 0.85:1-2:1, 0.9:1-1.5:1, 1:1-2:1 or 1:1-1.5:1; and a residence time (seconds) in the pyrolysis section in the range of about 0.02-1, 0.02-0.08, 0.02-0.5, 0.1-1, 0.1-0.5, 0.2-0.5, 0.2-1, or 0.5-1.

In certain embodiments, cracked gas from the gas oil steam cracking zone **250** furnaces is quenched in transfer line exchangers by producing, for instance, 1800 psig steam. Quenched gases are stripped with steam in a primary fractionator. Lighter gases are recovered as the overhead product; a side-draw stream contains pyrolysis fuel oil. The primary fractionator bottoms product is pyrolysis tar, which is cooled and sent to product storage. Pyrolysis fuel oil from the primary fractionator is stripped with steam in the pyrolysis fuel oil stripper, which separates pyrolysis gasoline as the overhead and pyrolysis fuel oil as the bottoms product. Gasoline in the primary fractionator overhead is condensed and combined with gasoline from the pyrolysis fuel oil stripper before being sent to a gasoline stabilizer. The gasoline stabilizer removes light products in the overhead, while the stabilizer bottoms are sent to the py-gas hydrotreater. C4 and lighter gases in the primary fractionator overhead are compressed, for instance, in two stages of compression, before entering an absorber, depropanizer and debutanizer.

Compression of C4 and lighter gases from both the mixed feed steam cracking zone **230** and the gas oil steam cracking zone **250** can be carried out in certain embodiments in a common step, to reduce capital and operating costs associated with compression, thereby increasing efficiencies in the integrated process herein. Accordingly, both the C4 and lighter gas stream **232** and the C4 and lighter gas stream **252** are passed to the olefins recovery zone **270**.

In certain embodiments, cracked gas from the furnaces of both the mixed feed steam cracking zone **230** and the gas oil steam cracking zone **250** are subjected to common steps for

quenching, recovery of pyrolysis gasoline, recovery of pyrolysis oil, and recovery of C4 and lighter gases. For instance, in one embodiment, the cracked gas from the furnaces of both steam cracking zones are combined cooled in transfer line exchangers (quench coolers), for example, producing 1800 psig steam suitable as dilution steam. Quenched cracked gas enters a primary fractionator for removal of pyrolysis fuel oil bottoms from lighter components. The primary fractionator enables efficient recovery of pyrolysis fuel oil. Pyrolysis fuel oil is stripped with steam in a fuel oil stripper to control product vapor pressure and cooled. In addition, secondary quench can be carried out by direct injection of pyrolysis fuel oil as quench oil into liquid furnace effluents. The stripped and cooled pyrolysis fuel oil can be sent to a fuel oil pool or product storage. The primary fractionator overhead is sent to a quench water tower; condensed dilution steam for process water treating, and raw pyrolysis gasoline, are recovered. Quench water tower overhead is sent to the olefins recovery zone 270, particularly the first compression stage. Raw pyrolysis gasoline is sent to a gasoline stabilizer to remove any light ends and to control vapor pressure in downstream pyrolysis gasoline processing. A closed-loop dilution steam/process water system is enabled, in which dilution steam is generated using heat recovery from the primary fractionator quench pumparound loops. The primary fractionator enables efficient recovery of pyrolysis fuel oil due to energy integration and pyrolysis fuel oil content in the light fraction stream.

The mixed product stream 232 effluent from the mixed feed steam cracking zone 230 and the mixed product stream 252 effluent from the gas oil steam cracking zone 250 are shown as combined streams 220. Stream 220 is routed to an olefins recovery zone 270. For instance, light products from the quenching step, C4-, H₂ and H₂S, are contained in the mixed product stream 220 that is routed to the olefins recovery zone 270. Products include: hydrogen 210 that is used for recycle and/or passed to users; fuel gas 208 that is passed to a fuel gas system; ethane 272 that is recycled to the mixed feed steam cracking zone 230; ethylene 202 that is recovered as product; a mixed C3 stream 286 that is passed to a methyl acetylene/propadiene saturation and propylene recovery zone 280; and a mixed C4 stream 206 that is passed to a butadiene extraction zone 500.

The olefins recovery zone 270 operates to produce on-specification light olefin (ethylene and propylene) products from the mixed product stream 220. For instance, cooled gas intermediate products from the steam cracker is fed to a cracked gas compressor, caustic wash zone, and one or more separation trains for separating products by distillation. In certain embodiments two trains are provided. The distillation train includes a cold distillation section, wherein lighter products such as methane, hydrogen, ethylene, and ethane are separated in a cryogenic distillation/separation operation. The mixed C2 stream from the steam cracker contains acetylenes that are hydrogenated to produce ethylene in an acetylene selective hydrogenation unit. This system can also include ethylene, propane and/or propylene refrigeration facilities to enable cryogenic distillation.

In one embodiment, mixed product stream 232 effluent from the mixed feed steam cracking zone 230 and the mixed product stream 252 effluent from the gas oil steam cracking zone 250 are passed through three to five stages of compression. Acid gases are removed with caustic in a caustic wash tower. After an additional stage of compression and drying, light cracked gases are chilled and routed to a depropanizer. In certain embodiments light cracked gases are chilled with a cascaded two-level refrigeration system

(propylene, mixed binary refrigerant) for cryogenic separation. A front-end depropanizer optimizes the chilling train and demethanizer loading. The depropanizer separates C3 and lighter cracked gases as an overhead stream, with C4s and heavier hydrocarbons as the bottoms stream. The depropanizer bottoms are routed to the debutanizer, which recovers a crude C4s stream 206 and any trace pyrolysis gasoline, which can be routed to the py-gas hydrotreating zone 600 (not shown).

The depropanizer overhead passes through a series of acetylene conversion reactors, and is then fed to the demethanizer chilling train, which separates a hydrogen-rich product via a hydrogen purification system, such as pressure swing adsorption. Front-end acetylene hydrogenation is implemented to optimize temperature control, minimize green oil formation and simplify ethylene product recovery by eliminating a C2 splitter pasteurization section that is otherwise typically included in product recovery. In addition, hydrogen purification via pressure swing adsorption eliminates the need for a methanation reactor that is otherwise typically included in product recovery.

The demethanizer recovers methane in the overhead for fuel gas, and C2 and heavier gases in the demethanizer bottoms are routed to the deethanizer. The deethanizer separates ethane and ethylene overhead which feeds a C2 splitter. The C2 splitter recovers ethylene product 202, in certain embodiments polymer-grade ethylene product, in the overhead. Ethane 272 from the C2 splitter bottoms is recycled to the mixed feed steam cracking zone 230. Deethanizer bottoms contain C3s from which propylene product 204, in certain embodiments polymer-grade propylene product, is recovered as the overhead of a C3 splitter, with propane 282 from the C3 splitter bottoms recycled to the mixed feed steam cracking zone 230.

A methyl acetylene/propadiene (MAPD) saturation and propylene recovery zone 280 is provided for selective hydrogenation to convert methyl acetylene/propadiene, and to recover propylene from a mixed C3 stream 286 from the olefins recovery zone 270. The mixed C3 286 from the olefins recovery zone 270 contains a sizeable quantity of propadiene and propylene. The methyl acetylene/propadiene saturation and propylene recovery zone 280 enables production of propylene 204, which can be polymer-grade propylene in certain embodiments.

The methyl acetylene/propadiene saturation and propylene recovery zone 280 receives hydrogen 284 and mixed C3 286 from the olefins recovery zone 270. Products from the methyl acetylene/propadiene saturation and propylene recovery zone 280 are propylene 204 which is recovered, and the recycle C3 stream 282 that is routed to the steam cracking zone 230. In certain embodiments, hydrogen 284 to saturate methyl acetylene and propadiene is derived from hydrogen 210 obtained from the olefins recovery zone 270.

A stream 206 containing a mixture of C4s, known as crude C4s, from the olefins recovery zone 270, is routed to a butadiene extraction zone 500 to recover a high purity 1,3-butadiene product 502 from the mixed crude C4s. In certain embodiments (not shown), a step of hydrogenation of the mixed C4 before the butadiene extraction zone 500 can be integrated to remove acetylenic compounds, for instance, with a suitable catalytic hydrogenation process using a fixed bed reactor. 1,3-butadiene 502 is recovered from the hydrogenated mixed C4 stream by extractive distillation using, for instance, n-methyl-pyrrolidone (NMP) or dimethylformamide (DMF) as solvent. The butadiene

extraction zone **500** also produces a raffinate stream **504** containing butane/butene, which is passed to a methyl tertiary butyl ether zone **510**.

In one embodiment, in operation of the butadiene extraction zone **500**, the stream **206** is preheated and vaporized into a first extractive distillation column, for instance having two sections. NMP or DMF solvent separates the 1,3-butadiene from the other C4 components contained in stream **504**. Rich solvent is flashed with vapor to a second extractive distillation column that produces a high purity 1,3-butadiene stream as an overhead product. Liquid solvent from the flash and the second distillation column bottoms are routed to a primary solvent recovery column. Bottoms liquid is circulated back to the extractor and overhead liquid is passed to a secondary solvent recovery or solvent polishing column. Vapor overhead from the recovery columns combines with recycle butadiene product into the bottom of the extractor to increase concentration of 1,3-butadiene. The 1,3-butadiene product **502** can be water washed to remove any trace solvent. In certain embodiments, the product purity (wt %) is 97-99.8, 97.5-99.7 or 98-99.6 of 1,3-butadiene; and 94-99, 94.5-98.5 or 95-98 of the 1,3-butadiene content (wt %) of the feed is recovered. In addition to the solvent such as DMF, additive chemicals are blended with the solvent to enhance butadiene recovery. In addition, the extractive distillation column and primary solvent recovery columns are reboiled using high pressure steam (for instance, 600 psig) and circulating hot oil from the aromatics extraction zone **620** as heat exchange fluid.

A methyl tertiary butyl ether zone **510** is integrated to produce methyl tertiary butyl ether **514** and a second C4 raffinate **516** from the first C4 raffinate stream **504**. In certain embodiments C4 Raffinate 1 **504** is subjected to selective hydrogenation to selectively hydrogenate any remaining dienes and prior to reacting isobutenes with methanol to produce methyl tertiary butyl ether.

Purity specifications for recovery of a 1-butene product stream **522** necessitate that the level of isobutylene in the second C4 raffinate **516** be reduced. In general, the first C4 raffinate stream **504** containing mixed butanes and butenes, and including isobutylene, is passed to the methyl tertiary butyl ether zone **510**. Methanol **512** is also added, which reacts with isobutylene and produces methyl tertiary butyl ether **514**. For instance, methyl tertiary butyl ether product and methanol are separated in a series of fractionators, and routed to a second reaction stage. Methanol is removed with water wash and a final fractionation stage. Recovered methanol is recycled to the fixed bed downflow dehydrogenation reactors. In certain embodiments described below with respect to FIG. **11**, additional isobutylene can be introduced to the methyl tertiary butyl ether zone **510**, for instance, derived from a metathesis conversion unit.

In operation of one embodiment of the methyl tertiary butyl ether zone **510**, the raffinate stream **504**, contains 35-45%, 37-42.5%, 38-41% or 39-40% isobutylene by weight. This component is removed from the C4 raffinate **516** to attain requisite purity specifications, for instance, greater than or equal to 98 wt % for the 1-butene product stream **522** from the butene-1 recovery zone **520**. Methanol **512**, in certain embodiments high purity methanol having a purity level of greater than or equal to 98 wt % from outside battery limits, and the isobutylene contained in the raffinate stream **504** and in certain embodiments isobutylene **544** from metathesis (shown in dashed lines as an optional feed), react in a primary reactor. In certain embodiments the primary reactor is a fixed bed downflow dehydrogenation reactor and operates for isobutylene conversion in the range

of about 70-95%, 75-95%, 85-95% or 90-95% on a weight basis. Effluent from the primary reactor is routed to a reaction column where reactions are completed. In certain embodiments, exothermic heat of the reaction column and the primary reactor can optionally be used to supplement the column reboiler along with provided steam. The reaction column bottoms contains methyl tertiary butyl ether, trace amounts, for instance, less than 2%, of unreacted methanol, and heavy products produced in the primary reactor and reaction column. Reaction column overhead contains unreacted methanol and non-reactive C4 raffinate. This stream is water washed to remove unreacted methanol and is passed to the 1-butene recovery zone **520** as the C4 raffinate **516**. Recovered methanol is removed from the wash water in a methanol recovery column and recycled to the primary reactor.

The C4 raffinate stream **516** from the methyl tertiary butyl ether zone **510** is passed to a separation zone **520** for butene-1 recovery. In certain embodiments, upstream of the methyl tertiary butyl ether zone **510**, or between the methyl tertiary butyl ether zone **510** and separation zone **520** for butene-1 recovery, a selective hydrogenation zone can also be included (not shown). For instance, in certain embodiments, raffinate from the methyl tertiary butyl ether zone **510** is selectively hydrogenated in a selective hydrogenation unit to produce butene-1. Other co-monomers and paraffins are also co-produced. The selective hydrogenation zone operates in the presence of an effective amount of hydrogen obtained from recycle within the selective hydrogenation zone and make-up hydrogen; in certain embodiments, all or a portion of the make-up hydrogen for the selective hydrogenation zone is derived from the steam cracker hydrogen stream **210** from the olefins recovery train **270**. For instance, a suitable selective hydrogenation zone can include, but is not limited to, systems based on technology commercially available from Axens, IFP Group Technologies, FR; Haldor Topsoe A/S, DK; Clariant International Ltd, CH; Chicago Bridge & Iron Company N.V. (CB&I), NL; Honeywell UOP, US; or Shell Global Solutions, US.

For selective recovery of a 1-butene product stream **522**, and to recover a recycle stream **524** that is routed to the mixed feed steam cracking zone **230**, and/or in certain embodiments described herein routed to a metathesis zone, one or more separation steps are used. For example, 1-butene can be recovered using two separation columns, where the first column recovers olefins from the paraffins and the second column separates 1-butene from the mixture including 2-butene, which is blended with the paraffins from the first column and recycled to the steam cracker as a recycle stream **524**.

In certain embodiments, the C4 raffinate stream **516** from the methyl tertiary butyl ether zone **510** is passed to a first splitter, from which from isobutane, 1-butene, and n-butane are separated from heavier C4 components. Isobutane, 1-butene, and n-butane are recovered as overhead, condensed in an air cooler and sent to a second splitter. Bottoms from the first splitter, which contains primarily cis- and trans-2-butene can be added to the recycle stream **524**, or in certain embodiments described herein passed to a metathesis unit. In certain arrangements, the first splitter overhead enters the mid-point of the second splitter. Isobutane product **526** can optionally be recovered in the overhead (shown in dashed lines), 1-butene product **522** is recovered as a sidecut, and n-butane is recovered as the bottoms stream. Bottoms from both splitters is recovered as all or a portion of recycle stream **524**.

The raw pyrolysis gasoline streams **234** and **254** from the steam crackers are treated and separated into treated naphtha and other fractions. In certain embodiments, all, a substantial portion or a significant portion of the pyrolysis gasoline streams **234** and **254** are passed to the py-gas hydrotreating zone **600**. The raw pyrolysis gasoline streams **234** and **254** are processed in a py-gas hydrotreating zone **600** in the presence of an effective amount of hydrogen obtained from recycle within the py-gas hydrotreating zone **600** and make-up hydrogen **602**. Effluent fuel gas is recovered and, for instance, passed to a fuel gas system. In certain embodiments, all or a portion of the make-up hydrogen **602** is derived from the steam cracker hydrogen stream **210** from the olefins recovery train **270**. For instance, a suitable py-gas hydrotreating zone **600** can include, but is not limited to, systems based on technology commercially available from Honeywell UOP, US; Chevron Lummus Global LLC (CLG), US; Axens, IFP Group Technologies, FR; Haldor Topsoe A/S, DK; or Chicago Bridge & Iron Company N.V. (CB&I), NL.

The py-gas hydrotreating zone **600** is operated under conditions, and utilizes catalyst(s), that can be varied over a relatively wide range. These conditions and catalyst(s) are selected for effective hydrogenation for saturation of certain olefin and diolefin compounds, and if necessary for hydrotreating to remove sulfur and/or nitrogen containing compounds. In certain embodiments, this is carried out in at least two catalytic stages, although other reactor configurations can be utilized. Accordingly, py-gas hydrotreating zone **600** subjects the pyrolysis gasoline streams **234** and **254** to hydrogenation to produce hydrotreated pyrolysis gasoline **604** effective as feed to the aromatics extraction zone **620**. Effluent off-gases are recovered from the py-gas hydrotreating zone **600** and are passed to the olefins recovery train, the saturated gas plant as part of the other gases stream **156**, and/or directly to a fuel gas system. Liquefied petroleum gas can be recovered from the py-gas hydrotreating zone **600** and routed to the mixed feed steam cracking zone, the olefins recovery train and/or the saturated gas plant.

In the py-gas hydrotreating zone **600**, diolefins in the feed and olefins in the C6+ portion of the feed are saturated to produce a naphtha stream **604**, a C5+ feed to the aromatics extraction zone. In certain embodiments, a depentanizing step associated with the py-gas hydrotreating zone **600** separates all or a portion of the C5s, for instance, as additional feed **606** to the mixed feed steam cracking zone **230** and/or as feed to a metathesis unit **530** (as shown, for instance, in FIG. 3, FIG. 5 or FIG. 11). In other embodiments, a depentanizing step associated with the aromatics extraction zone **620** separates all or a portion of the C5s from the hydrotreated naphtha stream **604**, for instance, as additional feed to the mixed feed steam cracking zone **230** and/or as feed to a metathesis unit **530**.

In certain embodiments, pyrolysis gasoline is processed in a first reaction stage for hydrogenation and stabilization. Diolefins are saturated selectively in the first reaction stage, and remaining olefins are saturated in the second reaction stage along with converting feed sulfur into hydrogen sulfide. The pyrolysis gasoline can be treated in a cold hydrotreating unit, therefore reducing the level of aromatics saturation.

In an example of an effective py-gas hydrotreating zone **600**, raw pyrolysis gasoline is passed through a coalescer before entering a feed surge drum. The first stage reactor operates in mixed phase and selectively hydrogenates diolefins to mono-olefins and unsaturated aromatics to side-chain saturated aromatics. Pd-based catalyst materials are effec-

tive. Two parallel first-stage reactors can be used in certain embodiments to allow for regeneration in a continuous process without shutdown. In certain embodiments, the first-stage reactor contains three catalyst beds with cooled first stage separator liquid recycled as quench material between each bed. First-stage effluent is stabilized and separated in a column operating under slight vacuum to reduce temperature. In certain embodiments C5 from the C6+ is drawn, followed by a deoxtanizer to remove C9+ and produce a C6-C8 heart naphtha cut. The column operates under slight vacuum to limit temperature. The first stage product is stripped to remove hydrogen, H₂S, and other light ends. In certain embodiments, the stripped first stage product is depentanized to remove cracked C5, for instance, as feed to a metathesis unit. A second stage reactor operates in vapor phase and removes sulfur and saturates olefins. The second stage product is stripped to remove hydrogen, H₂S, and other light ends. In certain embodiments, both reactors are multi-bed and use product recycle to control reactor temperature rise.

In certain embodiments, the first reaction stage of the py-gas hydrotreating zone **600** operating conditions include:

a reactor inlet temperature (° C.) in the range of from about 80-135, 80-125, 80-115, 95-135, 95-125, 95-115, 100-135, 100-125, 100-115 or 107-111;

a reactor outlet temperature (° C.) in the range of from about 145-230, 145-206, 145-200, 165-230, 165-206, 165-200, 175-230, 175-206, 175-200 or 184-188;

a start of run (SOR) reaction temperature (° C.), as a weighted average bed temperature (WABT), in the range of from about 75-125, 75-115, 75-110, 90-125, 90-115, 90-110, 95-125, 95-115, 95-110 or 99-104;

an end of run (EOR) reaction temperature (° C.), as a WABT, in the range of from about 124-195, 124-180, 124-170, 140-195, 140-180, 140-170, 150-195, 150-180, 150-170 or 158-163;

a reaction inlet pressure (barg) in the range of from about 25-40, 25-35, 25-33, 28-40, 28-35, 28-33, 30-40, 30-35 or 30-33;

a reaction outlet pressure (barg) in the range of from about 23-35, 23-33, 23-31, 25-35, 25-33, 25-31, 28-35, 28-33 or 28-31;

a hydrogen partial pressure (barg) (outlet) in the range of from about 15-25, 15-22, 15-21, 18-25, 18-22, 18-21, 19-25 or 19-22;

a hydrogen treat gas feed rate (SLt/Lt) up to about 180, 165 or 156, in certain embodiments from about 120-180, 120-165, 120-156, 134-180, 134-165, 134-156, 140-180, 140-165 or 140-156;

a liquid quench feed ratio (Lt quench/Lt feed) up to about 0.8, 0.7, 0.6 or 0.5, and in certain embodiments in the range of from about 0.35-0.6, 0.35-0.55, 0.35-0.5, 0.4-0.6, 0.4-0.55, 0.4-0.5, 0.45-0.6, 0.45-0.55 or 0.45-0.5; and

a make-up hydrogen feed rate (SLt/Lt) up to about 60, 55, 47 or 45, in certain embodiments from about 34-55, 34-47, 34-45, 40-55, 40-47, 40-45, 42-55, 42-47 or 42-45.

In certain embodiments, the second reaction stage of the py-gas hydrotreating zone **600** operating conditions include:

a reactor inlet temperature (° C.) in the range of from about 225-350, 225-318, 225-303, 255-350, 255-318, 255-303, 270-350, 270-318, 270-303 or 285-291;

a reactor outlet temperature (° C.) in the range of from about 289-445, 289-405, 289-386, 328-445, 328-405, 328-386, 345-445, 345-405, 345-386 or 364-370;

a start of run (SOR) reaction temperature (° C.), as a weighted average bed temperature (WABT), in the range of

from about 217-336, 217-306, 217-291, 245-336, 245-306, 245-291, 260-336, 260-306, 260-291 or 274-280;

an end of run (EOR) reaction temperature ($^{\circ}$ C.), as a WABT, in the range of from about 325-416, 325-380, 325-362, 305-416, 305-380, 305-362, 325-416, 325-380, 325-362 or 340-346;

a reaction inlet pressure (barg) in the range of from about 25-37, 25-34, 25-32, 28-37, 28-34, 28-32, 29-37, 29-34 or 29-32;

a reaction outlet pressure (barg) in the range of from about 23-35, 23-32, 23-30, 26-35, 26-32, 26-30, 28-35, 28-32 or 28-30;

a hydrogen partial pressure (barg) (outlet) in the range of from about 6-10, 6-9, 7-10 or 7-9;

a hydrogen treat gas feed rate (SLt/Lt) up to about 135, 126, 116 or 110, in certain embodiments from about 84-126, 84-116, 84-110, 95-126, 95-116, 95-110, 100-126, 100-116 or 100-110; and

a make-up hydrogen feed rate (SLt/Lt) up to about 30, 27 or 24, in certain embodiments from about 18-30, 18-27, 18-24, 21-30, 21-27, 21-24, 22-30, 22-27 or 22-24.

An effective quantity of catalyst possessing selective hydrogenation functionality is provided, which generally contain one or more active metal component of metals or metal compounds (oxides or sulfides) selected from Co, Mo, Pt, Pd, Fe, or Ni. The active metal component is typically deposited or otherwise incorporated on a support, such as amorphous alumina, amorphous silica alumina, zeolites, or combinations thereof. Exemplary selective hydrogenation catalyst predominantly use Pd as the active metal component on alumina support, including those commercially available under the trade name Olemax[®] 600 and Olemax[®] 601. Effective liquid hourly space velocity values (h^{-1}), on a fresh feed basis relative to the first stage pyrolysis gasoline reactor catalyst, are in the range of from about 0.1-10.0, 0.1-5.0, 0.1-2.0, 0.3-10.0, 0.3-5.0, 0.3-2.0, 0.5-10.0, 0.5-5.0, 0.5-2.0 or 0.9-1.44. Suitable catalysts used in the first stage pyrolysis gasoline reactor have an expected lifetime in the range of about 18-30, 22-30, 18-26 or 22-26 months.

An effective quantity of second stage pyrolysis gasoline reactor catalyst is provided, including those having hydrogenation functionality and which generally contain one or more active metal component of metals or metal compounds (oxides or sulfides) selected from the Periodic Table of the Elements IUPAC Groups 6-10. In certain embodiments, the active metal component is one or more of Co, Ni, W and Mo. The active metal component is typically deposited or otherwise incorporated on a support, such as amorphous alumina, amorphous silica alumina, zeolites, or combinations thereof. In certain embodiments, the catalyst used in the first stage pyrolysis gasoline reactor includes one or more catalyst selected from Co/Mo, Ni/Mo, Ni/W, and Co/Ni/Mo. Combinations of one or more of Co/Mo, Ni/Mo, Ni/W and Co/Ni/Mo, can also be used. For example, a combination of catalyst particles commercially available under the trade names Olemax[®] 806 and Olemax[®] 807 can be used, with active metal components of Co and Ni/Mo. The combinations can be composed of different particles containing a single active metal species, or particles containing multiple active species. Effective liquid hourly space velocity values (h^{-1}), on a fresh feed basis relative to the first stage pyrolysis gasoline reactor catalyst, are in the range of from about 0.1-10.0, 0.1-5.0, 0.1-2.0, 0.3-10.0, 0.3-5.0, 0.3-2.0, 0.5-10.0, 0.5-5.0, 0.5-2.0 or 0.8-1.2. Suitable catalysts used in the second stage pyrolysis gasoline reactor have an expected lifetime in the range of about 18-30, 22-30, 18-26 or 22-26 months.

Hydrotreated pyrolysis gasoline **604** is routed to the aromatics extraction zone **620**. In certain embodiments to maximize production of petrochemicals, all, a substantial portion or a significant portion of the hydrotreated pyrolysis gasoline **604** is passed to the aromatics extraction zone **620**. In modes of operation in which production of gasoline is the objective some of the hydrotreated pyrolysis gasoline **604** is passed to a gasoline pool (not shown).

The aromatics extraction zone **620** includes, for instance, one or more extractive distillation units, and operates to separate the hydrotreated pyrolysis gasoline into high-purity benzene, toluene, xylenes and C9 aromatics. As depicted in FIG. **10**, a benzene stream **624**, a mixed xylenes stream **626** and a raffinate stream **646** are recovered from the aromatics extraction zone **620**, with the raffinate stream **646** routed to the mixed feed steam cracking zone **230** as additional feed. In addition, a toluene stream **636** and C9+ aromatics stream **638** are passed from the aromatics extraction zone **620** to a toluene and C9+ transalkylation zone **630** for production of additional benzene and xylenes, recycled as stream **640** to the aromatics extraction zone **620**. In certain embodiments ethylbenzene can be recovered (not shown). Heavy aromatics **642** are also recovered from the aromatics extraction zone **620**.

In certain embodiments of operation of the aromatics extraction zone **620**, aromatics are separated from the feed by extractive distillation using, for instance, n-formylmorpholine (NFM), as an extractive solvent. Benzene, toluene, mixed xylenes and C9+ aromatics are separated via distillation. Benzene and mixed xylenes are recovered as product streams **624** and **626**, and toluene **636** and C9+ aromatics **638** are sent to the toluene and C9+ transalkylation zone **630**. The transalkylation zone product stream **640** containing benzene and mixed xylenes is returned to the recovery section of the aromatics extraction zone **620**. A paraffinic raffinate stream **646** is recycled as feed to the mixed feed steam cracking zone **230**. In certain embodiments, the paraffinic raffinate stream **646** is in direct fluid communication with the mixed feed steam cracking zone **230**, that is, the stream is not subject to further catalytic processing prior to the steam cracking step.

Selection of solvent, operating conditions, and the mechanism of contacting the solvent and feed permit control over the level of aromatic extraction. For instance, suitable solvents include n-formylmorpholine, furfural, N-methyl-2-pyrrolidone, dimethylformamide, dimethylsulfoxide, phenol, nitrobenzene, sulfolanes, acetonitrile, furfural, or glycols, and can be provided in a solvent to oil ratio of up to about 20:1, in certain embodiments up to about 4:1, and in further embodiments up to about 2:1. Suitable glycols include diethylene glycol, ethylene glycol, triethylene glycol, tetraethylene glycol and dipropylene glycol. The extraction solvent can be a pure glycol or a glycol diluted with from about 2-10 wt % water. Suitable sulfolanes include hydrocarbon-substituted sulfolanes (e.g., 3-methyl sulfolane), hydroxy sulfolanes (e.g., 3-sulfolanol and 3-methyl-4-sulfolanol), sulfolanyl ethers (e.g., methyl-3-sulfolanyl ether), and sulfolanyl esters (e.g., 3-sulfolanyl acetate).

The aromatic separation apparatus can operate at a temperature in the range of from about 40-200, 40-150, 60-200, 60-150, 86-200 or 80-150 $^{\circ}$ C. The operating pressure of the aromatic separation apparatus can be in the range of from about 1-20, 1-16, 3-20, 3-16, 5-20 or 5-16 barg. Types of apparatus useful as the aromatic separation apparatus in certain embodiments of the system and process described herein include extractive distillation columns.

In one embodiment of operation of the aromatics extraction zone **620**, the feed contains primarily C6+ components, and is fractionated into a "heart cut" of C6-C8, and a heavy C9+ fraction. The C6-C8 cut is routed to the extractive distillation system where aromatics are separated from non-aromatics (saturates) via solvent distillation. The raffinate (non-aromatics) from the C6-C8 is removed and recycled back to the cracking complex as a feedstock. The aromatics are soluble in the solvent and are carried from the bottom of the extractive distillation column to the solvent stripper where they are stripped from the solvent, to recover aromatics extract and lean solvent which is recycled back to the extractive distillation column. The mixed aromatics extract is routed to a series of fractionation columns (a benzene column, a toluene column and a xylene column) where each aromatic species is successively removed, for instance, as benzene stream **624** and mixed xylenes stream **626**. The heavy C9+ fraction is further separated into C9 and C10+ material. The toluene and C9 products are routed to the toluene and C9+ transalkylation zone **630** where they are reacted to form additional benzene and mixed xylenes. This stream is recycled back to the fractionation portion of the aromatics extraction zone **620** to recover the benzene and mixed xylenes as well as to recycle the unconverted toluene and C9 aromatics. The transalkylation effluent does not require re-extraction in the solvent distillation section and therefore is routed to the inlet of the benzene column. In certain embodiments toluene can be recycled to extinction, or approaching extinction. C10 and heavier aromatics are removed as product **642**. In certain embodiments ethylbenzene can be recovered.

The toluene and C9+ transalkylation zone **630** operates under conditions effective to disproportionate toluene and C9+ aromatics into a mixed stream **640** containing benzene, mixed xylenes and heavy aromatics. Product ratio of benzene and xylene can be adjusted by selection of catalyst, feedstock and operating conditions. The transalkylation zone **630** receives as feed the toluene stream **636** and the C9+ aromatics stream **638** from the aromatics extraction zone **620**. A small quantity of hydrogen **632**, in certain embodiments which is obtained all or in part from the hydrogen stream **210** derived from the olefins recovery zone **270**, is supplied for transalkylation reactions. Side cracking reactions occur producing fuel gas stream, for instance, passed to the fuel gas system, and LPG stream **634** that is recycled to mixed feed steam cracking zone. A small amount, such as 0.5-3 wt % of the total feed to the aromatics extraction, of heavy aromatics are produced due to condensation reactions and are passed to the mixed stream **640** for recovery with other heavy aromatics.

In operation of one embodiment of the toluene and C9+ transalkylation zone **630**, toluene and C9 aromatics are reacted with hydrogen under mild conditions to form a mixture of C6-C11 aromatics. The mixed aromatic product stream **640** is recycled back to the aromatics extraction zone **620** where the benzene and mixed xylenes are recovered as products. C7 and C9 aromatics are recycled back as feed to the transalkylation zone **630**, and the C10+ fraction is removed from the aromatics extraction zone **620** as heavy aromatics stream **642**. The disproportionation reactions occur in the presence of an effective quantity of hydrogen. A minimal amount of hydrogen is consumed by cracking reactions under reactor conditions. Purge gas is recycled back to the cracking complex for component recovery.

In certain embodiments, pyrolysis oil streams **236** and **256** can be blended into the fuel oil pool as a low sulfur component, and/or used as carbon black feedstock. In addi-

tional embodiments, either or both of the pyrolysis oil streams **236** and **256** can be fractionated (not shown) into light pyrolysis oil and heavy pyrolysis oil. For instance, light pyrolysis oil can be blended with one or more of the middle distillate streams, so that 0-100% of light pyrolysis oil derived from either or both of the pyrolysis oil streams **236** and **256** is processed to produce diesel fuel product and/or additional feed to the mixed feed steam cracking zone **230**. In another embodiment 0-100% of light pyrolysis oil derived from either or both of the pyrolysis oil streams **236**, **256** can be processed in the gas oil hydrocracking zone **320**. In certain embodiments, all, a substantial portion, a significant portion or a major portion of light pyrolysis oil can be passed to one or both of the diesel hydrotreating zone **180** and/or the vacuum gas oil hydroprocessing zone; any remainder can be blended into the fuel oil pool. Heavy pyrolysis oil can be blended into the fuel oil pool as a low sulfur component, and/or used as a carbon black feedstock. In further embodiments, 0-100% of light pyrolysis oil and/or 0-100% of heavy pyrolysis oil derived from either or both of the pyrolysis oil streams **236**, **256** can be processed in the optional residue treating zone **800**. In certain embodiments, all, a substantial portion, a significant portion or a major portion of the pyrolysis oil streams **236**, **256** (light and heavy) can be processed in the optional residue treating zone **800**.

FIG. **11** depicts embodiments including integration of a metathesis zone **530**. The process of FIG. **11** operates according to the description with respect to FIGS. **6** and **10**, or any of the other embodiments herein, in all other aspects. For instance, a suitable metathesis zone **530** can include, but is not limited to, systems based on technology commercially available from Chicago Bridge & Iron Company N.V. (CB&I), NL.

Feedstocks to the metathesis zone **530** include: a portion **536** of the ethylene product **202**; a C4 Raffinate-3 stream **532** from the 1-butene recovery zone **520**, and the olefinic C5 cut **606** from the py-gas hydrotreating zone **600**. The C4 Raffinate-3 stream **532** is 0-100% of the total C4 Raffinate-3 from the 1-butene recovery zone **520**; any remaining portion **524** can be recycled to the mixed feed steam cracking zone **230**.

Products from the metathesis zone **530** include a propylene product stream **534** and a stream **542**, having a mixture of mostly saturated C4/C5 from a metathesis unit that is recycled to the mixed feed steam cracking zone. In certain embodiments, isobutylene **544** can also be recovered (shown in dashed lines) and routed to the methyl tertiary butyl ether zone **510**. In embodiments that operate without separation of isobutylene, it is included within stream **542**.

In an example of a metathesis zone **530** used in the integrated process herein, the C4 Raffinate-3 stream **532** from the separation zone **520** and the C5 olefins stream **606** from the py-gas hydrotreating zone **600** (or the aromatics extraction zone) pass through a guard bed to remove t-butyl catechol and are mixed with a molar excess of fresh and recycled ethylene. The reactor feed passes through another guard bed to remove other trace contaminants, is heated in a furnace and enters the disproportionation (metathesis) reactor, where propylene is formed. The reactions reach equilibrium conversion. The metathesis reactor effluent contains a mixture of propylene, ethylene, and butenes/butanes, and some C5 and heavier components from by-product reactions. C4 olefins isomerize in the disproportionation reactor and react with ethylene to form additional propylene. In certain embodiments, disproportionation of C5 olefins yields isobutylene by-product for production of additional MTBE. Cooled reactor effluent enters a deethylenizer, which

recycles overhead ethylene to the disproportionation reactor. Deethylenizer bottoms are passed to a depropylenizer, which recovers grade propylene product as overhead. Propylene product purity is >99.5 mol % (polymer grade). In certain embodiments depropylenizer bottoms enter a deisobutylenizer, which recovers isobutylene as overhead for additional feedstock to the MTBE zone **510**.

Deisobutylenizer bottoms are mixed with a recycle stream to dilute the olefin concentration, the mixture is heated and mixed with hydrogen, and routed to a total hydrogenation reactor, which saturates any remaining C4/C5 or heavier olefins and thereby enhances light olefin yields. Cooled reactor effluent is recycled as feedstock to the mixed feed steam cracking zone **230**.

FIG. **12** depicts embodiments in which kerosene sweetening is in an optional unit, that is, the first middle distillate fraction **116** can be routed either through the kerosene sweetening zone **170** or routed to the distillate hydrotreating zone **180**. The process of FIG. **12** operates according to the description with respect to FIGS. **6** and **10**, or any of the other embodiments herein, in all other aspects.

During periods in which maximizing the fuel fraction **172** is desired, the first middle distillate fraction **116** can be routed to the kerosene sweetening zone **170**. During periods in which the feedstock to the mixed feed steam cracking zone **230** is to be maximized, the first middle distillate fraction **116** can be routed to the distillate hydrotreating zone **180**, so as to produce additional hydrotreated naphtha **184**. In additional alternative embodiments, the first middle distillate fraction **116** can be divided (on a volume or weight basis, for example, with a diverter) so that a portion is passed to the distillate hydrotreating zone **180** and the remaining portion is passed to the kerosene sweetening zone **170**.

FIG. **13** depicts embodiments in which kerosene sweetening is eliminated. Accordingly, in the embodiments of FIG. **13**, two middle distillate fractions are used. In this embodiment, a first middle distillate fraction **124** is routed to the distillate hydrotreating zone **180**, and a second middle distillate fraction **134** may be similar to the third middle distillate fraction **126** described in other embodiments herein. In one example using the arrangement shown in FIG. **13**, the first middle distillate fraction **124** contains kerosene range hydrocarbons and medium AGO range hydrocarbons, and the second atmospheric distillation zone middle distillate fraction **134** contains heavy AGO range hydrocarbons. In another example using the arrangement shown in FIG. **13**, the first middle distillate fraction **124** contains kerosene range hydrocarbons and a portion of medium AGO range hydrocarbons and the second middle distillate fraction **134** contains a portion of medium AGO range hydrocarbons and heavy AGO range hydrocarbons. The process of FIG. **13** operates according to the description with respect to FIGS. **6** and **10**, or any of the other embodiments herein, in all other aspects.

Advantageously, process dynamics of the configurations and the integration of units and streams attain a very high level of integration of utility streams between the mixed feed steam cracking and other process units, result in increased efficiencies and reduced overall operating costs. For instance, the hydrogen can be tightly integrated so that the net hydrogen demand from outside of the battery limits is minimized or even eliminated. In certain embodiments, the overall hydrogen utilization from outside of the battery limits is less than about 40, 30, 15, 10 or 5 wt % hydrogen based on the total hydrogen required by the hydrogen users in the integrated process. Hydrogen is recovered from the olefins recovery train, and is supplied to the hydrogen users

in the system, including the diesel hydrotreater, the gas oil hydrotreater, the py-gas hydrotreater, and transalkylation, so as to derive most or all of the utility hydrogen from within the battery limits. In certain embodiments there is zero external hydrogen use, in which make-up hydrogen is only required to initiate the operations; when the reactions reach equilibrium, the hydrogen derived from the mixed feed steam cracking and gas oil steam cracking products provides sufficient hydrogen to maintain the hydrogen requirements of the hydrogen users in the integrated process. In further embodiments, there is a net hydrogen gain, so that hydrogen can be added, for instance, to the fuel gas that is used to operate the various heating units within the integrated process.

Furthermore, the integrated process described herein offers useful outlets for the off-gases and light ends from the hydroprocessing units. For instance, the stream **156** that is passed to the saturated gas plant **150** of the crude complex **100** can contain off-gases and light ends from the hydroprocessing units, such as the diesel hydrotreating zone **180**, the gas oil hydrocracking zone **320** and/or from the py-gas hydrotreating zone **600**. In other embodiments, in combination with or as an alternative to the passing these off-gases and light ends to stream **156**, all or a portion can be routed to the mixed feed steam cracking unit **230**. For instance, C2s can be separated from the mixture of methane, hydrogen and C2s using a cold distillation section ("cold box") including cryogenic distillation/separation operations, which can be integrated with any or all of the mixed feed steam cracking unit **230**, the saturated gas plant **150** and/or the olefins recovery zone **270**. Methane and hydrogen can be passed to a fuel gas system or to an appropriate section of the olefins recovery zone **270**, such as the hydrogen purification system. In still further embodiments, in combination with or as an alternative to the passing these off-gases and light ends to stream **156** and/or routing them to the mixed feed steam cracking unit **230**, all or a portion can be routed to an appropriate section of the olefins recovery zone **270**, such as the depropanizer, or combining the gases with the depropanizer overheads.

The unique configurations presented herein set forth a level of integration, of streams and units that allows the use of gas oil steam crackers in an economically efficient manner. The configurations support and enhance chemical conversion using integrated processes with crude oil as a feed. Hence, not only do these configurations permit lower capital expenditure relative to conventional approaches of chemical production from fuels or refinery by-products, but it also exhibits an economical use of the gas oil cracker (through the integration). Accordingly, despite the use of crude oil as the feed, the processes herein are comparable to other options currently common in the industry such as ethane crackers that benefit from availability of ethane as a feed.

Embodiments described herein provide the ability to achieve a crude to chemical conversion ratio in the range of, for instance, up to 80, 50 or 45 wt %, and in certain embodiments in the range of about 39-45 wt %. In certain embodiments the chemical conversion ratio is at least about 39 wt %, and in certain embodiments in the range of about 39-80, 39-50 or, 39-45 wt %. It should be appreciated that this crude to chemicals conversion ratio can vary depending on criteria such as feed, selected technology, catalyst selection and operating conditions for the individual unit operations.

In some embodiments, individual unit operations can include a controller to monitor and adjust the product slate as desired. A controller can direct parameters within any of

the individual unit operations the apparatus depending upon the desired operating conditions, which may, for example, be based on customer demand and/or market value. A controller can adjust or regulate valves, feeders or pumps associated with one or more unit operations based upon one or more signals generated by operator data input and/or automatically retrieved data.

Such controllers provide a versatile unit having multiple modes of operation, which can respond to multiple inputs to increase the flexibility of the recovered product. The controller can be implemented using one or more computer systems which can be, for example, a general-purpose computer. Alternatively, the computer system can include specially-programmed, special-purpose hardware, for example, an application-specific integrated circuit (ASIC) or controllers intended for a particular unit operation within a refinery.

The computer system can include one or more processors typically connected to one or more memory devices, which can comprise, for example, any one or more of a disk drive memory, a flash memory device, a RAM memory device, or other device for storing data. The memory is typically used for storing programs and data during operation of the system. For example, the memory can be used for storing historical data relating to the parameters over a period of time, as well as operating data. Software, including programming code that implements embodiments of the invention, can be stored on a computer readable and/or writeable nonvolatile recording medium, and then typically copied into memory wherein it can then be executed by one or more processors. Such programming code can be written in any of a plurality of programming languages or combinations thereof.

Components of the computer system can be coupled by one or more interconnection mechanisms, which can include one or more busses, for instance, between components that are integrated within a same device, and/or a network, for instance, between components that reside on separate discrete devices. The interconnection mechanism typically enables communications, for instance, data and instructions, to be exchanged between components of the system.

The computer system can also include one or more input devices, for example, a keyboard, mouse, trackball, microphone, touch screen, and other man-machine interface devices as well as one or more output devices, for example, a printing device, display screen, or speaker. In addition, the computer system can contain one or more interfaces that can connect the computer system to a communication network, in addition or as an alternative to the network that can be formed by one or more of the components of the system.

According to one or more embodiments of the processes described herein, the one or more input devices can include sensors and/or flow meters for measuring any one or more parameters of the apparatus and/or unit operations thereof. Alternatively, one or more of the sensors, flow meters, pumps, or other components of the apparatus can be connected to a communication network that is operatively coupled to the computer system. Any one or more of the above can be coupled to another computer system or component to communicate with the computer system over one or more communication networks. Such a configuration permits any sensor or signal-generating device to be located at a significant distance from the computer system and/or allow any sensor to be located at a significant distance from any subsystem and/or the controller, while still providing data therebetween. Such communication mechanisms can be

affected by utilizing any suitable technique including but not limited to those utilizing wired networks and/or wireless networks and protocols.

Although the computer system is described above by way of example as one type of computer system upon which various aspects of the processes herein can be practiced, it should be appreciated that the invention is not limited to being implemented in software, or on the computer system as exemplarily described. Indeed, rather than implemented on, for example, a general purpose computer system, the controller, or components or subsections thereof, can alternatively be implemented as a dedicated system or as a dedicated programmable logic controller (PLC) or in a distributed control system. Further, it should be appreciated that one or more features or aspects of the processes can be implemented in software, hardware or firmware, or any combination thereof. For example, one or more segments of an algorithm executable by a controller can be performed in separate computers, which in turn, can be in communication through one or more networks.

In some embodiments, one or more sensors and/or flow meters can be included at locations throughout the process, which are in communication with a manual operator or an automated control system to implement a suitable process modification in a programmable logic controlled process. In one embodiment, a process includes a controller which can be any suitable programmed or dedicated computer system, PLC, or distributed control system. The flow rates of certain product streams can be measured, and flow can be redirected as necessary to meet the requisite product slate.

Factors that can result in various adjustments or controls include customer demand of the various hydrocarbon products, market value of the various hydrocarbon products, feedstock properties such as API gravity or heteroatom content, and product quality (for instance, gasoline and middle distillate indicative properties such as octane number for gasoline and cetane number for middle distillates).

The disclosed processes and systems create new outlets for direct conversion of crude oil, for instance, light crudes such as Arab Extra Light (AXL) or Arab Light (AL) crude oil. Additionally, the disclosed processes and systems offer novel configurations that, compared to known processes and systems, requires lower capital expenditure relative to conventional approaches of chemical production from fuels or refinery by-products and that utilize refining units and an integrated chemicals complex. The disclosed processes and systems substantially increase the proportion of crude oil that is converted to high purity chemicals that traditionally command high market prices. Complications resulting from advancing the threshold of commercially proven process capacities are minimized or eliminated using the processes and systems described herein.

The disclosed processes and systems utilize different commercially proven units arranged in novel configurations. These novel configurations enable production of refined products and petrochemical products including olefins, aromatics, MTBE, and butadiene. The disclosed processes and systems allow chemicals producers to de-couple from fuel markets and have more freedom to increase chemical yields as a fraction of crude rate, as compared to traditional chemical production using refinery intermediates or by-products as feedstock. Also, the disclosed processes and systems substantially increase the proportion of crude oil that is converted to high purity chemicals that traditionally command high market prices.

The disclosed processes and systems provide alternatives for chemicals production that have lower capital investment

relative to conventional routes that utilize refining units and an integrated chemicals complex. Moreover, the disclosed processes and systems offer the flexibility of simultaneously producing fuel products and chemical products. The ratio of chemicals to residual fuels can be modulated by process operations to address changing fuels and chemical market opportunities. In certain embodiments, the process configurations are flexible to enable processing of crude oil, such as Arab Light or Arab Extra Light, to provide superior production of chemical products, while minimizing the production of refined fuel products. The configurations offer the flexibility to structure operations to adjust the ratio of petrochemicals to refined products in order to achieve optimum operations and allows shifting the production ratio of chemicals to fuels, thereby adjusting to market conditions.

For example, in vacuum gas oil hydroprocessing, as severity increases, the yield of UCO decreases as the naphtha yield increases, although for the most part the distillate yield does change as much because wild naphtha product is the result of distillate cracking. The UCO product is chemically restructured through ring opening reactions to become much more paraffinic in nature, and remains a gas oil boiling range product. By modulating severity of vacuum gas oil hydroprocessing, the shift is between naphtha and UCO relative product rates. The olefin yield of naphtha in the steam cracker is superior to UCO; while the heavy product yield (mixed C4s and pyrolysis gasoline) from UCO is superior to naphtha. Therefore, a key advantage of modulating the vacuum gas oil hydroprocessing conversion is to economically and dynamically address changing market conditions for olefin and aromatic products, which may swing dramatically.

Each of the processing units are operated at conditions typical for such units, which conditions can be varied based on the type of feed to maximize, within the capability of the unit's design, the desired products. Desired products can include fractions suitable as feedstock to the mixed feed steam cracking zone 230 or gas oil steam cracking zone 250, or fractions suitable for use as fuel products. Likewise, processing units employ appropriate catalyst(s) depending upon the feed characteristics and the desired products. Certain embodiments of these operating conditions and catalysts are described herein, although it shall be appreciated that variations are well known in the art and are within the capabilities of those skilled in the art.

For the purpose of the simplified schematic illustrations and descriptions herein, accompanying components that are conventional in crude centers, such as the numerous valves, temperature sensors, preheater(s), desalting operation(s), and the like are not shown.

In addition, accompanying components that are in conventional hydroprocessing units such as, for example, hydrogen recycle sub-systems, bleed streams, spent catalyst discharge sub-systems, and catalyst replacement sub-systems the like are not shown.

Further, accompanying components that are in conventional thermal cracking systems such as steam supplies, coke removal sub-systems, pyrolysis sections, convection sections and the like are not shown.

The method and system of the present invention have been described above and in the attached drawings; however, modifications will be apparent to those of ordinary skill in the art and the scope of protection for the invention is to be defined by the claims that follow.

The invention claimed is:

1. An integrated process for producing petrochemicals and fuel products from a crude oil feed comprising:

separating from the crude oil feed, in an atmospheric distillation unit (ADU), at least

a first ADU fraction comprising straight run naphtha, a second ADU fraction comprising at least a portion of middle distillates from the crude oil feed, and

a third ADU fraction comprising atmospheric residue; separating from the third ADU fraction, in a vacuum distillation unit (VDU), at least

a first VDU fraction comprising vacuum gas oil;

hydroprocessing in a distillate hydroprocessing (DHP) zone middle distillates from the second ADU fraction, and recovering at least a first DHP fraction and a second DHP fraction, wherein the first DHP fraction comprises naphtha and the second DHP fraction is used for diesel fuel production;

hydrocracking in a gas oil hydrocracking (GOHCK) zone vacuum gas oil from the first VDU fraction, and recovering a first GOHCK fraction containing components boiling at or below an atmospheric residue end boiling point and including LPG, naphtha and middle distillate range components, and unconverted gas oil; steam cracking, in a mixed feed steam cracking (MFSC) zone, naphtha from the first ADU fraction and raffinate derived from an aromatics extraction zone, and, in a gas oil steam cracking (GOSC) zone, unconverted oil, wherein steam cracking operates under conditions effective to recover at least a mixed product stream H₂, methane, ethane, ethylene, mixed C₃s and mixed C₄s; pyrolysis gas; and pyrolysis oil;

recovering, from the mixed product stream, H₂, methane, non-olefinic C₂-C₄s, and petrochemicals ethylene, propylene and butylenes,

hydroprocessing pyrolysis gas from steam cracking in a naphtha hydroprocessing zone, and recovering hydrotreated pyrolysis gas; and

separating aromatics from hydrotreated pyrolysis gas in the aromatics extraction zone for recovery of petrochemical aromatic products, and aromatics extraction zone raffinate, wherein the raffinate derived from aromatics extraction is all or a portion of the aromatics extraction zone raffinate.

2. The process as in claim 1, wherein the GOHCK zone is a two-stage with recycle configuration operating in a full conversion mode of operation, in the presence of hydrocracking catalyst to convert 78-99 wt % of feed to the GOHCK zone into the first GOHCK fraction.

3. The process as in claim 2, wherein the two-stage with recycle configuration includes a first stage reactor and a second stage reactor, and wherein operating conditions in the first stage reactor include:

a reactor inlet temperature (° C.) in the range of from about 340-502;

a reactor outlet temperature (° C.) in the range of from about 350-516;

a start of run (SOR) reaction temperature (° C.), as a weighted average bed temperature (WABT), in the range of from about 310-475;

an end of run (EOR) reaction temperature (° C.), as a WABT, in the range of from about 338-516;

a reaction inlet pressure (barg) in the range of from about 100-180;

a reaction outlet pressure (barg) in the range of from about 90-170;

a hydrogen partial pressure (barg) (outlet) in the range of from about 90-137;

a hydrogen treat gas feed rate (SLt/Lt) up to about 1050;

57

a hydrogen quench gas feed rate (SLt/Lt) up to about 1100;
 a make-up hydrogen feed rate (SLt/Lt) up to about 564;
 and
 a liquid hourly space velocity (h^{-1}), on a fresh feed basis relative to the hydrotreating catalysts, in the range of from about 0.1-10.0;
 and
 operating conditions in the second stage reactor include:
 a reactor inlet temperature ($^{\circ}C.$) in the range of from about 340-502;
 a reactor outlet temperature ($^{\circ}C.$) in the range of from about 350-516;
 a start of run (SOR) reaction temperature ($^{\circ}C.$), as a weighted average bed temperature (WABT), in the range of from about 310-475;
 an end of run (EOR) reaction temperature ($^{\circ}C.$), as a WABT, in the range of from about 338-516;
 a reaction inlet pressure (barg) in the range of from about 80-145;
 a reaction outlet pressure (barg) in the range of from about 75-137;
 a hydrogen partial pressure (barg) (outlet) in the range of from about 90-145;
 a hydrogen treat gas feed rate (SLt/Lt) up to about 910;
 a hydrogen quench gas feed rate (SLt/Lt) up to about 980;
 a make-up hydrogen feed rate (SLt/Lt) up to about 451;
 and
 a liquid hourly space velocity (h^{-1}), on a fresh feed basis relative to the hydrotreating catalysts, in the range of from about 0.1-10.0.
 4. The process as in claim 1, wherein the GOHCK zone is a once-through series configuration operating in a partial conversion mode of operation, in the presence of hydrocracking catalyst, to convert 48-82 wt % of feed to the GOHCK zone into the first GOHCK fraction.
 5. The process as in claim 4, wherein once-through series configuration includes a first reactor and a second reactor, and wherein operating conditions in the first reactor include:
 a reactor inlet temperature ($^{\circ}C.$) in the range of from about 340-502;
 a reactor outlet temperature ($^{\circ}C.$) in the range of from about 350-516;
 a start of run (SOR) reaction temperature ($^{\circ}C.$), as a weighted average bed temperature (WABT), in the range of from about 310-475;
 an end of run (EOR) reaction temperature ($^{\circ}C.$), as a WABT, in the range of from about 338-516;
 a reaction inlet pressure (barg) in the range of from about 100-165;
 a reaction outlet pressure (barg) in the range of from about 92-150;
 a hydrogen partial pressure (barg) (outlet) in the range of from about 80-120;
 a hydrogen treat gas feed rate (SLt/Lt) up to about 668;
 a hydrogen quench gas feed rate (SLt/Lt) up to about 819;
 a make-up hydrogen feed rate (SLt/Lt) up to about 271;
 and
 a liquid hourly space velocity (h^{-1}), on a fresh feed basis relative to the hydrotreating catalysts, in the range of from about 0.1-10.0;
 and
 operating conditions in the second reactor include:
 a reactor inlet temperature ($^{\circ}C.$) in the range of from about 340-502;
 a reactor outlet temperature ($^{\circ}C.$) in the range of from about 350-516;

58

a start of run (SOR) reaction temperature ($^{\circ}C.$), as a weighted average bed temperature (WABT), in the range of from about 310-475;
 an end of run (EOR) reaction temperature ($^{\circ}C.$), as a WABT, in the range of from about 338-516;
 a reaction inlet pressure (barg) in the range of from about 90-150;
 a reaction outlet pressure (barg) in the range of from about 85-140;
 a hydrogen partial pressure (barg) (outlet) in the range of from about 80-130;
 a hydrogen treat gas feed rate (SLt/Lt) up to about 890;
 a hydrogen quench gas feed rate (SLt/Lt) up to about 850;
 a make-up hydrogen feed rate (SLt/Lt) up to about 372;
 and
 a liquid hourly space velocity (h^{-1}), on a fresh feed basis relative to the hydrotreating catalysts, in the range of from about 0.1-10.0.
 6. The process as in claim 1, wherein the GOHCK zone is a once-through (single stage without recycle) configuration operating in a partial conversion in the presence of hydrocracking catalyst to convert 48-82 wt % of feed to the GOHCK zone into the first GOHCK fraction.
 7. The process as in claim 6, wherein the once-through (single stage without recycle) configuration operating conditions include:
 a reactor inlet temperature ($^{\circ}C.$) in the range of from about 340-502;
 a reactor outlet temperature ($^{\circ}C.$) in the range of from about 350-516;
 a start of run (SOR) reaction temperature ($^{\circ}C.$), as a weighted average bed temperature (WABT), in the range of from about 310-475;
 an end of run (EOR) reaction temperature ($^{\circ}C.$), as a WABT, in the range of from about 338-516;
 a reaction inlet pressure (barg) in the range of from about 100-165;
 a reaction outlet pressure (barg) in the range of from about 92-150;
 a hydrogen partial pressure (barg) (outlet) in the range of from about 80-120;
 a hydrogen treat gas feed rate (SLt/Lt) up to about 677;
 a hydrogen quench gas feed rate (SLt/Lt) up to about 614;
 a make-up hydrogen feed rate (SLt/Lt) up to about 305;
 and
 a liquid hourly space velocity (h^{-1}), on a fresh feed basis relative to the hydrotreating catalysts, in the range of from about 0.1-10.0.
 8. The process as in claim 1, wherein the GOHCK is a once-through (single stage without recycle) configuration operating in a mild hydrocracking mode in the presence of hydrocracking catalyst to convert 27-52 wt % of feed to the GOHCK zone into the first GOHCK fraction.
 9. The process as in claim 8, wherein the once-through (single stage without recycle) configuration operating conditions include:
 a reactor inlet temperature ($^{\circ}C.$) in the range of from about 329-502;
 a reactor outlet temperature ($^{\circ}C.$) in the range of from about 338-516;
 a start of run (SOR) reaction temperature ($^{\circ}C.$), as a weighted average bed temperature (WABT), in the range of from about 310-475;
 an end of run (EOR) reaction temperature ($^{\circ}C.$), as a WABT, in the range of from about 338-516;
 a reaction inlet pressure (barg) in the range of from about 108-161;

a reaction outlet pressure (barg) in the range of from about 100-150;

a hydrogen partial pressure (barg) (outlet) in the range of from about 77-116;

a hydrogen treat gas feed rate (SLt/Lt) up to about 530;

a hydrogen quench gas feed rate (SLt/Lt) up to about 470;

a make-up hydrogen feed rate (SLt/Lt) up to about 225; and

a liquid hourly space velocity (h^{-1}), on a fresh feed basis relative to the hydrotreating catalysts, in the range of from about 0.1-10.0.

10. The process as in claim 1, further wherein the middle distillates in the second ADU fraction comprise heavy atmospheric gas oil that is routed to the GOHCK zone.

11. The process as in claim 1, further wherein the middle distillates in the second ADU fraction comprise heavy atmospheric gas oil that is processed in the GOSC zone without hydroprocessing.

12. The process as in claim 1, wherein the middle distillates in the second ADU fraction comprise kerosene that is processed in a kerosene sweetening process to recover a kerosene fuel product, and a straight run diesel fraction that is the portion of the second ADU fraction that is processed in the distillate hydroprocessing zone.

13. The process as in claim 12, further wherein the middle distillates in the second ADU fraction comprise heavy atmospheric gas oil that is processed in the GOHCK zone or the GOSC zone.

14. The process as in claim 1, wherein at least a significant portion of the first DHP fraction is passed to the MFSC zone or to the ADU.

15. The process as in claim 1, wherein at least a significant portion of naphtha from the first GOHCK fraction is routed to the mixed feed stream cracking zone or to the atmospheric distillation zone.

16. The process as in claim 15, wherein all or a portion of the first GOHCK fraction is routed to the distillate hydroprocessing zone.

17. The process as in claim 1, wherein non-olefinic C4s recovered from the mixed product stream are recycled to the mixed feed stream cracking zone.

18. The process as in claim 1, wherein non-olefinic C4s recovered from the mixed product stream are recycled to the separate processing zone for production of additional petrochemicals.

19. The process as in claim 18, further comprising recovering C5s from the hydrotreated pyrolysis gas; passing the recovered C5s to the separate processing zone for production of additional petrochemicals; passing a portion of the recovered ethylene to the separate processing zone;

wherein the separate processing zone is a metathesis reaction zone which produces petrochemical propylene and a C4/C5 raffinate stream that is recycled to the mixed feed stream cracking zone.

20. The process as in claim 1, further comprising recovering C5s from the hydrotreated pyrolysis gas and passing the recovered C5s to the MFSC zone, the separate processing zone for production of additional petrochemicals, or both to the mixed feed stream cracking zone and the separate processing zone for production of additional petrochemicals.

21. The process as in claim 20 wherein the recovered C5s are passed to the mixed feed stream cracking zone.

22. The process as in claim 20 wherein the recovered C5s are passed to the separate processing zone for production of additional petrochemicals, wherein the separate processing zone converts mixture of butenes into mixed butanols.

23. The process as in claim 1, wherein a crude to chemicals conversion ratio of at least about 39 wt % is achieved.

24. The process as in claim 18, wherein the separate processing zone converts mixture of butenes into mixed butanols.

25. The process as in claim 3, further wherein at least a significant portion of the first DHP fraction is passed to the MFSC zone or to the ADU; and

at least a significant portion of naphtha from the first GOHCK fraction is routed to the mixed feed stream cracking zone, the atmospheric distillation zone or the distillate hydroprocessing zone.

26. The process as in claim 25, wherein the middle distillates in the second ADU fraction comprise

kerosene that is processed in a kerosene sweetening process to recover a kerosene fuel product,

a straight run diesel fraction that is the portion of the second ADU fraction that is processed in the distillate hydroprocessing zone, and

heavy atmospheric gas oil that is routed to the GOHCK zone or processed in the GOSC zone without hydroprocessing.

27. The process as in claim 25, further comprising routing non-olefinic C4s recovered from the mixed product stream, C5s recovered from hydrotreated pyrolysis gas, and a portion of recovered ethylene, to a metathesis reaction zone which produces petrochemical propylene and a C4/C5 raffinate stream that is recycled to the mixed feed stream cracking zone.

28. The process as in claim 25, further comprising routing non-olefinic C4s recovered from the mixed product stream to a separate processing zone for conversion of the mixture of butenes into mixed butanols and a raffinate that is passed to the MFSC zone; and recovering C5s from the hydrotreated pyrolysis gas and passing the recovered C5s to the MFSC zone.

29. The process as in claim 5, further wherein at least a significant portion of the first DHP fraction is passed to the MFSC zone or to the ADU; and at least a significant portion of naphtha from the first GOHCK fraction is routed to the mixed feed stream cracking zone, the atmospheric distillation zone or the distillate hydroprocessing zone.

30. The process as in claim 29, wherein the middle distillates in the second ADU fraction comprise

kerosene that is processed in a kerosene sweetening process to recover a kerosene fuel product,

a straight run diesel fraction that is the portion of the second ADU fraction that is processed in the distillate hydroprocessing zone, and

heavy atmospheric gas oil that is routed to the GOHCK zone or processed in the GOSC zone without hydroprocessing.

31. The process as in claim 29, further comprising routing non-olefinic C4s recovered from the mixed product stream, C5s recovered from hydrotreated pyrolysis gas, and a portion of recovered ethylene, to a metathesis reaction zone which produces petrochemical propylene and a C4/C5 raffinate stream that is recycled to the mixed feed stream cracking zone.

32. The process as in claim 29, further comprising routing non-olefinic C4s recovered from the mixed product stream to a separate processing zone for conversion of the mixture of butenes into mixed butanols and a raffinate that is passed to the MFSC zone; and

61

recovering C5s from the hydrotreated pyrolysis gas and passing the recovered C5s to the MFSC zone.

33. The process as in claim 7, further wherein at least a significant portion of the first DHP fraction is passed to the MFSC zone or to the ADU; and at least a significant portion of naphtha from the first GOHCK fraction is routed to the mixed feed stream cracking zone, the atmospheric distillation zone or the distillate hydroprocessing zone.

34. The process as in claim 33, wherein the middle distillates in the second ADU fraction comprise kerosene that is processed in a kerosene sweetening process to recover a kerosene fuel product, a straight run diesel fraction that is the portion of the second ADU fraction that is processed in the distillate hydroprocessing zone, and heavy atmospheric gas oil that is routed to the GOHCK zone or processed in the GOSC zone without hydro-processing.

35. The process as in claim 33, further comprising routing non-olefinic C4s recovered from the mixed product stream, C5s recovered from hydrotreated pyrolysis gas, and a portion of recovered ethylene, to a metathesis reaction zone which produces petrochemical propylene and a C4/C5 raffinate stream that is recycled to the mixed feed stream cracking zone.

36. The process as in claim 33, further comprising routing non-olefinic C4s recovered from the mixed product stream to a separate processing zone for conversion of the mixture of butenes into mixed butanols and a raffinate that is passed to the MFSC zone; and recovering C5s from the hydrotreated pyrolysis gas and passing the recovered C5s to the MFSC zone.

62

37. The process as in claim 9, further wherein at least a significant portion of the first DHP fraction is passed to the MFSC zone or to the ADU; and at least a significant portion of naphtha from the first GOHCK fraction is routed to the mixed feed stream cracking zone, the atmospheric distillation zone or the distillate hydroprocessing zone.

38. The process as in claim 37, wherein the middle distillates in the second ADU fraction comprise kerosene that is processed in a kerosene sweetening process to recover a kerosene fuel product, a straight run diesel fraction that is the portion of the second ADU fraction that is processed in the distillate hydroprocessing zone, and heavy atmospheric gas oil that is routed to the GOHCK zone or processed in the GOSC zone without hydro-processing.

39. The process as in claim 37, further comprising routing non-olefinic C4s recovered from the mixed product stream, C5s recovered from hydrotreated pyrolysis gas, and a portion of recovered ethylene, to a metathesis reaction zone which produces petrochemical propylene and a C4/C5 raffinate stream that is recycled to the mixed feed stream cracking zone.

40. The process as in claim 37, further comprising routing non-olefinic C4s recovered from the mixed product stream to a separate processing zone for conversion of the mixture of butenes into mixed butanols and a raffinate that is passed to the MFSC zone; and recovering C5s from the hydrotreated pyrolysis gas and passing the recovered C5s to the MFSC zone.

* * * * *