



(19) **United States**

(12) **Patent Application Publication**
MacKay et al.

(10) **Pub. No.: US 2024/0203192 A1**

(43) **Pub. Date: Jun. 20, 2024**

(54) **PARKING METER HAVING TOUCHSCREEN DISPLAY**

Publication Classification

(71) Applicant: **J.J. MacKay Canada Limited**, New Glasgow (CA)

- (51) **Int. Cl.**
- G07F 17/24* (2006.01)
- G06F 1/3231* (2006.01)
- G06F 3/041* (2006.01)
- G06F 3/04886* (2006.01)
- G06F 3/14* (2006.01)
- G06K 7/00* (2006.01)
- G06Q 20/18* (2006.01)
- G06Q 30/0283* (2006.01)

(72) Inventors: **George Allan MacKay**, New Glasgow (CA); **James George MacKay**, Frasers Mountain (CA); **Adrian Ignatius O'Neil**, New Glasgow (CA); **Gregory Emile Chauvin**, Brookside (CA); **Neil Stuart Erskine**, Halifax (CA)

- (52) **U.S. Cl.**
- CPC *G07F 17/24* (2013.01); *G06F 1/3231* (2013.01); *G06F 3/041* (2013.01); *G06F 3/04886* (2013.01); *G06F 3/14* (2013.01); *G06K 7/0021* (2013.01); *G06Q 20/18* (2013.01); *G06Q 30/0284* (2013.01)

(21) Appl. No.: **18/435,090**

(22) Filed: **Feb. 7, 2024**

Related U.S. Application Data

(63) Continuation of application No. 17/005,479, filed on Aug. 28, 2020, now Pat. No. 11,922,756, which is a continuation-in-part of application No. 16/774,099, filed on Jan. 28, 2020, now Pat. No. 11,762,479.

Foreign Application Priority Data

Jan. 30, 2019 (CA) 3031936

(57) **ABSTRACT**

A parking meter may incorporate a touchscreen display assembly that uses a low-power wake trigger, which may be a proximity sensor overlaid on the display, that can power on the display and touch sensor when a user's proximity is detected. The parking meter may incorporate a replaceable panel insert that allows user interface components to be easily retrofitted or upgraded by simply replacing the panel insert. Additionally, the parking meter may incorporate multiple solar panels on the exterior of the parking meter.

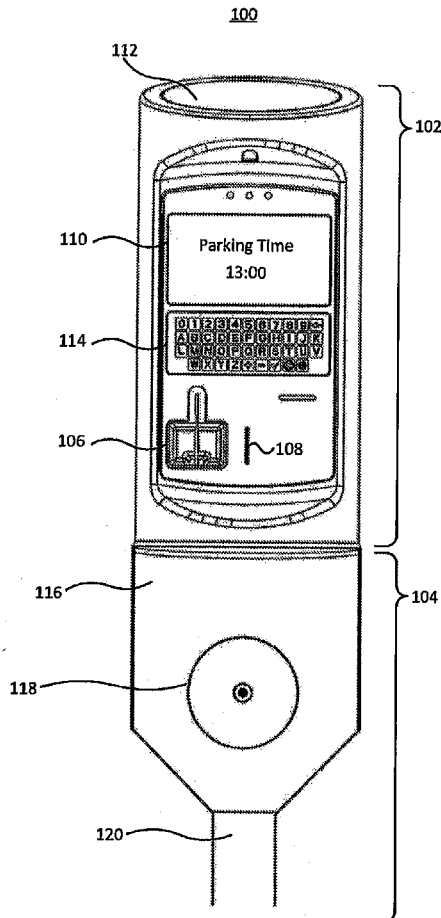

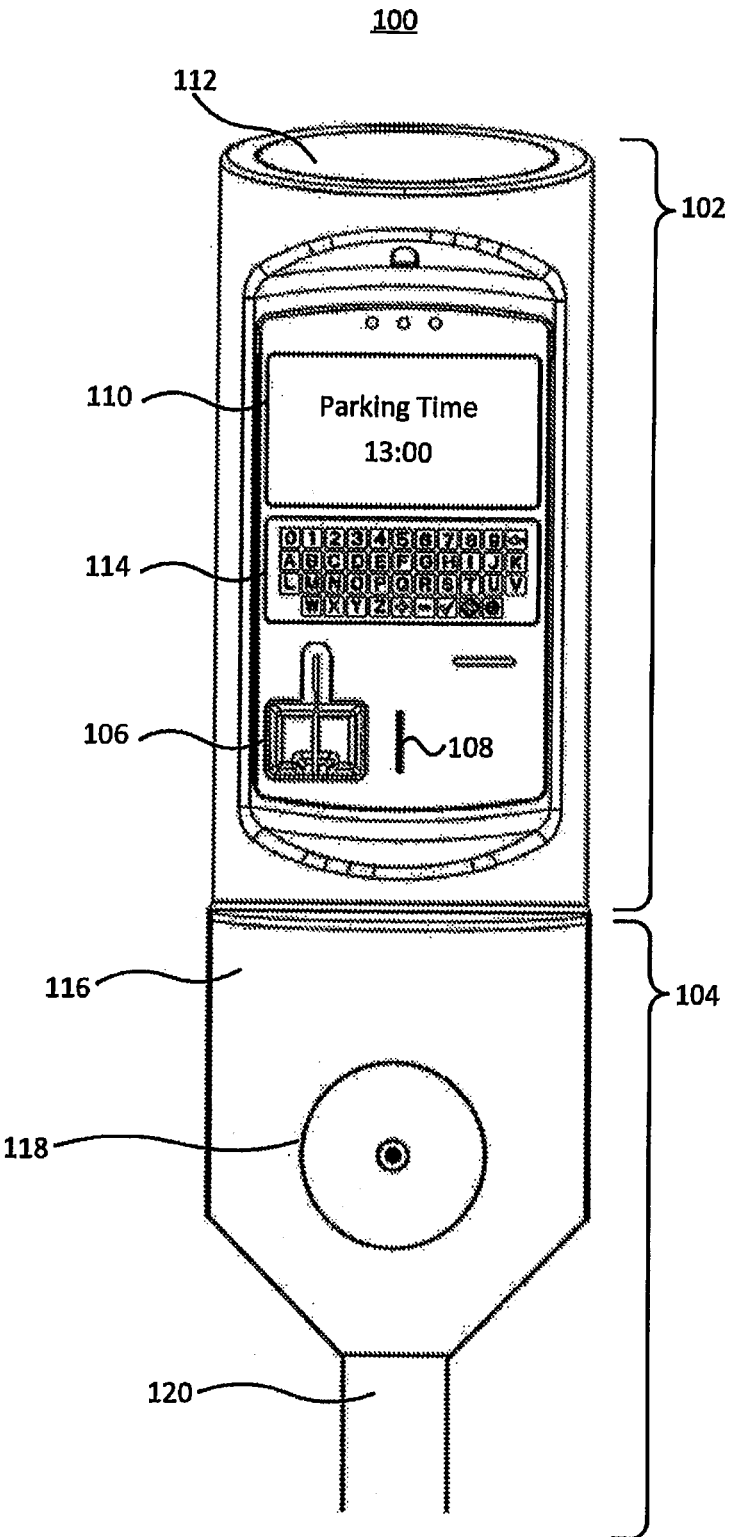

FIG. 1

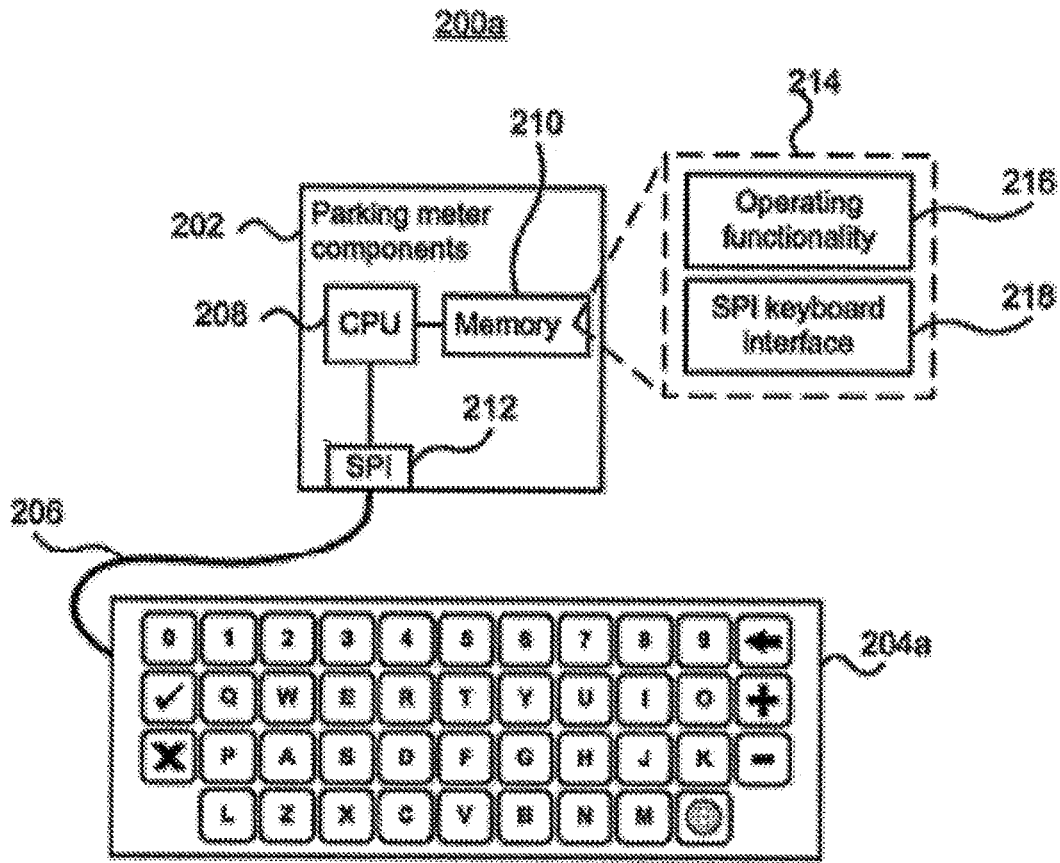

FIG. 2A

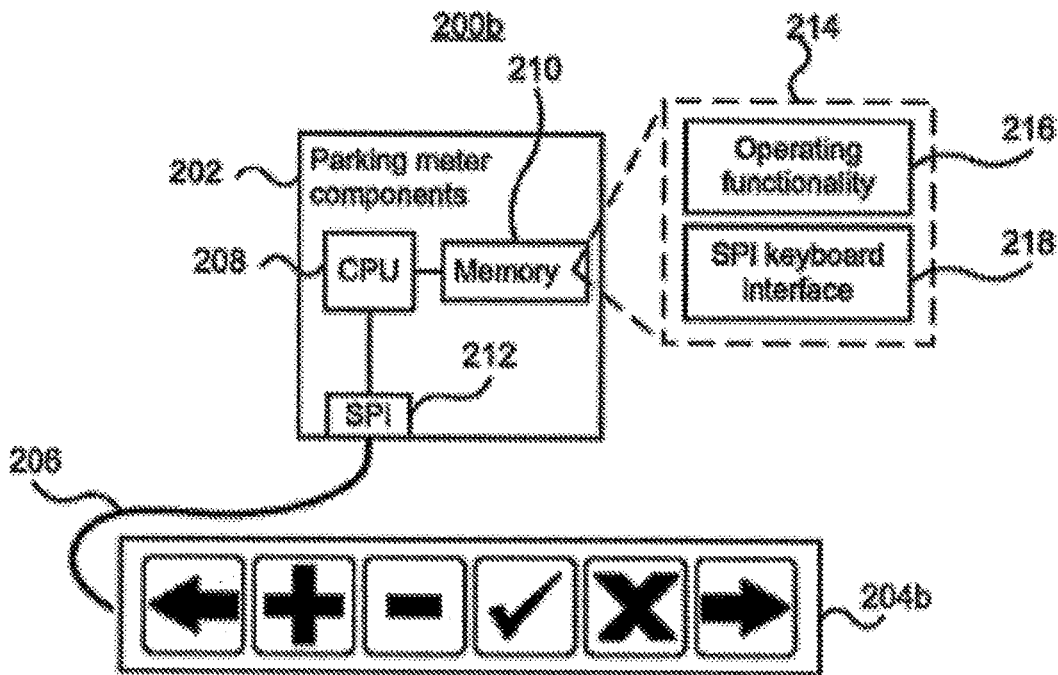

FIG. 2B

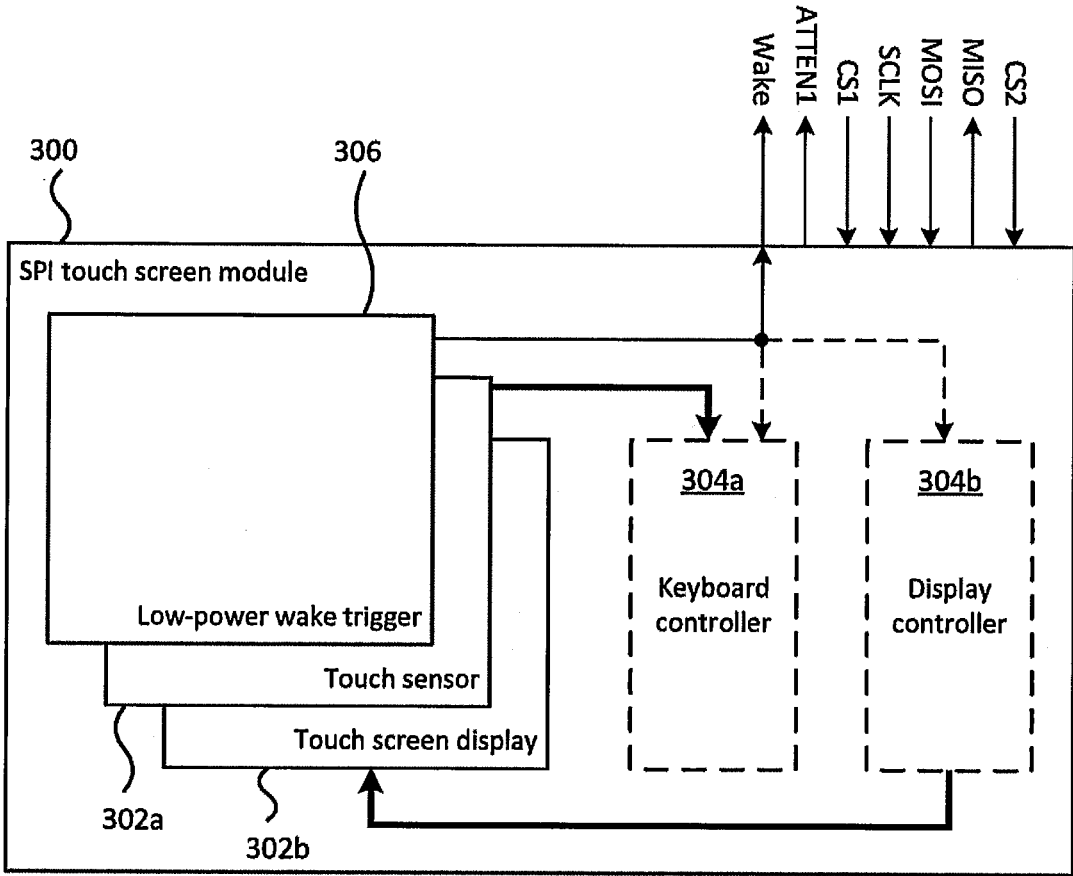

FIG. 3

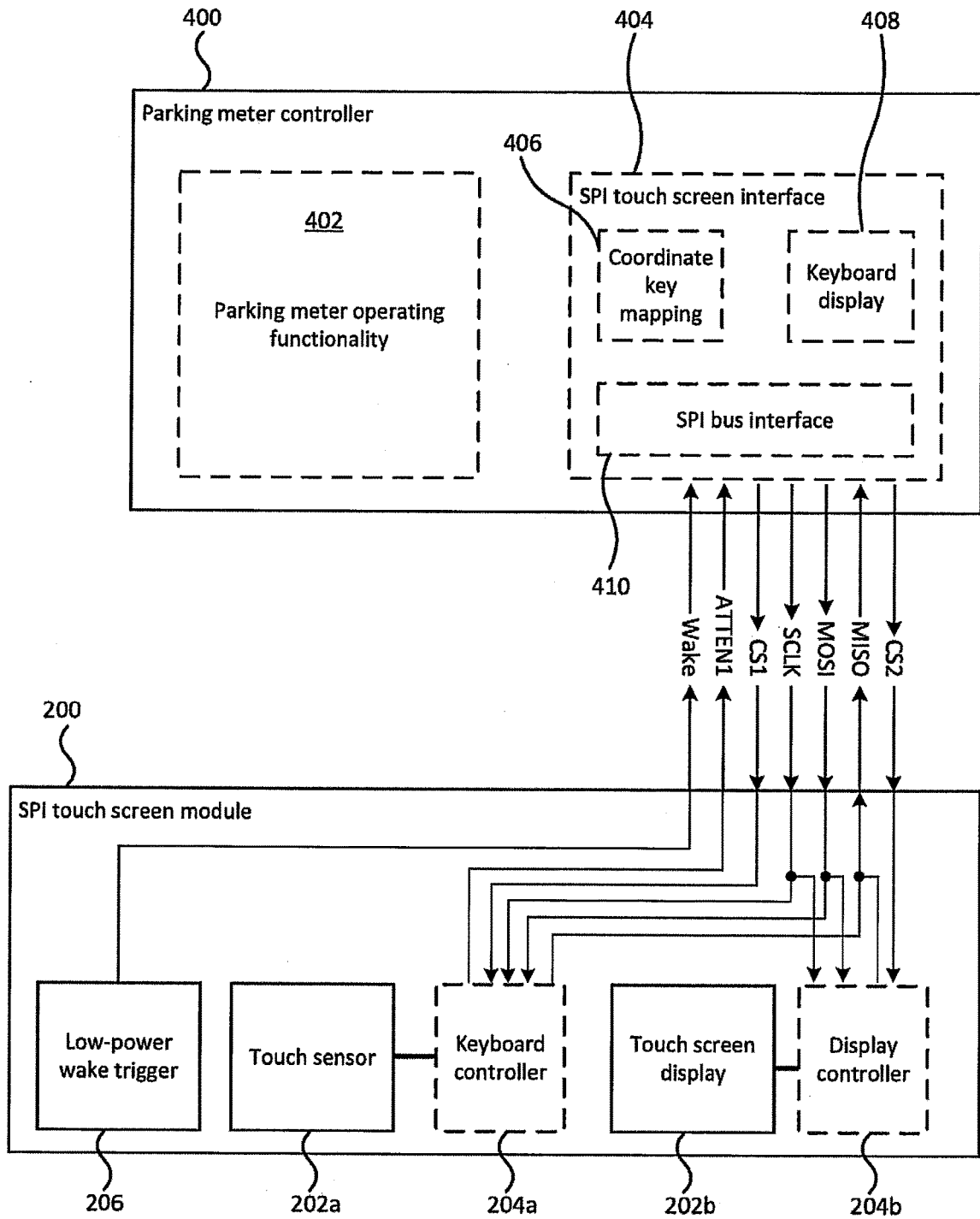

FIG. 4

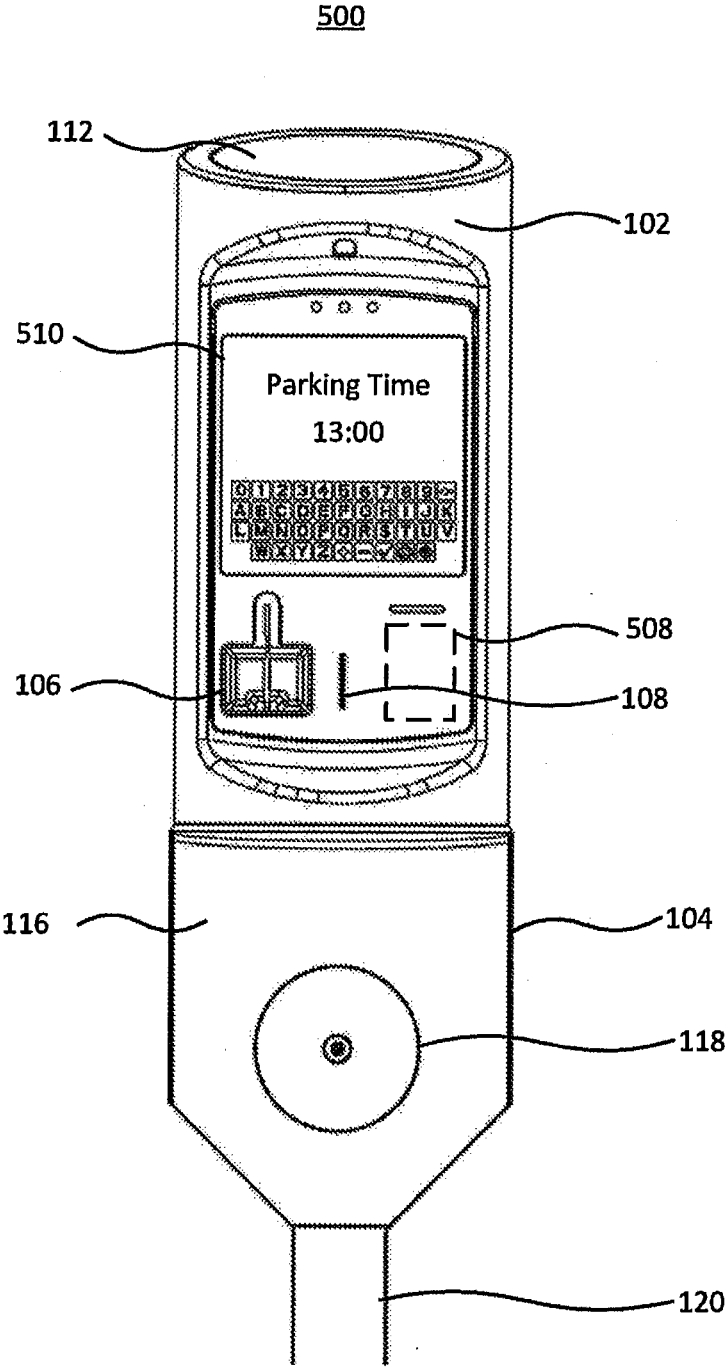

FIG. 5

600

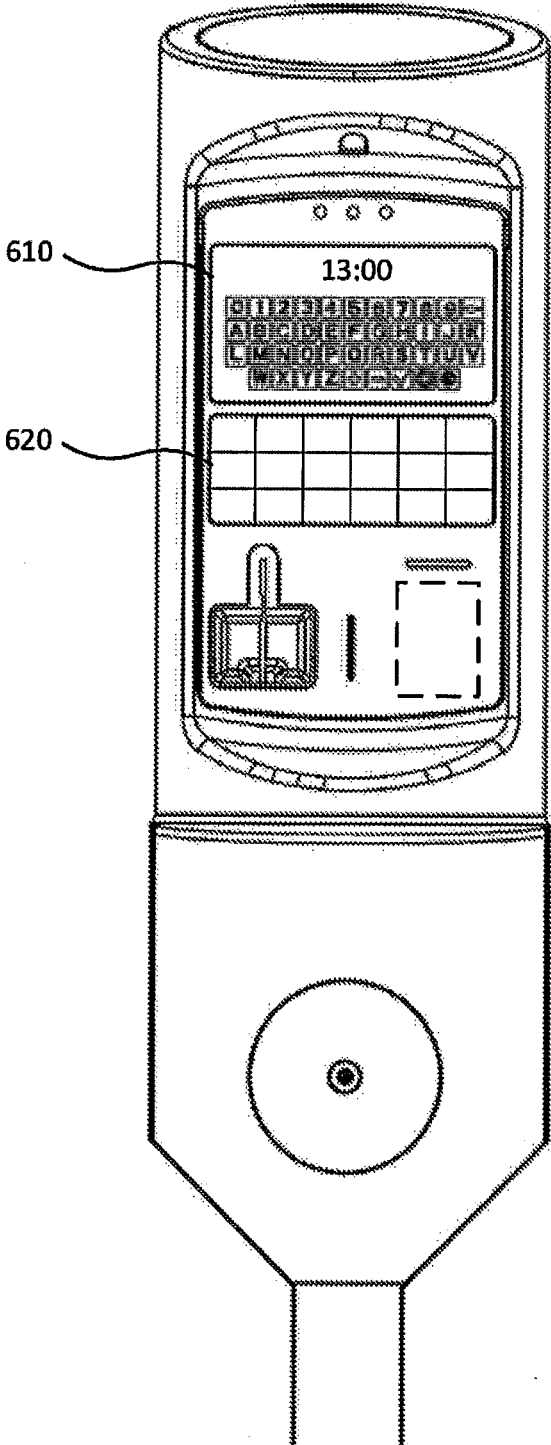

FIG. 6

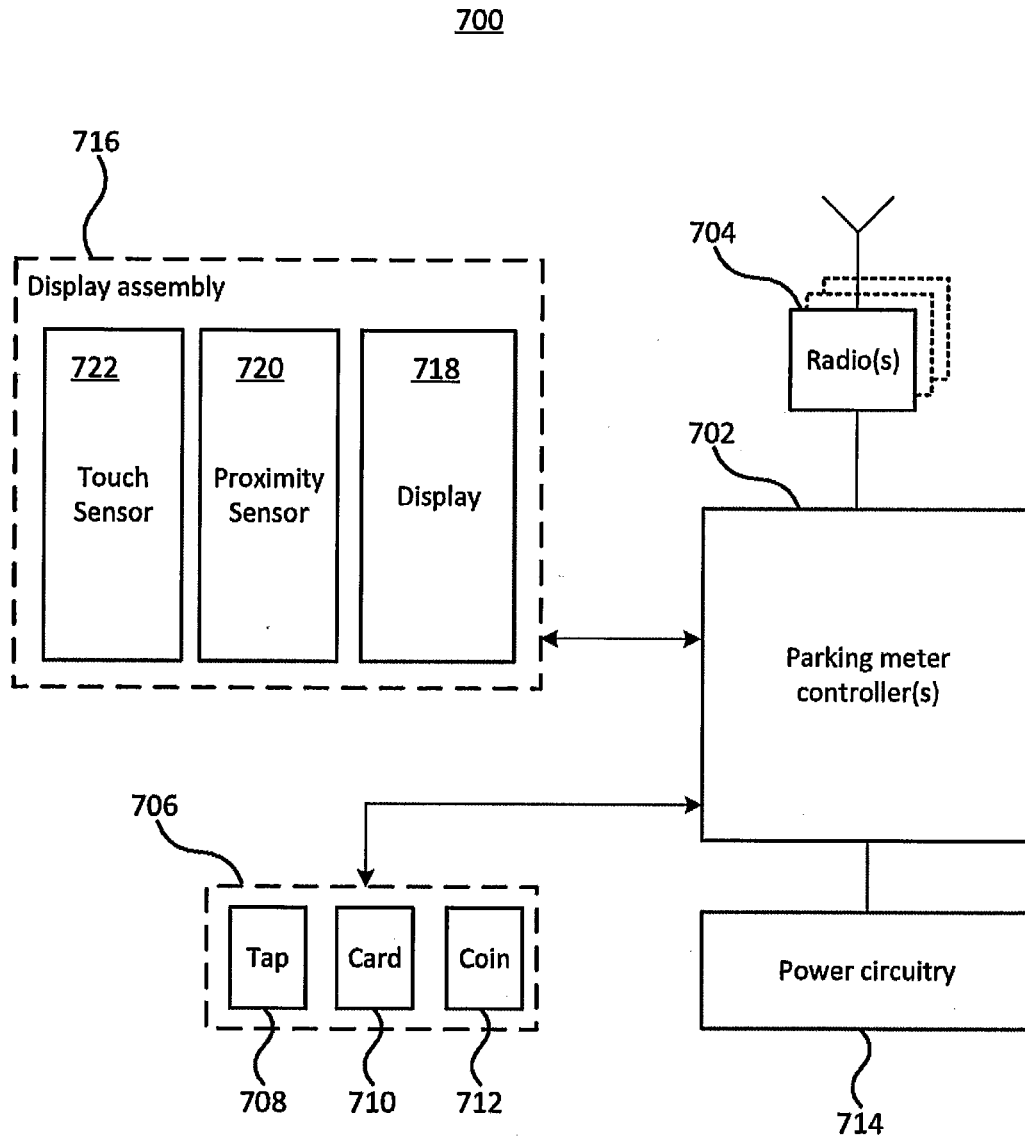

FIG. 7

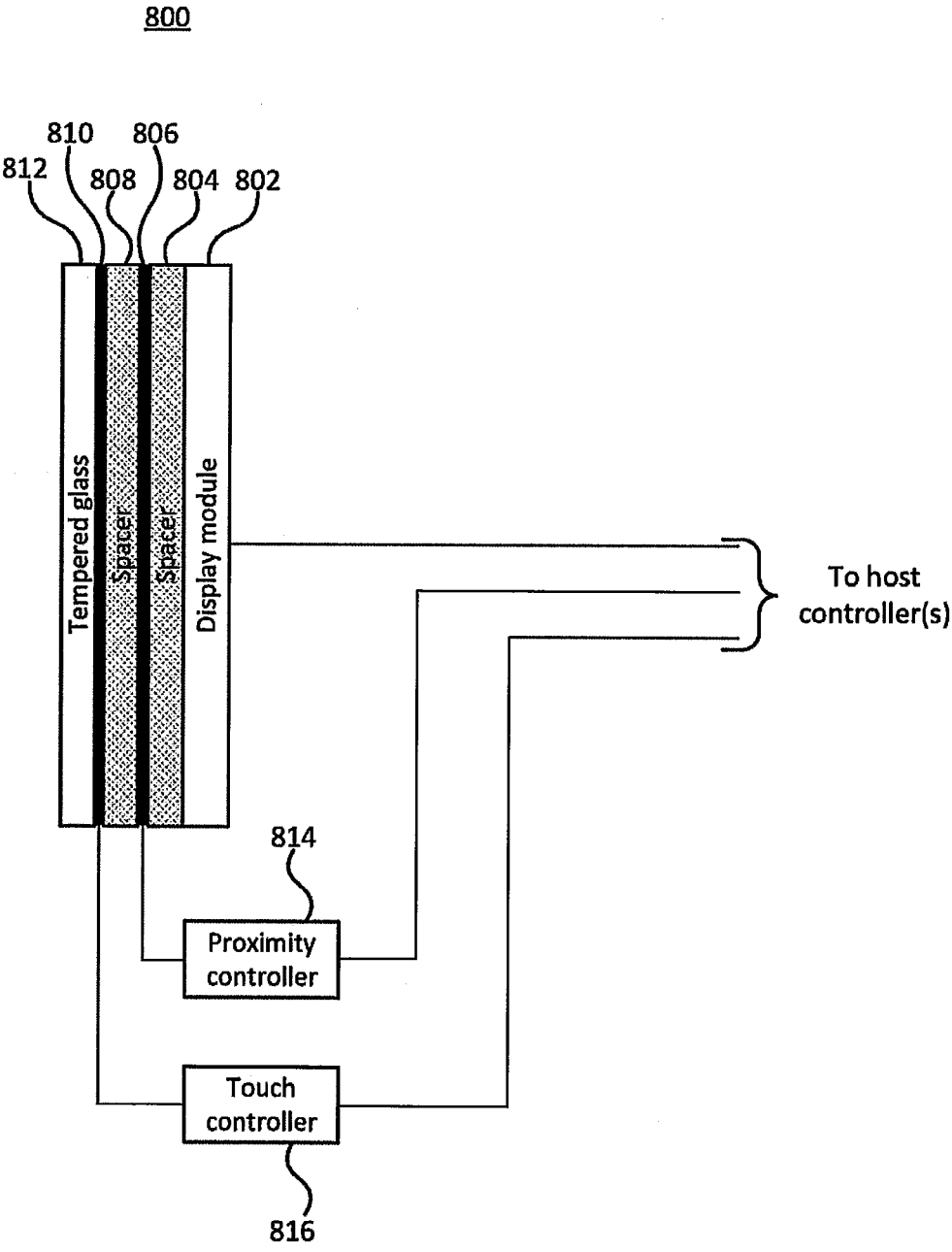

FIG. 8

900

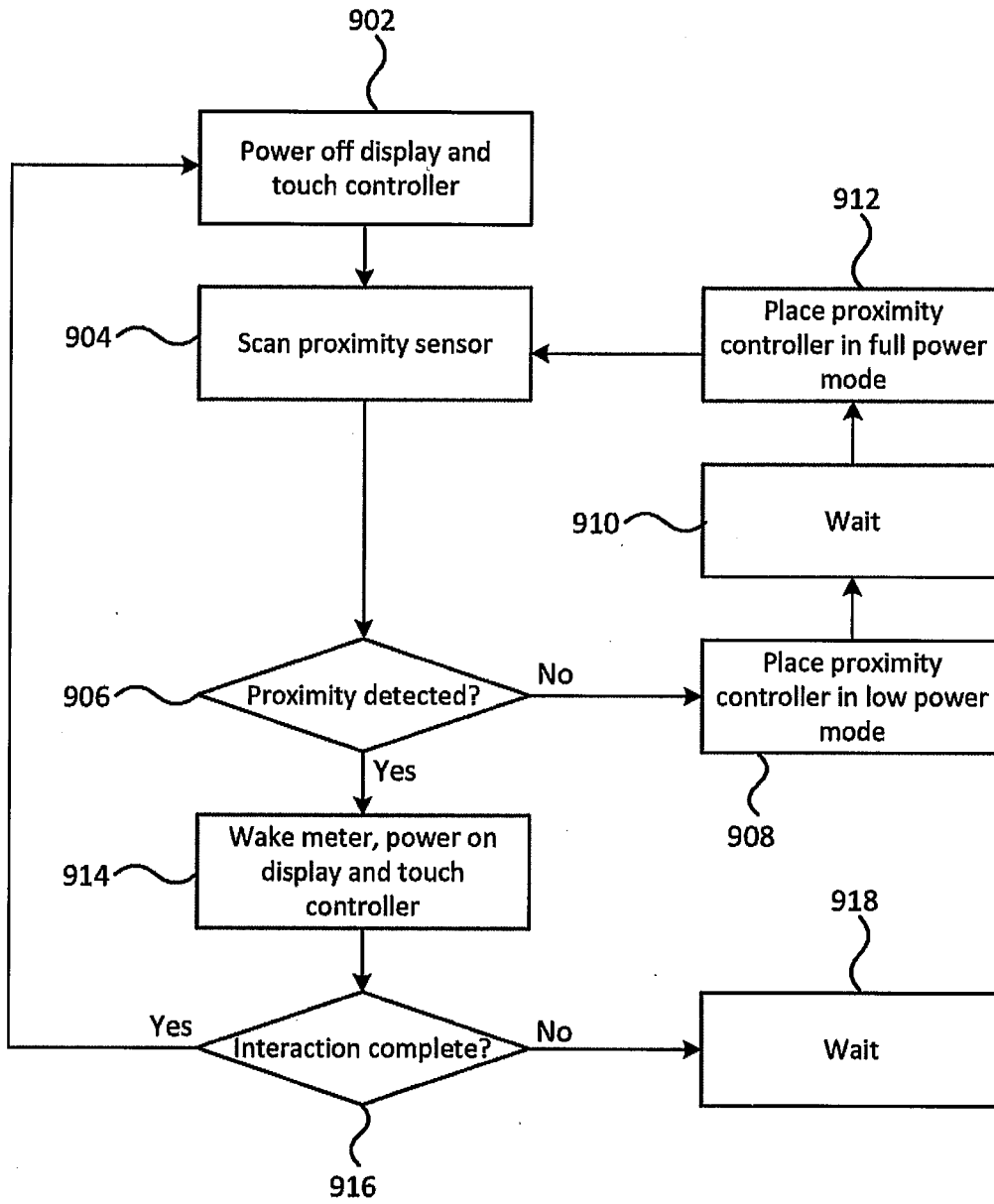

FIG. 9

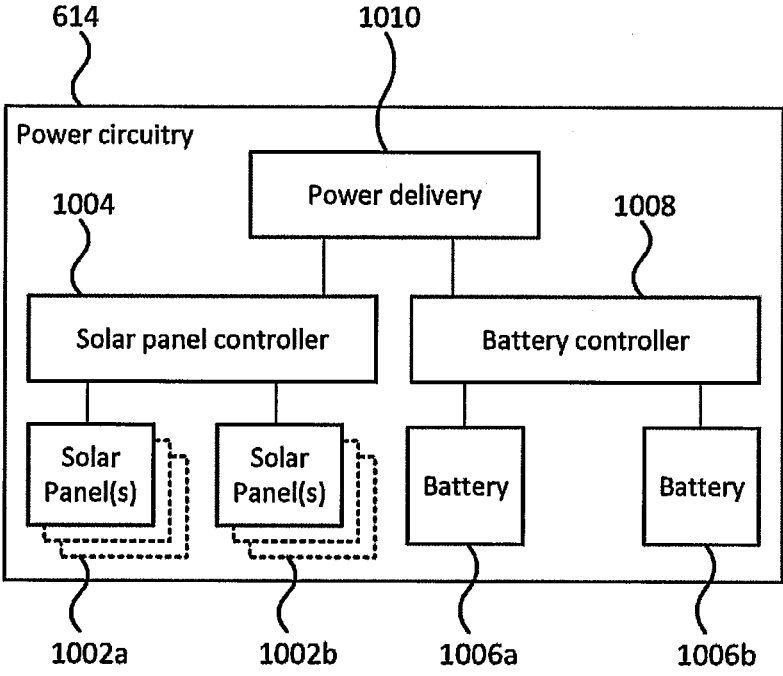

FIG. 10

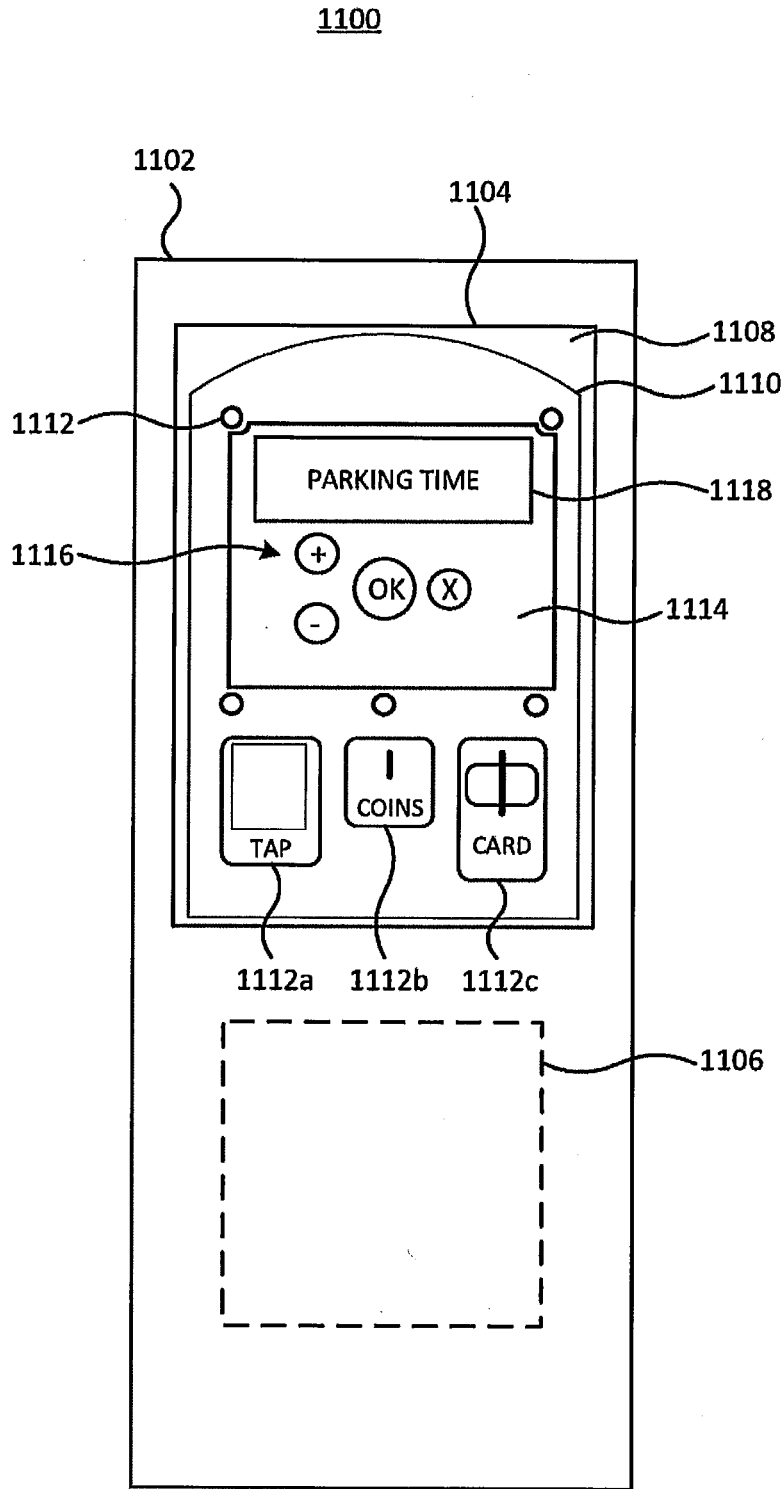

FIG. 11

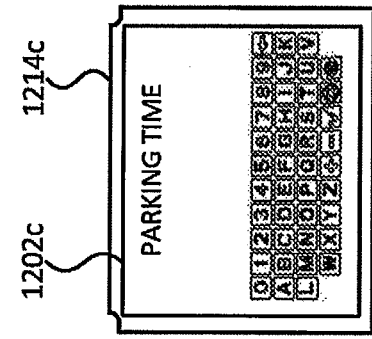

FIG. 12A

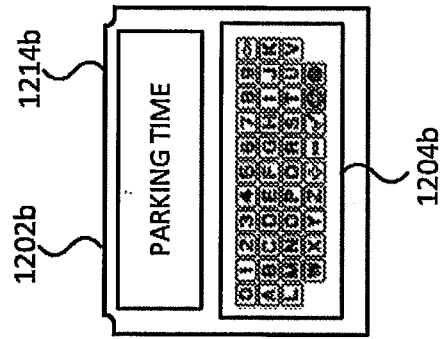

FIG. 12B

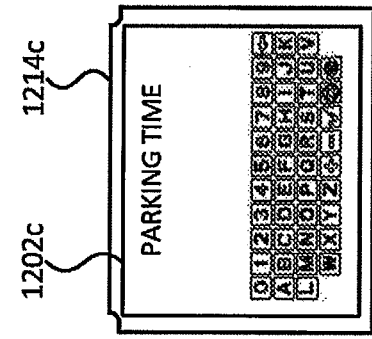

FIG. 12C

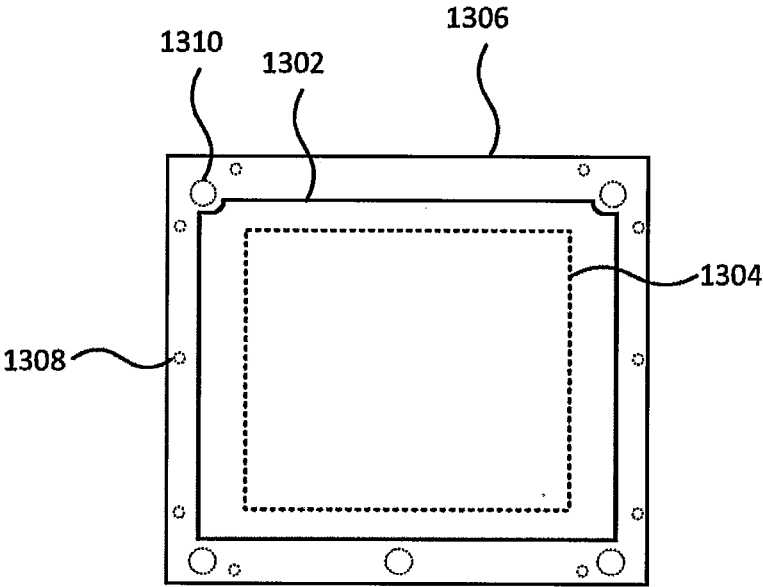

FIG. 13A

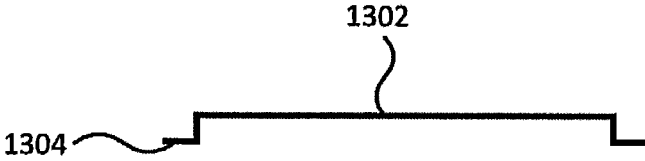

FIG. 13B

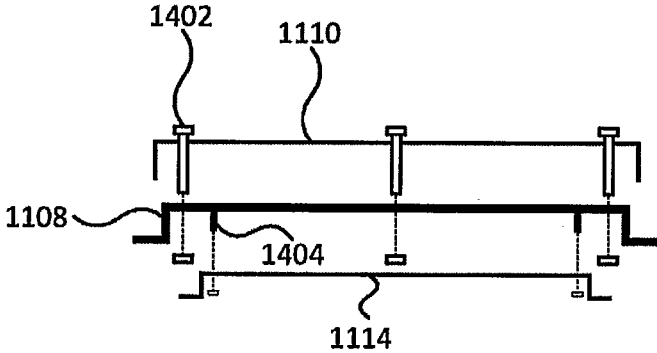

FIG. 14

PARKING METER HAVING TOUCHSCREEN DISPLAY

RELATED APPLICATIONS

[0001] The current application is a Continuation of U.S. patent application Ser. No. 17/005,479, filed Aug. 28, 2020, which is a Continuation-In-Part of Ser. No. 16/774,099, filed Jan. 28, 2020, which claims priority to Canadian patent application 3,031,936 filed Jan. 30, 2019, all of which are incorporated herein by reference in their entirety for all purposes.

TECHNICAL FIELD

[0002] The current disclosure relates to parking meters and in particular to parking meters incorporating touchscreens.

BACKGROUND

[0003] Parking meters can be classified as either a multi-space meter or a single space meter. Multi-space meters are generally larger and are used to manage payment for park time at a large group of parking spaces such as a parking lot or street block. Multi space meters tend to have sufficient space to include larger cash vaults, large batteries as well as large solar panels. Alternatively, Multi-space meters may be connected to an electrical grid. Single space meters are generally smaller meters, typically found at on street parking spots. Single space parking meters tend to be significantly smaller than multi space meters and as such may have limited space for cash vaults, batteries and solar panels. Although referred to as single space meters, they are capable of monitoring additional parking spaces. For example, it is common to provide a single space parking meter to monitor two parking spaces.

[0004] Alphanumeric keypads have been provided in multi space parking meters. However due at least in part to space restrictions they have not been used in single space parking meters.

BRIEF DESCRIPTION OF THE DRAWINGS

[0005] Features, aspects and advantages of the present disclosure will become better understood with regard to the following description and accompanying drawings in which:

[0006] FIG. 1 depicts a single space parking meter incorporating an SPI keyboard module;

[0007] FIG. 2A depicts parking meter components and an alphanumeric SPI keyboard module;

[0008] FIG. 2B depicts parking meter components and a 6-key SPI keyboard module;

[0009] FIG. 3 depicts an SPI touch screen module;

[0010] FIG. 4 depicts parking meter components of a further parking meter incorporating the SPI touch screen module of FIG. 3;

[0011] FIG. 5 depicts a parking meter incorporating a touchscreen display assembly;

[0012] FIG. 6 depicts a parking meter incorporating a touchscreen display assembly and an additional solar panel;

[0013] FIG. 7 depicts components of parking meter incorporating a touchscreen display assembly;

[0014] FIG. 8 depicts components of a touchscreen display assembly;

[0015] FIG. 9 depicts a method of controlling the touchscreen display assembly;

[0016] FIG. 10 depicts power circuitry components of a parking meter incorporating a plurality of solar panels;

[0017] FIG. 11 depicts a parking meter providing an easily retrofitted user interface;

[0018] FIGS. 12A-12C depict retrofitted user interfaces of the parking meter of FIG. 11;

[0019] FIGS. 13A and 13B depict a top view and front view of an insert plate for a parking meter with an easily retrofitted user interface; and

[0020] FIG. 14 depicts assembly of the easily retrofitted user interface of the parking meter of FIG. 11.

DETAILED DESCRIPTION

[0021] In accordance with the present disclosure there is provided a parking meter comprising: a meter housing; metering components within the meter housing, the metering components including a touchscreen assembly comprising: a display; a touch sensor overlaid on the display; and a low-power wake trigger.

[0022] In a further embodiment of the parking meter, the metering components comprise at least one controller configured to turn on the display of the touchscreen assembly when the low-power wake trigger provides a wake signal.

[0023] In a further embodiment of the parking meter, the low-power wake trigger comprises a secondary touch sensor overlaid on the touch sensor, wherein the secondary touch sensor is capable of providing an indication that a touch occurred without providing coordinates of the touch.

[0024] In a further embodiment of the parking meter, the metering components comprise at least one controller configured to turn on the display of the touchscreen assembly when a user's proximity is detected by the proximity sensor and turn off the display of the touchscreen assembly after an inactivity period of time.

[0025] In a further embodiment of the parking meter, the at least one controller is further configured to turn on the touch sensor when the display is turned on and turn off the touch sensor when the display is turned off.

[0026] In a further embodiment of the parking meter, the metering components further comprise a solar panel attached at a first location of the parking meter.

[0027] In a further embodiment of the parking meter, the metering components further comprise an additional solar panel attached at a second location of the parking meter.

[0028] In a further embodiment of the parking meter, the metering components further comprise a solar panel controller for controlling operation of the solar panel and additional solar panel.

[0029] In a further embodiment of the parking meter, the solar panel controller independently controls the solar panel and additional solar panel.

[0030] In a further embodiment of the parking meter, the solar panel controller controls the solar panel and additional solar panel using maximum power point tracking functionality.

[0031] In accordance with the present disclosure there is provided a parking meter comprising: metering components; an insert housing comprising one or more openings for receiving respective user interface components; an external housing component enclosing the metering components, the external housing component comprising: at least one opening for a payment device; and at least one cutout for receiving the insert housing, wherein the insert is secured within the cutout of the external housing component.

[0032] In a further embodiment of the parking meter, the parking meter is a multi-space parking meter and the external housing component comprises a door panel of a cabinet of the multi-space parking meter.

[0033] In a further embodiment of the parking meter, the insert comprises a plurality of openings including a first opening for a display and a second opening for a keyboard or keypad, wherein the metering components include the display and keyboard or keypad.

[0034] In a further embodiment of the parking meter, the insert comprises a single opening for a touchscreen display, wherein the metering components include the touchscreen display.

[0035] In a further embodiment of the parking meter, the touchscreen display is part of a touchscreen display assembly comprising the touch screen display and a proximity sensor, wherein the proximity sensor turns on the touchscreen display when a user's proximity is detected.

[0036] In a further embodiment of the parking meter, the insert is secured within the cutout by bolts secured to an inside of the external housing.

[0037] In a further embodiment of the parking meter, the parking meter is a single space parking meter.

[0038] In accordance with the present disclosure there is further provided an SPI touch screen module for connection to a parking meter controller in a parking meter by an SPI bus, the SPI touch screen module comprising: a touch screen display; a touch sensor overlaid on the touch screen; a display controller configured to: receive display information from the parking meter controller; and display at least one virtual key on the touch screen display according to the received display information; and at least one keyboard controller configured to: detect a touch at a location on the touch sensor; and transmit over the SPI bus an indication of the location on the touch sensor of the detected touch to the keyboard interface of the parking meter controller.

[0039] Single space parking meters and multi space parking meters can be used by different companies, cities, governments, etc., referred to as operators for brevity, for monitoring parking spaces. Different operators may have different requirements for their parking meters and as such parking meter designs are often modified to suit the different needs of the different operators. A parking meter keyboard module is described further below that provides flexibility in using different keyboard layouts. Different keyboard modules can be used without requiring significant changes to the underlying parking meter control. The keyboard modules also can provide low power consumption making them well suited for use in single space parking meters.

[0040] FIG. 1 depicts a single space parking meter incorporating an SPI keyboard module. The parking meter 100 has an upper portion 102 that is secured to a lower portion 104. The upper portion houses the main components of the parking meter 100. While the particular components may vary from meter to meter they may include a payment means such as a card reader 106 for reading payment cards as well as a coin slot 108 for accepting coins. The parking meter includes a display 110 for displaying information such as instructions, parking time purchased, time remaining etc. A solar panel 112 may be positioned on the parking meter 100 and may provide power to the parking meter to charge a battery in order to extend an operating life of the parking meter. In addition to the payment means, display and solar panel, the parking meter includes a keyboard 114. As

depicted in FIG. 1, the keyboard 114 may be an alphanumeric keyboard including all of the letters 'A' to 'Z', the number 0 to 9 as well as additional keys such as a plus key, a minus key, an 'OK' key, a cancel key and a language key. As described in further detail below, the keyboard 114 is provided by a serial peripheral interface (SPI) keyboard module. The SPI keyboard module allows different keyboard layouts to be used without requiring further changes to the parking meter components. An SPI keyboard interface provided by, for example, the main parking meter controller is able to communicate with different SPI keyboard modules regardless of the keyboard layouts, and determine keys that have been pressed. In addition to providing easy flexibility for using different keyboard layouts, the SPI keyboard module can provide low power consumption, making it well suited for use in single space parking meters that may have limited space for batteries.

[0041] The keyboard 114 allows a user to input various information into the parking meter 100. For example, the keyboard 114 may be used to provide pay-by-space functionality or pay-by-plate functionality, both of which are common to multi-space meters. Pay-by-space functionality allows a user to pay for a particular parking spot that is associated with an identifying number by entering the number into the parking meter and purchasing the desired amount of time. Pay-by-plate functionality allows a user to purchase parking time that is associated with a license plate or vehicle identification number (VIN) by entering the license plate or last few digits of the VIN into the parking meter and purchasing the desired amount of parking time. Additional functionality may be provided that makes use of the keyboard 114. For example, a user could enter a telephone number in order to receive notifications of expiry of the purchased parking time or an e-mail address to receive a payment receipt.

[0042] The upper portion of the parking meter 102 is secured to the lower portion 104. The lower portion comprises a vault 116 for coins inserted into the coin slot 108. The vault 116 may have a vault door 118 for removal of the collected coins. The vault 116 can be secured to a post 120 or other structure that secures the parking meter 100 in a desired location.

[0043] FIG. 2A depicts parking meter components and an alphanumeric SPI keyboard module. The parking meter 200a comprises main parking meter components 202, an SPI keyboard module 204a connected to the parking meter components by an SPI bus 206. The main parking meter components include at least one processor or controller, depicted as CPU 208, that executes instructions stored in memory 210. The parking meter components may further include a physical connection 212 to the SPI bus. When the instructions stored in the memory 210 are executed, they configure the parking meter components 202 order to provide various functionality 214 to the parking meter. The functionality 214 includes operating functionality 216, which broadly provides the parking meter functions, for example the timing functionality, purchasing functionality, communication functionality, etc. It will be appreciated that the operating functionality may include a wide variety of different functionality which is not described in detail. Regardless of the particular operating functionality, it is necessary to provide user input to the operating functionality, for example in order to allow a user to specify a desired amount of time to purchase. The user input may include

further input for example to control, review, or set operating parameters of the parking meter.

[0044] The functionality **114** further includes SPI keyboard interface functionality **218** that communicates with the SPI keyboard module **204a** over the SPI bus **206**. The SPI keyboard interface functionality **218** receives an indicator of a particular key that was pressed and maps the indicator to a key which is communicated to the operating functionality **216**. For example, the SPI keyboard interface functionality **218** may receive an indicator of '15' over the SPI bus **206** indicating that key number **15** was pressed. The SPI keyboard interface functionality **218** maps the received indicator to a key of the keyboard, for example '15' may be mapped to a key 'e'. The particular mapping used by the SPI keyboard interface **218** for mapping an indicator to a key may change depending upon the keyboard used.

[0045] FIG. 2B depicts parking meter components and a 6-key SPI keyboard module. The parking meter **200b** is substantially the same as parking meter **200a** except that a different SPI keyboard module **204b** is connected to the SPI bus **206**. The SPI keyboard module **204b** layout is significantly different from that of the alphanumeric SPI keyboard module **204a** and comprises 6 keys. Although the SPI keyboard module **204b** has a significantly different layout from that depicted in FIG. 2A, the parking meter components **202** and in particular the operating functionality **216** and the SPI keyboard interface functionality **218** remains the same as described above for parking meter **200a**. In order to operate correctly with the different keyboard layout depicted in FIG. 2B, the mapping used by the SPI keyboard interface **218** to map a received indicator to a key is selected for the particular keyboard. The mapping may be loaded into the SPI keyboard interface functionality during a manufacturing stage, an assembly stage, a setup or configuration stage or during an in-use stage while the parking meter is installed in the field. The mapping may be loaded manually at the meter by a technician, or the mapping may be loaded automatically based on the particular SPI keyboard module connected to the parking meter components. Additionally or alternatively, the meter may have the ability to establish a communication channel with a remote management server or a mobile data source to automatically request and download the correct mapping data corresponding to the connected SPI keypad from that remote management server or mobile data source. The SPI keyboard interface functionality **218** allows different keyboard layouts to be used with minimal changes, if any, to the operating functionality, as well as minimizing manual intervention at the meter by a technician.

[0046] The above has described an SPI keyboard module that provides flexibility in laying out the physical keys of the keyboard. As described further below, rather than using physical keys, a virtual keyboard may be provided in a similar manner by an SPI touch screen module.

[0047] FIG. 3 depicts an SPI touch screen module. An alternative low power SPI implementation of a virtual keyboard may be implemented using a touch screen over a display screen. Touch screen technology is quite common, and virtual keyboards can be created with a touch screen overlaid onto the display with visual "keys" placed at specific locations on the display. However in low power applications such as battery powered parking meters, having both the display and the touch screen technology always active consumes a lot of power and is not practical. Some solutions to this incorporate a single "wake up" button

adjacent to the screen that allows the touch screen to be turned on. While the adjacent switch or button provide an effective solution for conserving power, the additional requirement of having to press the adjacent button to power on the touch screen provides a less-than desirable user experience.

[0048] The SPI touch screen module **300** comprises a touch sensor **302a** overlaying a touch screen display **302**. The touch sensor **302** may provide input to a keyboard controller **304a** and the touch screen display **302b** may be controlled by a display controller **304b**. Both the keyboard controller **304a** and display controller **304b** may communicate with a parking meter controller (not shown) over an SPI bus interface. As depicted, the SPI bus interface may include different chip select lines, CS1 and CS2, for the keyboard controller and the display controller. Alternatively, a single CS line may be provided with the keyboard controller data being provided to the parking meter over the MISO line while the display controller receives display information, such as what to display, from the parking meter controller over the MOSI line.

[0049] In addition to touch sensor **302a** and the touch screen display **302b**, the SPI touch screen module may further include a low-power wake trigger **306**. The low-power wake trigger **306** may be provided by for example as a secondary touch sensor overlaid on top of the touch sensor and the touch screen. The secondary touch sensor may only be required to provide an indication of whether a touch occurred, rather than also providing an indication of the coordinates of one or more touches. The low-power wake trigger **306** can provide a wake signal to the parking meter controller (not shown) providing an indication that the touch screen display of the SPI touch screen module should be powered on or woken up. Additionally or alternatively, the wake signal may be provided to one or both of the keyboard controller **304a** and display controller **304b**.

[0050] Although depicted as an overlay on top of the touch sensor and touch screen display, the low-power wake trigger **306** may be provided in other ways. For example a vibration sensor may be attached to the touch sensor and/or touch screen display to allow detection of vibrations caused by a user pressing or tapping on the screen. Additionally or alternatively, a piezo electric element or switch may be physically associated with the touch screen to detect an initial press on the touch screen. By incorporating an additional touch or vibration sensitive technology into the traditional touch screen solution, an initial finger press or touch anywhere on the touch screen display of the SPI touch screen module can be used as an initial wake up mechanism. Upon waking up, the touch screen display with touch sensor may become active. The combination of the touch screen with the low power wake trigger associated with the touch screen, conserves power as it allows the initial lower power touch or vibration sensor to trigger the system to wake up or provide an interrupt, which allows the higher powered virtual keyboard utilizing a touch sensor and touch screen display to become active and available to use.

[0051] FIG. 4 depicts parking meter components of a further parking meter incorporating the SPI touch screen module of FIG. 3. The SPI touch sensor module **300** is depicted as being connected to the parking meter controller **400** via an SPI bus interface that includes the shared Serial Clock (SCLK) line, Master Out Slave In (MOSI) line, and Master In Slave Out (MISO) line. The SPI bus interface is

depicted as further including respective chip select (CS1, CS2) lines for the keyboard controller and display controller respectively, an attention (ATTEN1) line providing an indication that a key press, or rather a touch screen press, is ready to be transmitted, and a wake (Wake) line providing an indication to the parking meter controller 400 that the touch screen display has been touched or pressed.

[0052] The parking meter controller 400 may comprise parking meter operating functionality 402 as well as SPI touch screen interface functionality 404. The SPI touch screen interface functionality 404 is similar to the SPI keyboard interface functionality described above. While the SPI keyboard interface functionality maps a key switch that was pressed to a corresponding key using a particular key map associated with the particular SPI keyboard module, the SPI keyboard interface functionality maps a screen location that was pressed to a corresponding key using a coordinate key mapping 406 associated with the particular screen displayed on the touch screen display 302. The SPI touch screen interface functionality may include keyboard display functionality 408 that may interact with the parking meter operating functionality 402 in order to display, or more particularly cause the SPI touch sensor module to display, an appropriate virtual keyboard screen, or other appropriate or desired screen. Information about the location of displayed keys may be provided to both the keyboard display functionality 408 and the coordinate key mapping functionality 406 in order to map a press on the touch sensor to a particular key displayed at the pressed location. The indication of the pressed location as well as the display information may be transmitted between the SPI touch sensor module 300 and the parking meter controller 400 over the SPI bus interface. As described above, a wake signal may be provided to the parking meter controller from the low power wake trigger 306 on the SPI touch sensor module. The wake signal may also be provided to the display controller 304b and possibly the keyboard controller 304a. Upon receiving the wake signal from low-power wake trigger 306, the parking meter controller 400 determine what should be displayed on the touch screen display 302b and transmit the appropriate data to the SPI touch sensor module to 300 using the SPI bus interface functionality 406 to cause the SPI touch sensor module to display the screen on the touch screen display.

[0053] The touch sensor 302a and keyboard controller 304a of the SPI touch sensor module 300 may send an indication of a pressed location on the touch sensor 302a overlaying the touch screen display in a similar manner that the keyboard controller of the SPI keyboard module described above sends an indication of the pressed key switch to the parking meter controller. In particular, the keyboard controller may set the signal on the ATTEN1 signal line to indicate to the parking meter controller that touch data is available for transmission. When the CS1 line signal is set, the location information indicating the location of the press or touch on the screen may be transmitted over the MISO signal line.

[0054] The SPI touch screen module described above provides a touch screen keyboard connected to the parking meter controller via an SPI interface which may behave substantially as a keyboard. The SPI touch screen keyboard may also include a low-power wake trigger that provides a wake signal that may be used to wake of the meter, including powering on the display of the touch screen keyboard. As

described further below, a parking meter may use a touch screen display for both the user interface display as well as providing a virtual, or touch, keyboard.

[0055] It may be desirable to incorporate a touchscreen display into a parking meter, however the power requirements for a large display may be relatively large for use in a parking meter that is powered by batteries and/or solar panels. In order to reduce the power requirements of the touchscreen display, a wake trigger may be used to turn the display on when a user is detected, for example based on a detected touch or user's proximity. The touch screen display may provide the parking meter with a graphical user interface, allowing other user interface components, such as other keypads, keyboards, and/or buttons to be eliminated from the parking meter. Accordingly, the touchscreen display may be used to provide a parking meter having a smaller footprint. Additionally or alternatively, the eliminated interface components may provide space for additional components such as additional solar panels for powering the meters. Further, the touchscreen display may provide a flexible graphical user interface allowing the same parking meter to provide various different parking meter functionality, such as pay and display functionality, pay by space functionality, and/or pay by plate functionality. While touchscreen displays may be desirable in certain applications, it may also be desirable to provide a parking meter that is initially provided with a non-touchscreen user interface that can be easily upgraded or retrofitted with a touchscreen display, an alternative display or other user interfaces.

[0056] FIG. 5 depicts a parking meter incorporating a touchscreen display assembly. The parking meter 500 is similar to the parking meter 100 described above, however rather than incorporating an SPI touchscreen keyboard module and a separate display, the parking meter 500 uses a touchscreen display assembly. Similar to the parking meter 100, the parking meter 500 has an upper portion 102 that is secured to a lower portion 104. The upper portion houses the main components of the parking meter 100. While the particular components may vary from meter to meter they may include a payment means such as a card reader 106 for reading payment cards as well as a coin slot 108 for accepting coins as well as a tap or NFC sensor 508 for contactless payment readers, as well as a solar panel 112. The parking meter 500 incorporates a single large touchscreen display 510 that provides a user interface for both displaying information to the user as well as receiving input from the user. In order to provide an energy efficient display, the touchscreen 510 may incorporate a low-power wake trigger similar to that described above with regard to the SPI touchscreen keyboard. Further, as described further below with reference to FIG. 7, the low-power wake trigger may be provided by a proximity sensor that is capable of sensing the proximity of a user to the touchscreen display 510. In order to conserve energy, the meter 500 may power off, or place into a low power mode, the display and the touch sensor of the touchscreen, after a period of inactivity has occurred. The meter may continue to operate the low-power wake trigger or proximity sensor in order to detect a user interaction with the meter and power on, or place into a wake mode, the display and touch sensor as well as other components of the parking meter.

[0057] The upper portion 102 may be secured to a low portion 104 that includes a coin vault 116 with a lockable vault door 118 that can be secured to a post 120 or other

structure at a parking meter location. The coin vault may be removed if it is not required to accept coin payments. Although described as being a single space meter, the meter 500 may be configured to meter multiple parking spaces. In general, multi-space meters have a larger coin vault compared to single space parking meters, however if coins are not required or if the number of coins required to be handled is low, the coin vault 116 of the single space parking meter may be sufficient to handle to metering of multiple spaces typically handled by a multi-space style meter. Multi-space meters may also incorporate a printer in order to provide pay-and-display metering functionality. However, with the touchscreen display 510 capable of providing an alphanumeric interface, the single space style meter 500 may provide a pay-by-space or pay-by-plate meter capable of metering multiple spaces.

[0058] FIG. 6 depicts a parking meter incorporating a touchscreen display assembly and an additional solar panel. The parking meter 600 is similar to the parking meter 500 described above that incorporates a large touchscreen display 510. Incorporating a touchscreen display into the parking meter may provide flexibility in the user interface. As depicted, the parking meter 600 may incorporate a smaller touchscreen display 610 compared to the touchscreen display 510. Incorporating a smaller touchscreen display 610 may provide more space on the exterior of the parking meter, which may allow additional components to be included in the parking meter. For example, as depicted the parking meter unit which may be secured to the coin vault or post, may incorporate an additional solar panel 620. While parking meters have previously incorporated solar panels, the solar panels have typically been located at a single location on the parking meter. As depicted in FIG. 6, multiple solar panel locations may be provided in a single space removable parking meter unit. Single space parking meters may be installed in a wide variety of locations and orientations, some of which may have a single solar panel location shaded and as such provided reduced power output. Accordingly, having multiple locations of solar panels may result in improved power output across different installation locations. The additional solar panels may be located in various different locations on the parking meter. Additionally, as described further below with reference to FIG. 10, the multiple solar panels may be independently controllable so that each individual solar panel may operate at its optimal operating parameters.

[0059] Although described above as using additional space for a solar panel 620, it is possible to incorporate other parking meter components into the parking meter with a touchscreen display. For example a printer, which may be used for pay-and-display style metering, could be incorporated into the parking meter.

[0060] FIG. 7 depicts components of parking meter incorporating a touchscreen display assembly. The parking meter components 700 may provide a parking meter as described above with reference to FIG. 5 or FIG. 6. The components 700 may include one or more parking meter controller(s) 702. The parking meter controller(s) may be one or more of, for example, microcontrollers, microprocessors, central processing units (CPU), application specific integrated circuits (ASIC), field programmable gate arrays (FPGA) or other types of controllers. The controller(s) 702 may provide various functionality for the parking meter, including controlling the user interface, metering functionality, payment

information, remote communications, power control, etc. When multiple controllers 702 are used, the controllers may communicate with each other using one or more interfaces such as SPI, I2C, USB™, HDMI™, or other types of interfaces. The components 700 may further include one or more radio(s) 704 including for example, WiFi™ radios, cellular radios, Bluetooth™, etc. The radios may be used to communicate with external devices, which may include other parking meters, external sensors such as parking spot occupation sensors, in-car payment devices, mobile phones, remote servers, etc. The radios 704 may be used to provide various features such as remote reporting and monitoring of parking meters as well as remote payment for parking.

[0061] The components 700 may further include one or more payment devices 706. The payment devices 706 may include for example one or more of a tap or contactless payment reader 708, a payment card reader 710 and/or a coin chute 712. Other payment may be possible such as paying over Bluetooth or cellular connections. The components 700 may further include power circuitry 714 used for powering the meter components 700. The power circuitry will depend upon how the meter is powered, such as by a mains connection, battery powered, and/or solar panels.

[0062] The components 700 further include a touchscreen display assembly 716. The display assembly 716 may comprise a display 718 which may be provided using various different technologies, a proximity sensor 720 that can detect a proximity of a user or user's finger to the display assembly, and a touch sensor 722 that can determine a coordinate of a user's touch. The proximity sensor 720 may use, for example, a low frequency, low power electrical near-field (E-Field) sensing components and control components to detect the approach and presence of a user or a user's hand/finger(s). The proximity sensor 720 and touch sensor 722 may be overlaid over the display to provide the touch screen assembly 716. The display assembly 716 may include one or more controllers of the parking meter controllers which may power down the display and touch sensor after a period of inactivity has passed and then turn the display and the touch sensor on when proximity of a user is detected by the proximity sensor 720. Other parking meter components of the parking meter may also be powered down, or placed in a low power mode according to inactivity of the meter and powered up or placed in a high power mode based on detected proximity by the proximity sensor 720.

[0063] FIG. 8 depicts components of a touchscreen display assembly. The display assembly 800 may be used as the touchscreen display assembly 716. The display assembly 800 comprises a display module 802 which may be for example a monochrome or color display using various display technologies, including for example an LCD panel, LED panel, OLED panel, e-ink panel, or other possible technologies. The display module 802 may include the display panel as well as interface circuitry for connecting the display module to the parking meter controller(s). A spacer material 804, which may be a plastic or glass material or other non-conductive transparent material may be sandwiched between the display module and an electrode, or electrodes 806 of the proximity sensor. The touch sensor electrode(s) 810 and proximity electrode(s) 806 may be provided as one or more layers of thin conductive traces and/or by a transparent conductive material with the conductive layers separated by a thin layer of insulating material. The electrode(s) 806, 810 may be transparent, or near

transparent so that they can be overlaid directly over the display without significantly impacting the visibility of the display. An additional spacer material **808**, which may be the same or different from the spacer material **804**, is sandwiched between the proximity electrode(s) **806** and electrode(s) **810** for the touch sensor. The electrodes may depend upon the technology of the touch sensor. For example, if the touch sensor uses projected capacitance the electrode(s) may comprise a pair of orthogonal matrices of conductive electrodes. The touch sensor electrodes **810** may be covered by tempered glass **812**. The tempered glass **812** may provide protection to the display assembly **800** from the external environment as well as from vandalism. The touchscreen display assembly **800** may also include a proximity controller **814** and a touch controller **816**. The proximity controller **814** is connected to the proximity electrodes **806** and can periodically scan the electrodes in order to detect a proximity of a user. The controller **814** may process the signals from the proximity electrodes **806** to detect proximity and provide an indication of the detected proximity to a host controller or the controller may pass the signals to another controller for further processing and determining if a user is in proximity. Similarly, the touch controller **816** may provide signals to, and monitor the signals from, the touch sensor electrodes **810**. The controller may process the signals from the touch sensor electrodes **810** in order to determine a location of a user's touch or may pass the signals on to another controller for determining the location of the touch.

[0064] The touchscreen display assembly may require a calibration process in order to correlate locations of the touch sensor electrodes with locations on the display. The calibration process may present location to touch on the display and the resulting touch locations registered by the touch sensor may be calibrated to overlap with the presented location.

[0065] The above has described using the proximity sensor to detect a proximity of a user and power up meter components such as the display and touch sensor based on the detected proximity. Additionally, the proximity sensor may be used to detect non-touch gestures of the user, such as swiping up, down, left, right, etc. The detected gestures may be used as user input for controlling the parking meter, such as adding or removing time, proceeding to a next or previous screen of a user interface, etc.

[0066] The proximity sensor may use a low frequency, low power E-Field sensing components and control components to detect the approach/proximity of a user, hand/finger etc. The proximity sensor may continually monitor the electrodes for proximity and then wake other metering components when the proximity is detected. While using the proximity sensor in such a manner to wake other components can provide considerable power savings, as described further below, additional power savings may be achieved by periodically scanning the proximity electrodes until a user's proximity is detected.

[0067] FIG. 9 depicts a method of controlling the touchscreen display assembly. The method **900** periodically scans the proximity sensor to detect a user's proximity in a low power way. The method **900** may begin with powering off the display and touch controller (**902**) as well powering off or down other meter components. For example, the main controller, radios payment devices or other components may be powered down to conserve energy. Once the display and

touch sensor are powered down, the periodic scanning of the proximity sensor (**904**) may begin, and if no proximity is detected by the scan (No at **906**) the proximity sensor can be placed in a low power mode (**908**) in which it is not scanning or monitoring the proximity electrodes. After powering down the proximity controller, the process waits (**910**) for a set period of time. The length of time to wait is a trade-off between power savings, that is the longer the wait the more the power savings, and usability, that is detecting the proximity of the user without a long delay. The wait time may be for example 0.1 seconds although the wait time may change based on what is acceptable for the trade-off between power and usability. After waiting for the wait time, the proximity controller is placed in the high power mode (**912**) and the proximity sensor, or electrodes, scanned (**904**) to determine if a user is in proximity. If a user's proximity is detected (Yes at **906**) the meter may be placed in a wake state and the display and touch sensor powered on (**914**). Once in the wake state the meter may present the user with a graphical user interface for interacting with the parking meter. The method determines if the interaction is complete (**916**), which may be determined based on various events, such as receiving or completing payment, or a period of time passing without there being any user activity. If the interaction is complete (Yes at **916**) the meter may be powered down or placed in a sleep state including powering off the display and touch sensor (**902**) otherwise (No at **916**) the meter may wait (**918**) until the interaction is completed.

[0068] FIG. 10 depicts power circuitry components of a parking meter incorporating a plurality of solar panels. The power circuitry **614** provides the required power to the parking meter components as well as controlling other power related functionality such as controlling operation of the solar panels as well as charging batteries. The power circuitry **614** may include a plurality of solar panels **1002a**, **1002b**. The plurality of solar panels may be arranged in a plurality of independent groups. Solar panels of one of the groups may be connected together in serial and/or parallel. The individual groups of solar panels **1002a**, **1002b** may be controlled individually by a solar panel controller **1004**. Controlling the solar panel groups individually may allow the groups of solar panels to operate at the ideal operating parameters of the solar panel group. For example, if one group of solar panels is shaded, while another group is in direct sun, the two groups may operate at different parameters to ensure each group can output its maximum amount of power instead of operating at the parameters of the shaded solar panel.

[0069] The solar panel controller **1004** may control each independent grouping of solar panels using, for example, maximum power point tracking (MPPT) functionality. The solar panel controller **1004** may also control electrically connecting/disconnecting groups of solar panels based on whether or not the panels are producing a harvestable amount of energy. For example, the solar panel controller **1004** may continuously monitor the electrical energy or power level present on each of the PV solar panel groups and if the energy level on any given PV solar panel group is above a specific level indicative of the solar panel group being sufficiently illuminated by sunlight to produce harvestable energy the controller may electrically connect the PV panels of the group to MPPT controller functionality. If the solar panel controller detected multiple panels as producing harvestable energy at the same time it may electrically

cally connect those multiple PV panels to the MPPT in a parallel arrangement, potentially dynamically increasing the harvestable power available to the MPPT controller. The PV panel with the lowest voltage rating will determine the maximum possible power that might be obtained in the parallel arrangement with mismatched PV panels under full sunlight. As any one of the multiple PV panels attached to the exterior of the meter becomes shaded as a result of the movement of the sun across the sky, the drop in output energy would be detected by the solar panel controller and that particular solar panel would be disconnected from the MPPT controller so as to keep only energy producing solar panels connected to the MPPT controller. Although not necessary, it may be desirable that all of the solar panels have the same voltage and current ratings. If it is not possible for all PV panels connected to the exterior of the meter to have the same voltage and current rating, the total additional power resulting from multiple PV panels being placed in parallel with each other by the solar panel controller will less than if all PV panels had identical voltage and current ratings.

[0070] The above has described connecting/disconnecting groups of solar panels in parallel to MPPT functionality. It is possible to include multiple instances of the MPPT functionality to control each group of solar panels independently at the panels optimum power output. The power output by the solar panels through the solar panel controller **1004** may be used to charge one or more rechargeable batteries **1006a**, **1006b** of the parking meter. The power circuitry **614** may include a battery controller **1008** that controls the charging of the batteries. For example the battery controller **1008** may control the voltage/current supplied to the batteries when charging. The battery controller **1008** may provide various functionality including for example balancing the individual cells of the batteries being charged.

[0071] The power output from the batteries, and possibly from the solar panel controller may be supplied to the power delivery functionality **1010** that supplies the required voltages/current to parking meter components.

[0072] The above has described a parking meter incorporating a touchscreen display. While the touchscreen may provide a desirable user interface for certain applications, it may not be desirable in all applications. For example, a city or purchaser of parking meters may not wish to incur the additional costs associated with a current large touchscreen display. Additionally or alternatively, the power consumption required by current display technologies may not meet certain requirements of a city or purchased or parking meters. Additionally or alternatively, the operating parameters, such as temperature, durability, lifetime, etc. of a current display technology may not meet the current requirements of a city or purchaser of parking meters. Although a touchscreen display may not be preferred by a city or purchaser of parking meters at the time of purchasing new parking meters, it may nonetheless become desirable or preferred to them subsequent to the purchase. Such retrofitting of existing parking meters to incorporate new features typically requires replacing a parking meter unit that is enclosed within the existing parking meter housing which is retained. For example for single space parking meters, the retrofit may comprise fitting a new removable parking meter mechanism within the existing parking meter housing. As a further example, for multi-space parking meters, new park-

ing meter components may be fitted to a door of the multi-space meter. While these retrofit applications may provide a helpful way to provide new parking meter functionality without having to replace all of the existing infrastructure, it is nonetheless desirable to provide a parking meter with a means for easily retrofitting the user interfaces, which may comprise for example replacing a display and keypad or buttons, with a touchscreen display.

[0073] FIG. 11 depicts a parking meter providing an easily retrofitted user interface. The parking meter **1100** is depicted as a multi-space style parking meter. The parking meter **1100** comprises a cabinet **1102** that includes a hinged or removable door or panel **1104**. The cabinet **1102** may also include a second door or panel **1106** which may be used for example to access a coin vault or other internal components. The door or panel **1104** may have a main door portion **1108** formed from a material such as stainless steel or other similar materials providing sufficient strength for protecting against vandalism. The door or panel **1104** portion **1108** may have a covering portion **1110** covered by a second material such as aluminum. The covering portion **1110** may cover a number of cutout sections within the main door portion **1108**. The covering **1110** may be formed from an easily formed and/or machined material that can provide a precise fit around the components placed in cutouts of the main door portion **1108**. For example, the main door portion **1108** may have a cutouts for receiving payment components such as a tap or contactless payment sensor **1112a**, a coin chute **1112b** and a card reader **1112c** (referred to collectively as payment devices **1112**). The cover **1110** may provide an aesthetically pleasing look to the parking meter door. The cover **1110** may be secured to the main door portion **1108** using one or more bolts or carriage bolts, one of which **1112** is labelled in FIG. 11. In addition to the cutouts for the payment devices **1112**, the main door portion **1108** and the cover **1110** may have a cutout that receives a correspondingly sized panel insert **1114**. The panel insert **1114** can be secured to the main door portion **1108** in various ways, one of which is further described with regard to FIGS. 13 and 14. The panel insert **1114** includes cutouts for user interface components including user interface components for input depicted as buttons **1116** and components for output depicted as display **1118**. The panel insert **1114** allows the user interface components to be easily changed to new or different user interface components or configurations by simply replacing the insert panel **1114** instead of the entire panel door **1104**.

[0074] FIGS. 12A-12C depict various panel inserts for retrofitting user interfaces of the parking meter of FIG. 11. As depicted, each of the panel inserts **1214a**, **1214b**, **1214c** has the same perimeter shape and size so that any one of the panel inserts **1214a**, **1214b**, **1214c** can be received within the panel cutout of the main panel **1108** and cover **1110**. Each of the panel inserts **1214a**, **1214b**, **1214c** may have one or more cutouts providing arrangements of different user interface components. For example, the panel insert **1214a** comprises cutouts for a display with a plurality of LED lights **1202a**, a physical alphanumeric keypad **1204a** and a physical keypad **1206**. Panel insert **1214b** may have cutouts for a display **1202b** and a touchscreen keyboard **1204b** and panel insert **1214c** may have a single cutout for a touchscreen display **1202c**. As will be appreciated, the parking meter with a panel cutout described above with reference to FIG. 11 may be easily upgraded or retrofitted with different user interface components such as the display, keyboard and

keypad of insert panel **1214a**, the display and touch screen keyboard of insert panel **1214b** or the touchscreen display **1214c**. Other arrangements of user interface components may be provided by different panel inserts.

[0075] FIGS. **13A** and **13B** depict a top view and front view of an insert plate for a parking meter with an easily retrofitted user interface. The insert panel may have a raised panel portion **1302** that is sized to be received within the cutout of the main panel **1108** and the cover **1110** of the parking meter door of FIG. **11**. The raised panel portion **1302** includes one or more cutouts **1304** which are arranged to locate the user interface components. The components may be secured to the back of the raised panel portion using bolts, studs, clips, or other features. In order to secure the panel insert within the corresponding cutout of the parking meter, the panel insert may have a flange **1306**. The flange may have one or more holes **1308** through which bolts, studs, etc. may be received to secure the insert panel. The flange may also include one or more relief cuts or cutouts **1310** for providing relief around features on the back of the main portion where the flange is seated. For example, the relief cutout **1310** may be a hole that allows the panel insert to be removed without having to first remove a carriage bolt and or nut used to secure the cover **1110** to the main portion **1108**.

[0076] FIG. **14** depicts assembly of the easily retrofitted user interface of the parking meter of FIG. **11**. As depicted, the cover **1110** may be secured to the main portion **1108** of the parking meter door by respective carriage bolts and nuts **1402** passing through the cover **1110** and the main portion **1108** and secured to the back of the main portion **1108**. As described above with regard to FIG. **13**, the flange of the insert panel **1114** may have relief cuts or cutouts around the nuts and bolts **1402** used to secure the cover **1110** to the main portion **1108**. The back side of the main portion **1108** of the door may include one or more posts **1404** that are used to secure the insert panel to the main portion **1108**. Although not depicted in FIG. **14**, the inside of the panel insert may have one or more features used to secure the user interface components to the panel insert.

[0077] Although certain components and steps have been described, it is contemplated that individually described components, as well as steps, may be combined together into fewer components or steps or the steps may be performed sequentially, non-sequentially or concurrently. Further, although described above as occurring in a particular order, one of ordinary skill in the art having regard to the current teachings will appreciate that the particular order of certain steps relative to other steps may be changed. Similarly, individual components or steps may be provided by a plurality of components or steps. One of ordinary skill in the art having regard to the current teachings will appreciate that the components and processes described herein may be provided by various combinations of software, firmware and/or hardware, other than the specific implementations described herein as illustrative examples.

[0078] Numerous additional variations on the methods and apparatus of the various embodiments described above will be apparent to those skilled in the art in view of the above description. Such variations are to be considered within the scope.

What is claimed is:

1. A parking meter comprising:
 - a meter housing;

metering components within the meter housing, the metering components comprising:

- a display;
 - a touch sensor overlaid on the display;
 - a low-power wake trigger; and
 - at least one controller configured to turn on the display when the low-power wake trigger provides a wake signal.
2. The parking meter of claim **1**, wherein the low-power wake trigger comprises a secondary touch sensor overlaid on the touch sensor.
 3. The parking meter of claim **2**, wherein the secondary touch sensor is capable of providing an indication that a touch occurred without providing coordinates of the touch.
 4. The parking meter of claim **3**, wherein the display, touch sensor and secondary touch sensor together form a touchscreen display assembly.
 5. The parking meter of claim **4**, wherein the at least one controller is configured to turn off the display of the touchscreen assembly after an inactivity period of time.
 6. The parking meter of claim **5**, wherein the at least one controller is configured to turn on the touch sensor when the display is turned on and turn off the touch sensor when the display is turned off.
 7. The parking meter of claim **3**, wherein the at least one controller is configured to turn off the display after an inactivity period of time.
 8. The parking meter of claim **7**, wherein the at least one controller is configured to turn on the touch sensor when the display is turned on and turn off the touch sensor when the display is turned off.
 9. The parking meter of claim **1**, wherein the at least one controller is configured to turn off the display after an inactivity period of time.
 10. The parking meter of claim **9**, wherein the at least one controller is configured to turn on the touch sensor when the display is turned on and turn off the touch sensor when the display is turned off.
 11. A parking meter comprising:
 - metering components comprising:
 - a display;
 - a touch sensor overlaid on the display;
 - a low-power wake trigger; and
 - at least one controller configured to turn on the display when the low-power wake trigger provides a wake signal;
 - an insert comprising one or more openings for receiving respective user interface components;
 - an external housing component enclosing the metering components, the external housing component comprising:
 - at least one opening for a payment device; and
 - at least one cutout for receiving the insert housing, wherein the insert is secured within the cutout of the external housing component.
 12. The parking meter of claim **11**, wherein the low-power wake trigger comprises a secondary touch sensor overlaid on the touch sensor.
 13. The parking meter of claim **12**, wherein the secondary touch sensor is capable of providing an indication that a touch occurred without providing coordinates of the touch.

14. The parking meter of claim 13, where the insert comprises a plurality of openings including a first opening for the display and a second opening for a keyboard or keypad.

15. The parking meter of claim 11, wherein the parking meter is a multi-space parking meter and the external housing component comprises a door panel of a cabinet of the multi-space parking meter.

16. The parking meter of claim 11, wherein the insert is secured within the cutout by bolts secured to an inside of the external housing.

17. The parking meter of claim 11, wherein the parking meter is a single space parking meter.

18. The parking meter of claim 11, where the insert comprises a plurality of openings including a first opening for the display and a second opening for a keyboard or keypad.

19. The parking meter of claim 11, wherein the at least one controller is configured to turn off the display after an inactivity period of time.

20. The parking meter of claim 19, wherein the at least one controller is configured to turn on the touch sensor when the display is turned on and turn off the touch sensor when the display is turned off.

* * * * *