



(51) International Patent Classification:
A61C 7/12 (2006.01)

(21) International Application Number:
PCT/US2018/035091

(22) International Filing Date:
30 May 2018 (30.05.2018)

(25) Filing Language: English

(26) Publication Language: English

(30) Priority Data:
62/512,922 31 May 2017 (31.05.2017) US
15/991,509 29 May 2018 (29.05.2018) US

(72) Inventors; and

(71) Applicants: DARLING, Steven [US/US]; 106 Bonito Drive, Ocean Ridge, FL 33435 (US). DARLING, Janis [US/US]; 106 Bonito Drive, Ocean Ridge, FL 33435 (US).

(74) Agent: DOWNEY, Robert, M.; Robert M. Downey, P.A., 6751 N. Federal Hwy., Suite 300, Boca Raton, FL 33487 (US).

(81) Designated States (unless otherwise indicated, for every kind of national protection available): AE, AG, AL, AM, AO, AT, AU, AZ, BA, BB, BG, BH, BN, BR, BW, BY, BZ, CA, CH, CL, CN, CO, CR, CU, CZ, DE, DJ, DK, DM, DO, DZ, EC, EE, EG, ES, FI, GB, GD, GE, GH, GM, GT, HN, HR, HU, ID, IL, IN, IR, IS, JO, JP, KE, KG, KH, KN, KP, KR, KW, KZ, LA, LC, LK, LR, LS, LU, LY, MA, MD, ME, MG, MK, MN, MW, MX, MY, MZ, NA, NG, NI, NO, NZ, OM, PA, PE, PG, PH, PL, PT, QA, RO, RS, RU, RW, SA, SC, SD, SE, SG, SK, SL, SM, ST, SV, SY, TH, TJ, TM, TN, TR, TT, TZ, UA, UG, US, UZ, VC, VN, ZA, ZM, ZW.

(84) Designated States (unless otherwise indicated, for every kind of regional protection available): ARIPO (BW, GH, GM, KE, LR, LS, MW, MZ, NA, RW, SD, SL, ST, SZ, TZ, UG, ZM, ZW), Eurasian (AM, AZ, BY, KG, KZ, RU, TJ,

(54) Title: COVER FOR BRACKET OF ORTHODONTIC APPLIANCE

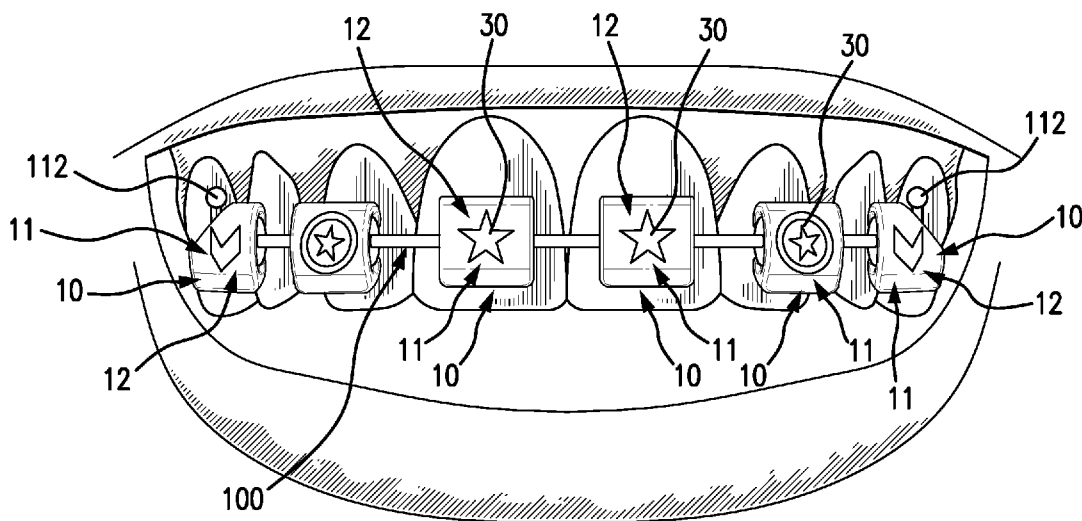

FIG. 1A

(57) Abstract: A cover device formed of a plastic or similar composition is structured for removable attachment over a bracket of an orthodontic appliance and includes a main plate with an outer front face, and top and bottom claws integrally formed with the main plate, curling behind the main plate, and each terminating at distal ends in spaced, opposing relation to each other behind the main plate. The main plate is bowed outwardly from top to bottom to allow the claws to flex away from each other and snap over the bracket upon application of inward pressure on the front face while the claws are pressed against the bracket, to thereby attach the cover to the bracket, with the bracket concealed from view behind the cover device. The front face may include an ornamental design. In another embodiment, the cover device includes a bottom tab for cooperating engagement with a removal tool.



TM), European (AL, AT, BE, BG, CH, CY, CZ, DE, DK, EE, ES, FI, FR, GB, GR, HR, HU, IE, IS, IT, LT, LU, LV, MC, MK, MT, NL, NO, PL, PT, RO, RS, SE, SI, SK, SM, TR), OAPI (BF, BJ, CF, CG, CI, CM, GA, GN, GQ, GW, KM, ML, MR, NE, SN, TD, TG).

Published:

— *with international search report (Art. 21(3))*

COVER FOR BRACKET OF ORTHODONTIC APPLIANCE

BACKGROUND OF THE INVENTION5 Field of the Invention

This invention relates to accessory devices for orthodontic appliances and, more particularly, to a cover device for attachment to individual brackets on a patients teeth to provide an enhanced appearance of the orthodontic appliance without producing any tractive force on the arch wire. The invention may further include a tool that can be used
10 by the patient to easily remove the cover device from the bracket.

Discussion of the Related Art

Orthodontic appliances commonly referred to as “dental braces” typically include brackets that are cemented to the outer facing surface of the patient’s teeth and
15 an arch wire that is held by the brackets and tightened to provide desired forces for aligning and straightening the patient’s teeth. Traditional dental braces use elastic ties (o-ring ligators) that are stretched over and fitted onto the brackets for exerting a continually acting tractive force that urges the arch wire inwardly against the brackets and teeth.

20 While dental braces are highly effective and still one of the most commonly used orthodontic appliance for straightening and aligning teeth, they are generally unattractive. In particular, many orthodontic patients find the brackets on the exposed face of the teeth to be unappealing and they may even feel embarrassed and reluctant to smile. In an effort to enhance the overall appearance of dental braces, various

elastomeric ligation devices have been proposed in the past. Some of these elastomeric ligators include a membrane or outer skin that covers and conceals the bracket from view when the ligator is attached over the bracket. Examples of these types of elastomeric ligators are found in U.S. Patent No. 3,758,947 to Kissling and U.S. Patent 5 No. 7,204,691 to Darling et al. These elastomeric ligator devices and other ligation devices that have been proposed in the past exert pressure on the arch wire in order to secure the arch wire to the bracket. The law in most states requires that the operation of securing or unsecuring by attaching or removing a fastening device must be done under a minimum of indirect supervision by a licensed dentist, whereby the licensed dentist 10 must examine the patient, diagnose a condition to be treated, authorize the procedure to be performed and be on the premises while the procedure is being performed by a dental assistant. Accordingly, while the various elastomeric ligation devices proposed in the past have been effective to conceal the generally unsightly bracket of orthodontic appliances, they are not suited to be attached or removed by the patient. Thus, the 15 patient is not able to remove these elastomeric ligation devices each night or when desired, such as when brushing the teeth or simply to remove or interchange different cover devices over the brackets.

Accordingly, there still remains a need in the field of orthodontics, for a cover device that can be easily attached and removed over a brace of a dental appliance by the 20 patient, as desired, without the need of supervision by a licensed dentist and/or the involvement of a dental assistant.

Summary of the Invention

The present invention is directed to a cover device for attachment over a bracket of an orthodontic appliance and a tool for removing the cover device from the bracket. The cover device is formed of a plastic composition or similar material and is specifically sized, structured and configured to be attached over a single bracket, while engaging the undercut of the bracket in order to hold the cover device thereon. The cover device includes a main plate with an outer front face, and top and bottom claws that are integrally formed with the main plate. The top and bottom claws curl behind the main plate and terminate at distal ends in spaced, opposing relation to one another, and also spaced from the rear side of the main plate. The main plate is bowed outwardly from top to bottom so that the front face is convex and the rear side is concave. The bowed shape of the main plate, when in a relaxed state, allows the claws to flex away from one another and snap over the bracket upon application of inward pressure on the front face with the claws pressed against the bracket. This allows for snap-fit attachment of the cover device over the bracket with the distal ends of the top and bottom claws positioned in frictional engagement with an undercut on the back side of the bracket to discourage movement of the cover device relative to the bracket once attached thereto. When the cover device is attached to the bracket, the bracket is concealed from normal view. Orthodontic wax and/or silicon may be placed within the rear side of the cover device to promote attachment of the cover device on the bracket.

In another embodiment, the cover device includes a tab extending downwardly from a bottom of the cover device to facilitate patient removal with use of various embodiments of a removal tool. The tool includes a lifting member that is positioned

under the tab of the cover device to exert an outward prying force on the back of the tab, thereby lifting the cover device off of the bracket.

The front face of the cover device may include any of various designs, shapes, symbols, team logos, etc. for enhancing the ornamental appearance of the cover device, while also allowing for the individualized expression of each patient. The cover device may also be provided in various colors to accommodate the desires of the patient. For instance, patients may choose colors according to holidays such as, for example, black and orange for Halloween or red white and blue for Independence Day. Patients may also choose colors based on school colors or the colors of the patients favorite sports team. Moreover, the front face of the cover device may serve as a base for any number of 3-dimensional designs.

Objects and Advantages of the Invention

Considering the forgoing, it is a primary object of the present invention to provide a cover device that is structured and disposed to be attached over a bracket of a dental appliance to conceal the bracket from view and enhance the appearance of the dental appliance.

It is a further object of the present invention to provide a cover device for removable attachment over the bracket of a dental appliance, and wherein the cover device does not attempt to secure or unsecure the arch wire of the orthodontic appliance from the bracket.

It is still a further object of the present invention to provide a cover device for removable attachment over a bracket of an orthodontic appliance to conceal the bracket from view, and wherein the cover device can be attached to the bracket and removed

from the bracket by the patient without the need of a dental assistant and/or supervision of a licensed dentist.

It is yet a further object of the present invention to provide a cover device that is specifically designed, structured and disposed for removable attachment over the bracket of a dental appliance by the patient, and wherein the patient can easily remove
5 the cover device from the bracket by simply sliding the cover device laterally to either side of the bracket, with the use of slight force of the fingers, until the top and bottom claws of the cover device clear the prongs of the bracket.

It is still a further object of the present invention to provide a cover device that is
10 specifically designed, structured and disposed for removable attachment over the bracket of a dental appliance by the patient, and wherein the patient can easily remove the cover device from the bracket with the use of a specially designed tool when desired, and thereby providing for improved oral hygiene whereby the patient can remove multiple cover devices from brackets on multiple teeth in order to clean underneath the
15 brackets.

It is still a further object of the present invention to provide a cover device for removable attachment over a bracket of an orthodontic appliance, and wherein the cover device helps to minimize abrasion of the inside tissue of the lips and cheeks within the patients mouth.

It is still a further object of the present invention to provide a cover device for
20 removable attachment over a bracket of an orthodontic appliance, and wherein the cover device may include various designs, shapes, symbols, team logos, etc. on an exposed front face that is clearly visible when the patient smiles.

It is still a further object of the present invention to provide a cover device for removable attachment over a bracket of an orthodontic appliance, and wherein the cover device may be provided in a variety of colors to accommodate the needs, desires and personal taste of each patient.

5 These and other objects and advantages of the present invention are more readily apparent with reference to the accompanying drawings.

Brief Description of the Drawings

For a fuller understanding of the nature of the present invention, reference
10 should be made to the following detailed description taken in conjunction with the accompanying drawings in which:

Figure 1A is a front elevational view showing the cover devices of the present invention fitted over brackets of an orthodontic appliance on six front teeth of a patient including the four incisors and the two canines, in accordance with one embodiment of
15 the invention;

Figure 1B is a front elevational view showing the cover devices of the present invention fitted over brackets of an orthodontic appliance on six front teeth of a patient including the four incisors and the two canines, in accordance with another embodiment of the invention;

20 Figure 2 is an isolated front elevational view showing two incisor teeth of the patient with the orthodontic appliance, including an arch wire and bracket, and further illustrating the cover device of the present invention attached over one of the brackets of the orthodontic appliance;

Figures 3A-3B illustrate a sequence of snap-fit attachment of the cover device of the present invention over a bracket of the orthodontic appliance;

Figure 4 is an isolated front elevational view of a single tooth illustrating lateral sliding removal of the cover device of the present invention from the bracket of the
5 orthodontic appliance;

Figure 5 is a rear, side perspective view of the cover device of the present invention, according to one embodiment;

Figure 6 is a front elevational view of the cover device of Figure 5 showing a front face of the cover device with an ornamental design thereon;

10 Figure 7 is a rear elevational view of the cover device of Figure 5;

Figure 8 is a left end elevational view of the cover device of Figure 5;

Figure 9 is a rear perspective view of a tool for use in removing the cover device of the present invention in accordance with one embodiment thereof;

Figure 10 is a front, side perspective view of the tool of Figure 9;

15 Figure 11 is a side elevational view, shown in partial cross section, illustrating movement of the tool of Figures 9-10 into position for removing the cover device from the bracket of the orthodontic appliance, in accordance with a second embodiment of the cover device of the present invention;

20 Figure 12 is a side elevational view, shown in partial cross section, showing the tool of Figures 9-10 in position for removing the cover device from the bracket of the orthodontic appliance;

Figure 13 is a side elevational view, in partial cross section, illustrating operation of the tool to engage a tab extending from the bottom of the cover device in accordance

with the second embodiment of the cover device of the present invention, for prying the cover device off of the bracket of the orthodontic appliance;

Figure 14 is a side rear perspective view of the cover device of the present invention in accordance with the second embodiment thereof;

5 Figure 15 is a front elevational view showing a front exposed face of the cover device of Figure 14, with an ornamental design thereon;

Figure 16 is a rear elevational view of the cover device of Figure 14;

Figure 17 is a side elevational view of the cover device of Figure 14;

10 Figure 18 is a front perspective view of a further embodiment of the cover device of the present invention that is specially designed for attachment to a bracket of the orthodontic appliance that contains a fixed hook;

15 Figure 19 is a front perspective view of the third embodiment of the cover device of the present invention that is specially designed for attachment to a bracket of the orthodontic appliance on the opposite tooth of the patient where the bracket contains a fixed hook;

Figure 20 is a side elevational view of a second embodiment of a tool for use in removing the second embodiment of the cover device of the present invention from the bracket of the orthodontic appliance; and

20 Figure 21 is a side elevational view, shown in partial cross section, illustrating positioning of the tool of Figure 20 in relation to the arch wire, bracket and cover device for removing the cover device from the bracket of the orthodontic appliance.

Like reference numerals refer to like parts throughout the several views of the drawings.

Detailed Description of the Preferred Embodiments

Referring initially to Figure 1A, the cover device of the present invention is shown installed on brackets fixed to a patient's upper incisor teeth and canine teeth, according to a first embodiment of the invention. Figure 1B illustrates a second
5 embodiment of the cover devices installed on brackets fixed to a patient's upper incisor teeth and canine teeth. The cover device of the present invention is generally indicated as 10 throughout the several views of the drawings and is specifically structured for snap-fit attachment and removal from brackets 102 of an orthodontic appliance 100 having an arch wire 104 extending through the brackets 102, as seen in Figures 1 and 2.
10 Each bracket 102 is bonded to a single tooth T of the patient.

Referring to Figures 2-8, the first embodiment of the cover device 10 of the present invention is shown and includes a main plate 11 having an outer front face 12, a top end 13, a bottom end 14, opposite side edges 15, 16 and a rear side 18. A top claw 20 is integrally formed with the main plate 11 and extends from the top end 13 of the
15 main plate and curls back and downwardly behind the main plate, terminating at a distal end 24, as best seen in Figures 3A-3B and Figure 8. A bottom claw 22 is integrally formed with the main plate 11 and extends from the bottom end 14 of the main plate 11 and curls back and upwardly behind the main plate 11, terminating at a distal end 26, so that the distal ends 24, 26 of the upper and lower claws are spaced in opposing relation
20 to one another and spaced from the rear side 18 of the main plate 11, as seen in Figures 3A-3B and Figure 8.

In a preferred embodiment, the cover device 10 is formed of a plastic composition or other similar composition that is generally rigid, but has memory. Thus, the molded material composition can be flexed to deform from a relaxed state upon

application of an external force, but seeks to return back to the original relaxed state upon removal of the external force. It should be noted that when fitted to a bracket 102, the cover device 10 does not fully return to the relaxed state so the cover device 10 maintains frictional engagement with the bracket 102 under constant grasping tension, thereby avoiding undesirable movement of the cover device 10 relative to the bracket 102.

In a preferred embodiment, the main plate is bowed from the top end 13 to the bottom end 14 so that the outer face 12 is generally convex and the rear side 18 is generally concave. The bowed structure of the main plate 11 allows the main plate 10 to be deformed inwardly towards the distal ends 24, 26 of the claws 20, 22 upon application of an external force when the top and bottom claws 20, 22 are pressed against the bracket 102 of the orthodontic appliance 100. More specifically, referring to Figures 3A and 3B, a sequence of attachment of the cover device 10 is shown wherein the cover device 10 is positioned in front of the bracket and a force is applied to the outer front face 12 of the main plate 11 causing the main plate to flex and deform inwardly. This causes the top and bottom claws 20, 22 to flex away from one another so that the distal ends 24, 26 of the top and bottom claws move further apart from one another. This allows the top claw 20 and the bottom claw 22 to move over and around the bracket 102, as seen in Figure 3A. Further inward movement of the cover device 10 relative to the bracket, eventually allows the distal ends 24, 26 of the top and bottom claws to close towards one another within an undercut on the back side of the bracket 102 in a snap-fit action. Figure 3B shows the cover device 10 attached on the bracket 102. When the cover device 10 is attached to the bracket 102, the top claw 20 and the bottom claw 22 have not quite returned to the fully relaxed state, so that the top and

bottom claws maintain pressure on the bracket 102, to create frictional engagement between the cover device 10 and the bracket 102. This helps to maintain the cover device 10 on the bracket 102, wherein one or more cover devices 10 on brackets 102 of the dental appliance remain securely attached without undesirable movement or easy
5 dislodgement.

As seen in Figures 5 and 8, the opposite sides of the cover device 10 are open between the side edges 15, 16 of the main plate 12 and the top and bottom claws 20, 22. The open opposite sides of the cover device 10 are sized and configured to allow passage of the bracket 102 outwardly therethrough upon application of an external
10 lateral force to the cover device 10 that is sufficient to overcome the force of frictional engagement of the top and bottom claws 20, 22 with the bracket 102 and slide the cover device 10 sideways off of the bracket 102, as illustrated in Figure 4. Once the cover device 10 completely clears the bracket 102, as seen in Figure 4, the cover device 10 can be simply pulled outwardly away from the arch wire 104 of the dental appliance and
15 removed from the patient's mouth. Because the distance between brackets 102 on adjacent teeth T is greater than the width of the cover device 10, there is ample space between brackets to allow removal of the cover device 10 off of the orthodontic appliance 100, once the cover device 10 has been slid laterally off of the bracket and positioned between brackets on adjacent teeth.

20 As seen in Figures 1, 4 and 6, the front face 12 of the cover device 10 may be provided with an ornamental design, symbol, shape, team logo, or other indicia, 30 as desired by the user/patient.

A further embodiment of the cover device 10 is shown in Figures 11-19. In particular, a further embodiment of the cover device 10 includes a tab 50 extending

downwardly from the bottom end 14 of the main plate 11. The downwardly depending tab 50 is specifically structured and disposed for cooperating engagement with a tool for removing the cover device 10 from the bracket 102. Figures 9-13 illustrate one embodiment of a removal tool that engages the downwardly depending tab 50 on the cover device 10 for applying a prying force that separates the cover device 10 from the bracket 102. Specifically, the first embodiment of the removal tool is shown in Figures 9-13 and is generally indicated as 40. The tool 40 includes a handle portion 42 formed by two spaced apart, generally L-shaped members 43 and 44. A top end of L-shaped member 43 includes upwardly extending and spaced apart parallel arms 45 and 46 that are joined together by an arch member 49 to discourage separation or relative movement of the parallel arms 45, 46. A top end of the other L-shaped member 44 is provided with an upwardly extending lifting member 48.

Referring to Figures 11-13, a sequence of operational use of the tool 40 to remove the cover device 10 from the bracket 102 is illustrated. Specifically, to remove the cover device 10, the spaced apart parallel arms 45, 46 are positioned below and slightly in front of the downwardly depending tab 50 of the cover device and the tool 40 is then moved upwardly so that the top ends of the parallel arms 45, 46 are positioned in front of the arch wire, on opposite sides of the cover device 10. With the upper ends of the parallel arms 45, 46 engaged against the outer side of the arch wire, on opposite sides of the bracket 102, the tool 40 is moved upwardly so that the tapered end of the lifting member 48 is positioned under the tab 50 of the cover device 10. Stop elements 47 on the parallel arms 45, 46 engage the underside of the arch wire 104 to prevent over insertion of the lifting member 48, so that only the tab 50 is engaged by the lifting member 48 and not the undercut of the bracket 102 or the bottom claw 22 of the cover

device. With the fingers engaged with the outer side of L-shaped member 43 and the thumb engaged with a thumb plate on L-shaped number 44, a squeezing force is applied, causing the lifting member 48 to move against the back side of the tab 50 and outwardly away from the bracket 102, causing the bottom claw 22 to be pried off of the bracket 5 102, as seen in Figure 13. This effectively separates the cover device 10 from the bracket 102 so that it can be easily removed from the patient's mouth. It should be noted that this operation of use of the tool 40 can easily be performed by the patient without any assistance.

Referring to Figures 14 and 17, the second embodiment of the cover device 10 10 includes at least one stop member centrally positioned on the rear side for discouraging lateral movement of the cover device 10 relative to the bracket 102. As seen in Figure 17, a centrally positioned rib 54 extends from the rear side 18 of the main plate 12 to an inner side of both the top claw 20 and the bottom claw 22 to provide stop members 54. These two centrally positioned stop members 54 (i.e., upper and lower) are positioned 15 between left and right prong sets of the bracket 102 (see Figure 2) so that lateral movement of the cover device 10 relative to the bracket 102 will cause the stop members 54 to engage the prong sets of the bracket 102. This helps to prevent unwanted lateral movement and possible separation of the cover device 10 from the bracket 102. It should be noted, however, that with sufficient lateral force, the stop members 54 may 20 ride over the prong sets of the bracket 102 and thereby allow for separation and removal of the cover device 10 from the bracket 102.

As seen in Figures 1, 18 and 19, the cover device 10 is modified to accommodate a hook 112 on the dental appliance 100 that is normally positioned at the canine teeth. Specifically, to accommodate sufficient room for the hook 112 of the orthodontic

appliance, a portion of the top corner of the main plate 11 is removed, providing for an angled edge 60 extending from the main plate to the top claw 20 behind the main plate. As see in Figures 1, 18 and 19, one of the cover devices is made for the left canine tooth and the other cover device is made for the right canine tooth so that the two cover
5 devices, as seen in Figures 18 and 19, are essentially mirror images of one another.

A second embodiment of the removal tool is shown in Figures 20 and 21 and is generally indicated as 40a. The removal tool 40a has no moving parts and includes a lever 42a that extends to a working head that engages the arch wire 104 and the tab 50 of the cover device 10. Specifically, the stop member 47a is positioned against the
10 underside of the arch wire 104 to properly position the lifting member 48a behind the tab 50 of the cover device. In this position, as shown in Figure 21, the lever 42a of the tool is rotated upwardly, as indicated by the arrow in Figure 21, to effectively apply a prying force to the tab 50 that removes the bottom claw 22 from the bracket 102, effectively allowing separation and removal of the cover device 10 from the patient's
15 mouth. Again, the tool 40a is easily used by the patient, without assistance, to remove the cover device 10 from the bracket 102 of the orthodontic appliance 100.

Referring to Figure 22, a further embodiment of the invention contemplates a 3-dimensional design 70 on the outer face 12 of the base plate 11 of the cover device to provide for an enhanced ornamental appearance. In this particular example, the 3-
20 dimensional design 70 is shown as a fish, with a series of the cover devices attached to adjacent brackets on the patient's upper incisor teeth and canines presenting the appearance of fish swimming in a line, one behind the other. It should be noted that virtually any 3-dimensional shape is contemplated within the spirit and scope of the invention.

While the present invention has been shown and described in accordance with several preferred and practical embodiments, it is recognized that departures from the instant disclosure are fully contemplated within the spirit and scope of the following claims as interpreted under the Doctrine of Equivalents.

What is claimed is:

1. A cover device for attachment to a bracket that is fixed to a patient's tooth in an orthodontic appliance, said cover device comprising:

5 a main plate having an outer front face, a top end, a bottom end, opposite side edges and a rear side;

a top claw integrally formed with the main plate and extending from the top end of the main plate and curling behind the main plate, and a bottom claw integrally formed with the main plate and extending from the bottom end of the main plate and curling behind the main plate, and the top and bottom claws both
10 terminating at distal ends that are positioned in spaced, opposing relation to one another and spaced from the rear side of the main plate; and

the main plate being bowed outwardly from the top end to the bottom end when in a relaxed state, and the main plate being adapted to deform inwardly upon application of an external inward force to the front face with the top and
15 bottom claws engaged against a front side of the bracket to cause the top and bottom claws to flex away from one another and snap over the bracket and into frictional engagement with the bracket, to thereby attach the cover device to the bracket.

20 2. The cover device as recited in Claim 1 wherein the cover device is open at opposite sides between the opposite side edges and the top and bottom claws.

3. The cover device as recited in Claim 2 wherein the open opposite sides of the cover device are sized and configured to allow passage of the bracket outwardly

therethrough upon application of an external lateral force to the cover device that is sufficient to overcome a force of frictional engagement of the top and bottom claws with the bracket, to thereby slide the cover device sideways and off of the bracket.

5 4. The cover device as recited in Claim 1 wherein the cover device includes at least one stop member centrally positioned on the rear side for discouraging lateral movement of the cover device relative to the bracket.

10 5. The cover device as recited in Claim 1 wherein the cover device includes a tab extending downwardly from the bottom end of the main plate for cooperating engagement with a tool for removing the cover device from the bracket.

15 6. The cover device as recited in Claim 5 wherein the tool includes a lifting member that is structured and disposed for exerting an outward prying force to a back side of the tab for removing the cover device from the bracket.

20 7. The cover device as recited in Claim 6 wherein the cover device includes at least one stop member centrally positioned on the rear side for discouraging lateral movement of the cover device relative to the bracket.

 8. The cover device as recited in Claim 1 wherein the main plate and the top claw are structured and configured to provide clearance for a hook on the orthodontic appliance.

9. The cover device as recited in Claim 1 wherein the front face of the main plate includes a design thereon.

10. The cover device as recited in Claim 1 wherein the front face of the main
5 plate includes a 3-dimensional design thereon.

11. A cover device for attachment to a bracket that is fixed to a patient's tooth in an orthodontic appliance, said cover device comprising:

10 a main plate having an outer front face, a top end, a bottom end, opposite side edges and a rear side;

a top claw integrally formed with the main plate and extending from the top end of the main plate and curling behind the main plate, and a bottom claw integrally formed with the main plate and extending from the bottom end of the main plate and curling behind the main plate, and the top and bottom claws both
15 terminating at distal ends that are positioned in spaced, opposing relation to one another and spaced from the rear side of the main plate; and

the top and bottom claws being structured and disposed for snap-fit attachment over the bracket and into frictional engagement with the bracket to thereby attach the cover device to the bracket.

20

12. The cover device as recited in Claim 11 wherein the cover device is open at opposite sides between the opposite side edges and the top and bottom claws.

13. The cover device as recited in Claim 12 wherein the open opposite sides of the cover device are sized and configured to allow passage of the bracket outwardly therethrough upon application of an external lateral force to the cover device that is sufficient to overcome a force of frictional engagement of the top and bottom claws with the bracket, to thereby slide the cover device sideways and off of the bracket.

5

14. The cover device as recited in Claim 11 wherein the cover device includes at least one stop member centrally positioned on the rear side for discouraging lateral movement of the cover device relative to the bracket.

10

15. The cover device as recited in Claim 11 wherein the cover device includes a tab extending downwardly from the bottom end of the main plate for cooperating engagement with a tool for removing the cover device from the bracket.

15

16. The cover device as recited in Claim 15 wherein the tool includes a lifting member that is structured and disposed for exerting an outward prying force to a back side of the tab for removing the cover device from the bracket.

17. The cover device as recited in Claim 16 wherein the cover device includes at least one stop member centrally positioned on the rear side for discouraging lateral movement of the cover device relative to the bracket.

20

18. The cover device as recited in Claim 11 wherein the main plate and the top claw are structured and configured to provide clearance for a hook on the orthodontic appliance.

5 19. The cover device as recited in Claim 11 wherein the front face of the main plate includes a design thereon.

20. The cover device as recited in Claim 11 wherein the front face of the main plate includes a 3-dimensional design thereon.

10

15

20

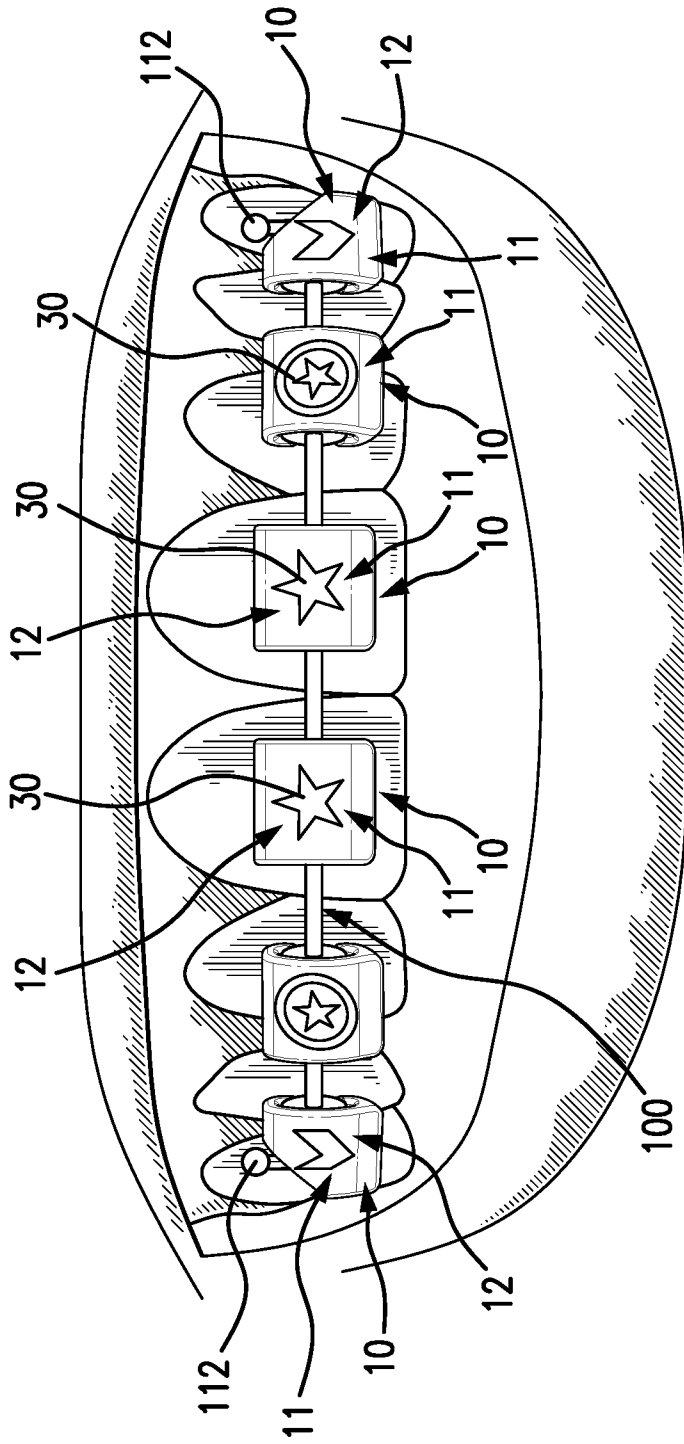

FIG. 1A

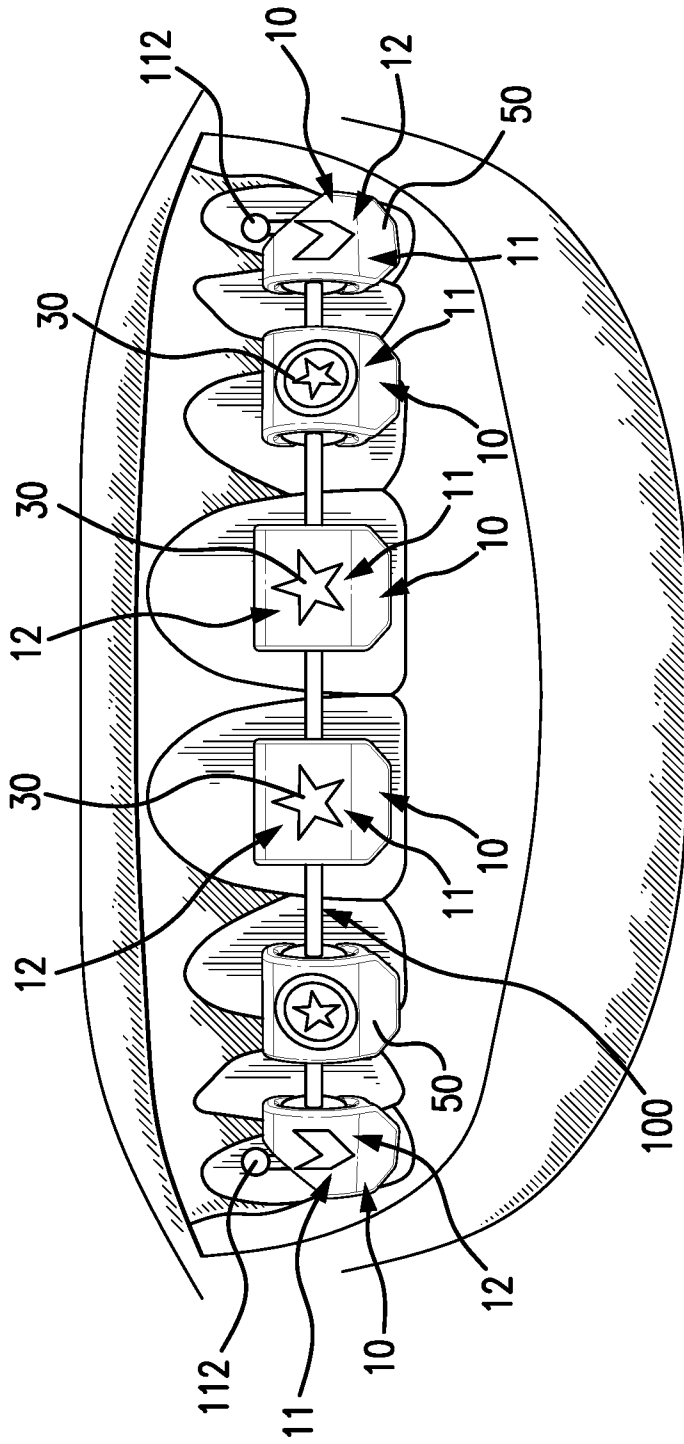

FIG. 1B

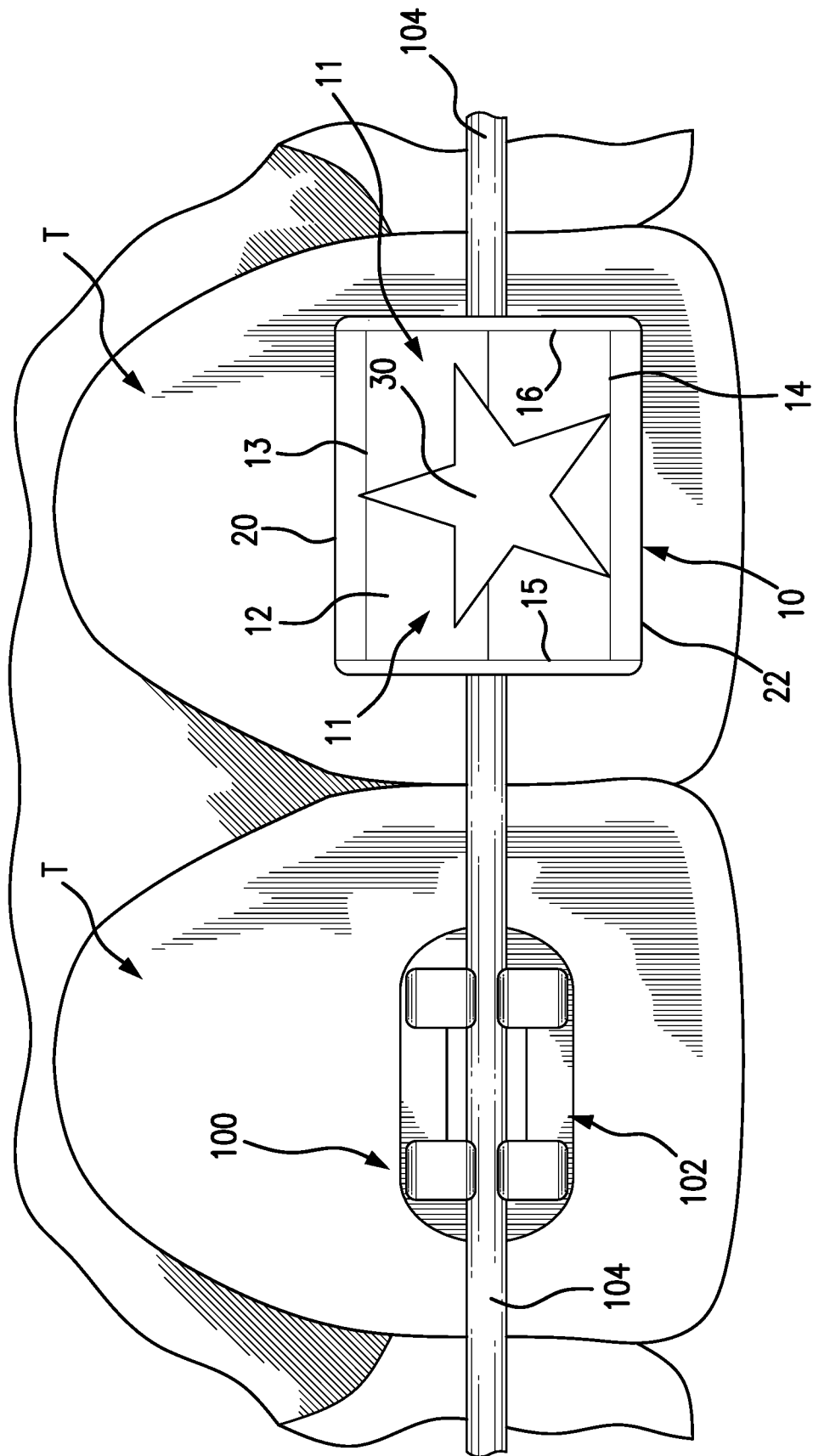

FIG. 2

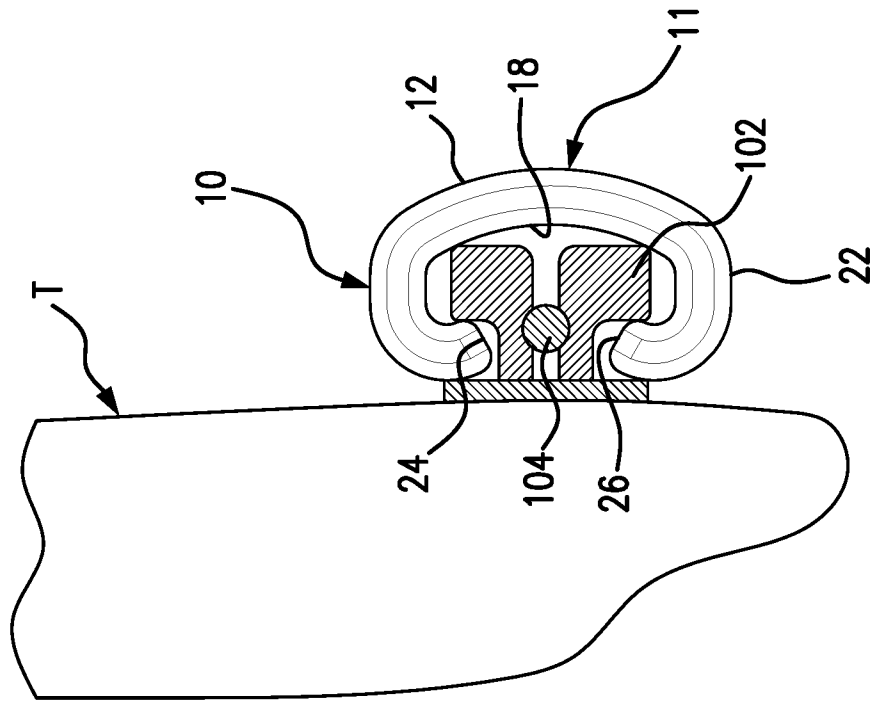

FIG. 3B

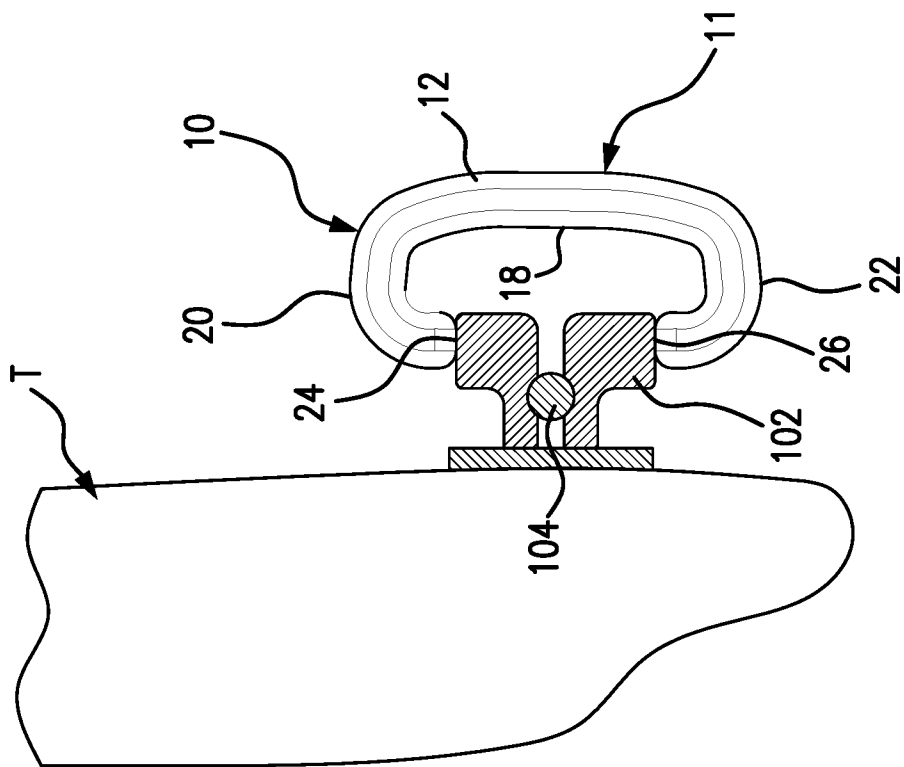

FIG. 3A

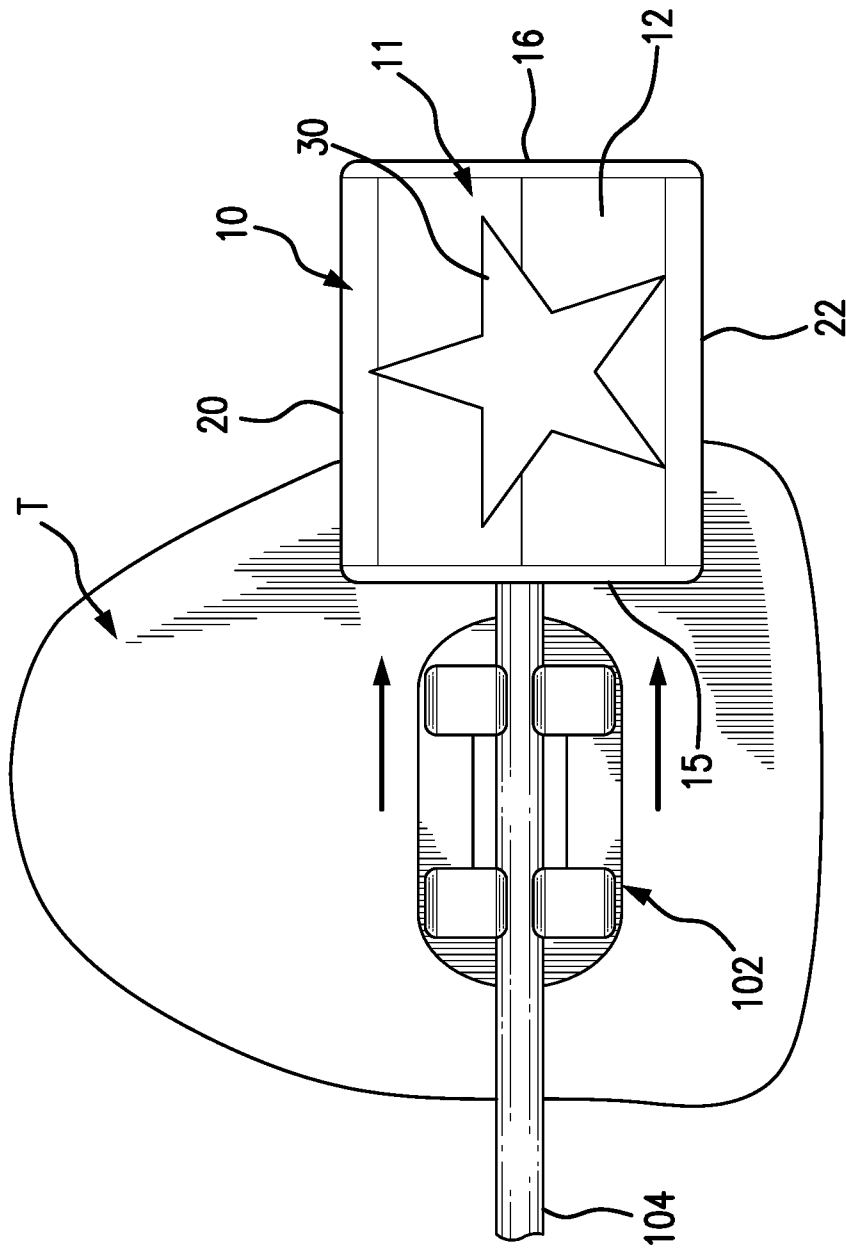

FIG. 4

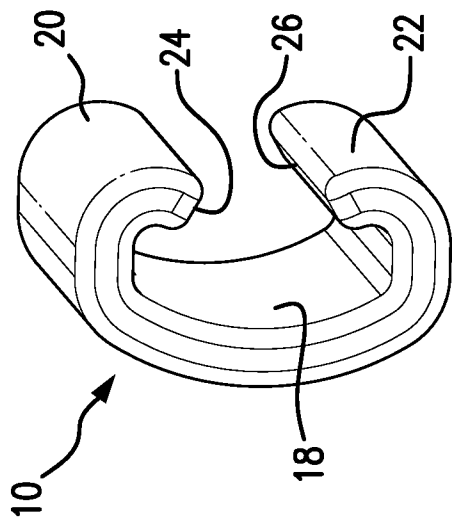
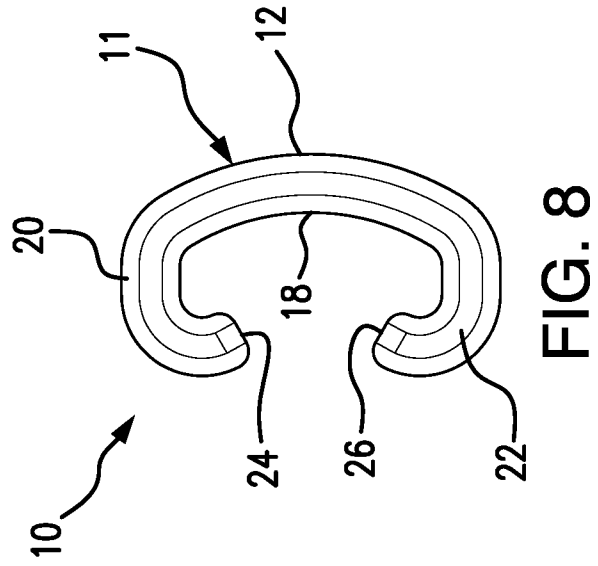
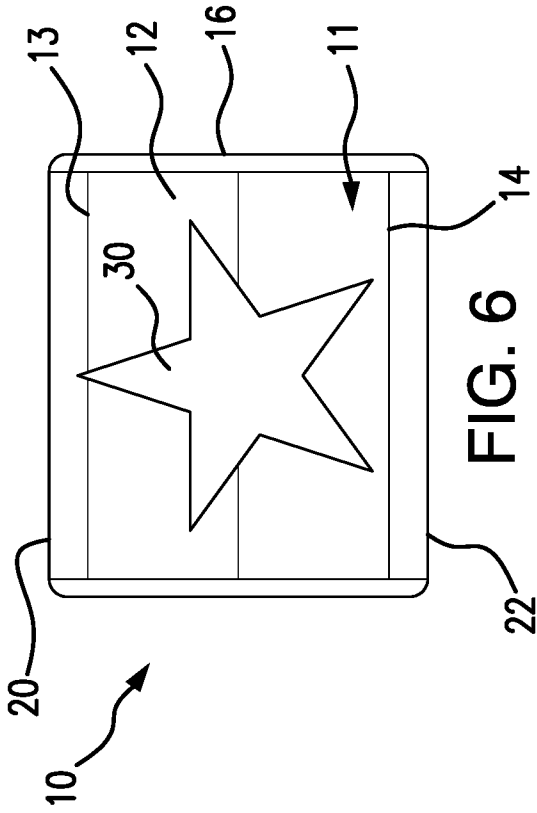

FIG. 5

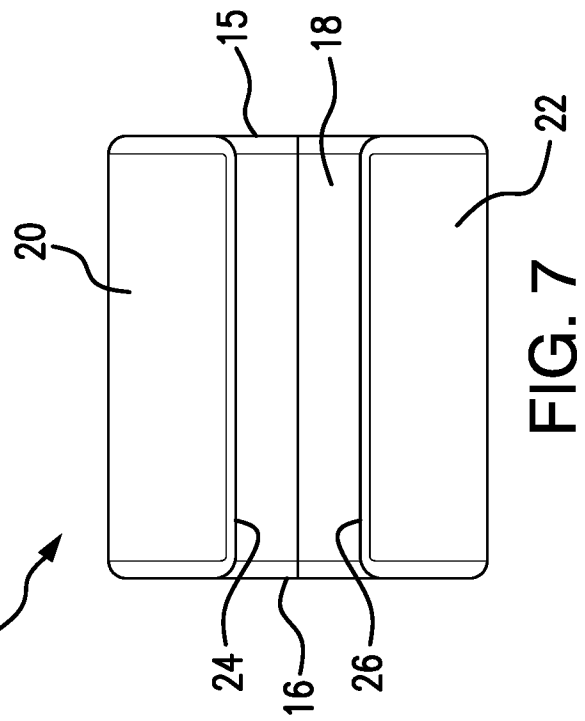
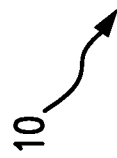

FIG. 7

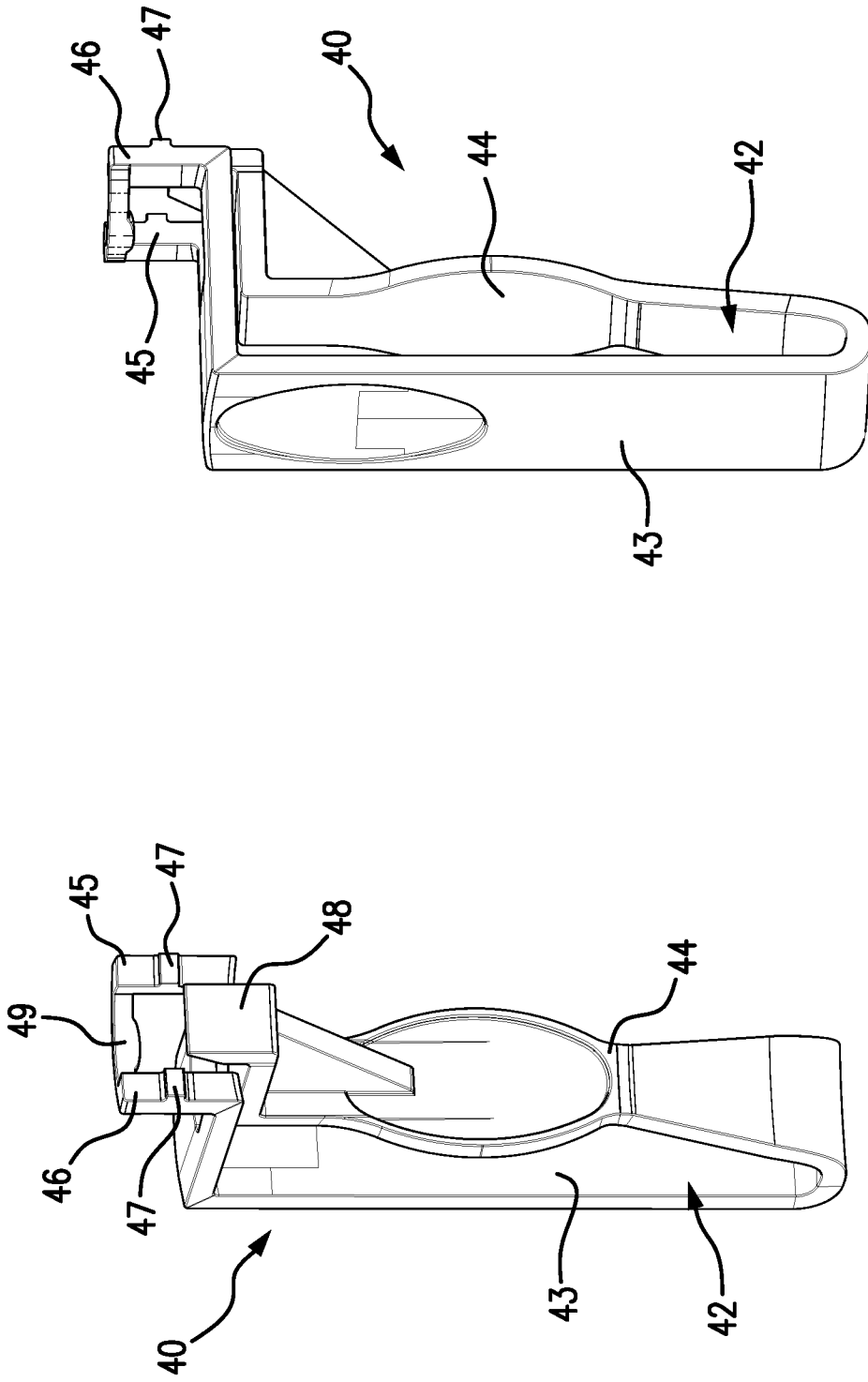

FIG. 10

FIG. 9

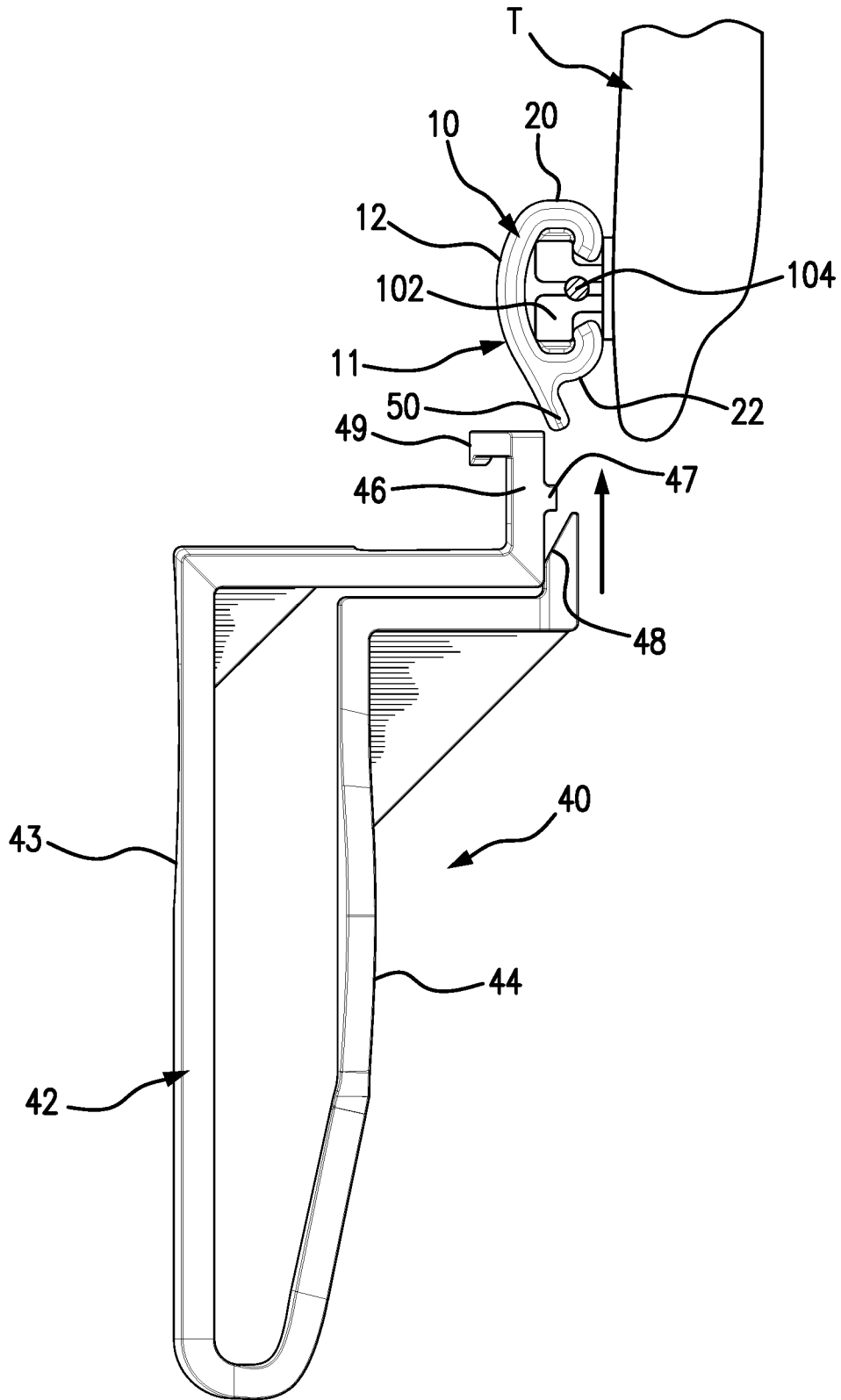

FIG. 11

9/13

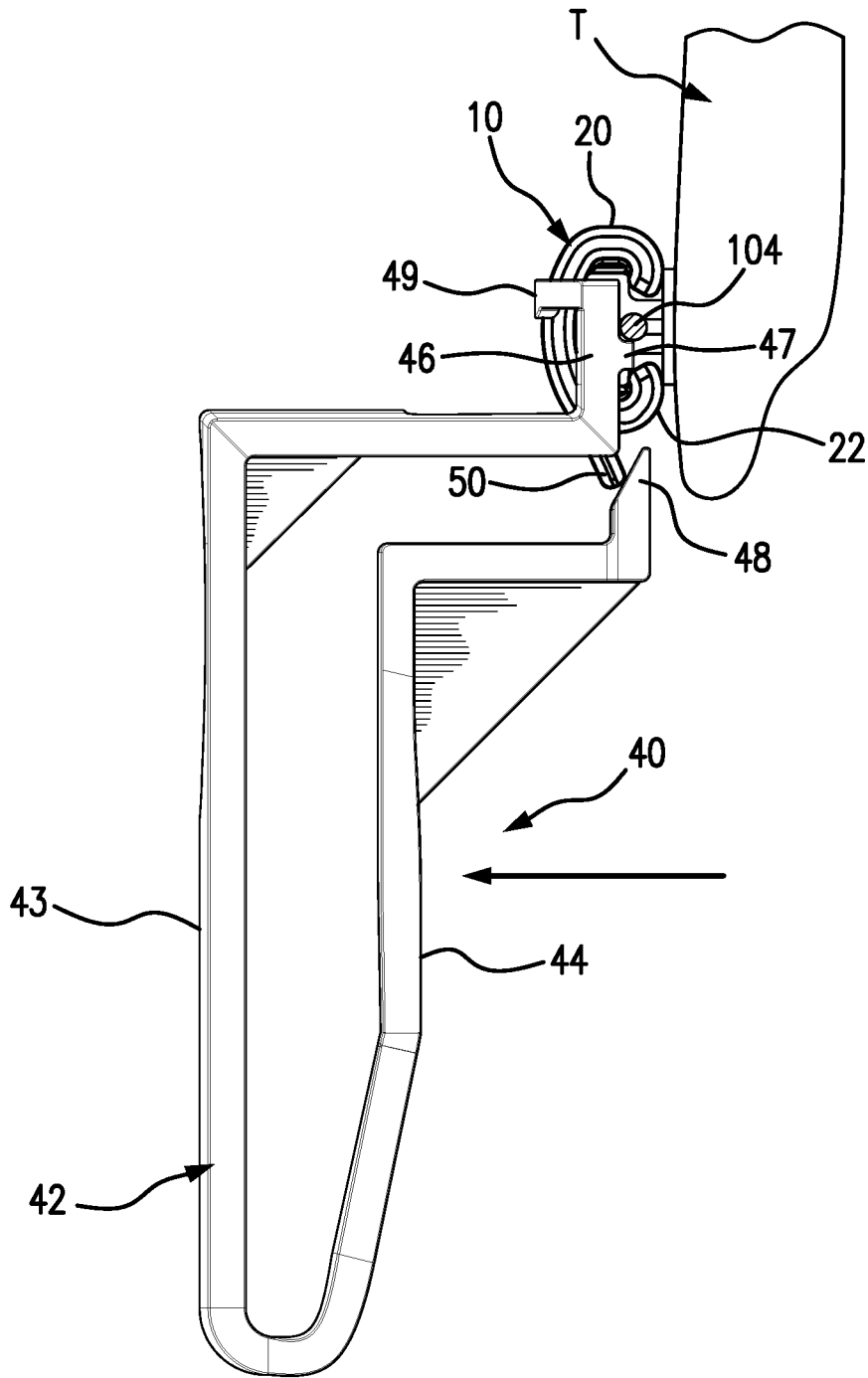

FIG. 12

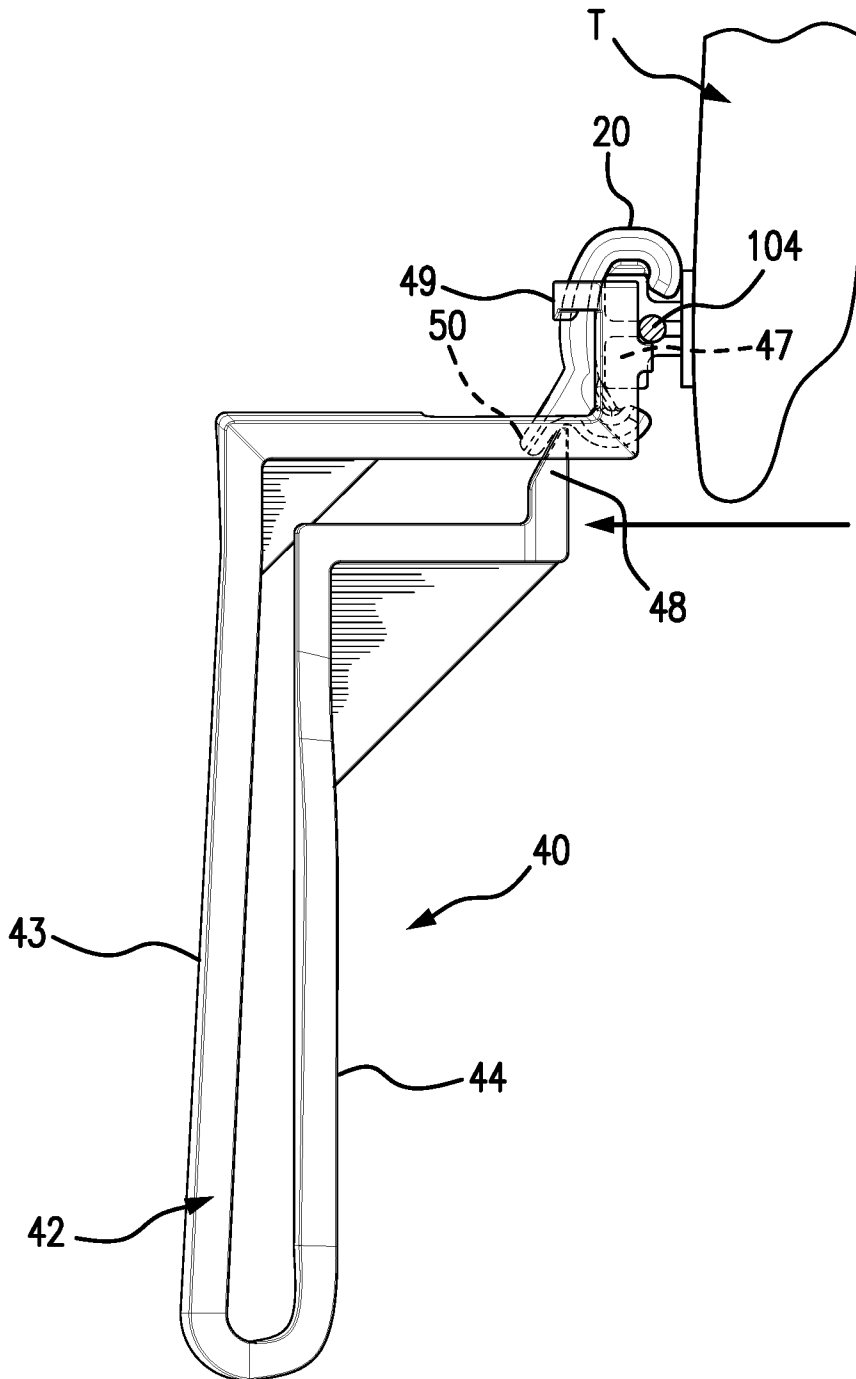

FIG. 13

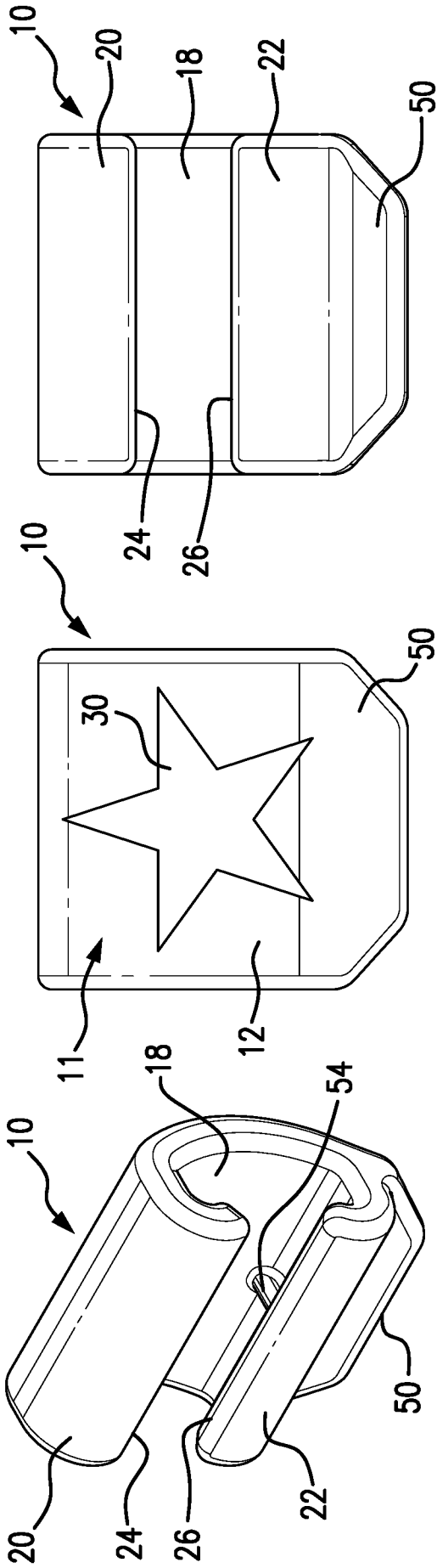

FIG. 16

FIG. 15

FIG. 14

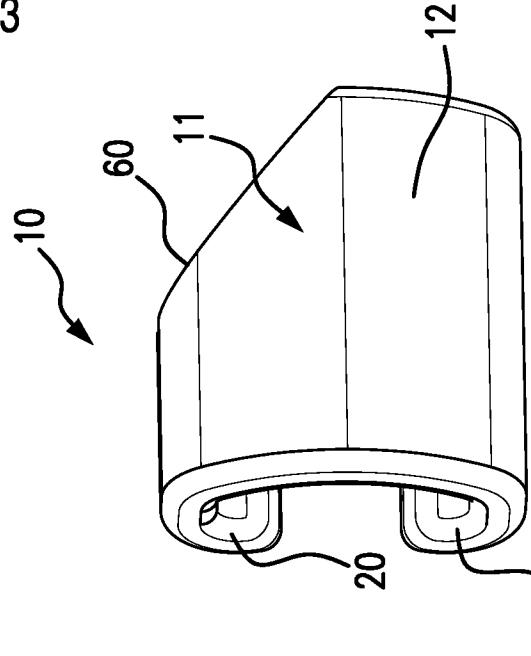

FIG. 19

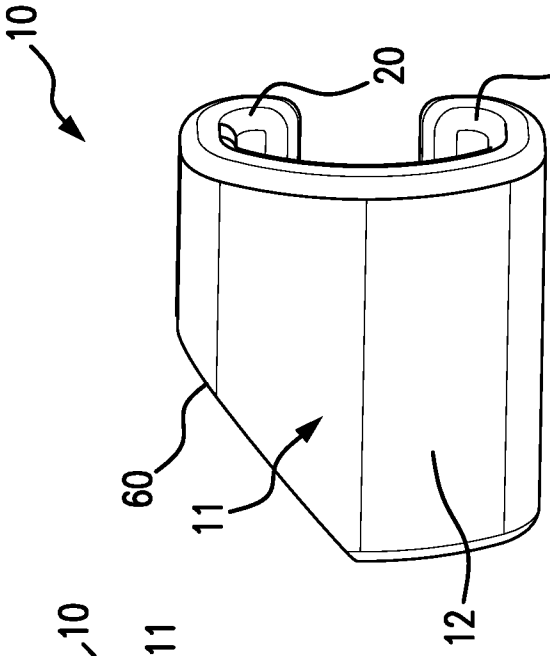

FIG. 18

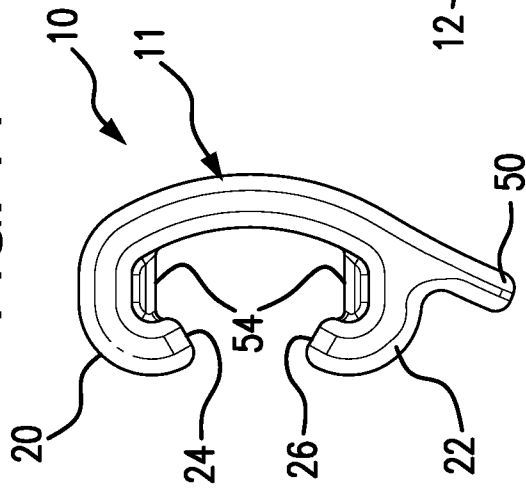

FIG. 17

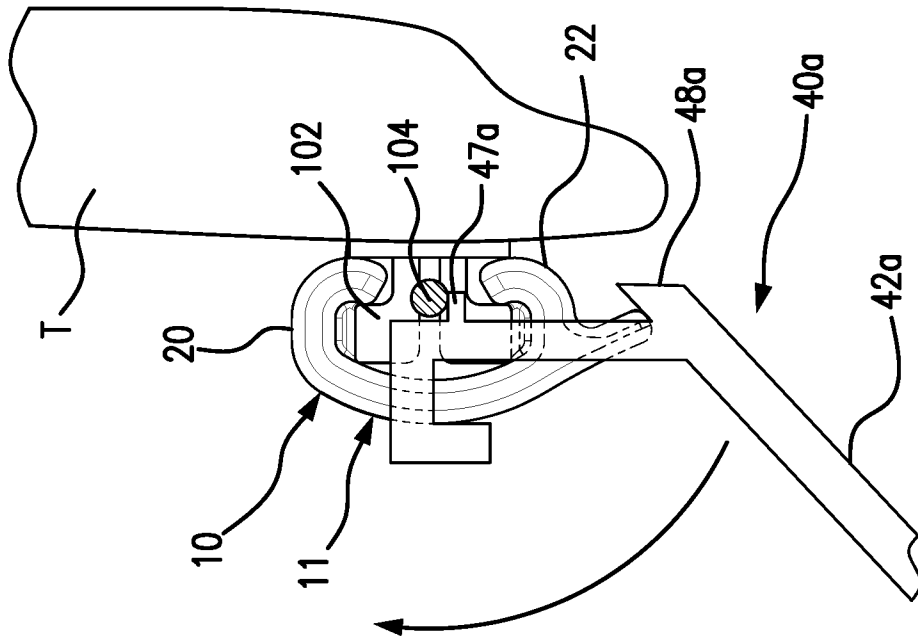

FIG. 21

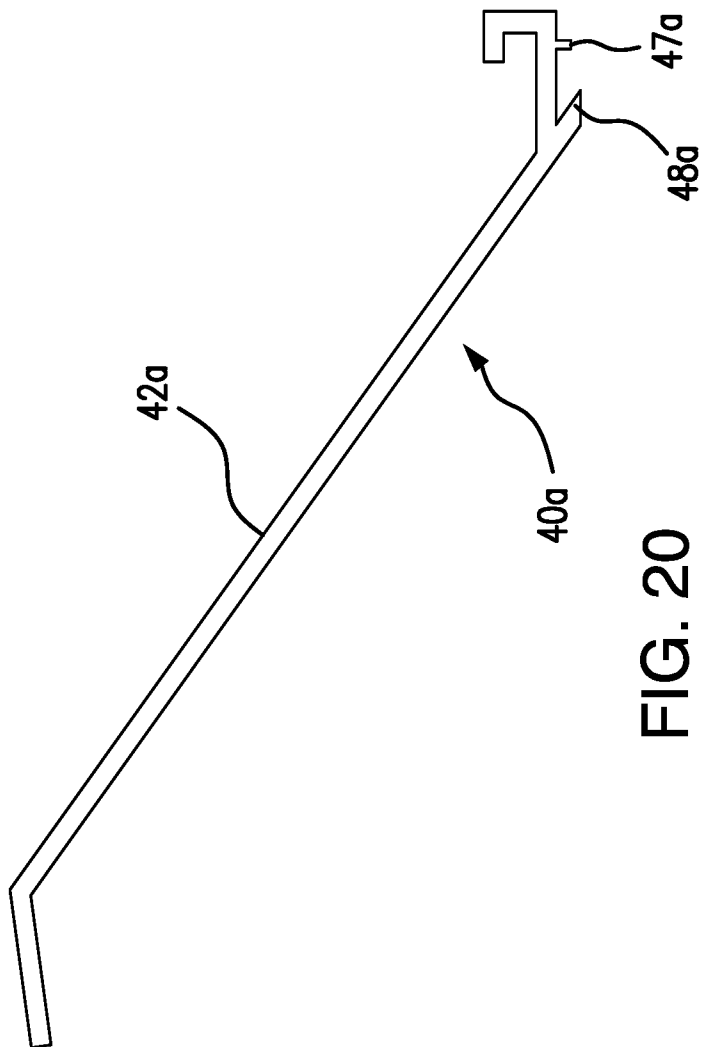

FIG. 20

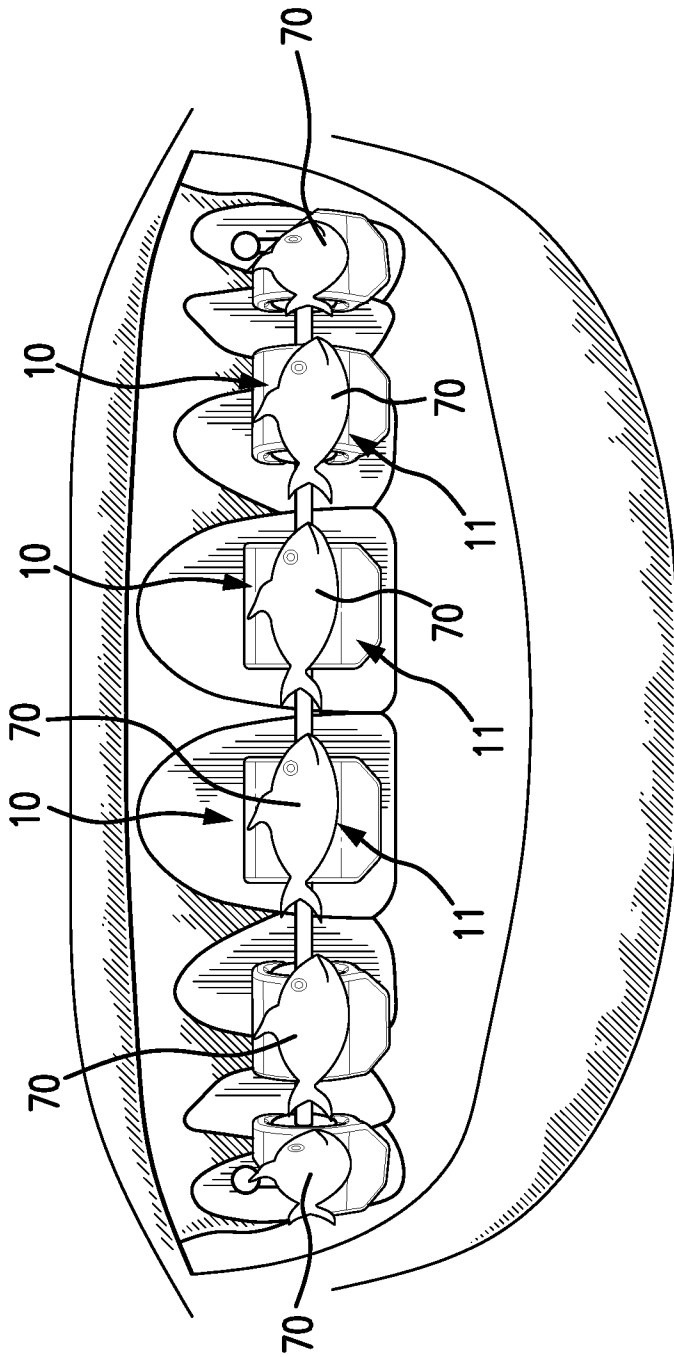

FIG. 22

INTERNATIONAL SEARCH REPORT

International application No.

PCT/US 2018/035091

A. CLASSIFICATION OF SUBJECT MATTER		<i>A61C 7/12 (2006.01)</i>	
According to International Patent Classification (IPC) or to both national classification and IPC			
B. FIELDS SEARCHED		Minimum documentation searched (classification system followed by classification symbols)	
A61C 3/00, 7/12			
Documentation searched other than minimum documentation to the extent that such documents are included in the fields searched			
Electronic data base consulted during the international search (name of data base and, where practicable, search terms used)			
PatSearch (RUPTO internal), Esp@cenet, PAJ, USPTO, Information Retrieval System of FIPS			
C. DOCUMENTS CONSIDERED TO BE RELEVANT			
Category*	Citation of document, with indication, where appropriate, of the relevant passages	Relevant to claim No.	
X	US 2002/0110777 A1 (NORBERT ABELS et al.) 15.08.2002, fig. 16A-B, paragraph [0138]	1, 2, 3, 8, 11, 12, 13, 18	
Y		5, 6, 7, 9, 10, 15, 16, 17, 19, 20	
X	EP 1982669 A1 (ORTHODONTIC MANUFACTURER SIA S.R.L.) 22.10.2008, fig. 1	1, 4, 11, 14	
Y		7, 17	
Y	US 2006/0228663 A1 (STEVEN DARLING et al.) 12.10.2006, fig. 3	9, 19	
Y	US 2006/0292517 A1 (FRED SMITH) 28.12.2006, fig. 2	10, 20	
Y	US 2002/0006595 A1 (JOHN C. VOUDOURIS) 17.01.2002, fig. 3	5, 6, 15, 16	
<input type="checkbox"/> Further documents are listed in the continuation of Box C.		<input type="checkbox"/> See patent family annex.	
* Special categories of cited documents:		“T” later document published after the international filing date or priority date and not in conflict with the application but cited to understand the principle or theory underlying the invention	
“A”	document defining the general state of the art which is not considered to be of particular relevance	“X” document of particular relevance; the claimed invention cannot be considered novel or cannot be considered to involve an inventive step when the document is taken alone	
“E”	earlier document but published on or after the international filing date	“Y” document of particular relevance; the claimed invention cannot be considered to involve an inventive step when the document is combined with one or more other such documents, such combination being obvious to a person skilled in the art	
“L”	document which may throw doubts on priority claim(s) or which is cited to establish the publication date of another citation or other special reason (as specified)	“&” document member of the same patent family	
“O”	document referring to an oral disclosure, use, exhibition or other means		
“P”	document published prior to the international filing date but later than the priority date claimed		
Date of the actual completion of the international search		Date of mailing of the international search report	
08 August 2018 (08.08.2018)		13 September 2018 (13.09.2018)	
Name and mailing address of the ISA/RU: Federal Institute of Industrial Property, Berezhkovskaya nab., 30-1, Moscow, G-59, GSP-3, Russia, 125993 Facsimile No: (8-495) 531-63-18, (8-499) 243-33-37		Authorized officer Yu. Skvortsova Telephone No. (495)531-64-81	