



US 20120319004A1

(19) **United States**

(12) **Patent Application Publication**
Eldering et al.

(10) **Pub. No.: US 2012/0319004 A1**

(43) **Pub. Date: Dec. 20, 2012**

(54) **NANOTUBE ASSISTED SELF-CLEANING MATERIAL**

B01J 37/02 (2006.01)

B05D 5/00 (2006.01)

(75) Inventors: **Charles A. Eldering**, Furlong, PA (US);
Edward A. Ehrlacher, Philadelphia, PA (US)

B82Y 30/00 (2011.01)

B82Y 40/00 (2011.01)

(73) Assignee: **Empire Technology Development LLC**

(52) **U.S. Cl.** **250/453.11**; 423/610; 502/100;
501/32; 427/180; 427/209; 427/402; 977/890;
977/902

(21) Appl. No.: **13/596,380**

(22) Filed: **Aug. 28, 2012**

(57) **ABSTRACT**

Related U.S. Application Data

(63) Continuation of application No. 12/465,717, filed on May 14, 2009, now Pat. No. 8,273,425.

Publication Classification

(51) **Int. Cl.**
C01G 23/047 (2006.01)
C03C 17/23 (2006.01)
A61L 2/08 (2006.01)

A self-cleaning material is generally described that may include a substrate having a first surface. A self-cleaning layer of aligned nanotube structures may be formed on the first surface of the substrate, where absorption of light by the nanotube structures may cause a change in state of the self-cleaning material based on an angle of incidence of the light and an orientation vector corresponding to the layer of aligned nanotube structures.

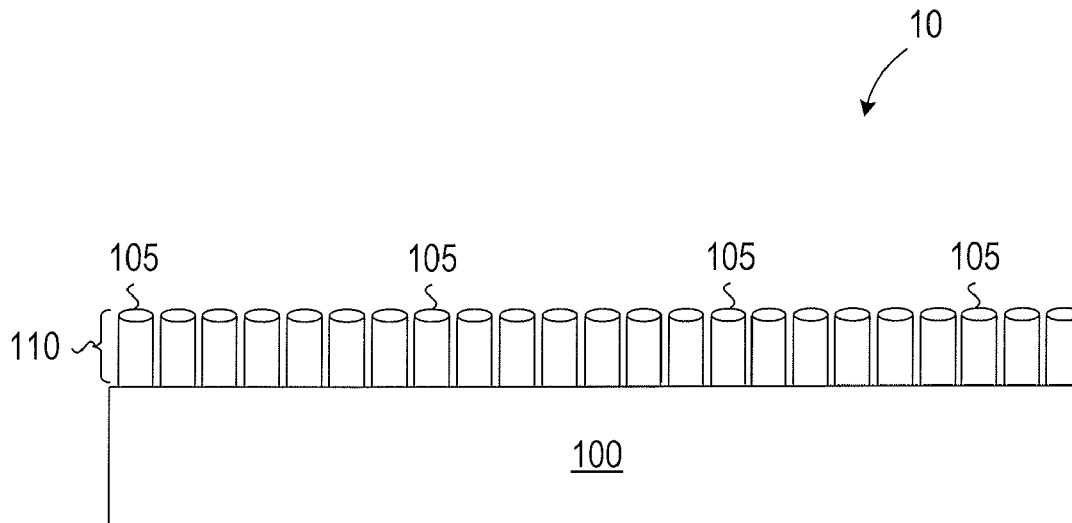

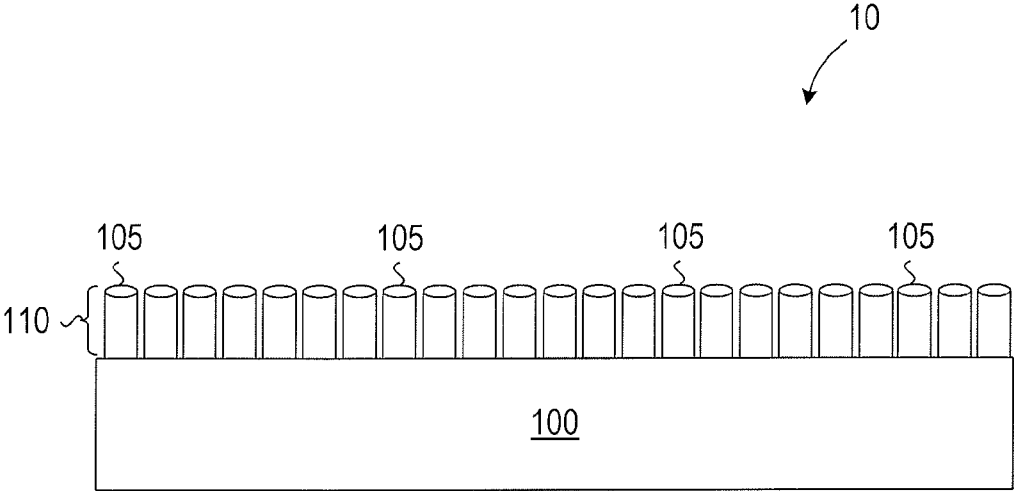

Fig. 1

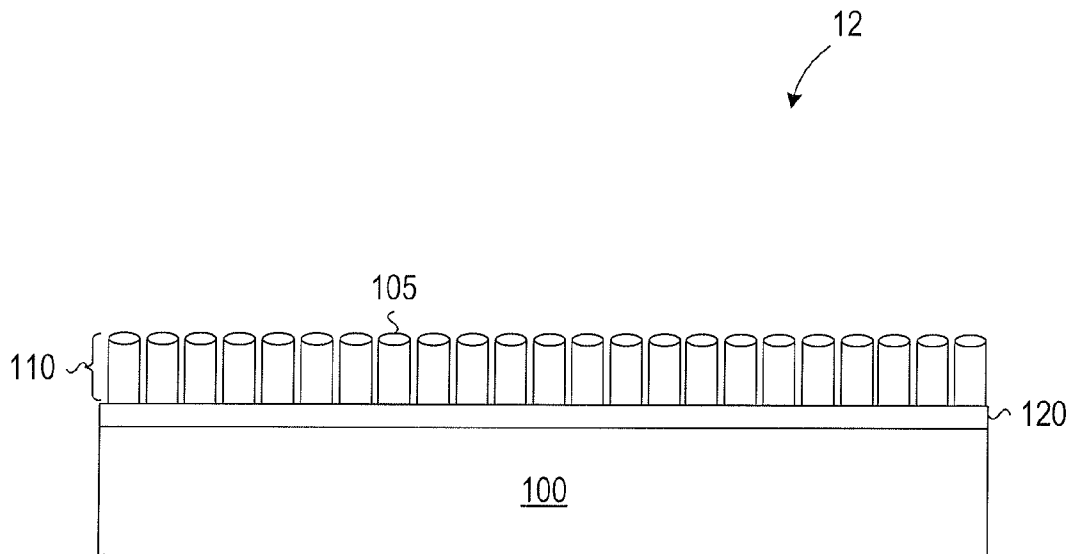

Fig. 2

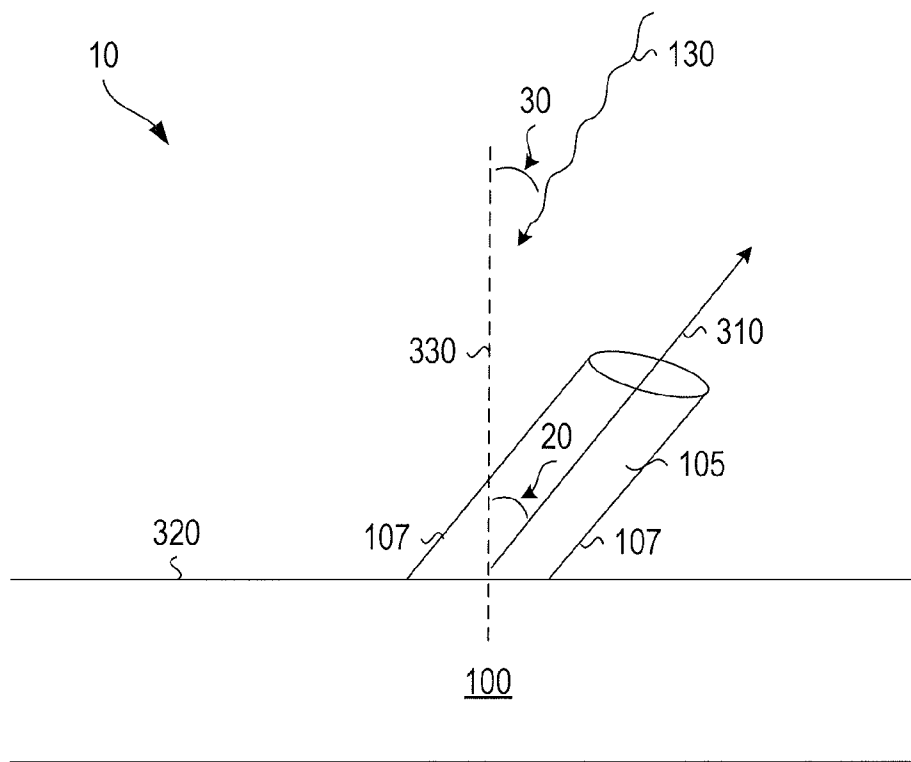

Fig. 3

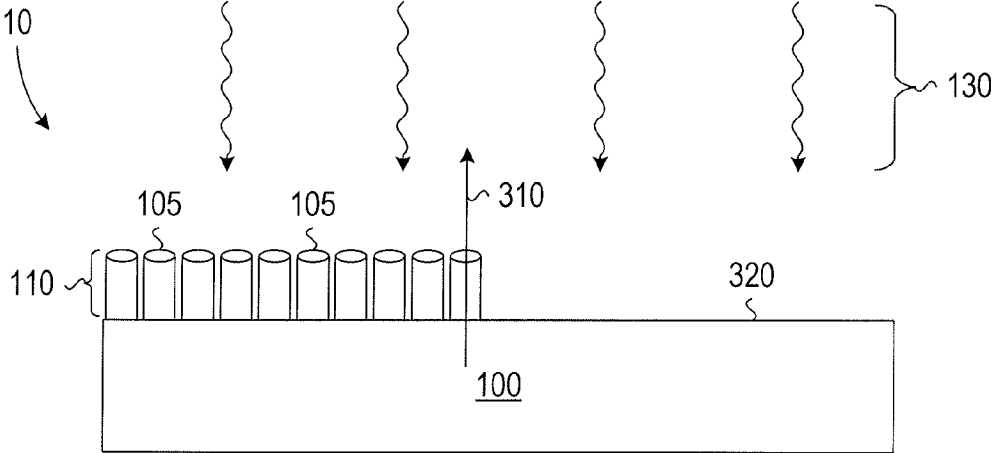

Fig. 4

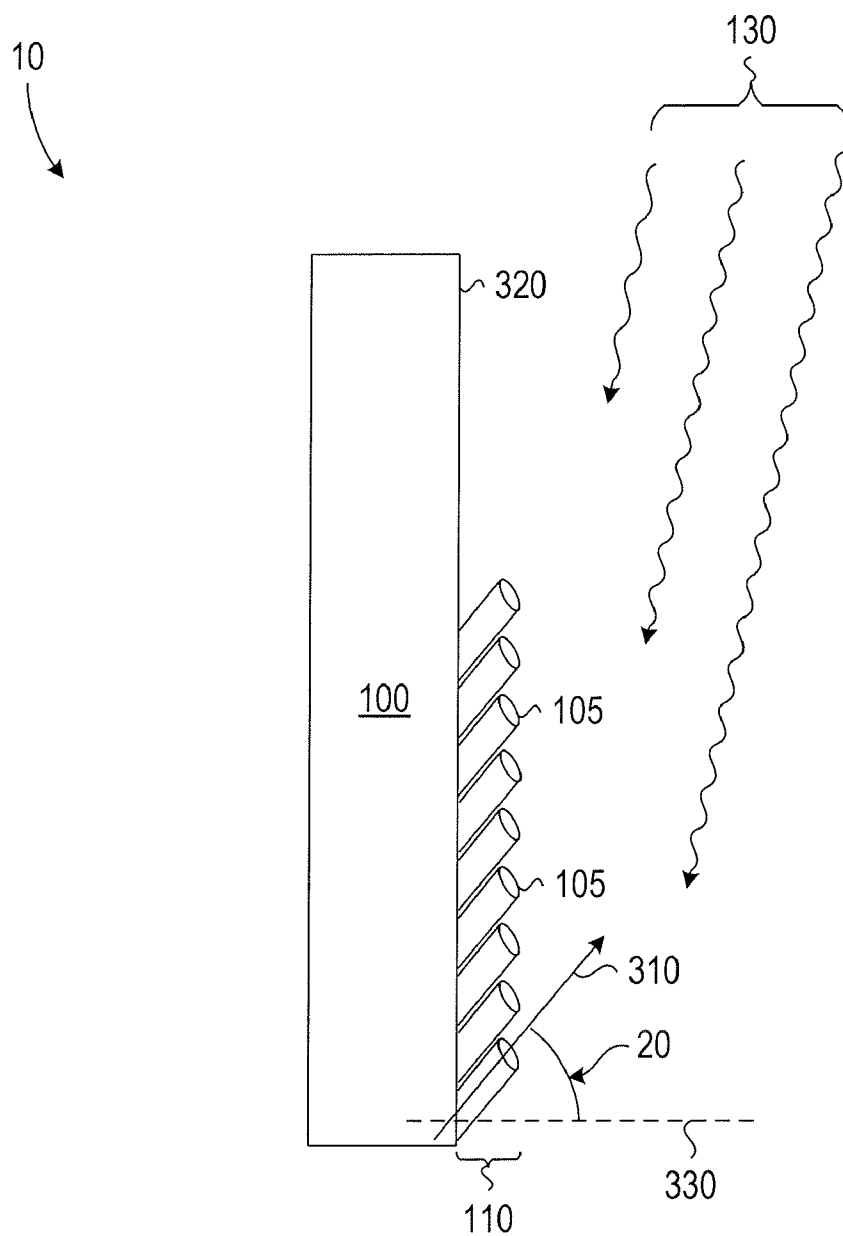

Fig. 5

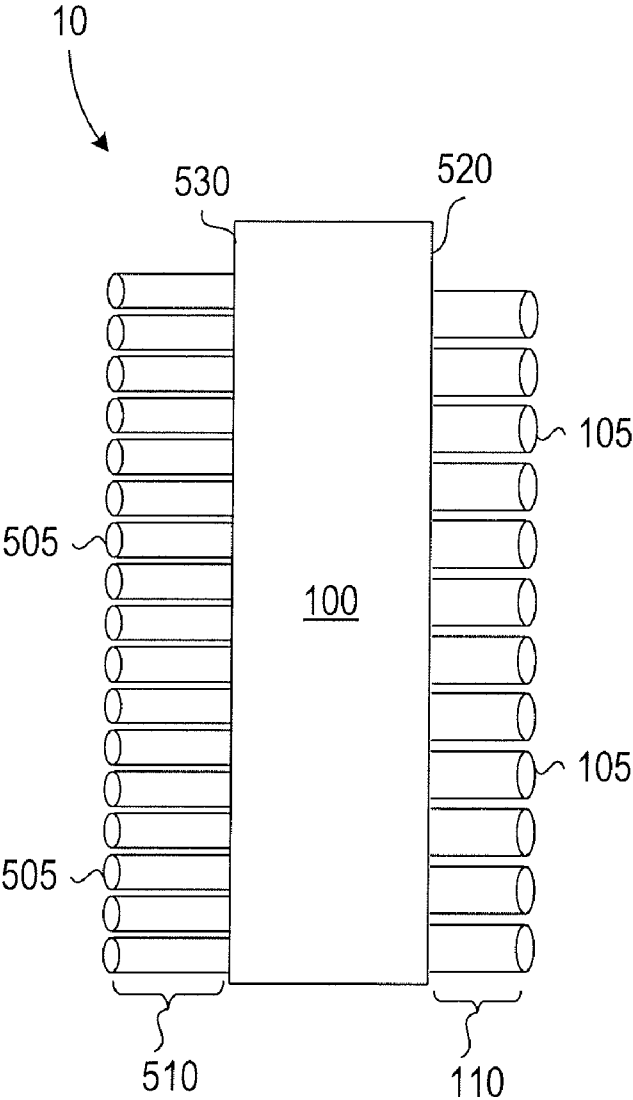

Fig. 6

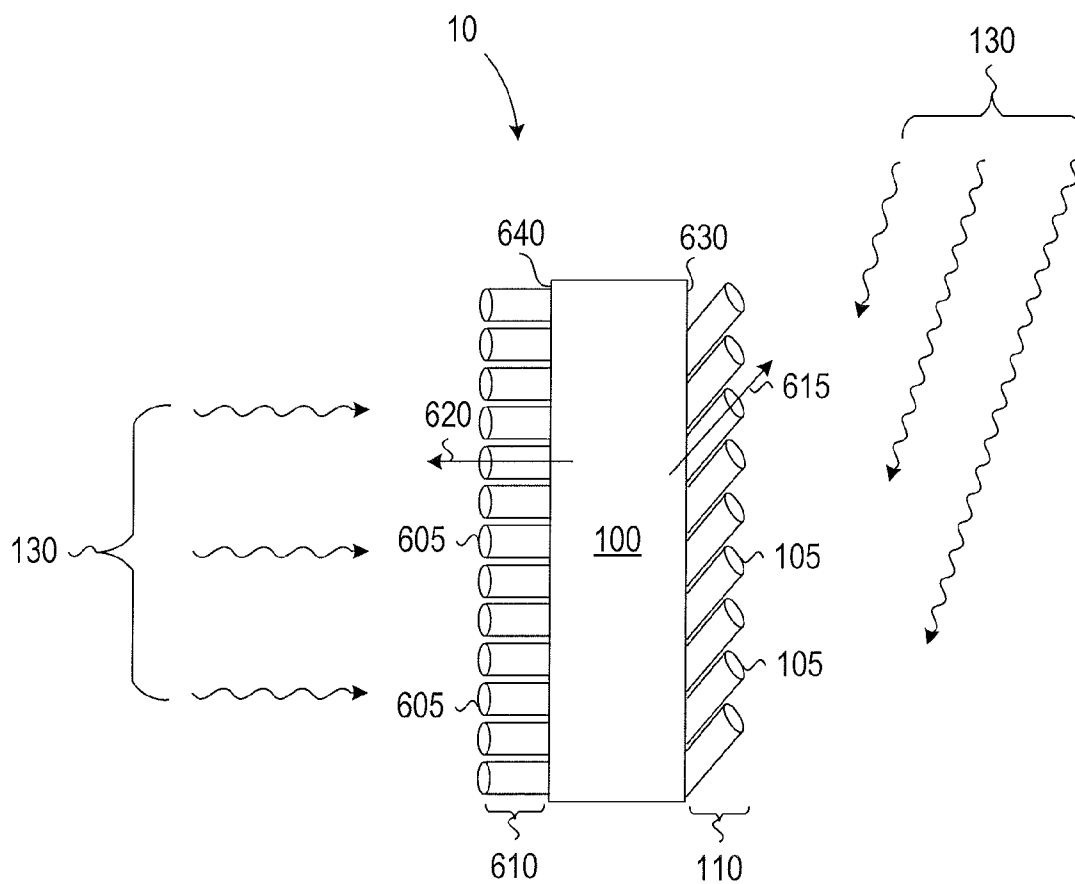

Fig. 7

NANOTUBE ASSISTED SELF-CLEANING MATERIAL

CROSS REFERENCE TO RELATED APPLICATION

[0001] This application is a continuation of U.S. patent application Ser. No. 12/465,717, filed May 14, 2009, entitled Nanotube Assisted Self-Cleaning Material, the entire disclosure of which is incorporated herein by reference.

[0002] This application is related to co-pending U.S. patent application Ser. No. 12/465,711, filed May 14, 2009, entitled Diffraction Grating Assisted Self-Cleaning Material.

BACKGROUND

[0003] The present disclosure relates to self-cleaning materials, and more specifically to materials utilizing self-cleaning layers of aligned nanotubes.

[0004] Self-cleaning materials are effective at keeping products and surfaces clean for long periods of time. Self-cleaning materials are being increasingly utilized for a number of applications including building exteriors, bathrooms, windows, and coatings for various surfaces.

BRIEF DESCRIPTION OF THE DRAWINGS

[0005] The following detailed description will be better understood when read in conjunction with the following description and appended claims, taken in conjunction with the accompanying drawings, in which there is shown one or more of the multiple embodiments of the present disclosure. It should be understood, however, that the various embodiments of the present disclosure are not limited to the precise arrangements and instrumentalities shown in the drawings.

[0006] In the Drawings:

[0007] FIG. 1 is a cross-sectional view illustrating an example self-cleaning material;

[0008] FIG. 2 is a cross-sectional view illustrating an example self-cleaning material with a seed layer;

[0009] FIG. 3 is an enlarged cross-sectional view illustrating an example self-cleaning material showing an example of light incident thereon;

[0010] FIG. 4 is a cross-sectional view illustrating an example self-cleaning material with an orientation vector for nearly normal incident exposure;

[0011] FIG. 5 is a cross-sectional view illustrating an example self-cleaning material with an orientation vector for glancing incident exposure;

[0012] FIG. 6 is a cross-sectional view illustrating an example self-cleaning material where multiple surfaces of the substrate include a self-cleaning layer; and

[0013] FIG. 7 is a cross-sectional view illustrating an example self-cleaning material where multiple surfaces of the substrate include a self-cleaning layer with different orientation vectors; all arranged in accordance with at least some embodiments of the present disclosure.

DETAILED DESCRIPTION

[0014] In the following detailed description, reference is made to the accompanying drawings, which form a part hereof. In the drawings, similar symbols typically identify similar components, unless context dictates otherwise. The illustrative embodiments described in the detailed description, drawings, and claims are not meant to be limiting. Other embodiments may be utilized, and other changes may be

made, without departing from the spirit or scope of the subject matter presented here. It will be readily understood that the aspects of the present disclosure, as generally described herein, and illustrated in the Figures, can be arranged, substituted, combined, and designed in a wide variety of different configurations, all of which are explicitly contemplated and make part of this disclosure.

[0015] Briefly stated, the multiple embodiments of the present disclosure include a self-cleaning material including a substrate having a first surface. A self-cleaning layer of aligned nanotube structures may be formed on the first surface of the substrate, where absorption of light by the nanotube structures may cause a change in state of the self-cleaning material based on an orientation vector corresponding to the layer of aligned nanotube structures.

[0016] A self-cleaning material is disclosed that includes a layer of nanotubes on a substrate. FIG. 1 is a cross-sectional view illustrating an example self-cleaning material 10, arranged in accordance with at least some embodiments of the present disclosure. The self-cleaning material 10 includes a substrate 100 and a self-cleaning layer 110 of nanotubes 105. The nanotubes 105 may be deposited or grown on to a surface of the substrate 100 as discussed in greater detail below. The nanotubes 105 may be formed using a material exhibiting some type of self-cleaning properties when exposed to an appropriate wavelength of light, i.e., the nanotubes 105 may generally exhibit, for example, photocatalytic, photo-induced hydrophilic, or photo-induced hydrophobic properties due to the absorption of photons corresponding to the appropriate wavelength of the light incident on the self-cleaning layer 110. For example, self-cleaning properties of some self-cleaning materials, such as titanium dioxide (TiO_2), are enhanced or activated in response to light in the ultraviolet region of the spectrum, while other self-cleaning materials, such as nickel doped indium tantalate ($\text{In}_{(1-x)}\text{Ni}_x\text{TaO}_4$), may be responsive to light in the visible region of the spectrum. The activation or enhancement of the photocatalytic, photo-induced hydrophilic, or photo-induced hydrophobic self-cleaning properties of the self-cleaning layer 110 may also be referred to as a change of state of the self-cleaning layer 110. The change of state may also include a switching from one of the self-cleaning properties to a different self-cleaning property. The exposure to, and resulting absorption of, the light may also cause the nanotubes 105 to exhibit more than one of these properties. For example, the nanotubes 105 may become both photocatalytic and hydrophilic, as will be understood in light of the present disclosure. In some embodiments, the nanotubes 105 may be oriented with respect to the surface of the substrate 100 to enhance light absorption by the nanotubes 105 and thus may enhance or activate the self-cleaning properties. In some embodiments, the nanotubes 105 may be substantially parallel with respect to each other. The orientation of the nanotubes 105 with respect to the surface of the substrate 100 may be described using an orientation vector (not shown in FIG. 1), described in more detail below.

[0017] In the present disclosure, the self-cleaning material 10 may include the structure of the substrate 100 and the self-cleaning layer 110 of the nanotubes 105 in combination. While the substrate 100 alone may not necessarily exhibit cleaning properties, for convenience, the particular substrates 100 referred to herein as self-cleaning are understood to be in combination with a self-cleaning layer 110, such that the combined structure exhibits self-cleaning properties. For

example, a glass substrate with a layer of TiO₂ nanotubes may be referred to herein simply as self-cleaning glass. In some embodiments, the substrate **100** in the absence of the self-cleaning layer **110** of nanotubes **105** may, under some conditions, exhibit self-cleaning properties (i.e., the substrate may itself be a self-cleaning material), with the self-cleaning layer **110** of nanotubes **105** being used to enhance or change the self-cleaning properties of the substrate **100**.

[0018] The substrate **100** may be any base material for which self-cleaning properties are desired. Some examples of substrates include glass, ceramics, metals, composites, or other building materials. The nanotubes **105** may be any material exhibiting self-cleaning properties generally known in the art, such as titanium dioxide (also known as TiO₂ and titania) or nickel doped indium tantalate (In_(1-x)Ni_xTaO₄). Methods of nanotube formation, such as chemical vapor deposition (CVD) and pre-cursor templating may be utilized, although a detailed discussion thereof is omitted here for convenience only and should not be considered limiting. Furthermore, techniques for depositing aligned layers of nanotubes on a surface, such as Langmuir-Blodgett deposition, self-assembly processes, and sputtering in an electromagnetic field, is also omitted here for convenience only and should not be considered limiting. In some embodiments, the nanotubes **105** may generally be single walled, aligned structures, although the self-cleaning materials **10** described herein are not limited to such arrangements. The self-cleaning layer **110** of nanotubes **105** may be transparent with respect to the substrate **100**, and may conform to contours of the substrate **100** such that the self-cleaning layer **110** of nanotubes **105** may largely be indistinguishable with respect to the substrate **100**. In addition, the substrate **100** may include a self-cleaning layer of nanotubes on one or more surfaces of the substrate.

[0019] In the embodiments of the present disclosure, the self-cleaning materials **10** may be used in a controlled or uncontrolled environment. A controlled environment may generally refer to a space where environmental parameters can be controlled and stabilized (e.g., indoors or an otherwise enclosed area), and may generally be free from exposure to weather or other volatile conditions. Environmental parameters may include but are not limited to temperature, humidity, and illumination. In contrast, an uncontrolled environment may generally refer to a space where the environmental parameters are not readily controlled (e.g., outdoors), and surfaces may be exposed to weather conditions. In some embodiments, one surface of the self-cleaning material **10** may be exposed to a controlled environment, and another surface of the self-cleaning material **10** may be exposed to an uncontrolled environment. One example is a self-cleaning window (not shown), where one surface of the window may be an exterior surface and the other surface of the window may be an interior surface.

[0020] Incident light, or simply light, may refer to the electromagnetic radiation in the visible, ultraviolet, and infrared regions of the electromagnetic spectrum impinging on a surface of the self-cleaning material **10**. The exposure of a surface to light may also be referred to herein as illuminating or illumination of the surface in question. Illumination characteristics for a surface may include one or more of angle of incidence of the incident light, intensity of the incident light, wavelength distribution of the incident light, and/or the intensity distribution as a function of the wavelength.

[0021] The angle of incidence of the incident light may be measured from an axis perpendicular to (i.e., normal to) the surface of the self-cleaning material. An angle of incidence of zero (i.e., normal incidence) may refer to the illumination condition where the incident light impinges on the surface of the self-cleaning material **10** substantially perpendicular to the surface. Glancing incidence may refer to illumination of the self-cleaning material where the angle of incidence approaches 90 degrees (i.e., nearly parallel to the surface of the self-cleaning material). Since light impinging on the self-cleaning material may not be exactly collimated or collinear, the angle of incidence may refer to the angle with the highest total intensity of light illuminating the surface. For example, illumination of a surface by direct sunlight may tend to have a higher total intensity than sunlight scattered onto the surface from other objects; thus, the angle of incidence may be measured using the incident light from the sun.

[0022] In view of the present disclosure, it will be appreciated that illumination (also referred to as exposure) of the surface of the self-cleaning material **10** may be dependent on the environment. In an uncontrolled environment, such as outdoors, the illumination characteristics may be variable—dependent on time of day, season, proximate natural and man-made objects, and latitude—as the electromagnetic radiation from the sun reaching the surface of the earth may be dependent on one or more of these variables. Conversely, in a controlled environment, such as an interior space with fixed lighting, the illumination characteristics may generally be dependent on the type and positioning of the lighting fixtures, with little variability other than switching on/off the lighting, using a light dimmer, or changing the type or wattage of the light bulbs, etc.

[0023] FIG. 2 is a cross-sectional view illustrating an example self-cleaning material **12** that includes a seed layer **120**, arranged in accordance with at least some embodiments of the present disclosure. In some embodiments, a seed layer **120** is deposited on the substrate **100** before the nanotubes **105** are grown. The seed layer **120** is a thin film that acts as a template for growth of the nanotubes **105** that form the self-cleaning layer **110**. Growth of layers **110** of aligned nanotube structures **105** on a substrate **100** are well known in the art, and detailed discussion thereof is omitted here for convenience only and should not be considered limiting.

[0024] FIG. 3 is an enlarged cross-sectional view of an example self-cleaning material **10** showing an example of light incident thereon, arranged in accordance with at least some embodiments of the present disclosure. Similar to the example of FIG. 1, the self-cleaning material **10** may include a substrate **100** and a layer of nanotubes **105**. The nanotubes **105** may be disposed on a surface **320** of the substrate **100** at an orientation angle **20** with respect to the surface **320** (for convenience only, a single nanotube **105** is shown in FIG. 3). An orientation vector **310** may be defined along an axis (not shown) substantially parallel to the sidewalls **107** of the aligned nanotubes **105**. The orientation angle **20** may be the angle formed by the axis **330** that is normal to the surface **320** of the substrate **100** and the orientation vector **310**. Light **130** incident on the nanotubes **105** having an angle of incidence **30** (measured with respect to the axis **330**) may be absorbed by the nanotubes **105** to activate the self-cleaning properties of the self-cleaning layer **110** (see FIG. 1). In some embodiments, the self-cleaning properties of the self-cleaning layer **110** may be enhanced as the angle of incidence **30** approaches the orientation angle **20** (i.e., as the incident light **130**

becomes more nearly parallel to the orientation vector **310**. In some embodiments, if the angle of incidence **20** is not matched to the orientation angle **30**, the absorption of the incident light **130** by the nanotubes **105** may be insufficient to activate the photo-induced self-cleaning properties of the self-cleaning material **10**.

[0025] FIG. 4 is a cross-sectional view illustrating an example self-cleaning material **10** having an orientation vector **310** selected for nearly normal incident exposure of the light **130**, arranged in accordance with at least some embodiments of the present disclosure. The orientation vector **310**, as described above with respect to FIG. 3, may correspond to the orientation of the nanotubes **105** with respect to the surface **320** of the substrate **10**. For an illumination condition where the incident light **130** may be perpendicular (i.e., normal incidence) or nearly perpendicular to the surface **320** (i.e., low angle of incidence), the self-cleaning properties of the self-cleaning layer **110** may be enhanced when the orientation vector **310** is perpendicular or nearly perpendicular to the surface **320** (i.e., small orientation angle) and the orientation vector **310** is nearly parallel to incident light **130**. For example, a self-cleaning ceramic tile may be used in a horizontal orientation, such as on a floor or other horizontal surface. For light sources such as the sun outdoors or ceiling lighting fixtures indoors, the angle of incidence of the light illuminating the surface of the tile may nearly be normal to the surface. Thus, a self-cleaning material **10** having an orientation vector **310** for the nanotubes **105** with a small orientation angle **20** (see FIG. 3) may provide efficient self-cleaning properties.

[0026] FIG. 5 is a cross-sectional view illustrating an example self-cleaning material **10** having an orientation vector **310** selected for glancing incident exposure of the light **130**, arranged in accordance with at least some embodiments of the present disclosure. The orientation vector **310**, as described above with respect to FIG. 3, corresponds to the orientation of the nanotubes **105** with respect to the surface **320** of the substrate **10**. For an illumination condition where the incident light **130** may be substantially parallel to the surface **320** (i.e., glancing incidence or high angle of incidence), the self-cleaning properties of the self-cleaning layer **110** may be enhanced when the orientation vector **310** is nearly parallel to the surface **320** (i.e., large orientation angle **20**), and the orientation vector **310** is nearly parallel to incident light **130**. For example, for a self-cleaning ceramic tile used in a vertical orientation such as mounted on a wall under the same illumination conditions as previously described with respect to the example of FIG. 4, the angle of incidence **30** (see FIG. 3) of the light illuminating the surface may be high, even approaching glancing incidence. A self-cleaning material **10** with an orientation vector **310** for the nanotubes **105** having a large orientation angle **20** may thus provide the efficient self-cleaning properties for the self-cleaning ceramic tile in the vertical orientation.

[0027] FIG. 6 is a cross-sectional view illustrating an example self-cleaning material **10** where multiple surfaces **520, 530** of the substrate **100** include self-cleaning layers **110, 510**, respectively, in accordance with at least some embodiments of the present disclosure. Self-cleaning layer **110** may include nanotubes **105** formed on a first surface **520** of the substrate **100**. Self-cleaning layer **510** may include nanotubes **505** formed on a second surface **530** of the substrate **100**. The depiction of the surfaces **520, 530** as parallel or on opposite sides of the substrate **100** in FIG. 6 should not be considered

limiting. For example, for a cubic substrate (not shown), two adjacent surfaces of the cube may have a self-cleaning layer (e.g., a block of building material on the corner has two adjacent exterior sides). Likewise, some embodiments may include a self-cleaning material **10** where more than two surfaces of the substrate may have a self-cleaning layer.

[0028] Still referring to FIG. 6, the nanotubes **105, 505** of the self-cleaning layers **110, 510** may be the same material, or alternately the nanotubes **105** of the self-cleaning layer **110** may be a different material than the nanotubes **505** of the self-cleaning layer **510**. In some embodiments, the nanotubes **105, 505** may be selected based on the type of environment or the self-cleaning properties desired for each surface **520, 530** of the self-cleaning material **10**. For example, one surface of the self-cleaning material **10** may be exposed to a controlled environment, while another surface of the self-cleaning material may be exposed to an uncontrolled environment. In the controlled environment, photocatalytic properties used to disinfect the surfaces of the controlled environment may be important, while in the uncontrolled environment, hydrophilic properties may be more important to keep the surface from soiling.

[0029] FIG. 7 is a cross-sectional view illustrating an example self-cleaning material **10** where multiple surfaces **630, 640** of the substrate **100** include a self-cleaning layer **110, 610** having different orientation vectors **615, 620**, respectively, in accordance with at least some embodiments of the present disclosure. Self-cleaning layer **110** includes nanotubes **105** formed on a first surface **630** of the substrate **100** having a first orientation vector **615**. Self-cleaning layer **610** includes nanotubes **605** formed on a second surface **640** of the substrate **100** having a second orientation vector **620**. As discussed above with respect to FIG. 6, the depiction of the surfaces **630, 640** as parallel or on opposite sides of the substrate **100** in FIG. 7 should not be considered limiting. Likewise, some embodiments may include a self-cleaning material **10** where more than two surfaces of the substrate may have a self-cleaning layer.

[0030] Still referring to FIG. 7, the nanotubes **105, 605** of the self-cleaning layers **110, 610** may be the same material, or alternately the nanotubes **105** of self-cleaning layer **110** may be a different material than the nanotubes **605** of self-cleaning layer **610**. The orientation vectors **615, 620** may be selected based on the expected or most probable illumination conditions of their respective surfaces **630, 640**. Thus, in the embodiments of FIG. 7, for example, the orientation angle **20** (see FIG. 3) associated with the first orientation vector **615** may be noticeably larger than the orientation angle **20** associated with the second orientation vector **620**. In FIG. 7, the second surface **640** of the self-cleaning material **10** may most typically be illuminated with light **130** of normal incidence; thus, an orientation vector **620** with a low orientation angle **20** is used. In contrast, for the first surface **630** of the self-cleaning material **10**, the most typical illumination may be glancing incidence, and an orientation vector **615** with a high orientation angle may be used. For example, for a self-cleaning material used in a vertical orientation (e.g., self-cleaning glass used in a window), the direct illumination of the exterior surface of the window by sunlight may be considered as glancing illumination (a very high angle of incidence), while the illumination of the interior side of the window by interior light fixtures may have much lower angles of incidence.

[0031] The herein described subject matter sometimes illustrates different components contained within, or con-

nected with, different other components. It is to be understood that such depicted architectures are merely exemplary, and that in fact many other architectures can be implemented which achieve the same functionality. In a conceptual sense, any arrangement of components to achieve the same functionality is effectively “associated” such that the desired functionality is achieved. Hence, any two components herein combined to achieve a particular functionality can be seen as “associated with” each other such that the desired functionality is achieved, irrespective of architectures or intermedial components. Likewise, any two components so associated can also be viewed as being “operably connected”, or “operably coupled”, to each other to achieve the desired functionality, and any two components capable of being so associated can also be viewed as being “operably couplable”, to each other to achieve the desired functionality. Specific examples of operably couplable include but are not limited to physically mateable and/or physically interacting components and/or wirelessly interactable and/or wirelessly interacting components and/or logically interacting and/or logically interactable components.

[0032] With respect to the use of substantially any plural and/or singular terms herein, those having skill in the art can translate from the plural to the singular and/or from the singular to the plural as is appropriate to the context and/or application. The various singular/plural permutations may be expressly set forth herein for sake of clarity.

[0033] It will be understood by those within the art that, in general, terms used herein, and especially in the appended claims (e.g., bodies of the appended claims) are generally intended as “open” terms (e.g., the term “including” should be interpreted as “including but not limited to;” the term “having” should be interpreted as “having at least;” the term “includes” should be interpreted as “includes but is not limited to;” etc.). It will be further understood by those within the art that if a specific number of an introduced claim recitation is intended, such an intent will be explicitly recited in the claim, and in the absence of such recitation no such intent is present. For example, as an aid to understanding, the following appended claims may contain usage of the introductory phrases “at least one” and “one or more” to introduce claim recitations. However, the use of such phrases should not be construed to imply that the introduction of a claim recitation by the indefinite articles “a” or “an” limits any particular claim containing such introduced claim recitation to inventions containing only one such recitation, even when the same claim includes the introductory phrases “one or more” or “at least one” and indefinite articles such as “a” or “an” (e.g., “a” and/or “an” should typically be interpreted to mean “at least one” or “one or more”); the same holds true for the use of definite articles used to introduce claim recitations. In addition, even if a specific number of an introduced claim recitation is explicitly recited, those skilled in the art will recognize that such recitation should typically be interpreted to mean at least the recited number (e.g., the bare recitation of “two recitations,” without other modifiers, typically means at least two recitations, or two or more recitations). Furthermore, in those instances where a convention analogous to “at least one of A, B, and C, etc.” is used, in general such a construction is intended in the sense one having skill in the art would understand the convention (e.g., “a system having at least one of A, B, and C” would include but not be limited to systems that have A alone, B alone, C alone, A and B together, A and C together, B and C together, and/or A, B, and C together, etc.).

It will be further understood by those within the art that virtually any disjunctive word and/or phrase presenting two or more alternative terms, whether in the description, claims, or drawings, should be understood to contemplate the possibilities of including one of the terms, either of the terms, or both terms. For example, the phrase “A or B” will be understood to include the possibilities of “A” or “B” or “A and B.” **[0034]** While various aspects and embodiments have been disclosed herein, other aspects and embodiments will be apparent to those skilled in the art. The various aspects and embodiments disclosed herein are for purposes of illustration and are not intended to be limiting, with the true scope and spirit being indicated by the following claims.

What is claimed is:

1. A method of making a self-cleaning material, the method comprising:

providing a substrate having a first surface; and forming a first self-cleaning layer of longitudinally aligned nanotube structures on the first surface of the substrate, wherein longitudinal axes of the nanotube structures are parallel to each other and form a first non-zero acute orientation angle with respect to an axis normal to the first surface.

2. The method of claim 1, wherein the forming the first self-cleaning layer includes growing the nanotube structures on the substrate.

3. The method of claim 1, wherein the forming the first self-cleaning layer includes depositing the nanotube structures on the substrate.

4. The method of claim 1, wherein the first self-cleaning layer changes state responsive to an exposure to light based at least in part on an angle of incidence of the light and the first orientation angle.

5. The method of claim 4, wherein the first self-cleaning layer is further arranged such that absorption of light by the self-cleaning layer of aligned nanotube structures increases as the angle of incidence of the light approaches the first orientation angle.

6. The method of claim 1, wherein the self-cleaning layer of aligned nanotube structures is photocatalytic, hydrophobic, and/or hydrophilic in response to exposure to the light.

7. The method of claim 1, wherein the nanotube structures are a different material than the substrate.

8. The method of claim 7, wherein the nanotube structures at least partially comprise titanium dioxide and the substrate is a glass.

9. The method of claim 1, further comprising:

forming a second self-cleaning layer of longitudinally aligned nanotube structures on a second surface of the substrate, wherein second longitudinal axes of the nanotube structures of the second self-cleaning layer are parallel to each other and form a second non-zero acute orientation angle with respect to an axis normal to the second surface.

10. The method of claim 9, wherein the nanotube structures of the first self-cleaning layer and the nanotube structures of the second self-cleaning layer are different materials.

11. The method of claim 10, wherein the second self-cleaning layer exhibits a different self-cleaning property than the first self-cleaning layer.

12. The method of claim 10, wherein the first orientation angle is selected based on the first self-cleaning layer being utilized in an uncontrolled environment and the second ori-

entation angle is selected based on the second self-cleaning layer being utilized in a controlled environment.

13. A method of making a self-cleaning material, the method comprising:

- providing a substrate having a first surface;
- depositing a seed layer on the first surface of the substrate; and
- forming a self-cleaning layer of longitudinally aligned nanotube structures on the seed layer, wherein longitudinal axes of the nanotube structures are parallel to each other and form a non-zero acute orientation angle with respect to an axis normal to the first surface.

14. The method of claim **13**, wherein the forming the first self-cleaning layer includes growing the nanotube structures on the substrate.

15. The method of claim **13**, wherein the seed layer is a different material than the substrate.

16. The method of claim **13**, wherein the self-cleaning layer changes state responsive to an exposure to light based at least in part on an angle of incidence of the light and the orientation angle.

17. The method of claim **16**, wherein the self-cleaning layer is further arranged such that absorption of light by the self-cleaning layer of the aligned nanotube structures increases as the angle of incidence of the light approaches the orientation angle.

18. A method of using a self-cleaning material, the method comprising:

- attaching the self cleaning material to a support structure, the self cleaning material comprising:
 - a substrate having a first surface, and
 - a self-cleaning layer of longitudinally aligned nanotube structures on the first surface of the substrate, wherein longitudinal axes of the nanotube structures are parallel to each other and form a non-zero acute orientation angle with respect to an axis normal to the first surface; and

- illuminating the self-cleaning material with light, the illuminating causing the self-cleaning layer to change state responsive to exposure to the light based at least in part on an angle of incidence of the light and the orientation angle.

19. The method of claim **18**, wherein the support structure is included in an uncontrolled environment, and the orientation angle of the nanotube structures is selected based upon environmental parameters.

20. The method of claim **18**, wherein the support structure is included in a controlled environment, and the orientation angle is selected to match the angle of incidence of the light from of a fixture illuminating the self-cleaning material.

* * * * *