



(19) **United States**

(12) **Patent Application Publication**
AOKI

(10) **Pub. No.: US 2011/0305600 A1**

(43) **Pub. Date: Dec. 15, 2011**

(54) **MICROCHIP SOLUTION SENDING SYSTEM**

(52) **U.S. Cl.** 422/82.08; 422/68.1

(75) **Inventor:** Youichi AOKI, Tokyo (JP)

(57) **ABSTRACT**

(73) **Assignee:** KONICA MINOLTA HOLDINGS, INC., Tokyo (JP)

[Technical Problem]

(21) **Appl. No.:** 13/153,868

It is an object to provide a microchip solution sending system that is provided with the high reaction efficiency and the high detection accuracy.

(22) **Filed:** Jun. 6, 2011

[Solution of Problem]

(30) **Foreign Application Priority Data**

Jun. 9, 2010 (JP) 2010-131970

A microchip solution sending system comprises a fine flow passage that is provided with a reaction field to which an antibody that reacts with a specific antigen is fixed and a solution sending pump that is configured to send a specimen material solution that includes the specific antigen, wherein a specimen material solution passes through a reaction field of a fine flow passage in a repetitive manner in the case in which the solution sending pump sends the specimen material solution, and a flow rate of a specimen material solution that is sent by the solution sending pump is in the range of 1,000 μ l/min to 50,000 μ l/min.

Publication Classification

(51) **Int. Cl.**
G01N 21/64 (2006.01)
G01N 33/50 (2006.01)

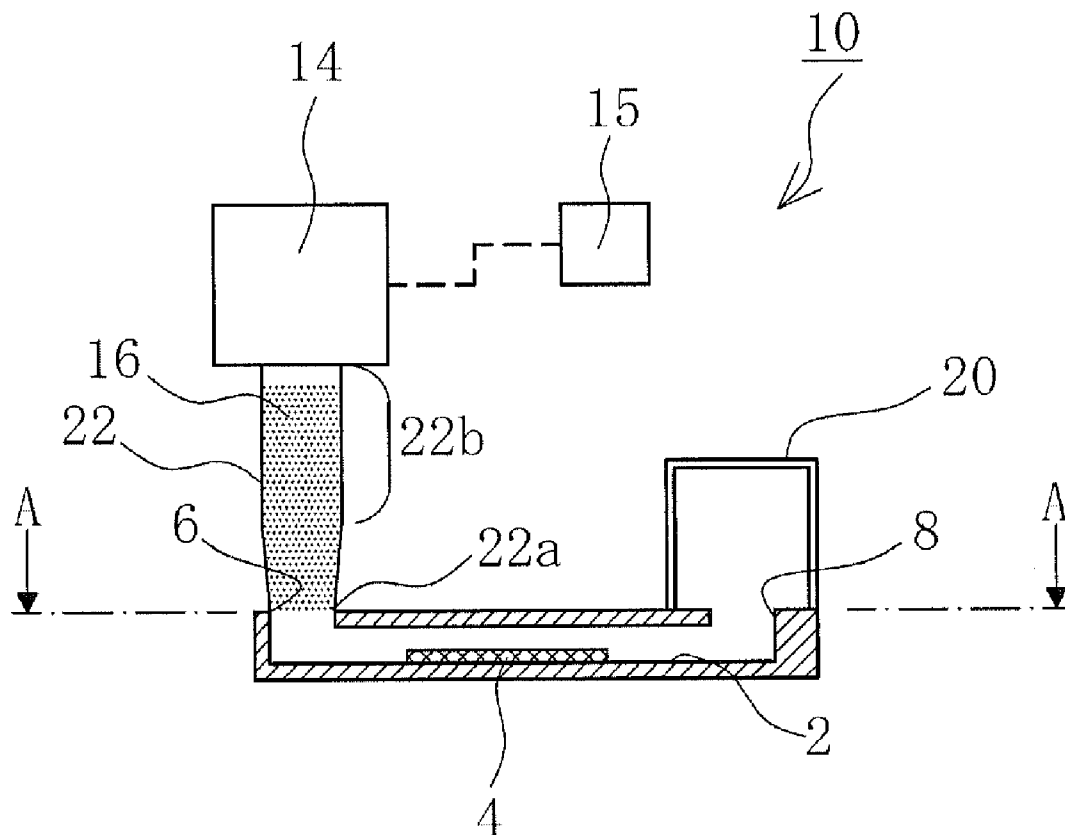

[Fig. 1]

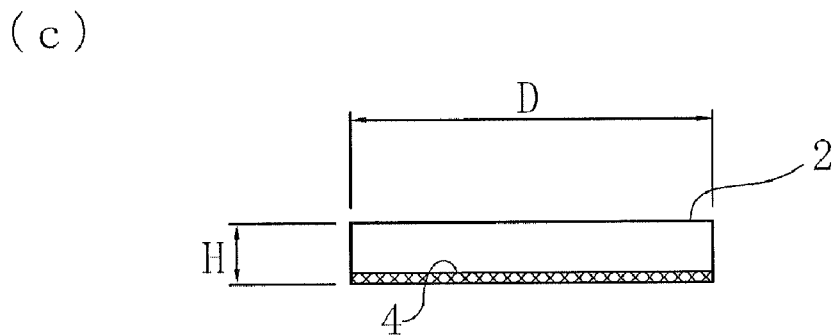
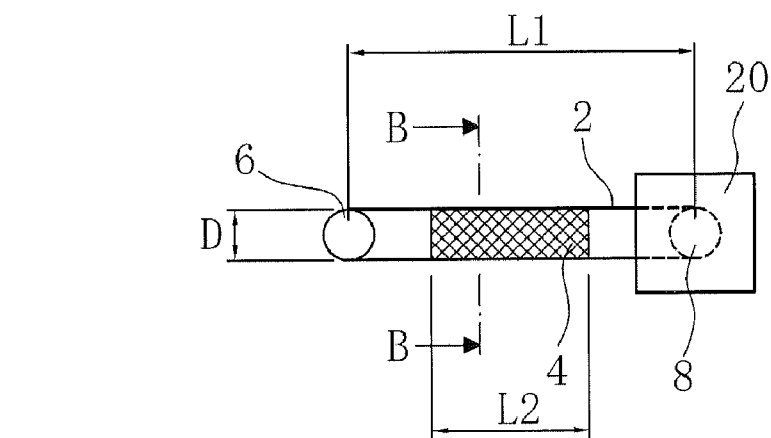
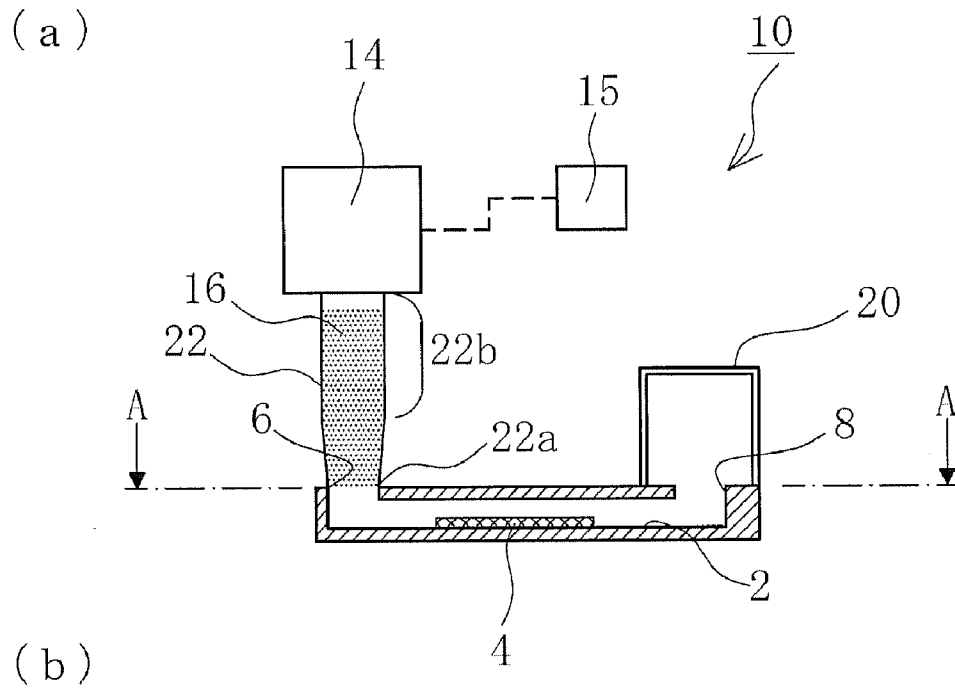

[Fig. 2]

(a)

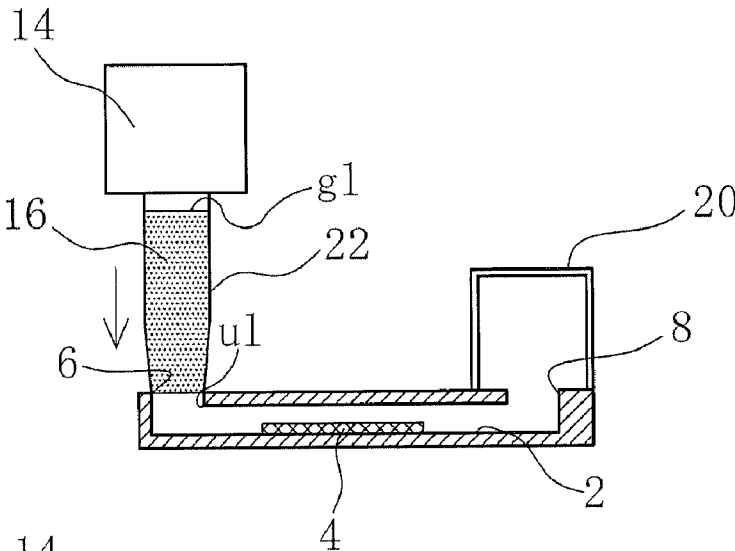

(b)

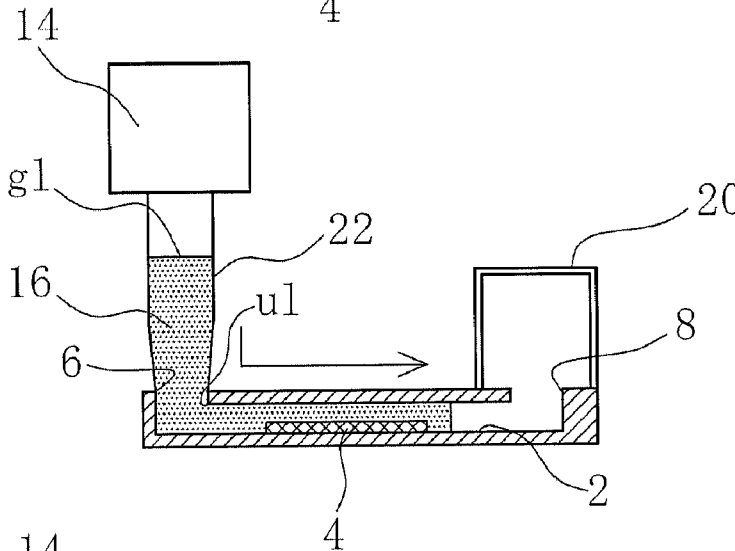

(c)

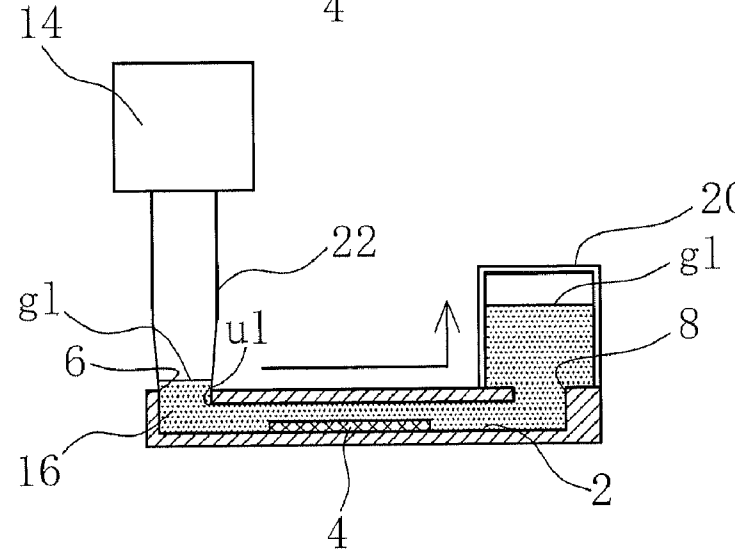

[Fig. 3]

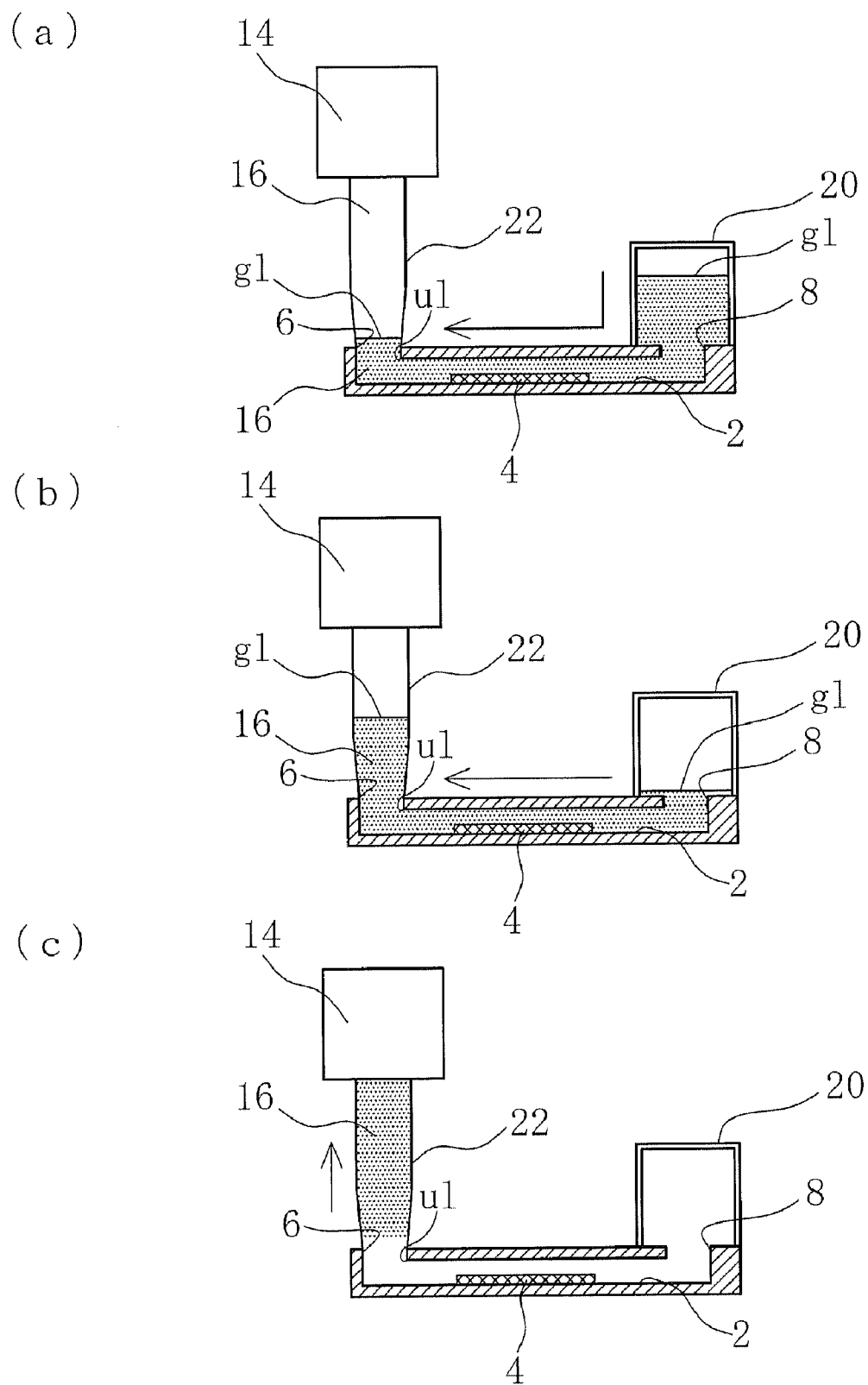

[Fig. 4]

(a)

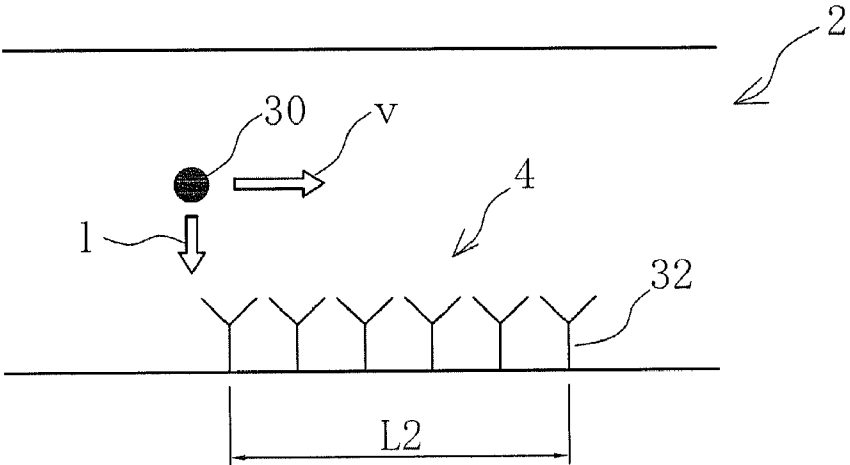

(b)

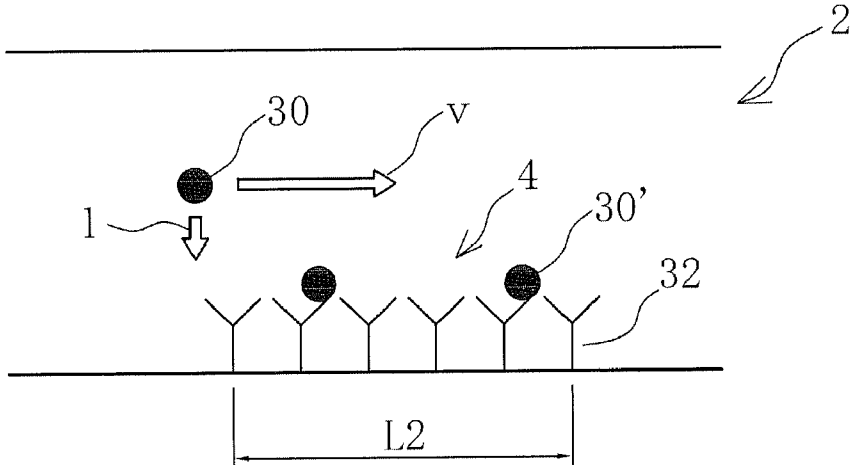

(c)

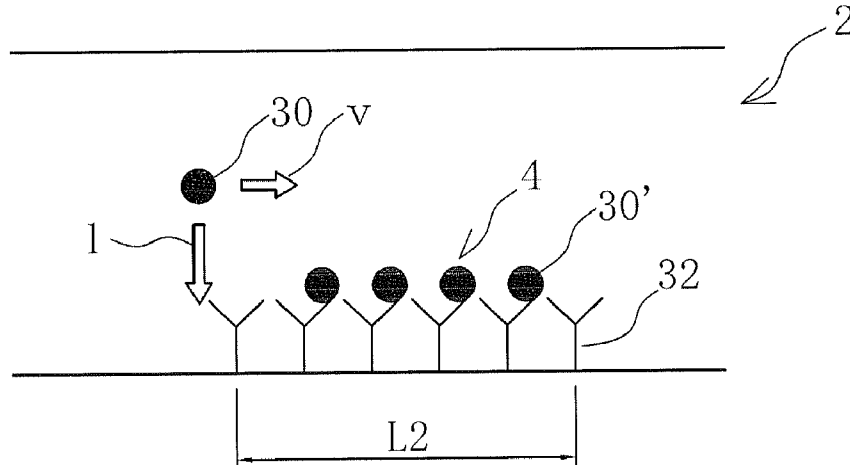

FIG. 5

Result of a simulation of the reaction amount
(width of a flow passage 2 mm, Height of a passage 50 μm)

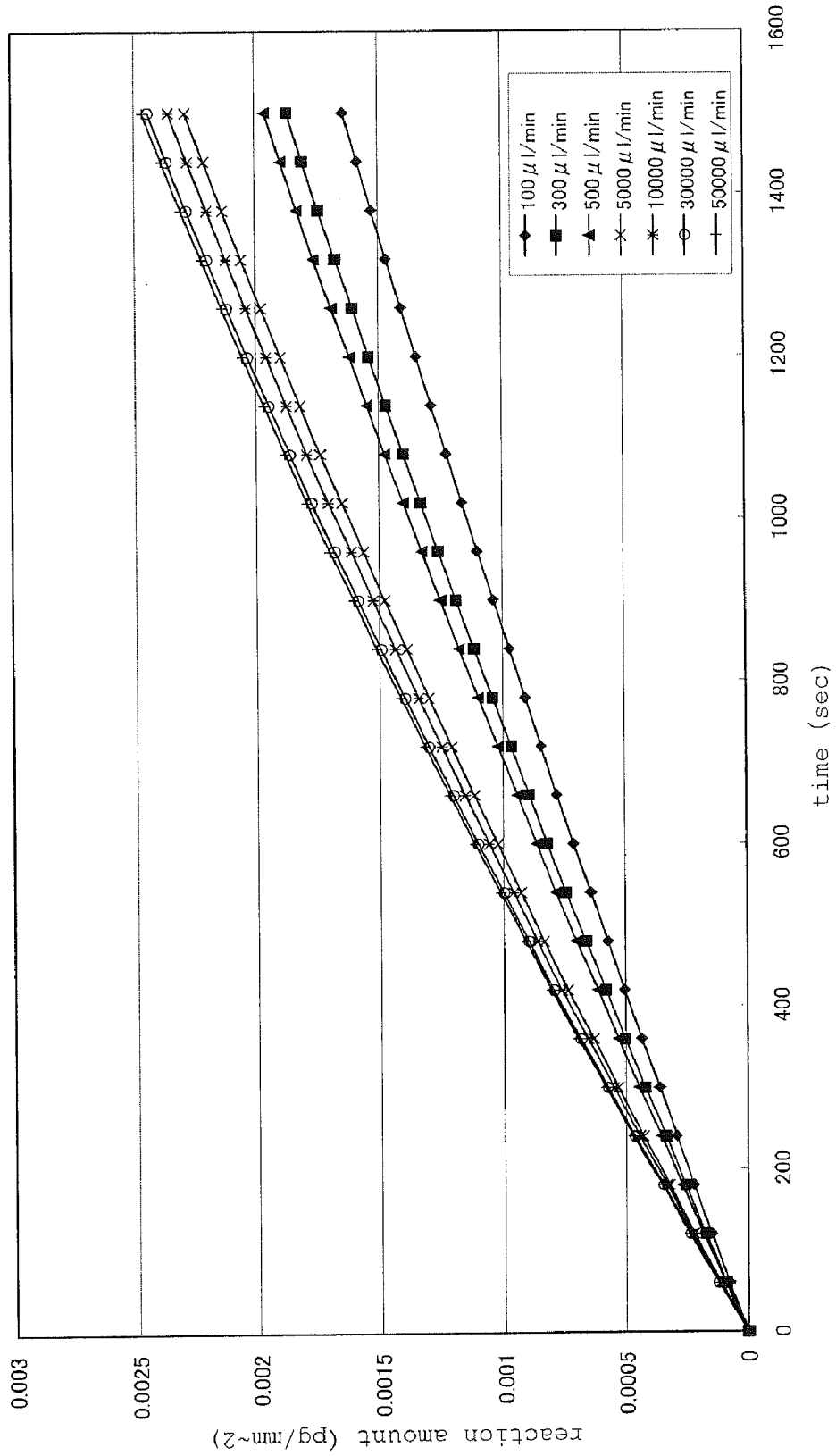

FIG. 6

Result of a simulation of the reaction amount
(width of a flow passage 2 mm, Height of a passage 50 μm)

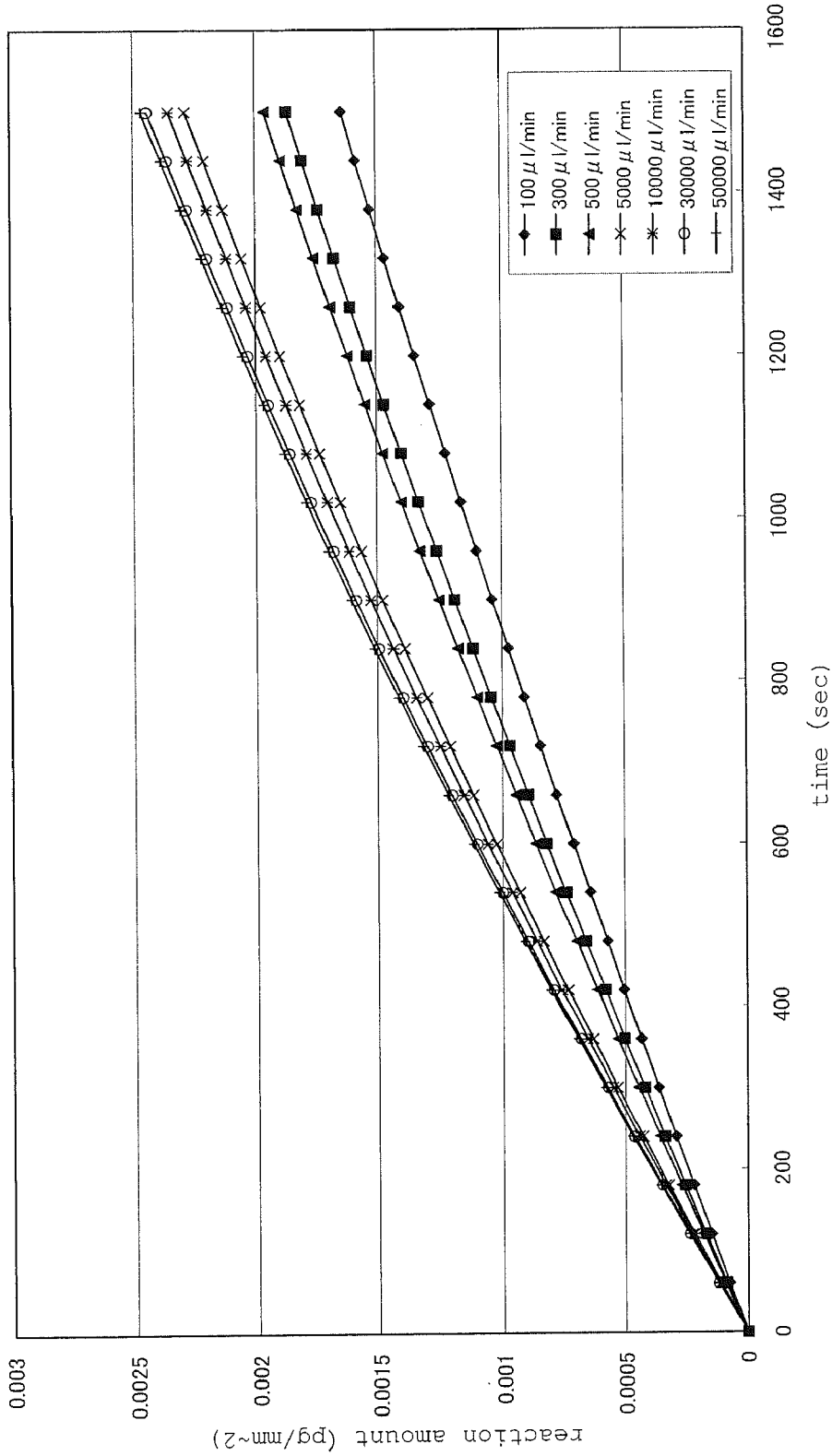
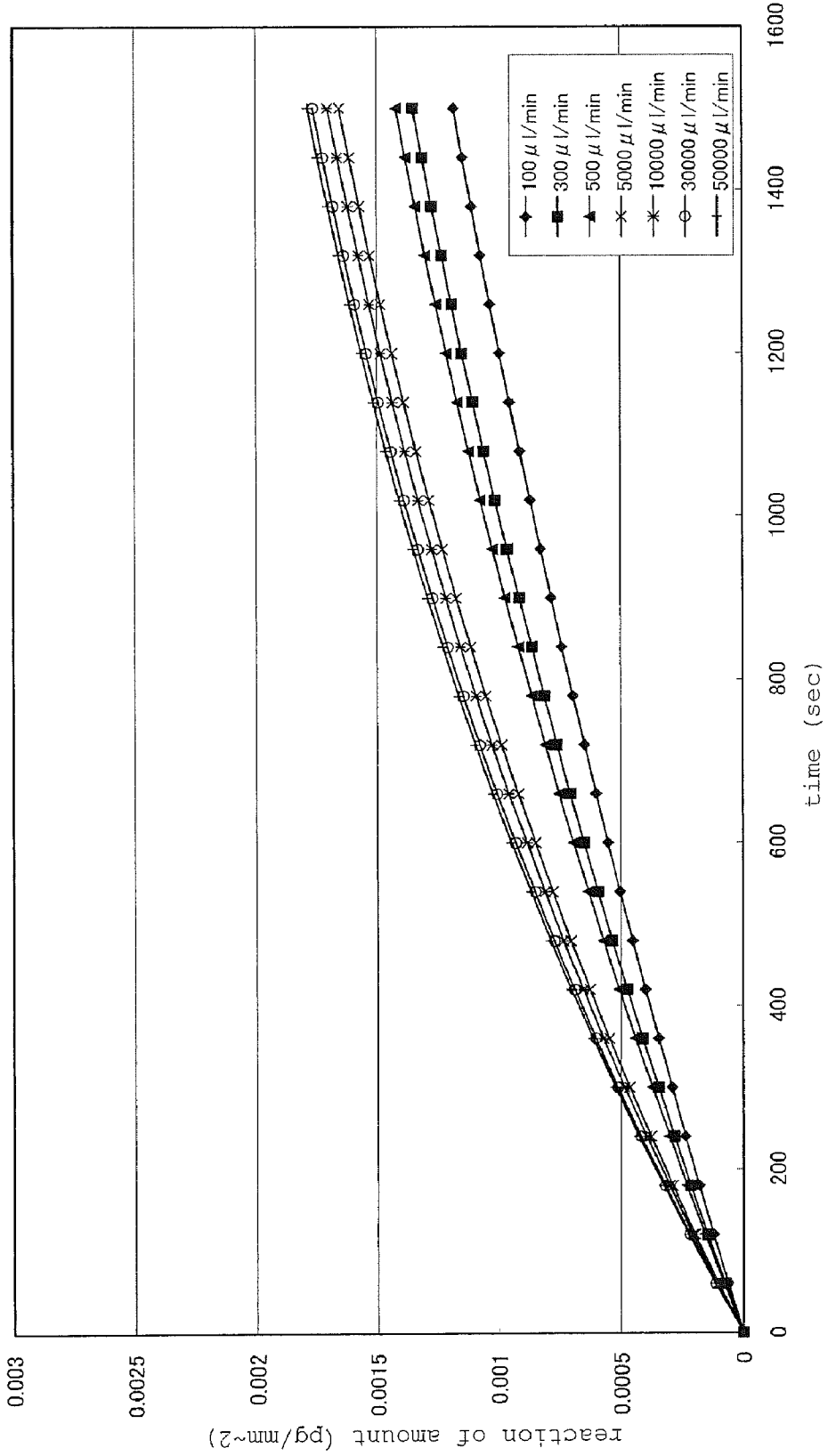

FIG. 7

Result of a simulation of the reaction amount [Embodiment 2]
(width of a flow passage 3 mm, Height of a flow passage 500 μm)



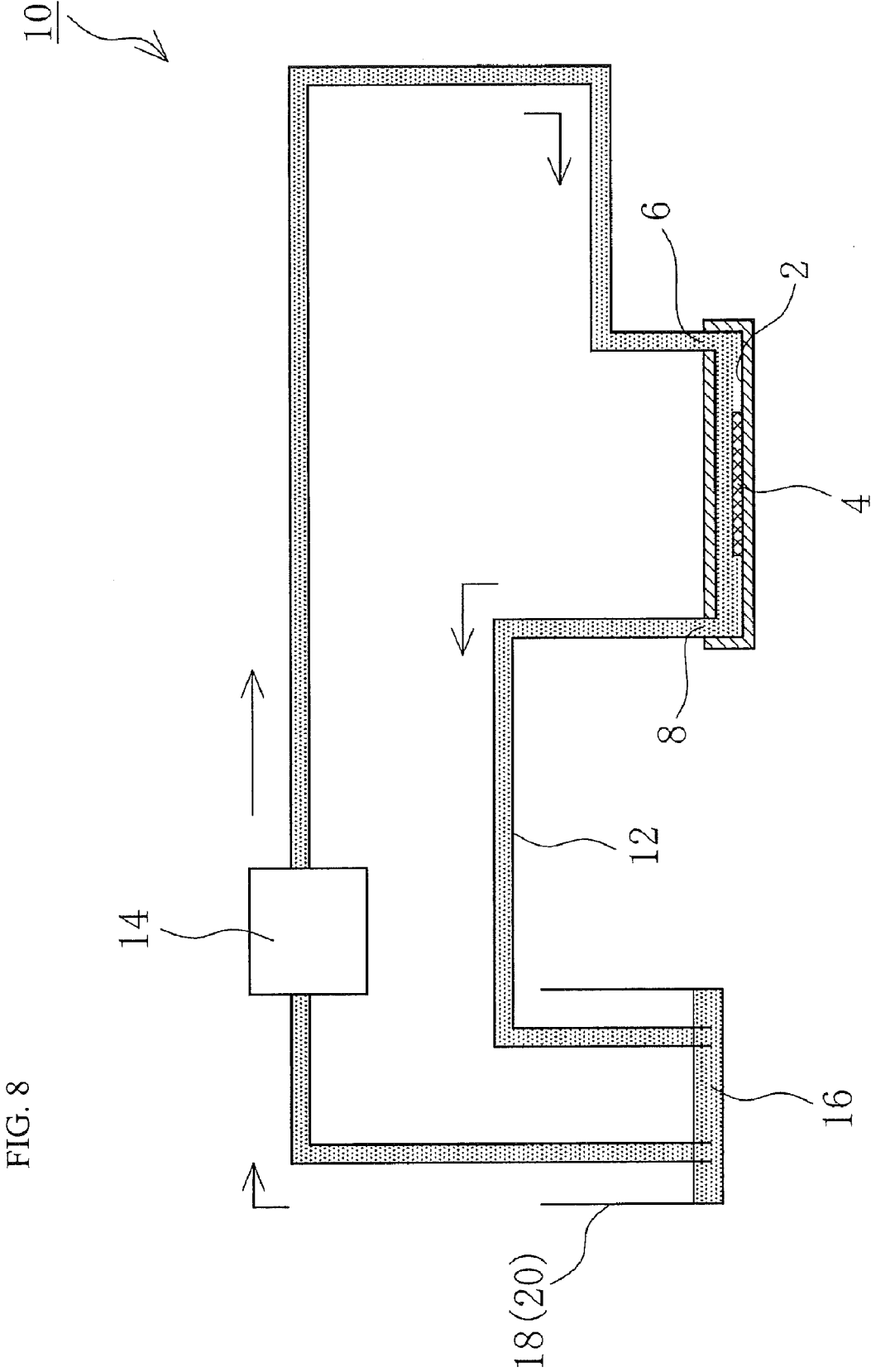

FIG. 8

FIG. 9

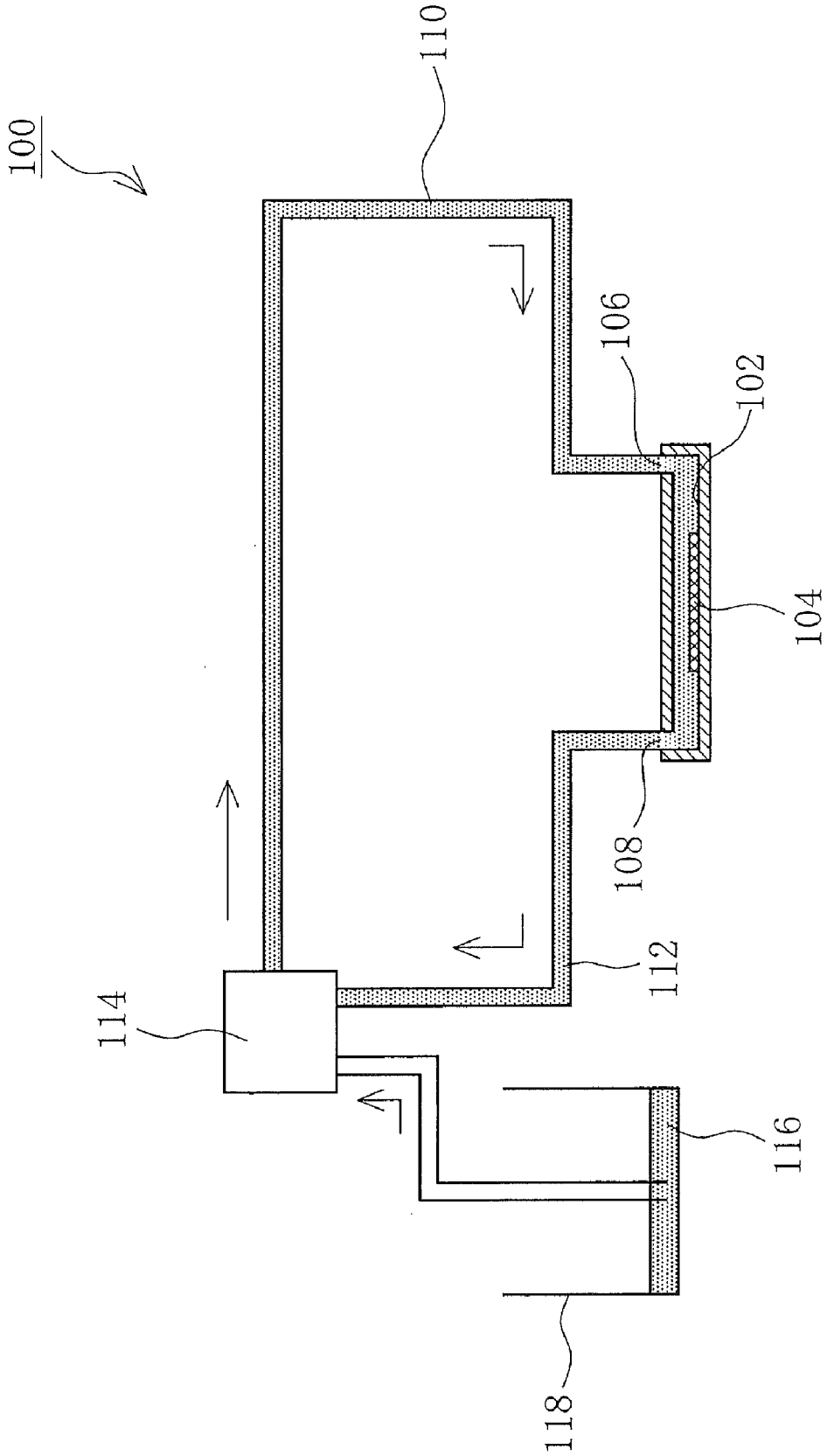
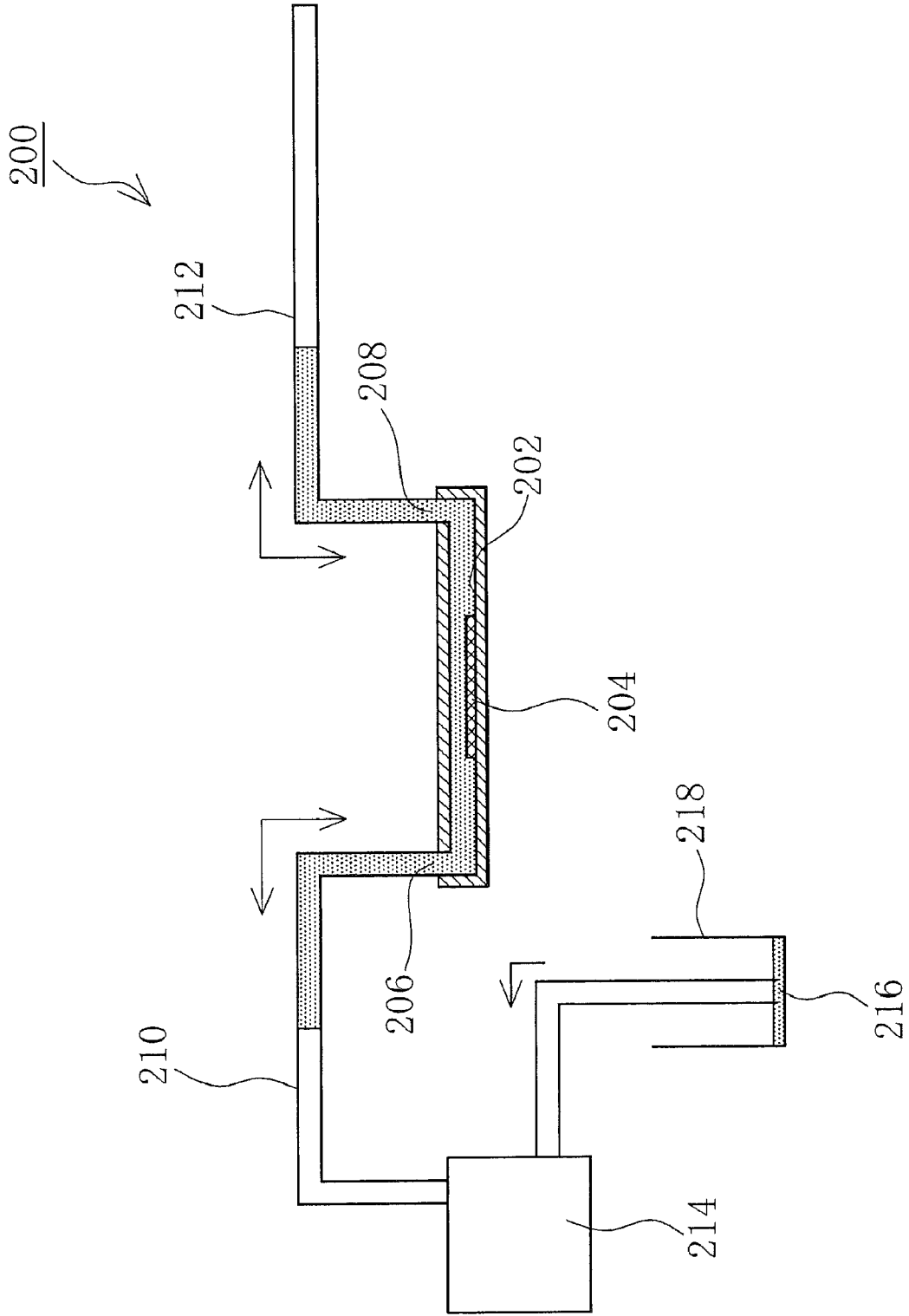

FIG. 10



MICROCHIP SOLUTION SENDING SYSTEM

BACKGROUND OF INVENTION

Technical Field

[0001] The present invention relates to a microchip solution sending system. More specifically, the present invention relates to a microchip solution sending system that is suitably utilized for an inspection and an analysis of a biological substance in which an antigen antibody reaction is used.

[0002] In the case in which a detection of an extremely fine substance is carried out, a wide variety of specimen material detection apparatus has been used for enabling an inspection of such an extremely fine substance by putting a physical phenomenon of a substance to practical use from the past.

[0003] As one of such specimen material detection apparatuses, there can be mentioned for instance a surface plasmon resonance apparatus (hereafter referred to as a SPR apparatus) in which a phenomenon for obtaining a high optical output by a resonance of an electron and a light in a minute region of a nanometer level or the like (a surface plasmon resonance (SPR: Surface Plasmon Resonance) phenomenon) is put to practical use and an extremely fine analyte in a biological body is detected for instance.

[0004] As one of such specimen material detection apparatuses, there also can be mentioned for instance a surface plasmon field enhanced fluorescence spectroscopic measurement apparatus (hereafter referred to as a SPFS apparatus) in which the analyte detection can be carried out with a higher degree of accuracy as compared with the SPR apparatus based on a principle of a surface plasmon excitation enhanced fluorescence spectroscopy (SPFS: Surface Plasmon-field enhanced Fluorescence Spectroscopy) for putting a surface plasmon resonance (SPR) phenomenon to practical use.

[0005] For the above described specimen material detection apparatus, a specimen material solution that contains an analyte (antigen) that is a detection target is prepared in advance, the specimen material solution is sent to a fine flow passage, and an analyte (antigen) is captured with an antibody that is fixed to a reaction field that is disposed in the fine flow passage. The specimen material detection apparatus is provided with a microchip solution sending system for sending a specimen material solution into a fine flow passage most commonly.

[0006] As such a microchip solution sending system, there can be mentioned for instance a system that is called a circulation type in which a specimen material solution is circulated and passes through a reaction field in a repetitive manner (see FIG. 9) and a system that is called a reciprocation type in which a specimen material solution is reciprocated and passes through a reaction field in a repetitive manner (see FIG. 10) in addition to a system that is called a one pass type in which a specimen material solution passes through a reaction field only one time.

[0007] For a microchip solution sending system 100 of a circulation type shown in FIG. 9, an inlet side flow passage 110 and an outlet side flow passage 112 are connected to an inlet hole 106 and an outlet hole 108 of a fine flow passage 102, respectively, and the inlet side flow passage 110 and the outlet side flow passage 112 are connected to a circulation solution sending pump 114.

[0008] The circulation solution sending pump 114 performs a suction of a specimen material solution 116 from a specimen material solution container 118 that holds the speci-

men material solution 116, circulates the specimen material solution 116 to the inlet side flow passage 110, the fine flow passage 102, and the outlet side flow passage 112 in this order, and makes the specimen material solution 116 pass through a reaction field 104 in a repetitive manner. By this configuration, an analyte of a desired amount can be captured at the reaction field 104 even if an amount of the specimen material solution 116 is small (see Patent Literature 1 and Patent Literature 2 for instance).

[0009] For a microchip solution sending system 200 of a reciprocation type shown in FIG. 10, an inlet side flow passage 210 and an outlet side flow passage 212 are disposed at an inlet hole 206 and an outlet hole 208 of a fine flow passage 202, respectively, and a reciprocation solution sending pump 214 is connected to the inlet side flow passage 210. Moreover, the reciprocation solution sending pump 214 is connected to a specimen material solution container 218 that holds the specimen material solution 216.

[0010] By operating the reciprocation solution sending pump 214, the specimen material solution 216 that has been sucked from the specimen material solution container 218 is sent to the inlet side flow passage 210, the fine flow passage 202, and the outlet side flow passage 212 in this order.

[0011] Moreover, the reciprocation solution sending pump 214 enables a reciprocating movement of the specimen material solution 216 in the directions from one side to the other side and from the other side to one side. By this configuration, the specimen material solution 216 is then sent to the outlet side flow passage 212, the fine flow passage 202, and the inlet side flow passage 210 in this order, and passes through a reaction field 204 in a repetitive manner, whereby an analyte of a desired amount can be captured at the reaction field 204 even if an amount of the specimen material solution 216 is small (see Patent Literature 3 and Patent Literature 4 for instance).

[0012] For the conventional microchip solution sending systems 100 and 200 above described, a flow passage cross section of the fine flow passages 102 and 202 is in a generally rectangular shape, a width of the flow passage is approximately in the range of 0.5 mm to 3 mm, and a height of the flow passage is approximately in the range of 50 μ m to 500 μ m. A rate of flow of a specimen material solution that is sent to the fine flow passage is approximately in the range of 1 μ l/min to 100 μ l/min, and 500 μ l/min or less even in the case in which an amount of a sent solution is large. As described above, the conventional microchip solution sending system is configured in such a manner that a solution is sent at a low rate region of flow of 500 μ l/min or less even in the case in which a rate of flow of a specimen material solution that is sent to the fine flow passage is large. This is because a velocity of flow of a specimen material solution is small and the specimen material solution passes through a reaction field in a slow pace in the case in which a rate of flow of a specimen material solution is small, whereby the reaction efficiency in the case in which the specimen material solution passes through a reaction field becomes higher.

PRIOR ART DOCUMENTS

Patent Literature

[Patent Literature 1]

[0013] Japanese Patent Application Laid-Open Publication No. 2004-163259

[Patent Literature 2]

[0014] Japanese Patent Application Laid-Open Publication No. 2006-242912

[Patent Literature 3]

[0015] Japanese Patent Application Laid-Open Publication No. 2005-134372

[Patent Literature 4]

[0016] Japanese Patent Application Laid-Open Publication No. 2006-90985

[0017] However, since it is not said that the reaction efficiency is sufficiently high for the conventional microchip solution sending system above described, it is desired that the reaction efficiency of the conventional microchip solution sending system is further improved.

[0018] Moreover, for the conventional microchip solution sending system above described, the dispersion between individual pieces occurs for a reaction amount of an analyte that is detected in some cases. In other words, even in the case in which two microchip solution sending systems of the same specification are used under the same conditions, the reaction amounts of the analyte that is detected are different from each other in some cases. The dispersion of a reaction amount between individual pieces indicates a detection accuracy of the microchip solution sending system, and it is desired that the detection accuracy of the conventional microchip solution sending system is further improved.

SUMMARY OF INVENTION

[0019] As a result of that the present applicant has examined the conditions under such a situation with all heart and soul, in the case in which a solution sending is carried out in a high flow rate region that has not been used for a microchip solution sending system that is called a circulation type or a reciprocation type, the reaction efficiency can be further improved, and the dispersion of a reaction amount between individual pieces of the analytes that are detected can be suppressed from occurring. The present applicant has found the above effects and completed the present invention.

[0020] The present invention was made in order to solve the above problems of the conventional art. A microchip solution sending system in accordance with the present invention is characterized by comprising: a flow passage that is provided with a reaction field to which an antibody that reacts with a specific antigen is fixed; and a solution sending pump that is configured to send a specimen material solution that includes the specific antigen, wherein a specimen material solution passes through a reaction field of the flow passage in a repetitive manner in the case in which the solution sending pump sends the specimen material solution, and a flow rate of the specimen material solution that is sent by the solution sending pump is in the range of 1,000 $\mu\text{l}/\text{min}$ to 50,000 $\mu\text{l}/\text{min}$.

BRIEF DESCRIPTION OF THE DRAWINGS

[0021] FIG. 1 is a schematic view for illustrating a microchip solution sending system in accordance with the present invention.

[0022] FIG. 2 is a schematic view for illustrating a flow of a specimen material solution for a microchip solution sending system in accordance with the present invention.

[0023] FIG. 3 is a schematic view for illustrating a flow of a specimen material solution for a microchip solution sending system in accordance with the present invention.

[0024] FIG. 4 is a schematic view for illustrating a relationship between a velocity of flow of a specimen material solution in a fine flow passage and the reaction efficiency of a reaction field.

[0025] FIG. 5 is a graph that indicates a result of a simulation of the reaction amount in the case in which a flow rate of a specimen material solution is changed for a microchip solution sending system in accordance with the present embodiment.

[0026] FIG. 6 is a graph that indicates a result of a simulation of the reaction amount in the case in which a flow rate of a specimen material solution is changed under the condition of the embodiment 1.

[0027] FIG. 7 is a graph that indicates a result of a simulation of the reaction amount in the case in which a flow rate of a specimen material solution is changed under the condition of the embodiment 2.

[0028] FIG. 8 is a schematic view showing a microchip solution sending system in accordance with another embodiment of the present invention.

[0029] FIG. 9 is a schematic view showing a conventional microchip solution sending system of a circulation type.

[0030] FIG. 10 is a schematic view showing a conventional microchip solution sending system of a reciprocation type.

DETAILED DESCRIPTION OF THE PREFERRED EMBODIMENT

[0031] Hereinbelow, an embodiment of the present invention is described.

[0032] A microchip solution sending system in accordance with the present invention is characterized by comprising: a flow passage that is provided with a reaction field to which an antibody that reacts with a specific antigen is fixed; and a solution sending pump that is configured to send a specimen material solution that includes the specific antigen, wherein a specimen material solution passes through a reaction field of the flow passage in a repetitive manner in the case in which the solution sending pump sends the specimen material solution, and a flow rate of the specimen material solution that is sent by the solution sending pump is in the range of 1,000 $\mu\text{l}/\text{min}$ to 50,000 $\mu\text{l}/\text{min}$.

[0033] By the above configuration, a flow rate of a specimen material solution that is sent by the solution sending pump can be in the range of a high flow rate region of 1,000 $\mu\text{l}/\text{min}$ to 50,000 $\mu\text{l}/\text{min}$, whereby the reaction efficiency can be improved.

[0034] Moreover, the dispersion of a reaction amount between individual pieces of the analytes (antigens) that are captured with an antibody can be suppressed from occurring for the microchip solution sending systems of the same specification, whereby the detection accuracy can be improved.

[0035] The microchip solution sending system in accordance with the present invention is characterized by further comprising a mixing part that is connected to the flow passage in which the specimen material solution that has passed through the reaction field of the flow passage is stored temporarily and the specimen material solution that has been stored is stirred.

[0036] By comprising the above mixing part, the specimen material solution of a high flow rate region of 1,000 $\mu\text{l}/\text{min}$ to 50,000 $\mu\text{l}/\text{min}$ can be sent in a repetitive manner without

reducing the reaction efficiency for the microchip solution sending system of so-called a circulation type and the microchip solution sending system of a reciprocation type in which the specimen material solution passes through the reaction field of the flow passage in a repetitive manner.

[0037] The microchip solution sending system in accordance with the present invention is characterized in that a cross section of the flow passage is in a rectangular shape, and a width of the flow passage is in the range of 0.5 mm to 3 mm and a height of the flow passage is in the range of 50 μm to 500 μm preferably.

[0038] It is not necessarily that the rectangular shape of a cross section of the flow passage is a perfect rectangular shape. The rectangular shape can be a shape that is considered as a substantive rectangular shape as a whole of a flow passage cross section. Consequently, the above rectangular shape can also include a tapered shape or an R shape of a corner part and a slight concave-convex shape of a whole or a part of a side for instance.

[0039] By the above configuration, in the case in which a flow rate of the specimen material solution that is sent by the solution sending pump is in the range of a high flow rate region of 1,000 $\mu\text{l}/\text{min}$ to 50,000 $\mu\text{l}/\text{min}$, the reaction efficiency can be improved and the detection accuracy can be improved, whereby the features of the microchip solution sending system in accordance with the present invention can be displayed more preferably.

[0040] Moreover, in the case in which a flow rate of the specimen material solution that is sent by the solution sending pump is in the range of 5,000 $\mu\text{l}/\text{min}$ to 50,000 $\mu\text{l}/\text{min}$, the effects of the present invention can be displayed more preferably.

[0041] A specimen material detection apparatus in accordance with the present invention is characterized by comprising any one of the microchip solution sending systems above described.

[0042] By the above configuration, the reaction efficiency can be improved as compared with a specimen material detection apparatus that is provided with a conventional microchip solution sending system, and the specimen material detection apparatus can be provided with a high accuracy with a small dispersion between individual pieces.

[0043] The specimen material detection apparatus in accordance with the present invention is characterized in that the specimen material detection apparatus is a surface plasmon resonance apparatus (a SPR apparatus) or a surface plasmon field enhanced fluorescence spectroscopic measurement apparatus (a SPFS apparatus).

[0044] In the case in which the specimen material detection apparatus is a surface plasmon resonance apparatus (a SPR apparatus) or a surface plasmon field enhanced fluorescence spectroscopic measurement apparatus (a SPFS apparatus) as described above, the specimen material detection apparatus is suitable as detection apparatus of an extremely minute analyte in particular. Moreover, the reaction efficiency can be improved as compared with a SPR apparatus or a SPFS apparatus that is provided with a conventional microchip solution

sending system, and the SPR apparatus or the SPFS apparatus can be provided with a high accuracy with a small dispersion between individual pieces.

[0045] In accordance with the present invention, for a microchip solution sending system that is called a circulation type or a reciprocation type in which a specimen material solution passes through a reaction field of a flow passage in a repetitive manner, a flow rate of the specimen material solution that is sent by the solution sending pump is in the range of a high flow rate region of 1,000 $\mu\text{l}/\text{min}$ to 50,000 $\mu\text{l}/\text{min}$, whereby the reaction efficiency can be improved, and thereby providing a microchip solution sending system that is provided with a high accuracy with a small dispersion of a reaction amount between individual pieces of the analytes that are detected and a high-accuracy specimen material detection apparatus that is provided with the microchip solution sending system.

[0046] An embodiment (example) of the present invention will be described below in detail with reference to the drawings. While the preferred embodiments in accordance with the present invention will be described in the following, the present invention is not restricted to the embodiments.

<Microchip Solution Sending System 10>

[0047] FIG. 1 is a schematic view for illustrating a microchip solution sending system 10 in accordance with the present invention. FIG. 1(a) is a cross-sectional view showing the microchip solution sending system 10. FIG. 1(b) is an A-A view of the microchip solution sending system 10 in accordance with the present invention taken along the line A-A viewed from the direction of the arrows A of FIG. 1(a). FIG. 1(c) is a B-B view of the microchip solution sending system 10 in accordance with the present invention taken along the line B-B viewed from the direction of the arrows B of FIG. 1(b).

[0048] As shown in FIG. 1(a), the microchip solution sending system 10 in accordance with the present invention is provided with a fine flow passage 2 and a solution sending pump 14 that is configured to send a specimen material solution 16. Moreover, a reaction field 4 to which an antibody of a predetermined amount that reacts with a specific antigen is fixed is disposed on the bottom surface in the fine flow passage 2. In the case in which the solution sending pump 14 sends the specimen material solution 16 that includes a specific antigen (analyte), the specimen material solution 16 passes through the reaction field 4 of the fine flow passage 2 in a repetitive manner.

[0049] For the microchip solution sending system 10 in accordance with the present invention, although a shape of a cross section of the fine flow passage 2 is not restricted in particular, the cross section of the fine flow passage 2 is in a generally rectangular shape in the present embodiment. In the case in which the cross section of the fine flow passage 2 is in a generally rectangular shape, it is preferable that a width D of the flow passage of the fine flow passage 2 is in the range of 0.5 mm to 3 mm and a height H of the flow passage of the fine flow passage 2 is in the range of 50 μm to 500 μm . In the present embodiment, D=2 mm and H=50 μm .

[0050] Moreover, a length L1 of the flow passage of the fine flow passage 2 is in the range of 2 mm to 30 mm preferably, and in the range of 2 mm to 20 mm more preferably. In the present embodiment, L1=14 mm.

[0051] A forming range of the reaction field 4 is appropriately configured in consideration of a shape of the fine flow passage 2 and an amount of an analyte that is supplied in such a manner that an analyte of a desired amount can be captured in an efficient manner. In the present embodiment, the reaction field 4 is formed along the whole width of the bottom surface, and a length L2 in the direction of the flow passage is 2 mm.

[0052] As shown in FIGS. 1(a) and 1(b), an inlet hole 6 that is an inlet for flowing the specimen material solution 16 into the fine flow passage 2 is formed on one end side in the direction of the flow passage of the fine flow passage 2, and an outlet hole 8 that is an outlet of the specimen material solution 16 that has been flown from the inlet hole 6 is formed on the other end side in the direction of the flow passage of the fine flow passage 2. For the microchip solution sending system 10 in accordance with the present invention, it is preferable that the diameter of the inlet hole 6 and the outlet hole 8 is in the range of $\phi 0.5$ mm to $\phi 3$ mm, which is almost equivalent to the width D of the flow passage of the fine flow passage 2. In the present embodiment, the diameter is $\phi 2$ mm.

[0053] As shown in FIG. 1(a), a pipette 22 that holds the specimen material solution 16 is connected to the upper face side of the inlet hole 6. An end 22a of the pipette 22 is in a cross sectional shape that is almost equivalent to that of the inlet hole 6, and the pipette 22 is configured in a detachable manner from the inlet hole 6 of the fine flow passage 2. A diameter of a base end part 22b of the pipette 22 is larger than that of the end 22a. In the present embodiment, the specimen material solution 16 of 100 μ l is held in the pipette 22.

[0054] The solution sending pump 14 is attached to the upper part of the pipette 22. The solution sending pump 14 communicates with a control part 15. In accordance with the command from the control part 15, the solution sending pump 14 discharges the specimen material solution 16 that has been held in the pipette 22 to the fine flow passage 2, and performs a suction of the specimen material solution 16 that has been stored in the fine flow passage 2 or in a mixing part 20 described later into the pipette 22. Moreover, the solution sending pump 14 can send the specimen material solution 16 in the range of a high flow rate region of 1,000 p. 1/min to 50,000 μ l/min.

[0055] As shown in FIG. 1(a), the mixing part 20 is connected to the upper face side of the outlet hole 8. A cross sectional shape of the mixing part 20 is a rectangular shape or a circular shape that is larger than a cross sectional shape of the outlet hole 8, and one side of the cross sectional shape of the mixing part 20 is in the range of 5 mm to 12 mm for instance. In the present embodiment, the mixing part 20 is in a generally square shape of which one side is 8 mm.

[0056] A flowing operation of the microchip solution sending system 10 in accordance with the present embodiment will be described with reference to FIGS. 2 and 3. FIGS. 2(a) to 2(c) and 3(a) to 3(c) are schematic views for illustrating a

flow of the specimen material solution 16 for the microchip solution sending system 10 in accordance with the present invention. The arrows of FIGS. 2 and 3 indicate a solution sending direction of the specimen material solution 16. A sign gl indicates an interfacial boundary surface between the specimen material solution 16 and an air, that is, an air-liquid interface, and a sign ul indicates a height of the upper face of the flow passage of the fine flow passage 2.

[0057] FIG. 2(a) shows the state in which the pipette 22 that holds the specimen material solution 16 is mounted to the inlet hole 6 of the fine flow passage 2 and the solution sending pump 14 is attached to the pipette 22.

[0058] In the case in which the solution sending pump 14 is driven and the specimen material solution 16 that has been held in the pipette 22 is discharged in the state shown in FIG. 2(a), the specimen material solution 16 is flown into the fine flow passage 2 via the inlet hole 6 and a part of the specimen material solution 16 passes over the reaction field 4 as shown in FIG. 2(b).

[0059] In the case in which the solution sending pump 14 further discharges the specimen material solution 16 that has been held in the pipette 22 from this state, the most of the specimen material solution 16 in the pipette 22 is flown into the fine flow passage 2 via the inlet hole 6 and an air-liquid interface gl in the pipette 22 is lowered close to the height ul of the upper face of the flow passage of the fine flow passage 2 as shown in FIG. 2(c). In addition, the specimen material solution 16 that has passed over the reaction field 4 is flown into the mixing part 20 via the outlet hole 8, and an air-liquid interface gl in the mixing part 20 moves upward.

[0060] The solution sending pump 14 is then driven in order to suck the specimen material solution 16 in this state. By this operation, a solution sending direction of the specimen material solution 16 is then reversed as shown in FIG. 3(a). The specimen material solution 16 in the mixing part 20 is then flown into the fine flow passage 2 via the outlet hole 8, passes over the reaction field 4 again, and is flown into the pipette 22 via the inlet hole 6. An air-liquid interface gl in the pipette 22 moves upward, and an air-liquid interface gl in the mixing part 20 is lowered close to the height ul of the upper face of the flow passage of the fine flow passage 2 as shown in FIG. 3(b).

[0061] The solution sending pump 14 is then driven in order to discharge the specimen material solution 16 in the state shown in FIG. 3(b). By this operation, a solution sending direction of the specimen material solution 16 is then reversed again. The specimen material solution 16 in the pipette 22 is then flown into the fine flow passage 2 via the inlet hole 6, passes over the reaction field 4 again, and is flown into the mixing part 20 via the outlet hole 8 in the state shown in FIG. 2(c).

[0062] In the case in which the specimen material solution 16 is recovered, after the solution sending pump 14 performs a suction of the specimen material solution 16 to the state shown in FIG. 3(c), the pipette 22 that holds the specimen material solution 16 can be detached.

[0063] For the microchip solution sending system 10 in accordance with the present embodiment as described above, the states of FIG. 2(c), FIG. 3(a), FIG. 3(b), and FIG. 2(c) are

transferred in a repetitive manner by operating the discharge and the suction using the solution sending pump **14** in a repetitive manner, whereby the specimen material solution **16** passes over the reaction field **4** in the fine flow passage **2** in a repetitive manner.

[0064] In this case, it is preferable that the switching of a driving state of the solution sending pump **14** is carried out in such a manner that an air-liquid interface **gl** in the pipette **22** and in the mixing part **20** is not lower than the height **ul** of the upper face of the flow passage of the fine flow passage **2**. By this configuration, an air is not mixed into the fine flow passage **2**, whereby a failure that may occur due to a mixture of an air into the fine flow passage **2** can be prevented, for instance, a deterioration of a solution sending ability due to an increase in a solution sending resistance and a reduction of the reaction efficiency due to a mixed air that covers the reaction field **4** can be prevented.

[0065] It is preferable that the microchip solution sending system **10** in accordance with the present invention is configured as described in the following in order to automatically switch a driving state of the solution sending pump **14**.

[0066] That is, it is preferable that a sensor that is configured to measure an air-liquid interface **gl** is disposed in at least one of the pipette **22** and the mixing part **20** in order to automatically switch a driving state of the solution sending pump **14**. In the case in which an air-liquid interface **gl** is equal to or less than the predetermined level, a signal is sent from the sensor to the control part **15**, and the control part **15** issues the command to the solution sending pump **14** to switch a driving state.

[0067] Moreover, it also can be set that a driving state is automatically switched in the case in which the solution sending pump **14** sends the specimen material solution **16** of a predetermined amount that has been specified in advance, whereby a driving state of the solution sending pump **14** can be automatically switched. For instance, a difference that is obtained by subtracting a stored amount of the specimen material solution **16** in the pipette **22** in the state shown in FIG. 3(a) from a stored amount of the specimen material solution **16** in the pipette **22** in the state shown in FIG. 3(b) is set to the control part **15** in advance as an amount of a solution to be sent by the solution sending pump **14**. In the case in which an amount of the specimen material solution **16** that is discharged (or sucked) by the solution sending pump **14** reaches the above amount, a driving state of the solution sending pump **14** can be automatically switched.

[0068] In the next place, an effect of an installation of the mixing part **20** will be described in the following.

[0069] The specimen material solution is flown in the fine flow passage **2** in a laminar flow state, that is, a state in which the streamlines of fluids are generally parallel to each other on a constant basis for the microchip solution sending system. Consequently, in the case in which the specimen material solution **216** is reciprocated simply like the conventional microchip solution sending system **200** shown in FIG. 10 for instance, the specimen material solution **216** of the same layer comes into contact with the reaction field **204** on a constant

basis. As a result, only a part of the specimen material solution **216** contributes to a reaction on the reaction field **204**.

[0070] On the other hand, the microchip solution sending system **10** in accordance with the present embodiment is provided with the mixing part **20** with a cross sectional shape larger than a cross section of the fine flow passage **2**. Consequently, in the case in which the specimen material solution **16** is flown into the mixing part **20**, the specimen material solution **16** that is stored in the mixing part **20** is stirred due to a turbulence of a flow of the specimen material solution **16** that has been flown in a laminar flow state. Accordingly, even in the case in which the specimen material solution **16** passes on the reaction field **4** in a repetitive manner, only the same layer does not come into contact with the reaction field **4**, and most of the specimen material solution **16** contributes to a reaction on the reaction field **4**. Moreover, the specimen material solution **16** that is stored in the pipette **22** is also stirred similarly.

[0071] Consequently, since the mixing part **20** above described is disposed for the microchip solution sending system **10** in accordance with the present invention in which the specimen material solution **16** passes on the reaction field **4** in the fine flow passage **2** in a repetitive manner, the reaction efficiency can be prevented from being reduced and the specimen material solution **16** of a high flow rate region in the range of 1,000 $\mu\text{l}/\text{min}$ to 50,000 $\mu\text{l}/\text{min}$ can be sent in a repetitive manner.

<Effect of Sending the Specimen Material Solution **16** in a High Flow Rate Region>

[0072] In the next place, the following describes an effect of sending the specimen material solution **16** in a high flow rate region in the range of 1,000 $\mu\text{l}/\text{min}$ to 50,000 $\mu\text{l}/\text{min}$ for the microchip solution sending system **10** described above.

[0073] A rate of flow that is described here means an amount of a fluid that is flown in a unit time and is indicated by $\mu\text{l}/\text{min}$. Moreover, a velocity of flow is obtained by dividing a rate of flow by a cross sectional area of a flow passage and means a distance in which a fluid moves in a unit time. The velocity of flow is indicated by mm/min or mm/sec .

[0074] FIG. 4 is a schematic view for illustrating a relationship between a velocity v of flow of the specimen material solution **16** in the fine flow passage **2** and the reaction efficiency of the reaction field **4**. A sign v in FIG. 4 indicates a velocity of flow of the specimen material solution **16** that is flown in the fine flow passage **2**, and a sign **1** indicates a diffusion distance of an analyte (antigen) **30**. A size of an arrow of the velocity v of flow and the diffusion distance **1** indicates a degree of a velocity of flow and a degree of a diffusion distance, respectively.

[0075] Here, a time t that is required for the analyte **30** shown in FIG. 4(a) to pass on the reaction field **4** is represented by the expression (1).

[Expression 1]

$$t=L2/v \quad (1)$$

[0076] Here, $L2$ indicates a length of the reaction field **4**, and v indicates a rate of flow of the specimen material solution **16**.

[0077] Moreover, the diffusion distance **1** in which the analyte **30** shown in FIG. 4(a) moves in the bottom surface

direction when passing on the reaction field **4** is represented by the expression (2).

[Expression 2]

$$l = \sqrt{v \times t \times D} \quad (2)$$

[0078] Here, the time t is required for the analyte **30** to pass on the reaction field **4** and is a time that is calculated by the expression (1), and D is a diffusion constant.

[0079] As clarified by the expressions (1) and (2), as the velocity v of flow of the specimen material solution **16** is higher, the time t that is required for the analyte **30** to pass on the reaction field **4** is shorter, whereby the diffusion distance **1** is smaller. On the other hand, as the velocity v of flow of the specimen material solution **16** is lower, the time t that is required for the analyte **30** to pass on the reaction field **4** is longer, whereby the diffusion distance **1** is larger.

[0080] As the diffusion distance **1** of the analyte **30** is smaller, the number of the analytes **30** that are captured with an antibody **32** is less as shown in FIG. 4(b). On the other hand, as the diffusion distance **1** of the analyte **30** is larger, the number of the analytes **30** that are captured with an antibody **32** is larger as shown in FIG. 4(c).

[0081] As described above, as the velocity v of flow of the specimen material solution **16** is lower, the diffusion distance **1** of the analyte **30** is larger and the number of the analytes **30** that are captured with an antibody **32** is larger. Consequently, for the conventional microchip solution sending system, it is a technical common knowledge that the specimen material solution is sent in the range of a low rate region of flow of 1 $\mu\text{l}/\text{min}$ to 500 $\mu\text{l}/\text{min}$ for instance in such a manner that a rate of flow of the specimen material solution is lower even for a circulation type and a reciprocation type as well as a one pass type.

reaction time is constant. However, the effect can be obtained only for the microchip solution sending system in which the specimen material solution **16** passes on the reaction field **4** in a repetitive manner like the present invention. For the conventional microchip solution sending system of a one pass type, in the case in which the velocity of flow of the specimen material solution is higher, the time t that is required for the analyte **30** to pass on the reaction field **4** is shorter, whereby the reaction efficiency is reduced.

[0084] FIG. 5 and Table 1 indicate a result of a simulation of the reaction amount in a unit area in the case in which a flow rate of the specimen material solution **16** is in a low flow rate region of 100 $\mu\text{l}/\text{min}$, 300 $\mu\text{l}/\text{min}$, and 500 $\mu\text{l}/\text{min}$ (a comparative example) and is in a high flow rate region of 1,000 $\mu\text{l}/\text{min}$, 5,000 $\mu\text{l}/\text{min}$, 10,000 $\mu\text{l}/\text{min}$, 30,000 $\mu\text{l}/\text{min}$, and 50,000 $\mu\text{l}/\text{min}$ (the present embodiment) for the microchip solution sending system **10** in accordance with the present embodiment described above. A vertical axis of FIG. 5 represents a reaction amount in a unit area of the reaction field **4**, and a horizontal axis represents a measuring time. The conditions of an effective antibody density of the reaction field **4** and an amount of an antibody in the specimen material solution **16** in the case of the present embodiment are set to be equivalent to those in the case of the comparative example.

(Conditions)

[0085] Measuring time: 1500 sec

Width of a flow passage: 2 mm

Height of a flow passage: 50 μm

Shape of a reaction field: 2 mm \times 2 mm

Amount of a specimen material solution: 100 μl

TABLE 1

Flow rate ($\mu\text{l}/\text{min}$)	Amount of a specimen material solution (μl)	Effective antibody density (mol/cm^2)	Amount of an antigen (pg)	Number of passing (times/min)	Reaction amount in a unit area (pg/mm^2)	Note
100	100	6.70×10^{-12}	0.0175	1	0.00136	Comparative example
300				3	0.00156	
500				5	0.00164	
1,000				10	0.00187	Embodiment
5,000				50	0.00192	
10,000				100	0.00198	
30,000				300	0.00205	
50,000				500	0.00208	

[0082] However, for the microchip solution sending system **10** in accordance with the present embodiment as described above in which the specimen material solution **16** passes on the reaction field **4** in a repetitive manner, sending the specimen material solution **16** in the range of a low rate region of flow dose not always result in an improvement of the reaction efficiency. It has been found that the reaction efficiency can be improved in the case in which the specimen material solution **16** is sent in the range of a high rate region of flow.

[0083] This means that an effect of increasing a flow rate in a unit time and increasing the number of passing on the reaction field contributes to an improvement of the reaction efficiency rather than increasing the diffusion distance **1** under the condition in which a measuring time, that is, a

[0086] Table 2 indicates a result of an actual measurement of the fluorescence intensity in the case in which a flow rate of the specimen material solution **16** is in a low flow rate region of 100 $\mu\text{l}/\text{min}$, 300 $\mu\text{l}/\text{min}$, and 500 $\mu\text{l}/\text{min}$ (a comparative example) and is in a high flow rate region of 1,000 $\mu\text{l}/\text{min}$, 5,000 $\mu\text{l}/\text{min}$, 10,000 $\mu\text{l}/\text{min}$, 30,000 $\mu\text{l}/\text{min}$, and 50,000 $\mu\text{l}/\text{min}$ (the present embodiment) for the SPFS apparatus that is provided with the microchip solution sending system **10** in accordance with the present embodiment described above.

[0087] For the SPFS apparatus, as the number of the analytes **30** that have been captured is larger, that is, as a reaction amount in a unit area is larger, the higher fluorescence intensity is measured.

TABLE 2

Flow rate ($\mu\text{l}/\text{min}$)	Amount of a specimen material solution (μl)	Effective antibody density (mol/cm^2)	Amount of an antigen (pg)	Number of passing (times/min)	Fluorescence intensity	Note
100	100	6.70×10^{-12}	0.0175	1	24,800	Comparative example
300				3	28,500	
500				5	30,000	
1,000				10	34,100	Embodiment
5,000				50	35,100	
10,000				100	36,200	
30,000				300	37,600	
50,000				500	38,100	

[0088] As clarified by FIG. 5 and Table 1, at the point of time when a measuring time (1500 sec) elapses, as a rate of flow is higher, a reaction amount in a unit area is larger. A tendency of the simulation result can also be confirmed by a result of an actual measurement of the fluorescence intensity shown in Table 2.

[0089] This means that the reaction efficiency can be improved in the case in which a velocity of flow is made to be higher and the number of passing of the specimen material solution 16 on the reaction field 4 is made to be increased rather than the case in which a velocity of flow is made to be lower for the microchip solution sending system 10 in accordance with the present invention in which the specimen material solution 16 passes on the reaction field 4 in a repetitive manner.

[0090] As clarified by FIG. 5 and Table 1, a variation of a reaction amount that is associated with a variation of a rate of flow is smaller in the case of a high flow rate region (the present embodiment) as compared with the case of a low flow rate region (a comparative example). A tendency of the simulation result can also be confirmed by a result of an actual measurement of the fluorescence intensity shown in Table 2.

[0091] For the microchip solution sending system 10 in accordance with the present invention, a rate of flow of the specimen material solution 16 that is sent depends on an ability of the solution sending pump 14. The solution sending pump 14 is configured in such a manner that the specimen material solution 16 is discharged or sucked at a predetermined pressure, and is not configured in such a manner that a predetermined rate of flow is discharged or sucked directly. Consequently, even in the case in which the specimen material solution 16 is sent under the same conditions for two microchip solution sending systems 10 of the same specification, the rates of flow of the specimen material solutions 16 that are sent by the solution sending pump 14 as a practical matter are slightly different from each other due to an influence of a dimensional tolerance of a shape of the fine flow passage 2.

[0092] As described above, a variation of a reaction amount that is associated with a variation of a rate of flow is smaller in the case of a high flow rate region. This means that the dispersion of a reaction amount between individual pieces due to an influence of the dispersion of a width of a flow passage, a height of a flow passage, and a rate of flow of the microchip solution sending system 10 can be reduced, that is, a detection accuracy of the microchip solution sending sys-

tem 10 can be improved preferably in the case in which the specimen material solution 16 is sent in a high flow rate region.

[0093] For the present invention, a variation of a reaction amount that is associated with a variation of a rate of flow is smaller in the case in which the specimen material solution 16 is sent in a high flow rate region as described above. It is inferable that this is because a reaction of the analyte 30 with an antibody 32 becomes in the state close to a rate determining reaction in the state of a high flow rate region as compared with the state of a low flow rate region.

[0094] In other words, in order to improve the reaction efficiency of the analyte 30 with an antibody 32, it is thought that a reaction condition is increased (that is, an amount of an antibody 32 that is fixed to the reaction field 4 is increased) in addition to that a diffusion condition is increased (that is, the velocity v of flow of the specimen material solution 16 is lowered and the diffusion distance 1 is enlarged) and a supply condition is increased (that is, a rate of flow of the specimen material solution 16 is increased and an amount of the analyte 30 that is supplied to the reaction field 4 is increased). In the state in which a diffusion condition and a supply condition are increased for a certain amount of an antibody and the diffusion condition and the supply condition are satisfied sufficiently, the reaction efficiency is not further improved even if the diffusion condition and the supply condition are further increased. In other words, the reaction efficiency becomes in the state of a rate determining reaction that is controlled by the reaction condition mainly.

[0095] In the state of such a rate determining reaction, the reaction efficiency is not further improved even if of a rate of flow of the specimen material solution 16 is increased. For the present invention, a variation of a reaction amount that is associated with a variation of a rate of flow is smaller in the case in which the specimen material solution 16 is sent in a high flow rate region as described above. It is thought that this is because a reaction becomes in the state close to a rate determining reaction in the case in which a rate of flow of the specimen material solution 16 is in the range of a high flow rate region of 1,000 $\mu\text{l}/\text{min}$ to 50,000 $\mu\text{l}/\text{min}$ as compared with the conventional case in which the specimen material solution 16 is sent in a low flow rate region.

[0096] Moreover, in the case in which the specimen material solution 16 is sent at a flow rate that exceeds 50,000 $\mu\text{l}/\text{min}$, an extremely large solution sending ability is required for the solution sending pump 14, and an extremely high pressure is applied to the fine flow passage 2. Consequently, an extremely high manufacturing quality is required for the

fine flow passage **2** that includes the reaction field **4**, whereby it is difficult to configure the microchip solution sending system suitable for practical use. Therefore, it is preferable that a rate of flow of the specimen material solution **16** is equal to or less than 50,000 $\mu\text{l}/\text{min}$.

[0097] As described above in detail, for the microchip solution sending system **10** in accordance with the present invention, in the case in which a rate of flow of the specimen material solution **16** that is sent by the solution sending pump **14** is in the range of a high flow rate region of 1,000 $\mu\text{l}/\text{min}$ to 50,000 $\mu\text{l}/\text{min}$, the reaction efficiency can be improved. Moreover, the dispersion of a reaction amount between individual pieces of the analytes that are detected can be suppressed from occurring for the microchip solution sending systems **10** of the same specification, whereby the detection accuracy can be improved.

[0098] The microchip solution sending system **10** in accordance with the present embodiment described above is a microchip solution sending system of so-called a reciprocation type. However, the microchip solution sending system **10** in accordance with the present invention is not restricted to the above configuration, and the microchip solution sending system **10** in accordance with the present invention can also be configured as a microchip solution sending system of so-called a circulation type as shown in FIG. **8**.

[0099] The microchip solution sending system **10** in accordance with the present invention shown in FIG. **8** is different from the conventional microchip solution sending system **100** of a circulation type shown in FIG. **9** described above at the point of that the specimen material solution container **18** also functions as the mixing part **20**.

[0100] In other words, for the microchip solution sending system **10** of a circulation type shown in FIG. **8**, the outlet side flow passage **12** is not connected directly to the solution sending pump **14** and is connected to the solution sending pump **14** via the specimen material solution container **18** unlike the conventional microchip solution sending system **100** of a circulation type. By the above configuration, the specimen material solution **16** that is flown via the outlet side flow passage **12** and that is stored in the specimen material solution container **18** on a temporary basis is stirred. Conse-

[0101] For a wide variety of numerical value ranges in accordance with the present specification, the numerical value itself is also included in the numerical value range. For instance, 1,000 $\mu\text{l}/\text{min}$ to 50,000 $\mu\text{l}/\text{min}$ means that it is equal to or larger than 1,000 $\mu\text{l}/\text{min}$ and equal to or less than 50,000 $\mu\text{l}/\text{min}$.

EMBODIMENTS

[0102] The result of the simulation that has been carried out to confirm the effect of the microchip solution sending system **10** in accordance with the present invention will be described in the following.

Embodiment 1

[0103] In the present embodiment, for the microchip solution sending system **10** described above, the reaction amount in a unit area was simulated in the case in which a width of the flow passage of the fine flow passage **2** is 1 mm, a height of the flow passage of the fine flow passage **2** is 50 μm , and a flow rate of the specimen material solution **16** is in a low flow rate region of 100 $\mu\text{l}/\text{min}$, 300 $\mu\text{l}/\text{min}$, and 500 $\mu\text{l}/\text{min}$ (a comparative example) and is in a high flow rate region of 1,000 $\mu\text{l}/\text{min}$, 5,000 $\mu\text{l}/\text{min}$, 10,000 $\mu\text{l}/\text{min}$, 30,000 $\mu\text{l}/\text{min}$, and 50,000 $\mu\text{l}/\text{min}$ (the present embodiment).

[0104] The result of a simulation of the embodiment 1 is shown in FIG. **6** and Table 3.

[0105] A vertical axis of FIG. **6** represents a reaction amount in a unit area of the reaction field **4**, and a horizontal axis represents a measuring time. The conditions of an effective antibody density of the reaction field **4** and an amount of an antibody in the specimen material solution **16** in the case of the present embodiment are set to be equivalent to those in the case of the comparative example.

(Conditions)

[0106] Measuring time: 1500 sec

Width of a flow passage: 1 mm

Height of a flow passage: 50 μm

Shape of a reaction field: 1 mm \times 2 mm

Amount of a specimen material solution: 100 μl

TABLE 3

Flow rate ($\mu\text{l}/\text{min}$)	Amount of a specimen material solution (μl)	Effective antibody density (mol/cm^2)	Amount of an antigen (pg)	Number of passing (times/min)	Reaction amount in a unit area (pg/mm^2)	Note
100	100	6.70×10^{-12}	0.0175	1	0.00164	Comparative example
300				3	0.00187	
500				5	0.00196	
1,000				10	0.00223	Embodiment
5,000				50	0.00229	
10,000				100	0.00236	
30,000				300	0.00244	
50,000				500	0.00247	

quently, the specimen material solution container **18** also performs a function equivalent to that of the mixing part **20** in accordance with the embodiment described above, whereby the specimen material solution **16** in the range of a high flow rate region of 1,000 $\mu\text{l}/\text{min}$ to 50,000 $\mu\text{l}/\text{min}$ can be sent in a repetitive manner without reducing the reaction efficiency.

[0107] Table 4 indicates a result of an actual measurement of the fluorescence intensity in the case in which a flow rate of the specimen material solution **16** is in a low flow rate region of 100 $\mu\text{l}/\text{min}$, 300 $\mu\text{l}/\text{min}$, and 500 $\mu\text{l}/\text{min}$ (a comparative example) and is in a high flow rate region of 1,000 $\mu\text{l}/\text{min}$, 5,000 $\mu\text{l}/\text{min}$, 10,000 $\mu\text{l}/\text{min}$, 30,000 $\mu\text{l}/\text{min}$, and 50,000

$\mu\text{l}/\text{min}$ (the present embodiment) for the SPFS apparatus that is provided with the microchip solution sending system **10** in which a width of the flow passage of the fine flow passage **2** is 1 mm and a height of the flow passage of the fine flow passage **2** is 50 μm .

rate of the specimen material solution **16** is in a low flow rate region of 100 $\mu\text{l}/\text{min}$, 300 $\mu\text{l}/\text{min}$, and 500 $\mu\text{l}/\text{min}$ (a comparative example) and is in a high flow rate region of 1,000 $\mu\text{l}/\text{min}$, 5,000 $\mu\text{l}/\text{min}$, 10,000 $\mu\text{l}/\text{min}$, 30,000 $\mu\text{l}/\text{min}$, and 50,000 $\mu\text{l}/\text{min}$ (the present embodiment).

TABLE 4

Flow rate ($\mu\text{l}/\text{min}$)	Amount of a specimen material solution (μl)	Effective antibody density (mol/cm^2)	Amount of an antigen (pg)	Number of passing (times/min)	Fluorescence intensity	Note
100	100	6.70×10^{-12}	0.0175	1	30,100	Comparative example
300				3	34,200	
500				5	35,900	
1,000				10	40,800	Embodiment
5,000				50	41,900	
10,000				100	43,100	
30,000				300	44,700	
50,000				500	45,100	

[0108] As clarified by FIG. 6 and Table 3, at the point of time when a measuring time (1500 sec) elapses, as a rate of flow is higher, a reaction amount in a unit area is larger. A tendency of the simulation result can also be confirmed by a result of an actual measurement of the fluorescence intensity shown in Table 4.

[0109] As clarified by FIG. 6 and Table 3, a variation of a reaction amount that is associated with a variation of a rate of flow is smaller in the case of a high flow rate region (the present embodiment) as compared with the case of a low flow rate region (a comparative example). The tendency of the simulation result can also be confirmed by a result of an actual measurement of the fluorescence intensity shown in Table 4.

Embodiment 2

[0110] In the present embodiment, for the microchip solution sending system **10** described above, the reaction amount in a unit area was simulated in the case in which a width of the

[0111] The result of a simulation of the embodiment 2 is shown in FIG. 8 and Table 5.

[0112] A vertical axis of FIG. 7 represents a reaction amount in a unit area of the reaction field **4**, and a horizontal axis represents a measuring time. The conditions of an effective antibody density of the reaction field **4** and an amount of an antibody in the specimen material solution **16** in the case of the present embodiment are set to be equivalent to those in the case of the comparative example.

(Conditions)

[0113] Measuring time: 1500 sec

Width of a flow passage: 3 mm

Height of a flow passage: 500 μm

Shape of a reaction field: 3 mm \times 2 mm

Amount of a specimen material solution: 100 it

TABLE 5

Flow rate ($\mu\text{l}/\text{min}$)	Amount of a specimen material solution (μl)	Effective antibody density (mol/cm^2)	Amount of an antigen (pg)	Number of passing (times/min)	Fluorescence intensity	Note
100	100	6.70×10^{-12}	0.0175	1	0.00118	Comparative example
300				3	0.00135	
500				5	0.00142	
1,000				10	0.00161	Embodiment
5,000				50	0.00166	
10,000				100	0.00170	
30,000				300	0.00176	
50,000				500	0.00179	

flow passage of the fine flow passage **2** is 3 mm, a height of the flow passage of the fine flow passage **2** is 500 μm , and a flow

[0114] Table 6 indicates a result of an actual measurement of the fluorescence intensity in the case in which a flow rate of

the specimen material solution **16** is in a low flow rate region of 100 $\mu\text{l}/\text{min}$, 300 $\mu\text{l}/\text{min}$, and 500 $\mu\text{l}/\text{min}$ (a comparative example) and is in a high flow rate region of 1,000 $\mu\text{l}/\text{min}$, 5,000 $\mu\text{l}/\text{min}$, 10,000 $\mu\text{l}/\text{min}$, 30,000 $\mu\text{l}/\text{min}$, and 50,000 $\mu\text{l}/\text{min}$ (the present embodiment) for the SPFS apparatus that is provided with the microchip solution sending system **10** in which a width of the flow passage of the fine flow passage **2** is 3 mm and a height of the flow passage of the fine flow passage **2** is 500 μm .

indicates a result of a simulation in the case in which a measuring time (sec) is 5400 seconds. The conditions of an amount of the specimen material solution **16**, an effective antibody density and an amount of an antibody in the specimen material solution **16** and others are set to be equivalent to those in the case of the embodiment described above. A variation coefficient CV value (%) is obtained by dividing a standard deviation by an arithmetic mean value and indicates a relative dispersion.

TABLE 6

Flow rate ($\mu\text{l}/\text{min}$)	Amount of a specimen material solution (μl)	Effective antibody density (mol/cm^2)	Amount of an antigen (pg)	Number of passing (times/min)	Fluorescence intensity	Note
100	100	6.70×10^{-12}	0.0175	1	21,600	Comparative example
300				3	24,700	
500				5	25,900	
1,000				10	29,300	Embodiment
5,000				50	30,300	
10,000				100	31,200	
30,000				300	32,300	
50,000				500	32,700	

[0115] As clarified by FIG. 7 and Table 5, at the point of time when a measuring time (1500 sec) elapses, as a rate of flow is higher, a reaction amount in a unit area is larger. A tendency of the simulation result can also be confirmed by a result of an actual measurement of the fluorescence intensity shown in Table 6.

[0116] As clarified by FIG. 7 and Table 5, a variation of a reaction amount that is associated with a variation of a rate of flow is smaller in the case of a high flow rate region (the present embodiment) as compared with the case of a low flow rate region (a comparative example). The tendency of the simulation result can also be confirmed by a result of an actual measurement of the fluorescence intensity shown in Table 6.

Embodiment 3

[0117] A variation of a reaction amount that is associated with a variation of a rate of flow is decreased in the case in which a rate of flow of the specimen material solution is in the range of a high flow rate region. This will be described in detail in the following embodiment.

[0118] Tables 7 and 8 show a variation of a reaction amount with a variation coefficient CV value in the case in which a rate of flow is varied by +10% to the predetermined rate of flow ($\mu\text{l}/\text{min}$). More specifically, for each of the three reaction fields **4** with difference shapes (1 mm \times 2 mm, 2 mm \times 2 mm, and 3 mm \times 2 mm), a CV value was obtained by a simulation in the case in which a rate of flow ($\mu\text{l}/\text{min}$) of the specimen material solution **16** is varied by $\pm 10\%$ from 50,000 $\mu\text{l}/\text{min}$, in the case in which a rate of flow ($\mu\text{l}/\text{min}$) of the specimen material solution **16** is varied by $\pm 10\%$ from 10,000 $\mu\text{l}/\text{min}$, in the case in which a rate of flow ($\mu\text{l}/\text{min}$) of the specimen material solution **16** is varied by $\pm 10\%$ from 1,000 $\mu\text{l}/\text{min}$, in the case in which a rate of flow ($\mu\text{l}/\text{min}$) of the specimen material solution **16** is varied by $\pm 10\%$ from 800 $\mu\text{l}/\text{min}$, and in the case in which a rate of flow ($\mu\text{l}/\text{min}$) of the specimen material solution **16** is varied by +10% from 100 $\mu\text{l}/\text{min}$.

[0119] Table 7 indicates a result of a simulation in the case in which a measuring time (sec) is 600 seconds. Table 8

TABLE 7

Measuring time (sec)	Shape of a reaction field	Flow rate ($\mu\text{l}/\text{min}$)	CV value (%)	Note
600	1 mm \times 2 mm	50,000 $\pm 10\%$	0.27	Embodiment
		10,000 $\pm 10\%$	0.32	
		1,000 $\pm 10\%$	0.50	
	2 mm \times 2 mm	800 $\pm 10\%$	1.02	Comparative example
		100 $\pm 10\%$	1.45	
		50,000 $\pm 10\%$	0.31	Embodiment
		10,000 $\pm 10\%$	0.33	
		1,000 $\pm 10\%$	0.56	
		800 $\pm 10\%$	1.20	
	3 mm \times 2 mm	100 $\pm 10\%$	1.60	Comparative example
		50,000 $\pm 10\%$	0.32	
		10,000 $\pm 10\%$	0.35	Embodiment
		1,000 $\pm 10\%$	0.58	
		800 $\pm 10\%$	1.22	
		100 $\pm 10\%$	1.67	

TABLE 8

Measuring time (sec)	Shape of a reaction field	Flow rate ($\mu\text{l}/\text{min}$)	CV value (%)	Note
5400	1 mm \times 2 mm	50,000 $\pm 10\%$	0.12	Embodiment
		10,000 $\pm 10\%$	0.14	
		1,000 $\pm 10\%$	0.20	
	2 mm \times 2 mm	800 $\pm 10\%$	0.72	Comparative example
		100 $\pm 10\%$	0.91	
		50,000 $\pm 10\%$	0.07	Embodiment
		10,000 $\pm 10\%$	0.10	
		1,000 $\pm 10\%$	0.12	
		800 $\pm 10\%$	0.68	
	3 mm \times 2 mm	100 $\pm 10\%$	0.73	Comparative example
		50,000 $\pm 10\%$	0.03	
		10,000 $\pm 10\%$	0.05	Embodiment
		1,000 $\pm 10\%$	0.10	
		800 $\pm 10\%$	0.48	
		100 $\pm 10\%$	0.56	

[0120] As clarified by Table 7 and Table 8, a CV value is smaller in the case of a high flow rate region (the present embodiment) as compared with the case of a low flow rate region (a comparative example). It is confirmed that a dispersion of a reaction amount can be suppressed for a high flow rate region as compared with a flow rate variation of the same level. This is similar in the case in which a measuring time (a reaction time) is shorter (Table 7) or longer (Table 8). In the case in which a measuring time (a reaction time) is longer, a dispersion of a reaction amount is smaller on the whole. This is because a saturation point is reached in the case in which a measuring time (a reaction time) is longer, whereby a dispersion of a reaction amount is smaller. Even in such a situation, it can be confirmed that an effect of suppressing a dispersion of a reaction amount is high by definition in a high flow rate region of 1,000 $\mu\text{l}/\text{min}$ to 50,000 $\mu\text{l}/\text{min}$.

[0121] Although an amount of the specimen material solution, and an effective antibody density and an amount of an antibody in the specimen material solution have been described by using a certain example in the embodiment described in detail above, a similar tendency is indicated even in the case in which the values are varied.

REFERENCE SIGNS LIST

[0122] 2: Fine flow passage
 [0123] 4: Reaction field
 [0124] 6: Inlet hole
 [0125] 8: Outlet hole
 [0126] 10: Microchip solution sending system
 [0127] 12: Outlet side flow passage
 [0128] 14: Solution sending pump
 [0129] 15: Control part
 [0130] 16: Specimen material solution
 [0131] 18: Specimen material solution container
 [0132] 20: Mixing part
 [0133] 22: Pipette
 [0134] 22a: End
 [0135] 22b: Base end part
 [0136] 30: Analyte
 [0137] 32: Antigen
 [0138] 100: Microchip solution sending system
 [0139] 102: Fine flow passage
 [0140] 104: Reaction field
 [0141] 106: Inlet hole
 [0142] 108: Outlet hole
 [0143] 110: Inlet side flow passage
 [0144] 112: Outlet side flow passage
 [0145] 114: Circulation solution sending pump
 [0146] 116: Specimen material solution
 [0147] 118: Specimen material solution container
 [0148] 200: Microchip solution sending system
 [0149] 202: Fine flow passage
 [0150] 204: Reaction field
 [0151] 206: Inlet hole
 [0152] 208: Outlet hole
 [0153] 210: Inlet side flow passage
 [0154] 212: Outlet side flow passage
 [0155] 214: Reciprocation solution sending pump

[0156] 216: Specimen material solution
 [0157] 218: Specimen material solution container
 [0158] gl: Air-liquid interface
 [0159] ul: Height of the upper face of a flow passage of a fine flow passage
 [0160] H: Height of the flow passage
 [0161] v: Velocity of flow
 [0162] l: Diffusion distance
 [0163] L1: Length of a flow passage of a fine flow passage
 [0164] D: Width of a flow passage of a fine flow passage
 [0165] H: Height of a flow passage of a fine flow passage
 [0166] L2: Length of a reaction field

What is claimed is:

1. A microchip solution sending system comprising:

a flow passage that is provided with a reaction field to which an antibody that reacts with a specific antigen is fixed; and a solution sending pump that is configured to send a specimen material solution that includes the specific antigen,

wherein the specimen material solution passes through the reaction field of the flow passage in a repetitive manner in the case in which the solution sending pump sends the specimen material solution, and

a flow rate of the specimen material solution that is sent by the solution sending pump is in the range of 1,000 $\mu\text{l}/\text{min}$ to 50,000 $\mu\text{l}/\text{min}$.

2. The microchip solution sending system of claim 1, further comprising a mixing part that is connected to the flow passage in which the specimen material solution that has passed through the reaction field of the flow passage is stored temporarily and the specimen material solution that has been stored is stirred.

3. The microchip solution sending system of claim 1, wherein:

a cross section of the flow passage is in a rectangular shape, and

a width of the flow passage is in the range of 0.5 mm to 3 mm and

a height of the flow passage is in the range of 50 μm to 500 μm .

4. The microchip solution sending system of claim 2, wherein:

a cross section of the flow passage is in a rectangular shape, and

a width of the flow passage is in the range of 0.5 mm to 3 mm and

a height of the flow passage is in the range of 50 μm to 500 μm .

5. The microchip solution sending system of claim 1, wherein a flow rate of the specimen material solution that is sent by the solution sending pump is in the range of 5,000 $\mu\text{l}/\text{min}$ to 50,000 $\mu\text{l}/\text{min}$.

6. The microchip solution sending system of claim 2, wherein a flow rate of the specimen material solution that is sent by the solution sending pump is in the range of 5,000 $\mu\text{l}/\text{min}$ to 50,000 $\mu\text{l}/\text{min}$.

7. The microchip solution sending system of claim 3, wherein a flow rate of the specimen material solution that is sent by the solution sending pump is in the range of 5,000 $\mu\text{l}/\text{min}$ to 50,000 $\mu\text{l}/\text{min}$.

8. The microchip solution sending system of claim 4, wherein a flow rate of the specimen material solution that is sent by the solution sending pump is in the range of 5,000 $\mu\text{l}/\text{min}$ to 50,000 $\mu\text{l}/\text{min}$.

9. A specimen material detection apparatus comprising the microchip solution sending system of claim 1.

10. The specimen material detection apparatus of claim 9, wherein the specimen material detection apparatus is a surface plasmon resonance apparatus (a SPR apparatus) or a surface plasmon field enhanced fluorescence spectroscopic measurement apparatus (a SPFS apparatus).

* * * * *