



US 20070101483A1

(19) **United States**

(12) **Patent Application Publication**
Ohba

(10) **Pub. No.: US 2007/0101483 A1**

(43) **Pub. Date: May 10, 2007**

(54) **TOILET SEAT PAPER SETTING METHOD,
APPARATUS THEREFOR AND TOILET SEAT
PAPER**

(30) **Foreign Application Priority Data**

Dec. 22, 2003 (JP) 2003-423949

Jan. 22, 2004 (JP) 2004-000221

(75) Inventor: **Shunji Ohba**, Shizuoka-ken (JP)

Publication Classification

Correspondence Address:
LEYDIG VOIT & MAYER, LTD
700 THIRTEENTH ST. NW
SUITE 300
WASHINGTON, DC 20005-3960 (US)

(51) **Int. Cl.**
A47K 13/14 (2006.01)

(52) **U.S. Cl.** **4/245.1**

(57) **ABSTRACT**

(73) Assignee: **Kabushikigaisya Ohba**, Shimada-shi (JP)

A toilet seat paper setting method and device for a toilet seat wherein paper sheets can be easily supplied to and removed from the toilet seat. A toilet cover includes a paper cassette with paper sheets, which are placed to cover the seat surface of the toilet seat and stored in the cassette, stacked in many layers, and can be taken out one-by-one. A number of air suction holes in the toilet seat open to the seat surface of the toilet seat. An air suction device draws air through the suction holes. With the toilet cover fitted to the toilet seat, the suction device is actuated to cause a paper sheet in the paper cassette to be sucked onto the toilet seat.

(21) Appl. No.: **10/583,332**

(22) PCT Filed: **Dec. 22, 2004**

(86) PCT No.: **PCT/JP04/19173**

§ 371(c)(1),
(2), (4) Date: **Jan. 29, 2007**

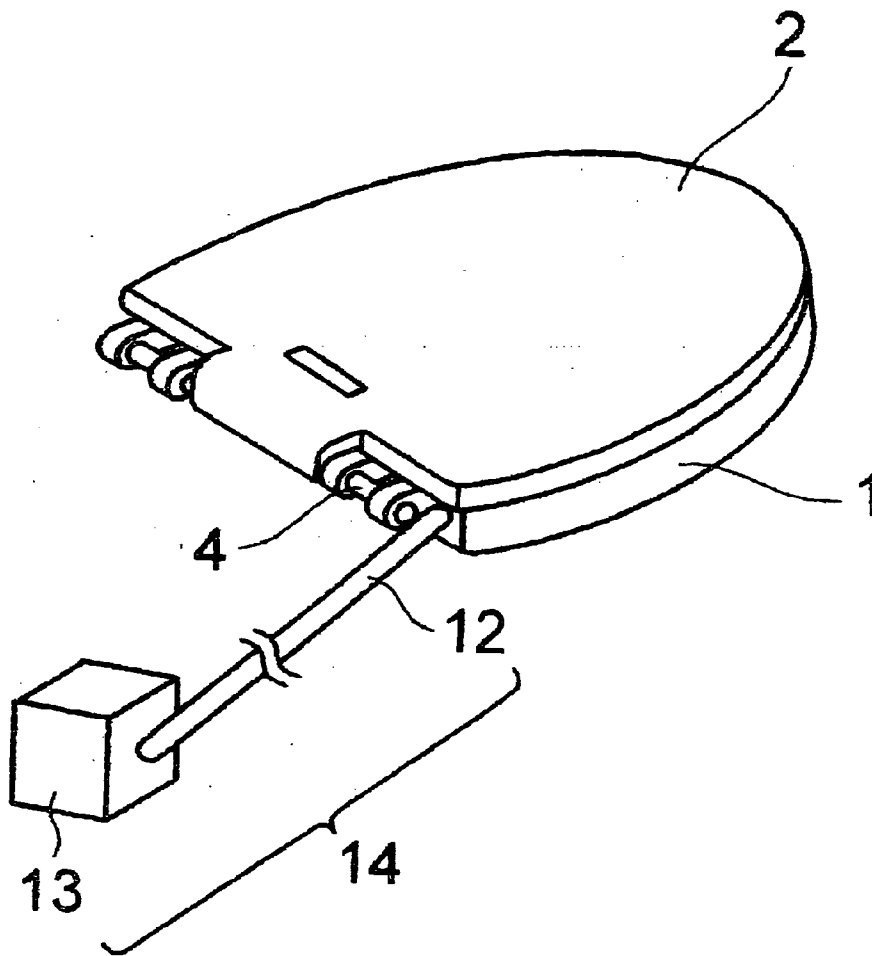

Fig 1

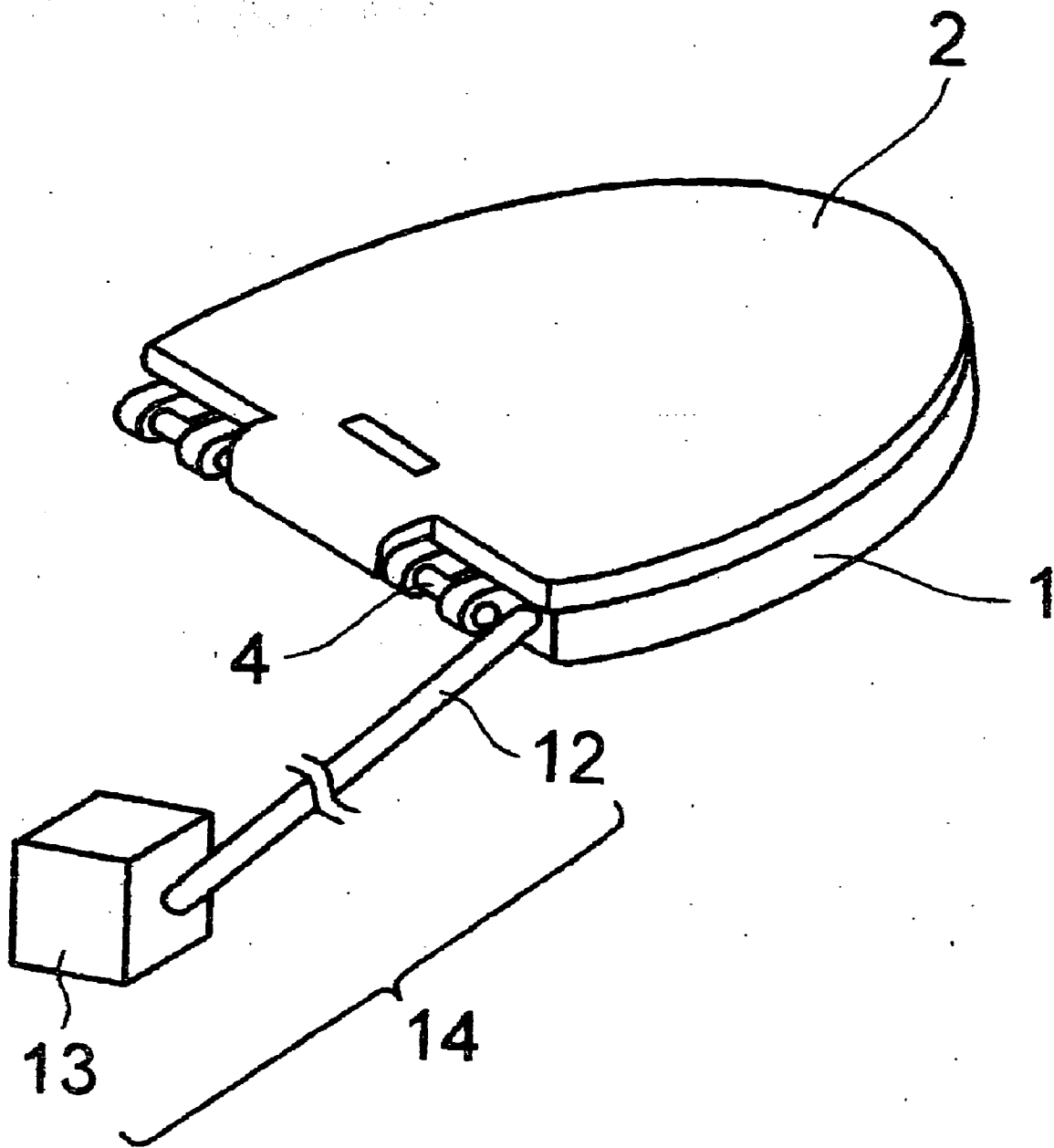

Fig. 2

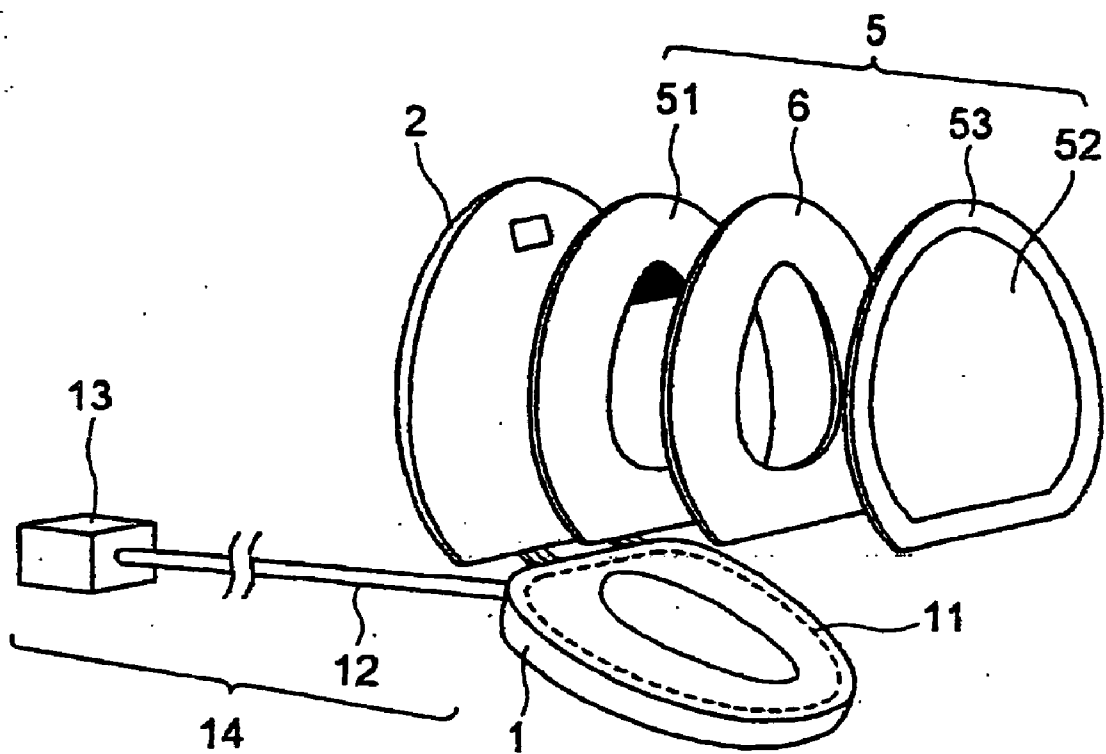

Fig. 3

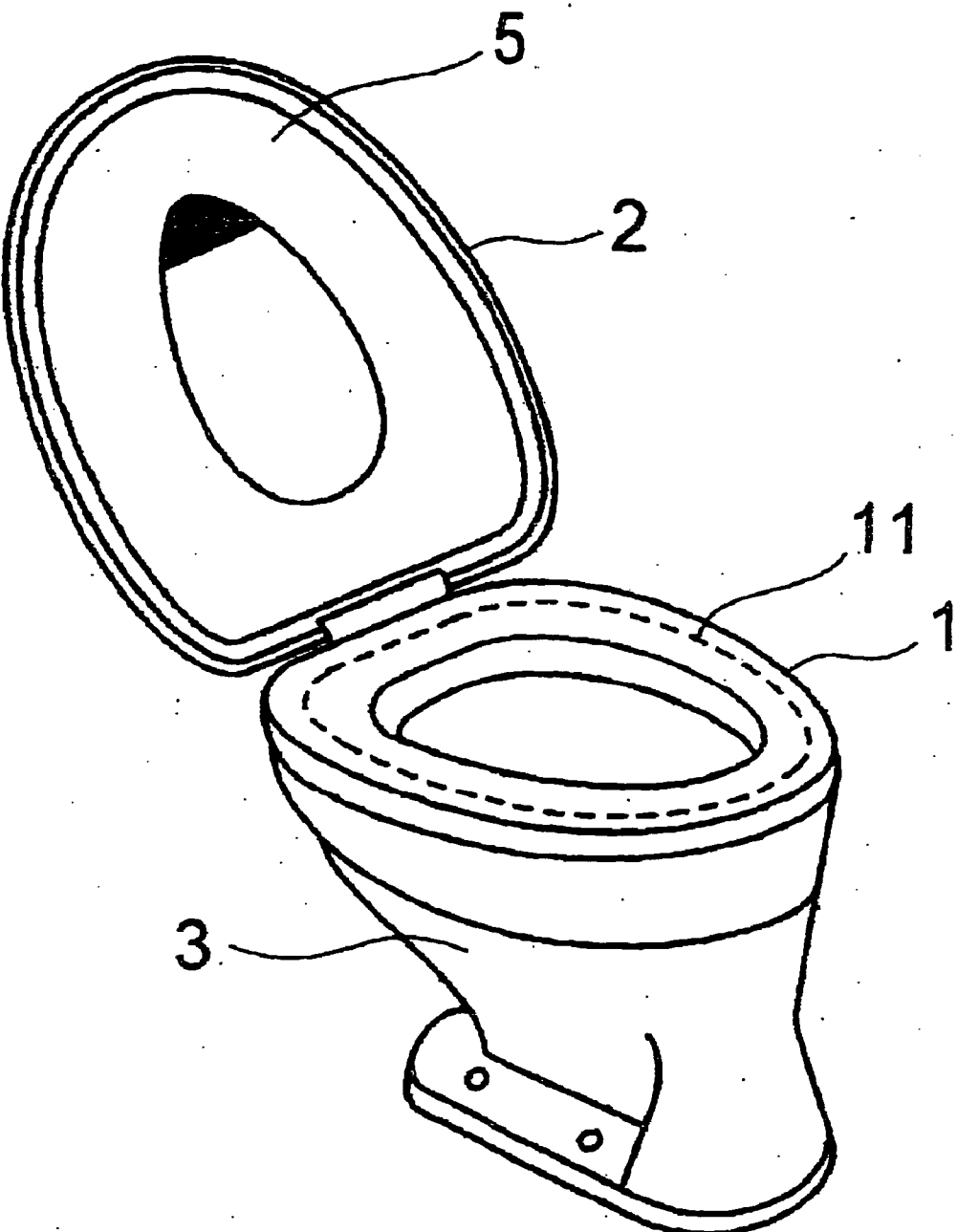

Fig. 4

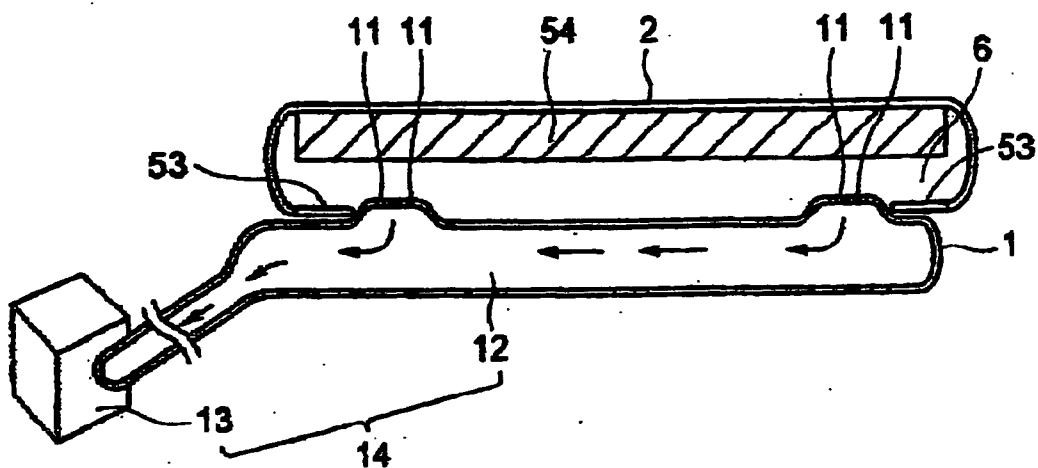

Fig. 5

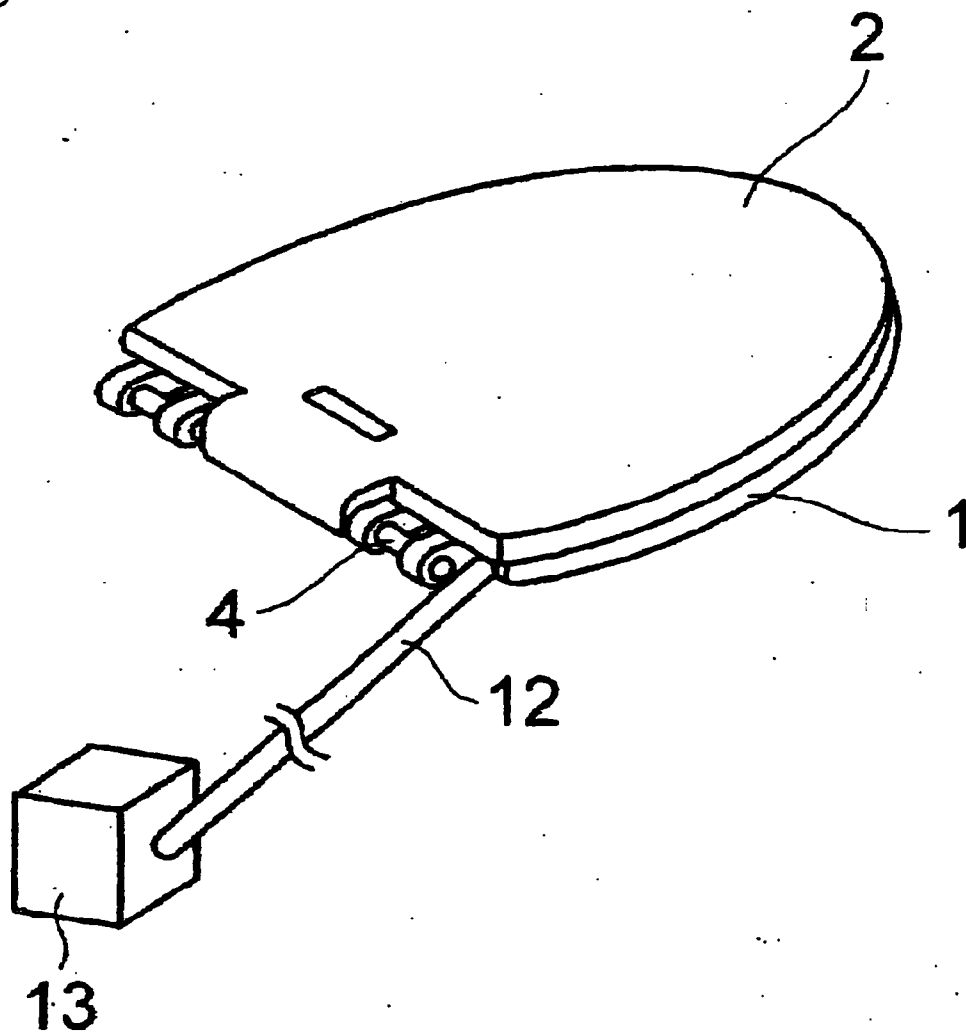

Fig. 6

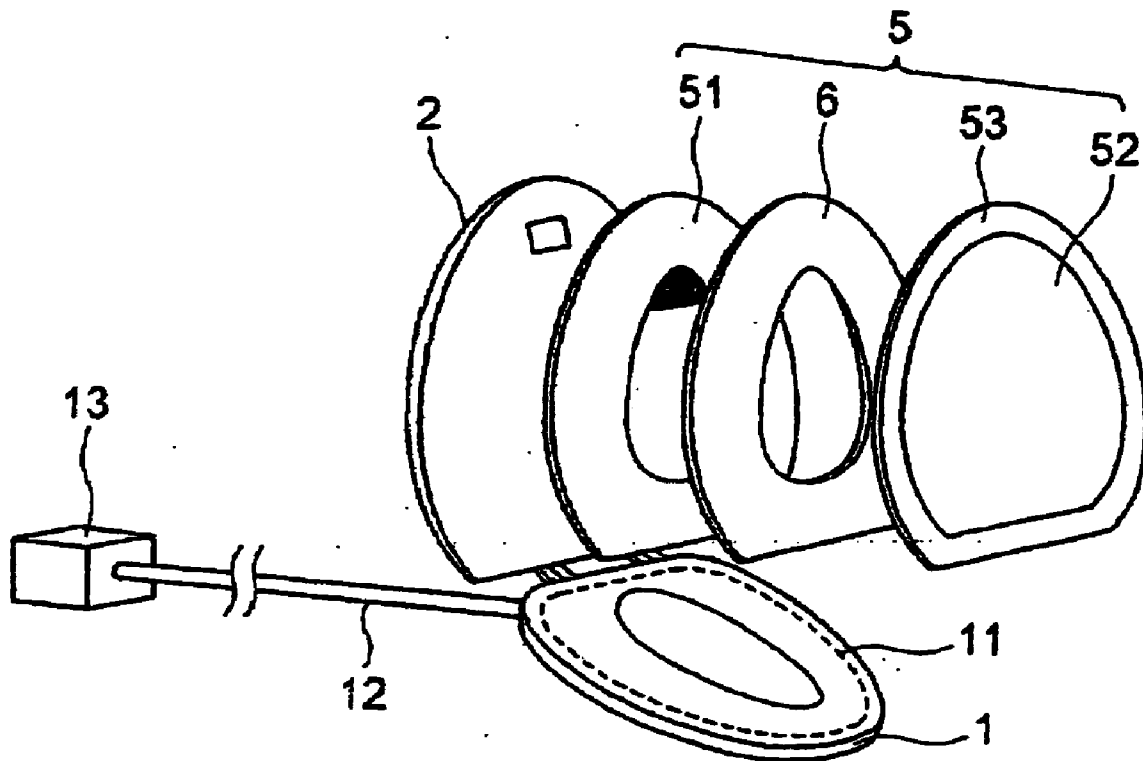

Fig. 7

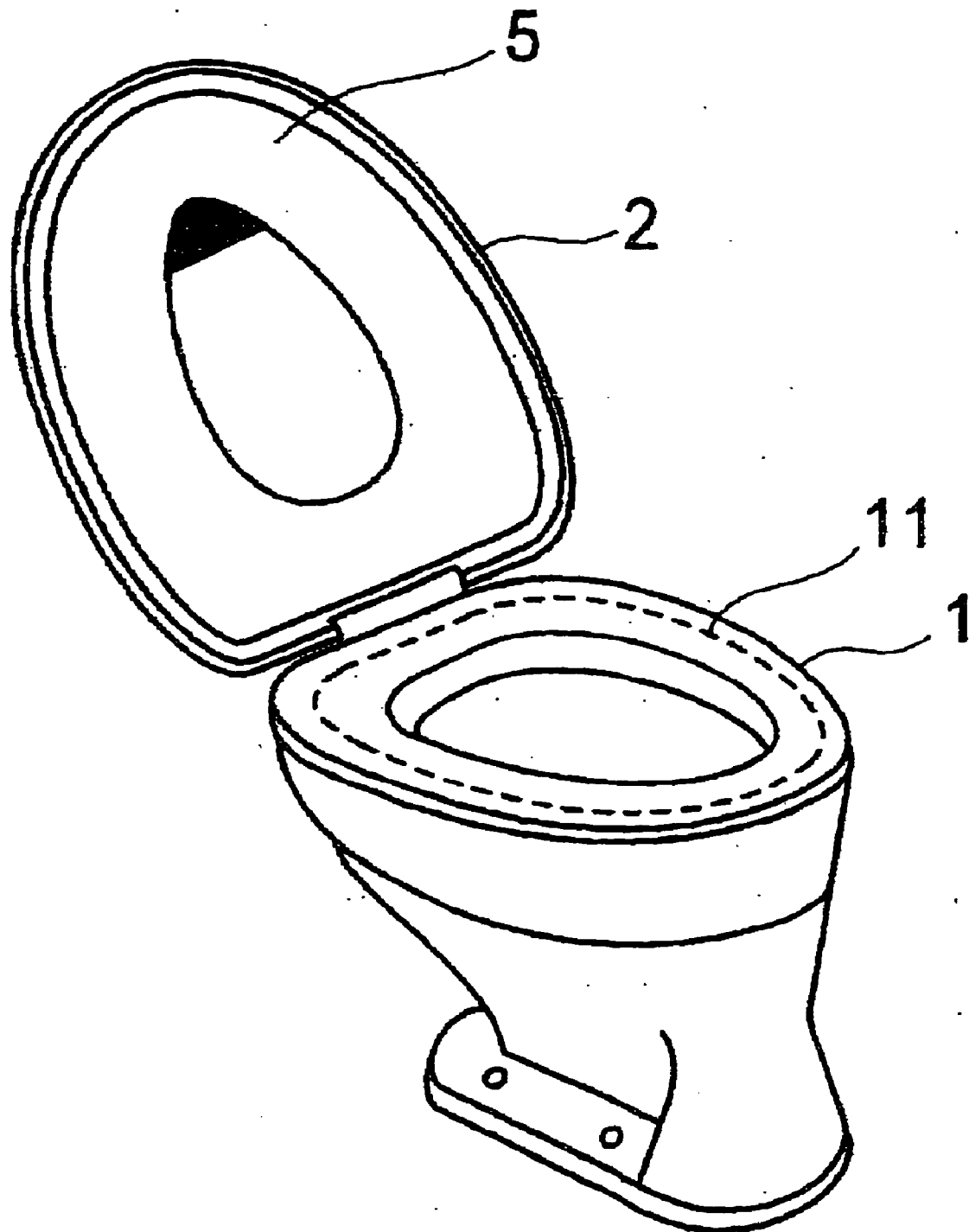

Fig. 8

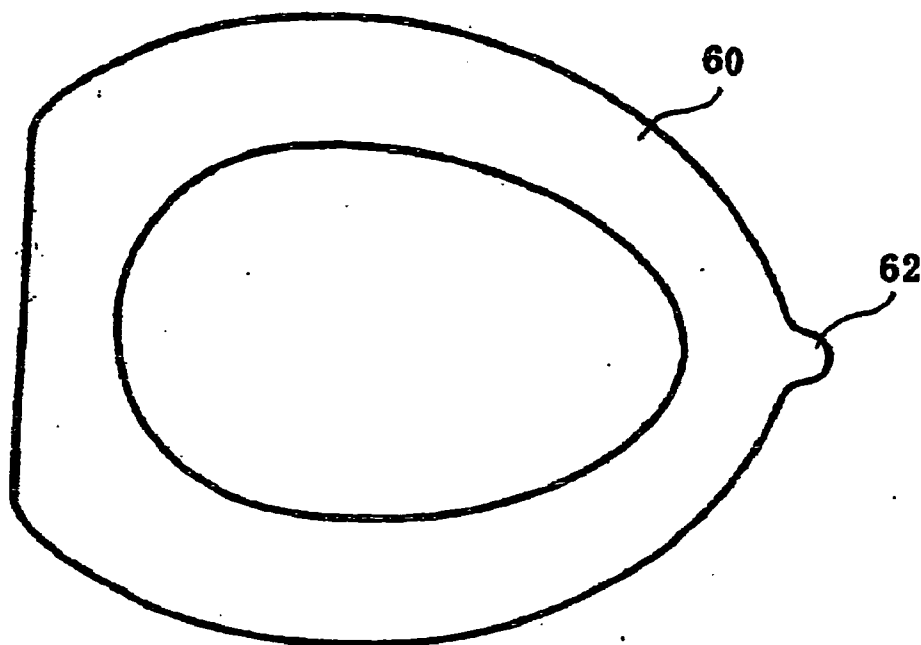
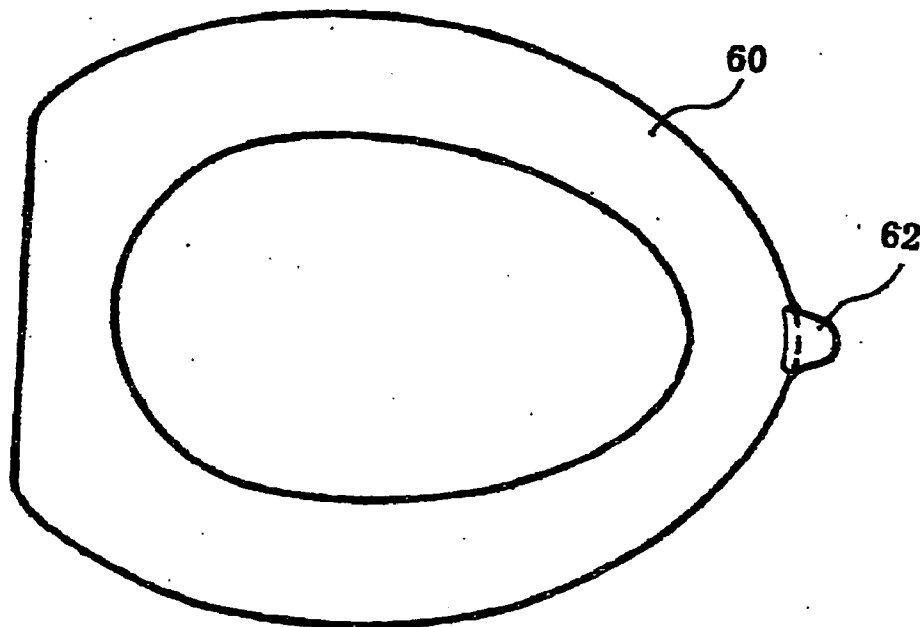

Fig. 9



**TOILET SEAT PAPER SETTING METHOD,
APPARATUS THEREFOR AND TOILET SEAT
PAPER**

TECHNICAL FIELD

[0001] This invention relates to a method and an apparatus for setting a toilet seat paper on a toilet seat and a toilet seat paper.

BACKGROUND ART

[0002] Western style toilet apparatus which is rapidly spreading is considered to have a sanitary problem in that the user directly sits on a toilet seat differing from the Japanese style toilet especially in a department stores or hotels in which non-specific users frequently use.

[0003] As measures for solving this, various arrangements for replacing a sheet of paper place on the toilet seat are proposed. See Japanese Utility Model Registration No. 3013477 (Utility Model Document 1) and Japanese Utility Model Registration No. 3072648 (Utility Model Document 2), for example.

[0004] However, the former requires to page toilet seat cover sheets or the toilet seat papers by means of toilet seat cover sheet paging machine and a feed operation magnet must be magnetically attached to a magnetized element attached to the toilet main body, so that the operation is troublesome and the toilet seat paper may easily broken during the operation.

[0005] Also, since the latter has such the arrangement that a number of toilet seat papers are stacked into a lamination, each paper being provided with a separation portion on the use surface and an adhesive portion on the other surface, whereby the toilet seat paper is adhered to the toilet seat, there has been problems that steps of providing the toilet seat papers with the separation portion and the adhesive portion are complicated and increases the cost, and that the paper separation and removal step is burdensome in that the adhered toilet seat paper cannot easily be separated and is often broken.

[0006] Further, in either case, the toilet seat paper placed on the toilet seat must be separated after the usage, the conventional toilet seat paper becomes wet with sweat and sticks to the toilet seat or the toilet seat paper is twisted during the usage and becomes difficult to grasp, often providing annoyance to the user.

Utility Model Reference 1

[0007] Japanese Utility Model Registration No. 3013477 Publication

Utility Model Reference 2

[0008] Japanese Utility Model Registration No. 3072648 Publication

DISCLOSURE OF INVENTION

Problem To Be Solved By The Invention

[0009] This invention has as its object the provision of a method and an apparatus for setting a toilet seat paper on a

toilet seat and a toilet seat paper in which a toilet seat paper can be easily fed onto a toilet seat and easily removed from the toilet seat.

Measure For Solving The Problems

[0010] The present invention is characterized by comprising a toilet cover equipped with a paper cassette in which a number of toilet seat papers, which are to be placed to cover the seat surface of a toilet seat, are contained in stacked layers separable one by one into a separate paper sheet, a number of air suction holes disposed in said toilet seat to open in the seat surface of said toilet seat, and air suction means for sucking air through said suction holes, wherein said paper sheet in said paper cassette is attached by suction to said toilet seat by the action of said air suction means with said toilet cover placed on said toilet seat.

[0011] The present invention is characterized in that said toilet seat comprises an upper member and a lower member and said toilet seat provided with said air suction holes comprises said upper member.

[0012] The present invention is characterized in that said toilet seat provided with said air suction holes is arranged for coaxial rotation with said toilet cover.

[0013] The present invention is characterized in that said toilet seat provided with said air suction holes is formed with a thermally insulating material.

[0014] The present invention is characterized in that said air suction holes open in said seat surface of the toilet seat are fine holes difficult to recognize by naked eyes.

[0015] The present invention is characterized in that said air suction means comprises an air suction device disposed inside or outside of a toilet main body, and an air suction passage disposed within said toilet seat for communicating said air suction device and said air suction holes.

[0016] The present invention is characterized by comprising a sensor for detecting user's entry into and exit from a toilet bowl nearby region and control means for activating said air suction means on the basis of an entry signal from said sensor and deactivating said air suction means on the basis of an exit signal.

[0017] The present invention is characterized in that said paper cassette comprises a container portion containing said toilet seat papers stacked in layers, a paper passing frame member having an opening allowing said toilet seat papers passing therethrough one by one and detachably fitted to said container portion, and an elastic member disposed between said contained toilet papers stacked in layers and said container portion for urging said stacked toilet seat papers against said paper passing frame member.

[0018] The present invention is characterized in that, in a toilet seat paper setting device comprising a toilet cover equipped with a paper cassette in which a number of toilet seat papers, which are to be placed to cover the seat surface of a toilet seat, are contained in stacked layers separable one by one into a separate paper sheet, a number of air suction holes disposed in said toilet seat to open in the seat surface of said toilet seat, and air suction means for sucking air through said suction holes, a sensor for detecting user's entry into and exit from a toilet bowl nearby region, and control means for activating said air suction means on the

basis of an entry signal from said sensor, said air suction means is kept activated by said control means on the basis of said entry signal from said sensor, and that, upon opening said toilet seat, only the toilet seat paper attached by suction to said toilet seat by the suction of said air suction holes when said toilet seat is closed is separated from the laminated toilet papers contained within said paper cassette.

[0019] The present invention is characterized in that said air suction means is activated at least during an user remains seated on said toilet seat to keep said toilet seat paper attached by suction to said toilet seat.

[0020] The present invention is characterized in that, using a toilet seat paper setting device comprising a toilet cover equipped with a paper cassette in which a number of toilet seat papers, which are to be placed to cover the seat surface of a toilet seat, are contained in stacked layers separable one by one into a separate paper sheet, a number of air suction holes disposed in said toilet seat to open in the seat surface of said toilet seat, and air suction means for sucking air through said suction holes, a sensor for detecting user's entry into and exit from a toilet bowl nearby region, and control means for activating said air suction means on the basis of an entry signal from said sensor and deactivating said air suction means on the basis of an exit signal, said air suction means is kept activated by said control means after reception of said entry signal from said sensor until reception of said exit signal.

[0021] The present invention is characterized in that, in a toilet seat paper to be placed on a toilet seat surface for covering it, a projection portion capable of being held by at least finger tips is provided at one portion of an outer peripheral edge of said toilet seat paper to extend outwardly therefrom.

[0022] The present invention is characterized in that said projection portion has a substantially U-shaped configuration.

[0023] The present invention is characterized in that said projection portion is provided to position between user's legs when the user seats on said toilet seat.

[0024] The present invention is characterized in that said toilet seat paper is made of a water soluble material.

[0025] The present invention is characterized in that said toilet seat paper has an aroma constituent impregnated therein.

[0026] The present invention is characterized in that said toilet seat paper is configured into an annular shape.

[0027] The present invention is characterized in that said projection portion is formed in one piece with said toilet seat paper.

[0028] The present invention is characterized in that said projection portion is formed as a separate piece attached to the toilet seat paper.

Advantageous Results Of The Invention

[0029] According to the present invention, the toilet paper sheet is separated from the paper cassette by suction and attached to the toilet seat, so that the structure can be made

simpler with lesser breakdown as compared to the conventional design, enabling smoother and continuous feeding of the toilet seat papers.

[0030] According to the present invention, the toilet seat paper can be easily fed to the toilet seat without the need of manual operation and easily removed from the toilet seat by the user after the use.

[0031] According to the present invention, the toilet seat is made of a thermally insulating material, so that uncomfortable feeling due to cold toilet seat can be eliminated.

[0032] According to the present invention, the air suction holes are fine holes difficult to recognize by naked eyes, the presence of the air suction holes can be hidden from sight.

[0033] According to the present invention, upon the user sits on the toilet seat, the toilet seat paper is always set on the toilet seat without manual handling.

[0034] According to the present invention, the air suction means is kept activated during the use to maintain the toilet seat paper attached by suction, enabling to eliminate the uncomfortable feeling due to positional displacement.

[0035] According to the present invention, the projection portion can be picked to easily rip off the used toilet seat paper from the toilet seat.

[0036] According to the present invention, the projection portion is provided to position between the user's legs, so that the toilet seat paper can be easily picked by the user when he or she remains seated on said toilet seat, enabling to prevent the toilet seat paper from sticking to the skin of the rising user.

[0037] According to the present invention, the projection portion is provided to position between the user's legs, that is, the toilet seat paper can be separated from one end of the major axis of the generally eclipse toilet seat paper formed according to the toilet seat configuration, that is, the toilet seat paper having the major axis at its center can be separated along the central major axis, whereby the symmetrical toilet seat paper can be easily separated from the toilet seat without breaking it.

[0038] According to the present invention, the toilet seat paper is made of a water soluble material, so that the toilet seat paper can be thrown away into the toilet bowl.

[0039] According to the present invention, the toilet seat paper has an aroma constituent impregnated therein, so that bad smell can be suppressed and relieve oneself in comfort in an aromatic atmosphere.

[0040] According to the present invention, the toilet seat paper is configured into an annular shape, so that the toilet seat paper can be separated in its entirety by pulling the single projection portion.

[0041] According to the present invention, the projection portion is formed in one piece with the toilet seat paper, so that the breakage of the paper at the time of separating can be suppressed.

[0042] According to the present invention, the projection portion is formed as a separate piece attached to the toilet seat paper, the strength of the attached portion is increased, further suppressing the breakage of the paper at the time of separation.

BEST MODE FOR CARRYING OUT THE
INVENTION

[0043] The best mode for carrying out the invention will now be described on the basis of the embodiments of the present invention.

Embodiment 1

[0044] First, embodiment 1 will be described on the basis of FIGS. 1 to 4. FIG. 1 is a perspective view of an outer appearance of a toilet seat arranged assembled together with a toilet cover, FIG. 2 is an exploded perspective view of the toilet seat and a paper cassette contained within the toilet cover, FIG. 3 is a perspective view of an outer appearance of the toilet in the used state and FIG. 4 is a sectional view of the toilet seat.

[0045] In FIGS. 1 to 3, reference numeral 1 is a toilet seat, 2 is a toilet cover and 3 is a toilet bowl main body. The toilet seat 1 is freely rotatably attached to the toilet cover 2 through a pivot shaft 4 and assembled into one unit, and a paper cassette 5 is detachably provided at the back side of the toilet cover 2.

[0046] The paper cassette 5 comprises comprises a container portion 51 containing a stack of sheets of toilet seat papers 6 which are stacked in layers so that the sheet papers 6 formed in a ring-shape, for example, capable of covering the seat surface the toilet seat 1 may be separated one by one, and a paper passing frame member 53 arranged to hold an outer peripheral side of the toilet seat papers 6 contained in the container portion 51 and having formed therein an opening 52 for allowing the separated toilet seat papers 6 to pass therethrough to the seat surface side.

[0047] The paper cassette 5 illustrated in FIG. 4 comprises, not only the container portion 51 containing a stack of sheets of toilet seat papers 6 which are stacked in layers and a paper passing frame member 53 having formed therein an opening 52 for allowing the separated toilet seat papers 6 to pass therethrough one by one to the seat surface side and arranged to hold an outer peripheral side of the toilet seat papers 6 contained in the container portion 51, but also an elastic member 54 disposed between the contained toilet seat papers 6 stacked in layers and the container portion 51 for always urging the toilet seat papers 6 stacked within the container portion 51 toward the paper passing frame member 53. The elastic member 54 may be made of sponge, for example.

[0048] By using such the elastic member 54, the stack of the toilet seat paper 6 contained within the container portion 51 can be maintained without being disturbed, and the toilet seat paper 6 can be smoothly and stably fed until the last toilet seat paper 6 even when the amount of the papers become small.

[0049] In FIGS. 2 to 4, the toilet seat 1 has formed therein a large number of air suction holes 11 from the seat surface side toward the inside of the toilet seat 1 and the openings of these air suction holes 11 are made open in the seat surface. It is preferable to make the openings of the air suction holes 11 fine openings which are so small as to be difficult to recognize by naked eyes by the user from the view point of not providing an uncomfortable feeling of strangeness, but it is not necessary to make them fine holes.

[0050] An air suction means 14 comprises an air suction passage 12 disposed within the toilet seat 1 in communication with the suction holes 11 and an air suction device 13 suitably disposed outside of a toilet bowl main body 3 to which the air suction passage 12 is connected, and the activation of the air suction device 13 causes air to be sucked through the air suction holes 11 that are provided in a large number in the seat surface of the toilet seat 1 and through the air suction passage 12.

[0051] That is, when the air suction means 14 is activated in the state where the toilet cover 2 is place on the toilet seat 1, the toilet seat paper 6 in the paper cassette 5 is attached by suction to the seat surface of the toilet seat 1, and, when the toilet cover 2 is opened with the state in which the paper is attached by suction, the toilet bowl main body 3 is opened with a single sheet of the toilet seat paper 6 attached by suction to the toilet seat 1.

[0052] The activation of the air suction means 14 is achieved by a sensor (not shown) for detecting user's entry into and exit from a toilet bowl nearby region, such as at the entrance to the rest room and a door for an individual compartment, and control means (not shown) for activating the air suction means 14 on the basis of an entry signal from the sensor and deactivating the air suction means 14 on the basis of an exit signal.

[0053] For example, when the air suction means 14 is kept activated by the control means on the basis of the entry signal from the sensor and, upon opening of the toilet seat 1 in use, only the toilet seat paper 6, which is attached by suction to the toilet seat 1 by the suction of the air suction holes 11 when the toilet seat 1 is closed, is separated from the stack of the toilet papers 6 contained within the paper cassette 5 and place on the seat surface of the toilet seat 1 to cover it. That is, each time the toilet cover 2 is opened at the time of use, one sheet of the toilet seat paper 6 is set on the toilet seat 1.

[0054] The activation of the air suction means 14 by the control means is not limited to be achieved by activating it for a time interval between the incoming of the entry signal from the sensor and the incoming of the exit signal as in this embodiment 1, the control may be achieved in any other way. However, it is preferable that the air suction means 14 is activated at least during a user remains seated on the toilet seat 1 to keep the toilet seat paper 6 securely attached by suction to the toilet seat 1. After the use, the toilet seat paper 6 is removed from the toilet seat 1 paper 6 and thrown into the toilet bowl or a trash box by the user's hand. The air suction device 13 of this embodiment 1 is suitably disposed outside of the toilet bowl main body 3, but it may be suitably arranged inside of the toilet bowl main body 3.

Embodiment 2

[0055] In the above-described Embodiment 2, the description has been made as to an example in which the toilet seat 1 is of the single piece structure, the description of the embodiment 2 will now be made in terms of the toilet seat 1 that has a double layer structure including an upper layer 101 and a lower layer 103 on the basis of FIGS. 5 to 7. FIG. 5 is a perspective view showing an outer appearance of the toilet seat assembled together with the toilet cover, FIG. 6 is an exploded perspective view of the toilet cover and the paper cassette contained within the toilet cover, and FIG. 7

is a perspective view of the toilet bowl in the state ready for use, the same reference numerals used in FIGS. 1 to 4 of the embodiment 1 designate the same or identical components.

[0056] The toilet seat 1 is arranged in the double layer structure including the upper and the lower layers in order to make sure that, since the lower layer toilet seat 102 which corresponds to the toilet seat 1 of a single layer structure is made of a hard resin in order to withstand the weight of the user and it causes the user to feel coldness when the users skin touches it and feels discomfort, the user does not feel coldness even when the user's skin directly touches it. Therefore, the upper layer of the toilet seat 101 is preferably made of a thermally insulating material such as urethane.

[0057] In the toilet seat of the upper and lower double layer structure, the air suction holes 11 and the air suction passage 120 and the like explained in embodiment 1 are naturally provided in the upper layer toilet seat 101 made of a thermally insulating material. Their arrangements are substantially similar to those of embodiment 1, so that their explanations are omitted.

Embodiment 3

[0058] In embodiment 3, a toilet seat paper 60 which is an improvement of the toilet seat paper 6 of embodiments 1 and 2 will now be described on the basis of FIG. 8. FIG. 8 is a plan view.

[0059] In FIG. 8, the reference numeral 60 is the toilet seat paper placed on the seat surface of the toilet seat to cover it, and it is shaped into an annular shape which follows an eclipse having a major axis extending in the horizontal direction in FIG. 8. The right hand direction of the major axis is the front direction of the user and the left hand direction of the major axis is the back side of the user.

[0060] The reference numeral 62 is a projection portion formed to extend outwardly at a portion of an outer periphery of the toilet seat paper 60 and is projected to have an surface area that can be at lease picked by finger tips. Although the illustrated projection portion 2 is formed to have a substantially U-shaped outer periphery; another suitable configuration, such as square or triangular shape may also be used.

[0061] It is preferable that the illustrated projection portion 62 is provided at the front side of the user on the above mentioned major axis in the seated position, this is not limiting and may be at any portion of the outer periphery of the toilet seat paper 60 and it is preferable to provide it at the position between the user's legs.

[0062] Thus, the projection portion 62 is provided in the toilet seat paper 60, so that the projection portion 62 can be picked to be easily separated from the toilet seat.

[0063] Also, the projection portion 62 may be provided to position between the user's legs, and particularly on the major axis, so that the toilet seat paper can be easily picked by the user while the user remains seated on the toilet seat, enabling to prevent the toilet seat paper from sticking to the skin of the rising user.

[0064] Also, the toilet seat paper 60 can be separated from one end of the major axis of the generally eclipse toilet seat paper 60 formed according to the toilet seat configuration, that is, the toilet seat paper 60 having the major axis at its

center can be separated along the central major axis, so that the symmetrical toilet seat paper can be easily removed from the toilet seat without breaking it.

[0065] Also, in the forgoing embodiments 1 and 2, by using this toilet seat paper 60, a toilet seat paper and a toilet seat paper setting device having an advantageous result of easy handling by the user can be obtained in addition to the advantages of embodiments 1 and 2.

[0066] The toilet seat paper 6 or 60 may preferably be made of a water soluble material, so that the toilet seat paper can be thrown away into the toilet bowl. Also, the toilet seat paper may have an aroma constituent impregnated therein, so that bad smell can be suppressed and relieve oneself in comfort in an aromatic atmosphere.

Embodiment 4

[0067] Although, in the above embodiment 3, the projection portion 62 is formed as a one continuous portion of the toilet seat paper 60, the projection portion 62 in the embodiment 4 illustrated in FIG. 9 is made as a piece separate piece and attached to the main body of the toilet seat paper 60, whereby the toilet seat paper 60 having the projection portion 62 similar to that in the embodiment 3 is formed.

[0068] In embodiment 3, when the toilet seat paper 60 having a continuously formed projection portion 62 is cut from a blank paper sheet, the yield is lowered due to the existence of the projection portion 62, but in this embodiment 4, since the projection portion 62 is formed as a separate member and the annular toilet seat paper 60 without projection portion 62 can be cut from the blank, the manufacturing yield in the can be improved and, moreover, the strength of the attached portion is increased, further suppressing the breakage of the paper at the time of separation because the separate projection portion 62 is attached to the annular toilet seat paper 60.

INDUSTRIAL APPLICABILITY

[0069] This invention can be applied not only to a domestic western style toilet, but also to a western style toilet for a business usage for a highly hygienic public usage in hotels, for example.

BRIEF DESCRIPTION OF THE DRAWINGS

[0070] FIG. 1 is a perspective view of an outer appearance of a toilet seat arranged assembled together with a toilet cover. (Embodiment 1)

[0071] FIG. 2 is an exploded perspective view of the toilet seat and a paper cassette contained within the toilet cover. (Embodiment 1)

[0072] FIG. 3 is a perspective view of an outer appearance of the toilet in the used state. (Embodiment 1)

[0073] FIG. 4 is a sectional view of the toilet seat. (Embodiment 1)

[0074] FIG. 5 is a perspective view showing an outer appearance of the toilet seat assembled together with the toilet cover. (Embodiment 2)

[0075] FIG. 6 is an exploded perspective view of the toilet cover and the paper cassette contained within the toilet cover. (Embodiment 2)

[0076] FIG. 7 is a perspective view of the toilet bowl in the state ready for use. (Embodiment 2)

[0077] FIG. 8 is a plan view of the toilet seat paper (Embodiment 3).

[0078] FIG. 9 is a plan view of the toilet seat paper (Embodiment 4).

[0079] Explanation Of Reference Numerals

[0080] 1 toilet seat

[0081] 2 toilet cover

[0082] 3 toilet bowl main body

[0083] 5 elastic member

[0084] 5 paper cassette

[0085] 11 air passage (fine holes)

[0086] 12 air suction passage

[0087] 13 air suction device

[0088] 14 air suction means

[0089] 51 container portion

[0090] 52 opening

[0091] 53 paper passage frame member

[0092] 54 elastic member

[0093] 6 toilet seat paper (stack)

[0094] 60 toilet seat paper

[0095] 62 projection portion

1. A toilet seat paper setting device comprising:

a toilet cover including a paper cassette in which a plurality of toilet seat papers, which are to be placed to cover a seat surface of a toilet seat, are contained in stacked layers, separable one-by-one into separate paper sheets;

a plurality of air suction holes disposed in the toilet seat and opening in the seat surface of the toilet seat;

air suction means for evacuating air through the suction holes, wherein a paper sheet in the paper cassette is attached by suction to the toilet seat by action of the air suction means when the toilet cover is placed on the toilet seat;

a sensor for detecting a user's entry into a region near the toilet seat and generating an entry signal in response, and detecting the user's exit from the region and generating an exit signal in response and

control means for activating the air suction means based on an entry signal from the sensor and deactivating the air suction means based on an exit signal from the sensor.

2. The toilet seat paper setting device as claimed in claim 1, wherein the toilet seat comprises an upper member and a lower member and the toilet seat with the air suction holes comprises the upper member.

3. The toilet seat paper setting device as claimed in claim 1, wherein the toilet seat provided with the air suction holes is coaxially hinged with the toilet cover.

4. The toilet seat paper setting device as claimed in claim 1, wherein the toilet seat with the air suction holes is a thermally insulating material.

5. The toilet seat paper setting device as claimed in claim 1, wherein the air suction holes that open in the seat surface of the toilet seat are fine holes difficult to recognize with a naked eye.

6. The toilet seat paper setting device as claimed in claim 1, wherein the air suction means comprises an air suction device disposed inside or outside of a toilet main body, and an air suction passage disposed within the toilet seat providing communication between the air suction device and the air suction holes.

7. (canceled)

8. The toilet seat paper setting device as claimed in claim 1, wherein the paper cassette comprises a container containing the toilet seat papers stacked in layers, a paper passing frame member having an opening for passage of the toilet seat papers therethrough, one-by-one, and detachably fitted to the container, and an elastic member disposed between the toilet papers stacked in layers and the container for urging the toilet seat papers against the paper passing frame member.

9. A method for setting a toilet seat paper using a toilet seat paper setting device comprising a toilet cover including a paper cassette in which a plurality of toilet seat papers, which are to be placed to cover a seat surface of a toilet seat, are contained in stacked layers, separable one-by-one into separate paper sheets, a plurality of air suction holes disposed in the toilet seat and opening in the seat surface of the toilet seat, air suction means for evacuating air through the suction holes, a sensor for detecting a user's entry into and exit from a region near the toilet seat, and control means for activating the air suction means based on an entry signal from the sensor and deactivating the air suction means based on an exit signal from the sensor, said method comprising:

activating the air suction means with the control means after reception of an entry signal from the sensor and until reception of an exit signal from the sensor, and

upon openings the toilet seat, separating from the stacked toilet papers within the paper cassette only the toilet seat paper attached to the toilet seat, by evacuation of air through the suction holes when the toilet seat is closed.

10. The method for setting toilet seat paper as claimed in claim 9, including activating the air suction means at least while a user remains seated on the toilet seat to keep the toilet seat paper attached by suction to the toilet seat.

11. (canceled)

12. The toilet seat paper setting device as claimed in claim 1, wherein the toilet seat paper includes a projection extending outwardly and capable of being held by at least finger tips at an outer peripheral edge of the toilet seat paper.

13. The toilet seat paper setting device as claimed in claim 12, wherein the projection has a substantially U-shaped configuration.

14. The toilet seat paper setting device as claimed in claim 12, wherein the projection is provided to be positioned between user's legs when the user sits on the toilet seat.

15. The toilet seat paper setting device as claimed in claim 12, wherein the toilet seat paper is a water soluble material.

16. The toilet seat paper setting device as claimed in claim 12, wherein the toilet seat paper contains an aroma constituent therein.

17. The toilet seat paper setting device as claimed in claim 12, wherein the toilet seat paper has an annular shape.

18. The toilet seat paper setting device as claimed in claim 12, wherein the projection is one piece with the toilet seat paper.

19. The toilet seat paper setting device as claimed in **12**, wherein the projection is a separate piece attached to the toilet seat paper.

* * * * *