

(No Model.)

J. V. ROWLETT,
LAWN MOWER HANDLE.

No. 454,932.

Patented June 30, 1891.

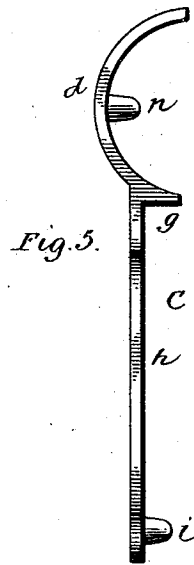
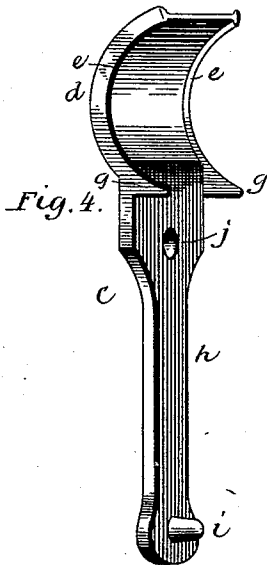
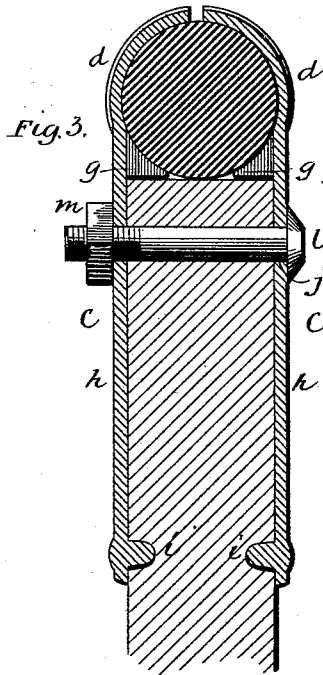
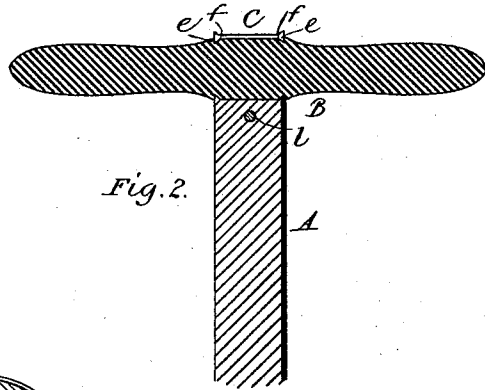
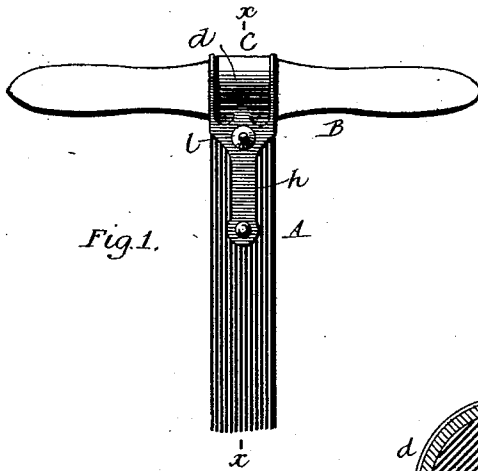

Witnesses:

Wm. H. Norton
Wm. H. Norton

Inventor:

Jacob V. Rowlett,
By *Wm. H. Norton*
his Attorney.

UNITED STATES PATENT OFFICE.

JACOB VORE ROWLETT, OF RICHMOND, INDIANA.

LAWN-MOWER HANDLE.

SPECIFICATION forming part of Letters Patent No. 454,932, dated June 30, 1891.

Application filed February 10, 1891. Serial No. 381,005. (No model.)

To all whom it may concern:

Be it known that I, JACOB VORE ROWLETT, a citizen of the United States, residing at Richmond, in the county of Wayne and State of Indiana, have invented certain new and useful Improvements in Lawn-Mower and other Handles; and I do hereby declare the following to be a full, clear, and exact description of the invention, such as will enable others skilled in the art to which it appertains to make and use the same.

My invention relates to a novel means for rigidly connecting together the handle and handle-bar, which are applied to and used in connection with a lawn-mower, or other analogous apparatus, the object being to provide a simple but effective construction which shall withstand all the effects due to the great strain which is received by handles of this character, the warping and consequent displacement of the handle caused by exposure to the weather, and the production of a fastening which shall be inexpensive in its manufacture and easy to apply.

To these ends my invention consists in the new and novel construction and application of a fastener, and in the construction of a handle-bar and handle to which such fastener is applied, all of which will be presently fully and clearly set forth in the following description, and especially pointed out in the claims.

In the accompanying drawings the same letters of reference indicate the same parts in all the figures.

Figure 1 of the drawings indicate in front elevation the upper portion of a handle-bar, a handle, and my improved fastener applied thereto. Fig. 2 is a central longitudinal section of the same. Fig. 3 is a section taken on the line *xx*, Fig. 1; and Fig. 4 is a perspective view of one of the parts of said fastener detached; Fig. 5, a view of a modified form.

Referring to the drawings, A indicates the upper portion of a handle-bar such as is used in connection with a lawn-mower.

B is the cross-bar constituting the handle proper, and C is the fastener connecting these parts together. The fastener C is formed of two parts or sections, preferably made of cast iron, the upper portion of each being curved inwardly, as shown, forming a clip *d*. On the inner side and at the edges of the clip are

ribs or beads *e*, which enter grooves *f*, of corresponding sizes made in the handle B. These ribs terminate at their lower ends in tongues or projections *g*, the under sides of the tongues forming a seat for the upper end of the handle-bar A. Extending downward from the clip *d* and cast integral therewith is a strap *h*, the lower portion being formed with a lug *i*, which enters a socket made therefor in the handle-bar, as shown, and in the upper portion is a hole *j*, which registers with the hole *k* in the bar A, and through which a bolt, such as *l*, is passed and secured in place by a nut. (Shown at *m*.) By reason of the lugs *i* I am enabled to secure a very tight and rigid connection of the parts by the employment of a single bolt and nut, the lugs serving the purpose of a screw or bolt connection. As seen in Fig. 3, the upper ends of the clips are slightly separated, in order that if any time the handle becomes loosened, the clips may be drawn together by tightening the bolt and the handle firmly secured thereby. By reason of the ribs *e* and grooves *f* the handle is held firmly against lateral movement, and this is attained without the necessity of using a mortise-and-tenon connection, which is the usual way employed and which is very unsatisfactory, in that the parts become much weakened and are liable to break from constant strain or to come apart after a lapse of time.

In Fig. 5 I have shown a slight modification of the means for holding the handle against lateral displacement. In this instance instead of employing ribs and grooves, as has heretofore been described, I form each section of the fastener with an inwardly-projecting boss *n*, which is adapted when the parts are connected to enter corresponding sockets made therefor in the handle, this construction answering the purpose quite as well as do the ribs and grooves.

By my invention I am enabled to produce at small cost a fastener for the handles of lawn-mowers or similar apparatus designed to be propelled by hand, which will hold the parts rigidly together and which can easily be applied.

It will be evident by my construction of fastener that it can be applied to purposes other than of securing the parts of a lawn-

mower or similar handles together, and I have shown it applied as above stated merely for the purpose of illustration.

I claim—

5 1. As a means for connecting the parts of a handle for lawn-mowers or similar apparatus, the combination, with a handle proper and with the handle-bar, as described, of a clip formed in two parts and comprised of
10 curved portions which partly surround the handle, straps which are connected to the handle-bar, and projections on said curved portions adapted to enter recesses in the handle for preventing the lateral displacement
15 thereof.

2. The combination, with a handle having the grooves, as described, and with a handle-bar, of a clip formed of two parts, each of which
20 consists of a curved portion having on its inner side the ribs adapted to enter the said

grooves, and of the strap integral with said curved portion and connected to the handle-bar, substantially as set forth.

3. The combination, with a handle having the grooves, as described, and with a handle-
25 bar, of a clip formed of two parts, each of which consists of a curved portion having on its inner side the rib adapted to enter the said grooves, and of the strap formed integral with
30 said curved portion and having the lug thereon adapted to enter the socket in the handle-bar and to be connected with said bar by means of a bolt, substantially as and for the purposes set forth.

In testimony whereof I affix my signature in
35 presence of two witnesses.

JACOB VORE ROWLETT.

Witnesses:

REUBEN MYRICK,
CHAS. R. DU HADWAY.