

(19) World Intellectual Property Organization
International Bureau



(43) International Publication Date
23 August 2007 (23.08.2007)

PCT

(10) International Publication Number
WO 2007/094116 A1

- (51) International Patent Classification:
B60R 21/34 (2006.01)
- (21) International Application Number:
PCT/JP2006/324309
- (22) International Filing Date:
29 November 2006 (29.11.2006)
- (25) Filing Language: English
- (26) Publication Language: English
- (30) Priority Data:
2006-016323 25 January 2006 (25.01.2006) JP
- (71) Applicants (for all designated States except US):
TAKATA CORPORATION [JP/JP]; 4-30, Roppongi
1-chome, Minato-ku, Tokyo, 1068510 (JP). TOYOTA JI-
DOSHA KABUSHIKI KAISHA [JP/JP]; 1, Toyota-cho,
Toyota-shi, Aichi, 4718571 (JP).

4-30, Roppongi 1-chome, Minato-ku, Tokyo, 1068510 (JP). TAKAHASHI, Hiroyuki [JP/JP]; c/o TOYOTA JIDOSHA KABUSHIKI KAISHA, 1, Toyota-cho, Toyota-shi, Aichi, 4718571 (JP).

(74) Agent: SHIGENO, Tsuyoshi; Nissin bldg. 9th floor, 5-10, Shinjuku 2-chome, Shinjuku-ku, Tokyo 1600022 (JP).

(81) Designated States (unless otherwise indicated, for every kind of national protection available): AE, AG, AL, AM, AT, AU, AZ, BA, BB, BG, BR, BW, BY, BZ, CA, CH, CN, CO, CR, CU, CZ, DE, DK, DM, DZ, EC, EE, EG, ES, FI, GB, GD, GE, GH, GM, GT, HN, HR, HU, ID, IL, IN, IS, KE, KG, KM, KN, KP, KR, KZ, LA, LC, LK, LR, LS, LT, LU, LV, LY, MA, MD, MG, MK, MN, MW, MX, MY, MZ, NA, NG, NI, NO, NZ, OM, PG, PH, PL, PT, RO, RS, RU, SC, SD, SE, SG, SK, SL, SM, SV, SY, TJ, TM, TN, TR, TT, TZ, UA, UG, US, UZ, VC, VN, ZA, ZM, ZW.

- (72) Inventors; and
- (75) Inventors/Applicants (for US only): TAKIMOTO, Takayuki [JP/JP]; c/o TAKATA CORPORATION,

(84) Designated States (unless otherwise indicated, for every kind of regional protection available): ARIPO (BW, GH, GM, KE, LS, MW, MZ, NA, SD, SL, SZ, TZ, UG, ZM,

[Continued on next page]

(54) Title: AIRBAG APPARATUS

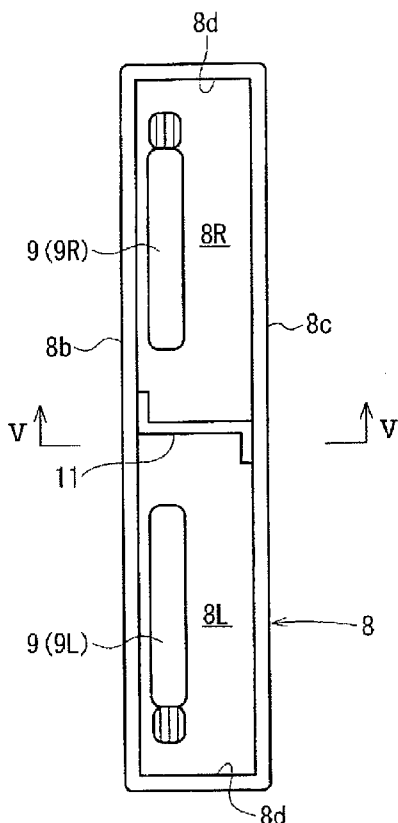

(57) Abstract: An airbag apparatus 4 for pedestrian protection capable of preventing or suppressing deformation of a case in a width-expanding direction when an airbag is expanded, by means of a simple countermeasure, is provided with a case 8 for housing a folded airbag 5, an inflator 9 for expanding the airbag 5, a lid 10 that closes an opening 3a of a hood 3 for passing an airbag 5, and so forth. In the middle of the case 8 in a longitudinal direction, a tie plate 11 serving as a connecting member connecting a front wall portion 8b and a rear wall portion 8c is provided.

WO 2007/094116 A1



ZW), Eurasian (AM, AZ, BY, KG, KZ, MD, RU, TJ, TM),
European (AT, BE, BG, CH, CY, CZ, DE, DK, EE, ES, FI,
FR, GB, GR, HU, IE, IS, IT, LT, LU, LV, MC, NL, PL, PT,
RO, SE, SI, SK, TR), OAPI (BF, BJ, CF, CG, CI, CM, GA,
GN, GQ, GW, ML, MR, NE, SN, TD, TG).

For two-letter codes and other abbreviations, refer to the "Guidance Notes on Codes and Abbreviations" appearing at the beginning of each regular issue of the PCT Gazette.

Published:

— *with international search report*

DESCRIPTION

AIRBAG APPARATUS

[Field of the Invention]

[0001]

The present invention relates to an airbag apparatus having an airbag that is extended along at least a part of a hood of a vehicle body.

[Background of the Invention]

[0002]

An airbag apparatus for pedestrian protection is known in which a pedestrian or the like (a body of a pedestrian or that of a motorcycle rider) is received by expanding an airbag along a portion in the vicinity of a cowl portion of a vehicle body. As an embodiment of the airbag apparatus for pedestrian protection, an airbag apparatus for pedestrian protection in which an airbag is housed in a case extending in a vehicle-body width direction is known (Japanese Unexamined Patent Application Publication No. 2005-280556).

[0003]

In an airbag apparatus for pedestrian protection, in which an airbag is housed in a case extending in a vehicle width direction, a force is applied to the case in a width-

expanding direction in a manner so as to separate a front wall portion and a rear wall portion of the case when the airbag is expanded. So as to oppose the force, a countermeasure to form the front wall portion and the rear wall portion of the case to have a thick wall, to form a rib, or the like is required.

[Summary of the Invention]

[0004]

It is an object of the present invention to provide an airbag apparatus capable of preventing or suppressing deformation of a case in a width-expanding direction when an airbag is expanded, by means of a simple countermeasure, in such an airbag apparatus for pedestrian protection in which an airbag is housed in the case extending in a vehicle-body width direction.

[0005]

The airbag apparatus in the present invention is characterized in that an airbag apparatus is provided with an airbag for expanding along at least a part of a hood of the vehicle body, a case that houses the airbag, and an inflator for expanding the airbag, and the case has a bottom portion, a front wall portion at a front side of the vehicle body, and a rear wall portion at a rear side of the vehicle body. The case further includes at least one connecting member that connects each of middle portions in a

longitudinal direction of the front wall portion and the rear wall portion of the case in the airbag apparatus extending in the vehicle-body width direction.

[Brief Description of the Drawings]

[0006]

[Fig. 1] Fig. 1 is a perspective view of an automobile provided with an airbag apparatus according to an embodiment.

[Fig. 2] Fig. 2 is a perspective view of the automobile of Fig. 1 when an airbag is expanded.

[Fig. 3] Fig. 3 is an enlarged cross-sectional view along a line III-III of Fig. 1.

[Fig. 4] Fig. 4 is a view from a direction indicated by arrows IV-IV of Fig. 3.

[Fig. 5] Fig. 5 is a cross-sectional view along a line V-V of Fig. 4.

[Fig. 6] Fig. 6 is a cross-sectional perspective view of the same part as that of Fig. 5.

[Fig. 7] Fig. 7 is a cross-section of a case showing another embodiment.

[Fig. 8] Fig. 8 is a cross-sectional perspective view of the case showing the another embodiment.

[Fig. 9] Fig. 9 is a perspective view of the automobile when the airbag is expanded.

[Detailed Explanation of the Preferred Embodiment]

[0007]

An airbag apparatus of the present invention is provided with an airbag for being expanded along at least a part of a hood of a vehicle body, a case for housing the airbag, and an inflator for expanding the airbag. The case extends in a vehicle-body width direction. The case is provided with a bottom portion, a front wall portion at a front side of the vehicle body, a rear wall portion at a rear side of the vehicle body, and a connecting member that connects each of middle portions in a longitudinal direction of the front wall portion and the rear wall portion.

[0008]

In the airbag apparatus according to the present invention, the middle portions of the front wall portion and the rear wall portion of the case in the longitudinal direction are connected by the connecting member. Accordingly, deformation of the front wall portion and the rear wall portion is prevented or suppressed even when the front wall portion and the rear wall portion are pressed by the airbag in a separating direction when the airbag is expanded.

[0009]

Although only one connecting member may be provided in the middle of the case in the longitudinal direction, a plurality of connecting members may be provided in a manner so as to have disposing positions different to each other in

the longitudinal direction of the case, and when in such a configuration, a reinforcing effect of the case becomes high.
[0010]

In the present invention, in a case that an inside of the case is partitioned into a plurality of chambers by the connecting member, the airbag may be individually disposed in each of the chambers, or the airbag may be continuously disposed across the chambers in a manner so as to allow the airbag to pass over an upper side of the connecting member.
[0011]

Hereinafter, an embodiment will be explained referring to the drawings. Fig. 1 is a perspective view of an automobile provided with an airbag apparatus according to the embodiment, Fig. 2 is a perspective view of the automobile of Fig. 1 when the airbag is expanded, Fig. 3 is an enlarged cross-sectional view along a line III-III of Fig. 1, Fig. 4 is a view from a direction indicated by arrows IV-IV of Fig. 3 (though illustration of the airbag is omitted), Fig. 5 is a cross-sectional view along a line V-V of Fig. 4, and Fig. 6 is a cross-sectional perspective view of the same part as that of Fig. 5.

[0012]

As shown in Fig. 1, the present invention is not limited to a specific motor vehicle configuration although an automobile 1 is a four-door sedan in this embodiment. An

airbag apparatus 4 for protecting pedestrians, motorcycle riders and so forth is installed at a rear portion of a hood 3. As shown in Fig. 2, a cowl louver 2, a windshield 6 and at least parts of left and right A-pillars 7 are covered with an airbag 5 (5L and 5R) of the airbag apparatus 4 when the airbag 5 (5L and 5R) is expanded.

[0013]

As shown in Fig. 3 through Fig. 6, the airbag apparatus 4 is provided with a case 8 for housing the folded airbag 5 (5L and 5R), inflators 9 (9L and 9R) for expanding the airbag 5 (5L and 5R), a lid 10 closing an opening 3a of the hood 3, for passing the airbag 5 (5L and 5R) and so forth.

[0014]

The case 8 has a long box-shape extending in the vehicle-body width direction. The case 8 includes a bottom portion 8a, a front wall portion 8b, a rear wall portion 8c and a left and right end walls 8d and 8d. An upper side of the case 8 is open.

[0015]

In this embodiment, a tie plate 11 as a connecting member that connects the front wall portion 8b and the rear wall portion 8c is provided in the middle of the case 8 in a longitudinal direction.

[0016]

The tie plate 11 is configured such that each of edges

at a front wall portion 8b side and a rear wall portion 8c side is bent into L-shape. Each of the edges is firmly fixed to the front wall portion 8b and the rear wall portion 8c with welding or the like. However, a connecting structure of the tie plate 11 to the front wall portion 8b and the rear wall portion 8c is not limited thereto.

[0017]

The tie plate 11 has a height reaching up to an upper edge of each of the front wall portion 8b and the rear wall portion 8c from the bottom portion 8a of the case 8.

[0018]

An inside of the case 8 is partitioned into two chambers 8L and 8R at a left side and right side of the vehicle body, respectively by the tie plate 11. Accordingly, airbags 5L and 5R and inflators 9L and 9R are disposed in each of the chambers 8L and 8R in this embodiment. The airbags 5L and 5R are formed of separate bodies, and are independent from each other. The airbags 5L and 5R are firmly fixed to the case 8.

[0019]

Although an illustration is omitted, the inflators 9L and 9R may be disposed outside of the case 8, and gas may be introduced into the airbags 5L and 5R by a gas-distribution member such as a duct or the like.

[0020]

As shown in Fig. 5 or the like, in this embodiment, cutout portions (the sign is omitted) are formed at both ends of a lower side portion of the tie plate 11 (portions respectively facing a corner portion between the front wall portion 8b and the bottom portion 8a, and a corner portion between the rear end portion 8c and the bottom portion 8a of the case 8). Furthermore, gaps exist between the tie plate 11 and each of the corner portions, respectively. The cutout portion is formed for simplifying formation of the tie plate 11, and is utilized as an insertion opening for a harness (an illustration is omitted) of each of the inflators 9L and 9R or the like, or as a drain outlet from each of the chambers 8L and 8R or the like.

[0021]

The lid 10 is configured such that a rear edge thereof is fastened to the vehicle body via a hinge (not shown) at a rear edge of the opening 3a, and is configured to open out while rotating about the hinge rearward as indicated by an arrow θ in Fig. 3 when the airbag 5 (5L and 5R) is expanded. A front edge of the lid 10 is fastened to the vehicle body at a front edge of the opening 3a by means of a latch member (not shown) such as a clip or the like. The latch member is constructed to release a latching operation when the lid 10 is opened by being pressed by the airbag 5 (5L and 5R).

[0022]

In a case that a pedestrian, a motorcycle rider, or the like collides with an automobile provided with the airbag apparatus 4 having such a construction, the inflator 9 is activated on the basis of a detection signal of a human body collision detection sensor (not shown), and the airbag 5 (5L and 5R) starts to be expanded by the blowing-out gas thereof. The lid 10 is opened by being pressed by the expanding airbag 5 (5L and 5R), and the airbag 5 (5L and 5R) is developed along an outer surface of the vehicle body as shown in Fig. 2.

[0023]

When the airbag 5 (5L and 5R) is expanded, the front wall portion 8b and the rear wall portion 8c of the case 8 are pressed in a direction away from each other by the airbag 5 (5L and 5R). However, an expanding-out operation of the front wall portion 8b and the rear wall portion 8c is suppressed since the front wall portion 8b and the rear wall portion 8c are connected by the tie plate 11 in this embodiment. Furthermore, the airbag 5 (5L and 5R) is expanded upward, and is developed as shown in Fig. 2 while passing through the opening 3a.

[0024]

In the embodiments in Fig. 1 through Fig. 6, the tie plate 11 is configured to have the height reaching up to the upper edges of the front wall portion 8b and the rear wall

portion 8c, and the inside of the case 8 is partitioned into two chambers 8L and 8R. Accordingly, two of the airbags 5L and 5R are individually installed in each of the chambers 8L and 8R.

[0025]

Fig. 7 is a cross-sectional view of a case of an airbag apparatus according to another embodiment, Fig. 8 is a cross-sectional perspective view of the case, and Fig. 9 is a perspective view of an automobile when an airbag is expanded.

[0026]

In the embodiment in Fig. 7 through Fig. 9, a tie plate 12 is configured to have a height in an extent of substantially half that of the front wall portion 8b and the rear wall portion 8c, and the folded airbag 13 is disposed at an upper side of the tie plate 12. The airbag 13 is continuously provided across the chambers 8L and 8R at both the left and right sides of the tie plate 12 passing over the upper side of the tie plate 12.

[0027]

Accordingly, the airbag 13 is continuously expanded and developed in an integral manner from the left side to the right side of the vehicle body, as shown in Fig. 9.

[0028]

Two of the inflators 9L and 9R are respectively

disposed in each of the chambers 8L and 8R since the airbag 13 is extending in a left and right direction of the vehicle body to have a long shape. However, one inflator having gas-blowing outlets at both end sides in a longitudinal direction may be disposed across both of the chambers 8L and 8R. Furthermore, it is applicable to have a construction in which the gas is introduced into the airbag in each of the chambers 8L and 8R from the inflator disposed outside the case 8 via a duct.

[0029]

Any of the aforementioned embodiments is an example of the present invention, and the present invention can take an embodiment other than that shown in the drawings.

[0030]

For example, a connecting member other than the tie plate may be used. The connecting member may be that connecting only each of the upper edges of the front wall portion 8b and the rear wall portion 8c. Furthermore, two or more connecting members may be provided while being spaced apart in the vehicle-body width direction.

[0031]

Although the present invention is explained in detail using a specific configuration, it is apparent for those skilled in the art that various modifications can be made without departing from intention and an area of the present

invention.

The present application contains subject matter related to Japanese Patent Application (Japanese Unexamined Patent Application Publication No. 2006-016323) filed in the Japanese Patent Office on January 25th, 2006, the entire contents of which are incorporated herein by reference.

CLAIMS

[1] An airbag apparatus for pedestrian protection comprising:

an airbag for expanding along at least a part of a hood of a vehicle body; a case housing the airbag; and an inflator for expanding the airbag,

wherein the case comprises a bottom portion, a front wall portion at a front side of the vehicle body, and a rear wall portion at a rear side of the vehicle body, and

wherein the case further comprises at least one connecting member connecting each of middle portions in a longitudinal direction of the front wall portion and the rear wall portion of the case in the airbag apparatus extending in a vehicle-body width direction.

[2] The airbag apparatus according to Claim 1, wherein one connecting member is provided in the middle of the case in the longitudinal direction.

[3] The airbag apparatus according to Claim 1, wherein a plurality of connecting members are provided in a manner so as to have disposing positions different from each other in the longitudinal direction of the case.

[4] The airbag apparatus according to Claim 1, wherein an inside of the case is partitioned into a plurality of chambers by the connecting member.

[5] The airbag apparatus according to Claim 4, wherein the airbag is installed in each of the chambers in an independent manner.

[6] The airbag apparatus according to Claim 4, wherein the connecting member is provided to be positioned toward a lower side with respect to a middle portion in a height direction of the case, and the airbag is continuously disposed across each of the chambers passing over an upper side of the connecting member.

[7] The airbag apparatus according to Claim 6, wherein an inflator is disposed in each of the chambers.

[8] The airbag apparatus according to Claim 6, wherein one inflator having gas-blowing outlets at both ends in a longitudinal direction is installed across each of the chambers.

[9] The airbag apparatus according to Claim 1, wherein the connecting member is a tie plate.

Fig. 1

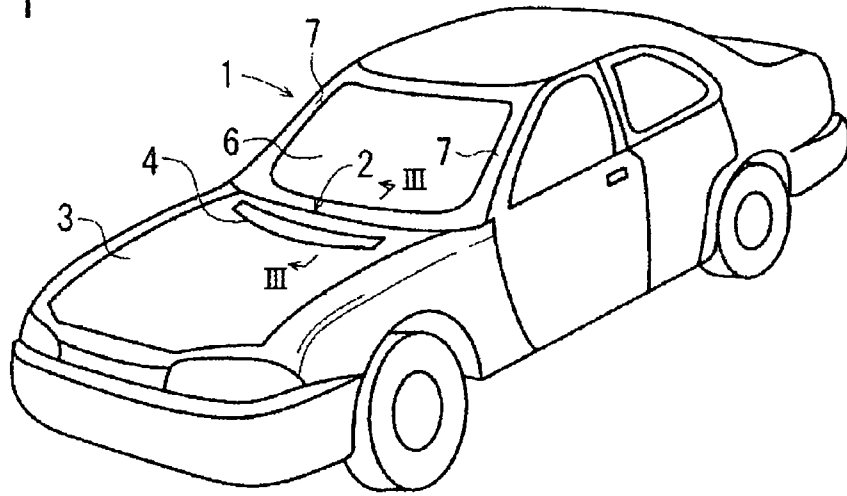

Fig. 2

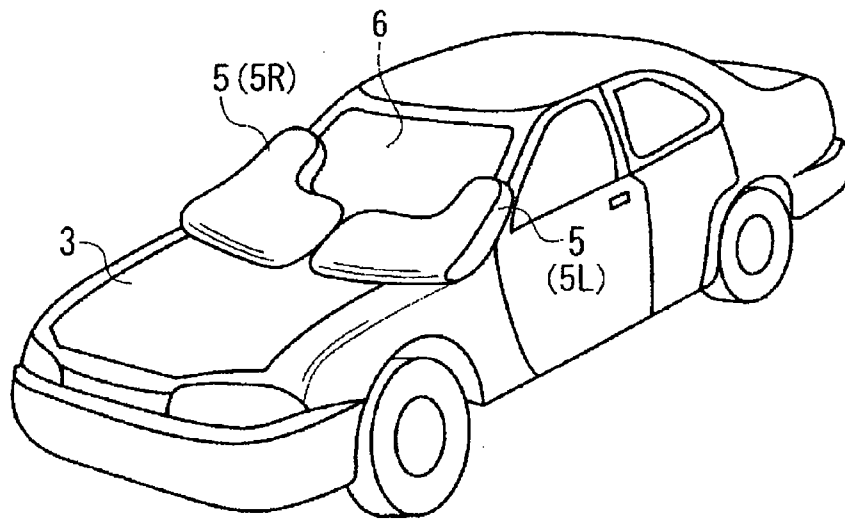

Fig. 3

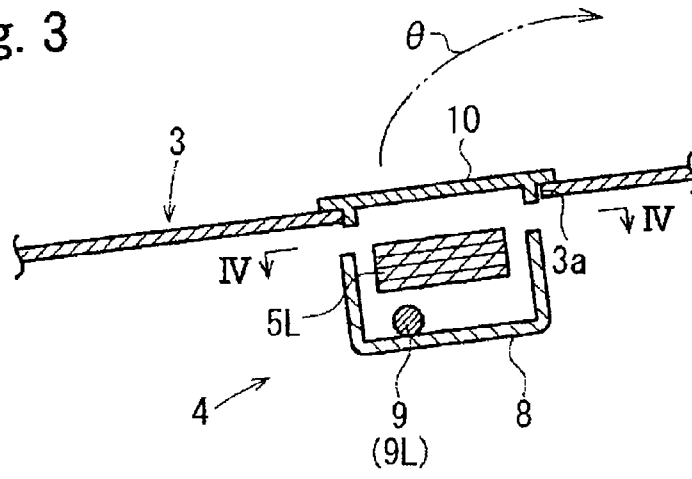

Fig. 4

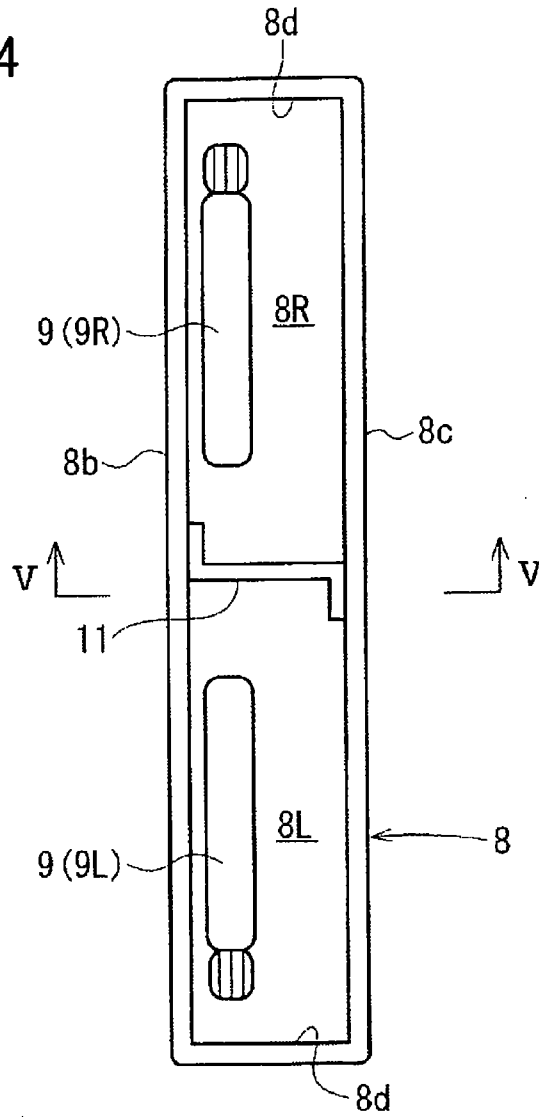

Fig. 5

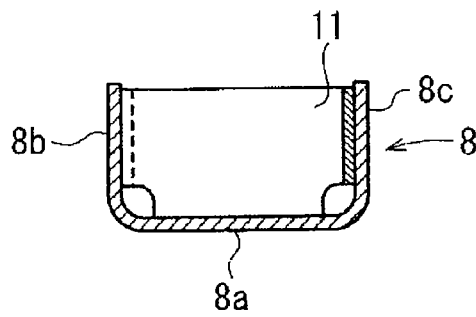

Fig. 6

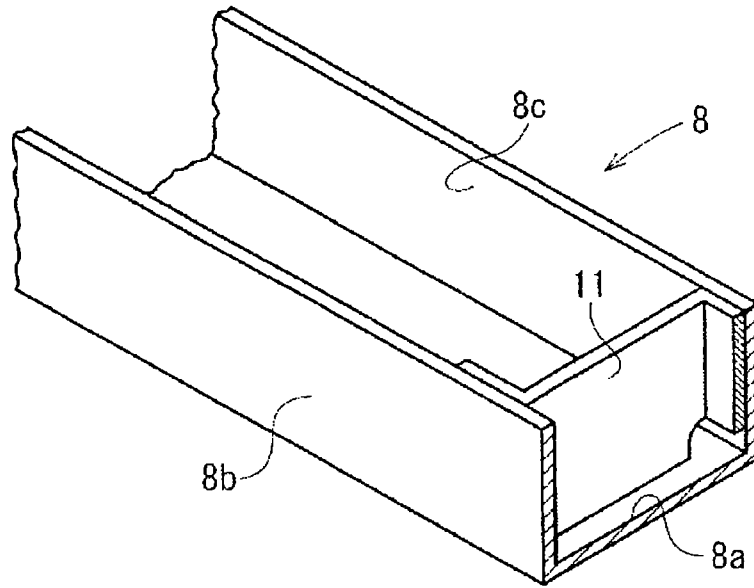

Fig. 7

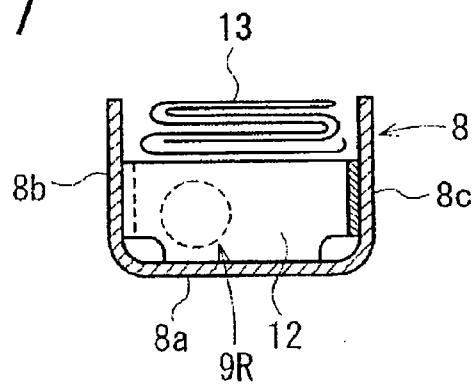

Fig. 8

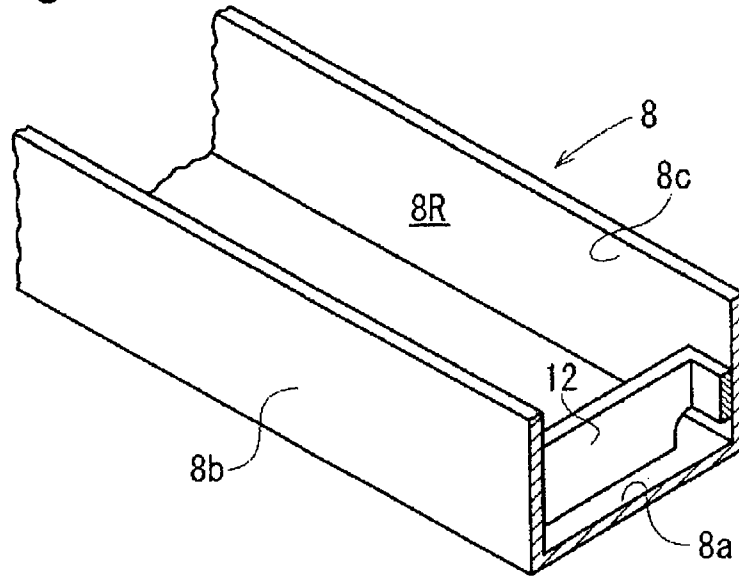
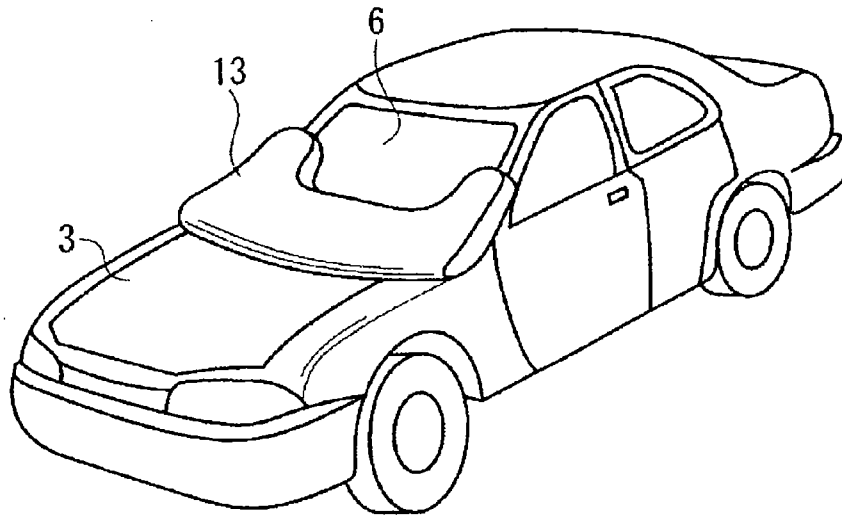

Fig. 9



INTERNATIONALSEARCHREPORT

International application No.

PCT/JP2006/324309

| A. CLASSIFICATION OF SUBJECT MATTER Int.Cl. B60R21/34 (2006.01) i According to International Patent Classification (IPC) or to both national classification and IPC | | |
|--|---|--|
| B. FIELDS SEARCHED Minimum documentation searched (classification system followed by classification symbols) Int.Cl. B60R21/00-21/34 Documentation searched other than minimum documentation to the extent that such documents are included in the fields searched Published examined utility model applications of Japan 1922-1996 Published unexamined utility model applications of Japan 1971-2007 Registered utility model specifications of Japan 1996-2007 Published registered utility model applications of Japan 1994-2007 Electronic data base consulted during the international search (name of data base and, where practicable, search terms used) | | |
| C. DOCUMENTS CONSIDERED TO BE RELEVANT | | |
| Category* | Citation of document, with indication, where appropriate, of the relevant passages | Relevant to claim No. |
| Y | JP 2005-280556 A (TOYODA GOSEI Co., Ltd.) 2005.10.13, Full text; all drawing & US 2005-205333 A1 | 1-9 |
| Y | JP 2001-277979 A (TOYODA GOSEI CO., LTD.) 2001.10.10, 【0024】, Fig.1,3 (Family: none) | 1-9 |
| A | JP 9-164906 A (KOSEI OTANI) 1997.06.24, Full Text; all drawing (Family: none) | 1 |
| A | JP 2003-291772 A (TAKATA Co., LTD.) 2003.10.15, Full text; all drawings & US 2003-234525 A1 & EP 1350691 A1 | 1 |
| <input checked="" type="checkbox"/> Further documents are listed in the continuation of Box C. <input type="checkbox"/> See patent family annex. | | |
| * Special categories of cited documents: "A" document defining the general state of the art which is not considered to be of particular relevance "E" earlier application or patent but published on or after the international filing date "L" document which may throw doubts on priority claim(s) or which is cited to establish the publication date of another citation or other special reason (as specified) "O" document referring to an oral disclosure, use, exhibition or other means "P" document published prior to the international filing date but later than the priority date claimed "T" later document published after the international filing date or priority date and not in conflict with the application but cited to understand the principle or theory underlying the invention "X" document of particular relevance; the claimed invention cannot be considered novel or cannot be considered to involve an inventive step when the document is taken alone "Y" document of particular relevance; the claimed invention cannot be considered to involve an inventive step when the document is combined with one or more other such documents, such combination being obvious to a person skilled in the art "&" document member of the same patent family | | |
| Date of the actual completion of the international search 02.03.2007 | | Date of mailing of the international search report 13.03.2007 |
| Name and mailing address of the ISA/JP Japan Patent Office 3-4-3, Kasumigaseki, Chiyoda-ku, Tokyo 100-8915, Japan | | Authorized officer Koji Nishimoto Telephone No. +81-3-3581-1101 Ext. 3381 |
| | | 3Q 9338 |

INTERNATIONALSEARCHREPORTInternational application No.
PCT/JP2006/324309

| C (Continuation). DOCUMENTS CONSIDERED TO BE RELEVANT | | |
|---|---|-----------------------|
| Category* | Citation of document, with indication, where appropriate, of the relevant passages | Relevant to claim No. |
| A | JP 2003-291756 A (TAKATA Co., LTD.) 2003.10.15, Full text; all drawings (Family; none) | 1 |