



US012022783B2

(12) **United States Patent**
Ellsworth

(10) **Patent No.:** **US 12,022,783 B2**

(45) **Date of Patent:** **Jul. 2, 2024**

(54) **MODULAR HYDROPONIC GROWING APPARATUS AND SYSTEM**

(71) Applicant: **Cecil Logan Ellsworth**, Wasilla, AK (US)

(72) Inventor: **Cecil Logan Ellsworth**, Wasilla, AK (US)

(*) Notice: Subject to any disclaimer, the term of this patent is extended or adjusted under 35 U.S.C. 154(b) by 324 days.

(21) Appl. No.: **17/681,269**

(22) Filed: **Feb. 25, 2022**

(65) **Prior Publication Data**

US 2022/0272918 A1 Sep. 1, 2022

Related U.S. Application Data

(63) Continuation of application No. 16/504,880, filed on Jul. 8, 2019, now Pat. No. 11,284,573.

(51) **Int. Cl.**
A01G 31/06 (2006.01)
A01G 31/02 (2006.01)
A01G 31/00 (2018.01)

(52) **U.S. Cl.**
CPC *A01G 31/06* (2013.01); *A01G 31/02* (2013.01); *A01G 2031/006* (2013.01)

(58) **Field of Classification Search**

CPC *A01G 31/00*; *A01G 31/0206*; *A01G 2031/006*; *A01G 9/02*; *A01G 9/022*; *A01G 9/024*; *A01G 9/025*
See application file for complete search history.

(56) **References Cited**

U.S. PATENT DOCUMENTS

4,231,189 A *	11/1980	Hochberg	<i>A01G 9/02</i> 47/83
4,536,988 A	8/1985	Hogen		
2006/0150485 A1	7/2006	Somerville		
2012/0324787 A1	12/2012	Daas		
2017/0027119 A1	2/2017	Storey		
2017/0347534 A1 *	12/2017	Weisel	<i>A01G 9/02</i>
2019/0269080 A1 *	9/2019	Whitworth	<i>A01G 31/06</i>
2020/0100435 A1 *	4/2020	Gebes	<i>A01G 9/02</i>
2020/0352122 A1	11/2020	Matera		

* cited by examiner

Primary Examiner — Monica L Perry

Assistant Examiner — Henry Hooper Mudd

(57) **ABSTRACT**

The present invention provides various modular hydroponic growing apparatuses, each having oppositely positioned slats or other compatible surfaces between which is defined an expandable growth channel, wherein at least one of the slats or other compatible surfaces are biased inwardly towards the opposing slat or other compatible surface via a biasing element.

18 Claims, 4 Drawing Sheets

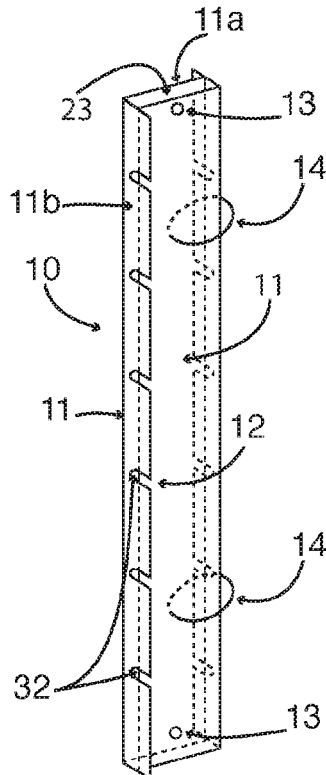

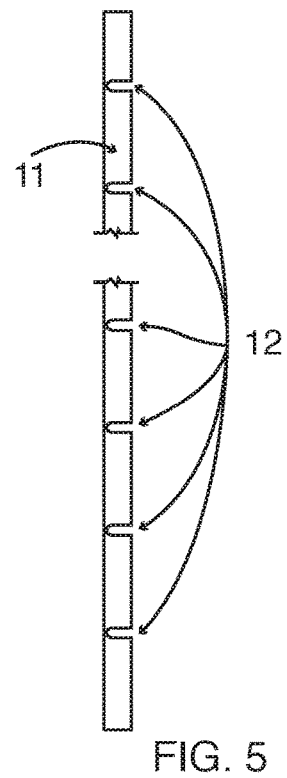
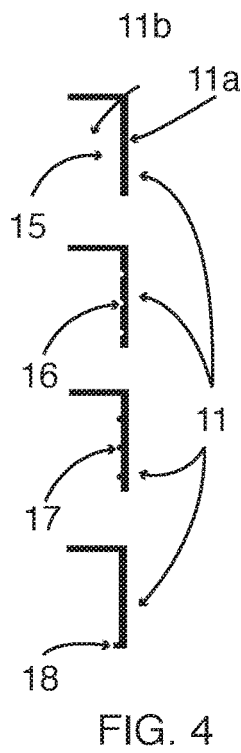
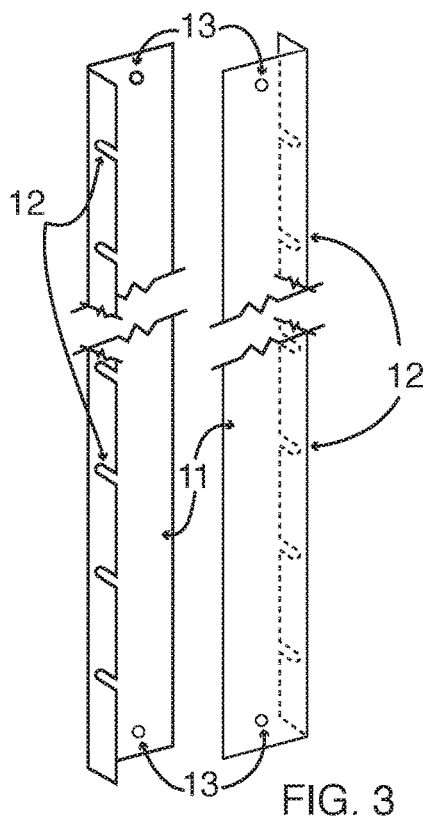
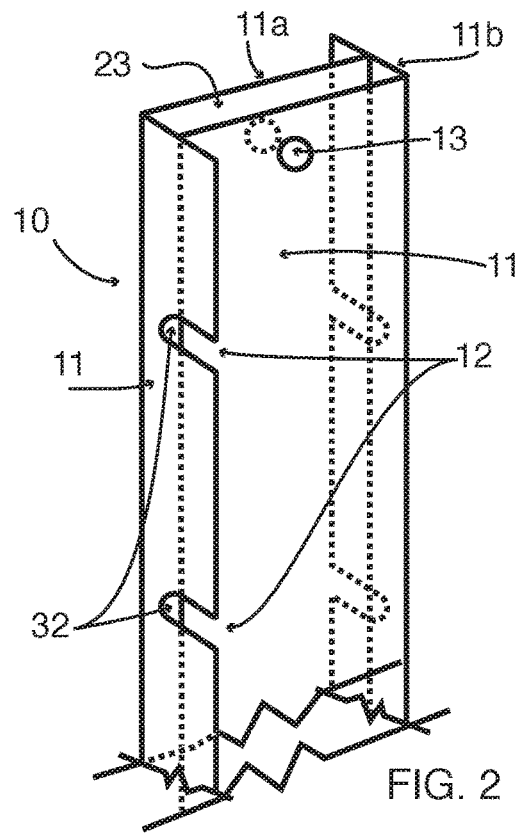
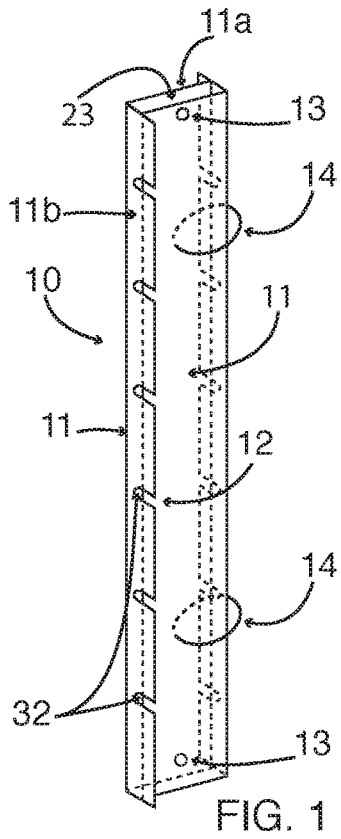

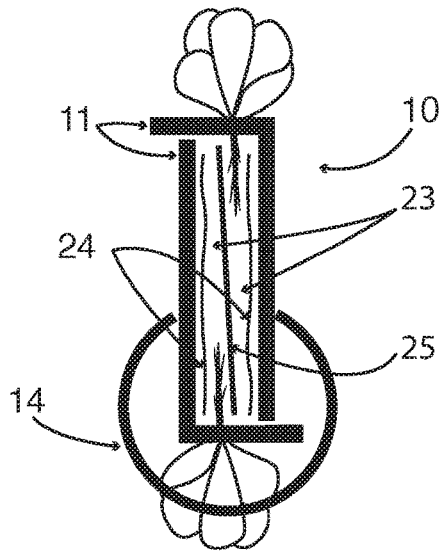

FIG. 6

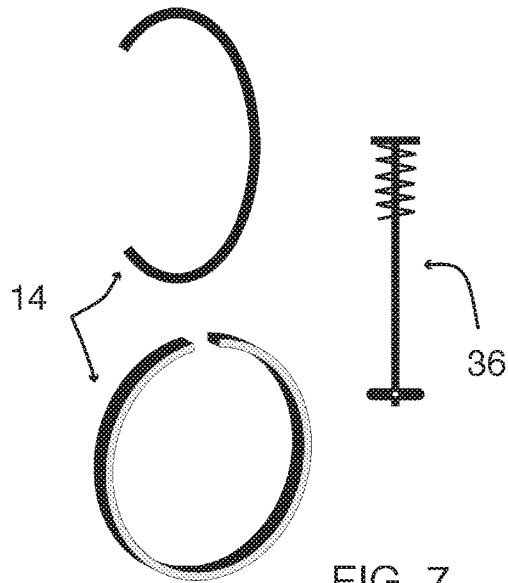

FIG. 7

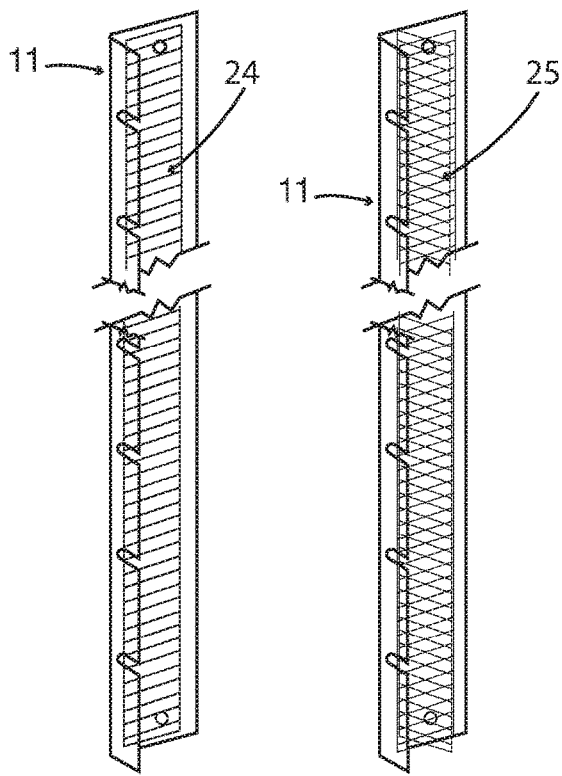

FIG. 8

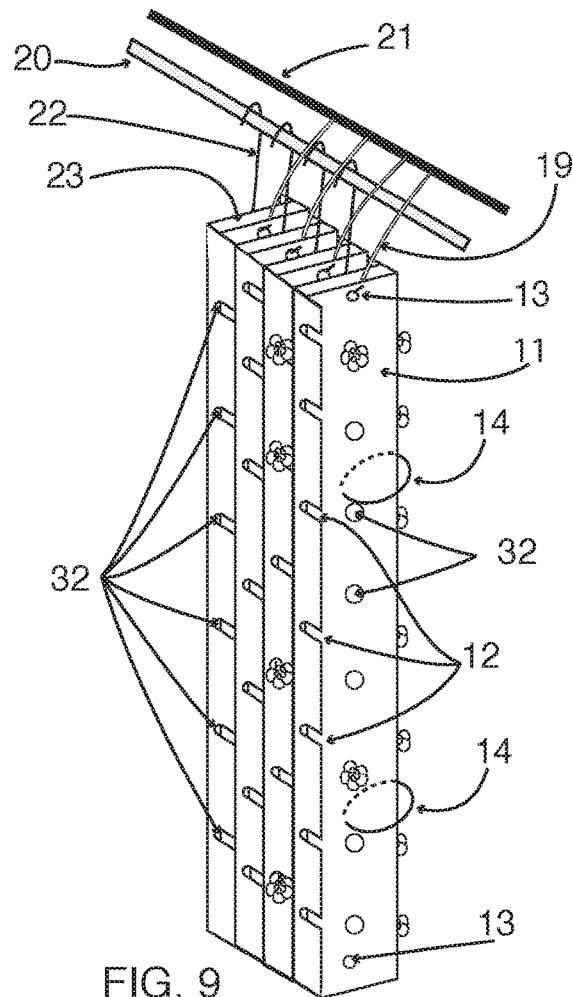

FIG. 9

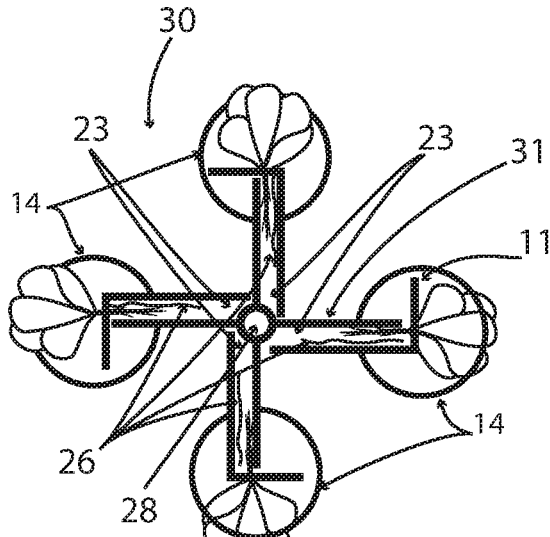

FIG. 10

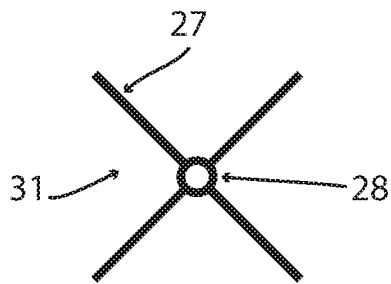

FIG. 11

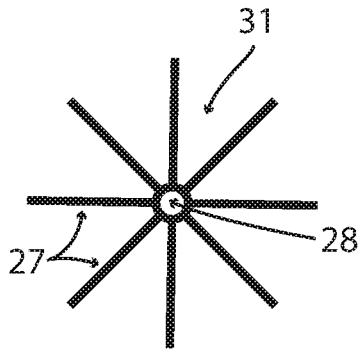

FIG. 12

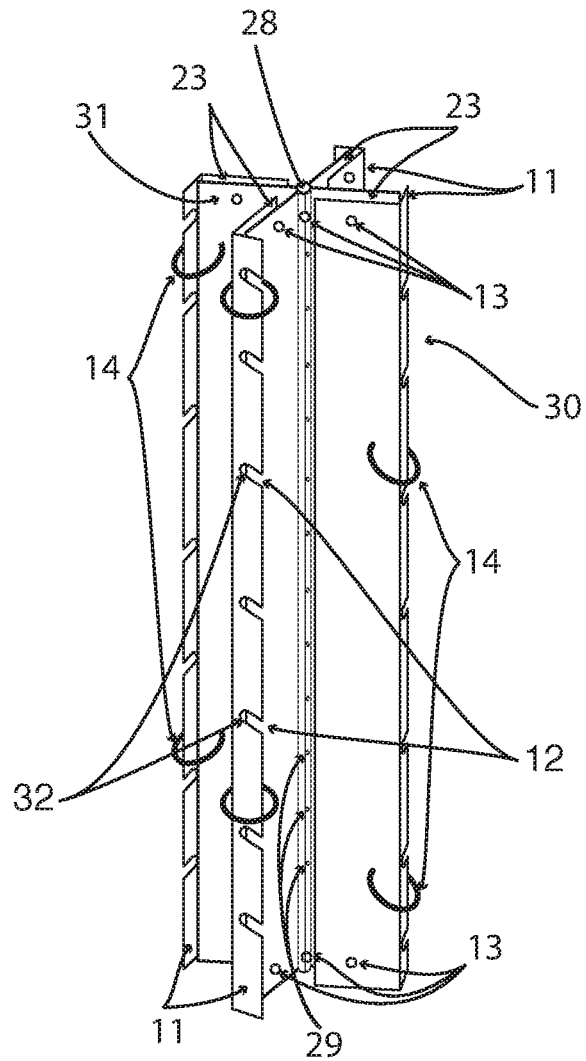

FIG. 13

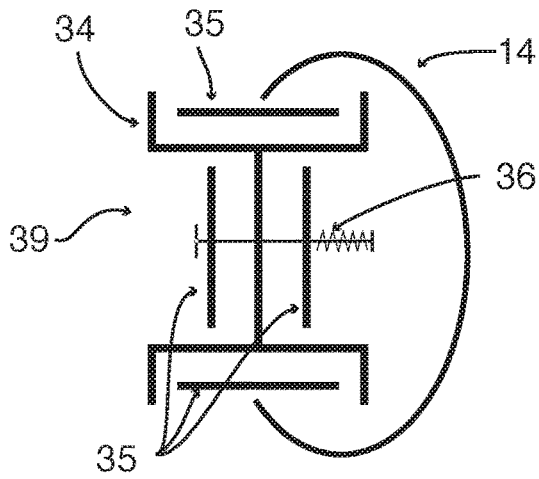

FIG. 14

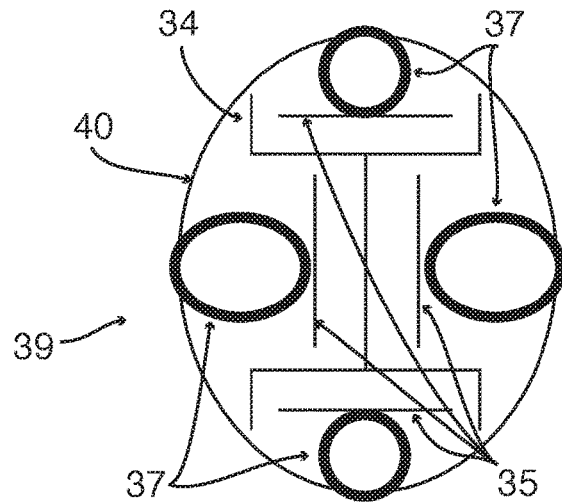

FIG. 15

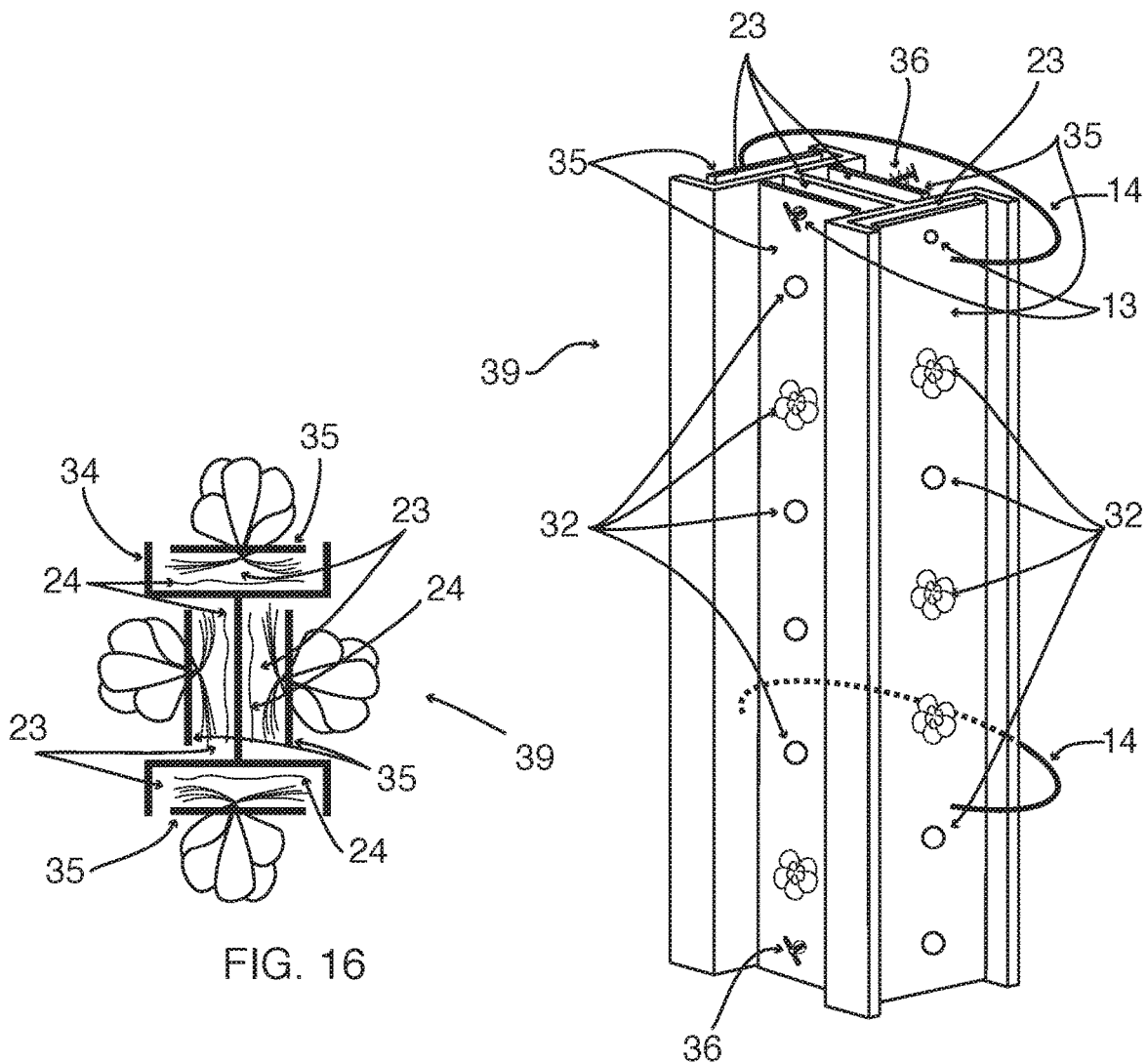

FIG. 16

FIG. 17

MODULAR HYDROPONIC GROWING APPARATUS AND SYSTEM

This application is a continuation of U.S. patent application Ser. No. 16/504,880, filed Jul. 8, 2019, which is incorporated herein in its entirety.

FIELD OF THE INVENTION

This invention relates generally to a hydroponic plant production apparatus greenhouse plant production. In particular, the present invention provides various modular hydroponic growing apparatuses, each having oppositely positioned slats or other compatible surfaces between which is defined an expandable growth channel, wherein at least one of the slates or other compatible surfaces are biased inwardly towards the opposing slat or other compatible surface via a biasing element.

BACKGROUND OF INVENTION

Traditional hydroponics has focused primarily on horizontally oriented growing techniques and is limited by the inherent space constraints of that orientation. Vertically oriented hydroponic systems are known and widely used, but have the disadvantage of limited crop production due to inefficient and bulky square or round tubular designs, as well as restrictive growing media and other growing conditions required by these types of systems. For example, the constraints of these designs require an inefficient use of vertical and horizontal space, such that these systems are unable to take advantage of the variable space needs of crops at different life stages and sizes. Such vertical systems further require bulky growing media to fill tubes and support the growing plants. This media, whether organic or synthetic, has a short production lifespan as it quickly becomes clogged and contaminated, thereby requiring frequent replacement and disposal, as well as posing the risk of becoming a health hazard to the vegetation and the individuals maintaining these systems.

Therefore, there exists an unmet need for hydroponic apparatuses and systems which address and overcome at least some of the challenges set forth herein. The present invention provides such an apparatus and system.

BRIEF SUMMARY OF THE INVENTION

As illustrated in FIGS. 1-17, the present invention is a hydroponic L-shaped slat vertical plant growing apparatus, a second embodiment with a static core of spokes radiating outwardly from a central hub surrounded by L-shaped slats, and a third embodiment of a dynamic-slat apparatus with a static core surrounded by dynamic-slats allowing vertical hydroponic greenhouse crop production in a fraction of the space required by traditional horizontal growing techniques and improving significantly on prior art vertical hydroponic production designs. There are numerous distinct benefits of the hydroponic L-shaped slat vertical plant growing apparatus of the present invention and its various embodiments over other commercially available systems. The shared principal in these various embodiments is the dynamic expandability of oppositely positioned L-shaped slats placed against each other, L-shaped slats placed against a spoked central hub, or dynamic-slats placed against a static central core. When a young plant is placed in a growth aperture of any of these embodiments, the combination of any of those dynamic surfaces against the static surfaces

creates an interior growing space wherein fertigation solution may flow and plants roots may expand as a plant grows. The width of either face of the pair of slats can be varied depending on the intended plant variety(s) to be grown in the apparatus. The slats can be any length. In some instances, notches are formed into a face of each slat and vary in size and spacing according to the requirements of a plant variety being grown. In some instances, the notches comprise an open end that extends out through an edge of the slat. Each slat further comprises an inner face surface, wherein the pair of slats are arranged such that the inner face surface of each slat is positioned opposite to one another, wherein a space between the opposed interface surfaces forms a growth channel along at least a portion of the length of the pair of slats. The growth channel comprises an adjustable width defined by a distance between the opposing inner face surfaces. The growing apparatus further comprises a biasing element that contacts an outer surface of at least one of the slats, wherein the biasing element biases at least one of the slats inwardly towards the opposing slat, such that the inner surface of at least one of the opposing slats is biased towards the inner surface of the opposing slat. In some instances, both opposing slats are biased inwardly towards one another via the biasing means.

In some instances, the growth channel further comprises at least one of a moisture/root barrier and a moisture wicking material. In some instances, a growth channel is divided into two or more sub-growth channels via a moisture barrier. In some instances, the hydroponic growing apparatus is suspended in a generally vertical orientation such that water may flow through a top opening of the growth channel and exit a lower opening of the growth channel via gravitational force. In some instances, the apparatuses and systems of the present invention can be used in multi-angled crop production and multi-storied conveyor-style crop production facilities and operations.

BRIEF DESCRIPTION OF THE DRAWINGS

FIG. 1 depicts a front perspective view illustrating a pair of L-shaped slats in an assembled configuration wherein the inner faces of the opposing slats provide a growth channel therebetween in accordance with a representative embodiment of the present invention;

FIG. 2 depicts a detailed perspective view of the pair of L-shaped slats in FIG. 1;

FIG. 3 depicts an exploded perspective view of the pair of L-shaped slats of FIG. 1;

FIG. 4 depicts top views of various representative L-shaped slats having alternative inner surface configurations in accordance with various representative embodiments of the present invention;

FIG. 5 depicts a front view illustrating the short arm of a L-shaped slat in accordance with a representative embodiment of the present invention;

FIG. 6 depicts a top view of an assembled hydroponic growing apparatus of the present invention in accordance with a representative embodiment of the present invention;

FIG. 7 depicts various types of biasing elements in accordance with various representative embodiments of the present invention;

FIG. 8 depicts a perspective view illustrating the placement and relative size of a moisture wicking material and a moisture barrier in accordance with various representative embodiments of the present invention;

FIG. 9 depicts a perspective view illustrating an array configuration of a plurality of assembled L-shaped slats,

wherein the pairs of slats are added to the array in a modular manner in accordance with a representative embodiment of the present invention;

FIG. 10 depicts a top view of a hydroponic growing apparatus having a non-linear or multi-sided core for use with a plurality of L-shaped slats in accordance with a representative embodiment of the present invention;

FIG. 11 depicts top view of the non-linear or multi-sided core section of FIG. 10;

FIG. 12 depicts a top view of a non-linear or multi-sided core section of a hydroponic growing apparatus in accordance with a representative embodiment of the present invention;

FIG. 13 depicts a perspective view of an assembled multi-sided hydroponic growing apparatus in accordance with a representative embodiment of the present invention;

FIG. 14 depicts a top view of an assembled multi-sided hydroponic growing apparatus in accordance with a representative embodiment of the present invention;

FIG. 15 depicts a top view of an assembled multi-sided hydroponic growing apparatus comprising a circular biasing element in accordance with a representative embodiment of the present invention.

FIG. 16 depicts a top view of an assembled multi-sided hydroponic growing apparatus with moisture wicking material and shown with plants in accordance with a representative embodiment of the present invention; and

FIG. 17 depicts a perspective view of the assembled multi-sided hydroponic growing apparatus of FIG. 16 in accordance with a representative embodiment of the present invention.

DETAILED DESCRIPTION OF THE PREFERRED EMBODIMENTS

The present invention provides various modular hydroponic growing apparatuses, each having oppositely positioned slats or other compatible surfaces between which is defined an expandable growth channel, wherein at least one of the slats or other compatible surfaces are biased inwardly towards the opposing slat or other compatible surface via a biasing element. In some embodiments, the present invention further provides multi-sided hydroponic growing apparatuses.

Referring now to FIG. 1, an assembled hydroponic vertical plant growing apparatus 10 is shown. In some embodiments, apparatus 10 comprises a pair of L-shaped slats 11 which are positioned opposite to one another such that a growing channel 23 is defined by a space between the slats. In some embodiments, the L-shaped slats each comprise a long arm 11a and a short arm 11b, and are assembled such that the leading edge of each long arm 11a contacts or is placed in close proximity to the inner surface of the short arm 11b of the oppositely positioned L-shaped slat. Accordingly, growing channel 23 is more precisely defined by a constant width between the inner surfaces of the oppositely positioned inner surfaces of the short arms 11b, and the varying width between the inner surfaces of the opposing long arms 11a. Thus, the size or volume of growing channel 23 may vary as the positions of the L-shaped slats 11 are adjusted inwardly and outwardly relative to one another.

In some embodiments, slats 11 comprise a material that is compatible for use in hydroponic growing environments and conditions. For example, in some embodiments slats 11 comprise a material that is non-corrosive, nonabsorbent, substantially rigid, and food-safe. Non-limiting examples of suitable materials for slats 11 include polyvinyl chloride,

polycarbonate, polypropylene, stainless steel, and various composite materials, such as fiberglass and carbon fiber materials. In some embodiments, slats 11 comprise a flexible or semi-flexible material, such as a rubber polymer material capable of expanding or stretching in response to plant root development within growing channel 23.

The various components of hydroponic growing apparatus 10 may comprise any size compatible with an intended use. In some embodiments, long arm 11a is approximately 3.5 inches wide, and short arm 11b is approximately 1 inch wide. These dimensions may vary to accommodate a desired crop and/or crop density.

Growing apparatus 10 further comprises one or more biasing elements 14. In some embodiments, biasing element 14 is a spring fastener comprising a broken ring of resilient material, wherein the ends of the spring fastener are configured to contact the outer surfaces of each long arm 11a to bias the opposing slats 11 inwardly towards one another. Between the L-shaped slats 11 is the root growth space 23. In this embodiment both opposing vertical surfaces of the L-shaped slats are dynamic. When fastened together by the spring fastening clips 14, the apparatus 10 is light, portable, easily handled for loading and unloading, durable, reusable, and because the two halves come apart, they can be thoroughly sanitized after each grow cycle. Unlike other vertical hydroponic or aquaponic systems there is no growing media in the L-shaped slat hydroponic growing apparatus 10. Growing media has several potential disadvantages. It is an expense for the grower. It requires much more handling/time/effort. Because it encourages microbial growth, it dramatically increases the risk of contamination over systems that do not use media. Media can transfer plant diseases from one crop rotation to the next. The disposable wicking strip 24 of the hydroponic L-shaped slat vertical plant growing apparatus 10 of the present invention can be replaced or cleaned each time plants are harvested. There is no media to contaminate or be contaminated by.

Square or round tubes are difficult to clean and sanitize. In those tubes there are interior corners or edges that are difficult to reach or see. The hydroponic L-shaped slat vertical plant growing apparatus 10 of the present invention resolves that issue. When disassembled, both L-shaped slats 11, dynamic-slats 35, and multi-sided static surfaces 31 and 34, are fully exposed and can be completely accessed to be cleaned and sanitized.

FIG. 2 depicts a close-up front perspective view of the hydroponic L-shaped slat vertical plant growing apparatus 10 constructed in accordance with an exemplary embodiment of the present invention more clearly illustrating the plant growing aperture 32 created in the notches 12 when the two oppositely positioned L-shaped slats 11 are brought together and the rearward edge of one L-shaped slat contacts the interior surface of the face of the oppositely positioned L-shaped slat. The plant growing aperture 32 is created when plants are placed in the notches 12 or holes 13 with their roots extending into the growing space 23. These notches 12 or holes 13 can be placed in any position along an L-shaped slat or a dynamic-slat 35 depending on the type of crop being produced. The hydroponic L-shaped slat vertical plant growing apparatus 10 of the present invention is preferably constructed of a PVC material or other similar strong, flexible, food-safe material.

FIG. 3 depicts a perspective view illustrating the two separated halves of the hydroponic L-shaped slat vertical plant growing apparatus 10 of FIG. 1 constructed in accordance with an exemplary embodiment of the present invention. This illustration shows an expanded view of the hydro-

5

ponic L-shaped slat vertical plant growing apparatus **10** of FIG. **1** wherein a pair of oppositely positioned L-shaped slats **11** are aligned in space to illustrate their ultimate positioning in relation to one another. It also illustrates that any of the embodiments of the apparatus **10**, **30**, or **39** may be manufactured in any length or width.

FIG. **4** depicts a top view illustrating the L-shaped slats of FIG. **1** and some potential surface embodiments constructed in accordance with an exemplary embodiment of the present invention. Because plant anatomy varies widely and because time-to-harvest can be from 4 weeks to 30 weeks it is important to accommodate adequate fertigation profusion throughout the entire hydroponic L-shaped slat vertical plant growing apparatus **10**. By creating interior surface grooves **16**, ridges **17**, or spacers **18**, roots are less likely to fill all of the voids those irregularities create, thereby allowing sufficient nutrient flow and oxygenation to continue throughout the growth cycle. If necessary, a perforated tube **19** can run the entire length of the hydroponic L-shaped slat vertical plant growing apparatus **10** or any of its alternative embodiments **30** or **39**.

FIG. **5** depicts a front view illustrating the hydroponic L-shaped slat vertical plant growing apparatus of FIG. **1** constructed in accordance with an exemplary embodiment of the present invention. While it is possible to place holes **13** or notches **12** on both faces of each L-shaped slat **11**, notches will primarily be formed on the short face of the L-shaped slat **11b**. These notches **12** are formed horizontally in the face of an L-shaped slat **11b** and open outwardly through the edge of the short side of the face of the L-shaped slat **11b**. The notches **12** or holes **13** may vary in diameter and length according to the crops being grown. FIG. **5** also illustrates that the L-shaped slat **11** may be manufactured in any desired length. It further illustrates that the notches **12** or holes **13** may be placed in the face of the L-shaped slat **11** at any interval, and that the notches **12** or holes **13** may vary in width and length in relation to the dimensions of the face of the L-shaped slat and the crop being produced.

FIG. **6** depicts a top view illustrating both halves of the hydroponic L-shaped slat vertical plant growing apparatus **10** of FIG. **1** being held in place by a circular spring biasing element **14** constructed in accordance with an exemplary embodiment of the present invention. This illustration shows the details of the root growth space **23** and the positioning of the wicking strips **24**, and the plastic strip **25** in relation to the plant roots and the spring biasing element **14**. It illustrates that the gap of the plant growth space **23** is dynamic and expands with the growth of the plant.

FIG. **7** depicts an illustration of a circular spring biasing element used with the hydroponic L-shaped slat vertical plant growing apparatus of FIG. **1** constructed in accordance with an exemplary embodiment of the present invention. The spring biasing elements **14** of the hydroponic L-shaped slat vertical plant growing apparatus **10** of the present invention can be made of the same rigid PVC material as the L-shaped slats **11**, or any other metal or similar clip that will squeeze the two L-shaped slats **11** together, but not so tightly as to constrict fluid movement or root growth. Spring biasing element **14** must be strong enough to hold the slats **11** in place, be noncorrosive, easily sanitized, and durable. They will generally be circular or semicircular in order to fit around the front side of the slat **11**. Swivel-headed spring pins **36** may also be used as biasing elements in place of circular spring biasing elements such as illustrated in FIG. **14** and FIG. **17**. The swivel-head of a swivel-headed spring pin aligns parallel to the pin's shaft to pass through a hole

6

13 then is turned perpendicular to the shaft to hold the L-shaped slat **11** or dynamic-slat **35** against an opposing surface.

FIG. **8** depicts an exemplary perspective view illustrating the placement and relative size of the wicking strip **24** and plastic strip **25** as they are positioned within the root growth space **23**.

FIG. **9** depicts a perspective view illustrating an exemplary potential array configuration of multiple hydroponic L-shaped slat vertical plant growing apparatus **10** of FIG. **1** constructed in accordance with an exemplary embodiment of the present invention.

The hydroponic L-shaped slat vertical plant growing apparatus **10** can be suspended vertically by a suspension device such as a pin, S-hook, clip, chain or other fastener **22** placed through the hole **13** at either end of the L-shaped slat **11**, dynamic-slat **35**, spoked static core **31**, or another static core **34**. Because the paired L-shaped slats **11**, dynamic-slats **35**, spoked static cores **31**, or another static cores **34** parts mirror one another there is no top or bottom. The hydroponic L-shaped slat vertical plant growing apparatus **10** can be attached via its suspension device **22** to any horizontal bar, rod, track, automatic rotator or roller system **20** for easy placement, adjustment or removal.

Once suspended, the position of the hydroponic L-shaped slat vertical plant growing apparatus **10**, dynamic-slat **35**, spoked static core **31**, or another static core **34** of the present invention can be adjusted manually, via an automated system or if the apparatus **10** has been suspended on a roller system the actual growth of the plants may push each separate apparatus **10** away from the one beside it, thereby self-adjusting its spacing. The apparatus **10** may be configured and used in automated, mobile or transportable modules.

To load or place plants into the hydroponic L-shaped slat vertical plant growing apparatus **10** of the present invention, one slat **11** will be placed horizontally on a table, notched **12** side up. A clean, wet fiber wicking strip **24**, approximately the same width as the long side **1/a** of the L-shaped slat **11**, will be placed along the length of the slat **11**. The wicking strip **24** will keep roots moist between fertigation intervals. It will be held in place at the top of the slat **11** by the suspension device **22** or a separate biasing element. Seedlings will be laid on the wicking strip **24** with their roots toward the inside of the apparatus **10** and the leaves will extend through the notch **12**. This area will become the root growing space **23** once the apparatus **10** is assembled. At this point, if both sides of the double-sided apparatus **10** are being planted, and depending on varietal plant root requirements, a thin moisture/root barrier **25** similar in size to the wicking strip may be laid down on top of the first row of roots. A row of plants facing the opposite direction is laid down on that plastic strip in the position of the notches **12** of the oppositely positioned L-shaped slat **11**. Another wet wicking strip **24** is laid along the length of the slat **11** over those roots. A second L-shaped slat **11**, facing the opposite direction, with the notches **12** down, is placed down over the seedlings. Biasing elements **14** are placed around the body of the apparatus **10** to hold the two parts together and keep the seedlings in place. A hook or pin **22** is placed through the hole **13** and the wicking strips **24** and moisture/root barrier strip **25** (if one is being used). The apparatus **10** is then placed on the overhead weight bearing structure. The bottom of the device **10** can be left in a vertical axis or inclined to whatever angle is desired. To minimize sway, add stability or incline the array towards horizontal, a connecting rod or dowel could also be run

though the holes **13** at the bottoms of an array of suspended hydroponic L-shaped slat vertical plant growing apparatus **10** of the present invention.

A length of fertigation tubing **21** is run along the top of an array of hydroponic L-shaped slat vertical plant growing apparatus **10** of the present invention which is suspended from a horizontal bar, rod, track or roller system **20**. A secondary length of tubing **19**, connected to the fertigation tubing **21** is inserted between the two slats **11** of the apparatus **10** into the root growing space **23**. A pump and timer control the frequency and amount of nutrient solution pumped into the top of each apparatus **10**. Gravity and capillary action circulate the nutrient solution to the bottom of the apparatus **10**, passing it over the roots of the plants. The production process of the L-shaped slats **11** might also include modifications to the smooth inner surface **15** of the slats **11** to include such variations as grooves **16**, ridges **17** or spacers **18** to facilitate better nutrient flow over the plant roots. Different root types may require unique surface modifications. Thin perforated tubing **19** could also be placed along the interior length of the apparatus **10** to insure nutrient solution reaches every plant. The bottom of each apparatus **10** can drain into any sort of gutter or tubing to flow via gravity or be pumped back to a nutrient tank to be recirculated.

Harvesting plants from the hydroponic L-shaped slat vertical plant growing apparatus **10** of the present invention is achieved by separating the suspension device **22** of the apparatus **10** from the overhead structure **20** and fertigation tubing **19**, laying the apparatus **10** horizontally on a table, and removing the biasing elements **14** or **36**. The top slat **11** is lifted away, plants are gathered for processing. The wicking strip **24** and moisture/root barrier **25** are cleaned or discarded. The L-shaped slats **11** and moisture/root barrier **25** are then sanitized and the process of planting is repeated.

While one of the potential benefits of vertical hydroponics is greater plant density per square meter of growing space, other vertical systems fall short of that potential because they are limited by large bulky square or round tubes, they can be clumsy to handle, planting media can potentially become contaminated, and the sheer bulk of the tubing limits narrower spacing options. For many weeks small plants require only inches of space, yet tubular towers and their racks consume feet of space and cannot take advantage of the weeks of potentially greater plant density available with young plants. The hydroponic L-shaped slat vertical plant growing apparatus **10** of the present invention can nest next to another hydroponic L-shaped slat vertical plant growing apparatus **10** within the width of the front face of the slat **11b** for several weeks during the initial phases of plant growth. That means fewer lights are needed for fewer days per crop. That means a greater plant density per square meter of production. Additionally the hydroponic L-shaped slat vertical plant growing apparatus **10** of the present invention is multi-sided. It can produce plants on multiple faces of its structure, thereby potentially more than sextupling the capacity of single-sided four inch wide tubular structures on the same footprint, during the first weeks of crop production.

The hydroponic L-shaped slat vertical plant growing apparatus **10** of the present invention and its various embodiments **30** and **39** allow for a significant reduction of water usage over conventional agriculture and even improvements over other vertical hydroponic systems. Since the hydroponic L-shaped slat vertical plant growing apparatus **10** is multi-sided it can grow more plant material per

gallon/per kilowatt expended on pumping and evaporation since fewer apparatus **10** are needed to produce a given number of plants.

The hydroponic L-shaped slat vertical plant growing apparatus **10** of the present invention and its various embodiments **30** and **39** can also be used with modular aquaponic systems.

FIG. **10** depicts an exemplary top view of a multi-sided iteration of the hydroponic L-shaped slat vertical plant growing apparatus **30** of FIG. **1** constructed in accordance with an exemplary embodiment of the present invention. It is possible to use L-shaped slats **11** around a multi-sided static central post **27** which may or may not have a hollow center core **28** through which nutrient solution might flow and reach the plant growth space **23** via small holes **29**. A multi-sided static central post **27** could be configured with any number of sides, as spokes radiating out from the center hub **28**. All L-shaped slat **11** configurations may be manufactured in any length and width. This alternative embodiment could be automatically rotated individually or as an array or module toward or around a light source on a predetermined schedule via mechanization, or manually adjusted.

FIG. **11** and FIG. **12** depict exemplary top views of a multi-sided iteration of the hydroponic L-shaped slat vertical plant growing apparatus **10** of FIG. **1** constructed in accordance with an exemplary embodiment of the present invention. The drawings illustrate that this embodiment **30** has a multi-sided central post **31** and may have any number of spokes **27**. Each spoke **27** of the multi-sided central post **31** would pair with an L-shaped slat **11** and function as previously described.

It is also conceivable to create multi-sided embodiments of the L-shaped slat growing apparatus **30** and **39** of the present invention **10**. It is possible to use L-shaped slats **11** around a multi-sided static central post **31** which may or may not have a hollow center core **28** through which nutrient solution might flow and reach the plant growth space **23** via small fertigation holes **29**. A multi-sided static central post **31** could be configured with any number of sides/spokes **27** emanating out from a center hub **28**. All L-shaped slat **11** configurations may be manufactured in any length and width. This alternative embodiment **30** could be automatically rotated toward a light source on a predetermined schedule via mechanization, or manually adjusted. Or a cluster of these suspended apparatus **30** could be rotated toward or around a central light source.

FIG. **13** depicts an exemplary perspective view of a multi-sided iteration of the hydroponic L-shaped slat vertical plant growing apparatus **10** of FIG. **1** constructed in accordance with an exemplary embodiment of the present invention. This view illustrates how this embodiment of the L-shaped slat vertical plant growing apparatus **30** might appear if it were assembled and operating. Plant illustrations were omitted from the drawing to better clarify the structure of the multi-sided apparatus **30**.

FIG. **14** depicts an exemplary top view of a multi-sided embodiment of the hydroponic L-shaped slat vertical plant growing apparatus **10** of FIG. **1** constructed in accordance with an exemplary embodiment of the present invention. This illustration depicts the positional relationship between a possible iteration of a multi-sided static core **34**, the dynamic-slats **35**, biasing elements of the swivel-headed pin fasteners **36**, and the spring fasteners **14**.

FIG. **15** depicts an exemplary top view of a multi-sided iteration of the hydroponic L-shaped slat vertical plant growing apparatus **10** of FIG. **1** constructed in accordance

with an exemplary embodiment of the present invention. This illustration depicts the positional relationship between a possible iteration of a multi-sided static core 34, the dynamic-slats 35, and a multiplicity of biasing elements such as elastic tighten bands or adjustable straps 40 being used in combination with or instead of swivel-headed pins 36 or spring fasteners 14. Since the size and shape of the static core 34 and the dynamic-slats 35 of the apparatus 39 may vary, proper positioning of the dynamic-slats 35 may be maintained by using a rubber band-like strap 40 to apply pressure equally against the biasing elements 37 inwardly and hold the biasing elements 37 in place against the dynamic-slats 35. These biasing elements 37 could be made of any suitable lightweight material such as segments of PVC tubing or wooden blocks. They could be hollow or solid.

FIG. 16 depicts an exemplary top view of a multi-sided iteration of the hydroponic L-shaped slat vertical plant growing apparatus 10 of FIG. 1 constructed in accordance with an exemplary embodiment of the present invention. This illustration depicts the positional relationship within the apparatus 39 between a possible iteration of a static core 34, the dynamic-slats 35, the wicking strips 24 and the plant growing spaces 23. It omits any fasteners from the illustration to more clearly depict how plants, the plant growing spaces 23 and the wicking strips 24 might appear in relation to one another.

FIG. 17 depicts an exemplary perspective view of a multi-sided iteration of the hydroponic L-shaped slat vertical plant growing apparatus 10 of FIG. 1 constructed in accordance with an exemplary embodiment of the present invention. It depicts what a multi-sided iteration 39 might look like if it was assembled and operating and the potential positioning of holes 13/growth apertures 32 in the dynamic-slats 35. The growth aperture 32 is created when plants are placed into the holes 13 and the dynamic-slat 35 is mated and held in place by pressure from a biasing element 14 or swivel-headed spring pin 36 to a static surface 34. In crop production each hole 13 may have a plant protruding from it. To illustrate this, a depiction of some plants has been included in some of the holes 13/plant apertures 32 to clearly illustrate how they would be positioned in production. Both swivel-headed spring pins 36 and circular fastener biasing elements 14 are depicted holding the dynamic-slats 35 against the static core 34. As with the L-shaped slat apparatus 10, and the multi-sided L-shaped slat apparatus 30, the multi-sided dynamic slat apparatus 39 may be manufactured in any size or length to be used in any stand alone, multi-storied, automated, manually adjusted or modular configuration.

The foregoing exemplary descriptions and the illustrative preferred embodiments of the present invention have been explained in the drawings and described in detail, with various modifications and alternative embodiments being taught. While the invention has been so shown, described and illustrated, it should be understood by those skilled in the art that equivalent changes in form and detail may be made therein without departing from the true spirit and scope of the present invention, and that the scope of the present invention is only to be limited to the claims except to be precluded by the prior art.

Moreover, the invention as disclosed herein, may be suitably practiced in the absence of the specific elements which are disclosed herein.

The invention claimed is:

1. A hydroponic growing apparatus, comprising:
 - a first L-shaped slat having a first long arm and a first short arm, the first long arm comprising a first inner surface and a first outer surface;
 - a second L-shaped slat having a second long arm and a second short arm, the second long arm comprising a second inner surface and a second outer surface, wherein the second L-shaped slat is positioned opposite the first L-shaped slat such that first long arm is perpendicular to and extends outwardly from the second short arm, and the second long arm is perpendicular to and extends outwardly from the first short arm, such that the first inner surface is positioned opposite the second inner surface thereby forming a growth channel between opposing first and second inner surfaces; and
 - a biasing element having a first contact surface configured to contact the first outer surface, and a second contact surface configured to contact the second outer surface, the biasing element configured to bias the first and second inner surfaces inwardly towards one another.
2. The apparatus of claim 1, wherein the first and second L-shaped slats are separate components.
3. The apparatus of claim 1, wherein the growth channel comprises an adjustable width.
4. The apparatus of claim 1, wherein the growth channel comprises a moisture wicking material.
5. The apparatus of claim 1, wherein the growth channel extends along an entire length of the first and second L-shaped slats.
6. The apparatus of claim 1, wherein the biasing member is selected from the group consisting of a spring fastener and a band clamp.
7. The apparatus of claim 1, wherein the growth channel comprises a moisture barrier.
8. The apparatus of claim 7, wherein the moisture barrier divides the growth channel into a plurality of sub-growth channels.
9. The apparatus of claim 1, further comprising a first plurality of notches formed in and extending outwardly through a first leading edge of the first L-shaped slat.
10. The apparatus of claim 9, wherein the first short arm comprises the first leading edge.
11. The apparatus of claim 10, further comprising a second plurality of notches formed in and extending outwardly through a second leading edge of the second L-shaped slat.
12. The apparatus of claim 11, wherein the second short arm comprises the second leading edge.
13. The apparatus of claim 1, wherein at least one of the first and second L-shaped slats comprise a hole configured to receive a suspension device for vertically suspending the apparatus.
14. The apparatus of claim 1, wherein the first L-shaped slat consists essentially of a monolithic structure.
15. The apparatus of claim 1, wherein the second L-shaped slat consists essentially of a monolithic structure.
16. A hydroponic system comprising a plurality of first and second L-shaped slats according to claim 1.
17. The system of claim 16, wherein each of the plurality of first and second L-shaped slats comprise a hole configured to receive a suspension device for vertically suspending the first and second L-shaped slats.
18. The system of claim 17, further comprising a track system configured to receive, store, and move the vertically suspended first and second L-shaped slats.