



- (51) International Patent Classification:  
G06F 3/0481 (2013.01) G06F 9/44 (2006.01)
- (21) International Application Number:  
PCT/US2017/035376
- (22) International Filing Date:  
01 June 2017 (01.06.2017)
- (25) Filing Language: English
- (26) Publication Language: English
- (30) Priority Data:  
62/348,984 12 June 2016 (12.06.2016) US  
15/609,695 31 May 2017 (31.05.2017) US
- (71) Applicant: APPLE INC. [US/US]; 1 Infinite Loop, M/S 169-3IPL, Cupertino, California 95014 (US).
- (72) Inventors: DUNN, Corbin Robert; 1 Infinite Loop, M/S 169-3IPL, Cupertino, California 95014 (US). LOUCH, John O.; 1 Infinite Loop, M/S 169-3IPL, Cupertino, Cal-

ifornia 95014 (US). VAN VECHTEN, Kevin James; 1 Infinite Loop, M/S 169-3IPL, Cupertino, California 95014 (US). COFFMAN, Patrick Lee; 1 Infinite Loop, M/S 169-3IPL, Cupertino, California 95014 (US). STEPHENS, Troy N.; 1 Infinite Loop, M/S 169-3IPL, Cupertino, California 95014 (US).

(74) Agent: FERNANDO, Ronald S.; Squire Patton Boggs (US) LLP, Fernando Team, 1801 Page Mill Road, Suite 110, Palo Alto, CA 94304 (US).

(81) Designated States (unless otherwise indicated, for every kind of national protection available): AE, AG, AL, AM, AO, AT, AU, AZ, BA, BB, BG, BH, BN, BR, BW, BY, BZ, CA, CH, CL, CN, CO, CR, CU, CZ, DE, DJ, DK, DM, DO, DZ, EC, EE, EG, ES, FI, GB, GD, GE, GH, GM, GT, HN, HR, HU, ID, IL, IN, IR, IS, JP, KE, KG, KH, KN, KP, KR, KW, KZ, LA, LC, LK, LR, LS, LU, LY, MA, MD, ME, MG, MK, MN, MW, MX, MY, MZ, NA, NG, NI, NO, NZ, OM, PA, PE, PG, PH, PL, PT, QA, RO, RS, RU, RW, SA, SC,

(54) Title: DEVICE, METHOD, AND GRAPHICAL USER INTERFACE FOR WINDOW MANIPULATION AND MANAGEMENT

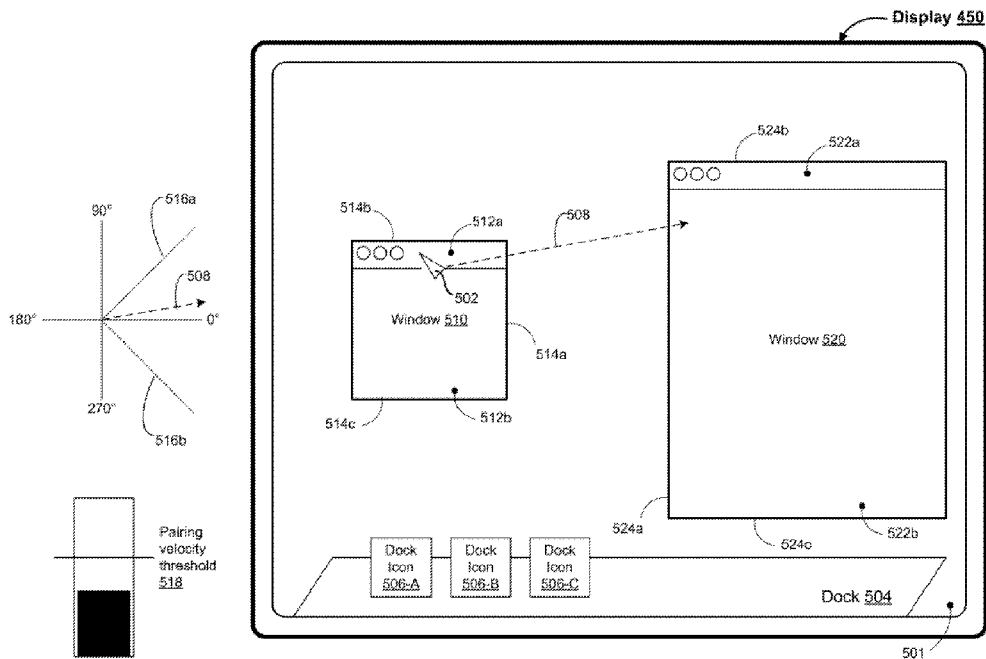

Figure 5A

(57) Abstract: An electronic device: pairs a first edge of a first window to a second edge of a second window when a user input corresponds to movement of the first edge toward the second edge that deviates from a predefined axis by less than an angular threshold value. Alternatively depending on a type of a user input the device either resizes a dimension of a window or moves one or more edges of the window to corresponding edges of a display area while maintaining respective one or more opposite edges of the first window. Alternatively the device: adds a second window as a new tab within a tab bar associated with a first window when the first window is displayed in full screen mode, and the device adds the second window separate from the first window within a display area when the first window is displayed in windowed mode.



SD, SE, SG, SK, SL, SM, ST, SV, SY, TH, TJ, TM, TN, TR,  
TT, TZ, UA, UG, US, UZ, VC, VN, ZA, ZM, ZW.

- (84) Designated States** (*unless otherwise indicated, for every kind of regional protection available*): ARIPO (BW, GH, GM, KE, LR, LS, MW, MZ, NA, RW, SD, SL, ST, SZ, TZ, UG, ZM, ZW), Eurasian (AM, AZ, BY, KG, KZ, RU, TJ, TM), European (AL, AT, BE, BG, CH, CY, CZ, DE, DK, EE, ES, FI, FR, GB, GR, HR, HU, IE, IS, IT, LT, LU, LV, MC, MK, MT, NL, NO, PL, PT, RO, RS, SE, SI, SK, SM, TR), OAPI (BF, BJ, CF, CG, CI, CM, GA, GN, GQ, GW, KM, ML, MR, NE, SN, TD, TG).

**Declarations under Rule 4.17:**

- *as to applicant's entitlement to apply for and be granted a patent (Rule 4.17(ii))*

**Published:**

- *with international search report (Art. 21(3))*
- *before the expiration of the time limit for amending the claims and to be republished in the event of receipt of amendments (Rule 48.2(h))*

## **Device, Method, and Graphical User Interface for Window Manipulation and Management**

### TECHNICAL FIELD

**[0001]** This relates generally to electronic devices with displays and input devices, including but not limited to electronic devices with displays that enable window manipulation and management using input devices.

### BACKGROUND

**[0002]** The use of touch-sensitive surfaces as input devices for computers and other electronic computing devices has increased significantly in recent years. Example touch-sensitive surfaces include touchpads and touch-screen displays. Such surfaces are widely used to manipulate user interface objects on a display.

**[0003]** Example manipulations include adjusting the position and/or size of one or more user interface objects or activating buttons or opening files/applications represented by user interface objects, as well as associating metadata with one or more user interface objects or otherwise manipulating user interfaces. Example user interface objects include digital images, video, text, icons, control elements such as buttons and other graphics. A user will, in some circumstances, need to perform such manipulations on user interface objects in a file management program (e.g., Finder from Apple Inc. of Cupertino, California), an image management application (e.g., Aperture, iPhoto, Photos from Apple Inc. of Cupertino, California), a digital content (e.g., videos and music) management application (e.g., iTunes from Apple Inc. of Cupertino, California), a drawing application, a presentation application (e.g., Keynote from Apple Inc. of Cupertino, California), a word processing application (e.g., Pages from Apple Inc. of Cupertino, California), a website creation application (e.g., iWeb from Apple Inc. of Cupertino, California), a disk authoring application (e.g., iDVD from Apple Inc. of Cupertino, California), or a spreadsheet application (e.g., Numbers from Apple Inc. of Cupertino, California).

**[0004]** But methods for performing these manipulations are cumbersome and inefficient. For example, using a sequence of mouse based inputs to select one or more user interface objects and perform one or more actions on the selected user interface objects is

tedious and creates a significant cognitive burden on a user. In addition, these methods take longer than necessary, thereby wasting energy. This latter consideration is particularly important in battery-operated devices.

#### SUMMARY

**[0005]** Accordingly, there is a need for electronic devices with faster, more efficient methods and interfaces for window manipulation and management. Such methods and interfaces optionally complement or replace conventional methods for window manipulation and management. Such methods and interfaces reduce the cognitive burden on a user and produce a more efficient human-machine interface. For battery-operated devices, such methods and interfaces conserve power and increase the time between battery charges.

**[0006]** The above deficiencies and other problems associated with user interfaces for electronic devices with touch-sensitive surfaces are reduced or eliminated by the disclosed devices. In some embodiments, the device is a desktop computer. In some embodiments, the device is portable (e.g., a notebook computer, tablet computer, or handheld device). In some embodiments, the device has a touchpad. In some embodiments, the device has a touch-sensitive display (also known as a “touch screen” or “touch-screen display”). In some embodiments, the device has a graphical user interface (GUI), one or more processors, memory and one or more modules, programs or sets of instructions stored in the memory for performing multiple functions. In some embodiments, the user interacts with the GUI primarily through stylus and/or finger contacts and gestures on the touch-sensitive surface. In some embodiments, the functions optionally include image editing, drawing, presenting, word processing, website creating, disk authoring, spreadsheet making, game playing, telephoning, video conferencing, e-mailing, instant messaging, workout support, digital photographing, digital videoing, web browsing, digital music playing, and/or digital video playing. Executable instructions for performing these functions are, optionally, included in a non-transitory computer readable storage medium or other computer program product configured for execution by one or more processors.

**[0007]** In accordance with some embodiments, a method is performed at a device with one or more processors, non-transitory memory, a display, and an input device. The method includes: displaying, on the display, a first window and a second window within a display area, the first window having a first edge parallel to a second edge of the second window; and

detecting a first user input, via the input device, moving the first edge of the first window toward the second edge of the second window. In response to detecting the first user input, and in accordance with a determination that the first user input satisfies one or more pairing criteria, the method includes pairing the first edge of the first window to the second edge of the second window such that the first window stops moving in response to the first user input before it overlaps the second window, where the one or more pairing criteria include a first pairing criterion that is met when the first input corresponds to movement of the first edge toward the second edge that deviates from a predefined axis by less than an angular threshold value. In response to detecting the first user input, and in accordance with a determination that the first user input does not satisfy the one or more pairing criteria, the method further includes continuing the movement of the first window based on the first user input so that the first window at least partially overlaps the second window.

**[0008]** In accordance with some embodiments, a method is performed at a device with one or more processors, non-transitory memory, a display, and an input device. The method includes: displaying, on the display, a first window in a display area; and detecting a first user input, via the input device, associated with one or more edges of the first window. In response to detecting the first user input, and in accordance with a determination that the first user input corresponds to a first input type, the method also includes resizing one or more dimensions of the first window that correspond to the one or more edges of the first window based on a movement vector associated with the first user input. In response to detecting the first user input, and in accordance with a determination that the first user input corresponds to a second input type, the method further includes moving the one or more edges of the first window to one or more corresponding edges of the display area while maintaining respective one or more opposite edges of the first window.

**[0009]** In accordance with some embodiments, a method is performed at a device with one or more processors, non-transitory memory, a display, and an input device. The method includes: displaying, on the display, a first window associated with a first application within a display area; and detecting a first user input, via the input device, that corresponds to a request to add a second window associated with the first application. In response to detecting the first user input, and in accordance with a determination that the first window is displayed within the display area in full screen mode, the method also includes adding the second window as a new tab within a tab bar associated with the first window. In response to

detecting the first user input, and in accordance with a determination that the first window is displayed within the display area in windowed mode, the method further includes displaying the second window separate from the first window within the display area.

**[0010]** In accordance with some embodiments, an electronic device includes a display unit configured to display a user interface, one or more input units configured to receive user inputs, and a processing unit coupled with the display unit and the one or more input units. The processing unit is configured: enable display of, on the display unit, a first window and a second window within a display area, the first window having a first edge parallel to a second edge of the second window; and detect a first user input, via the one or more input units, moving the first edge of the first window toward the second edge of the second window. In response to detecting the first user input, and in accordance with a determination that the first user input satisfies one or more pairing criteria, the method processing unit is further configured to pair the first edge of the first window to the second edge of the second window such that the first window stops moving in response to the first user input before it overlaps the second window, where the one or more pairing criteria include a first pairing criterion that is met when the first input corresponds to movement of the first edge toward the second edge that deviates from a predefined axis by less than an angular threshold value. In response to detecting the first user input, and in accordance with a determination that the first user input does not satisfy the one or more pairing criteria, the method processing unit is further configured to continue the movement of the first window based on the first user input so that the first window at least partially overlaps the second window.

**[0011]** In accordance with some embodiments, an electronic device includes a display unit configured to display a user interface, one or more input units configured to receive user inputs, and a processing unit coupled with the display unit and the one or more input units. The processing unit is configured to: enable display of, on the display unit, a first window in a display area; and detect a first user input, via the one or more input units, associated with one or more edges of the first window. In response to detecting the first user input, and in accordance with a determination that the first user input corresponds to a first input type, the method processing unit is further configured to resize one or more dimensions of the first window that correspond to the one or more edges of the first window based on a movement vector associated with the first user input. In response to detecting the first user input, and in accordance with a determination that the first user input corresponds to a second input type,

the method processing unit is further configured to move the one or more edges of the first window to one or more corresponding edges of the display area while maintaining respective one or more opposite edges of the first window.

**[0012]** In accordance with some embodiments, an electronic device includes a display unit configured to display a user interface, one or more input units configured to receive user inputs, and a processing unit coupled with the display unit and the one or more input units. The processing unit is configured: enable display of, on the display unit, a first window associated with a first application within a display area; and detect a first user input, via the one or more input units, that corresponds to a request to add a second window associated with the first application. In response to detecting the first user input, and in accordance with a determination that the first window is displayed within the display area in full screen mode, the method processing unit is further configured to add the second window as a new tab within a tab bar associated with the first window. In response to detecting the first user input, and in accordance with a determination that the first window is displayed within the display area in windowed mode, the method processing unit is further configured to enable display of the second window separate from the first window within the display area.

**[0013]** In accordance with some embodiments, an electronic device includes a display, an input device, one or more processors, non-transitory memory, and one or more programs; the one or more programs are stored in the non-transitory memory and configured to be executed by the one or more processors and the one or more programs include instructions for performing or causing performance of the operations of any of the methods described herein. In accordance with some embodiments, a non-transitory computer readable storage medium has stored therein instructions which when executed by one or more processors of an electronic device with a display and an input device, cause the device to perform or cause performance of the operations of any of the methods described herein. In accordance with some embodiments, a graphical user interface on an electronic device with a display, an input device, a memory, and one or more processors to execute one or more programs stored in the non-transitory memory includes one or more of the elements displayed in any of the methods described above, which are updated in response to inputs, as described in any of the methods described herein. In accordance with some embodiments, an electronic device includes: a display, an input device; and means for performing or causing performance of the operations of any of the methods described herein. In accordance with some

embodiments, an information processing apparatus, for use in an electronic device with a display and an input device, includes means for performing or causing performance of the operations of any of the methods described herein.

**[0014]** Thus, electronic devices with displays, touch-sensitive surfaces and optionally one or more sensors to detect intensity of contacts with the touch-sensitive surface are provided with faster, more efficient methods and interfaces for window manipulation and management, thereby increasing the effectiveness, efficiency, and user satisfaction with such devices. Such methods and interfaces may complement or replace conventional methods for window manipulation and management.

#### BRIEF DESCRIPTION OF THE DRAWINGS

**[0015]** For a better understanding of the various described embodiments, reference should be made to the Description of Embodiments below, in conjunction with the following drawings in which like reference numerals refer to corresponding parts throughout the figures.

**[0016]** Figure 1A is a block diagram illustrating a portable multifunction device with a touch-sensitive display in accordance with some embodiments.

**[0017]** Figure 1B is a block diagram illustrating example components for event handling in accordance with some embodiments.

**[0018]** Figure 2 illustrates a portable multifunction device having a touch screen in accordance with some embodiments.

**[0019]** Figure 3 is a block diagram of an example multifunction device with a display and a touch-sensitive surface in accordance with some embodiments.

**[0020]** Figure 4A illustrates an example user interface for a menu of applications on a portable multifunction device in accordance with some embodiments.

**[0021]** Figure 4B illustrates an example user interface for a multifunction device with a touch-sensitive surface that is separate from the display in accordance with some embodiments.

**[0022]** Figures 5A-5MMM illustrate example user interfaces for pairing edges of windows in accordance with some embodiments.



[0023] Figures 6A-6Y illustrate example user interfaces for resizing windows in accordance with some embodiments.

[0024] Figures 7A-7R illustrate example user interfaces for providing tabbed window functionality in accordance with some embodiments.

[0025] Figures 8A-8E illustrate a flow diagram of a method of pairing edges of windows in accordance with some embodiments.

[0026] Figures 9A-9D illustrate a flow diagram of a method of resizing windows in accordance with some embodiments.

[0027] Figures 10A-10C illustrate a flow diagram of a method of providing tabbed window functionality in accordance with some embodiments.

[0028] Figures 11-13 are functional block diagrams of an electronic device in accordance with some embodiments.

#### DESCRIPTION OF EMBODIMENTS

[0029] The use of electronic devices with touch-based user interfaces (e.g., devices such as the iPhone®, iPod Touch®, iPad®, MacBook®, and iMac® devices from Apple Inc. of Cupertino, California) has increased significantly in recent years. These devices use touch-sensitive surfaces, such as a touch screen display or a touch pad, as the main input for manipulating user interface objects on a display and/or controlling the device. These devices may also have contact intensity sensor for determining a force or pressure of contacts with the touch-sensitive surfaces.

[0030] Described below are devices and methods that enable edges of windows to be paired. In some embodiments, when movement of a first edge of a first window toward a second edge of a second window satisfies pairing criteria the first and second edges are paired such that the windows do not overlap. In some embodiments, after the edges are paired, the windows exhibit a “sticky” behavior. As such, according to some embodiments, the user is able to slide windows parallel to one another while the edges maintaining the pairing of the edges.

[0031] Described below are devices and methods that enable resizing of windows. In some embodiments, a stationary input (e.g., a double click) on an edge of the window causes

the edge of the window to move to a corresponding edge of the display area. As such, a dimension of the window expands in one direction while other edges of the window maintain their positions. In some embodiments, a stationary input (e.g., a double click) on a corner of the window causes the edges that intersect the window to move to a corresponding edges of the display area. As such, a first dimension of the window expands in a first direction and a second dimension of the window expands in a second direction while other edges of the window maintain their positions.

**[0032]** Described below are devices and methods that provide tabbed window functionality. In some embodiments, the operating system provides tabbed window functionality for applications without native tab functionality. In some embodiments, while the tabbed functionality is active, open windows are resized to a same size and stacked on top of one another such that the foreground window is displayed on the top of the stack. According to some embodiments, tabs corresponding to each of the windows in the stack are displayed within a virtual tab bar superimposed on the top window of the stack by the operating system. For example, if another tab is selected within the tab bar, a window associated with selected tab is moved to the top of the stack of windows. In some embodiments, the application is not aware of the fact that its windows are being displayed in a single tabbed window. According to some embodiments, the application is able to perform operations with respect to the windows as it normally would, treating them as though they were just stacked on top of each other.

**[0033]** Below, Figures 1A-1B, 2-3, and 4A-4B provide a description of example devices. Figures 5A-5MMM, 6A-6Y, and 7A-7R illustrate example user interfaces for window manipulation and management. Figures 8A-8E illustrate a flow diagram of a method of pairing edges of windows. Figures 9A-9D illustrate a flow diagram of a method of resizing windows. Figures 10A-10C illustrate a flow diagram of a method of providing tabbed window functionality. The user interfaces in Figures 5A-5MMM, 6A-6Y, and 7A-7R are used to illustrate the processes in Figures 8A-8E, 9A-9D, and 10A-10C.

#### EXAMPLE DEVICES

**[0034]** Reference will now be made in detail to embodiments, examples of which are illustrated in the accompanying drawings. In the following detailed description, numerous specific details are set forth in order to provide a thorough understanding of the various

described embodiments. However, it will be apparent to one of ordinary skill in the art that the various described embodiments may be practiced without these specific details. In other instances, well-known methods, procedures, components, circuits, and networks have not been described in detail so as not to unnecessarily obscure aspects of the embodiments.

**[0035]** It will also be understood that, although the terms first, second, etc. are, in some instances, used herein to describe various elements, these elements should not be limited by these terms. These terms are only used to distinguish one element from another. For example, a first contact could be termed a second contact, and, similarly, a second contact could be termed a first contact, without departing from the scope of the various described embodiments. The first contact and the second contact are both contacts, but they are not the same contact, unless the context clearly indicates otherwise.

**[0036]** The terminology used in the description of the various described embodiments herein is for the purpose of describing particular embodiments only and is not intended to be limiting. As used in the description of the various described embodiments and the appended claims, the singular forms “a,” “an,” and “the” are intended to include the plural forms as well, unless the context clearly indicates otherwise. It will also be understood that the term “and/or” as used herein refers to and encompasses any and all possible combinations of one or more of the associated listed items. It will be further understood that the terms “includes,” “including,” “comprises,” and/or “comprising,” when used in this specification, specify the presence of stated features, integers, steps, operations, elements, and/or components, but do not preclude the presence or addition of one or more other features, integers, steps, operations, elements, components, and/or groups thereof.

**[0037]** As used herein, the term “if” is, optionally, construed to mean “when” or “upon” or “in response to determining” or “in response to detecting,” depending on the context. Similarly, the phrase “if it is determined” or “if [a stated condition or event] is detected” is, optionally, construed to mean “upon determining” or “in response to determining” or “upon detecting [the stated condition or event]” or “in response to detecting [the stated condition or event],” depending on the context.

**[0038]** Embodiments of electronic devices, user interfaces for such devices, and associated processes for using such devices are described. In some embodiments, the device is a portable communications device, such as a mobile telephone, that also contains other

functions, such as PDA and/or music player functions. Example embodiments of portable multifunction devices include, without limitation, the iPhone®, iPod Touch®, and iPad® devices from Apple Inc. of Cupertino, California. Other portable electronic devices, such as laptops or tablet computers with touch-sensitive surfaces (e.g., touch-screen displays and/or touchpads), are, optionally, used. It should also be understood that, in some embodiments, the device is not a portable communications device, but is a desktop computer with a touch-sensitive surface (e.g., a touch-screen display and/or a touchpad).

**[0039]** In the discussion that follows, an electronic device that includes a display and a touch-sensitive surface is described. It should be understood, however, that the electronic device optionally includes one or more other physical user-interface devices, such as a physical keyboard, a mouse and/or a joystick.

**[0040]** The device typically supports a variety of applications, such as one or more of the following: a drawing application, a presentation application, a word processing application, a website creation application, a disk authoring application, a spreadsheet application, a gaming application, a telephone application, a video conferencing application, an e-mail application, an instant messaging application, a workout support application, a photo management application, a digital camera application, a digital video camera application, a web browsing application, a digital music player application, and/or a digital video player application.

**[0041]** The various applications that are executed on the device optionally use at least one common physical user-interface device, such as the touch-sensitive surface. One or more functions of the touch-sensitive surface as well as corresponding information displayed on the device are, optionally, adjusted and/or varied from one application to the next and/or within a respective application. In this way, a common physical architecture (such as the touch-sensitive surface) of the device optionally supports the variety of applications with user interfaces that are intuitive and transparent to the user.

**[0042]** Attention is now directed toward embodiments of portable devices with touch-sensitive displays. Figure 1A is a block diagram illustrating portable multifunction device 100 with touch-sensitive display system 112 in accordance with some embodiments. Touch-sensitive display system 112 is sometimes called a “touch screen” for convenience, and is sometimes simply called a touch-sensitive display. Device 100 includes memory 102 (which

optionally includes one or more computer readable storage mediums), memory controller 122, one or more processing units (CPUs) 120, peripherals interface 118, RF circuitry 108, audio circuitry 110, speaker 111, microphone 113, input/output (I/O) subsystem 106, other input or control devices 116, and external port 124. Device 100 optionally includes one or more optical sensors 164. Device 100 optionally includes one or more intensity sensors 165 for detecting intensity of contacts on device 100 (e.g., a touch-sensitive surface such as touch-sensitive display system 112 of device 100). Device 100 optionally includes one or more tactile output generators 163 for generating tactile outputs on device 100 (e.g., generating tactile outputs on a touch-sensitive surface such as touch-sensitive display system 112 of device 100 or touchpad 355 of device 300). These components optionally communicate over one or more communication buses or signal lines 103.

**[0043]** As used in the specification and claims, the term “tactile output” refers to physical displacement of a device relative to a previous position of the device, physical displacement of a component (e.g., a touch-sensitive surface) of a device relative to another component (e.g., housing) of the device, or displacement of the component relative to a center of mass of the device that will be detected by a user with the user’s sense of touch. For example, in situations where the device or the component of the device is in contact with a surface of a user that is sensitive to touch (e.g., a finger, palm, or other part of a user’s hand), the tactile output generated by the physical displacement will be interpreted by the user as a tactile sensation corresponding to a perceived change in physical characteristics of the device or the component of the device. For example, movement of a touch-sensitive surface (e.g., a touch-sensitive display or trackpad) is, optionally, interpreted by the user as a “down click” or “up click” of a physical actuator button. In some cases, a user will feel a tactile sensation such as an “down click” or “up click” even when there is no movement of a physical actuator button associated with the touch-sensitive surface that is physically pressed (e.g., displaced) by the user’s movements. As another example, movement of the touch-sensitive surface is, optionally, interpreted or sensed by the user as “roughness” of the touch-sensitive surface, even when there is no change in smoothness of the touch-sensitive surface. While such interpretations of touch by a user will be subject to the individualized sensory perceptions of the user, there are many sensory perceptions of touch that are common to a large majority of users. Thus, when a tactile output is described as corresponding to a particular sensory perception of a user (e.g., an “up click,” a “down click,” “roughness”), unless otherwise

stated, the generated tactile output corresponds to physical displacement of the device or a component thereof that will generate the described sensory perception for a typical (or average) user.

**[0044]** It should be appreciated that device 100 is only one example of a portable multifunction device, and that device 100 optionally has more or fewer components than shown, optionally combines two or more components, or optionally has a different configuration or arrangement of the components. The various components shown in Figure 1A are implemented in hardware, software, firmware, or a combination thereof, including one or more signal processing and/or application specific integrated circuits.

**[0045]** Memory 102 optionally includes high-speed random access memory and optionally also includes non-volatile memory, such as one or more magnetic disk storage devices, flash memory devices, or other non-volatile solid-state memory devices. Access to memory 102 by other components of device 100, such as CPU(s) 120 and the peripherals interface 118, is, optionally, controlled by memory controller 122.

**[0046]** Peripherals interface 118 can be used to couple input and output peripherals of the device to CPU(s) 120 and memory 102. The one or more processors 120 run or execute various software programs and/or sets of instructions stored in memory 102 to perform various functions for device 100 and to process data.

**[0047]** In some embodiments, peripherals interface 118, CPU(s) 120, and memory controller 122 are, optionally, implemented on a single chip, such as chip 104. In some other embodiments, they are, optionally, implemented on separate chips.

**[0048]** RF (radio frequency) circuitry 108 receives and sends RF signals, also called electromagnetic signals. RF circuitry 108 converts electrical signals to/from electromagnetic signals and communicates with communications networks and other communications devices via the electromagnetic signals. RF circuitry 108 optionally includes well-known circuitry for performing these functions, including but not limited to an antenna system, an RF transceiver, one or more amplifiers, a tuner, one or more oscillators, a digital signal processor, a CODEC chipset, a subscriber identity module (SIM) card, memory, and so forth. RF circuitry 108 optionally communicates with networks, such as the Internet, also referred to as the World Wide Web (WWW), an intranet and/or a wireless network, such as a cellular telephone network, a wireless local area network (LAN) and/or a metropolitan area network (MAN),

and other devices by wireless communication. The wireless communication optionally uses any of a plurality of communications standards, protocols and technologies, including but not limited to Global System for Mobile Communications (GSM), Enhanced Data GSM Environment (EDGE), high-speed downlink packet access (HSDPA), high-speed uplink packet access (HSUPA), Evolution, Data-Only (EV-DO), HSPA, HSPA+, Dual-Cell HSPA (DC-HSPDA), long term evolution (LTE), near field communication (NFC), wideband code division multiple access (W-CDMA), code division multiple access (CDMA), time division multiple access (TDMA), Bluetooth, Wireless Fidelity (Wi-Fi) (e.g., IEEE 802.11a, IEEE 802.11ac, IEEE 802.11ax, IEEE 802.11b, IEEE 802.11g and/or IEEE 802.11n), voice over Internet Protocol (VoIP), Wi-MAX, a protocol for e-mail (e.g., Internet message access protocol (IMAP) and/or post office protocol (POP)), instant messaging (e.g., extensible messaging and presence protocol (XMPP), Session Initiation Protocol for Instant Messaging and Presence Leveraging Extensions (SIMPLE), Instant Messaging and Presence Service (IMPS)), and/or Short Message Service (SMS), or any other suitable communication protocol, including communication protocols not yet developed as of the filing date of this document.

**[0049]** Audio circuitry 110, speaker 111, and microphone 113 provide an audio interface between a user and device 100. Audio circuitry 110 receives audio data from peripherals interface 118, converts the audio data to an electrical signal, and transmits the electrical signal to speaker 111. Speaker 111 converts the electrical signal to human-audible sound waves. Audio circuitry 110 also receives electrical signals converted by microphone 113 from sound waves. Audio circuitry 110 converts the electrical signal to audio data and transmits the audio data to peripherals interface 118 for processing. Audio data is, optionally, retrieved from and/or transmitted to memory 102 and/or RF circuitry 108 by peripherals interface 118. In some embodiments, audio circuitry 110 also includes a headset jack (e.g., 212, Figure 2). The headset jack provides an interface between audio circuitry 110 and removable audio input/output peripherals, such as output-only headphones or a headset with both output (e.g., a headphone for one or both ears) and input (e.g., a microphone).

**[0050]** I/O subsystem 106 couples input/output peripherals on device 100, such as touch-sensitive display system 112 and other input or control devices 116, with peripherals interface 118. I/O subsystem 106 optionally includes display controller 156, optical sensor controller 158, intensity sensor controller 159, haptic feedback controller 161, and one or

more input controllers 160 for other input or control devices. The one or more input controllers 160 receive/send electrical signals from/to other input or control devices 116. The other input or control devices 116 optionally include physical buttons (e.g., push buttons, rocker buttons, etc.), dials, slider switches, joysticks, click wheels, and so forth. In some alternate embodiments, input controller(s) 160 are, optionally, coupled with any (or none) of the following: a keyboard, infrared port, USB port, stylus, and/or a pointer device such as a mouse. The one or more buttons (e.g., 208, Figure 2) optionally include an up/down button for volume control of speaker 111 and/or microphone 113. The one or more buttons optionally include a push button (e.g., 206, Figure 2).

**[0051]** Touch-sensitive display system 112 provides an input interface and an output interface between the device and a user. Display controller 156 receives and/or sends electrical signals from/to touch-sensitive display system 112. Touch-sensitive display system 112 displays visual output to the user. The visual output optionally includes graphics, text, icons, video, and any combination thereof (collectively termed “graphics”). In some embodiments, some or all of the visual output corresponds to user-interface objects.

**[0052]** Touch-sensitive display system 112 has a touch-sensitive surface, sensor or set of sensors that accepts input from the user based on haptic/tactile contact. Touch-sensitive display system 112 and display controller 156 (along with any associated modules and/or sets of instructions in memory 102) detect contact (and any movement or breaking of the contact) on touch-sensitive display system 112 and converts the detected contact into interaction with user-interface objects (e.g., one or more soft keys, icons, web pages or images) that are displayed on touch-sensitive display system 112. In an example embodiment, a point of contact between touch-sensitive display system 112 and the user corresponds to a finger of the user or a stylus.

**[0053]** Touch-sensitive display system 112 optionally uses LCD (liquid crystal display) technology, LPD (light emitting polymer display) technology, or LED (light emitting diode) technology, although other display technologies are used in other embodiments. Touch-sensitive display system 112 and display controller 156 optionally detect contact and any movement or breaking thereof using any of a plurality of touch sensing technologies now known or later developed, including but not limited to capacitive, resistive, infrared, and surface acoustic wave technologies, as well as other proximity sensor arrays or other elements



for determining one or more points of contact with touch-sensitive display system 112. In an example embodiment, projected mutual capacitance sensing technology is used, such as that found in the iPhone®, iPod Touch®, and iPad® from Apple Inc. of Cupertino, California.

**[0054]** Touch-sensitive display system 112 optionally has a video resolution in excess of 100 dpi. In some embodiments, the touch screen video resolution is in excess of 400 dpi (e.g., 500 dpi, 800 dpi, or greater). The user optionally makes contact with touch-sensitive display system 112 using any suitable object or appendage, such as a stylus, a finger, and so forth. In some embodiments, the user interface is designed to work with finger-based contacts and gestures, which can be less precise than stylus-based input due to the larger area of contact of a finger on the touch screen. In some embodiments, the device translates the rough finger-based input into a precise pointer/cursor position or command for performing the actions desired by the user.

**[0055]** In some embodiments, in addition to the touch screen, device 100 optionally includes a touchpad (not shown) for activating or deactivating particular functions. In some embodiments, the touchpad is a touch-sensitive area of the device that, unlike the touch screen, does not display visual output. The touchpad is, optionally, a touch-sensitive surface that is separate from touch-sensitive display system 112 or an extension of the touch-sensitive surface formed by the touch screen.

**[0056]** Device 100 also includes power system 162 for powering the various components. Power system 162 optionally includes a power management system, one or more power sources (e.g., battery, alternating current (AC)), a recharging system, a power failure detection circuit, a power converter or inverter, a power status indicator (e.g., a light-emitting diode (LED)) and any other components associated with the generation, management and distribution of power in portable devices.

**[0057]** Device 100 optionally also includes one or more optical sensors 164. Figure 1A shows an optical sensor coupled with optical sensor controller 158 in I/O subsystem 106. Optical sensor(s) 164 optionally include charge-coupled device (CCD) or complementary metal-oxide semiconductor (CMOS) phototransistors. Optical sensor(s) 164 receive light from the environment, projected through one or more lens, and converts the light to data representing an image. In conjunction with imaging module 143 (also called a camera module), optical sensor(s) 164 optionally capture still images and/or video. In some

embodiments, an optical sensor is located on the back of device 100, opposite touch-sensitive display system 112 on the front of the device, so that the touch screen is enabled for use as a viewfinder for still and/or video image acquisition. In some embodiments, another optical sensor is located on the front of the device so that the user's image is obtained (e.g., for selfies, for videoconferencing while the user views the other video conference participants on the touch screen, etc.).

**[0058]** Device 100 optionally also includes one or more contact intensity sensors 165. Figure 1A shows a contact intensity sensor coupled with intensity sensor controller 159 in I/O subsystem 106. Contact intensity sensor(s) 165 optionally include one or more piezoresistive strain gauges, capacitive force sensors, electric force sensors, piezoelectric force sensors, optical force sensors, capacitive touch-sensitive surfaces, or other intensity sensors (e.g., sensors used to measure the force (or pressure) of a contact on a touch-sensitive surface). Contact intensity sensor(s) 165 receive contact intensity information (e.g., pressure information or a proxy for pressure information) from the environment. In some embodiments, at least one contact intensity sensor is collocated with, or proximate to, a touch-sensitive surface (e.g., touch-sensitive display system 112). In some embodiments, at least one contact intensity sensor is located on the back of device 100, opposite touch-screen display system 112 which is located on the front of device 100.

**[0059]** Device 100 optionally also includes one or more proximity sensors 166. Figure 1A shows proximity sensor 166 coupled with peripherals interface 118. Alternately, proximity sensor 166 is coupled with input controller 160 in I/O subsystem 106. In some embodiments, the proximity sensor turns off and disables touch-sensitive display system 112 when the multifunction device is placed near the user's ear (e.g., when the user is making a phone call).

**[0060]** Device 100 optionally also includes one or more tactile output generators 163. Figure 1A shows a tactile output generator coupled with haptic feedback controller 161 in I/O subsystem 106. Tactile output generator(s) 163 optionally include one or more electroacoustic devices such as speakers or other audio components and/or electromechanical devices that convert energy into linear motion such as a motor, solenoid, electroactive polymer, piezoelectric actuator, electrostatic actuator, or other tactile output generating component (e.g., a component that converts electrical signals into tactile outputs on the device). Tactile

output generator(s) 163 receive tactile feedback generation instructions from haptic feedback module 133 and generates tactile outputs on device 100 that are capable of being sensed by a user of device 100. In some embodiments, at least one tactile output generator is collocated with, or proximate to, a touch-sensitive surface (e.g., touch-sensitive display system 112) and, optionally, generates a tactile output by moving the touch-sensitive surface vertically (e.g., in/out of a surface of device 100) or laterally (e.g., back and forth in the same plane as a surface of device 100). In some embodiments, at least one tactile output generator sensor is located on the back of device 100, opposite touch-sensitive display system 112, which is located on the front of device 100.

**[0061]** Device 100 optionally also includes one or more accelerometers 167, gyroscopes 168, and/or magnetometers 169 (e.g., as part of an inertial measurement unit (IMU)) for obtaining information concerning the position (e.g., attitude) of the device. Figure 1A shows sensors 167, 168, and 169 coupled with peripherals interface 118. Alternately, sensors 167, 168, and 169 are, optionally, coupled with an input controller 160 in I/O subsystem 106. In some embodiments, information is displayed on the touch-screen display in a portrait view or a landscape view based on an analysis of data received from the one or more accelerometers. Device 100 optionally includes a GPS (or GLONASS or other global navigation system) receiver (not shown) for obtaining information concerning the location of device 100.

**[0062]** In some embodiments, the software components stored in memory 102 include operating system 126, communication module (or set of instructions) 128, contact/motion module (or set of instructions) 130, graphics module (or set of instructions) 132, haptic feedback module (or set of instructions) 133, text input module (or set of instructions) 134, Global Positioning System (GPS) module (or set of instructions) 135, and applications (or sets of instructions) 136. Furthermore, in some embodiments, memory 102 stores device/global internal state 157, as shown in Figures 1A and 3. Device/global internal state 157 includes one or more of: active application state, indicating which applications, if any, are currently active; display state, indicating what applications, views or other information occupy various regions of touch-sensitive display system 112; sensor state, including information obtained from the device's various sensors and other input or control devices 116; and location and/or positional information concerning the device's location and/or attitude.

**[0063]** Operating system 126 (e.g., iOS, Darwin, RTXC, LINUX, UNIX, OS X, WINDOWS, or an embedded operating system such as VxWorks) includes various software components and/or drivers for controlling and managing general system tasks (e.g., memory management, storage device control, power management, etc.) and facilitates communication between various hardware and software components.

**[0064]** Communication module 128 facilitates communication with other devices over one or more external ports 124 and also includes various software components for handling data received by RF circuitry 108 and/or external port 124. External port 124 (e.g., Universal Serial Bus (USB), FIREWIRE, etc.) is adapted for coupling directly to other devices or indirectly over a network (e.g., the Internet, wireless LAN, etc.). In some embodiments, the external port is a multi-pin (e.g., 30-pin) connector that is the same as, or similar to and/or compatible with the 30-pin connector used in some iPhone®, iPod Touch®, and iPad® devices from Apple Inc. of Cupertino, California. In some embodiments, the external port is a Lightning connector that is the same as, or similar to and/or compatible with the Lightning connector used in some iPhone®, iPod Touch®, and iPad® devices from Apple Inc. of Cupertino, California.

**[0065]** Contact/motion module 130 optionally detects contact with touch-sensitive display system 112 (in conjunction with display controller 156) and other touch-sensitive devices (e.g., a touchpad or physical click wheel). Contact/motion module 130 includes software components for performing various operations related to detection of contact (e.g., by a finger or by a stylus), such as determining if contact has occurred (e.g., detecting a finger-down event), determining an intensity of the contact (e.g., the force or pressure of the contact or a substitute for the force or pressure of the contact), determining if there is movement of the contact and tracking the movement across the touch-sensitive surface (e.g., detecting one or more finger-dragging events), and determining if the contact has ceased (e.g., detecting a finger-up event or a break in contact). Contact/motion module 130 receives contact data from the touch-sensitive surface. Determining movement of the point of contact, which is represented by a series of contact data, optionally includes determining speed (magnitude), velocity (magnitude and direction), and/or an acceleration (a change in magnitude and/or direction) of the point of contact. These operations are, optionally, applied to single contacts (e.g., one finger contacts or stylus contacts) or to multiple simultaneous contacts (e.g.,

“multitouch”/multiple finger contacts and/or stylus contacts). In some embodiments, contact/motion module 130 and display controller 156 detect contact on a touchpad.

**[0066]** Contact/motion module 130 optionally detects a gesture input by a user. Different gestures on the touch-sensitive surface have different contact patterns (e.g., different motions, timings, and/or intensities of detected contacts). Thus, a gesture is, optionally, detected by detecting a particular contact pattern. For example, detecting a finger tap gesture includes detecting a finger-down event followed by detecting a finger-up (lift off) event at the same position (or substantially the same position) as the finger-down event (e.g., at the position of an icon). As another example, detecting a finger swipe gesture on the touch-sensitive surface includes detecting a finger-down event followed by detecting one or more finger-dragging events, and subsequently followed by detecting a finger-up (lift off) event. Similarly, tap, swipe, drag, and other gestures are optionally detected for a stylus by detecting a particular contact pattern for the stylus.

**[0067]** Graphics module 132 includes various known software components for rendering and displaying graphics on touch-sensitive display system 112 or other display, including components for changing the visual impact (e.g., brightness, transparency, saturation, contrast or other visual property) of graphics that are displayed. As used herein, the term “graphics” includes any object that can be displayed to a user, including without limitation text, web pages, icons (such as user-interface objects including soft keys), digital images, videos, animations and the like.

**[0068]** In some embodiments, graphics module 132 stores data representing graphics to be used. Each graphic is, optionally, assigned a corresponding code. Graphics module 132 receives, from applications etc., one or more codes specifying graphics to be displayed along with, if necessary, coordinate data and other graphic property data, and then generates screen image data to output to display controller 156.

**[0069]** Haptic feedback module 133 includes various software components for generating instructions used by tactile output generator(s) 163 to produce tactile outputs at one or more locations on device 100 in response to user interactions with device 100.

**[0070]** Text input module 134, which is, optionally, a component of graphics module 132, provides soft keyboards for entering text in various applications (e.g., contacts 137, e-mail 140, IM 141, browser 147, and any other application that needs text input).

[0071] GPS module 135 determines the location of the device and provides this information for use in various applications (e.g., to telephone 138 for use in location-based dialing, to camera 143 as picture/video metadata, and to applications that provide location-based services such as weather widgets, local yellow page widgets, and map/navigation widgets).

[0072] Applications 136 optionally include the following modules (or sets of instructions), or a subset or superset thereof:

- contacts module 137 (sometimes called an address book or contact list);
- telephone module 138;
- video conferencing module 139;
- e-mail client module 140;
- instant messaging (IM) module 141;
- workout support module 142;
- camera module 143 for still and/or video images;
- image management module 144;
- browser module 147;
- calendar module 148;
- widget modules 149, which optionally include one or more of: weather widget 149-1, stocks widget 149-2, calculator widget 149-3, alarm clock widget 149-4, dictionary widget 149-5, and other widgets obtained by the user, as well as user-created widgets 149-6;
- widget creator module 150 for making user-created widgets 149-6;
- search module 151;
- video and music player module 152, which is, optionally, made up of a video player module and a music player module;
- notes module 153;
- map module 154; and/or

- online video module 155.

**[0073]** Examples of other applications 136 that are, optionally, stored in memory 102 include other word processing applications, other image editing applications, drawing applications, presentation applications, JAVA-enabled applications, encryption, digital rights management, voice recognition, and voice replication.

**[0074]** In conjunction with touch-sensitive display system 112, display controller 156, contact module 130, graphics module 132, and text input module 134, contacts module 137 includes executable instructions to manage an address book or contact list (e.g., stored in application internal state 192 of contacts module 137 in memory 102 or memory 370), including: adding name(s) to the address book; deleting name(s) from the address book; associating telephone number(s), e-mail address(es), physical address(es) or other information with a name; associating an image with a name; categorizing and sorting names; providing telephone numbers and/or e-mail addresses to initiate and/or facilitate communications by telephone 138, video conference 139, e-mail 140, or IM 141; and so forth.

**[0075]** In conjunction with RF circuitry 108, audio circuitry 110, speaker 111, microphone 113, touch-sensitive display system 112, display controller 156, contact module 130, graphics module 132, and text input module 134, telephone module 138 includes executable instructions to enter a sequence of characters corresponding to a telephone number, access one or more telephone numbers in address book 137, modify a telephone number that has been entered, dial a respective telephone number, conduct a conversation and disconnect or hang up when the conversation is completed. As noted above, the wireless communication optionally uses any of a plurality of communications standards, protocols and technologies.

**[0076]** In conjunction with RF circuitry 108, audio circuitry 110, speaker 111, microphone 113, touch-sensitive display system 112, display controller 156, optical sensor(s) 164, optical sensor controller 158, contact module 130, graphics module 132, text input module 134, contact list 137, and telephone module 138, videoconferencing module 139 includes executable instructions to initiate, conduct, and terminate a video conference between a user and one or more other participants in accordance with user instructions.

**[0077]** In conjunction with RF circuitry 108, touch-sensitive display system 112, display controller 156, contact module 130, graphics module 132, and text input module 134,

e-mail client module 140 includes executable instructions to create, send, receive, and manage e-mail in response to user instructions. In conjunction with image management module 144, e-mail client module 140 makes it very easy to create and send e-mails with still or video images taken with camera module 143.

**[0078]** In conjunction with RF circuitry 108, touch-sensitive display system 112, display controller 156, contact module 130, graphics module 132, and text input module 134, the instant messaging module 141 includes executable instructions to enter a sequence of characters corresponding to an instant message, to modify previously entered characters, to transmit a respective instant message (for example, using a Short Message Service (SMS) or Multimedia Message Service (MMS) protocol for telephony-based instant messages or using XMPP, SIMPLE, Apple Push Notification Service (APNs) or IMPS for Internet-based instant messages), to receive instant messages and to view received instant messages. In some embodiments, transmitted and/or received instant messages optionally include graphics, photos, audio files, video files and/or other attachments as are supported in a MMS and/or an Enhanced Messaging Service (EMS). As used herein, “instant messaging” refers to both telephony-based messages (e.g., messages sent using SMS or MMS) and Internet-based messages (e.g., messages sent using XMPP, SIMPLE, APNs, or IMPS).

**[0079]** In conjunction with RF circuitry 108, touch-sensitive display system 112, display controller 156, contact module 130, graphics module 132, text input module 134, GPS module 135, map module 154, and music player module 146, workout support module 142 includes executable instructions to create workouts (e.g., with time, distance, and/or calorie burning goals); communicate with workout sensors (in sports devices and smart watches); receive workout sensor data; calibrate sensors used to monitor a workout; select and play music for a workout; and display, store and transmit workout data.

**[0080]** In conjunction with touch-sensitive display system 112, display controller 156, optical sensor(s) 164, optical sensor controller 158, contact module 130, graphics module 132, and image management module 144, camera module 143 includes executable instructions to capture still images or video (including a video stream) and store them into memory 102, modify characteristics of a still image or video, and/or delete a still image or video from memory 102.



**[0081]** In conjunction with touch-sensitive display system 112, display controller 156, contact module 130, graphics module 132, text input module 134, and camera module 143, image management module 144 includes executable instructions to arrange, modify (e.g., edit), or otherwise manipulate, label, delete, present (e.g., in a digital slide show or album), and store still and/or video images.

**[0082]** In conjunction with RF circuitry 108, touch-sensitive display system 112, display system controller 156, contact module 130, graphics module 132, and text input module 134, browser module 147 includes executable instructions to browse the Internet in accordance with user instructions, including searching, linking to, receiving, and displaying web pages or portions thereof, as well as attachments and other files linked to web pages.

**[0083]** In conjunction with RF circuitry 108, touch-sensitive display system 112, display system controller 156, contact module 130, graphics module 132, text input module 134, e-mail client module 140, and browser module 147, calendar module 148 includes executable instructions to create, display, modify, and store calendars and data associated with calendars (e.g., calendar entries, to do lists, etc.) in accordance with user instructions.

**[0084]** In conjunction with RF circuitry 108, touch-sensitive display system 112, display system controller 156, contact module 130, graphics module 132, text input module 134, and browser module 147, widget modules 149 are mini-applications that are, optionally, downloaded and used by a user (e.g., weather widget 149-1, stocks widget 149-2, calculator widget 149-3, alarm clock widget 149-4, and dictionary widget 149-5) or created by the user (e.g., user-created widget 149-6). In some embodiments, a widget includes an HTML (Hypertext Markup Language) file, a CSS (Cascading Style Sheets) file, and a JavaScript file. In some embodiments, a widget includes an XML (Extensible Markup Language) file and a JavaScript file (e.g., Yahoo! Widgets).

**[0085]** In conjunction with RF circuitry 108, touch-sensitive display system 112, display system controller 156, contact module 130, graphics module 132, text input module 134, and browser module 147, the widget creator module 150 includes executable instructions to create widgets (e.g., turning a user-specified portion of a web page into a widget).

**[0086]** In conjunction with touch-sensitive display system 112, display system controller 156, contact module 130, graphics module 132, and text input module 134, search module 151 includes executable instructions to search for text, music, sound, image, video,

and/or other files in memory 102 that match one or more search criteria (e.g., one or more user-specified search terms) in accordance with user instructions.

**[0087]** In conjunction with touch-sensitive display system 112, display system controller 156, contact module 130, graphics module 132, audio circuitry 110, speaker 111, RF circuitry 108, and browser module 147, video and music player module 152 includes executable instructions that allow the user to download and play back recorded music and other sound files stored in one or more file formats, such as MP3 or AAC files, and executable instructions to display, present or otherwise play back videos (e.g., on touch-sensitive display system 112, or on an external display connected wirelessly or via external port 124). In some embodiments, device 100 optionally includes the functionality of an MP3 player, such as an iPod (trademark of Apple Inc.).

**[0088]** In conjunction with touch-sensitive display system 112, display controller 156, contact module 130, graphics module 132, and text input module 134, notes module 153 includes executable instructions to create and manage notes, to do lists, and the like in accordance with user instructions.

**[0089]** In conjunction with RF circuitry 108, touch-sensitive display system 112, display system controller 156, contact module 130, graphics module 132, text input module 134, GPS module 135, and browser module 147, map module 154 includes executable instructions to receive, display, modify, and store maps and data associated with maps (e.g., driving directions; data on stores and other points of interest at or near a particular location; and other location-based data) in accordance with user instructions.

**[0090]** In conjunction with touch-sensitive display system 112, display system controller 156, contact module 130, graphics module 132, audio circuitry 110, speaker 111, RF circuitry 108, text input module 134, e-mail client module 140, and browser module 147, online video module 155 includes executable instructions that allow the user to access, browse, receive (e.g., by streaming and/or download), play back (e.g., on the touch screen 112, or on an external display connected wirelessly or via external port 124), send an e-mail with a link to a particular online video, and otherwise manage online videos in one or more file formats, such as H.264. In some embodiments, instant messaging module 141, rather than e-mail client module 140, is used to send a link to a particular online video.

**[0091]** Each of the above identified modules and applications correspond to a set of executable instructions for performing one or more functions described above and the methods described in this application (e.g., the computer-implemented methods and other information processing methods described herein). These modules (i.e., sets of instructions) need not be implemented as separate software programs, procedures or modules, and thus various subsets of these modules are, optionally, combined or otherwise re-arranged in various embodiments. In some embodiments, memory 102 optionally stores a subset of the modules and data structures identified above. Furthermore, memory 102 optionally stores additional modules and data structures not described above.

**[0092]** In some embodiments, device 100 is a device where operation of a predefined set of functions on the device is performed exclusively through a touch screen and/or a touchpad. By using a touch screen and/or a touchpad as the primary input control device for operation of device 100, the number of physical input control devices (such as push buttons, dials, and the like) on device 100 is, optionally, reduced.

**[0093]** The predefined set of functions that are performed exclusively through a touch screen and/or a touchpad optionally include navigation between user interfaces. In some embodiments, the touchpad, when touched by the user, navigates device 100 to a main, home, or root menu from any user interface that is displayed on device 100. In such embodiments, a “menu button” is implemented using a touchpad. In some other embodiments, the menu button is a physical push button or other physical input control device instead of a touchpad.

**[0094]** Figure 1B is a block diagram illustrating example components for event handling in accordance with some embodiments. In some embodiments, memory 102 (in Figures 1A) or 370 (Figure 3) includes event sorter 170 (e.g., in operating system 126) and a respective application 136-1 (e.g., any of the aforementioned applications 136, 137-155, 380-390).

**[0095]** Event sorter 170 receives event information and determines the application 136-1 and application view 191 of application 136-1 to which to deliver the event information. Event sorter 170 includes event monitor 171 and event dispatcher module 174. In some embodiments, application 136-1 includes application internal state 192, which indicates the current application view(s) displayed on touch-sensitive display system 112 when the application is active or executing. In some embodiments, device/global internal state

157 is used by event sorter 170 to determine which application(s) is (are) currently active, and application internal state 192 is used by event sorter 170 to determine application views 191 to which to deliver event information.

**[0096]** In some embodiments, application internal state 192 includes additional information, such as one or more of: resume information to be used when application 136-1 resumes execution, user interface state information that indicates information being displayed or that is ready for display by application 136-1, a state queue for enabling the user to go back to a prior state or view of application 136-1, and a redo/undo queue of previous actions taken by the user.

**[0097]** Event monitor 171 receives event information from peripherals interface 118. Event information includes information about a sub-event (e.g., a user touch on touch-sensitive display system 112, as part of a multi-touch gesture). Peripherals interface 118 transmits information it receives from I/O subsystem 106 or a sensor, such as proximity sensor 166, accelerometer(s) 167, gyroscope(s) 168, magnetometer(s) 169, and/or microphone 113 (through audio circuitry 110). Information that peripherals interface 118 receives from I/O subsystem 106 includes information from touch-sensitive display system 112 or a touch-sensitive surface.

**[0098]** In some embodiments, event monitor 171 sends requests to the peripherals interface 118 at predetermined intervals. In response, peripherals interface 118 transmits event information. In other embodiments, peripheral interface 118 transmits event information only when there is a significant event (e.g., receiving an input above a predetermined noise threshold and/or for more than a predetermined duration).

**[0099]** In some embodiments, event sorter 170 also includes a hit view determination module 172 and/or an active event recognizer determination module 173.

**[00100]** Hit view determination module 172 provides software procedures for determining where a sub-event has taken place within one or more views, when touch-sensitive display system 112 displays more than one view. Views are made up of controls and other elements that a user can see on the display.

**[00101]** Another aspect of the user interface associated with an application is a set of views, sometimes herein called application views or user interface windows, in which

information is displayed and touch-based gestures occur. The application views (of a respective application) in which a touch is detected optionally correspond to programmatic levels within a programmatic or view hierarchy of the application. For example, the lowest level view in which a touch is detected is, optionally, called the hit view, and the set of events that are recognized as proper inputs are, optionally, determined based, at least in part, on the hit view of the initial touch that begins a touch-based gesture.

**[00102]** Hit view determination module 172 receives information related to sub-events of a touch-based gesture. When an application has multiple views organized in a hierarchy, hit view determination module 172 identifies a hit view as the lowest view in the hierarchy which should handle the sub-event. In most circumstances, the hit view is the lowest level view in which an initiating sub-event occurs (i.e., the first sub-event in the sequence of sub-events that form an event or potential event). Once the hit view is identified by the hit view determination module, the hit view typically receives all sub-events related to the same touch or input source for which it was identified as the hit view.

**[00103]** Active event recognizer determination module 173 determines which view or views within a view hierarchy should receive a particular sequence of sub-events. In some embodiments, active event recognizer determination module 173 determines that only the hit view should receive a particular sequence of sub-events. In other embodiments, active event recognizer determination module 173 determines that all views that include the physical location of a sub-event are actively involved views, and therefore determines that all actively involved views should receive a particular sequence of sub-events. In other embodiments, even if touch sub-events were entirely confined to the area associated with one particular view, views higher in the hierarchy would still remain as actively involved views.

**[00104]** Event dispatcher module 174 dispatches the event information to an event recognizer (e.g., event recognizer 180). In embodiments including active event recognizer determination module 173, event dispatcher module 174 delivers the event information to an event recognizer determined by active event recognizer determination module 173. In some embodiments, event dispatcher module 174 stores in an event queue the event information, which is retrieved by a respective event receiver module 182.

**[00105]** In some embodiments, operating system 126 includes event sorter 170. Alternatively, application 136-1 includes event sorter 170. In yet other embodiments, event

sorter 170 is a stand-alone module, or a part of another module stored in memory 102, such as contact/motion module 130.

**[00106]** In some embodiments, application 136-1 includes a plurality of event handlers 190 and one or more application views 191, each of which includes instructions for handling touch events that occur within a respective view of the application's user interface. Each application view 191 of the application 136-1 includes one or more event recognizers 180. Typically, a respective application view 191 includes a plurality of event recognizers 180. In other embodiments, one or more of event recognizers 180 are part of a separate module, such as a user interface kit (not shown) or a higher level object from which application 136-1 inherits methods and other properties. In some embodiments, a respective event handler 190 includes one or more of: data updater 176, object updater 177, GUI updater 178, and/or event data 179 received from event sorter 170. Event handler 190 optionally utilizes or calls data updater 176, object updater 177 or GUI updater 178 to update the application internal state 192. Alternatively, one or more of the application views 191 includes one or more respective event handlers 190. Also, in some embodiments, one or more of data updater 176, object updater 177, and GUI updater 178 are included in a respective application view 191.

**[00107]** A respective event recognizer 180 receives event information (e.g., event data 179) from event sorter 170, and identifies an event from the event information. Event recognizer 180 includes event receiver 182 and event comparator 184. In some embodiments, event recognizer 180 also includes at least a subset of: metadata 183, and event delivery instructions 188 (which optionally include sub-event delivery instructions).

**[00108]** Event receiver 182 receives event information from event sorter 170. The event information includes information about a sub-event, for example, a touch or a touch movement. Depending on the sub-event, the event information also includes additional information, such as location of the sub-event. When the sub-event concerns motion of a touch, the event information optionally also includes speed and direction of the sub-event. In some embodiments, events include rotation of the device from one orientation to another (e.g., from a portrait orientation to a landscape orientation, or vice versa), and the event information includes corresponding information about the current orientation (also called device attitude) of the device.

**[00109]** Event comparator 184 compares the event information to predefined event or sub-event definitions and, based on the comparison, determines an event or sub-event, or determines or updates the state of an event or sub-event. In some embodiments, event comparator 184 includes event definitions 186. Event definitions 186 contain definitions of events (e.g., predefined sequences of sub-events), for example, event 1 (187-1), event 2 (187-2), and others. In some embodiments, sub-events in an event 187 include, for example, touch begin, touch end, touch movement, touch cancellation, and multiple touching. In one example, the definition for event 1 (187-1) is a double tap on a displayed object. The double tap, for example, comprises a first touch (touch begin) on the displayed object for a predetermined phase, a first lift-off (touch end) for a predetermined phase, a second touch (touch begin) on the displayed object for a predetermined phase, and a second lift-off (touch end) for a predetermined phase. In another example, the definition for event 2 (187-2) is a dragging on a displayed object. The dragging, for example, comprises a touch (or contact) on the displayed object for a predetermined phase, a movement of the touch across touch-sensitive display system 112, and lift-off of the touch (touch end). In some embodiments, the event also includes information for one or more associated event handlers 190.

**[00110]** In some embodiments, event definition 187 includes a definition of an event for a respective user-interface object. In some embodiments, event comparator 184 performs a hit test to determine which user-interface object is associated with a sub-event. For example, in an application view in which three user-interface objects are displayed on touch-sensitive display system 112, when a touch is detected on touch-sensitive display system 112, event comparator 184 performs a hit test to determine which of the three user-interface objects is associated with the touch (sub-event). If each displayed object is associated with a respective event handler 190, the event comparator uses the result of the hit test to determine which event handler 190 should be activated. For example, event comparator 184 selects an event handler associated with the sub-event and the object triggering the hit test.

**[00111]** In some embodiments, the definition for a respective event 187 also includes delayed actions that delay delivery of the event information until after it has been determined whether the sequence of sub-events does or does not correspond to the event recognizer's event type.

**[00112]** When a respective event recognizer 180 determines that the series of sub-events do not match any of the events in event definitions 186, the respective event recognizer 180 enters an event impossible, event failed, or event ended state, after which it disregards subsequent sub-events of the touch-based gesture. In this situation, other event recognizers, if any, that remain active for the hit view continue to track and process sub-events of an ongoing touch-based gesture.

**[00113]** In some embodiments, a respective event recognizer 180 includes metadata 183 with configurable properties, flags, and/or lists that indicate how the event delivery system should perform sub-event delivery to actively involved event recognizers. In some embodiments, metadata 183 includes configurable properties, flags, and/or lists that indicate how event recognizers interact, or are enabled to interact, with one another. In some embodiments, metadata 183 includes configurable properties, flags, and/or lists that indicate whether sub-events are delivered to varying levels in the view or programmatic hierarchy.

**[00114]** In some embodiments, a respective event recognizer 180 activates event handler 190 associated with an event when one or more particular sub-events of an event are recognized. In some embodiments, a respective event recognizer 180 delivers event information associated with the event to event handler 190. Activating an event handler 190 is distinct from sending (and deferred sending) sub-events to a respective hit view. In some embodiments, event recognizer 180 throws a flag associated with the recognized event, and event handler 190 associated with the flag catches the flag and performs a predefined process.

**[00115]** In some embodiments, event delivery instructions 188 include sub-event delivery instructions that deliver event information about a sub-event without activating an event handler. Instead, the sub-event delivery instructions deliver event information to event handlers associated with the series of sub-events or to actively involved views. Event handlers associated with the series of sub-events or with actively involved views receive the event information and perform a predetermined process.

**[00116]** In some embodiments, data updater 176 creates and updates data used in application 136-1. For example, data updater 176 updates the telephone number used in contacts module 137, or stores a video file used in video player module 145. In some embodiments, object updater 177 creates and updates objects used in application 136-1. For example, object updater 176 creates a new user-interface object or updates the position of a



user-interface object. GUI updater 178 updates the GUI. For example, GUI updater 178 prepares display information and sends it to graphics module 132 for display on a touch-sensitive display.

**[00117]** In some embodiments, event handler(s) 190 includes or has access to data updater 176, object updater 177, and GUI updater 178. In some embodiments, data updater 176, object updater 177, and GUI updater 178 are included in a single module of a respective application 136-1 or application view 191. In other embodiments, they are included in two or more software modules.

**[00118]** It shall be understood that the foregoing discussion regarding event handling of user touches on touch-sensitive displays also applies to other forms of user inputs to operate multifunction devices 100 with input-devices, not all of which are initiated on touch screens. For example, mouse movement and mouse button presses, optionally coordinated with single or multiple keyboard presses or holds; contact movements such as taps, drags, scrolls, etc., on touch-pads; pen stylus inputs; movement of the device; oral instructions; detected eye movements; biometric inputs; and/or any combination thereof are optionally utilized as inputs corresponding to sub-events which define an event to be recognized.

**[00119]** Figure 2 illustrates a portable multifunction device 100 having a touch screen (e.g., touch-sensitive display system 112, Figure 1A) in accordance with some embodiments. The touch screen optionally displays one or more graphics within user interface (UI) 200. In this embodiment, as well as others described below, a user is enabled to select one or more of the graphics by making a gesture on the graphics, for example, with one or more fingers 202 (not drawn to scale in the figure) or one or more styluses 203 (not drawn to scale in the figure). In some embodiments, selection of one or more graphics occurs when the user breaks contact with the one or more graphics. In some embodiments, the gesture optionally includes one or more taps, one or more swipes (from left to right, right to left, upward and/or downward) and/or a rolling of a finger (from right to left, left to right, upward and/or downward) that has made contact with device 100. In some implementations or circumstances, inadvertent contact with a graphic does not select the graphic. For example, a swipe gesture that sweeps over an application icon optionally does not select the corresponding application when the gesture corresponding to selection is a tap.

**[00120]** Device 100 optionally also includes one or more physical buttons, such as “home” or menu button 204. As described previously, menu button 204 is, optionally, used to navigate to any application 136 in a set of applications that are, optionally executed on device 100. Alternatively, in some embodiments, the menu button is implemented as a soft key in a GUI displayed on the touch-screen display.

**[00121]** In some embodiments, device 100 includes the touch-screen display, menu button 204, push button 206 for powering the device on/off and locking the device, volume adjustment button(s) 208, Subscriber Identity Module (SIM) card slot 210, head set jack 212, and docking/charging external port 124. Push button 206 is, optionally, used to turn the power on/off on the device by depressing the button and holding the button in the depressed state for a predefined time interval; to lock the device by depressing the button and releasing the button before the predefined time interval has elapsed; and/or to unlock the device or initiate an unlock process. In some embodiments, device 100 also accepts verbal input for activation or deactivation of some functions through microphone 113. Device 100 also, optionally, includes one or more contact intensity sensors 165 for detecting intensity of contacts on touch-sensitive display system 112 and/or one or more tactile output generators 163 for generating tactile outputs for a user of device 100.

**[00122]** Figure 3 is a block diagram of an example multifunction device with a display and a touch-sensitive surface in accordance with some embodiments. Device 300 need not be portable. In some embodiments, device 300 is a laptop computer, a desktop computer, a tablet computer, a multimedia player device, a navigation device, an educational device (such as a child’s learning toy), a gaming system, or a control device (e.g., a home or industrial controller). Device 300 typically includes one or more processing units (CPU’s) 310, one or more network or other communications interfaces 360, memory 370, and one or more communication buses 320 for interconnecting these components. Communication buses 320 optionally include circuitry (sometimes called a chipset) that interconnects and controls communications between system components. Device 300 includes input/output (I/O) interface 330 comprising display 340, which is typically a touch-screen display. I/O interface 330 also optionally includes a keyboard and/or mouse (or other pointing device) 350 and touchpad 355, tactile output generator 357 for generating tactile outputs on device 300 (e.g., similar to tactile output generator(s) 163 described above with reference to Figure 1A), sensors 359 (e.g., touch-sensitive, optical, contact intensity, proximity, acceleration, attitude,

and/or magnetic sensors similar to sensors 112, 164, 165, 166, 167, 168, and 169 described above with reference to Figure 1A). Memory 370 includes high-speed random access memory, such as DRAM, SRAM, DDR RAM or other random access solid state memory devices; and optionally includes non-volatile memory, such as one or more magnetic disk storage devices, optical disk storage devices, flash memory devices, or other non-volatile solid state storage devices. Memory 370 optionally includes one or more storage devices remotely located from CPU(s) 310. In some embodiments, memory 370 stores programs, modules, and data structures analogous to the programs, modules, and data structures stored in memory 102 of portable multifunction device 100 (Figure 1A), or a subset thereof. Furthermore, memory 370 optionally stores additional programs, modules, and data structures not present in memory 102 of portable multifunction device 100. For example, memory 370 of device 300 optionally stores drawing module 380, presentation module 382, word processing module 384, website creation module 386, disk authoring module 388, and/or spreadsheet module 390, while memory 102 of portable multifunction device 100 (Figure 1A) optionally does not store these modules.

**[00123]** Each of the above identified elements in Figure 3 are, optionally, stored in one or more of the previously mentioned memory devices. Each of the above identified modules corresponds to a set of instructions for performing a function described above. The above identified modules or programs (i.e., sets of instructions) need not be implemented as separate software programs, procedures or modules, and thus various subsets of these modules are, optionally, combined or otherwise re-arranged in various embodiments. In some embodiments, memory 370 optionally stores a subset of the modules and data structures identified above. Furthermore, memory 370 optionally stores additional modules and data structures not described above.

**[00124]** Attention is now directed towards embodiments of user interfaces ("UI") that are, optionally, implemented on portable multifunction device 100.

**[00125]** Figure 4A illustrates an example user interface for a menu of applications on portable multifunction device 100 in accordance with some embodiments. Similar user interfaces are, optionally, implemented on device 300. In some embodiments, user interface 400 includes the following elements, or a subset or superset thereof:

- Signal strength indicator(s) 402 for wireless communication(s), such as cellular and Wi-Fi signals;
- Time 404;
- Bluetooth indicator 405;
- Battery status indicator 406;
- Tray 408 with icons for frequently used applications, such as:
  - Icon 416 for telephone module 138, labeled “Phone,” which optionally includes an indicator 414 of the number of missed calls or voicemail messages;
  - Icon 418 for e-mail client module 140, labeled “Mail,” which optionally includes an indicator 410 of the number of unread e-mails;
  - Icon 420 for browser module 147, labeled “Browser”; and
  - Icon 422 for video and music player module 152, also referred to as iPod (trademark of Apple Inc.) module 152, labeled “iPod”; and
- Icons for other applications, such as:
  - Icon 424 for IM module 141, labeled “Text”;
  - Icon 426 for calendar module 148, labeled “Calendar”;
  - Icon 428 for image management module 144, labeled “Photos”;
  - Icon 430 for camera module 143, labeled “Camera”;
  - Icon 432 for online video module 155, labeled “Online Video”;
  - Icon 434 for stocks widget 149-2, labeled “Stocks”;
  - Icon 436 for map module 154, labeled “Map”;
  - Icon 438 for weather widget 149-1, labeled “Weather”;
  - Icon 440 for alarm clock widget 169-6, labeled “Clock”;
  - Icon 442 for workout support module 142, labeled “Workout Support”;
  - Icon 444 for notes module 153, labeled “Notes”; and

- Icon 446 for a settings application or module, which provides access to settings for device 100 and its various applications 136.

**[00126]** It should be noted that the icon labels illustrated in Figure 4A are merely examples. For example, in some embodiments, icon 422 for video and music player module 152 is labeled “Music” or “Music Player.” Other labels are, optionally, used for various application icons. In some embodiments, a label for a respective application icon includes a name of an application corresponding to the respective application icon. In some embodiments, a label for a particular application icon is distinct from a name of an application corresponding to the particular application icon.

**[00127]** Figure 4B illustrates an example user interface on a device (e.g., device 300, Figure 3) with a touch-sensitive surface 451 (e.g., a tablet or touchpad 355, Figure 3) that is separate from the display 450. Device 300 also, optionally, includes one or more contact intensity sensors (e.g., one or more of sensors 359) for detecting intensity of contacts on touch-sensitive surface 451 and/or one or more tactile output generators 359 for generating tactile outputs for a user of device 300.

**[00128]** Figure 4B illustrates an example user interface on a device (e.g., device 300, Figure 3) with a touch-sensitive surface 451 (e.g., a tablet or touchpad 355, Figure 3) that is separate from the display 450. Many of the examples that follow will be given with reference to a device that detects inputs on a touch-sensitive surface that is separate from the display, as shown in Figure 4B. In some embodiments, the touch-sensitive surface (e.g., 451 in Figure 4B) has a primary axis (e.g., 452 in Figure 4B) that corresponds to a primary axis (e.g., 453 in Figure 4B) on the display (e.g., 450). In accordance with these embodiments, the device detects contacts (e.g., 460 and 462 in Figure 4B) with the touch-sensitive surface 451 at locations that correspond to respective locations on the display (e.g., in Figure 4B, 460 corresponds to 468 and 462 corresponds to 470). In this way, user inputs (e.g., contacts 460 and 462, and movements thereof) detected by the device on the touch-sensitive surface (e.g., 451 in Figure 4B) are used by the device to manipulate the user interface on the display (e.g., 450 in Figure 4B) of the multifunction device when the touch-sensitive surface is separate from the display. It should be understood that similar methods are, optionally, used for other user interfaces described herein.

**[00129]** As used herein, the term “focus selector” refers to an input element that indicates a current part of a user interface with which a user is interacting. In some implementations that include a cursor or other location marker, the cursor acts as a “focus selector,” so that when an input (e.g., a press input) is detected on a touch-sensitive surface (e.g., touchpad 355 in Figure 3 or touch-sensitive surface 451 in Figure 4B) while the cursor is over a particular user interface element (e.g., a button, window, slider or other user interface element), the particular user interface element is adjusted in accordance with the detected input. In some implementations that include a touch-screen display (e.g., touch-sensitive display system 112 in Figure 1A or the touch screen in Figure 4A) that enables direct interaction with user interface elements on the touch-screen display, a detected contact on the touch-screen acts as a “focus selector,” so that when an input (e.g., a press input by the contact) is detected on the touch-screen display at a location of a particular user interface element (e.g., a button, window, slider or other user interface element), the particular user interface element is adjusted in accordance with the detected input. In some implementations, focus is moved from one region of a user interface to another region of the user interface without corresponding movement of a cursor or movement of a contact on a touch-screen display (e.g., by using a tab key or arrow keys to move focus from one button to another button); in these implementations, the focus selector moves in accordance with movement of focus between different regions of the user interface. Without regard to the specific form taken by the focus selector, the focus selector is generally the user interface element (or contact on a touch-screen display) that is controlled by the user so as to communicate the user’s intended interaction with the user interface (e.g., by indicating, to the device, the element of the user interface with which the user is intending to interact). For example, the location of a focus selector (e.g., a cursor, a contact, or a selection box) over a respective button while a press input is detected on the touch-sensitive surface (e.g., a touchpad or touch screen) will indicate that the user is intending to activate the respective button (as opposed to other user interface elements shown on a display of the device).

#### USER INTERFACES AND ASSOCIATED PROCESSES

**[00130]** Attention is now directed towards embodiments of user interfaces (“UI”) and associated processes that may be implemented on an electronic device, such as a portable multifunction device 100 with a display, a touch-sensitive surface, and optionally one or more

sensors to detect intensity of contacts with the touch-sensitive surface, or a device 300 with a one or more processors, non-transitory memory, a display, and an input device.

**[00131]** Figures 5A-5MMM illustrate example user interfaces for pairing edges of windows in accordance with some embodiments. The user interfaces in these figures are used to illustrate the processes described below, including the processes in Figures 8A-8E. Although some of the examples which follow will be given with reference to inputs on a touch-sensitive surface 451 that is separate from the display 450, in some embodiments, the device detects inputs on a touch-screen display (where the touch-sensitive surface and the display are combined), as shown in Figure 4A.

**[00132]** Figures 5A-5T show a window 510 and a window 520 displayed within a display area 501 of the display 450. For example, the window 510 corresponds to a first application, and the window 520 corresponds to a second application different from the first application. For example, the window 510 and the window 520 correspond to a same application. Figures 5A-5MMM show a dock 504 within the display area 501 with a plurality of dock icons 506-A, 506-B, and 506-C corresponding to different applications.

**[00133]** As shown in Figures 5A-5T, the window 510 includes a chrome region 512a and a content region 512b. The window 510 has a right edge 514a, a top edge 514b, and a bottom edge 514c. Similarly, the window 520 includes a chrome region 522a and a content region 522b. The window 520 has a left edge 524a, a top edge 524b, and a bottom edge 524c.

**[00134]** Figures 5A-5B illustrate a sequence in which the right edge 514a of the window 510 is moved toward the left edge 524a of the window 520 and the right edge 514a of the window 510 is paired with the left edge 524a of the window 520 according to a determination that the movement of the window 510 satisfies one or more pairing criteria. In this example, the one or more pairing criteria are satisfied when both an angle criterion and a velocity criterion are satisfied. For example, the angle criterion is satisfied when the angle of the movement deviates from a predefined axis (e.g., an axis normal or perpendicular to the edge being approached) by less than an angular threshold value (e.g., +/- 45° from the predefined axis). As such, according to some embodiments, the angle criterion is satisfied when the angle of approach is between pairing values 516a (e.g., 45°) and 516b (e.g., 315°). For example, the velocity criterion is satisfied when the velocity of the movement is less than a pairing velocity threshold 518.

**[00135]** In Figure 5A, the window 510 is dragged with the focus selector 502 by the chrome region 512a according to the movement vector 508. For example, the right edge 514a of the window 510 is moved toward the left edge 524a of the window 520 according to the movement vector 508. As shown in Figure 5A, the angle of the movement vector 508 (e.g., 15°) relative to a normal associated with the left edge 524a of the window 520 is between the pairing values 516a and 516b. Furthermore, in Figure 5A, the velocity associated with the movement vector 508 is less than the pairing velocity threshold 518.

**[00136]** As such, as shown in Figures 5B-5C, the right edge 514a of the window 510 is paired with the left edge 524a of the window 520. For example, the movement of the window 510 is stopped when the right edge 514a of the window 510 touches the left edge 524a of the window 520 due to satisfaction of the angle criterion and the velocity criterion. However, in Figure 5C, the focus selector 502 moves past the left edge 524a of the window 520 according to the movement vector 508. In some embodiments, when the window is moved (or resized) based on an input from a device with a tactile output generator (e.g., a trackpad with a tactile output generator), a tactile output is generated when the edge of a window (e.g., window 510) is paired with the edge of another window (e.g., window 520). In contrast, in some embodiments, if the edge of the window is moved over the edge of the other window without being paired, then no tactile output is generated to indicate that the edge of the window has passed over the edge of the other window.

**[00137]** Figures 5D-5F illustrate a sequence in which the window 510 is moved substantially parallel to the left edge 524a of the window 520 and the right edge 514a of the window 510 remains paired with the left edge 524a of the window 520 according to a determination that the movement of the window 510 does not satisfy one or more separation criteria. In this example, the one or more separation criteria are satisfied when either an angle criterion or a velocity criterion are satisfied. For example, the angle criterion is satisfied when the angle of the movement deviates from a predefined axis (e.g., an axis normal or perpendicular to the paired edges) by more than an angular threshold value (e.g., +/- 45° from the predefined axis). As such, according to some embodiments, the angle criterion is satisfied when the angle of the movement is not between separation values 530a (e.g., 45°) and 530b (e.g., 135°). For example, the velocity criterion is satisfied when the velocity of the movement is greater than a separation velocity threshold 532.



**[00138]** In Figure 5D, the window 510 is dragged with the focus selector 502 by the chrome region 512a according to the movement vector 526. For example, the right edge 514a of a window 510 is moved substantially parallel to the left edge 524a of the window 520 according to the movement vector 526. As shown in Figure 5D, the angle of the movement vector 526 (e.g.,  $75^\circ$ ) relative to a normal associated with the left edge 524a of the window 520 is between the separation values 530a and 530b. Furthermore, in Figure 5D, the velocity associated with the movement vector 526 is less than the separation velocity threshold 532.

**[00139]** As such, as shown in Figures 5E-5F, the right edge 514a of the window 510 remains paired with the left edge 524a of the window 520. For example, the window 510 slides parallel to the window 520, but the window 510 remains paired to the window 520 because neither the angle criterion nor the velocity criterion associated with the one or more separation criteria are satisfied. As shown in Figures 5E-5F, the parallel movement of the window 510 is constrained by a line 528a associated with the top edge 524b of the window 520. However, in Figure 5F, the focus selector 502 moves past the line 528a according to the movement vector 526. In some embodiments, when the window is moved (or resized) based on an input from a device with a tactile output generator (e.g., a trackpad or touch-sensitive surface with a tactile output generator), a tactile output is generated when the edge of window 510 reaches a constraint associated with another edge of the window with which it is paired (e.g., the top edge 524b of window 520 in Figure 5E) if the separation criteria is not satisfied. In contrast, in some embodiments, if the separation criteria are satisfied, then no tactile output is generated when the edge of the window reaches the constraint associated with the edge of the other window.

**[00140]** Figures 5G-5J illustrate another sequence in which the window 510 is moved substantially parallel to the left edge 524a of the window 520 and the right edge 514a of the window 510 remains paired with the left edge 524a of the window 520 according to a determination that the movement of the window 510 does not satisfy one or more separation criteria. In this example, the one or more separation criteria are satisfied when either an angle criterion or a velocity criterion are satisfied. For example, the angle criterion is satisfied when the angle of the movement deviates from a predefined axis (e.g., an axis normal or perpendicular to the paired edges) by more than an angular threshold value (e.g.,  $\pm 45^\circ$  from the predefined axis). As such, according to some embodiments, the angle criterion is satisfied when the angle of the movement is not between separation values 536a (e.g.,  $225^\circ$ ) and 536b

(e.g.,  $315^\circ$ ). For example, the velocity criterion is satisfied when the velocity of the movement is greater than a separation velocity threshold 532.

**[00141]** In Figure 5G, the window 510 is dragged with the focus selector 502 by the chrome region 512a according to the movement vector 534. For example, the movement vector 534 is a continuation of the movement in Figures 5D-5F (e.g., click and drag according to movement vector 526, then hold and drag according to movement vector 534). For example, the right edge 514a of a window 510 is moved substantially parallel to the left edge 524a of the window 520 according to the movement vector 534. As shown in Figure 5G, the angle of the movement vector 534 (e.g.,  $285^\circ$ ) relative to a normal associated with the left edge 524a of the window 520 is between the separation values 536a and 536b. Furthermore, in Figure 5G, the velocity associated with the movement vector 534 is less than the separation velocity threshold 532.

**[00142]** As such, as shown in Figures 5H-5J, the right edge 514a of the window 510 remains paired with the left edge 524a of the window 520. For example, the window 510 slides parallel to the window 520, but the window 510 remains paired to the window 520 because neither the angle criterion nor the velocity criterion associated with the one or more separation criteria are satisfied. As shown in Figures 5I-5J, the parallel movement of the window 510 is constrained by a line 528b associated with the bottom edge 524c of the window 520.

**[00143]** Figures 5K-5M illustrate a sequence in which the window 510 is moved substantially perpendicular to the left edge 524a of the window 520 and the right edge 514a of the window 510 is unpaired from the left edge 524a of the window 520 according to a determination that the movement of the window 510 satisfies one or more separation criteria. In this example, the one or more separation criteria are satisfied when an angle criterion is satisfied. For example, the angle criterion is satisfied when the angle of the movement deviates from a predefined axis (e.g., an axis normal or perpendicular to the paired edges) by less than an angular threshold value (e.g.,  $\pm 45^\circ$  from the predefined axis). As such, according to some embodiments, the angle criterion is satisfied when the angle of the movement is between separation values 542a (e.g.,  $135^\circ$ ) and 542b (e.g.,  $225^\circ$ ).

**[00144]** In some embodiments, if a first window is moved away from a paired, second window in a substantially perpendicular direction, the first window is unpaired from the

second window when the angle criterion is satisfied (e.g., no distance criterion in Figures 5K-5M). In some embodiments, if a first window is moved toward a paired, second window in a substantially perpendicular direction, the first window is unpaired from the second window when an angle criterion and a distance criterion is satisfied (e.g., Figures 5Q-5T).

**[00145]** In Figure 5K, the window 510 is dragged with the focus selector 502 by the chrome region 512a according to the movement vector 538. For example, the right edge 514a of a window 510 is moved away from the left edge 524a of the window 520 in a substantially perpendicular direction according to the movement vector 538. As shown in Figure 5K, the angle of the movement vector 538 (e.g.,  $180^\circ$ ) relative to a normal associated with the left edge 524a of the window 520 is between the separation values 542a and 542b.

**[00146]** As such, as shown in Figures 5L-5M, the right edge 514a of the window 510 is separated from and no longer paired with the left edge 524a of the window 520. For example, the window 510 separates from the window 520 and moves according to the movement vector 538 because the angle criterion and the distance criterion associated with the one or more separation criteria are satisfied.

**[00147]** Figures 5N-5P illustrate another sequence in which the window 510 is moved substantially perpendicular to the left edge 524a of the window 520 and the right edge 514a of the window 510 is unpaired from the left edge 524a of the window 520 according to a determination that the movement of the window 510 satisfies one or more separation criteria. In this example, the one or more separation criteria are satisfied when an angle criterion and a distance criterion are satisfied. For example, the angle criterion is satisfied when the angle of the movement deviates from a predefined axis (e.g., an axis normal or perpendicular to the paired edges) by less than an angular threshold value (e.g.,  $\pm 45^\circ$  from the predefined axis). As such, according to some embodiments, the angle criterion is satisfied when the angle of the movement is between separation values 542a (e.g.,  $135^\circ$ ) and 542b (e.g.,  $225^\circ$ ). For example, the distance criterion is satisfied when the magnitude of the movement is greater than a separation distance threshold 546.

**[00148]** In Figure 5N, the window 510 is dragged with the focus selector 502 by the chrome region 512a according to the movement vector 544. For example, the right edge 514a of a window 510 is moved away from the left edge 524a of the window 520 in a substantially perpendicular direction according to the movement vector 544. As shown in Figure 5N, the

angle of the movement vector 544 (e.g.,  $160^\circ$ ) relative to a normal associated with the left edge 524a of the window 520 is between the separation values 542a and 542b. Furthermore, in Figure 5N, the magnitude associated with the movement vector 544 is greater than the separation distance threshold 546.

**[00149]** As such, as shown in Figures 5O-5P, the right edge 514a of the window 510 is separated from and no longer paired with the left edge 524a of the window 520. For example, the window 510 separates from the window 520 and moves according to the movement vector 544 because the angle criterion and the distance criterion associated with the one or more separation criteria are satisfied. In some embodiments, when the window is moved (or resized) based on an input from a device with a tactile output generator (e.g., a trackpad or touch-sensitive surface with a tactile output generator), a tactile output is generated when the edge of a window (e.g., window 510) is separated (e.g., unpaired) from the edge of another window (e.g., window 520). In some embodiments, when the window is moved (or resized) based on an input from a device with a tactile output generator (e.g., a trackpad or touch-sensitive surface with a tactile output generator), a tactile output is not generated when the edge of a window (e.g., window 510) is separated (e.g., unpaired) from the edge of another window (e.g., window 520) even when the tactile output was generated when the edge of the window (e.g., window 510) was paired with the edge of the other window (e.g., window 520).

**[00150]** Figures 5Q-5T illustrate yet another sequence in which the window 510 is moved substantially perpendicular to the left edge 524a of the window 520 and the right edge 514a of the window 510 is unpaired from the left edge 524a of the window 520 according to a determination that the movement of the window 510 satisfies one or more separation criteria. In this example, the one or more separation criteria are satisfied when an angle criterion and a distance criterion are satisfied. For example, the angle criterion is satisfied when the angle of the movement deviates from a predefined axis (e.g., an axis normal or perpendicular to the paired edges) by less than an angular threshold value (e.g.,  $\pm 45^\circ$  from the predefined axis). As such, according to some embodiments, the angle criterion is satisfied when the angle of the movement is between separation values 552a (e.g.,  $45^\circ$ ) and 552b (e.g.,  $315^\circ$ ). For example, the distance criterion is satisfied when the magnitude of the movement is greater than a separation distance threshold 550.

**[00151]** In some embodiments, the value associated with the distance criterion scales based on the angle of the substantially perpendicular movement. For example, the separation distance threshold 550 in Figure 5Q associated with movement of the window 510 at a 0° angle is less than separation distance threshold 546 in Figure 5N associated with movement of the window 510 at a 160° angle.

**[00152]** In Figure 5Q, the window 510 is dragged with the focus selector 502 by the chrome region 512a according to the movement vector 548. For example, the right edge 514a of a window 510 is moved toward the left edge 524a of the window 520 in a substantially perpendicular direction according to the movement vector 548. As shown in Figure 5Q, the angle of the movement vector 548 (e.g., 0°) relative to a normal associated with the left edge 524a of the window 520 is between the separation values 552a and 552b. Furthermore, in Figure 5Q, the magnitude associated with the movement vector 548 is greater than the separation distance threshold 550.

**[00153]** As shown in Figure 5R-5S, the focus selector 502 moves according to the movement vector 528 and the right edge 514a of the window 510 remains paired with the left edge 524a of the window 520 until the separation distance threshold 550 is satisfied. When the separation distance threshold 550 is satisfied, the window 510 “jumps” between Figures 5S-5T so as to be displayed under the focus selector 502. As such, as shown in Figure 5T, the right edge 514a of the window 510 is separated from and no longer paired with the left edge 524a of the window 520. For example, the window 510 separates from the window 520 and moves according to the movement vector 548 because the angle criterion and the distance criterion associated with the one or more separation criteria are satisfied.

**[00154]** Figures 5U-5JJ show a window 560 and a window 570 displayed within a display area 501 of the display 450. For example, the window 560 corresponds to a first application, and the window 570 corresponds to a second application different from the first application. For example, the window 560 and the window 570 correspond to a same application. As shown in Figures 5U-5JJ, the window 560 includes a chrome region 562a and a content region 562b. The window 560 has a top edge 564a, a left edge 564b, and a right edge 564c. Similarly, the window 570 includes a chrome region 572a and a content region 572b. The window 520 has a bottom edge 574a, a left edge 574b, and a right edge 574c.

**[00155]** Figures 5U-5W illustrate a sequence in which the top edge 564a of the window 560 is moved toward the bottom edge 574a of the window 570 and the top edge 564a of the window 560 is paired with the bottom edge 574a of the window 570 according to a determination that the movement of the window 560 satisfies one or more pairing criteria. In this example, the one or more pairing criteria are satisfied when both an angle criterion and a velocity criterion are satisfied. For example, the angle criterion is satisfied when the angle of the movement deviates from a predefined axis (e.g., the edge being approached) by less than an angular threshold value (e.g., +/- 45° from the predefined axis). As such, according to some embodiments, the angle criterion is satisfied when the angle of approach of the movement is between pairing values 568a (e.g., 45°) and 568b (e.g., 135°). For example, the velocity criterion is satisfied when the velocity of the movement is less than the pairing velocity threshold 518.

**[00156]** In Figure 5U, the window 560 is dragged with the focus selector 502 by the chrome region 562a according to the movement vector 566. For example, the top edge 564a of the window 560 is moved toward the bottom edge 574a of the window 570 according to the movement vector 566. As shown in Figure 5U, the angle of the movement vector 566 (e.g., 80°) relative to the bottom edge 574a of the window 570 is between the pairing values 568a and 568b. Furthermore, in Figure 5U, the velocity associated with the movement vector 566 is less than the pairing velocity threshold 518.

**[00157]** As such, as shown in Figures 5V-5W, the top edge 564a of the window 560 is paired with the bottom edge 574a of the window 570. For example, the movement of the window 560 is stopped when the top edge 564a of the window 560 touches the bottom edge 574a of the window 570 due to satisfaction of the angle criterion and the velocity criterion. However, in Figure 5W, the focus selector 502 moves past the line 528a according to the movement vector 526.

**[00158]** Figures 5X-5Z illustrate a sequence in which the window 560 is moved substantially parallel to the bottom edge 574a of the window 570 and the top edge 564a of the window 560 remains paired with the bottom edge 574a of the window 570 according to a determination that the movement of the window 560 does not satisfy one or more separation criteria. In this example, the one or more separation criteria are satisfied when either an angle criterion or a velocity criterion are satisfied. For example, the angle criterion is satisfied when

the angle of the movement deviates from a predefined axis (e.g., the paired edges) by more than an angular threshold value (e.g.,  $\pm 45^\circ$  from the predefined axis). As such, according to some embodiments, the angle criterion is satisfied when the angle of the movement is not between separation values 580a (e.g.,  $135^\circ$ ) and 580b (e.g.,  $225^\circ$ ). For example, the velocity criterion is satisfied when the velocity of the movement is greater than the separation velocity threshold 532.

**[00159]** In Figure 5X, the window 560 is dragged with the focus selector 502 by the chrome region 562a according to the movement vector 576. For example, the movement vector 576 is a continuation of the movement in Figures 5U-5W (e.g., click and drag according to movement vector 566, then hold and drag according to movement vector 576). For example, the top edge 564a of the window 560 is moved substantially parallel to the bottom edge 574a of the window 570 according to the movement vector 576. As shown in Figure 5X, the angle of the movement vector 576 (e.g.,  $200^\circ$ ) relative to the bottom edge 574a of the window 570 is between the separation values 580a and 580b. Furthermore, in Figure 5X, the velocity associated with the movement vector 576 is less than the separation velocity threshold 532.

**[00160]** As such, as shown in Figures 5Y-5Z, the top edge 564a of the window 560 remains paired with the bottom edge 574a of the window 570. For example, the window 560 slides parallel to the window 570, but the window 560 remains paired to the window 570 because neither the angle criterion nor the velocity criterion associated with the one or more separation criteria are satisfied. As shown in Figure 5Z, the parallel movement of the window 510 is constrained by a line 578a associated with the left edge 574b of the window 570.

**[00161]** Figures 5AA-5DD illustrate a sequence in which the window 570 is moved substantially parallel to the top edge 564a of the window 560 and the top edge 564a of the window 560 remains paired with the bottom edge 574a of the window 570 according to a determination that the movement of the window 570 does not satisfy one or more separation criteria. In this example, the one or more separation criteria are satisfied when either an angle criterion or a velocity criterion are satisfied. For example, the angle criterion is satisfied when the angle of the movement deviates from a predefined axis (e.g., the paired edges) by more than an angular threshold value (e.g.,  $\pm 45^\circ$  from the predefined axis). As such, according to some embodiments, the angle criterion is satisfied when the angle of the movement is not

between separation values 580a (e.g., 135°) and 580b (e.g., 225°). For example, the velocity criterion is satisfied when the velocity of the movement is greater than the separation velocity threshold 532.

**[00162]** In Figure 5AA, the window 570 is dragged with the focus selector 502 by the chrome region 572a according to the movement vector 582. For example, the bottom edge 574a of the window 570 is moved substantially parallel to the top edge 564a of the window 560 according to the movement vector 582. As shown in Figure 5AA, the angle of the movement vector 582 (e.g., 190°) relative to the top edge 564a of the window 560 is between the separation values 580a and 580b. Furthermore, in Figure 5AA, the velocity associated with the movement vector 582 is less than the separation velocity threshold 532.

**[00163]** As such, as shown in Figures 5BB-5DD, the bottom edge 574a of the window 570 remains paired with the top edge 564a of the window 560. For example, the window 570 slides parallel to the window 560, but the window 570 remains paired to the window 560 because neither the angle criterion nor the velocity criterion associated with the one or more separation criteria are satisfied. As shown in Figure 5DD, the parallel movement of the window 570 is constrained by a line 584b associated with the right edge 564c of the window 560.

**[00164]** Figures 5EE-5FF illustrate another sequence in which the window 570 is moved substantially parallel to the top edge 564a of the window 560 and the top edge 564a of the window 560 remains paired with the bottom edge 574a of the window 570 according to a determination that the movement of the window 570 does not satisfy one or more separation criteria. In this example, the one or more separation criteria are satisfied when either an angle criterion or a velocity criterion are satisfied. For example, the angle criterion is satisfied when the angle of the movement deviates from a predefined axis (e.g., the paired edges) by more than an angular threshold value (e.g., +/- 45° from the predefined axis). As such, according to some embodiments, the angle criterion is satisfied when the angle of the movement is not between separation values 590a (e.g., 45°) and 590b (e.g., 315°). For example, the velocity criterion is satisfied when the velocity of the movement is greater than the separation velocity threshold 532.

**[00165]** In Figure 5EE, the window 570 is dragged with the focus selector 502 by the chrome region 572a according to the movement vector 588. For example, the bottom edge



574a of the window 570 is moved substantially parallel to the top edge 564a of the window 560 according to the movement vector 588. As shown in Figure 5EE, the angle of the movement vector 588 (e.g.,  $355^\circ$ ) relative to the top edge 564a of the window 560 is between the separation values 590a and 590b. Furthermore, in Figure 5EE, the velocity associated with the movement vector 588 is less than the separation velocity threshold 532.

**[00166]** As such, as shown in Figure 5FF, the bottom edge 574a of the window 570 remains paired with the top edge 564a of the window 560. For example, the window 570 slides parallel to the window 560, but the window 570 remains paired to the window 560 because neither the angle criterion nor the velocity criterion associated with the one or more separation criteria are satisfied. As shown in Figure 5FF, the parallel movement of the window 570 is constrained by a line 584a associated with the left edge 564b of the window 560.

**[00167]** Figures 5GG-5JJ illustrate a sequence in which the window 560 is moved substantially perpendicular to the bottom edge 574a of the window 570 and the top edge 564a of the window 560 is unpaired from the bottom edge 574a of the window 570 according to a determination that the movement of the window 560 satisfies one or more separation criteria. In this example, the one or more separation criteria are satisfied when an angle criterion and a distance criterion are satisfied. For example, the angle criterion is satisfied when the angle of the movement deviates from a predefined axis (e.g., the paired edges) by less than an angular threshold value (e.g.,  $\pm 45^\circ$  from the predefined axis). As such, according to some embodiments, the angle criterion is satisfied when the angle of the movement is between separation values 596a (e.g.,  $45^\circ$ ) and 596b (e.g.,  $135^\circ$ ). For example, the distance criterion is satisfied when the magnitude of the movement is greater than a separation distance threshold 594.

**[00168]** In Figure 5GG, the window 560 is dragged with the focus selector 502 by the chrome region 562a according to the movement vector 592. For example, the top edge 564a of the window 560 is moved toward the bottom edge 574a of the window 570 in a substantially perpendicular direction according to the movement vector 592. As shown in Figure 5GG, the angle of the movement vector 592 (e.g.,  $90^\circ$ ) relative to the bottom edge 574a of the window 570 is between the separation values 596a and 596b. Furthermore, in

Figure 5GG, the magnitude associated with the movement vector 592 is greater than the separation distance threshold 594.

**[00169]** As shown in Figure 5HH-5II, the focus selector 502 moves according to the movement vector 592 and the right edge 514a of the window 510 remains paired with the left edge 524a of the window 520 until the separation distance threshold 594 is satisfied. When the separation distance threshold 594 is satisfied, the window 560 “jumps” between Figures 5II-5JJ so as to be displayed under the focus selector 502. As such, as shown in Figure 5JJ, the top edge 564a of the window 560 is unpaired from the bottom edge 574a of the window 570. For example, the window 560 separates from the window 570 and moves according to the movement vector 592 because the angle criterion and the distance criterion associated with the one or more separation criteria are satisfied.

**[00170]** Figures 5KK-5NN show a window 5100 and a window 5110 displayed within a display area 501 of the display 450. For example, the window 5100 corresponds to a first application, and the window 5110 corresponds to a second application different from the first application. For example, the window 5100 and the window 5110 correspond to a same application. As shown in Figures 5KK-5NN, the window 5100 includes a chrome region 5102a and a content region 5102b, and the window 5100 has a right edge 5104a. Similarly, the window 5110 includes a chrome region 5112a and a content region 5112b, and the window 5110 has a left edge 5114a.

**[00171]** Figures 5KK-5MM illustrate a sequence in which the right edge 5104a of the window 5100 is moved toward the left edge 5114a of the window 5110 and the right edge 5104a of the window 5100 is not paired with the left edge 5114a of the window 5110 according to a determination that the movement of the window 5100 does not satisfy one or more pairing criteria. In this example, the one or more pairing criteria are satisfied when both an angle criterion and a velocity criterion are satisfied. For example, the angle criterion is satisfied when the angle of the movement deviates from a predefined axis (e.g., an axis normal or perpendicular to the edge being approached) by less than an angular threshold value (e.g., +/- 45° from the predefined axis). As such, according to some embodiments, the angle criterion is satisfied when the angle of approach of the movement is between pairing values 516a (e.g., 45°) and 516b (e.g., 315°). For example, the velocity criterion is satisfied when the velocity of the movement is less than the pairing velocity threshold 518.

**[00172]** In Figure 5KK, the window 5100 is dragged with the focus selector 502 by the chrome region 5102a according to the movement vector 5106. For example, the right edge 5104a of the window 5100 is moved toward the left edge 5114a of the window 5110 according to the movement vector 5106. As shown in Figure 5KK, the angle of the movement vector 5106 (e.g., 80°) relative to a normal associated with the left edge 5114a of the window 5110 is not between the pairing values 516a and 516b. Furthermore, in Figure 5KK, the velocity associated with the movement vector 5106 is less than the pairing velocity threshold 518.

**[00173]** As such, as shown in Figure 5LL, the right edge 5104a of the window 5100 is not paired with the left edge 5114a of the window 5110. For example, the movement of the window 5100 continues according to the movement vector 5106 and overlaps the window 5110 because the angle criterion is not satisfied.

**[00174]** Figures 5MM-5NN illustrate another sequence in which the right edge 5104a of the window 5100 is moved toward the left edge 5114a of the window 5110 and the right edge 5104a of the window 5100 is not paired with the left edge 5114a of the window 5110 according to a determination that the movement of the window 5100 does not satisfy one or more pairing criteria. In this example, the one or more pairing criteria are satisfied when both an angle criterion and a velocity criterion are satisfied. For example, the angle criterion is satisfied when the angle of the movement deviates from a predefined axis (e.g., an axis normal or perpendicular to the edge being approached) by less than an angular threshold value (e.g., +/- 45° from the predefined axis). As such, according to some embodiments, the angle criterion is satisfied when the angle of approach of the movement is between pairing values 516a (e.g., 45°) and 516b (e.g., 315°). For example, the velocity criterion is satisfied when the velocity of the movement is less than the pairing velocity threshold 518.

**[00175]** In Figure 5MM, the window 5100 is dragged with the focus selector 502 by the chrome region 5102a according to the movement vector 5108. For example, the right edge 5104a of the window 5100 is moved toward the left edge 5114a of the window 5110 according to the movement vector 5108. As shown in Figure 5MM, the angle of the movement vector 5108 (e.g., 35°) relative to a normal associated with the left edge 5114a of the window 5110 is between the pairing values 516a and 516b. Furthermore, in Figure 5MM, the velocity associated with the movement vector 5108 is greater than the pairing velocity threshold 518.

**[00176]** As such, as shown in Figure 5NN, the right edge 5104a of the window 5100 is not paired with the left edge 5114a of the window 5110. For example, the movement of the window 5100 continues according to the movement vector 5108 and overlaps the window 5110 because the velocity criterion is not satisfied.

**[00177]** Figures 5OO-5PP show a window 5120 and a window 5130 displayed within a display area 501 of the display 450. For example, the window 5120 corresponds to a first application, and the window 5130 corresponds to a second application different from the first application. For example, the window 5120 and the window 5130 correspond to a same application. As shown in Figures 5OO-5PP, the window 5120 includes a chrome region 5122a and a content region 5122b, and the window 5120 has a right edge 5124a. Similarly, the window 5130 includes a chrome region 5132a and a content region 5132b, and the window 5130 has a right edge 5134a.

**[00178]** Figures 5OO-5PP illustrate a sequence in which the right edge 5124a of the window 5120 is moved toward the right edge 5134a of the window 5130 and the right edge 5124a of the window 5120 is not paired with the right edge 5134a of the window 5130 because the window 5120 overlaps the window 5130. In this example, the one or more pairing criteria are satisfied when both an angle criterion and a velocity criterion are satisfied. For example, the angle criterion is satisfied when the angle of the movement deviates from a predefined axis (e.g., an axis normal or perpendicular to the edge being approached) by less than an angular threshold value (e.g.,  $\pm 45^\circ$  from the predefined axis). As such, according to some embodiments, the angle criterion is satisfied when the angle of approach of the movement is between pairing values 516a (e.g.,  $45^\circ$ ) and 516b (e.g.,  $315^\circ$ ). For example, the velocity criterion is satisfied when the velocity of the movement is less than the pairing velocity threshold 518.

**[00179]** In Figure 5OO, the window 5120 is dragged with the focus selector 502 by the chrome region 5122a according to the movement vector 5126. For example, the right edge 5124a of the window 5120 is moved toward the right edge 5134a of the window 5130 according to the movement vector 5126. As shown in Figure 5OO, the angle of the movement vector 5126 (e.g.,  $10^\circ$ ) relative to a normal associated with the right edge 5134a of the window 5130 is between the pairing values 516a and 516b. Furthermore, in Figure 5OO, the velocity associated with the movement vector 5126 is less than the pairing velocity threshold 518.

**[00180]** However, as shown in Figure 5PP, the right edge 5124a of the window 5120 is not paired with the right edge 5134a of the window 5130. For example, the movement of the window 5120 continues according to the movement vector 5126 because the window 5120 at least partially overlaps the window 5130 prior to the movement.

**[00181]** Figures 5QQ-5TT show a window 5140 and a window 5150 displayed within a display area 501 of the display 450. For example, the window 5140 corresponds to a first application, and the window 5150 corresponds to a second application different from the first application. For example, the window 5140 and the window 5150 correspond to a same application.

**[00182]** As shown in Figures 5QQ-5TT, the window 5140 includes a chrome region 5142a and a content region 5142b, and the window 5140 has a right edge 5144a. Similarly, the window 5150 includes a chrome region 5152a and a content region 5152b, and the window 5150 has a left edge 5154a. As shown in Figures 5QQ-5RR, the left edge 5154a of the window 5150 is associated with an attraction zone 5156. For example, the attraction zone 5156 extends N pixels from the left edge 5154a of the window 5150. For example, if the window 5140 is moved within the attraction zone 5156 associated with the window 5150 (e.g., the movement stops within the attraction zone 5156), the right edge 5144a of the window 5140 is magnetically attracted to the left edge 5154a of the window 5150. As a result, the right edge 5144a of the window 5140 adjoins (e.g., touches) and does not overlap the left edge 5154a of the window 5150.

**[00183]** Figures 5QQ-5RR illustrate a sequence in which the right edge 5144a of the window 5140 is moved within the attraction zone 5156 associated with the left edge 5154a of the window 5150 and the right edge 5144a of the window 5140 is adjoined with the left edge 5154a of the window 5150. In Figure 5QQ, the window 5140 is dragged with the focus selector 502 by the chrome region 5142a according to the movement vector 5146. For example, the right edge 5144a of a window 5140 is moved toward the left edge 5154a of the window 5150 according to the movement vector 5146. Figure 5RR shows the window 5140 within the attraction zone 5156 after the movement vector 5146 is completed.

**[00184]** As such, as shown in Figure 5SS, the right edge 5144a of the window 5140 is adjoined with the left edge 5154a of the window 5150. For example, the window 5140 is

adjoined with the window 5150 due to the window 5140 being moved within the attraction zone 5156 associated with the window 5150.

**[00185]** Figures 5SS-5TT illustrate a sequence in which the window 5140 is separated from the window 5150. In Figure 5SS, the window 5140 is dragged with the focus selector 502 by the chrome region 5142a according to the movement vector 5156. For example, the right edge 5144a of a window 5140 is moved substantially parallel to the left edge 5154a of the window 5150. As shown in Figure 5TT, the right edge 5144a of the window 5140 is separated from with the left edge 5154a of the window 5150 without satisfying any separation criteria. For example, the movement of the window 5140 continues according to the movement vector 5156 because the window 5140 and the window 5150 were not paired due to the satisfaction of one or more pairing criteria.

**[00186]** In some embodiments, when the windows are adjoined via magnetic attraction, the windows are separated when a distance threshold is satisfied. As such, for example, there is a threshold resistance when the first window is moved towards or away from the second window. In some embodiments, when the windows are adjoined via magnetic attraction, the windows are separated without satisfying a distance threshold is satisfied. As such, for example, there is no resistance when the first window is moved towards or away from the second window.

**[00187]** Figures 5UU-5AAA show a window 5160 and a window 5170 displayed within a display area 501 of the display 450. For example, the window 5160 corresponds to a first application, and the window 5170 corresponds to a second application different from the first application. For example, the window 5160 and the window 5170 correspond to a same application. As shown in Figures 5UU-5AAA, the window 5160 includes a chrome region 5162a and a content region 5162b, and the window 5160 has a right edge 5164a and a top edge 5164b. Similarly, the window 5170 includes a chrome region 5172a and a content region 5172b, and the window 5170 has a left edge 5174a and a top edge 5174b.

**[00188]** Figures 5UU-5WW illustrate a sequence in which the right edge 5164a of the window 5160 is dragged toward the left edge 5174a of the window 5170 and the right edge 5164a of the window 5160 is paired with the left edge 5174a of the window 5170. In this example, the one or more pairing criteria are satisfied when both an angle criterion and a velocity criterion are satisfied. For example, the angle criterion is satisfied when the angle of

the movement deviates from a predefined axis (e.g., an axis normal or perpendicular to the edge being approached) by less than an angular threshold value (e.g., +/- 45° from the predefined axis). As such, according to some embodiments, the angle criterion is satisfied when the angle of approach of the movement is between pairing values 516a (e.g., 45°) and 516b (e.g., 315°). For example, the velocity criterion is satisfied when the velocity of the movement is less than the pairing velocity threshold 518.

**[00189]** In Figure 5UU, the right edge 5164a of the window 5160 is dragged with the focus selector 502 according to the movement vector 5166. For example, the right edge 5164a of the window 5160 is dragged toward the left edge 5174a of the window 5170 according to the movement vector 5166. As shown in Figure 5UU, the angle of the movement vector 5166 (e.g., 15°) relative to a normal associated with the left edge 5174a of the window 5170 is between the pairing values 516a and 516b. Furthermore, in Figure 5UU, the velocity associated with the movement vector 5166 is less than the pairing velocity threshold 518.

**[00190]** As such, as shown in Figure 5VV, the right edge 5164a of the window 5160 is paired with the left edge 5174a of the window 5170. For example, the dragging of the right edge 5164a of the window 5160 is stopped when the right edge 5164a of the window 5160 touches the left edge 5174a of the window 5170 due to satisfaction of the angle criterion and the velocity criterion. A first dimension (e.g., the width) of the window 5160 has a value 5168a in Figure 5UU. The first dimension of the window 5160 has a value 5168b in Figure 5VV after the right edge 5164a of the window 5160 is paired with the left edge 5174a of the window 5170. For example, the value 5168a is less than the value 5168b. However, in Figure 5WW, the focus selector 502 moves past the left edge 5174a of the window 5170 according to the movement vector 5166.

**[00191]** Figures 5XX-5ZZ illustrate a sequence in which the top edge 5164b of the window 5160 is dragged substantially parallel to the left edge 5174a of the window 5170. In Figure 5XX, the top edge 5164b of the window 5160 is dragged with the focus selector 502 according to the movement vector 5176. For example, the top edge 5164b of the window 5160 is dragged substantially parallel to the left edge 5174a of the window 5170 according to the movement vector 5176.

**[00192]** As such, as shown in Figure 5XX-5ZZ, the right edge 5164a of the window 5160 remains paired with the left edge 5174a of the window 5170. A second dimension (e.g.,

the height) of the window 5160 has a value 5177a in Figure 5XX. The second dimension of the window 5160 has a value 5177b in Figures 5YY-5ZZ after the top edge 5164b is dragged substantially parallel to the left edge 5174a of the window 5170. For example, the value 5177a is less than the value 5177b. As shown in Figures 5YY-5ZZ, the parallel movement of the window 510 is constrained by a line 5178a associated with the top edge 5174b of the window 5170.

**[00193]** As shown in Figures 5YY-5AAA, the focus selector 502 moves according to the movement vector 5176 and the right edge 5164a of the window 5160 remains paired with the left edge 5174a of the window 5170 until the focus selector moves a threshold distance past the line 5178a. When the threshold distance is satisfied, the window 5160 “jumps” between Figures 5ZZ-5AAA so as to be displayed under the focus selector 502 (e.g., a discontinuous animation).

**[00194]** Figures 5BBB-5GGG show a window 5180 and a window 5190 displayed within a display area 501 of the display 450. For example, the window 5180 corresponds to a first application, and the window 5190 corresponds to a second application different from the first application. For example, the window 5180 and the window 5190 correspond to a same application. As shown in Figures 5BBB-5GGG, the window 5180 includes a chrome region 5182a and a content region 5182b, and the window 5180 has a right edge 5184a and a top edge 5184b. Similarly, the window 5190 includes a chrome region 5192a and a content region 5192b, and the window 5190 has a left edge 5194a and a top edge 5194b.

**[00195]** Figures 5BBB-5CCC illustrate a sequence in which the right edge 5184a of the window 5180 is moved toward the left edge 5194a of the window 5190 and the right edge 5184a of the window 5180 is paired with the left edge 5194a of the window 5190 because the movement of the window 5180 satisfies the one or more pairing criteria. In this example, the one or more pairing criteria are satisfied when both an angle criterion and a distance criterion are satisfied. For example, the angle criterion is satisfied when the angle of the movement deviates from a predefined axis (e.g., an axis normal or perpendicular to the edge being approached) by less than an angular threshold value (e.g., +/- 45° from the predefined axis). As such, according to some embodiments, the angle criterion is satisfied when the angle of approach of the movement is between pairing values 516a (e.g., 45°) and 516b (e.g., 315°).



**[00196]** For example, the distance criterion is satisfied when a portion of the magnitude of the movement is less than a distance threshold 5188. For example, the distance criterion is satisfied when the magnitude of the movement is equal to or greater than the initial distance between the right edge 5184a of the window 5180 and the left edge 5194a of the window 5190, but the portion of the magnitude of the movement that extends beyond the left edge 5194a of the window 5190 is also less than or equal to the distance threshold 5188.

**[00197]** In Figure 5BBB, the window 5180 is dragged with the focus selector 502 by the chrome region 5182a according to the movement vector 5186. For example, the right edge 5184a of a window 5180 is moved toward the left edge 5194a of the window 5190 according to the movement vector 5186. As shown in Figure 5BBB, the angle of the movement vector 5186 (e.g., 15°) relative to a normal associated with the left edge 5194a of the window 5190 is between the pairing values 516a and 516b. Furthermore, in Figure 5BBB, the portion of the magnitude of the movement vector 5186 that extends beyond the left edge 5194a of the window 5190 is less than the distance threshold 5188.

**[00198]** As such, as shown in Figure 5CCC, the right edge 5184a of the window 5180 is paired with the left edge 5194a of the window 5190. For example, the movement of the window 5180 is stopped when the right edge 5184a of the window 5180 touches the left edge 5194a of the window 5190 due to satisfaction of the angle criterion and the distance criterion.

**[00199]** Figures 5DDD-5EEE illustrate a sequence in which the window 5180 is moved substantially parallel to the left edge 5194a of the window 5190 and the right edge 5184a of the window 5180 is unpaired from the left edge 5194a of the window 5190 according to a determination that the movement of the window 5180 satisfies one or more separation criteria. In this example, the one or more separation criteria are satisfied when either an angle criterion or a distance criterion are satisfied. For example, the angle criterion is satisfied when the angle of the movement deviates from a predefined axis (e.g., an axis normal or perpendicular to the paired edges) by more than an angular threshold value (e.g., +/- 45° from the predefined axis). As such, according to some embodiments, the angle criterion is satisfied when the angle of the movement is not between separation values 530a (e.g., 45°) and 530b (e.g., 135°). For example, the distance criterion is satisfied when a portion of the magnitude of the movement is greater than a distance threshold 5189. For example, the distance criterion is satisfied when the portion magnitude of the movement that extends beyond the line 5198a

associated with the top edge 5194b of the window 5190 is greater than a distance threshold 5189.

**[00200]** In Figure 5DDD, the window 5180 is dragged with the focus selector 502 by the chrome region 5182a according to the movement vector 5196. For example, the right edge 5184a of a window 5180 is moved substantially parallel to the left edge 5194a of the window 5190 according to the movement vector 5196. As shown in Figure 5DDD, the angle of the movement vector 5196 (e.g.,  $75^\circ$ ) relative to a normal associated with the left edge 5194a of the window 5190 is between the separation values 530a and 530b. Furthermore, in Figure 5DDD, the portion of the magnitude of the movement vector 5196 that extends beyond the left edge 5194a of the window 5190 extends beyond the line 5198a associated with the top edge 5194b of the window 5190 is greater than the distance threshold 5189.

**[00201]** As such, as shown in Figure 5EEE, the right edge 5184a of the window 5180 is unpaired from the left edge 5194a of the window 5190. For example, the window 5180 separates from the window 5190 and moves according to the movement vector 5196 because the angle criterion and the distance criterion associated with the one or more separation criteria are satisfied.

**[00202]** Figures 5FFF-5GGG illustrate a sequence in which the right edge 5184a of the window 5180 is moved toward the left edge 5194a of the window 5190 and the right edge 5184a of the window 5180 is not paired with the left edge 5194a of the window 5190 because the movement of the window 5180 does not satisfy the one or more pairing criteria. In this example, the one or more pairing criteria are satisfied when both an angle criterion and a distance criterion are satisfied. For example, the angle criterion is satisfied when the angle of the movement deviates from a predefined axis (e.g., an axis normal or perpendicular to the edge being approached) by less than an angular threshold value (e.g.,  $\pm 45^\circ$  from the predefined axis). As such, according to some embodiments, the angle criterion is satisfied when the angle of approach of the movement is between pairing values 516a (e.g.,  $45^\circ$ ) and 516b (e.g.,  $315^\circ$ ).

**[00203]** For example, the distance criterion is satisfied when a portion of the magnitude of the movement is less than a distance threshold 5188. For example, the distance criterion is satisfied when the magnitude of the movement is equal to or greater than the initial distance between the right edge 5184a of the window 5180 and the left edge 5194a of the window

5190, but the portion of the magnitude of the movement that extends beyond the left edge 5194a of the window 5190 is also less than or equal to the distance threshold 5188.

**[00204]** In Figure 5FFF, the window 5180 is dragged with the focus selector 502 by the chrome region 5182a according to the movement vector 5202. For example, the right edge 5184a of a window 5180 is moved toward the left edge 5194a of the window 5190 according to the movement vector 5186. As shown in Figure 5FFF, the angle of the movement vector 5202 (e.g., 15°) relative to a normal associated with the left edge 5194a of the window 5190 is between the pairing values 516a and 516b. Furthermore, in Figure 5FFF, the portion of the magnitude of the movement vector 5202 that extends beyond the left edge 5194a of the window 5190 is greater than the distance threshold 5188.

**[00205]** As such, as shown in Figure 5GGG, the right edge 5184a of the window 5180 is not paired with the left edge 5194a of the window 5190. For example, the movement of the window 5180 continues according to the movement vector 5202 and overlaps the window 5190 because the distance criterion is not satisfied.

**[00206]** Figures 5HHH-5JJJ show a window 5210, a window 5220, and a window 5230 displayed within a display area 501 of the display 450. For example, the window 5210 corresponds to a first application, the window 5220 corresponds to a second application, and the window 5230 corresponds to a third application. For example, the window 5210, the window 5220, and the window 5230 correspond to a same application. As shown in Figures 5HHH-5JJJ, the window 5210 includes a chrome region 5212a and a content region 5212b, and the window 5210 has a left edge 5214a. Similarly, the window 5220 includes a chrome region 5222a and a content region 5222b, and the window 5220 has a right edge 5224a. Similarly, the window 5230 includes a chrome region 5232a and a content region 5232b, and the window 5230 has a right edge 5234a and a left edge 5234b.

**[00207]** Figures 5HHH-5JJJ illustrate a sequence in which the left edge 5214a of the window 5210 is moved toward the right edge 5234a of the window 5230 and the left edge 5214a of the window 5210 is not paired with the right edge 5234a of the window 5230 because the window 5230 is partially occluded by the window 5220. In this example, the one or more pairing criteria are satisfied when both an angle criterion and a velocity criterion are satisfied. For example, the angle criterion is satisfied when the angle of the movement deviates from a predefined axis (e.g., an axis normal or perpendicular to the edge being approached) by less

than an angular threshold value (e.g.,  $\pm 45^\circ$  from the predefined axis). As such, according to some embodiments, the angle criterion is satisfied when the angle of approach of the movement is between pairing values 5218a (e.g.,  $135^\circ$ ) and 5218b (e.g.,  $225^\circ$ ). For example, the velocity criterion is satisfied when the velocity of the movement is less than the pairing velocity threshold 518.

**[00208]** In Figure 5HHH, the window 5210 is dragged with the focus selector 502 by the chrome region 5212a according to the movement vector 5216. For example, the left edge 5214a of the window 5210 is moved toward the right edge 5234a of the window 5230 according to the movement vector 5216. As shown in Figure 5HHH, the angle of the movement vector 5216 (e.g.,  $185^\circ$ ) relative to a normal associated with the right edge 5234a of the window 5230 is between the pairing values 5218a and 5218b. Furthermore, in Figure 5HHH, the velocity associated with the movement vector 5216 is less than the pairing velocity threshold 518.

**[00209]** However, as shown in Figure 5III, the left edge 5214a of the window 5210 is not paired with the right edge 5234a of the window 5230. For example, in Figure 5JJJ, the movement of the window 5210 continues according to the movement vector 5216 because the right edge 5234a of the window 5230 is partially occluded by the window 5220 (e.g., as shown by the dotted line within the window 5220 in Figures 5HHH-5JJJ). In another example, according to some embodiments, assuming that the movement vector 5216 satisfies the one or more pairing criteria and that window 5220 occludes a portion of the left edge 5234b by the window 5230 and not a portion of the right edge 5234a of the window 5230 (not shown), the left edge 5214a of the window 5210 is paired with the right edge 5234a of the window 5230.

**[00210]** Figures 5KKK-5MMM show a window 5250, a window 5260, and a window 5270 displayed within a display area 501 of the display 450. For example, the window 5250 corresponds to a first application, the window 5260 corresponds to a second application, and the window 5270 corresponds to a third application. For example, the window 5250, the window 5260, and the window 5270 correspond to a same application. As shown in Figures 5KKK-5MMM, the window 5250 includes a chrome region 5252a and a content region 5252b, and the window 5250 has a left edge 5254a. Similarly, the window 5260 includes a chrome region 5262a and a content region 5262b, and the window 5260 has a right edge

5264a. Similarly, the window 5270 includes a chrome region 5272a and a content region 5272b, and the window 5270 has a right edge 5274a and a left edge 5274b.

**[00211]** Figures 5KKK-5MMM illustrate a sequence in which the left edge 5254a of the window 5250 is moved toward the right edge 5264a of the window 5260 and the left edge 5254a of the window 5250 is not paired with the right edge 5264a of the window 5260 because the window 5260 is partially occluded by the window 5270. In this example, the one or more pairing criteria are satisfied when both an angle criterion and a velocity criterion are satisfied. For example, the angle criterion is satisfied when the angle of the movement deviates from a predefined axis (e.g., an axis normal or perpendicular to the edge being approached) by less than an angular threshold value (e.g.,  $\pm 45^\circ$  from the predefined axis). As such, according to some embodiments, the angle criterion is satisfied when the angle of approach of the movement is between pairing values 5218a (e.g.,  $135^\circ$ ) and 5218b (e.g.,  $225^\circ$ ). For example, the velocity criterion is satisfied when the velocity of the movement is less than the pairing velocity threshold 518.

**[00212]** In Figure 5KKK, the window 5250 is dragged with the focus selector 502 by the chrome region 5252a according to the movement vector 5256. For example, the left edge 5254a of the window 5250 is moved toward the right edge 5264a of the window 5260 according to the movement vector 5256. As shown in Figure 5KKK, the angle of the movement vector 5256 (e.g.,  $185^\circ$ ) relative to a normal associated with the right edge 5264a of the window 5260 is between the pairing values 5218a and 5218b. Furthermore, in Figure 5KKK, the velocity associated with the movement vector 5256 is less than the pairing velocity threshold 518.

**[00213]** However, as shown in Figure 5MMM, the left edge 5254a of the window 5250 is not paired with the right edge 5264a of the window 5260. For example, in Figures 5LLL-5MMM, the movement of the window 5250 continues according to the movement vector 5256 because the right edge 5264a of the window 5260 incident the movement vector 5256 is occluded by the window 5270 (e.g., as shown by the dotted line within the window 5270 in Figures 5KKK-5MMM). As such, in this example, the window 5270 occludes the position on the right edge 5264a of the window 5260 at which the movement vector 5256 contacts the right edge 5264a of the window 5260.

**[00214]** Figures 6A-6Y illustrate example user interfaces for resizing windows in accordance with some embodiments. The user interfaces in these figures are used to illustrate the processes described below, including the processes in Figures 9A-9D. Although some of the examples which follow will be given with reference to inputs on a touch-sensitive surface 451 that is separate from the display 450, in some embodiments, the device detects inputs on a touch-screen display (where the touch-sensitive surface and the display are combined), as shown in Figure 4A.

**[00215]** Figures 6A-6G show a window 610 displayed within a display area 601 of the display 450. As shown in Figures 6A-6G, the window 610 includes a chrome region 612a and a content region 612b. The window 610 has a left edge 614a, a top edge 614b, a right edge 614c, and a bottom edge 614d. For example, the window 610 corresponds to a first application. Figures 6A-6Y show a dock 604 within the display area 601 with a plurality of dock icons 607-A, 607-B, and 607-C corresponding to different applications. In Figures 6A-6Y, the display area 601 includes a top edge 606a, a left edge 606b, a bottom edge 606c, and a right edge 606d.

**[00216]** Figures 6A-6B illustrate a sequence in which two edges of the window 610 move to corresponding edges of the display area 601 (e.g., so as to expand two dimensions of the window) in response to a second input type (e.g., a stationary input such as a double click) with the focus selector 602 on a corner of the window 610. Figure 6A illustrates the focus selector 602 over the corner of the window 610 that is associated with the intersection of the left edge 614a and the top edge 614b of the window 610. In some embodiments, the focus selector 602 is displayed as a double headed arrow when positioned over an edge of a window to indicate that the user is interacting with the edge of the window. In some embodiments, the focus selector 602 is displayed as a cursor when positioned inside the chrome region of a window, inside the content region of a window, or outside of a window within the display area 601.

**[00217]** As shown in Figure 6B, the left edge 614a of the window 610 moves to the left edge 606b of the display area 601, and the top edge 614b of the window 610 moves to the top edge 606a of the display area 601 in response to the double click with the focus selector 602 on the corner of the window 610 in Figure 6A. As shown in Figure 6B, the right edge 614c of the window 610 does not move to the right edge 606d of the display area 601,

and the bottom edge 614d of the window 610 does not move to the bottom edge 606c of the display area 601. As shown in Figures 6A-6B, the position of the focus selector 602 does not change due to the stationary input in Figure 6A.

**[00218]** In some embodiments, an outline of the expanded dimensions of the window 610 are shown within the display area 601 (e.g., as shown by the dotted lines in Figure 6A). The first dimension (e.g., the width) of the window 610 has a value 616a in Figure 6A and a value 616b in Figure 6B. For example, the value 616b is greater than the value 616a. Similarly, the second dimension (e.g., the height) of the window 610 has a value 618a in Figure 6A and a value 618b in Figure 6B. For example, the value 618b is greater than the value 618a.

**[00219]** Figures 6C-6D illustrate a sequence in which the two edges of the window 610 move to their former positions in response to a second input type (e.g., a stationary input such as a double click) with the focus selector 602 on a corner of the window 610. Figure 6C illustrates the focus selector 602 over the corner of the window 610 that is associated with the intersection of the left edge 614a and the top edge 614b. As shown in Figure 6D, the left edge 614a of the window 610 and the top edge of the window 610 move to their former positions in Figure 6A in response to the double click with the focus selector 602 on the corner of the window 610 in Figure 6C. As shown in Figures 6C-6D, the position of the focus selector 602 does not change due to the stationary input in Figure 6C. The first dimension (e.g., the width) of the window 610 has the value 616b in Figure 6C and the value 616a in Figure 6D. For example, the value 616b is greater than the value 616a. Similarly, the second dimension (e.g., the height) of the window 610 has the value 618b in Figure 6C and the value 618a in Figure 6D. For example, the value 618b is greater than the value 618a.

**[00220]** Figures 6E-6G illustrate a sequence in which two dimensions of the window 610 are resized in response to a first input type (e.g., a selection followed by movement such as a click and drag gesture) with the focus selector 602 on a corner of the window 610. Figure 6E illustrates dragging the corner of the window 610 that is associated with the intersection of the right edge 614c and the top edge 614b with the focus selector 602 according to a movement vector 615. As shown in Figures 6F-6G, the first dimension (e.g., the width) of the window 610 expands and the second dimension (e.g., the height) of the window 610 expands

according to the movement vector 615 in Figure 6E that drags the corner of the window 610 that is associated with the intersection of the right edge 614c and the top edge 614b.

**[00221]** The first dimension (e.g., the width) of the window 610 has the value 616a in Figure 6E, the value 616c in Figure 6F, and the value 616d in Figure 6G. For example, the value 616d is greater than the value 616c, which is greater than the value 616a. Similarly, the second dimension (e.g., the height) of the window 610 has the value 618a in Figure 6E, the value 618c in Figure 6F, and the value 618d in Figure 6G. For example, the value 618d is greater than the value 618c, which is greater than the value 618a.

**[00222]** Figures 6H-6K show a window 620 and a window 630 displayed within a display area 601 of the display 450. For example, the window 620 corresponds to a first application, and the window 630 corresponds to a second application different from the first application. For example, the window 620 and the window 630 correspond to a same application. As shown in Figures 6H-6K, the window 620 includes a chrome region 622a and a content region 622b, and the window 620 has a right edge 624a and a left edge 624b. Similarly, the window 630 includes a chrome region 632a and a content region 632b, and the window 630 has a right edge 634a.

**[00223]** Figures 6H-6J illustrate a sequence in which a respective dimension (e.g., the width) of the window 620 is resized in a first direction (e.g., left-to-right) in response to a user input with the focus selector 602 on an edge of the window 610 that corresponds to the first input type (e.g., a selection followed by movement such as a click and drag gesture). Figure 6H illustrates dragging the right edge 624a of the window 620 toward the right edge 606d of the display area 601 with the focus selector 602 according to a movement vector 625. As shown in Figures 6H-6J, the first dimension (e.g., the width) of the window 620 is extended to the right edge 606d of the display area 601 in the first direction (e.g., left-to-right) according to the user input that drags the right edge 624a of the window 620 to the right edge 606d of the display area 601. The first dimension (e.g., the width) of the window 620 has the value 626a in Figure 6H, the value 626b in Figure 6I, and the value 626c in Figure 6J. For example, the value 626c is greater than the value 626b, which is greater than the value 626a.

**[00224]** Figures 6J-6K illustrate a sequence in which the respective dimension (e.g., the width) of the window 620 is resized in a second direction (e.g., right-to-left) when the user input with the focus selector 602 that corresponds to the first input type (e.g., a selection



followed by movement such as a click and drag gesture) satisfies one or more expansion criteria. Figure 6J illustrates maintaining the focus selector 602 at the right edge 606d of the display area 601. For example, the user input holds the right edge 624a of the window 620 at the right edge of the display area 601 after dragging the right edge 624a of the window 620 to the right edge 606d of the display area 601 in Figure 6J. In some embodiments, the one or more expansion criteria are satisfied when the click and drag input holds an edge of a window at an edge of the display area for a predefined time duration. In some embodiments, the one or more expansion criteria are satisfied when the magnitude of the click and drag input moves an edge of a window a predefined distance over an edge of the display area. In some embodiments, when the window is moved (or resized) based on an input from a device with a tactile output generator (e.g., a trackpad with a tactile output generator), a tactile output is generated when the window (e.g., window 620) is expanded (e.g., based on the satisfaction of expansion criteria such as when the click and drag input holds an edge of a window at an edge of the display area for a predefined time duration) to a boundary in the user interface (e.g., an edge of another window or an edge of the display area). In contrast, in some embodiments, if the window is not expanded (e.g., because the input moving or resizing the window does not meet the expansion criteria), then no tactile output is generated to indicate that the window has been expanded to the boundary in the user interface.

**[00225]** As shown in Figure 6K, the first dimension (e.g., the width) of the window 620 is extended to the right edge 634a of the window 630 in the second direction (e.g., right-to-left) when the user input satisfies the one or more expansion criteria in Figure 6G. For example, the left edge 624b of the window 620 expands to the right edge 634a of the window 630. For example, assuming that the window 630 was not located between the left edge 624b of the window 620 and the left edge 606b of the display area 601, the left edge 624b of the window 620 would move to the left edge 606b of the display area 601. Thus, in Figure 6K, the extension of first dimension of the window 620 in the second direction is constrained by the intervening window 630. The first dimension (e.g., the width) of the window 620 has the value 626c in Figure 6J and the value 626d in Figure 6K. For example, the value 626d is greater than the value 626c.

**[00226]** Figures 6L-6O show a window 640 displayed within a display area 601 of the display 450. As shown in Figures 6L-6O, the window 640 includes a chrome region 642a and a content region 642b. The window 640 has a right edge 644a, a top edge 644b, a left edge

644c, and a bottom edge 644d. For example, the window 640 corresponds to a first application.

**[00227]** Figures 6L-6M illustrate a sequence in which a first edge of the window 640 moves to a corresponding first edge of the display area 601 in response to the second input type (e.g., a stationary input such as a double click) with the focus selector 602 on the first edge of the window 640. Figure 6L illustrates the focus selector 602 over the right edge 644a of the window 640.

**[00228]** As shown in Figure 6M, the right edge 644a of the window 640 moves to the right edge 606d of the display area 601 in response to the double click with the focus selector 602 on the right edge 644a of the window 640 in Figure 6L. As shown in Figure 6M, the top edge 644b of the window 640 does not move to the top edge 606a of the display area 601, the left edge 644c of the window 610 does not move to the left edge 606b of the display area 601, the bottom edge 644d of the window 610 does not move to the bottom edge 606c of the display area 601. As shown in Figures 6L-6M, the position of the focus selector 602 does not change due to the stationary input in Figure 6L.

**[00229]** In some embodiments, an outline of the expanded dimensions of the window 640 are shown within the display area 601 (e.g., as shown in Figure 6L). The first dimension (e.g., the width) of the window 610 has a value 646a in Figure 6L and a value 646b in Figure 6M. For example, the value 646b is greater than the value 646a.

**[00230]** Figures 6N-6O illustrate a sequence in which a second edge of the window 640 moves to corresponding second edge of the display area 601 in response to the second input type (e.g., a stationary input such as a double click) with the focus selector 602 on the second edge of the window 640. Figure 6N illustrates the focus selector 602 over the top edge 644b of the window 640.

**[00231]** As shown in Figure 6O, the top edge 644b of the window 640 moves to the top edge 606a of the display area 601 in response to the double click with the focus selector 602 on the top edge 644b of the window 640 in Figure 6N. As shown in Figure 6O, the left edge 644c of the window 610 does not move to the left edge 606b of the display area 601, and the bottom edge 644d of the window 610 does not move to the bottom edge 606c of the display area 601. As shown in Figures 6N-6O, the position of the focus selector 602 does not change due to the stationary input in Figure 6N.

**[00232]** In some embodiments, an outline of the expanded dimensions of the window 640 are shown within the display area 601 (e.g., as shown in Figure 6N). The second dimension (e.g., the height) of the window 640 has a value 648a in Figure 6N and a value 648b in Figure 6O. For example, the value 648b is greater than the value 648a.

**[00233]** Figures 6P-6S show a window 650 and a window 660 displayed within a display area 601 of the display 450. For example, the window 650 corresponds to a first application, and the window 660 corresponds to a second application different from the first application. For example, the window 650 and the window 660 correspond to a same application. As shown in Figures 6P-6S, the window 650 includes a chrome region 652a and a content region 652b, and the window 650 has a right edge 654a, a bottom edge 654b, a left edge 654c, and a top edge 654d. Similarly, the window 660 includes a chrome region 662a and a content region 662b, and the window 660 has a right edge 664a.

**[00234]** Figures 6P-6Q illustrate a sequence in which an edge of the window 650 moves to an intervening edge of the window 660, which is between the edge of the window 650 and a corresponding edge of the display area 601, in response to the second input type (e.g., a stationary input such as a double click) with the focus selector 602 on the edge of the window 650. Figure 6P illustrates the focus selector 602 over the right edge 654a of the window 650.

**[00235]** As shown in Figure 6Q, the right edge 654a of the window 650 moves to the right edge 664a of the window 660 in response to the double click with the focus selector 602 on the right edge 654a of the window 650 in Figure 6P. As shown in Figure 6Q, the bottom edge 654b of the window 650 does not move to the bottom edge 606c of the display area 601, the left edge 654c of the window 650 does not move to the left edge 606b of the display area 601, and the top edge 654d of the window 650 does not move to the top edge 606a of the display area 601. As shown in Figures 6P-6Q, the position of the focus selector 602 does not change due to the stationary input in Figure 6P. In some embodiments, an outline of the expanded dimensions of the window 650 are shown within the display area 601 (e.g., as shown in Figure 6P).

**[00236]** For example, assuming that the window 660 was not located between the right edge 654a of the window 650 and the right edge 606d of the display area 601, the right edge 654a of the window 650 would move to the right edge 606d of the display area 601. Thus, in

Figure 6Q, the movement of the right edge 654a of the window 650 is constrained by the intervening window 660. The first dimension (e.g., the width) of the window 650 has a value 656a in Figure 6P and a value 656b in Figure 6Q. For example, the value 656b is greater than the value 656a.

**[00237]** Figures 6R-6S illustrate a sequence in which the edge of the window 650 moves to its former position in response to the second input type (e.g., a stationary input such as a double click) with the focus selector 602 on the edge of the window 650. Figure 6R illustrates the focus selector 602 over the right edge 654a of the window 650. As shown in Figure 6S, the right edge 654a of the window 650 moves to its former position in Figure 6P in response to the double click with the focus selector 602 on the right edge 654a of the window 650 in Figure 6R. As shown in Figures 6R-6S, the position of the focus selector 602 does not change due to the stationary input in Figure 6R. The first dimension (e.g., the width) of the window 650 has the value 656b in Figure 6R and the value 656a in Figure 6S. For example, the value 656b is greater than the value 656a.

**[00238]** Figures 6T-6U show a window 670, a window 680, and a window 690 displayed within a display area 601 of the display 450. For example, the window 670 corresponds to a first application, the window 680 corresponds to a second application, and the window 690 corresponds to a third application. For example, the window 670, the window 680, and the window 690 correspond to a same application. As shown in Figures 6T-6U, the window 670 includes a chrome region 672a and a content region 672b, and the window 670 has a top edge 674a, a right edge 674b, a bottom edge 674c, and a left edge 674d. Similarly, the window 680 includes a chrome region 682a and a content region 682b, and the window 680 has a top edge 684a. Similarly, the window 690 includes a chrome region 692a and a content region 692b, and the window 690 has a bottom edge 694a. As shown in Figure 6R, the window 670 at least partially overlaps the window 680.

**[00239]** Figures 6T-6U illustrate a sequence in which an edge of the window 670 moves to an intervening edge of the window 690, which is between the edge of the window 670 and a corresponding edge of the display area 601, in response to the second input type (e.g., a stationary input such as a double click) with the focus selector 602 on the edge of the window 670. Figure 6T illustrates the focus selector 602 over the top edge 674a of the window 670.

**[00240]** As shown in Figure 6U, the top edge 674a of the window 670 moves to the bottom edge 694a of the window 690 in response to the double click with the focus selector 602 on the top edge 674a of the window 670 in Figure 6T. As shown in Figure 6U, the right edge 674b of the window 670 does not move to the right edge of 606d of the display area 601, the bottom edge 674c of the window 670 does not move to the bottom edge 606c of the display area 601, and the left edge 674d of the window 670 does not move to the left edge 606b of the display area 601. As shown in Figures 6T-6U, the position of the focus selector 602 does not change due to the stationary input in Figure 6T. In some embodiments, an outline of the expanded dimensions of the window 670 are shown within the display area 601 (e.g., as shown in Figure 6T).

**[00241]** For example, assuming that the window 690 was not located between the top edge 674a of the window 670 and the top edge 606a of the display area 601, the top edge 674a of the window 670 would move to the top edge 606a of the display area 601. Thus, in Figure 6U, the movement of the top edge 674a of the window 670 is constrained by the intervening window 690.

**[00242]** Moreover, the top edge 674a of the window 670 is not constrained by the top edge 684a of the window 680 because the window 670 at least partially overlaps the window 680 prior to the double click with the focus selector 602 on the top edge 674a of the window 670 in Figure 6T. As such, the movement of the top edge 674a of the window 670 is constrained by the intervening window 690 but not by the overlapped (background) window 680. Similarly, in some embodiments, the movement of edges of windows to edges of the display area are not constrained by occluded edges of windows. The first dimension (e.g., the width) of the window 670 has a value 676a in Figure 6T and a value 676b in Figure 6U. For example, the value 676b is greater than the value 676a.

**[00243]** Figures 6V-6Y show a window 6100 and a window 6110 displayed within a display area 601 of the display 450. For example, the window 6100 corresponds to a first application, and the window 6110 corresponds to a second application different from the first application. For example, the window 6100 and the window 6110 correspond to a same application. As shown in Figures 6V-6Y, the window 6100 includes a chrome region 6102a and a content region 6102b, and the window 6100 has a right edge 6104a, a bottom edge

6104b, a left edge 6104c, and a top edge 6104d. Similarly, the window 6110 includes a chrome region 6112a and a content region 6112b, and the window 6110 has a left edge 6114a.

**[00244]** Figures 6V-6Y illustrate a sequence in which two edges of the window 6100 move to corresponding edges of the display area 601 in response to a second input type (e.g., a stationary input such as a double click) with the focus selector 602 on a corner of the window 6100. Figure 6V illustrates the focus selector 602 over the corner of the window 6100 that is associated with the intersection of the right edge 6104a and the bottom edge 6104b of the window 6100.

**[00245]** As shown in Figure 6W, the right edge 6104a of the window 6100 moves to the left edge 6114a of the window 6110, and the bottom edge 6104b of the window 6100 moves to the bottom edge 606c of the display area 601 in response to the double click with the focus selector 602 on the corner of the window 6100 in Figure 6V. As shown in Figure 6W, the left edge 6104c of the window 6100 does not move to the left edge 606b of the display area 601, and the top edge 6104d of the window 6100 does not move to the top edge 606a of the display area 601. As shown in Figures 6V-6W, the position of the focus selector 602 does not change due to the stationary input in Figure 6W. In some embodiments, an outline of the expanded dimensions of the window 6100 are shown within the display area 601 (e.g., as shown in Figure 6V).

**[00246]** In some embodiments, the expansion of dimensions of windows to edges of the display area are not constrained by the dock 604. In some embodiments, the expansion of dimensions of windows to edges of the display area are constrained by the dock 604.

**[00247]** For example, assuming that the window 6110 was not located between the right edge 6104a of the window 6100 and the right edge 606d of the display area 601, the right edge 6104a of the window 6100 would move to the right edge 606d of the display area 601. Thus, in Figure 6W, the movement of the right edge 6104a of the window 6100 is constrained by the intervening window 6110. The first dimension (e.g., the width) of the window 6100 has a value 6106a in Figure 6V and a value 6106b in Figure 6W. For example, the value 6106b is greater than the value 6106a. Similarly, the second dimension (e.g., the height) of the window 6100 has a value 6108a in Figure 6V and a value 6108b in Figure 6W. For example, the value 6108b is greater than the value 6108a.

**[00248]** Figures 6X-6Y illustrate a sequence in which an edge of the window 6100 moves to its former position in response to the second input type (e.g., a stationary input such as a double click) with the focus selector 602 over the edge of the window 6100. As shown in Figure 6Y, the right edge 6104a of the window 6100 moves to its former position in Figure 6V in response to the double click with the focus selector 602 on the right edge 6104a of the window 6100. Furthermore, as shown in Figure 6Y, the bottom edge 6104b of the window 6100 maintains its position in response to the double click with the focus selector 602 on the right edge 6104a of the window 6100. As shown in Figures 6X-6Y, the position of the focus selector 602 does not change due to the stationary input in Figure 6X. The first dimension (e.g., the width) of the window 6100 has the value 6106b in Figure 6X and the value 6106a in Figure 6Y. For example, the value 6106b is greater than the value 6106a.

**[00249]** Figures 7A-7R illustrate example user interfaces for providing tabbed window functionality in accordance with some embodiments. The user interfaces in these figures are used to illustrate the processes described below, including the processes in Figures 10A-10C. Although some of the examples which follow will be given with reference to inputs on a touch-sensitive surface 451 that is separate from the display 450, in some embodiments, the device detects inputs on a touch-screen display (where the touch-sensitive surface and the display are combined), as shown in Figure 4A.

**[00250]** Figures 7A-7B show windows 710, 720, and 730 associated with application A displayed within a display area 701 of the display 450. Figures 7A-7M show a dock 704 within the display area 701 with a plurality of dock icons 706-A, 706-B, and 706-C corresponding to different applications. For example, the dock icon 706-A corresponds to application A (e.g., a web browser application), the dock icon 706-B corresponds to application B (e.g., a word processing application), and the dock icon 706-B corresponds to application C (e.g., an image viewing and editing application).

**[00251]** As shown in Figures 7A-7B, the window 710 includes a chrome region 712a and a content region 712b. Similarly, the window 720 includes a chrome region 722a and a content region 722b. And, the window 730 includes a chrome region 732a and a content region 732b. In Figure 7A, the window 730 is displayed in the foreground as indicated by the shading of the chrome region 732a.

**[00252]** As shown in Figures 7A-7G, a menu bar 709 for application A is also displayed within the display area 701. In Figures 7A-7G, the menu bar 709 includes a plurality of affordances associated with commands, functions, and/or operations of application A. For example, the menu bar 709 for application A includes: a file affordance 708a, which, when activated (e.g., with the focus selector 702), causes a drop-down menu of file options associated with application A to be overlaid on the display area 701; an edit affordance 708b, which, when activated (e.g., with the focus selector 702), causes a drop-down menu of edit options associated with application A to be overlaid on the display area 701; a view affordance 708c, which, when activated (e.g., with the focus selector 702), causes a drop-down menu of view options associated with application A to be overlaid on the display area 701; a history affordance 708d, which, when activated (e.g., with the focus selector 702), causes a list of previously viewed/visited electronic documents (e.g., documents, images, web pages, etc.) associated with application A to be overlaid on the display area 701; a bookmarks affordance 708e, which, when activated (e.g., with the focus selector 702), causes a list of favorited/bookmarked electronic documents (e.g., documents, images, web pages, etc.) associated with application A to be overlaid on the display area 701; a window affordance 708f, which, when activated (e.g., with the focus selector 702), causes a drop-down menu of window options associated with application A to be overlaid on the display area 701; and a help affordance 708g, which, when activated (e.g., with the focus selector 702), causes a drop-down menu of help options associated with application A to be overlaid on the display area 701.

**[00253]** In Figures 7A-7B, application A is running in the foreground as indicated by the shading of the dock icon 706-A, and the text description 707 in the menu bar 709. In Figures 7A-7B, application A is operating in windowed mode (e.g., non-full screen mode), and the operating system is operating in manual tab mode (e.g., the “Manual” behavior described in greater detail with reference to Figures 7E-7G). As such, in some embodiments, when a new window command is issued to application A (e.g., a new window menu option is selected, a predefined new window gesture is performed, a predefined new window combination of keystrokes is performed such as “Ctrl+N”, a predefined new window verbal command is performed, or the like), a new window is displayed in the display area 701.

**[00254]** Figures 7A-7B illustrate a sequence in which a new window is added to the user interface in response to a new window command issued to an application while the



application is in windowed mode. Figure 7B illustrates displaying window 740 associated with application A within the display area 701 in response to a new window command issued to application A (e.g., by way of a “Ctrl+N” operation). As shown in Figure 7B, the window 740 includes a chrome region 742a and a content region 742b. In Figure 7A, the window 740 is displayed in the foreground as indicated by the shading of the chrome region 742a.

**[00255]** Figures 7B-7D illustrate a sequence in which a plurality of windows associated with a respective application are merged into a single window with tabs for each of the plurality of windows. Figure 7B also illustrates the focus selector 702 at a location corresponding to the window affordance 708f. Figure 7C illustrates a drop-down menu 746 of window options overlaid on the display area 701 in response to selection of the window affordance 708f (e.g., with a single or double click of the focus selector 702) in Figure 7B.

**[00256]** As shown in Figure 7C, the drop-down menu 746 of window options includes: a new window affordance 748a, which, when activated (e.g., with the focus selector 702), causes a new window associated with application A to be displayed; a new tab affordance 748b, which, when activated (e.g., with the focus selector 702), causes a new tab associated with application A to be displayed; a “create tabbed window” affordance 748c, which, when activated (e.g., with the focus selector 702), causes open windows to be merged into a single tabbed window; a maximize all windows affordance 748d, which, when activated (e.g., with the focus selector 702), causes open windows associated with application A to be displayed in full screen mode; a cascade windows affordance 748e, which, when activated (e.g., with the focus selector 702), causes open windows associated with application A to be cascaded within the display area 701; and a show all windows affordance 748e, which, when activated (e.g., with the focus selector 702), causes open windows associated with application A to be displayed in exposé mode.

**[00257]** Figure 7C also illustrates the focus selector 702 at a location corresponding to the “create tabbed window” affordance 748c. Figure 7D illustrates displaying a merged window 750 within the display area 701 in response to selection of the “create tabbed window” affordance 748c (e.g., with a single or double click of the focus selector 702) in Figure 7C.

**[00258]** As shown in Figure 7D, the merged window 750 includes a chrome region 752a, a content region 752b, and a tab bar 752c. In Figure 7D, the tab bar 752c includes a tab

756a associated with the window 710, a tab 756b associated with the window 720, a tab 756c associated with the window 730, and a tab 756d associated with the window 740 (e.g., from Figure 7B). In Figure 7D, the tab 756d associated with the window 740 is displayed in the foreground within the merged window 750 as indicated by the shading of the tab 756d. In Figure 7D, the tab bar 752c also includes an addition affordance 758 provided to add a new tab associated with application A to the merged window 750. For example, the new tab is added as a foreground or background tab.

**[00259]** In some embodiments, the “create tabbed window” affordance 748c enables windows associated with applications that do not have native tab functionality to be displayed in a tabbed window. As such, for example, open windows are resized to a same size and stacked on top of one another such that the foreground window is displayed on the top of the stack. In this example, the tabs are displayed within a virtual tab bar superimposed on the top window of the stack of windows by the operating system. In some embodiments, if another tab is selected within the tab bar, a window associated with selected tab is moved to the top of the stack of windows.

**[00260]** In some embodiments, if a close tab command is issued to a tab, the operating system issues a command to the application to close a window that corresponds to the tab. In some embodiments, if a close/exit command is issued to the merged window, the operating system issues a command to the application to close each of the windows that correspond to the tabs in the merged window. According to some embodiments, tabs may be dragged out of the tab bar to move a window out of the stack of windows and to view the window separate from the stack of windows. According to some embodiments, windows may be dragged into the merged window and consequently added to the merged window as a new tab (e.g., either as a foreground or background tab). Thus, in some embodiments, tabbing functionality is enabled by the operating system for applications without native tab functionality.

**[00261]** Figures 7E-7G illustrate a sequence in which a tab setting associated with an operating system (OS) is changed. Figure 7E illustrates a dock menu 760 overlaid on the windows 710, 720, and 730 (e.g., from Figure 7A). For example, the dock menu 760 includes a plurality of options associated with the operating system. For example, the dock menu 760 is accessed through a control panel or system preferences interface. As shown in Figure 7E, the dock menu 760 includes: a slider 762a for adjusting the size of the dock 704; a

magnification slider 762d for adjusting the magnification of size of the dock 704, a picker menu 762c for changing the animation used to minimize windows (e.g., a scaling or genie effect); and a picker menu 762d for changing the tabs preference (e.g., “Manual” mode in which open new windows as windows, “Always” mode in which open new windows as tabs, or “Full Screen Only” mode in which open new windows as tabs only while in full screen mode). In Figure 7E, the current setting associated with the picker menu 762c is the “Genie Effect,” and the current setting associated with the picker menu 762d is the “Manual” behavior. As such, for example, the “Manual” behavior was in effect in in Figures 7A-7D.

**[00262]** In some embodiments, the tabs preference associated with the picker menu 762d applies to applications without native tabbing functionality. In some embodiments, the tabs preference associated with the picker menu 762d applies to all applications. In some embodiments, the tabs preference associated with the picker menu 762d applies to all application save applications included on an opt-out list.

**[00263]** Figure 7E also illustrates the focus selector 702 at a location corresponding to current setting for the picker menu 762d. Figure 7F illustrates a plurality of options for the picker menu 762d overlaid on the display area 701. As shown in Figure 7F, the picker menu 762d includes a “Manual” option 764a, where a new window operation issued to an application opens a window and a new tab operation issued to the application opens a new tab when the application has native tabbing functionality. The picker menu 762d also includes an “Always” option 764b, where a new window operation issued to an application opens a new tab and (optionally) a new tab operation issued to the application opens a new window. The picker menu 762d further includes a “Full Screen Only” option 764c, where a new window operation issued to an application while in full screen mode opens a new tab and (optionally) a new tab operation issued to the application while in full screen mode opens a new window.

**[00264]** Figure 7F also illustrates the focus selector 702 at a location corresponding to the “Always” option 764b. Figure 7G shows “Always” as the current setting associated with the picker menu 762d in response to selection of the “Always” option 764b (e.g., with a single or double click of the focus selector 702) in Figure 7F. As such, for example, the “Always” behavior is in effect in Figures 7H-7M.

**[00265]** Figure 7H shows a window 760 associated with application B and a window 770 associated with application A displayed within a display area 701 of the display 450. As shown in Figure 7H, the window 760 includes a chrome region 762a and a content region 762b. Similarly, the window 770 includes a chrome region 772a and a content region 772b. In Figure 7H, the window 760 is displayed in the foreground as indicated by the shading of the chrome region 762a. In Figure 7H, application B is running in the foreground as indicated by the shading of the dock icon 706-B, and the text description 707 in the menu bar 709.

**[00266]** As shown in Figures 7H-7J, a menu bar 709 for application B is also displayed within the display area 701. In Figures 7H-7J, the menu bar 709 includes a plurality of affordances associated with commands, functions, and/or operations of application B. For example, the menu bar 709 for application B includes: a file affordance 778a, which, when activated (e.g., with the focus selector 702), causes a drop-down menu of file options associated with application B to be overlaid on the display area 701; an edit affordance 778b, which, when activated (e.g., with the focus selector 702), causes a drop-down menu of edit options associated with application B to be overlaid on the display area 701; a view affordance 778c, which, when activated (e.g., with the focus selector 702), causes a drop-down menu of view options associated with application B to be overlaid on the display area 701; an insert affordance 778d, which, when activated (e.g., with the focus selector 702), causes a drop-down menu of edit options associated with application B to be overlaid on the display area 701; a format affordance 778e, which, when activated (e.g., with the focus selector 702), causes a drop-down menu of formatting options associated with application B to be overlaid on the display area 701; a window affordance 778f, which, when activated (e.g., with the focus selector 702), causes a drop-down menu of window options associated with application B to be overlaid on the display area 701; and a help affordance 778g, which, when activated (e.g., with the focus selector 702), causes a drop-down menu of help options associated with application B to be overlaid on the display area 701.

**[00267]** In Figures 7H-7M, application B is operating in windowed mode (e.g., non-full screen mode), and the operating system is operating in automatic tab mode (e.g., the “Manual” behavior described in greater detail with reference to Figures 7E-7G). As such, in some embodiments, when a new window command is issued to application B (e.g., a new window menu option is selected, a predefined new window gesture is performed, a predefined new window combination of keystrokes is performed such as “Ctrl+N”, a predefined new

window verbal command is performed, or the like), a merged window is displayed with a background tab associated with the previous foreground window (e.g., the window 760) and a new foreground tab associated with the new foreground window.

**[00268]** Figures 7H-7I illustrate a sequence in which a new window for a second application is added as a foreground tab within a merged window. Figure 7I illustrates displaying merged window 765 within the display area 701 in response to a new window command issued to application B (e.g., by way of a “Ctrl+N” operation). As shown in Figure 7I, the merged window 765 includes a chrome region 767a, a content region 767b, and a tab bar 767c. In Figure 7I, the merged window 765 is displayed in the foreground as indicated by the shading of the chrome region 767a.

**[00269]** As shown in Figure 7I, the tab bar 767c includes a tab 764a that corresponds to the window 760 (e.g., from Figure 7H) and a tab 764b that corresponds to the new window associated with application B. In Figure 7I, the tab 764b associated with the new window is displayed in the foreground within the merged window 765 as indicated by the shading of the tab 764b. In Figure 7I, the tab bar 767c also includes an addition affordance 766 for adding a new tab associated with application B to the merged window 765. For example, the new tab is added as a foreground or background tab.

**[00270]** In some embodiments, the merged window 765 enables windows associated with applications that do not have native tab functionality to be displayed in a tabbed window. As such, for example, the windows that correspond to the tabs 764a and 764b are resized to a same size and stacked on top of one another such that the foreground window is displayed on the top of the stack of windows (e.g., the new window associated with the tab 764b in Figure 7I). According to some embodiments, the tabs are displayed within a virtual tab bar superimposed on the new foreground window by the operating system. Thus, in some embodiments, tabbing functionality is enabled by the operating system for applications without native tab functionality.

**[00271]** Figures 7I-7J illustrate a sequence in which the foreground tab within the merged window is changed. Figure 7I also illustrates the focus selector 702 at a location corresponding to the tab 764a. Figure 7J shows that the tab 764a associated the window 760 (e.g., from Figure 7H) is displayed in the foreground within the merged window 765 as indicated by the shading of the tab 764a in response to selection of the tab 764a (e.g., with a

single or double click of the focus selector 702) in Figure 7I. As such, according to some embodiments, the window 760 (e.g., from Figure 7H) is moved to the top of the stack of windows associated with the tabs 764a and 764b, and the virtual tab bar 767c is redisplayed on top of the window 760.

**[00272]** Figures 7J-7K illustrate a sequence in which a window for a first application is added as a foreground tab in the merged window. Figure 7J also illustrates dragging the window 770 associated with application A by the chrome region 772a to the tab bar 767c of the merged window 765 with the focus selector 702. Figure 7K shows a tab 764c that corresponds to the window 770 (e.g., from Figure 7J) in response to dragging the window 770 into the tab bar 767c in Figure 7J. In Figure 7K, the tab 764c corresponds to the window 770 (e.g., from Figure 7J) is displayed in the foreground within the merged window 765 as indicated by the shading of the tab 764c. Furthermore, in Figure 7K, application A is running in the foreground as indicated by the shading of the dock icon 706-A, and the text description 707 in the menu bar 709.

**[00273]** As such, according to some embodiments, the window 770 (e.g., from Figure 7J) is added to the top of the stack of windows associated with the tabs 764a, 764b, and 764c, and the virtual tab bar 767c is redisplayed on top of the window 770. Thus, the merged window 765 includes tabs the 764a and 764b that correspond to windows associated with application B and the tab 764c corresponding to a window associated with application A.

**[00274]** Figures 7K-7L illustrate a sequence in which a tab is rearranged within the tab bar of the merged window. Figure 7K also illustrates dragging the tab 764c from a first location to the second location within the tab bar 767c with the focus selector 702. Figure 7L shows the tab 764c between tabs 764b and 764b (e.g., a different location as compared to Figure 7K) in response to dragging the tab 764c within the tab bar 767c in Figure 7K.

**[00275]** Figures 7L-7M illustrate a sequence in which a tab is dragged out of the tab bar of the merged window. Figure 7L illustrates dragging the tab 764b out of the tab bar 767c of the merged window 765 with the focus selector 702. Figure 7M illustrates displaying a window 780 associated with application B within the display area 701 in response to dragging the tab 764b out of the tab bar 767c in Figure 7L. For example, the window 780 corresponds to the tab 764b in Figure 7L.

**[00276]** As shown in Figure 7M, the window 780 includes a chrome region 782a and a content region 782b. In Figure 7M, the window 780 is displayed in the foreground as indicated by the shading of the chrome region 782a. In Figure 7M, application B is running in the foreground as indicated by the shading of the dock icon 706-B, and the text description 707 in the menu bar 709.

**[00277]** Figures 7N-7O show window 790 associated with application C displayed within a display area 701 of the display 450. As shown in Figures 7N-7O, the window 790 includes a chrome region 792a and a content region 792b. In Figure 7N, the window 790 is displayed in the foreground as indicated by the shading of the chrome region 792a.

**[00278]** As shown in Figures 7N-7O, a menu bar 709 for application C is also displayed within the display area 701. In Figures 7N-7O, the menu bar 709 includes a plurality of affordances associated with commands, functions, and/or operations of application C. For example, the menu bar 709 for application C includes: a file affordance 798a, which, when activated (e.g., with the focus selector 702), causes a drop-down menu of file options associated with application C to be overlaid on the display area 701; an edit affordance 798b, which, when activated (e.g., with the focus selector 702), causes a drop-down menu of edit options associated with application C to be overlaid on the display area 701; a view affordance 798c, which, when activated (e.g., with the focus selector 702), causes a drop-down menu of view options associated with application C to be overlaid on the display area 701; an go affordance 798d, which, when activated (e.g., with the focus selector 702), causes a drop-down menu of navigation options associated with application C to be overlaid on the display area 701; a tools affordance 798e, which, when activated (e.g., with the focus selector 702), causes a drop-down menu of tools associated with application C to be overlaid on the display area 701; a window affordance 798f, which, when activated (e.g., with the focus selector 702), causes a drop-down menu of window options associated with application C to be overlaid on the display area 701; and a help affordance 798g, which, when activated (e.g., with the focus selector 702), causes a drop-down menu of help options associated with application C to be overlaid on the display area 701.

**[00279]** In Figures 7N-7O, application C is running in the foreground as indicated by the text description 707 in the menu bar 709. In Figures 7N-7O, application C is operating in full screen mode, and the operating system is operating in full screen tab mode (e.g., the “Full

Screen Only” behavior described in greater detail with reference to Figures 7E-7G). As such, in some embodiments, when a new window command is issued to application C (e.g., a new window menu option is selected, a predefined new window gesture is performed, a predefined new window combination of keystrokes is performed such as “Ctrl+N”, a predefined new window verbal command is performed, or the like), a merged window in full screen mode is displayed with a background tab associated with the previous foreground window (e.g., the window 790) and a new foreground tab associated with the new foreground window.

**[00280]** Figures 7N-7O illustrate a sequence in which a new tab is added to a window in response to a new window command issued to an application while the application is in full screen mode. Figure 7O illustrates displaying merged window 795 within the display area 701 in response to a new window command issued to application C (e.g., by way of a “Ctrl+N” operation). As shown in Figure 7O, the merged window 795 includes a chrome region 797a, a content region 797b, and a tab bar 797c. In Figure 7O, the merged window 795 is displayed in the foreground as indicated by the shading of the chrome region 797a.

**[00281]** As shown in Figure 7O, the tab bar 797c includes a tab 794a that corresponds to the window 790 (e.g., from Figure 7N) and a tab 794b that corresponds to the new window associated with application C. In Figure 7O, the tab 794b associated with the new window is displayed in the foreground within the merged window 795 as indicated by the shading of the tab 794b. In Figure 7N, the tab bar 797c also includes an addition affordance 796 for adding a new tab associated with application C to the merged window 795. For example, the new tab is added as a foreground or background tab.

**[00282]** In some embodiments, the merged window 795 enables windows associated with applications that do not have native tab functionality to be displayed in a tabbed window. As such, for example, the windows that correspond to the tabs 794a and 794b are full screen windows stacked on top of one another such that the foreground window is displayed on the top of the stack (e.g., the new window associated with the tab 794b in Figure 7O). According to some embodiments, the tabs are displayed within a virtual tab bar superimposed on the new foreground window by the operating system. Thus, in some embodiments, tabbing functionality is enabled by the operating system for applications without native tab functionality.



**[00283]** Figures 7P-7R are similar to and adapted from Figure 7A. As such, Figure 7A and Figures 7P-7R include similar user interfaces and elements labeled with the same reference number in both figures have the same function, with only the differences are described herein for the sake of brevity. In Figures 7P-7R, application A is running in the foreground as indicated by the shading of the dock icon 706-A, and the text description 707 in the menu bar 709. Figures 7P-7R shows a window 7100 associated with application A displayed within a display area 701 of the display 450. As shown in Figures 7P-7R, the window 7100 includes a chrome region 7102a, a content region 7102b, and a tab bar 7102c. In Figure 7P, the window 7100 is displayed in the foreground as indicated by the shading of the chrome region 7102a.

**[00284]** In Figure 7P, the tab bar 7102c includes a tab 7106a and a tab 7106b. In Figure 7P, the tab 7106b is displayed in the foreground within the window 7100 as indicated by the shading of the tab 7106b. In Figure 7P, the tab bar 7102c also includes an addition affordance 7108 provided to add a new tab associated with application A to the window 7100. For example, the new tab is added as a foreground or background tab.

**[00285]** In Figures 7P-7R, the window 7100 has native tab functionality (e.g., the application A is opted out of the global tab setting). As shown in Figures 7P-7R, application A is operating in windowed mode (e.g., non-full screen mode). As such, in some embodiments, when a new window command is issued to application A (e.g., a new window menu option is selected, a predefined new window gesture is performed, a predefined new window combination of keystrokes is performed such as “Ctrl+N”, a predefined new window verbal command is performed, or the like), a new window associated with the application A is displayed within the display area 701 (e.g., as shown in Figure 7R). As such, in some embodiments, when a new tab command is issued to application A (e.g., a new tab menu option is selected, a predefined new tab gesture is performed, a predefined new tab combination of keystrokes is performed such as “Ctrl+T”, a predefined new tab verbal command is performed, or the like), a new foreground tab associated with the application A is displayed within the window 7100 (e.g., as shown in Figure 7Q).

**[00286]** Figures 7P-7Q illustrate a sequence in which a new tab is added the tabbed window in response to a new tab command issued to application A while operating in windowed mode. Figure 7Q illustrates displaying a new tab 7106c within the tab bar 7102c

in response to a new window command issued to application A (e.g., by way of a “Ctrl+N” operation).

**[00287]** Figure 7P and Figure 7R illustrate a sequence in which a new window is added the tabbed window in response to a new tab command issued to application A while operating in windowed mode. Figure 7R illustrates displaying a new window 7110 in response to a new window command issued to application A (e.g., by way of a “Ctrl+T” operation). As shown in Figure 7R, the window 7110 includes a chrome region 7112a and a content region 7112b.

**[00288]** Figures 8A-8E illustrate a flow diagram of a method 800 of pairing edges of windows in accordance with some embodiments. The method 800 is performed at an electronic device (e.g., the portable multifunction device 100 in Figure 1A, or the device 300 in Figure 3) with a one or more processors, non-transitory memory, a display, and an input device. In some embodiments, the display is a touch-screen display and the input device is on or integrated with the display. In some embodiments, the display is separate from the input device. Some operations in method 800 are, optionally, combined and/or the order of some operations is, optionally, changed.

**[00289]** As described below, the method 800 provides an intuitive way to pair edges of windows. The method reduces the cognitive burden on a user when pairing edges of windows, thereby creating a more efficient human-machine interface. For battery-operated electronic devices, enabling a user to pair edges of windows faster and more efficiently conserves power and increases the time between battery charges.

**[00290]** The device displays (802), on the display, a first window and a second window within a display area, the first window having a first edge parallel to a second edge of the second window. In some embodiments, the first and second windows are rectangular. In some embodiments, the first and second windows are arranged horizontally within the display area with a non-zero distance between the first and second window. For example, the first edge is the right edge of the first window, and the second edge if the left edge of the second window. In another example, the first edge is the left edge of the first window, and the second edge if the right edge of the second window. In some embodiments, the first and second windows are arranged vertically within the display area with a non-zero distance between the first and second windows. For example, the first edge is the bottom edge of the first window, and the second edge if the top edge of the second window. In another example, the first edge is the

top edge of the first window, and the second edge if the bottom edge of the second window. Figure 5A, for example, shows a first window 510 and a second window 520 displayed within the display area 501, where the right edge 514a of the first window 510 (e.g., the first edge) is parallel to the left edge 524a of the second window 520 (e.g., the second edge).

**[00291]** The device detects (804) a first user input, via the input device, moving the first edge of the first window toward the second edge of the second window. In some embodiments, the first user input is associated with a movement vector incident to the second edge. For example, assuming that the first and second windows are arranged horizontally, a right edge of the first window is moved toward a left edge of the second window. In another example, assuming the first and second windows are arranged vertically, a top edge of the first window is moved toward a bottom edge of a second window.

**[00292]** In some embodiments, the first user input corresponds to (806) moving the first window within the display area by dragging the first window toward the second window. In some embodiments, the first user input includes selection of the chrome region of the first window with a focus selector and movement of the first window (e.g., a click and drag the window), where the first edge leads the movement associated with the first user input. As one example, Figures 5A-5C show a sequence in which the window 510 is moved towards the window 520. As another example, Figures 5U-5W show a sequence in which the window 560 is moved toward the window 570.

**[00293]** In some embodiments, the first user input corresponds to (808) resizing the first window within the display area by dragging the first edge of the first window toward the second window. In some embodiments, the first user input includes selection of the edge of the first window with a focus selector and movement of the first edge (e.g., click and drag the first edge), where the first edge leads the movement associated with the first user input. As one example, Figures 5UU-5WW show a sequence in which the right edge 5164a of the window 5160 is dragged toward the left edge 5174a of the window 5170.

**[00294]** In response to detecting the first user input, and in accordance with a determination that the first user input does not satisfy the one or more pairing criteria, the device continues (810) the movement of the first window based on the first user input so that the first window at least partially overlaps the second window. As one example, Figures 5KK-5LL illustrate a sequence in which the window 5100 is moved toward the left edge 5114a of

the window 5110. In this example, the right edge 5104a of the window 5100 does not pair with the left edge 5114a of the window 5110 and the window 5100 moves over the window 5110 because a first pairing criterion (e.g., the angle criterion) is not satisfied. As another example, Figures 5MM-5NN illustrate a sequence in which the window 5100 is moved toward the left edge 5114a of the window 5110. In this example, the right edge 5104a of the window 5100 does not pair with the left edge 5114a of the window 5110 and the window 5100 moves over the window 5110 because a second pairing criterion (e.g., the velocity criterion) is not satisfied. As yet another example, Figures 5FF-5GG illustrate a sequence in which the window 5180 is moved toward the left edge 5194a of the window 5190. In this example, the right edge 5184a of the window 5180 does not pair with the left edge 5194a of the window 5190 and the window 5180 moves over the window 5190 because a third pairing criterion (e.g., the distance criterion) is not satisfied. As such, according to some embodiments, windows are moved and aligned according to conventional behavior when the one or more pairing criteria are not satisfied according to user expectations.

**[00295]** In response to detecting the first user input, and in accordance with a determination that the first user input satisfies one or more pairing criteria (e.g., one or more conditions for pairing the first and second windows), the device pairs (812) the first edge of the first window to the second edge of the second window such that the first window stops moving in response to the first user input before it overlaps the second window, where the one or more pairing criteria include a first pairing criterion that is met when the first input corresponds to movement of the first edge toward the second edge that deviates from a predefined axis by less than an angular threshold value.

**[00296]** According to some embodiments, the first window is paired with the second window by stopping the movement of first edge of the first window so that the first edge of the first window is touching (and not overlapping) the second edge of the second window. As such, pairing the windows includes stopping the movement of the first window once the first and second edges are adjoining. For example, no pixels associated with the first window overlap the second window. For example, there are 0 pixels between the first and second windows. In some embodiments, there is no magnetic attraction between the first and second windows. Instead, the movement at least reaches the second edge of the second window but not more than a threshold value past the second edge. For example, the user deliberately moves the first window to be side-by-side or stacked with the second window. Continuing

with this example, if the one or more pairing criteria are satisfied, the first and second windows are paired. As such, according to some embodiments, the user is able to more easily manage the alignment and arrangement of windows within the display area saving the user time and effort.

**[00297]** In some embodiments, the predefined axis is perpendicular to or normal to the first edge and the second edge. For example, in some embodiments, the angle criterion is satisfied when the angle of approach deviates less than  $45^\circ$  or  $60^\circ$  relative to a normal of the second edge of the second window. As such, the first and second edges are paired when the first user input is substantially parallel to the second edge, and the first and second edges overlap when the first user input is substantially perpendicular to the second edge.

**[00298]** In some embodiments, a second pairing criterion of the one or more pairing criteria includes (814) a velocity threshold value, and satisfying the second pairing criterion includes determining that that a velocity associated with the first user input breaches the velocity threshold value. As one example, Figures 5A-5C show a sequence in which the right edge 514a of the window 510 is paired with the left edge 524a of the window 520 due to satisfaction of the angle criterion (e.g., the angle of the movement vector 508 deviates less than the values 516a and 516b from a normal of the left edge 524a of the window 520) and the velocity criterion (e.g., the velocity of the movement vector 508 is less than the pairing threshold velocity 518). As another example, Figures 5U-5W show a sequence in which the top edge 564a of the window 560 is paired with the bottom edge 574a of the window 570 due to satisfaction of the angle criterion (e.g., the angle of the movement vector 566 deviates less than the values 568a and 568b from a normal of the bottom edge 574a of the window 570) and the velocity criterion (e.g., the velocity of the movement vector 566 is less than the pairing threshold velocity 518).

**[00299]** In some embodiments, a third pairing criterion of the one or more pairing criteria includes (816) a distance threshold value, and satisfying the third pairing criterion includes determining that the input corresponds to movement of the first edge of the window in a respective direction to the edge of the second window without corresponding to more than a threshold amount of movement in the respective direction. In some embodiments, the third pairing criterion when a magnitude of the first user input is greater than or equal to an initial distance value between the first edge of the first window and the second edge of the

second window prior to the first user input, and when the magnitude of the first user input is less than or equal a sum of the initial distance and the distance threshold value. As such, the magnitude of the first user input at least touches the first and second edges but is not greater than a threshold distance beyond the second edge. As one example, Figures 5BBB-5CCC show a sequence in which the right edge 5184a of the window 5180 is paired with the left edge 5194a of the window 5190 due to satisfaction of the angle criterion (e.g., the angle of the movement vector 5186 deviates less than the values 516a and 516b from a normal of the left edge 5194a of the window 5190) and the distance criterion (e.g., the magnitude of a component of the movement vector 5186 that is over the left edge 5194a of the window 5190 is less than the distance threshold 5188).

**[00300]** In some embodiments, the device (820): while the first edge of the first window is paired with the second edge of the second window, detecting a second user input, via the input device, moves the first window away from the second window; and, in response to the second user input, unpairs the first edge of the first window from the second edge of the second window and moves the first window according to a movement vector associated with the second user input. According to some embodiments, if the second user input moves the second window substantially perpendicular to and away from the first edge of the first window, the second window similarly separates from the first window. In some embodiments, the second user input is associated with a movement vector having a component perpendicular to the second edge that satisfies an angular separation threshold criterion. For example, the angular separation criterion is satisfied when the angle of the second user input deviates from a normal of the second edge by less than a threshold angle value. In some embodiments, the windows are immediately unpaired when the second user input is perpendicular to and away from the paired edges (e.g., a 180° angle relative to a normal of the second edge). As such, the windows are unpaired without a distance separation criterion or without any resistance if the angular separation criterion is satisfied. In some embodiments, the windows are unpaired when the second user input is perpendicular to and away from the paired edges and satisfies a distance separation criterion. As such, according to some embodiments, the user is able to unpair windows without resistance. This, for example, enables the user is able to more easily manage the alignment and arrangement of windows within the display area saving the user time and effort.

**[00301]** For example, Figures 5K-5M show a sequence in which the window 510 is moved away from the window 520 at a 180° angle relative to a normal of the left edge 524a of the window 520. In this example, the right edge 514a of the window 510 is unpaired from the left edge 524a of the window 520 without satisfying a distance criterion.

**[00302]** In some embodiments, the device (822): while the first edge of the first window is paired with the second edge of the second window, detects a second component of the first user input moving the first window away from the second window; and, in response to the second component of the first user input and in accordance with a determination that a magnitude of the second component breaches a distance threshold (e.g., at least equal to the magnitude of the first component), unpairs the first edge of the first window from the second edge of the second window and moves the first window according to a movement vector associated with the second component of the first user input. For example, a first component of the first user input moves the first edge towards the second wedge, and a second component of the first user input moves the first edge away from the second edge. In some embodiments, for continuous movement, the first window is unpaired from the second window when the first window is moved by at least the distance the first window was moved to pair the first and second windows (e.g., the distance threshold). As such, according to some embodiments, the user is able to unpair windows with some resistance. This, for example, enables the user is able to more easily manage the alignment and arrangement of windows within the display area saving the user time and effort.

**[00303]** In some embodiments, while the first edge of the first window is paired with the second edge of the second window, the device detects (824) a second user input, via the input device, moving the first window toward the second edge of the second window. In response to detecting the second user input, and in accordance with a determination that the second user input satisfies one or more separation criteria (e.g., one or more conditions for separating the first and second paired windows), the device unpairs the first edge of the first window from the second edge of the second window and moves the first window over the second window according to a movement vector associated with the second user input. In response to detecting the second user input, and in accordance with a determination that the second user input does not satisfy the one or more separation criteria, the device maintains the pairing between the first edge of the first window and the second edge of the second window and foregoes moving the first window over the second window. According to some

embodiments, if the second user input moves the second window substantially perpendicular to and toward the first edge of the first window, the second window similarly separates from the first window or remains paired with the first window. In some embodiments, when the movement is substantially perpendicular to and toward from the paired edges, the windows are unpaired when the second user input satisfies the angular separation criterion (e.g., the angle of the movement towards the second edge deviates less than  $\pm 45^\circ$  from a normal of the second edge) and a distance criterion (e.g., the magnitude of the movement is greater than or equal to a separation distance threshold). As such, according to some embodiments, the user is able to unpair windows with some resistance by reducing the accidental unpairing of windows from each other. This, for example, enables the user is able to more easily manage the alignment and arrangement of windows within the display area saving the user time and effort.

**[00304]** For example, Figures 5Q-5T show a sequence in which the window 510 is moved toward the window 520. In this example, the right edge 514a of the window 510 unpaired from the left edge 524a of the window 520 due to satisfaction of the angular separation criterion (e.g., the angle of the movement vector 548 deviates from the normal of the second edge by less than the values 552a and 552b) and the distance criterion (e.g., the magnitude of the movement vector 548 is greater than the separation distance threshold 550).

**[00305]** In some embodiments, if the second user input is perpendicular to and away from the second edge of the second window, the paired windows are separated when the magnitude of the second user input exceeds a first predefined value. In some embodiments, if the second user input is perpendicular to and toward from the second edge of the second window, the paired windows are separated when the magnitude of the second user input exceeds a second predefined value. In some embodiments, if the second user input is substantially parallel to the first edge of the first window, the paired windows are separated when the magnitude of the second user input exceeds the second predefined value and an angle of the second user input exceeds a predefined value relative to a normal of the second edge of the second window. In some embodiments, the second predefined value is greater than the first predefined value.

**[00306]** In some embodiments, moving the first window over the second window according to the movement vector associated with the second user input includes (826): in



accordance with a determination that the second user input corresponds to moving a focus selector over the second window, displaying an animation such that moving the first window over the second window is discontinuous (e.g., “jump” the first window such that the chrome region appears under the focus selector when the unpairing occurs); and in accordance with a determination that the second user input does not correspond to moving the focus selector over the second window, foregoing displaying the animation such that moving the first window over the second window is continuous. In some embodiments, the first window jumps, if the focus selector moves out from over window while window is paired with another window (e.g., when a bottom window in a stack of paired windows is dragged toward the top window). However, the first window does not “jump”, if the focus selector does not move out from over the window (e.g., when a left window in a side-by-side pair of windows is dragged toward the right window). As such, according to some embodiments, the first window “catches up” to the focus selector so as to provide a smooth user experience. As one example, Figures 5Q-5T show a sequence in which the right edge 514a of the window 510 unpaired from the left edge 524a of the window 520. In Figures 5S, the focus selector moves into the content region 522b of the window 520 according to the movement vector 548. However, as shown in Figures 5S-5T, the window 510 discontinuously “jumps” under the location of the focus selector 502 when the distance separation criterion is satisfied.

**[00307]** In some embodiments, while the first edge of the first window is paired with the second edge of the second window, the device detects (828) a second user input, via the input device, which corresponds to movement of the first edge relative to the second edge. In response to detecting the second user input, and in accordance with a determination that the second user input corresponds to movement of the first window such that the first edge of the first window moves over the second edge, the device delays movement of the first window until the second user input has reached a movement threshold. In response to detecting the second user input, and in accordance with a determination that the second user input corresponds to movement of the first window such that the first edge of the first window moves away from the second edge, the device starts to move the first window before the second user input has reached the movement threshold. As one example, Figures 5Q-5T show a sequence in which the right edge 514a of the window 510 is unpaired from the left edge 524a of the window 520 when the movement vector 548 distance separation criterion is satisfied (e.g., delay movement). As another example, Figures 5K-5M show a sequence in

which the right edge 514a of the window 510 is immediately unpaired from the left edge 524a of the window 520 (e.g., do not delay movement).

**[00308]** In some embodiments, while the first edge of the first window is paired with the second edge of the second window, the device detects (830) a second user input, via the input device, moving the first window along the second edge of the second window. In response to detecting the second user input, and in accordance with a determination that the second user input satisfies one or more separation criteria, the device unpairs the first edge of the first window from the second edge of the second window and moves the first window according to a movement vector associated with the second user input. In response to detecting the second user input, and in accordance with a determination that the second user input does not satisfy any of the one or more separation criteria, the device maintains the pairing between the first edge of the first window and the second edge of the second window and moves the first window parallel to the second edge of the second window according to the second user input. In one example, assuming that the first and second windows are paired side-by-side, if first window is moved away from or toward the second window, the first window is separated from the second window. In another example, assuming that the first and second windows are paired side-by-side, if the first window is moved substantially parallel to the second window toward the top or bottom of the second window, the first window slides parallel to the second window and remains paired with the second window. As such, according to some embodiments, the user is able to more easily manage the alignment and arrangement of windows within the display area saving the user time and effort.

**[00309]** In some embodiments, the separation criteria are the converse of the pairing criteria. In some embodiments, the separation criteria are similar to and adapted from the pairing criteria. For example, the separation criteria are satisfied when the second user exceeds a predefined escape velocity, the angle of the second user input relative to a parallel of the second edge of the second window is greater than a predefined value, and/or the magnitude of the second user input is greater than a predefined value.

**[00310]** As one example, Figures 5N-5P show a sequence in which the right edge 514a of the window 510 is unpaired from the left edge 524a of the window 520 due to satisfaction of the angular separation criterion (e.g., the angle of the movement vector 544 deviates less than +/- 45° from a normal of the second edge) and the distance separation criterion (e.g., the

magnitude of the movement vector 544 is greater than the separation distance threshold 546). As another example, Figures 5D-5F show a sequence in which the right edge 514a of the window 510 remains paired with the left edge 524a of the window 520 because the angular separation criterion (e.g., the angle of the movement vector 526 deviates more than +/- 45° from a normal of the second edge) and the velocity separation criterion (e.g., the velocity of the movement vector 526 is less than the separation velocity threshold 532) are not satisfied.

**[00311]** In some embodiments, the parallel movement of the first window is constrained (832) by a third edge of the second window, and the third edge of the second window is perpendicular to the second edge of the second window. For example, the first window stops moving when an edge of the first window that is parallel to the third edge of the second window is aligned with the third edge of the second window. In some embodiments, the parallel sliding movement is not constrained by the third edge of the second window. For example, in Figures 5E-5F, the parallel movement of the window 510 is constrained by the line 528a associated with the top edge 524b of the window 520. In some embodiments, the parallel movement is not constrained by the third edge of the second window. As such, according to some embodiments, the user is able to more easily manage the alignment and arrangement of windows within the display area saving the user time and effort (e.g., windows with equal height or width).

**[00312]** In some embodiments, while the first edge of the first window is paired with the second edge of the second window, the device detects (834) a second user input, via the input device, moving the second window along the first edge of the first window. In response to detecting the second user input, and in accordance with a determination that the second user input satisfies one or more separation criteria, the device unpairs the second edge of the second window from the first edge of the first window and moves the second window according to second user input. In response to detecting the second user input, and in accordance with a determination that the second user input does not satisfy any of the one or more of the separation criteria, the device maintains the pairing between the first edge of the first window and the second edge of the second window and moves the second window parallel to the first edge of the first window according to a movement vector associated with the second user input. As such, according to some embodiments, the user is able to more easily manage the alignment and arrangement of windows within the display area saving the user time and effort. In one example, assuming that the first and second windows are paired

side-by-side, if second window is moved away from or toward the first window, the second window is separated from the first window. In another example, assuming that the first and second windows are paired side-by-side, if the second window is moved substantially parallel to the first window toward the top or bottom of the second window, the second window slides parallel to the first window and remains paired with the first window. In some embodiments, the parallel movement of the second window is bound by to a fourth edge of the first window, where the fourth edge of the first window is perpendicular to the first edge of the first window.

**[00313]** In some embodiments, while the first edge of the first window is paired with the second edge of the second window, the device detects (836) a second user input, via the input device, dragging a respective edge of the first window along the second edge of the second window, where the respective edge of the first window is perpendicular to the second edge of the second window. In response to detecting the second user input, the device resizes a dimension of the first window associated with the respective edge according to the second user input. As one example, Figures 5XX-5ZZ show a sequence in which the top edge 5164b of the window 5160 is dragged along the left edge 5174a of the window 5170. In this example, a second dimension (e.g., the height) of the window 5160 is expanded from a value 5177a to a value 5177b, where the value 5177b is greater than the value 5177a. According to some embodiments, if the second user input drags an edge of the second window that is perpendicular to the first edge of the first window in a direction parallel to the first edge of the first window, the second window is resized.

**[00314]** In some embodiments, the resized dimension of the first window is constrained (838) by a third edge of the second window, and the third edge of the second window is perpendicular to the second edge of the second window. As one example, Figures 5XX-5ZZ show a sequence in which the top edge 5164b of the window 5160 is dragged along the left edge 5174a of the window 5170. In this example, the movement off the top edge 5164b of the window 5160 is constrained by the line 5178a associated with the top edge 5174b of the window 5170. In some embodiments, the parallel resizing is not constrained by the third edge of the second window.

**[00315]** In some embodiments, in response to detecting the first user input, and in accordance with a determination that the first user input satisfies one or more pairing criteria and that the first window is overlapping the second window, the device continues (840) the

movement of the first window based on the first user input and displaying the first window at least partially overlapping the second window. For example, there is a non-zero distance between the first and second windows. Furthermore, the first and second edges are not both bottom edges of their respective windows, and the first and second edges are not both top edges of their respective windows. As such, edges of windows that are being approached from inside the window cannot be paired with such as edges where the edge of the first window is already overlapping the second window when it is approaching the edge of the second window. For example, Figures 5OO-5PP show a sequence in which the right edge 5124a of the window 5120 does not pair with the right edge 5134a of the window 5130 because the window 5120 partially overlaps the window 5130 even though the pairing criteria are satisfied (e.g., the angle criterion and the velocity criterion). As such, according to some embodiments, the user is able to more easily manage the alignment and arrangement of windows within the display area saving the user time and effort.

**[00316]** In some embodiments, in response to detecting the first user input, and in accordance with a determination that the first user input satisfies one or more pairing criteria and that the second edge of the second window is occluded within the display area, the device continues (842) the movement of the first window based on the first user input and displaying the first window at least partially overlaps the second window. In some embodiments, edges of windows that are hidden in the user interface, such as windows that are occluded by other windows, cannot be paired with. As one example, Figures 5HHH-5JJJ show a sequence in which the left edge 5214a of the window 5210 does not pair with the right edge 5234a of the window 5230 because the right edge 5234a of the of the window 5230 is partially occluded by the window 5220 even though the pairing criteria are satisfied (e.g., the angle criterion and the velocity criterion). As another example, Figures 5KKK-5MMM show a sequence in which the left edge 5254a of the window 5250 does not pair with the right edge 5264a of the window 5260 because the right edge 5264a of the window 5260 incident the movement vector 5256 is occluded by the window 5270. As such, according to some embodiments, the user is able to more easily manage the alignment and arrangement of windows within the display area saving the user time and effort.

**[00317]** It should be understood that the particular order in which the operations in Figures 8A-8E have been described is merely example and is not intended to indicate that the described order is the only order in which the operations could be performed. One of ordinary

skill in the art would recognize various ways to reorder the operations described herein. Additionally, it should be noted that details of other processes described herein with respect to other methods described herein (e.g., methods 900 and 1000) are also applicable in an analogous manner to method 800 described above with respect to Figures 8A-8E. For example, the user interface objects and focus selectors described above with reference to method 800 optionally have one or more of the characteristics of the user interface objects and focus selectors described herein with reference to other methods described herein (e.g., methods 900 and 1000). For brevity, these details are not repeated here.

**[00318]** Figures 9A-9D illustrate a flow diagram of a method 900 of resizing windows in accordance with some embodiments. The method 900 is performed at an electronic device (e.g., the portable multifunction device 100 in Figure 1A, or the device 300 in Figure 3) with a one or more processors, non-transitory memory, a display, and an input device. In some embodiments, the display is a touch-screen display and the input device is on or integrated with the display. In some embodiments, the display is separate from the input device. Some operations in method 900 are, optionally, combined and/or the order of some operations is, optionally, changed.

**[00319]** As described below, the method 900 provides an intuitive way to resize windows. The method reduces the cognitive burden on a user when resizing windows, thereby creating a more efficient human-machine interface. For battery-operated electronic devices, enabling a user to resize windows faster and more efficiently conserves power and increases the time between battery charges.

**[00320]** The device displays (902), on the display, a first window in a display area. For example, the first window is rectangular with four edges. As one example, Figure 6A shows a window 610 with a left edge 614a, a top edge 614b, a right edge 614c, and a bottom edge 614d displayed within the display area 601. In this example, a first dimension (e.g., the width) of the window 610 has a value 616a, and a second dimension (e.g., the height) of the window 610 has a value 618a.

**[00321]** The device detects (904) a first user input, via the input device, associated with one or more edges of the first window. For example, the first user input includes a selection followed by movement such as a click and drag gesture on an edge or corner of the first window with the focus selector. In another example, the first user input includes a stationary

input such as a single or double click on an edge or corner of the first window with the focus selector.

**[00322]** In response to detecting the first user input, and in accordance with a determination that the first user input corresponds to a first input type (e.g., dragging an edge of the first window), the device resizes (906) one or more dimensions of the first window that correspond to the one or more edges of the first window based on a movement vector (e.g., distance and direction) associated with the first user input. As one example, click on the right edge of the first window and drag to resize the width of the first window. As another example, click on the corner of the first window and drag to resize the height and width of the first window. For example, Figures 6E-6G show a sequence in which the first and second dimensions of the window 610 are resized in response to a click and drag gesture on a corner associated with the intersection of the top edge 614b and the right edge 614c of the window 610. In this example, in Figures 6E-6F, the first dimension (e.g., the width) of the window 610 is increased from the value 616a to the value 616c, and the second dimension (e.g., the height) of the window 610 is increased from the value 618a to the value 618c. Continuing with this example, in Figures 6F-6G, the first dimension (e.g., the width) of the window 610 is increased from the value 616c to the value 616d, and the second dimension (e.g., the height) of the window 610 is increased from the value 618c to the value 618d. As such, according to some embodiments, the user is able to more easily manage the resizing of windows within the display area saving the user time and effort.

**[00323]** In some embodiments, the first input type corresponds to (908) an input that includes a selection followed by movement. In some embodiments, when the first user input corresponds to the first input type, the first user input includes a selection followed by movement such as a click and drag gesture on an edge of the first window with the focus selector. In some embodiments, when the first user input corresponds to the first input type, the first user input includes a selection followed by movement such as a click and drag gesture on a corner of the first window with the focus selector.

**[00324]** In some embodiments, resizing the one or more dimensions of the first window that correspond to the one or more edges of the first window includes (910): in accordance with a determination that the first user input satisfies one or more expansion criteria, resizing one dimension of the first window to two parallel edges of the display area; and, in accordance

with a determination that the first user input does not satisfy the one or more expansion criteria, resizing the one dimension of the first window to one edge of the display area. For example, an edge of the window is dragged toward an edge of display area based on a magnitude of a first portion of a gesture (e.g., the portion of the dragging gesture to the edge of the display area). In some embodiments, if the expansion criteria are met for a second portion of the gesture (e.g., the portion of the dragging gesture at the edge of the display area), the opposite edge of the window is moved toward the opposite edge of the display area. In some embodiments, if the expansion criteria are not met for the second portion of the gesture, forgo moving the opposite edge of the window to the opposite edge of the display area. In some embodiments, the expansion criteria are satisfied if the dragging gesture is held at the edge of the display area for a threshold duration. In some embodiments, the expansion criteria are satisfied when the magnitude of dragging gesture over the edge of the display area is greater than or equal to a threshold distance. As such, according to some embodiments, the user is able to more easily resize windows within the display area saving the user time and effort.

**[00325]** For example, the right edge of the window is dragged to the right edge of the display area and held there for X seconds. If X is greater than the time threshold, move the left edge of the window to the left edge of the display area. However, if X is less than the time threshold, maintain the left edge of the window in its position prior to the first user input. As one example, Figures 6H-6J show a sequence in which the right edge 624a of the window 620 is dragged to the right edge 606d of the display area 601. As such, a dimension (e.g., the width) of the window 620 is increased from the value 626a to the value 626c in a first direction (e.g., left-to-right). Continuing with this example, Figures 6J-6I show a sequence in which left edge 624b of the window 620 is moved to the right edge 634a of the window 630 when the expansion criteria are satisfied (e.g., the focus selector 602 is held at the right edge 606d of the display area 601 for X seconds). As such, the dimension (e.g., the width) of the window 620 is increased from the value 626c to the value 626d in a second direction (e.g., right-to-left).

**[00326]** In some embodiments, resizing the one or more dimensions of the first window that correspond to the one or more edges of the first window includes (912): in accordance with a determination that the first user input satisfies one or more expansion criteria, resizing a first dimension of the first window to a first set of two parallel edges of the display area and



resizing a second dimension of the first window to a second set of parallel edges of the display area, where the first and second sets of parallel edges of the display area are distinct; and, in accordance with a determination that the first user input does not satisfy the one or more expansion criteria, resizing the first dimension of the first window to a first edge of the display area and the second dimension of the first window to a second edge of the display area.

**[00327]** In some embodiments, a magnitude of the movement vector associated with the first user input is (914) less than a distance between the one or more edges of the first window and one or more corresponding edges of the display area, and the one or more edges of the first window are not co-located with the one or more corresponding edges of the display area after resizing the one or more dimensions of the first window that correspond to the one or more edges of the first window based on the movement vector (e.g., distance and direction) associated with the first user input. As one example, Figures 6E-6G show a sequence in which the first and second dimensions of the window 610 are resized in response to a click and drag gesture on a corner associated with the intersection of the top edge 614b and the right edge 614c of the window 610. In this example, after resizing the window 610, the top edge 614b of the window 610 is not co-located with the top edge 606a of the display area 601, and the right edge 614c of the window 610 is not co-located with the right edge 606d of the display area 601.

**[00328]** In response to detecting the first user input, and in accordance with a determination that the first user input corresponds to a second input type (e.g., a stationary input such as a single or double click on an edge or corner of the first window), the device moves (916) the one or more edges of the first window (e.g., so as to expand the window) to one or more corresponding edges of the display area while maintaining respective one or more opposite edges of the first window. As one example, if the user double clicks on the top edge of the first window, the top edge of the first window moves to a top edge of the display area in order to increase the height of the first window. As another example, if the user double clicks on the top-right corner of the first window, the top and right edges of the first window move the top and right edges of the display area. In some embodiments, a double click inside of the chrome of the first window causes the window to expand in all directions (e.g., go full screen). In some embodiments, a double click inside of the chrome of the first window causes the window to expand in both vertical directions. As such, according to some embodiments,

the user is able to more easily the resize windows within the display area saving the user time and effort.

**[00329]** In some embodiments, the second input type corresponds to (918) a stationary input. In some embodiments, when the first user input corresponds to the second input type, the first user input includes a stationary input such as a single or double click on an edge of the first window. In some embodiments, when the first user input corresponds to the second input type, the first user input includes a stationary input such as a single or double click on a corner of the first window.

**[00330]** In some embodiments, moving the one or more edges of the first window to one or more corresponding edges of the display area includes (920) moving a single edge of the first window to a corresponding edge of the display area in accordance with a determination that the first user input corresponds to the single edge of the first window. As one example, Figures 6L-6M show a sequence in which the right edge 644a of the window 640 moves to the right edge 606d of the display area 601 in response to the second input type (e.g., the stationary input) on the right edge 644a of the window 640. As such, a first dimension (e.g., the width) of the window 640 increases from the value 646a to the value 646b. As another example, Figures 6N-6O show a sequence in which the top edge 644b of the window 640 moves to the top edge 606a of the display area 601 in response to the second input type (e.g., the stationary input) on the top edge 644b of the window 640. As such, a second dimension (e.g., the height) of the window 640 increases from the value 648a to the value 648b. As such, according to some embodiments, the user is able to more easily resize a dimension of a window in one direction saving the user time and effort when managing the alignment and arrangement of windows within the display area.

**[00331]** In some embodiments, the device (922): after moving the single edge of the first window to the edge of the display area that corresponds to the single edge of the first window, detecting a second user input, via the input device, associated with the single edge of the first window; and, in response to detecting the second user input, and in accordance with a determination that the second user input corresponds to the second input type (e.g. a stationary input such as a double click), moving the single edge of the first window to a position at which the single edge was located on the display prior (e.g., immediately prior) detecting to the first user input. For example, after moving the top edge of the first window

to the top edge of the display area due to a first double click on the top edge of the first window, if the user double clicks on the top edge of the first window for a second time, the top edge of the first window moves to its former position prior to the first double click. As such, according to some embodiments, the user is able to more easily revert a dimension of a window to a former size in one direction saving the user time and effort when managing the alignment and arrangement of windows within the display area.

**[00332]** For example, Figures 6P-6Q show a sequence in which the right edge 654a of the window 650 moves to the left edge 664a of the window 660 in response to the second input type (e.g., the stationary input) on the right edge 654a of the window 650. As such, a first dimension (e.g., the width) of the window 650 increases from the value 656a to the value 656b. Continuing with this example, Figures 6Q-6R show a sequence in which the right edge 654a of the window 650 moves to its former position in Figure 6P in response to the second input type (e.g., the stationary input) on the right edge 654a of the window 650. As such, a first dimension (e.g., the width) of the window 650 decreases from the value 656b to the value 656a.

**[00333]** In some embodiments, prior to detecting the first user input, a second window is displayed (924) within the display area between the first window and the edge of the display area that corresponds to the single edge of the first window, and, in accordance with a determination that first user input corresponds to the single edge of the first window and the second input type (e.g. a stationary input such as a double click), the movement of the single edge of the first window to the corresponding edge of the display area is bound by an edge of the second window that is parallel to the single edge of the first window. For example, the second window is located between the top edge of the first window and the top edge of the display area. As such, if the user double clicks on the top edge of the first window, move the top edge of the first window to the bottom edge of the second window. In some embodiments, if the second window is partially occluded ignore this behavior. For example, Figures 6P-6Q show a sequence in which the right edge 654a of the window 650 moves to the left edge 664a of the window 660 in response to the second input type (e.g., the stationary input) on the right edge 654a of the window 650. As such, the movement of the right edge 654a of the window 650 is constrained by the window 660, which intervenes between the right edge 654a of the window 650 and the right edge 606d of the display area 601.

**[00334]** In some embodiments, moving the one or more edges of the first window to one or more corresponding edges of the display area includes (926) moving two edges of the first window that are adjacent to a corner of the first window to two corresponding edges of the display area in accordance with a determination that the first user input corresponds to the corner of the first window. In some embodiments, the two edges of the first window intersect (or are adjacent to) one another. Similarly, the corresponding two edges of the display area intersect (or are adjacent to) one another. As such, according to some embodiments, the user is able to more easily resize a first dimension of a window in one direction and a second dimension of the window in one direction saving the user time and effort when managing the alignment and arrangement of windows within the display area.

**[00335]** As one example, Figures 6A-6B show a sequence in which the left edge 614a of the window 610 moves to the left edge 606b of the display area 601 and the top edge 614b of the window 610 moves to the top edge 606a of the display area 601 in response to the second input type (e.g., the stationary input) on the corner of the window 610 associated with the intersection of the left edge 614a and the top edge 614b. As such, the first dimension (e.g., the width) of the window 610 increases from a value 616a to a value 616b, and the second dimension (e.g., the height) of the window 610 increases from a value 618a to a value 618b.

**[00336]** In some embodiments, after moving two edges of the first window that are adjacent to the corner of the first window to the two corresponding edges of the display area, the device detects (928) a second user input, via the input device, associated with at least one edge of the first window. In response to detecting the second user input, and in accordance with a determination that the second user input corresponds to a single edge of the first window and in accordance with a determination that the second user input corresponds to the second input type (e.g. a stationary input such as a double click), the device moves the single edge of the first window to a position at which the single edge was located on the display prior (e.g., immediately prior) detecting to the first user input. In response to detecting the second user input, and in accordance with a determination that the second user input corresponds to a corner of the first window and in accordance with a determination that the second user input corresponds to the second input type (e.g. a stationary input such as a double click), the device moves the two edges of the first window that correspond to the corner of the first window to position at which the two edges were located on the display prior (e.g., immediately prior) detecting to the first user input. As such, according to some embodiments,

the user is able to more easily revert one or more dimensions of a window to a former size in one direction saving the user time and effort when managing the alignment and arrangement of windows within the display area.

**[00337]** For example, after the top edge of the first window moves to the top edge of the display area and the left edge of the first window to the left edge of the display area due to a first double click on the top-left edge of the first window, if the user double clicks on the top-left edge of the first window for a second time, the top and left edges of the first window move back to their former positions prior to the first double click. As one example, Figures 6C-6D show a sequence in which the top edge 614b and the left edge 614a of the window 610 move to their former positions in Figure 6A in response to the second input type (e.g., the stationary input) on the corner the window 610 associated with the intersection of the top edge 614b and the left edge 614a of the window 610. As such, the first dimension (e.g., the width) of the window 610 decreases from the value 616b to the value 616a, and the second dimension (e.g., the height) of the window 610 decreases from the value 618b to the value 618a.

**[00338]** For example, after the top edge of the first window moves to the top edge of the display area and the left edge of the first window to the left edge of the display area due to a first double click on the top-left edge of the first window, if the user double clicks on the top edge of the first window for a second time, the top edge of the first window moves back to its former positions prior to the first double click and the left edge of the first window maintains its position after the first double click. As one example, Figures 6V-6W show a sequence in which the right edge 6104a of the window 6100 moves to the right edge 6116a of the window 6110 and the bottom edge 6104b of the window 6100 moves to the bottom edge 606c of the display area 601 in response to the second input type (e.g., the stationary input) on the corner of the window 610 associated with the intersection of the right edge 6104a and the bottom edge 6104b. As such, the first dimension (e.g., the width) of the window 6100 increases from a value 6106a to a value 6106b, and the second dimension (e.g., the height) of the window 6100 increases from a value 6108a to a value 6108b. Continuing with this example, Figures 6X-6Y show a sequence in which the right edge 6104a of the window 6100 move to its former position in Figure 6V and the bottom edge 6104b maintains its position in response to the second input type (e.g., the stationary input) on the right edge

6104a of the window 6100. As such, the first dimension (e.g., the width) of the window 6100 decreases from the value 6106b to the value 6106a.

**[00339]** In some embodiments, prior to detecting the first user input, a second window is displayed (930) within the display area between the first window and at least one of the two corresponding edges of the display area, and, in accordance with a determination that first user input corresponds to the corner of the first window and in accordance with a determination that second user input corresponds to the second input type (e.g. a stationary input such as a double click), the movement of at least one of the two edges of the first window that are adjacent to the corner of the first window to two corresponding edges of the display area is bound by at least one edge of the second window that is parallel to the two edges of the first window. For example, Figures 6V-6W show a sequence in which the right edge 6104a of the window 6100 moves to the right edge 6116a of the window 6110 and the bottom edge 6104b of the window 6100 moves to the bottom edge 606c of the display area 601 in response to the second input type (e.g., the stationary input) on the corner of the window 610 associated with the intersection of the right edge 6104a and the bottom edge 6104b. As such, the movement of the right edge 6104a of the window 6100 is constrained by the window 6110, which intervenes between the right edge 6104a of the window 6100 and the right edge 606d of the display area 601.

**[00340]** In some embodiments, in response to detecting the first user input, and in accordance with a determination that the first user input corresponds to a third input type, the device moves (932) one or more edges of the first window to one or more corresponding edges of the display areas. In some embodiments, the third user input type corresponds to a stationary input within a predefined region of the first window. For example, when the first user input corresponds to the third input type the first user input includes a double or single click on the chrome region of the first window. In one example, a first dimension (e.g., the height) of the first window expands to two parallel edges of the display area (e.g., both vertical directions) in response to the third input type. In another example, a second dimension (e.g., the width) of the first window expands to two parallel edges of the display area (e.g., both horizontal directions) in response to the third input type. In yet another example, the dimensions of the first window expand to fill the display area (e.g., full screen mode) in response to the third input type. As such, according to some embodiments, the user is able to

more easily manage the resizing of windows within the display area saving the user time and effort.

**[00341]** It should be understood that the particular order in which the operations in Figures 9A-9D have been described is merely example and is not intended to indicate that the described order is the only order in which the operations could be performed. One of ordinary skill in the art would recognize various ways to reorder the operations described herein. Additionally, it should be noted that details of other processes described herein with respect to other methods described herein (e.g., methods 800 and 1000) are also applicable in an analogous manner to method 900 described above with respect to Figures 9A-9D. For example, the user interface objects and focus selectors described above with reference to method 900 optionally have one or more of the characteristics of the user interface objects and focus selectors described herein with reference to other methods described herein (e.g., methods 800 and 1000). For brevity, these details are not repeated here.

**[00342]** Figures 10A-10C illustrate a flow diagram of a method 1000 of providing tabbed window functionality in accordance with some embodiments. The method 1000 is performed at an electronic device (e.g., the portable multifunction device 100 in Figure 1A, or the device 300 in Figure 3) with a one or more processors, non-transitory memory, a display, and an input device. In some embodiments, the display is a touch-screen display and the input device is on or integrated with the display. In some embodiments, the display is separate from the input device. Some operations in method 1000 are, optionally, combined and/or the order of some operations is, optionally, changed.

**[00343]** As described below, the method 1000 provides an intuitive way to provide tabbed window functionality. The method reduces the cognitive burden on a user when providing tabbed window functionality, thereby creating a more efficient human-machine interface. For battery-operated electronic devices, enabling a user to utilize tabbed window functionality faster and more efficiently conserves power and increases the time between battery charges.

**[00344]** The device displays (1002), on the display, a first window associated with a first application within a display area. In some embodiments, the first window is currently in the foreground or “in focus” within the display area. As one example, Figure 7A shows a window 730 associated with application A operating in windowed mode (e.g., non-full screen

mode). In Figure 7A, the window 730 is displayed in the foreground as indicated by the shading of the chrome region 732a. As another example, Figure 7N shows a window 790 associated with application C operating in full screen mode (e.g., non-windowed mode). In Figure 7N, the window 790 is displayed in the foreground as indicated by the shading of the chrome region 792a.

**[00345]** The device detects (1004) a first user input, via the input device, that corresponds to a request to add a second window associated with the first application.

**[00346]** In some embodiments, the first user input corresponds to (1006) selection of an affordance within the first window that causes an instruction to be sent to the first application to generate a new window associated with the first application. For example, with reference to Figure 7A, the window 730 includes an affordance (not shown) provided to open a new window associated with application A. As another example, with reference to Figure 7C, the drop-down menu 746 includes a new window affordance 748a provided to open a new window associated with application A.

**[00347]** In some embodiments, the first user input corresponds to (1008) a combination of one or more keystrokes that causes an instruction to be sent to the first application to generate a new window associated with the first application. For example, the combination of one or more keystrokes that causes an instruction to be sent to the application to generate a new window associated with the application is a “Ctrl+N” combination. As one example, Figures 7A-7B show a sequence in which a new window 740 is displayed within the display area 701 in response to a “Ctrl+N” keystroke combination issued to application A while application A is operating in windowed mode. As another example, Figures 7N-7O show a sequence in which a merged window 795 is created with a tab 794a for the previous window 790 and new tab 794b is displayed in response to a “Ctrl+N” keystroke combination issued to application C while application C is operating in full screen mode.

**[00348]** In some embodiments, a combination of one or more keystrokes that causes an instruction to be sent to the first application to generate a new tab associated with the first application results in a new window associated with the first application (e.g., “Ctrl+T”). In some embodiments, if a user input corresponds to a combination of one or more keystrokes that causes an instruction to be sent to the first application to generate a new tab associated with the first application plus a modifier key (e.g., “Ctrl+Opt+T”), a new window associated



with the first application is displayed. In some embodiments, if a user input corresponds to a combination of one or more keystrokes that causes an instruction to be sent to the first application to generate a new window associated with the first application plus a modifier key (e.g., “Ctrl+Opt+N”), a new tab associated with the first application is displayed.

**[00349]** In response to detecting the first user input, and in accordance with a determination that the first window is displayed within the display area in full screen mode, the device adds (1010) the second window as a new tab within a tab bar associated with the first window. In some embodiments, the first window becomes a background tab, and the new tab associated with the second window is displayed in the foreground. In some embodiments, the new tab associated with the second window is added as a background tab and the first window remains in the foreground. For example, Figures 7N-7O show a sequence in which a merged window 795 is created with a tab 794a for the previous window 790 and new tab 794b is displayed in response to a new window command (e.g., a “Ctrl+N” keystroke combination) issued to application C while application C is operating in full screen mode. Thus, according to some embodiments, tabbing functionality is enabled by the operating system for applications without native tab functionality. This, for example, provides the user with a more intuitive interface that is less cluttered.

**[00350]** In some embodiments, adding the second window as the new tab within the tab bar associated with the first window includes (1012) displaying the second window as a tab within the second window as the new tab within the tab bar associated with the first window after the second application generates the second window. In some embodiments, the first application does not have native tabbing functionality. Thus, the operating system treats the new window as a virtual tab and overlays the tab bar on the first and second windows independent of the first application. As such, for example, in Figure 7O, the windows that correspond to the tabs 794a and 794b are full screen windows stacked on top of one another such that the foreground window is displayed on the top of the stack (e.g., the new window associated with the tab 794b in Figure 7O). According to some embodiments, the tabs are displayed within a virtual tab bar superimposed on the new foreground window by the operating system. Thus, in some embodiments, tabbing functionality is enabled by the operating system for applications without native tab functionality. This, for example, provides the user with a more intuitive interface that is less cluttered.

**[00351]** In some embodiments, adding the second window as a new tab within a tab bar associated with the first window includes (1014): determining whether a global tabbed window functionality is enabled; and, in accordance with the determination that the first window is displayed within the display area in full screen mode and in accordance with a determination that the global tabbed window setting is enabled, adding the second window as a new tab within a tab bar associated with the first window. In some embodiments, the operating system includes a global tab setting that can be adjusted to enable tabbed windows to be created manually, to always be created, or to only be created when an application is operating in full screen mode. For example, Figures 7E-7G show a sequence in which the global tab setting is changed from “Manual” to “Always.” In some embodiments, the tabs preference associated with the picker menu 762d in Figures 7E-7G applies to applications without native tabbing functionality. This, for example, provides the user with a more intuitive interface that is less cluttered. In some embodiments, the tabs preference associated with the picker menu 762d in Figures 7E-7G applies to all applications. In some embodiments, the tabs preference associated with the picker menu 762d applies in Figures 7E-7G to all application but ones included on an opt-out list.

**[00352]** As shown in Figure 7F, the picker menu 762d includes a “Manual” option 764a, where a new window operation issued to the foreground application opens a window associated with the foreground application and a new tab operation issued to the foreground application opens a new tab associated with the foreground application when the foreground application has native tabbing functionality. In some embodiments, entry of a modifier key plus new window key combination overrides the default setting. For example, open in tabbed window associated with the foreground application if default is to open in a new window (e.g., the “Manual” behavior). As another example, open in a new window associated with the foreground application if default is to open in tabbed window (e.g., the “Always” behavior). In some embodiments, entry of a modifier key plus clicking on a dock icon overrides the default setting. As one example, open in tabbed window for the application that corresponds to the dock icon if default is to open in a new window (e.g., the “Manual” behavior). As another example, open in a new window for the application that corresponds to the dock icon if default is to open in tabbed window (e.g., the “Always” behavior).

**[00353]** As shown in Figure 7F, the picker menu 762d also includes an “Always” option 764b, where a new window operation issued to the foreground application opens a new

tab associated with the foreground application and (optionally) a new tab operation issued to the foreground application opens a new window associated with the foreground application. As shown in Figure 7F, the picker menu 762d further includes a “Full Screen Only” option 764c, where a new window operation issued to the foreground application while in full screen mode opens a new tab associated with the foreground application and (optionally) a new tab operation issued to the foreground application while in full screen mode opens a new window associated with the foreground application.

**[00354]** As one example, the “Always” behavior applies to Figures 7H-7M after changing the global tab setting from “Manual” to “Always” in Figures 7E-7G. As another example, the “Manual” behavior applies to Figures 7A-7D before changing the global tab setting from “Manual” to “Always” in Figures 7E-7G. As another example, the “Full Screen Only” behavior applies to Figures 7N-7O.

**[00355]** In some embodiments, the first application is not included (1016) on an opt-out list for the global tabbed window functionality. In some embodiments, the global tab setting applies to all application that are not included on an opt-out list. For example, the opt-out list includes applications with native tab functionality, user specified application, and/or application developed by the same developer as the operating system. Thus, according to some embodiments, applications with native tab functionality may be exempted from the global tab setting thereby avoiding potentially duplicitous tabbing functionality.

**[00356]** In some embodiments, after detecting the first user input, the device detects (1018) a subsequent user input, via the input device, to add a third window associated with a second application. In response to detecting the subsequent user input, and in accordance with a determination that the first window is displayed within the display area in full screen mode, the device adds the third window as a new tab in a tab bar associated with the first window. In response to detecting the subsequent user input, and in accordance with a determination that the first window is displayed within the display area in windowed mode, the device displays the third window as a separate window within the display area. For example, with reference to Figures 7N-7O, another tab would be added to the merged window 795 if a subsequent new window command was issued to a different application (not shown). For example, with reference to Figures 7A-7B, another window would be added within the display area 701 if a subsequent new window command was issued to a different application

(not shown). Thus, according to some embodiments, tabbing functionality is enabled across multiple applications. For example, a merged window with tabs for more multiple applications provides the user with a more intuitive interface that is less cluttered.

**[00357]** In response to detecting the first user input, and in accordance with a determination that the first window is displayed within the display area in windowed mode, the device displays (1020) the second window separate from the first window within the display area. In some embodiments, the second window is positioned behind the first window, and the first window remains in the foreground or “in focus”. In some embodiments, the second window is overlaid on the first window, and the second window is the foreground window or “in focus”. As one example, Figures 7A-7B show a sequence in which a new window 740 is displayed within the display area 701 in response to a new window command (e.g., a “Ctrl+N” keystroke combination) issued to application A while application A is operating in windowed mode.

**[00358]** In some embodiments, after displaying the second window separate from the first window within the display area, the device detects (1022) a second user input, via the input device, to merge the first and second windows into a single tabbed window, and, in response to detecting the second user input, the device replaces display of the separate first and second windows with a merged window that includes a tab bar with a first tab associated with the first window and a second tab associated with the second window. According to some embodiments, generation of tabbed windows from multiple open windows is handled by the operating system. For example, the operating system hides open windows other than a “top” open window associated with a foreground tab and moves/resizes the hidden windows when they are requested to be displayed so that they are displayed on top of one another. Thus, in some embodiments, tabbing functionality is enabled by the operating system for applications without native tab functionality. This, for example, provides the user with a more intuitive interface that is less cluttered.

**[00359]** In some embodiments, the application is not aware of the fact that its windows are being displayed in a single tabbed window. According to some embodiments, the application is able to perform operations with respect to the windows as it normally would, treating them as though they were just stacked on top of each other. For example, to improve

performance, the application is optionally asked to resize windows only when the windows are moved to the foreground of the tabbed window.

**[00360]** For example, Figures 7B-7D show a sequence in which a plurality of windows 710, 720, 730, and 740 associated with application A are merged into a single merged window 750 with tabs 756a, 756b, 756c, and 756d corresponding to the plurality of windows 710, 720, 730, and 740. In some embodiments, the “create tabbed window” affordance 748c within the drop-down menu 746 in Figure 7C enables windows associated with applications that do not have native tab functionality to be displayed in a tabbed window. As such, for example, open windows 710, 720, 730, and 740 are resized to a same size and stacked on top of one another such that the foreground window is displayed on the top of the stack (e.g., the window 740 associated with the tab 756d). In this example, the tabs 756a, 756b, 756c, and 756d are displayed within a virtual tab bar 752c, which is superimposed on the top window of the stack of windows by the operating system. For example, if another tab is selected within the tab bar 752c, a window associated with selected tab is moved to the top of the stack of windows.

**[00361]** According to some embodiments, if a close tab command is issued to one of the tabs 756a, 756b, 756c, and 756d, the operating system issues a command to application A to close a window that corresponds to the tab. According to some embodiments, if a close/exit command is issued to the merged window 750, the operating system issues a command to application A to close each of the windows 710, 720, 730, and 740 that correspond to the tabs 756a, 756b, 756c, and 756d in the merged window 750.

**[00362]** According to some embodiments, if one of the tabs 756a, 756b, 756c, and 756d is dragged out of the tab bar 752c, a window corresponding to the tab is displayed separate from the stack of windows (e.g., as shown in Figures 7L-7M). In some embodiments, the tabs 756a, 756b, 756c, and 756d may be dragged out of the merged window 750 and into a spaces bar associated with the top edge of the display area 701. According to some embodiments, if a window is dragged into the merged window 750, a new tab is added to the merged window 750 as either a foreground or background tab (e.g., as shown in Figures 7J-7K).

**[00363]** In some embodiments, the tab bar is displayed (1024) in a chrome region of the merged window, and where the tab bar is generated and controlled independent of the first application. In some embodiments, the first application does not have native tabbing functionality. Thus, according to some embodiments, the operating system treats the first and

second windows as virtual tabs and displays the tab bar independent of the first application. This, for example, provides the user with a more intuitive interface that is less cluttered. For example, with reference to Figure 7D, the tabs 756a, 756b, 756c, and 756d are displayed within a virtual tab bar 752c superimposed on the top window of the stack of windows by the operating system. In this example, the virtual tab bar 752c is superimposed on the chrome region of the window 740 associated with the foreground tab 756d. As such, in Figure 7D, the window 740 is the top window in the stack of windows 710, 720, 730, and 740.

**[00364]** In some embodiments, after displaying the merged window, the device detects (1026) a third user input, via the input device, to close the merged window, and, in response to detecting the third user input, the device sends window close instructions to the first application to close the first and second windows. For example, with reference to Figure 7D, if a close/exit command (e.g., selection of a close affordance in the chrome region 752a) is issued to the merged window 750, the operating system issues a command to application A to close each of the windows 710, 720, 730, and 740 that correspond to the tabs 756a, 756b, 756c, and 756d in the merged window 750 (not shown).

**[00365]** In some embodiments, after displaying the merged window, the device detects (1028) a third user input, via the input device, dragging a third window separate from the merged window into the tab bar of the merged window, where the third window is associated with a second application; and, in response to the third user input, the device adds a new tab associated with the third window to the tab bar of the merged window. For example, the third window includes one or more tabs corresponding to windows of the second application. For example, Figures 7J-7K show a sequence in which the window 770 associated with application A is added as a new foreground tab 764c to the merged window 765 that includes the tabs 764a and 764b associated with application B. As such, in Figure 7K, the merged window 765 includes the tabs 764a and 764b associated with application B and the foreground tab 764c associated with application A. Thus, according to some embodiments, the tabbing functionality provided by operating system operates similar to application with native tabbing functionality.

**[00366]** In some embodiments, after displaying the merged window, the device detects (1030) a third user input, via the input device, dragging the merged window into a third window separate from the merged window, where the third window is associated with a

second application, and, in response to the third user input, the device adds a new tab associated with the third window to the tab bar of the merged window. In some embodiments, a virtual tab bar is overlaid on the third window and tabs are created within the new virtual tab bar for the third window and the tabs of the merged window. For example, with reference to Figure 7J, the merged window 765 is dragged into the chrome region 772a of the window 770 (not shown). As a result, continuing with this example, a virtual tab bar with a tab corresponding to the window 770 and the tabs 764a and 764b is overlaid on a merged window (not shown). Thus, according to some embodiments, the tabbing functionality provided by operating system operates similar to application with native tabbing functionality. This, for example, provides the user with a more intuitive interface that is less cluttered.

**[00367]** In some embodiments, after adding the new tab associated with the third window to the tab bar of the merged window, the device detects (1032) a fourth user input, via the input device, to close the merged window, and, in response to detecting the fourth user input, the device sends a first window close instruction to the first application to close the first and second windows and a second window close instruction to the second application to close the third window. For example, with reference to Figure 7K, if a close/exit command (e.g., selection of a close affordance in the chrome region 767a) is issued to the merged window 765, the operating system issues a command to application A to close each of the windows that correspond to the tabs 764a and 764b and the window that corresponds to the tab 764c (not shown).

**[00368]** It should be understood that the particular order in which the operations in Figures 10A-10C have been described is merely example and is not intended to indicate that the described order is the only order in which the operations could be performed. One of ordinary skill in the art would recognize various ways to reorder the operations described herein. Additionally, it should be noted that details of other processes described herein with respect to other methods described herein (e.g., methods 800 and 900) are also applicable in an analogous manner to method 1000 described above with respect to Figures 10A-10C. For example, the user interface objects and focus selectors described above with reference to method 1000 optionally have one or more of the characteristics of the user interface objects and focus selectors described herein with reference to other methods described herein (e.g., methods 800 and 900). For brevity, these details are not repeated here.

**[00369]** In accordance with some embodiments, Figure 11 shows a functional block diagram of an electronic device 1100 configured in accordance with the principles of the various described embodiments. The functional blocks of the device are, optionally, implemented by hardware, software, firmware, or a combination thereof to carry out the principles of the various described embodiments. It is understood by persons of skill in the art that the functional blocks described in Figure 11 are, optionally, combined or separated into sub-blocks to implement the principles of the various described embodiments. Therefore, the description herein optionally supports any possible combination or separation or further definition of the functional blocks described herein.

**[00370]** As shown in Figure 11, an electronic device 1100 includes a display unit 1102 configured to display a user interface, one or more input units 1104 configured to receive user inputs, and a processing unit 1108 coupled to the display unit 1102 and the one or more input units 1104. In some embodiments, the processing unit 1108 includes: a display control unit 1110, an input detecting unit 1112, a pairing unit 1114, and an unpairing unit 1116.

**[00371]** The processing unit 1108 is configured to: enable display of (e.g., with the display control unit 1110), on the display unit 1102, a first window and a second window within a display area, the first window having a first edge parallel to a second edge of the second window; and detecting (e.g., with the input detecting unit 1112) a first user input, via the one or more input units 1103, moving the first edge of the first window toward the second edge of the second window. In response to detecting the first user input, and in accordance with a determination that the first user input satisfies one or more pairing criteria, the processing unit 1108 is further configured to pair (e.g., with the pairing unit 1114) the first edge of the first window to the second edge of the second window such that the first window stops moving in response to the first user input before it overlaps the second, where the one or more pairing criteria include a first pairing criterion that is met when the first input corresponds to movement of the first edge toward the second edge that deviates from a predefined axis by less than an angular threshold value. In response to detecting the first user input, and in accordance with a determination that the first user input does not satisfy the one or more pairing criteria, the processing unit 1108 is further configured to continue the movement (e.g., with the display control unit 1110) of the first window based on the first user input so that the first window at least partially overlaps the second window.



**[00372]** In some embodiments, the first user input corresponds to moving the first window within the display area by dragging the first window toward the second window.

**[00373]** In some embodiments, the first user input corresponds to resizing the first window within the display area by dragging the first edge of the first window toward the second window.

**[00374]** In some embodiments, a second pairing criterion of the one or more pairing criteria includes a velocity threshold value, and satisfying the second pairing criterion includes determining that a velocity associated with the first user input breaches the velocity threshold value.

**[00375]** In some embodiments, a third pairing criterion of the one or more pairing criteria includes a distance threshold value, and satisfying the third pairing criterion includes determining that the input corresponds to movement of the first edge of the window in a respective direction to the edge of the second window without corresponding to more than a threshold amount of movement in the respective direction.

**[00376]** In some embodiments, in response to detecting the first user input, and in accordance with a determination that the first user input satisfies one or more pairing criteria and that the first window is overlapping the second window, the processing unit 1108 is further configured to continue the movement (e.g., with the display control unit 1110) of the first window based on the first user input and enable display of (e.g., with the display control unit 1110) the first window at least partially overlapping the second window.

**[00377]** In some embodiments, in response to detecting the first user input, and in accordance with a determination that the first user input satisfies one or more pairing criteria and that the second edge of the second window is occluded within the display area, the processing unit 1108 is further configured to continue the movement (e.g., with the display control unit 1110) of the first window based on the first user input and enable display of (e.g., with the display control unit 1110) the first window at least partially overlaps the second window.

**[00378]** In some embodiments, while the first edge of the first window is paired with the second edge of the second window, the processing unit 1108 is further configured to detect (e.g., with the input detecting unit 1112) a second user input, via the one or more input units

1104, moving the first window away from the second window. In response to the second user input, the processing unit 1108 is further configured to unpair (e.g., with unpairing unit 1116) the first edge of the first window from the second edge of the second window and move (e.g., with the display control unit 1110) the first window according to a movement vector associated with the second user input.

**[00379]** In some embodiments, while the first edge of the first window is paired with the second edge of the second window, the processing unit 1108 is further configured to detect (e.g., with the input detecting unit 1112) a second component of the first user input moving the first window away from the second window. In response to the second component of the first user input and in accordance with a determination that a magnitude of the second component breaches a distance threshold, the processing unit 1108 is further configured to unpair (e.g., with unpairing unit 1116) the first edge of the first window from the second edge of the second window and move (e.g., with the display control unit 1110) the first window according to a movement vector associated with the second component of the first user input.

**[00380]** In some embodiments, while the first edge of the first window is paired with the second edge of the second window, the processing unit 1108 is further configured to detect (e.g., with the input detecting unit 1112) a second user input, via the one or more input units 1104, moving the first window toward the second edge of the second window. In response to detecting the second user input, and in accordance with a determination that the second user input satisfies one or more separation criteria, the processing unit 1108 is further configured to unpair (e.g., with unpairing unit 1116) the first edge of the first window from the second edge of the second window and move (e.g., with the display control unit 1110) the first window over the second window according to a movement vector associated with the second user input. In response to detecting the second user input, and in accordance with a determination that the second user input does not satisfy the one or more separation criteria, processing unit 1108 is further configured to maintain (e.g., with the pairing unit 1114) the pairing between the first edge of the first window and the second edge of the second window and forego moving the first window over the second window.

**[00381]** In some embodiments, moving the first window over the second window according to the movement vector associated with the second user input includes: in accordance with a determination that the second user input corresponds to moving a focus

selector over the second window, displaying an animation such that moving the first window over the second window is discontinuous; and, in accordance with a determination that the second user input does not correspond to moving the focus selector over the second window, foregoing displaying the animation such that moving the first window over the second window is continuous.

**[00382]** In some embodiments, while the first edge of the first window is paired with the second edge of the second window, the processing unit 1108 is further configured to detect (e.g., with the input detecting unit 1112) a second user input, via the one or more input units 1104, that corresponds to movement of the first edge relative to the second edge. In response to detecting the second user input, and in accordance with a determination that the second user input corresponds to movement of the first window such that the first edge of the first window moves over the second edge, the processing unit 1108 is further configured to delay (e.g., with the display control unit 1110) movement of the first window until the second user input has reached a movement threshold. In response to detecting the second user input, and in accordance with a determination that the second user input corresponds to movement of the first window such that the first edge of the first window moves away from the second edge, the processing unit 1108 is further configured to start (e.g., with the display control unit 1110) to move the first window before the second user input has reached the movement threshold.

**[00383]** In some embodiments, while the first edge of the first window is paired with the second edge of the second window, the processing unit 1108 is further configured to detect (e.g., with the input detecting unit 1112) a second user input, via the one or more input units 1104, moving the first window along the second edge of the second window. In response to detecting the second user input, and in accordance with a determination that the second user input satisfies one or more separation criteria, the processing unit 1108 is further configured to unpair (e.g., with unpairing unit 1116) the first edge of the first window from the second edge of the second window and move (e.g., with the display control unit 1110) the first window according to a movement vector associated with the second user input. In response to detecting the second user input, and in accordance with a determination that the second user input does not satisfy any of the one or more separation criteria, the processing unit 1108 is further configured to maintain (e.g., with the pairing unit 1114) the pairing between the first edge of the first window and the second edge of the second window and move (e.g., with

the display control unit 1110) the first window parallel to the second edge of the second window according to the second user input.

**[00384]** In some embodiments, the parallel movement of the first window is constrained by a third edge of the second window, and the third edge of the second window is perpendicular to the second edge of the second window.

**[00385]** In some embodiments, while the first edge of the first window is paired with the second edge of the second window, the processing unit 1108 is further configured to detect (e.g., with the input detecting unit 1112) a second user input, via the one or more input units 1104, moving the second window along the first edge of the first window. In response to detecting the second user input, and in accordance with a determination that the second user input satisfies one or more separation criteria, the processing unit 1108 is further configured to unpair (e.g., with unpairing unit 1116) the second edge of the second window from the first edge of the first window and move (e.g., with the display control unit 1110) the second window according to second user input. In response to detecting the second user input, and in accordance with a determination that the second user input does not satisfy any of the one or more of the separation criteria, the processing unit 1108 is further configured to maintain (e.g., with the pairing unit 1114) the pairing between the first edge of the first window and the second edge of the second window and move (e.g., with the display control unit 1110) the second window parallel to the first edge of the first window according to a movement vector associated with the second user input.

**[00386]** In some embodiments, while the first edge of the first window is paired with the second edge of the second window, the processing unit 1108 is further configured to detect (e.g., with the input detecting unit 1112) a second user input, via the one or more input units 1104, dragging a respective edge of the first window along the second edge of the second window, where the respective edge of the first window is perpendicular to the second edge of the second window. In response to detecting the second user input, the processing unit 1108 is further configured to resize (e.g., with the display control unit 1110) a dimension of the first window associated with the respective edge according to the second user input.

**[00387]** In some embodiments, the resized dimension of the first window is constrained by a third edge of the second window, and the third edge of the second window is perpendicular to the second edge of the second window.

**[00388]** In accordance with some embodiments, Figure 12 shows a functional block diagram of an electronic device 1200 configured in accordance with the principles of the various described embodiments. The functional blocks of the device are, optionally, implemented by hardware, software, firmware, or a combination thereof to carry out the principles of the various described embodiments. It is understood by persons of skill in the art that the functional blocks described in Figure 12 are, optionally, combined or separated into sub-blocks to implement the principles of the various described embodiments. Therefore, the description herein optionally supports any possible combination or separation or further definition of the functional blocks described herein.

**[00389]** As shown in Figure 12, an electronic device 1200 includes a display unit 1202 configured to display a user interface, one or more input units 1204 configured to receive user inputs, and a processing unit 1208 coupled to the display unit 1202 and the one or more input units 1204. In some embodiments, the processing unit 1208 includes: a display control unit 1210, an input detecting unit 1212, an input type determining unit 1214, and an expansion determining unit 1216.

**[00390]** The processing unit 1208 is configured to: enable display of (e.g., with the display control unit 1210), on the display unit 1202, a first window in a display area; and detect (e.g., with the input detecting unit 1212) a first user input, via the one or more input units 1204, associated with one or more edges of the first window. In response to detecting the first user input, and in accordance with a determination (e.g., with the input type determining unit 1214) that the first user input corresponds to a first input type, the processing unit 1208 is further configured to resize (e.g., with the display control unit 1210) one or more dimensions of the first window that correspond to the one or more edges of the first window based on a movement associated with the first user input. In response to detecting the first user input, and in accordance with a determination (e.g., with the input type determining unit 1214) that the first user input corresponds to a second input type, the processing unit 1208 is further configured to move (e.g., with the display control unit 1210) the one or more edges of the first window to one or more corresponding edges of the display area while maintaining respective one or more opposite edges of the first window.

**[00391]** In some embodiments, the first input type corresponds to an input that includes a selection followed by movement.

**[00392]** In some embodiments, the second input type corresponds to a stationary input.

**[00393]** In some embodiments, moving the one or more edges of the first window to one or more corresponding edges of the display area includes moving a single edge of the first window to a corresponding edge of the display area in accordance with a determination that the first user input corresponds to the single edge of the first window.

**[00394]** In some embodiments, after moving the single edge of the first window to the edge of the display area that corresponds to the single edge of the first window, the processing unit 1208 is further configured to detect (e.g., with the input detecting unit 1212) a second user input, via the one or more input unit 1204, associated with the single edge of the first window. In response to detecting the second user input, and in accordance with a determination (e.g., with the input type determining unit 1214) that the second user input corresponds to the second input, the processing unit 1208 is further configured to move (e.g., with the display control unit 1210) the single edge of the first window to a position at which the single edge was located on the display unit 1202 prior detecting to the first user input.

**[00395]** In some embodiments, prior to detecting the first user input, a second window is displayed within the display area between the first window and the edge of the display area that corresponds to the single edge of the first window, and, in accordance with a determination (e.g., with the input type determining unit 1214) that first user input corresponds to the single edge of the first window and the second input type, the movement of the single edge of the first window to the corresponding edge of the display area is bound by an edge of the second window that is parallel to the single edge of the first window.

**[00396]** In some embodiments, moving the one or more edges of the first window to one or more corresponding edges of the display area includes moving two edges of the first window that are adjacent to a corner of the first window to two corresponding edges of the display area in accordance with a determination that the first user input corresponds to the corner of the first window.

**[00397]** In some embodiments, after moving two edges of the first window that are adjacent to the corner of the first window to the two corresponding edges of the display area, the processing unit 1208 is further configured to detect (e.g., with the input detecting unit 1212) a second user input, via the one or more input unit 1204, associated with at least one edge of the first window. In response to detecting the second user input, and in accordance

with a determination that the second user input corresponds to a single edge of the first window and in accordance with a determination (e.g., with the input type determining unit 1214) that the second user input corresponds to the second input, the processing unit 1208 is further configured to move (e.g., with the display control unit 1210) the single edge of the first window to a position at which the single edge was located on the display unit 1202 prior detecting to the first user input. In response to detecting the second user input, and in accordance with a determination that the second user input corresponds to a corner of the first window and in accordance with a determination (e.g., with the input type determining unit 1214) that the second user input corresponds to the second input type, the processing unit 1208 is further configured to move (e.g., with the display control unit 1210) the two edges of the first window that correspond to the corner of the first window to position at which the two edges were located on the display unit 1202 prior detecting to the first user input.

**[00398]** In some embodiments, prior to detecting the first user input, a second window is displayed within the display area between the first window and at least one of the two corresponding edges of the display area, and, in accordance with a determination that first user input corresponds to the corner of the first window and in accordance with a determination (e.g., with the input type determining unit 1214) that second user input corresponds to the second input type, the movement of at least one of the two edges of the first window that are adjacent to the corner of the first window to two corresponding edges of the display area is bound by at least one edge of the second window that is parallel to the two edges of the first window.

**[00399]** In some embodiments, resizing the one or more dimensions of the first window that correspond to the one or more edges of the first window includes: in accordance with a determination (e.g., with the expansion determining unit 1216) that the first user input satisfies one or more expansion criteria, resizing one dimension of the first window to two parallel edges of the display area; and, in accordance with a determination (e.g., with the expansion determining unit 1216) that the first user input does not satisfy the one or more expansion criteria, resizing the one dimension of the first window to one edge of the display area.

**[00400]** In some embodiments, resizing the one or more dimensions of the first window that correspond to the one or more edges of the first window includes: in accordance with a

determination (e.g., with the expansion determining unit 1216) that the first user input satisfies one or more expansion criteria, resizing a first dimension of the first window to a first set of two parallel edges of the display area and resizing a second dimension of the first window to a second set of parallel edges of the display area, where the first and second sets of parallel edges of the display area are distinct; and, in accordance with a determination (e.g., with the expansion determining unit 1216) that the first user input does not satisfy the one or more expansion criteria, resizing the first dimension of the first window to a first edge of the display area and the second dimension of the first window to a second edge of the display area.

**[00401]** In some embodiments, a magnitude of the movement vector associated with the first user input is less than a distance between the one or more edges of the first window and one or more corresponding edges of the display area, and the one or more edges of the first window are not co-located with the one or more corresponding edges of the display area after resizing the one or more dimensions of the first window that correspond to the one or more edges of the first window based on the movement vector associated with the first user input.

**[00402]** In some embodiments, in response to detecting the first user input, and in accordance with a determination (e.g., with the input type determining unit 1214) that the first user input corresponds to a third input type, the processing unit 1208 is further configured to move (e.g., with the display control unit 1210) one or more edges of the first window to one or more corresponding edges of the display area.

**[00403]** In accordance with some embodiments, Figure 13 shows a functional block diagram of an electronic device 1300 configured in accordance with the principles of the various described embodiments. The functional blocks of the device are, optionally, implemented by hardware, software, firmware, or a combination thereof to carry out the principles of the various described embodiments. It is understood by persons of skill in the art that the functional blocks described in Figure 13 are, optionally, combined or separated into sub-blocks to implement the principles of the various described embodiments. Therefore, the description herein optionally supports any possible combination or separation or further definition of the functional blocks described herein.



**[00404]** As shown in Figure 13, an electronic device 1300 includes a display unit 1302 configured to display a user interface, one or more input units 1304 configured to receive user inputs, and a processing unit 1308 coupled to the display unit 1302 and the one or more input units 1304. In some embodiments, the processing unit 1308 includes: a display control unit 1310, an input detecting unit 1312, a determining unit 1314, and a tab management unit 1316.

**[00405]** The processing unit 1308 is configured to: enable display of (e.g., with the display control unit 1310), on the display unit 1302, a first window associated with a first application within a display area; and detect (e.g., with the input detecting unit 1312) a first user input, via the one or more input unit 1304, that corresponds to a request to add a second window associated with the first application. In response to detecting the first user input, and in accordance with a determination (e.g., with the determining unit 1314) that the first window is displayed within the display area in full screen mode, the processing unit 1308 is further configured to add (e.g., with the tab management unit 1316) the second window as a new tab within a tab bar associated with the first window. In response to detecting the first user input, and in accordance with a determination (e.g., with the determining unit 1314) that the first window is displayed within the display area in windowed mode, the processing unit 1308 is further configured to enable display of (e.g., with the display control unit 1310) the second window separate from the first window within the display area.

**[00406]** In some embodiments, the first user input corresponds to selection of an affordance within the first window that causes an instruction to be sent to the first application to generate a new window associated with the first application.

**[00407]** In some embodiments, the first user input corresponds to a combination of one or more keystrokes that causes an instruction to be sent to the first application to generate a new window associated with the first application.

**[00408]** In some embodiments, adding the second window as the new tab within the tab bar associated with the first window includes displaying the second window as a tab within the second window as the new tab within the tab bar associated with the first window after the second application generates the second window.

**[00409]** In some embodiments, adding the second window as a new tab within a tab bar associated with the first window includes: determining whether a global tabbed window functionality is enabled; and, in accordance with the determination that the first window is

displayed within the display area in full screen mode and in accordance with a determination that the global tabbed window setting is enabled, adding the second window as a new tab within a tab bar associated with the first window.

**[00410]** In some embodiments, the first application is not included on an opt-out list for the global tabbed window functionality.

**[00411]** In some embodiments, after displaying the second window separate from the first window within the display area, the processing unit 1308 is further configured to detect (e.g., with the input detecting unit 1312) a second user input, via the one or more input units 1304, to merge the first and second windows into a single tabbed window. In response to detecting the second user input, the processing unit 1308 is further configured to replace display of (e.g., with the display control unit 1310) the separate first and second windows with a merged window that includes a tab bar with a first tab associated with the first window and a second tab associated with the second window.

**[00412]** In some embodiments, the tab bar is displayed in a chrome region of the merged window, and the tab bar is generated and controlled independent of the first application.

**[00413]** In some embodiments, after displaying the merged window, the processing unit 1308 is further configured to detect (e.g., with the input detecting unit 1312) a third user input, via the one or more input units 1304, to close the merged window, and, in response to detecting the third user input, the processing unit 1308 is further configured to send (e.g., with the tab management unit 1316) window close instructions to the first application to close the first and second windows.

**[00414]** In some embodiments, after displaying the merged window, the processing unit 1308 is further configured to detect (e.g., with the input detecting unit 1312) a third user input, via the one or more input units 1304, dragging a third window separate from the merged window into the tab bar of the merged window, where the third window is associated with a second application, and, in response to the third user input, the processing unit 1308 is further configured to add (e.g., with the tab management unit 1316) a new tab associated with the third window to the tab bar of the merged window.

**[00415]** In some embodiments, after displaying the merged window, the processing unit 1308 is further configured to detect (e.g., with the input detecting unit 1312) a third user input, via the one or more input units 1304, dragging the merged window into a third window separate from the merged window, where the third window is associated with a second application, and, in response to the third user input, the processing unit 1308 is further configured to add (e.g., with the tab management unit 1316) a new tab associated with the third window to the tab bar of the merged window.

**[00416]** In some embodiments, after adding the new tab associated with the third window to the tab bar of the merged window, the processing unit 1308 is further configured to detect (e.g., with the input detecting unit 1312) a fourth user input, via the one or more input units 1304, close the merged window, and, in response to detecting the fourth user input, the processing unit 1308 is further configured to send (e.g., with the tab management unit 1316) a first window close instruction to the first application to close the first and second windows and a second window close instruction to the second application to close the third window.

**[00417]** In some embodiments, after detecting the first user input, the processing unit 1308 is further configured to detect (e.g., with the input detecting unit 1312) a subsequent user input, via the one or more input units 1304, to add a third window associated with a second application. In response to detecting the subsequent user input, and in accordance with a determination (e.g., with the determining unit 1314) that the first window is displayed within the display area in full screen mode, the processing unit 1308 is further configured to add (e.g., with the tab management unit 1316) the third window as a new tab in a tab bar associated with the first window. In response to detecting the subsequent user input, and in accordance with a determination (e.g., with the determining unit 1314) that the first window is displayed within the display area in windowed mode, the processing unit 1308 is further configured to enable display of (e.g., with the display control unit 1310) the third window as a separate window within the display area.

**[00418]** The operations in the information processing methods described above are, optionally implemented by running one or more functional modules in information processing apparatus such as general purpose processors (e.g., as described above with respect to Figures 1A and 3) or application specific chips.

**[00419]** The operations described above with reference to Figures 8A-8E, 9A-9D, and 10A-10C are, optionally, implemented by components depicted in Figures 1A-1B or Figures 11-13. For example, detection operation 804, detection operation 904, and detection operation 1004 are, optionally, implemented by event sorter 170, event recognizer 180, and event handler 190. Event monitor 171 in event sorter 170 detects a contact on touch-sensitive display 112, and event dispatcher module 174 delivers the event information to application 136-1. A respective event recognizer 180 of application 136-1 compares the event information to respective event definitions 186, and determines whether a first contact at a first location on the touch-sensitive surface (or whether rotation of the device) corresponds to a predefined event or sub-event, such as selection of an object on a user interface, or rotation of the device from one orientation to another. When a respective predefined event or sub-event is detected, event recognizer 180 activates an event handler 190 associated with the detection of the event or sub-event. Event handler 190 optionally uses or calls data updater 176 or object updater 177 to update the application internal state 192. In some embodiments, event handler 190 accesses a respective GUI updater 178 to update what is displayed by the application. Similarly, it would be clear to a person having ordinary skill in the art how other processes can be implemented based on the components depicted in Figures 1A-1B.

**[00420]** The foregoing description, for purpose of explanation, has been described with reference to specific embodiments. However, the illustrative discussions above are not intended to be exhaustive or to limit the invention to the precise forms disclosed. Many modifications and variations are possible in view of the above teachings. The embodiments were chosen and described in order to best explain the principles of the invention and its practical applications, to thereby enable others skilled in the art to best use the invention and various described embodiments with various modifications as are suited to the particular use contemplated.

What is claimed is:

1. A method comprising:
  - at a device with one or more processors, non-transitory memory, a display, and an input device:
    - displaying, on the display, a first window and a second window within a display area, the first window having a first edge parallel to a second edge of the second window;
    - detecting a first user input, via the input device, moving the first edge of the first window toward the second edge of the second window; and
    - in response to detecting the first user input:
      - in accordance with a determination that the first user input satisfies one or more pairing criteria, pairing the first edge of the first window to the second edge of the second window such that the first window stops moving in response to the first user input before it overlaps the second window, wherein the one or more pairing criteria include a first pairing criterion that is met when the first user input corresponds to movement of the first edge toward the second edge that deviates from a predefined axis by less than an angular threshold value; and
      - in accordance with a determination that the first user input does not satisfy the one or more pairing criteria, continuing the movement of the first window based on the first user input so that the first window at least partially overlaps the second window.
2. The method of claim 1, wherein the first user input corresponds to moving the first window within the display area by dragging the first window toward the second window.
3. The method of claim 1, wherein the first user input corresponds to resizing the first window within the display area by dragging the first edge of the first window toward the second window.
4. The method of any of claims 1-3, wherein a second pairing criterion of the one or more pairing criteria includes a velocity threshold value, and satisfying the second pairing criterion includes determining that a velocity associated with the first user input breaches the velocity threshold value.

5. The method of any of claims 1-4, wherein a third pairing criterion of the one or more pairing criteria includes a distance threshold value, and satisfying the third pairing criterion includes determining that the input corresponds to movement of the first edge of the window in a respective direction to the edge of the second window without corresponding to more than a threshold amount of movement in the respective direction.

6. The method of any of claims 1-5, further comprising:  
in response to detecting the first user input, and in accordance with a determination that the first user input satisfies one or more pairing criteria and that the first window is overlapping the second window, continuing the movement of the first window based on the first user input and displaying the first window at least partially overlapping the second window.

7. The method of any of claims 1-6, further comprising:  
in response to detecting the first user input, and in accordance with a determination that the first user input satisfies one or more pairing criteria and that the second edge of the second window is occluded within the display area, continuing the movement of the first window based on the first user input and displaying the first window at least partially overlaps the second window.

8. The method of any of claims 1-7, further comprising:  
while the first edge of the first window is paired with the second edge of the second window, detecting a second user input, via the input device, moving the first window away from the second window; and  
in response to the second user input, unpairing the first edge of the first window from the second edge of the second window and moving the first window according to a movement vector associated with the second user input.

9. The method of any of claims 1-7, further comprising:  
while the first edge of the first window is paired with the second edge of the second window, detecting a second component of the first user input moving the first window away from the second window; and  
in response to the second component of the first user input and in accordance with a determination that a magnitude of the second component breaches a distance threshold,

unpairing the first edge of the first window from the second edge of the second window and moving the first window according to a movement vector associated with the second component of the first user input.

10. The method of any of claims 1-7, further comprising:

while the first edge of the first window is paired with the second edge of the second window, detecting a second user input, via the input device, moving the first window toward the second edge of the second window; and

in response to detecting the second user input:

in accordance with a determination that the second user input satisfies one or more separation criteria, unpairing the first edge of the first window from the second edge of the second window and moving the first window over the second window according to a movement vector associated with the second user input; and

in accordance with a determination that the second user input does not satisfy the one or more separation criteria, maintaining the pairing between the first edge of the first window and the second edge of the second window and foregoing moving the first window over the second window.

11. The method of claim 10, wherein moving the first window over the second window according to the movement vector associated with the second user input includes:

in accordance with a determination that the second user input corresponds to moving a focus selector over the second window, displaying an animation such that moving the first window over the second window is discontinuous; and

in accordance with a determination that the second user input does not correspond to moving the focus selector over the second window, foregoing displaying the animation such that moving the first window over the second window is continuous.

12. The method of any of claims 1-7, further comprising:

while the first edge of the first window is paired with the second edge of the second window, detecting a second user input, via the input device, that corresponds to movement of the first edge relative to the second edge; and

in response to detecting the second user input:

in accordance with a determination that the second user input corresponds to movement of the first window such that the first edge of the first window moves over the second edge, delaying movement of the first window until the second user input has reached a movement threshold; and

in accordance with a determination that the second user input corresponds to movement of the first window such that the first edge of the first window moves away from the second edge, starting to move the first window before the second user input has reached the movement threshold.

13. The method of any of claims 1-7, further comprising:

while the first edge of the first window is paired with the second edge of the second window, detecting a second user input, via the input device, moving the first window along the second edge of the second window; and

in response to detecting the second user input:

in accordance with a determination that the second user input satisfies one or more separation criteria, unpairing the first edge of the first window from the second edge of the second window and moving the first window according to a movement vector associated with the second user input; and

in accordance with a determination that the second user input does not satisfy any of the one or more separation criteria, maintaining the pairing between the first edge of the first window and the second edge of the second window and moving the first window parallel to the second edge of the second window according to the second user input.

14. The method of claim 13, wherein the parallel movement of the first window is constrained by a third edge of the second window, and wherein the third edge of the second window is perpendicular to the second edge of the second window.

15. The method of any of claims 1-7, further comprising:

while the first edge of the first window is paired with the second edge of the second window, detecting a second user input, via the input device, moving the second window along the first edge of the first window; and

in response to detecting the second user input:



in accordance with a determination that the second user input satisfies one or more separation criteria, unpairing the second edge of the second window from the first edge of the first window and moving the second window according to second user input; and

in accordance with a determination that the second user input does not satisfy any of the one or more of the separation criteria, maintaining the pairing between the first edge of the first window and the second edge of the second window and moving the second window parallel to the first edge of the first window according to a movement vector associated with the second user input.

16. The method of any of claims 1-7, further comprising:

while the first edge of the first window is paired with the second edge of the second window, detecting a second user input, via the input device, dragging a respective edge of the first window along the second edge of the second window, wherein the respective edge of the first window is perpendicular to the second edge of the second window; and

in response to detecting the second user input, resizing a dimension of the first window associated with the respective edge according to the second user input.

17. The method of claim 16, wherein the resized dimension of the first window is constrained by a third edge of the second window, and wherein the third edge of the second window is perpendicular to the second edge of the second window.

18. An electronic device comprising:

a display;

an input device;

one or more processors;

non-transitory memory; and

one or more programs, wherein the one or more programs are stored in the memory and configured to be executed by the one or more processors, the one or more programs including instructions for:

displaying, on the display, a first window and a second window within a display area, the first window having a first edge parallel to a second edge of the second window;

detecting a first user input, via the input device, moving the first edge of the first window toward the second edge of the second window; and

in response to detecting the first user input:

in accordance with a determination that the first user input satisfies one or more pairing criteria, pairing the first edge of the first window to the second edge of the second window such that the first window stops moving in response to the first user input before it overlaps the second window, wherein the one or more pairing criteria include a first pairing criterion that is met when the first user input corresponds to movement of the first edge toward the second edge that deviates from a predefined axis by less than an angular threshold value; and

in accordance with a determination that the first user input does not satisfy the one or more pairing criteria, continuing the movement of the first window based on the first user input so that the first window at least partially overlaps the second window.

19. A non-transitory computer readable storage medium storing one or more programs, the one or more programs comprising instructions, which, when executed by an electronic device with a display, and an input device, cause the electronic device to:

display, on the display, a first window and a second window within a display area, the first window having a first edge parallel to a second edge of the second window;

detect a first user input, via the input device, moving the first edge of the first window toward the second edge of the second window; and

in response to detecting the first user input:

in accordance with a determination that the first user input satisfies one or more pairing criteria, pair the first edge of the first window to the second edge of the second window such that the first window stops moving in response to the first user input before it overlaps the second window, wherein the one or more pairing criteria include a first pairing criterion that is met when the first user input corresponds to movement of the first edge toward the second edge that deviates from a predefined axis by less than an angular threshold value; and

in accordance with a determination that the first user input does not satisfy the one or more pairing criteria, continue the movement of the first window based on the first user input so that the first window at least partially overlaps the second window.

20. An electronic device comprising:  
a display;  
an input device;  
means for displaying, on the display, a first window and a second window within a display area, the first window having a first edge parallel to a second edge of the second window;  
means for detecting a first user input, via the input device, moving the first edge of the first window toward the second edge of the second window;  
means, responsive to detecting the first user input, for pairing the first edge of the first window to the second edge of the second window such that the first window stops moving in response to the first user input before it overlaps the second window in accordance with a determination that the first user input satisfies one or more pairing criteria, wherein the one or more pairing criteria include a first pairing criterion that is met when the first user input corresponds to movement of the first edge toward the second edge that deviates from a predefined axis by less than an angular threshold value; and  
means, responsive to detecting the first user input, for continuing the movement of the first window based on the first user input so that the first window at least partially overlaps the second window in accordance with a determination that the first user input does not satisfy the one or more pairing criteria.
21. An electronic device comprising:  
a display;  
an input device;  
one or more processors;  
non-transitory memory; and  
one or more programs, wherein the one or more programs are stored in the memory and configured to be executed by the one or more processors, the one or more programs including instructions for performing or causing performance of any of the methods of claims 1-17.
22. A non-transitory computer readable storage medium storing one or more programs, the one or more programs comprising instructions, which, when executed by an electronic

device with a display, and an input device, cause the electronic device to perform or cause performance of any of the methods of claims 1-17.

23. An electronic device comprising:

a display;

an input device; and

means for performing or causing performance of any of the methods of claims 1-17.

24. A graphical user interface on an electronic device with a display, an input device, a non-transitory memory, and one or more processors to execute one or more programs stored in the non-transitory memory, the graphical user interface comprising user interfaces displayed in accordance with any of the methods of claims 1-17.

25. An information processing apparatus for use in an electronic device with a display and an input device, comprising:

means for performing or causing performance of any of the methods of claims 1-17.

26. An electronic device comprising:

a display unit configured to display a user interface;

one or more input units configured to receive inputs; and

a processing unit coupled with the display unit and the one or more input units, the processing unit configured to:

enable display of, on the display unit, a first window and a second window within a display area, the first window having a first edge parallel to a second edge of the second window;

detect a first user input, via the one or more input units, moving the first edge of the first window toward the second edge of the second window; and

in response to detecting the first user input:

in accordance with a determination that the first user input satisfies one or more pairing criteria, pair the first edge of the first window to the second edge of the second window such that the first window stops moving in response to the first user input before it overlaps the second window, wherein the one or more pairing criteria include a first pairing criterion that is met when the first user input corresponds to movement of the first edge toward

the second edge that deviates from a predefined axis by less than an angular threshold value;  
and

in accordance with a determination that the first user input does not satisfy the one or more pairing criteria, continue the movement of the first window based on the first user input so that the first window at least partially overlaps the second window.

27. The electronic device of claim 26, wherein the first user input corresponds to moving the first window within the display area by dragging the first window toward the second window.

28. The electronic device of claim 26, wherein the first user input corresponds to resizing the first window within the display area by dragging the first edge of the first window toward the second window.

29. The electronic device of any of claims 26-28, wherein a second pairing criterion of the one or more pairing criteria includes a velocity threshold value, and satisfying the second pairing criterion includes determining that a velocity associated with the first user input breaches the velocity threshold value.

30. The electronic device of any of claims 26-29, wherein a third pairing criterion of the one or more pairing criteria includes a distance threshold value, and satisfying the third pairing criterion includes determining that the input corresponds to movement of the first edge of the window in a respective direction to the edge of the second window without corresponding to more than a threshold amount of movement in the respective direction.

31. The electronic device of any of claims 26-30, wherein the processing unit is further configured to:

in response to detecting the first user input, and in accordance with a determination that the first user input satisfies one or more pairing criteria and that the first window is overlapping the second window, continue the movement of the first window based on the first user input and displaying the first window at least partially overlapping the second window.

32. The electronic device of any of claims 26-31, wherein the processing unit is further configured to:

in response to detecting the first user input, and in accordance with a determination that the first user input satisfies one or more pairing criteria and that the second edge of the second window is occluded within the display area, continue the movement of the first window based on the first user input and displaying the first window at least partially overlaps the second window.

33. The electronic device of any of claims 26-32, wherein the processing unit is further configured to:

while the first edge of the first window is paired with the second edge of the second window, detect a second user input, via the one or more input units, moving the first window away from the second window; and

in response to the second user input, unpair the first edge of the first window from the second edge of the second window and moving the first window according to a movement vector associated with the second user input.

34. The electronic device of any of claims 26-32, wherein the processing unit is further configured to:

while the first edge of the first window is paired with the second edge of the second window, detect a second component of the first user input moving the first window away from the second window; and

in response to the second component of the first user input and in accordance with a determination that a magnitude of the second component breaches a distance threshold, unpair the first edge of the first window from the second edge of the second window and moving the first window according to a movement vector associated with the second component of the first user input.

35. The electronic device of any of claims 26-32, wherein the processing unit is further configured to:

while the first edge of the first window is paired with the second edge of the second window, detect a second user input, via the one or more input units, moving the first window toward the second edge of the second window; and

in response to detecting the second user input:

in accordance with a determination that the second user input satisfies one or more separation criteria, unpair the first edge of the first window from the second edge of the second window and moving the first window over the second window according to a movement vector associated with the second user input; and

in accordance with a determination that the second user input does not satisfy the one or more separation criteria, maintain the pairing between the first edge of the first window and the second edge of the second window and foregoing moving the first window over the second window.

36. The electronic device of claim 35, wherein moving the first window over the second window according to the movement vector associated with the second user input includes:

in accordance with a determination that the second user input corresponds to moving a focus selector over the second window, displaying an animation such that moving the first window over the second window is discontinuous; and

in accordance with a determination that the second user input does not correspond to moving the focus selector over the second window, foregoing displaying the animation such that moving the first window over the second window is continuous.

37. The electronic device of any of claims 26-32, wherein the processing unit is further configured to:

while the first edge of the first window is paired with the second edge of the second window, detect a second user input, via the one or more input units, that corresponds to movement of the first edge relative to the second edge; and

in response to detecting the second user input:

in accordance with a determination that the second user input corresponds to movement of the first window such that the first edge of the first window moves over the second edge, delay movement of the first window until the second user input has reached a movement threshold; and

in accordance with a determination that the second user input corresponds to movement of the first window such that the first edge of the first window moves away from the second edge, start to move the first window before the second user input has reached the movement threshold.

38. The electronic device of any of claims 26-32, wherein the processing unit is further configured to:

while the first edge of the first window is paired with the second edge of the second window, detect a second user input, via the one or more input units, moving the first window along the second edge of the second window; and

in response to detecting the second user input:

in accordance with a determination that the second user input satisfies one or more separation criteria, unpair the first edge of the first window from the second edge of the second window and moving the first window according to a movement vector associated with the second user input; and

in accordance with a determination that the second user input does not satisfy any of the one or more separation criteria, maintain the pairing between the first edge of the first window and the second edge of the second window and moving the first window parallel to the second edge of the second window according to the second user input.

39. The electronic device of claim 38, wherein the parallel movement of the first window is constrained by a third edge of the second window, and wherein the third edge of the second window is perpendicular to the second edge of the second window.

40. The electronic device of any of claims 26-32, wherein the processing unit is further configured to:

while the first edge of the first window is paired with the second edge of the second window, detect a second user input, via the one or more input units, moving the second window along the first edge of the first window; and

in response to detecting the second user input:

in accordance with a determination that the second user input satisfies one or more separation criteria, unpair the second edge of the second window from the first edge of the first window and moving the second window according to second user input; and

in accordance with a determination that the second user input does not satisfy any of the one or more of the separation criteria, maintain the pairing between the first edge of the first window and the second edge of the second window and moving the second window parallel to the first edge of the first window.



41. The electronic device of any of claims 26-32, wherein the processing unit is further configured to:

while the first edge of the first window is paired with the second edge of the second window, detect a second user input, via the one or more input units, dragging a respective edge of the first window along the second edge of the second window, wherein the respective edge of the first window is perpendicular to the second edge of the second window; and

in response to detecting the second user input, resize a dimension of the first window associated with the respective edge according to the second user input.

42. The electronic device of claim 41, wherein the resized dimension of the first window is constrained by a third edge of the second window, and wherein the third edge of the second window is perpendicular to the second edge of the second window.

43. A method comprising:

at a device with one or more processors, non-transitory memory, a display, and an input device:

displaying, on the display, a first window in a display area;

detecting a first user input, via the input device, associated with one or more edges of the first window;

in response to detecting the first user input:

in accordance with a determination that the first user input corresponds to a first input type, resizing one or more dimensions of the first window that correspond to the one or more edges of the first window based on a movement vector associated with the first user input; and

in accordance with a determination that the first user input corresponds to a second input type, moving the one or more edges of the first window to one or more corresponding edges of the display area while maintaining respective one or more opposite edges of the first window.

44. The method of claim 43, wherein the first input type corresponds to an input that includes a selection followed by movement.

45. The method of any of claims 43-44, wherein the second input type corresponds to a stationary input.

46. The method of any of claims 43-45, wherein moving the one or more edges of the first window to one or more corresponding edges of the display area includes moving a single edge of the first window to a corresponding edge of the display area in accordance with a determination that the first user input corresponds to the single edge of the first window.

47. The method of claim 46, further comprising:

after moving the single edge of the first window to the edge of the display area that corresponds to the single edge of the first window, detecting a second user input, via the input device, associated with the single edge of the first window; and

in response to detecting the second user input, and in accordance with a determination that the second user input corresponds to the second input type, moving the single edge of the first window to a position at which the single edge was located on the display prior detecting to the first user input.

48. The method of claim 46, wherein, prior to detecting the first user input, a second window is displayed within the display area between the first window and the edge of the display area that corresponds to the single edge of the first window, and

wherein, in accordance with a determination that first user input corresponds to the single edge of the first window and the second input type, the movement of the single edge of the first window to the corresponding edge of the display area is bound by an edge of the second window that is parallel to the single edge of the first window.

49. The method of any of claims 43-45, wherein moving the one or more edges of the first window to one or more corresponding edges of the display area includes moving two edges of the first window that are adjacent to a corner of the first window to two corresponding edges of the display area in accordance with a determination that the first user input corresponds to the corner of the first window.

50. The method of claim 49, further comprising:

after moving two edges of the first window that are adjacent to the corner of the first window to the two corresponding edges of the display area, detecting a second user input, via the input device, associated with at least one edge of the first window; and

in response to detecting the second user input:

in accordance with a determination that the second user input corresponds to a single edge of the first window and in accordance with a determination that the second user input corresponds to the second input type, moving the single edge of the first window to a position at which the single edge was located on the display prior detecting to the first user input; and

in accordance with a determination that the second user input corresponds to a corner of the first window and in accordance with a determination that the second user input corresponds to the second input type, moving the two edges of the first window that correspond to the corner of the first window to position at which the two edges were located on the display prior detecting to the first user input.

51. The method of claim 49, wherein, prior to detecting the first user input, a second window is displayed within the display area between the first window and at least one of the two corresponding edges of the display area, and

wherein, in accordance with a determination that first user input corresponds to the corner of the first window and in accordance with a determination that second user input corresponds to the second input type, the movement of at least one of the two edges of the first window that are adjacent to the corner of the first window to two corresponding edges of the display area is bound by at least one edge of the second window that is parallel to the two edges of the first window.

52. The method of any of claims 43-45, wherein resizing the one or more dimensions of the first window that correspond to the one or more edges of the first window includes:

in accordance with a determination that the first user input satisfies one or more expansion criteria, resizing one dimension of the first window to two parallel edges of the display area; and

in accordance with a determination that the first user input does not satisfy the one or more expansion criteria, resizing the one dimension of the first window to one edge of the display area.

53. The method of any of claims 43-45, wherein resizing the one or more dimensions of the first window that correspond to the one or more edges of the first window includes:

in accordance with a determination that the first user input satisfies one or more expansion criteria, resizing a first dimension of the first window to a first set of two parallel edges of the display area and resizing a second dimension of the first window to a second set of parallel edges of the display area, wherein the first and second sets of parallel edges of the display area are distinct; and

in accordance with a determination that the first user input does not satisfy the one or more expansion criteria, resizing the first dimension of the first window to a first edge of the display area and the second dimension of the first window to a second edge of the display area.

54. The method of any of claims 43-45, wherein a magnitude of the movement vector associated with the first user input is less than a distance between the one or more edges of the first window and one or more corresponding edges of the display area, and

wherein the one or more edges of the first window are not co-located with the one or more corresponding edges of the display area after resizing the one or more dimensions of the first window that correspond to the one or more edges of the first window based on the movement vector associated with the first user input.

55. The method of any of claims 43-45, further comprising:

in response to detecting the first user input:

in accordance with a determination that the first user input corresponds to a third input type, moving one or more edges of the first window to one or more corresponding edges of the display area.

56. An electronic device comprising:

a display;

an input device;

one or more processors;

non-transitory memory; and

one or more programs, wherein the one or more programs are stored in the memory and configured to be executed by the one or more processors, the one or more programs including instructions for:

displaying, on the display, a first window in a display area;

detecting a first user input, via the input device, associated with one or more edges of the first window;

in response to detecting the first user input:

in accordance with a determination that the first user input corresponds to a first input type, resizing one or more dimensions of the first window that correspond to the one or more edges of the first window based on a movement vector associated with the first user input; and

in accordance with a determination that the first user input corresponds to a second input type, moving the one or more edges of the first window to one or more corresponding edges of the display area while maintaining respective one or more opposite edges of the first window.

57. A non-transitory computer readable storage medium storing one or more programs, the one or more programs comprising instructions, which, when executed by an electronic device with a display, and an input device, cause the electronic device to:

display, on the display, a first window in a display area;

detect a first user input, via the input device, associated with one or more edges of the first window;

in response to detecting the first user input:

in accordance with a determination that the first user input corresponds to a first input type, resize one or more dimensions of the first window that correspond to the one or more edges of the first window based on a movement vector associated with the first user input; and

in accordance with a determination that the first user input corresponds to a second input type, move the one or more edges of the first window to one or more corresponding edges of the display area while maintaining respective one or more opposite edges of the first window.

58. An electronic device comprising:

a display;

an input device;

means for displaying, on the display, a first window in a display area;

means for detecting a first user input, via the input device, associated with one or more edges of the first window;

means, responsive to detecting the first user input, for resizing one or more dimensions of the first window that correspond to the one or more edges of the first window based on a movement vector associated with the first user input in accordance with a determination that the first user input corresponds to a first input type; and

means, responsive to detecting the first user input, for moving the one or more edges of the first window to one or more corresponding edges of the display area while maintaining respective one or more opposite edges of the first window in accordance with a determination that the first user input corresponds to a second input type.

59. An electronic device comprising:

a display;

an input device;

one or more processors;

non-transitory memory; and

one or more programs, wherein the one or more programs are stored in the memory and configured to be executed by the one or more processors, the one or more programs including instructions for performing or causing performance of any of the methods of claims 43-55.

60. A non-transitory computer readable storage medium storing one or more programs, the one or more programs comprising instructions, which, when executed by an electronic device with a display, and an input device, cause the electronic device to perform or cause performance of any of the methods of claims 43-55.

61. An electronic device comprising:

a display;

an input device; and

means for performing or causing performance of any of the methods of claims 43-55.

62. A graphical user interface on an electronic device with a display, an input device, a non-transitory memory, and one or more processors to execute one or more programs stored

in the non-transitory memory, the graphical user interface comprising user interfaces displayed in accordance with any of the methods of claims 43-55.

63. An information processing apparatus for use in an electronic device with a display and an input device, comprising:

means for performing or causing performance of any of the methods of claims 43-55.

64. An electronic device comprising:

a display unit configured to display a user interface;

one or more input units configured to receive inputs;

one or more sensor units configured to determine the intensity of contacts received by the one or more input units; and

a processing unit coupled with the display unit, the one or more input units, and the one or more sensor units, the processing unit configured to:

enable display of, on the display unit, a first window in a display area;

detect a first user input, via the one or more input units, associated with one or more edges of the first window;

in response to detecting the first user input:

in accordance with a determination that the first user input corresponds to a first input type, resize one or more dimensions of the first window that correspond to the one or more edges of the first window based on a movement vector associated with the first user input; and

in accordance with a determination that the first user input corresponds to a second input type, move the one or more edges of the first window to one or more corresponding edges of the display area while maintaining respective one or more opposite edges of the first window.

65. The electronic device of claim 64, wherein the first input type corresponds to an input that includes a selection followed by movement.

66. The electronic device of any of claims 64-65, wherein the second input type corresponds to a stationary input.

67. The electronic device of any of claims 64-66, wherein moving the one or more edges of the first window to one or more corresponding edges of the display area includes moving a single edge of the first window to a corresponding edge of the display area in accordance with a determination that the first user input corresponds to the single edge of the first window.

68. The electronic device of claim 67, wherein the processing unit is further configured to:

after moving the single edge of the first window to the edge of the display area that corresponds to the single edge of the first window, detect a second user input, via the one or more input units, associated with the single edge of the first window; and

in response to detecting the second user input, and in accordance with a determination that the second user input corresponds to the second input type, move the single edge of the first window to a position at which the single edge was located on the display prior detecting to the first user input.

69. The electronic device of claim 67, wherein, prior to detecting the first user input, a second window is displayed within the display area between the first window and the edge of the display area that corresponds to the single edge of the first window, and

wherein, in accordance with a determination that first user input corresponds to the single edge of the first window and the second input type, the movement of the single edge of the first window to the corresponding edge of the display area is bound by an edge of the second window that is parallel to the single edge of the first window.

70. The electronic device of any of claims 64-66, wherein moving the one or more edges of the first window to one or more corresponding edges of the display area includes moving two edges of the first window that are adjacent to a corner of the first window to two corresponding edges of the display area in accordance with a determination that the first user input corresponds to the corner of the first window.

71. The electronic device of claim 70, wherein the processing unit is further configured to:



after moving two edges of the first window that are adjacent to the corner of the first window to the two corresponding edges of the display area, detect a second user input, via the one or more input units, associated with at least one edge of the first window; and

in response to detecting the second user input:

in accordance with a determination that the second user input corresponds to a single edge of the first window and in accordance with a determination that the second user input corresponds to the second input type, move the single edge of the first window to a position at which the single edge was located on the display prior detecting to the first user input; and

in accordance with a determination that the second user input corresponds to a corner of the first window and in accordance with a determination that the second user input corresponds to the second input type, move the two edges of the first window that correspond to the corner of the first window to position at which the two edges were located on the display prior detecting to the first user input.

72. The electronic device of claim 70, wherein, prior to detecting the first user input, a second window is displayed within the display area between the first window and at least one of the two corresponding edges of the display area, and

wherein, in accordance with a determination that first user input corresponds to the corner of the first window and in accordance with a determination that second user input corresponds to the second input type, the movement of at least one of the two edges of the first window that are adjacent to the corner of the first window to two corresponding edges of the display area is bound by at least one edge of the second window that is parallel to the two edges of the first window.

73. The electronic device of any of claims 64-66, wherein resizing the one or more dimensions of the first window that correspond to the one or more edges of the first window includes:

in accordance with a determination that the first user input satisfies one or more expansion criteria, resizing one dimension of the first window to two parallel edges of the display area; and

in accordance with a determination that the first user input does not satisfy the one or more expansion criteria, resizing the one dimension of the first window to one edge of the display area.

74. The electronic device of any of claims 64-66, wherein resizing the one or more dimensions of the first window that correspond to the one or more edges of the first window includes:

in accordance with a determination that the first user input satisfies one or more expansion criteria, resizing a first dimension of the first window to a first set of two parallel edges of the display area and resizing a second dimension of the first window to a second set of parallel edges of the display area, wherein the first and second sets of parallel edges of the display area are distinct; and

in accordance with a determination that the first user input does not satisfy the one or more expansion criteria, resizing the first dimension of the first window to a first edge of the display area and the second dimension of the first window to a second edge of the display area.

75. The electronic device of any of claims 64-66, wherein a magnitude of the movement vector associated with the first user input is less than a distance between the one or more edges of the first window and one or more corresponding edges of the display area, and

wherein the one or more edges of the first window are not co-located with the one or more corresponding edges of the display area after resizing the one or more dimensions of the first window that correspond to the one or more edges of the first window based on the movement vector associated with the first user input.

76. The electronic device of any of claims 64-66, wherein the processing unit is further configured to:

in response to detecting the first user input:

in accordance with a determination that the first user input corresponds to a third input type, move one or more edges of the first window to one or more corresponding edges of the display area.

77. A method comprising:
- at a device with one or more processors; non-transitory memory, a display, and an input device:
    - displaying, on the display, a first window associated with a first application within a display area;
    - detecting a first user input, via the input device, that corresponds to a request to add a second window associated with the first application; and
    - in response to detecting the first user input:
      - in accordance with a determination that the first window is displayed within the display area in full screen mode, adding the second window as a new tab within a tab bar associated with the first window; and
      - in accordance with a determination that the first window is displayed within the display area in windowed mode, displaying the second window separate from the first window within the display area.
78. The method of claim 77, wherein the first user input corresponds to selection of an affordance within the first window that causes an instruction to be sent to the first application to generate a new window associated with the first application.
79. The method of claim 77, wherein the first user input corresponds to a combination of one or more keystrokes that causes an instruction to be sent to the first application to generate a new window associated with the first application.
80. The method of any of claims 77-79, wherein adding the second window as the new tab within the tab bar associated with the first window includes displaying the second window as a tab within the second window as the new tab within the tab bar associated with the first window after the second application generates the second window.
81. The method of any of claims 77-80, wherein adding the second window as a new tab within a tab bar associated with the first window includes:
- determining whether a global tabbed window functionality is enabled; and
  - in accordance with the determination that the first window is displayed within the display area in full screen mode and in accordance with a determination that the global tabbed

window setting is enabled, adding the second window as a new tab within a tab bar associated with the first window.

82. The method of any of claims 80-81, wherein the first application is not included on an opt-out list for the global tabbed window functionality.

83. The method of any of claims 77-79, further comprising:  
after displaying the second window separate from the first window within the display area, detecting a second user input, via the input device, to merge the first and second windows into a single tabbed window; and  
in response to detecting the second user input, replacing display of the separate first and second windows with a merged window that includes a tab bar with a first tab associated with the first window and a second tab associated with the second window.

84. The method of claim 83, wherein the tab bar is displayed in a chrome region of the merged window, and wherein the tab bar is generated and controlled independent of the first application.

85. The method of any of claims 83-84, further comprising:  
after displaying the merged window, detecting a third user input, via the input device, to close the merged window; and  
in response to detecting the third user input, sending window close instructions to the first application to close the first and second windows.

86. The method of any of claims 83-84, further comprising:  
after displaying the merged window, detecting a third user input, via the input device, dragging a third window separate from the merged window into the tab bar of the merged window, wherein the third window is associated with a second application; and  
in response to the third user input, adding a new tab associated with the third window to the tab bar of the merged window.

87. The method of any of claims 83-84, further comprising:  
after displaying the merged window, detecting a third user input, via the input device, dragging the merged window into a third window separate from the merged window, wherein the third window is associated with a second application; and

in response to the third user input, adding a new tab associated with the third window to the tab bar of the merged window.

88. The method of any of claims 86-87, further comprising:

after adding the new tab associated with the third window to the tab bar of the merged window, detecting a fourth user input, via the input device, to close the merged window; and

in response to detecting the fourth user input, sending a first window close instruction to the first application to close the first and second windows and a second window close instruction to the second application to close the third window.

89. The method of any of claims 77-88, further comprising:

after detecting the first user input, detecting a subsequent user input, via the input device, to add a third window associated with a second application; and

in response to detecting the subsequent user input:

in accordance with a determination that the first window is displayed within the display area in full screen mode, adding the third window as a new tab in a tab bar associated with the first window; and

in accordance with a determination that the first window is displayed within the display area in windowed mode, displaying, on the display, the third window as a separate window within the display area.

90. An electronic device comprising:

a display;

an input device;

one or more processors;

non-transitory memory; and

one or more programs, wherein the one or more programs are stored in the memory and configured to be executed by the one or more processors, the one or more programs including instructions for:

displaying, on the display, a first window associated with a first application within a display area;

detecting a first user input, via the input device, that corresponds to a request to add a second window associated with the first application; and

in response to detecting the first user input:

in accordance with a determination that the first window is displayed within the display area in full screen mode, adding the second window as a new tab within a tab bar associated with the first window; and

in accordance with a determination that the first window is displayed within the display area in windowed mode, displaying the second window separate from the first window within the display area.

91. A non-transitory computer readable storage medium storing one or more programs, the one or more programs comprising instructions, which, when executed by an electronic device with a display, and an input device, cause the electronic device to:

display, on the display, a first window associated with a first application within a display area;

detect a first user input, via the input device, that corresponds to a request to add a second window associated with the first application; and

in response to detecting the first user input:

in accordance with a determination that the first window is displayed within the display area in full screen mode, add the second window as a new tab within a tab bar associated with the first window; and

in accordance with a determination that the first window is displayed within the display area in windowed mode, display, on the display, the second window separate from the first window within the display area.

92. An electronic device comprising:

a display;

an input device;

means for displaying, on the display, a first window associated with a first application within a display area;

means for detecting a first user input, via the input device, that corresponds to a request to add a second window associated with the first application;

means, responsive to detecting the first user input, for adding the second window as a new tab within a tab bar associated with the first window in accordance with a determination that the first window is displayed within the display area in full screen mode; and

means, responsive to detecting the first user input, for displaying the second window separate from the first window within the display area in accordance with a determination that the first window is displayed within the display area in windowed mode.

93. An electronic device comprising:  
a display;  
an input device;  
one or more processors;  
non-transitory memory; and  
one or more programs, wherein the one or more programs are stored in the memory and configured to be executed by the one or more processors, the one or more programs including instructions for performing or causing performance of any of the methods of claims 77-89.
94. A non-transitory computer readable storage medium storing one or more programs, the one or more programs comprising instructions, which, when executed by an electronic device with a display, and an input device, cause the electronic device to perform or cause performance of any of the methods of claims 77-89.
95. An electronic device comprising:  
a display;  
an input device; and  
means for performing or causing performance of any of the methods of claims 77-89.
96. A graphical user interface on an electronic device with a display, an input device, a non-transitory memory, and one or more processors to execute one or more programs stored in the non-transitory memory, the graphical user interface comprising user interfaces displayed in accordance with any of the methods of claims 77-89.
97. An information processing apparatus for use in an electronic device with a display and an input device, comprising:  
means for performing or causing performance of any of the methods of claims 77-89.
98. An electronic device comprising:  
a display unit configured to display a user interface;

one or more input units configured to receive inputs; and

a processing unit coupled with the display unit and the one or more input units, the processing unit configured to:

- enable display of, on the display unit, a first window associated with a first application within a display area;
- detect a first user input, via the one or more input units, that corresponds to a request to add a second window associated with the first application; and
- in response to detecting the first user input:
  - in accordance with a determination that the first window is displayed within the display area in full screen mode, add the second window as a new tab within a tab bar associated with the first window; and
  - in accordance with a determination that the first window is displayed within the display area in windowed mode, enable display of, on the display unit, the second window separate from the first window within the display area.

99. The electronic device of claim 98, wherein the first user input corresponds to selection of an affordance within the first window that causes an instruction to be sent to the first application to generate a new window associated with the first application.

100. The electronic device of claim 98, wherein the first user input corresponds to a combination of one or more keystrokes that causes an instruction to be sent to the first application to generate a new window associated with the first application.

101. The electronic device of claims 98-100, wherein adding the second window as the new tab within the tab bar associated with the first window includes displaying the second window as a tab within the second window as the new tab within the tab bar associated with the first window after the second application generates the second window.

102. The electronic device of claims 98-101, wherein adding the second window as a new tab within a tab bar associated with the first window includes:

- determining whether a global tabbed window functionality is enabled; and
- in accordance with the determination that the first window is displayed within the display area in full screen mode and in accordance with a determination that the global tabbed



window setting is enabled, adding the second window as a new tab within a tab bar associated with the first window.

103. The electronic device of claims 101-102, wherein the first application is not included on an opt-out list for the global tabbed window functionality.

104. The electronic device of claims 98-100, wherein the processing unit is further configured to:

after displaying the second window separate from the first window within the display area, detect a second user input, via the one or more input units, to merge the first and second windows into a single tabbed window; and

in response to detecting the second user input, replace display of the separate first and second windows with a merged window that includes a tab bar with a first tab associated with the first window and a second tab associated with the second window.

105. The electronic device of claim 104, wherein the tab bar is displayed in a chrome region of the merged window, and wherein the tab bar is generated and controlled independent of the first application.

106. The electronic device of claims 104-105, wherein the processing unit is further configured to:

after displaying the merged window, detect a third user input, via the one or more input units, to close the merged window; and

in response to detecting the third user input, send window close instructions to the first application to close the first and second windows.

107. The electronic device of claims 104-105, wherein the processing unit is further configured to:

after displaying the merged window, detecting a third user input, via the input device, drag a third window separate from the merged window into the tab bar of the merged window, wherein the third window is associated with a second application; and

in response to the third user input, add a new tab associated with the third window to the tab bar of the merged window.

108. The electronic device of claims 104-105, wherein the processing unit is further configured to:

after displaying the merged window, detecting a third user input, via the input device, drag the merged window into a third window separate from the merged window, wherein the third window is associated with a second application; and

in response to the third user input, add a new tab associated with the third window to the tab bar of the merged window.

109. The electronic device of claims 107-108, wherein the processing unit is further configured to:

after adding the new tab associated with the third window to the tab bar of the merged window, detect a fourth user input, via the one or more input units, to close the merged window; and

in response to detecting the fourth user input, send a first window close instruction to the first application to close the first and second windows and a second window close instruction to the second application to close the third window.

110. The electronic device of claims 98-108, wherein the processing unit is further configured to:

after detecting the first user input, detecting a subsequent user input, via the one or more input units, to add a third window associated with a second application; and

in response to detecting the subsequent user input:

in accordance with a determination that the first window is displayed within the display area in full screen mode, add the third window as a new tab in a tab bar associated with the first window; and

in accordance with a determination that the first window is displayed within the display area in windowed mode, enable display of, on the display unit, the third window as a separate window within the display area.

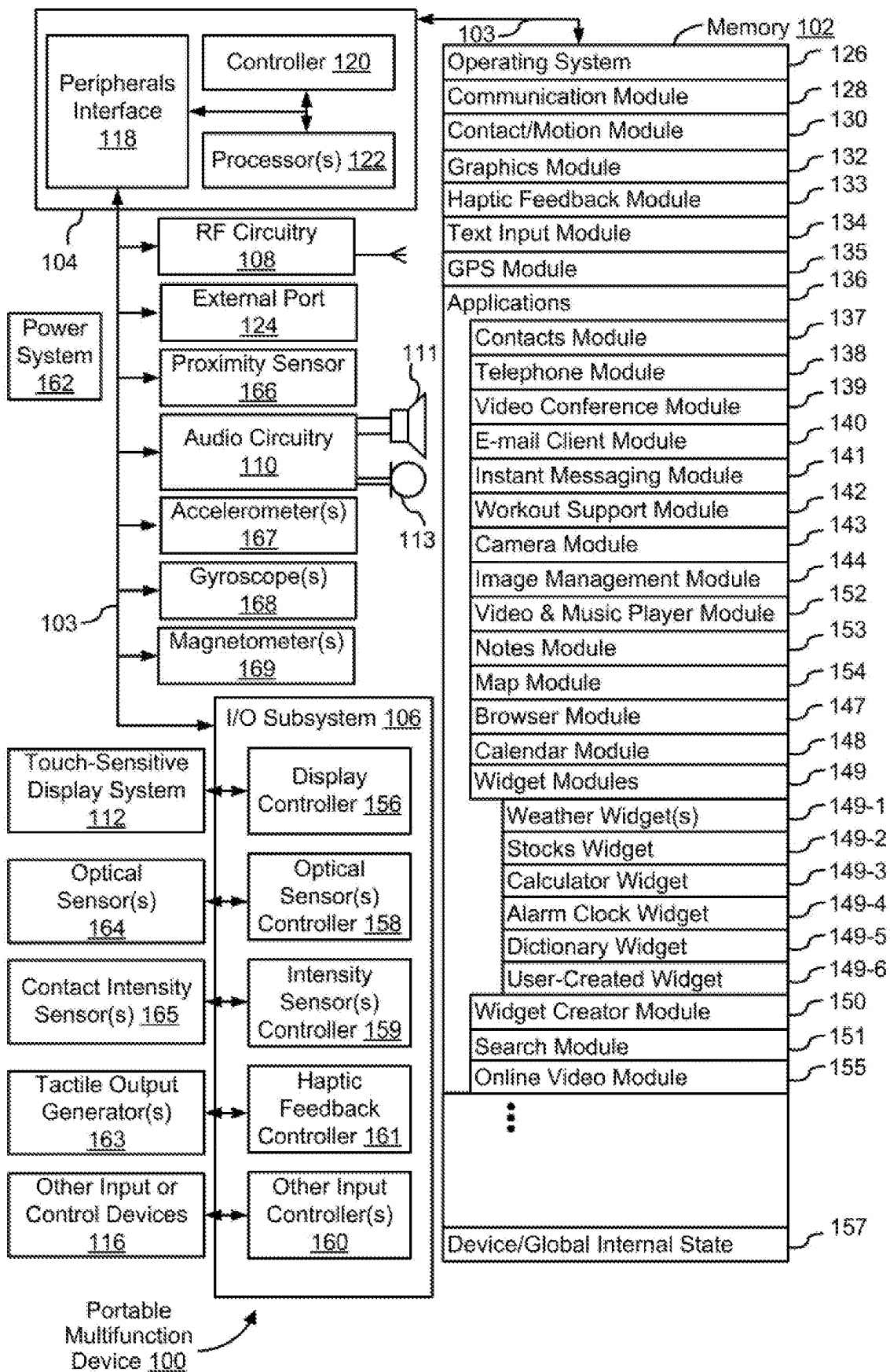

Figure 1A

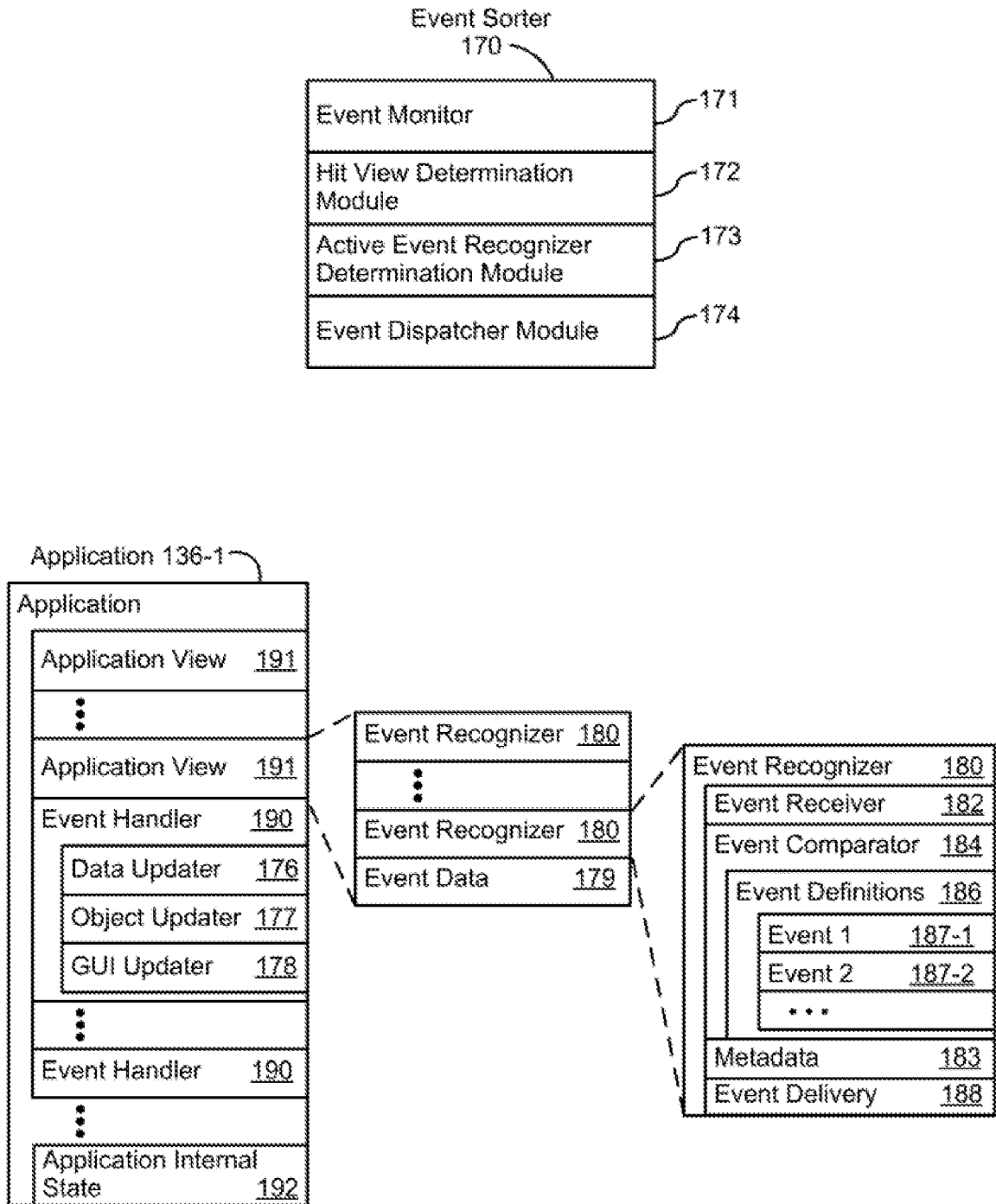
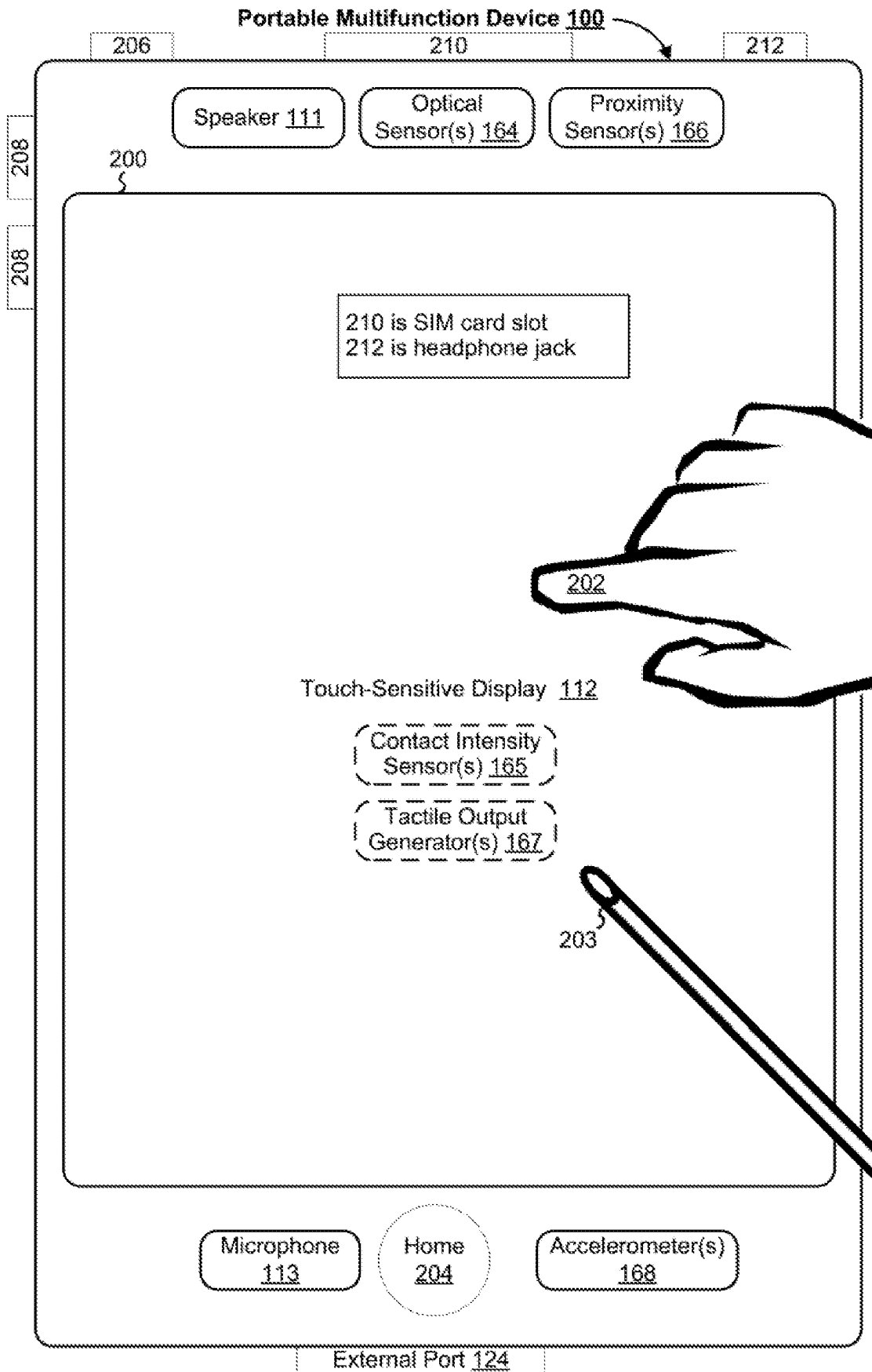

Figure 1B



**Figure 2**

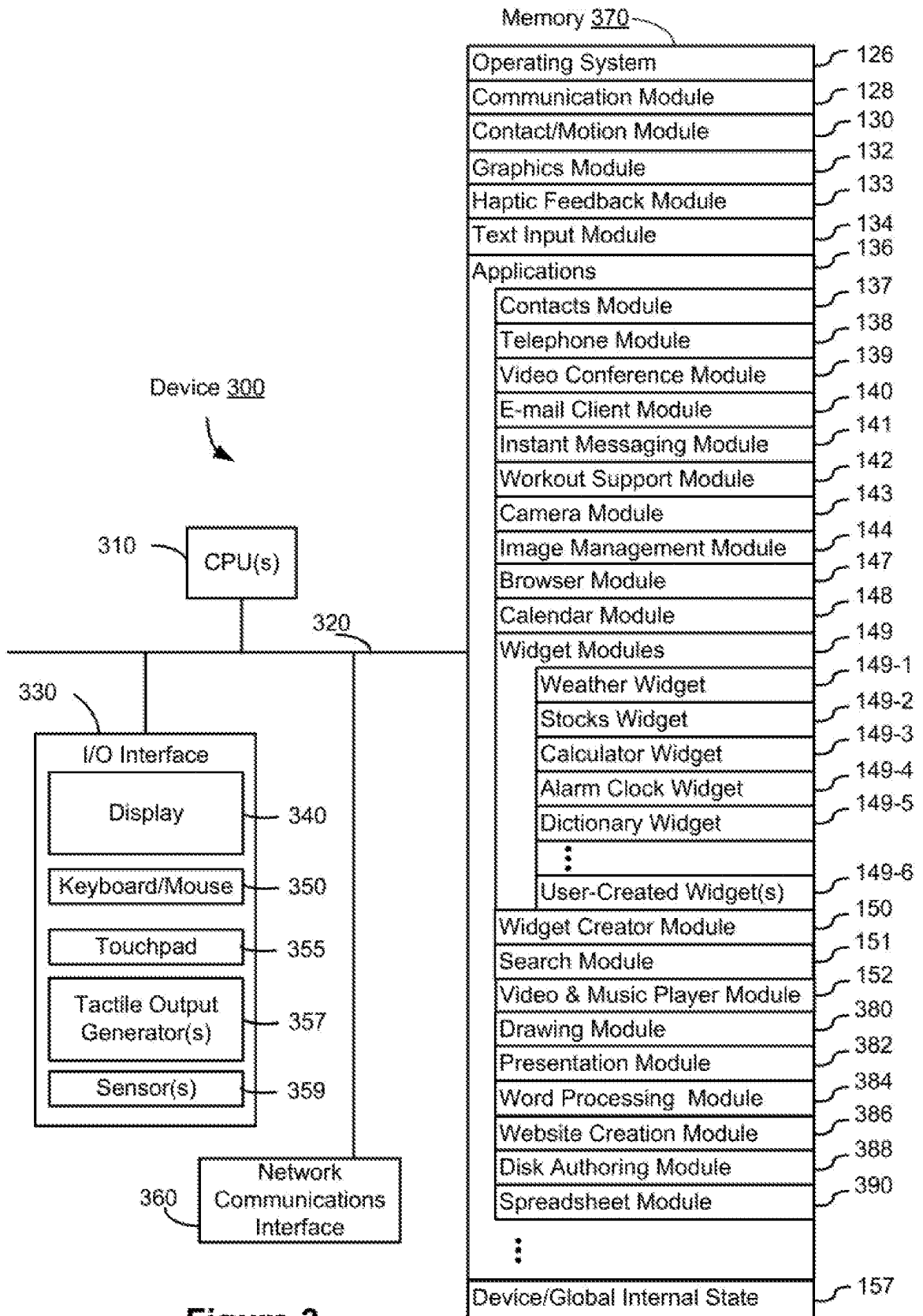

Figure 3

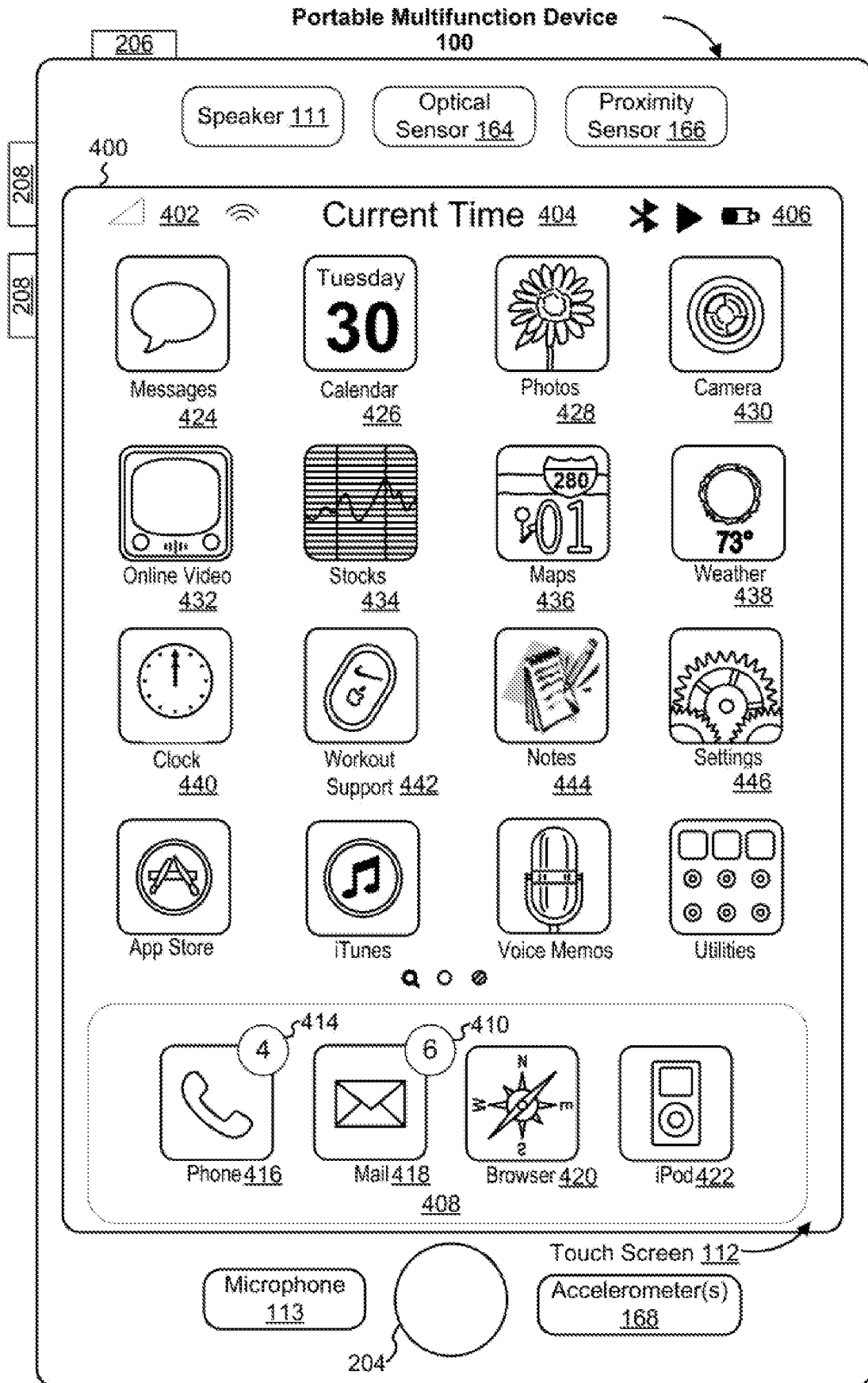

Figure 4A

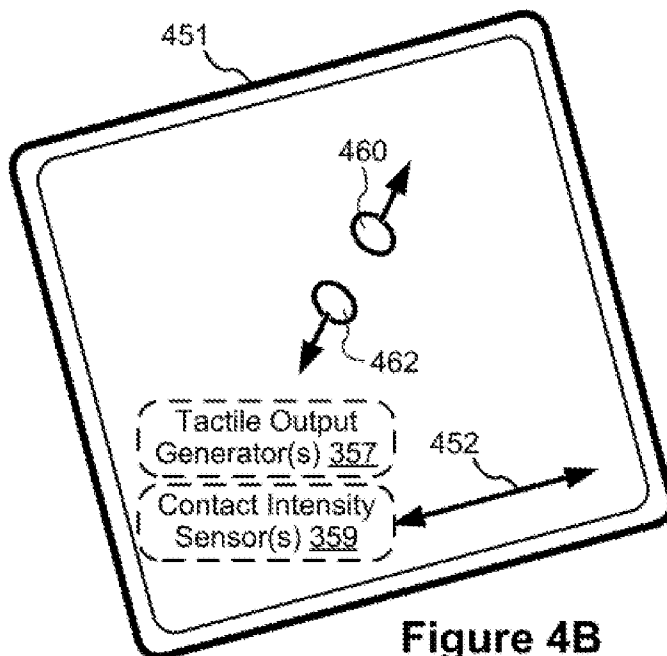
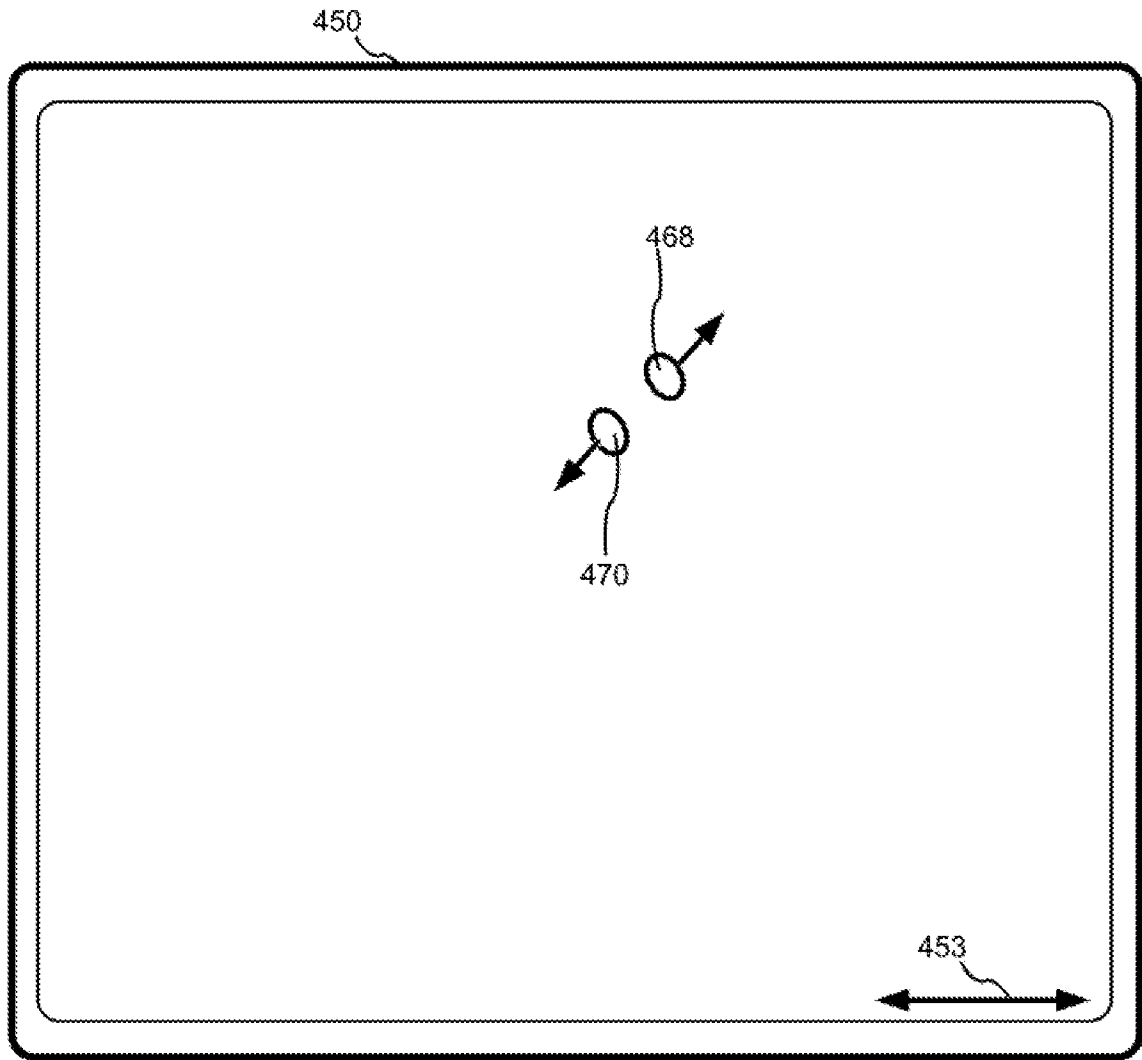

Figure 4B



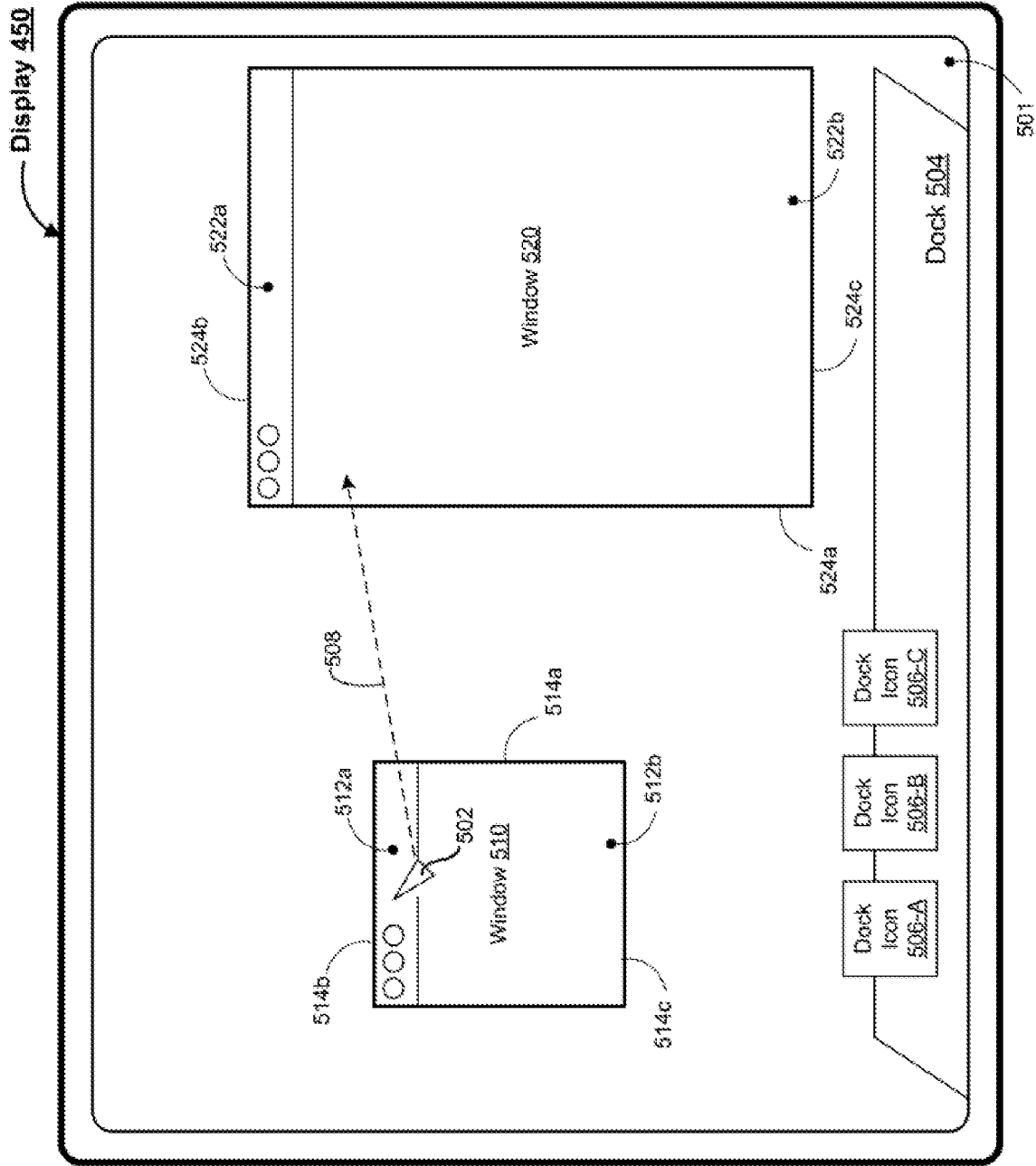
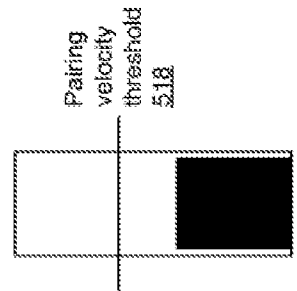
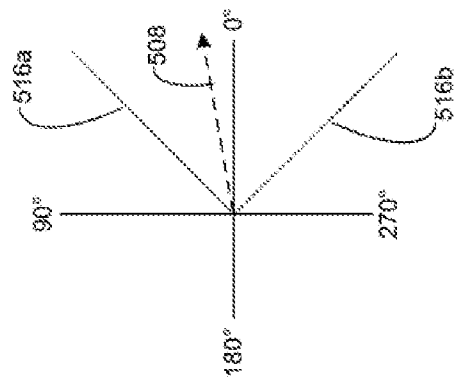

Figure 5A



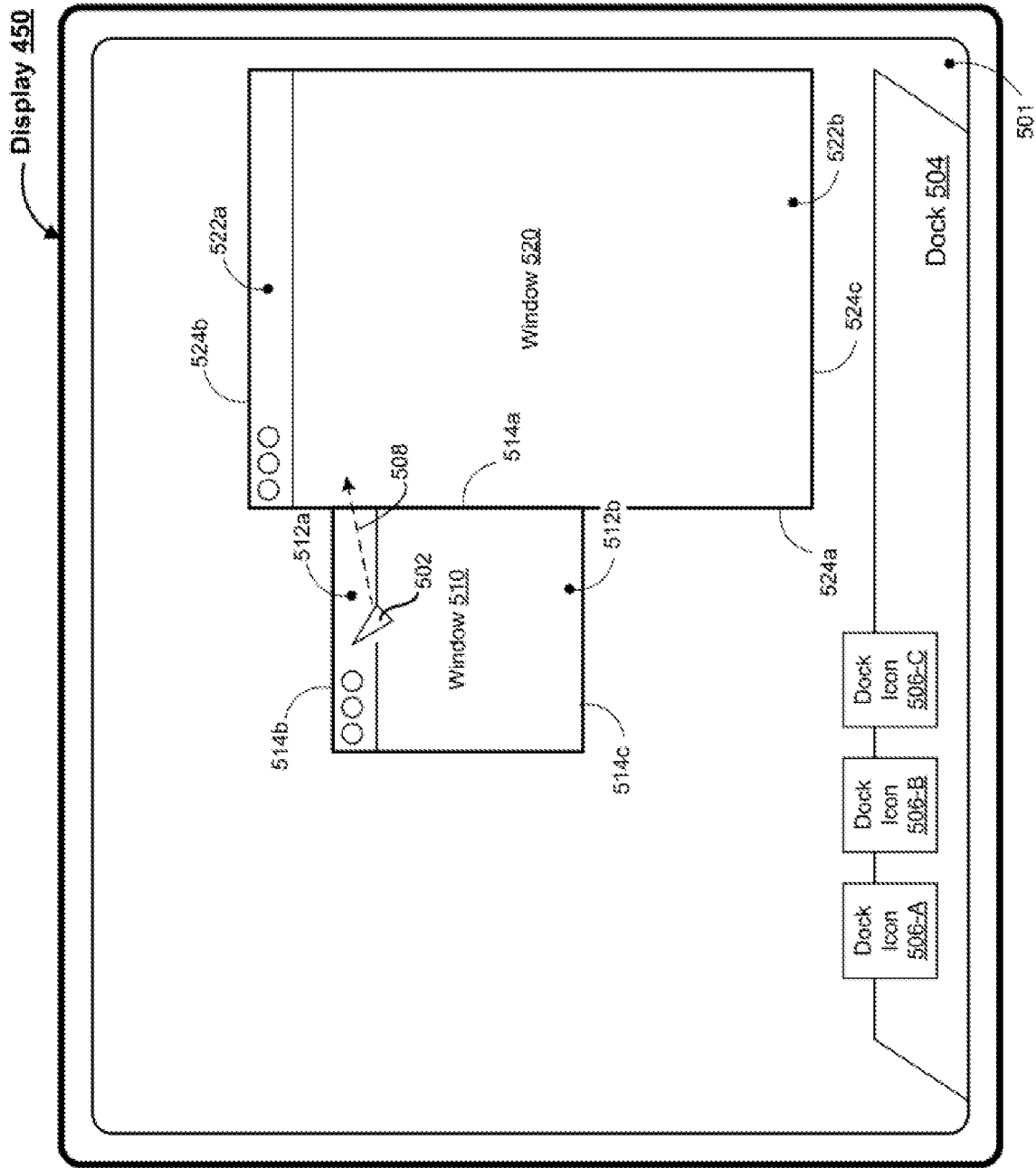

Figure 5B

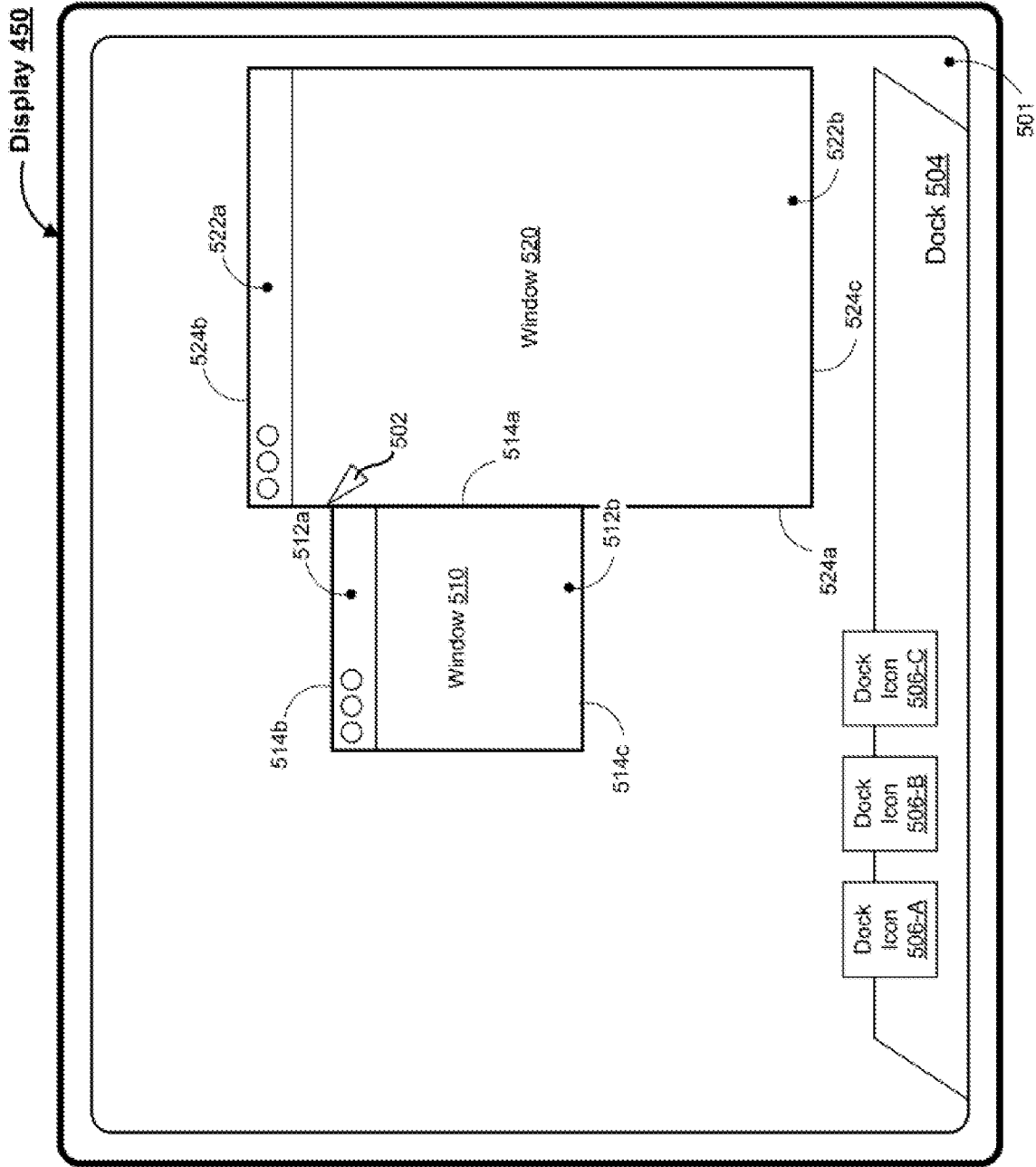

Figure 5C

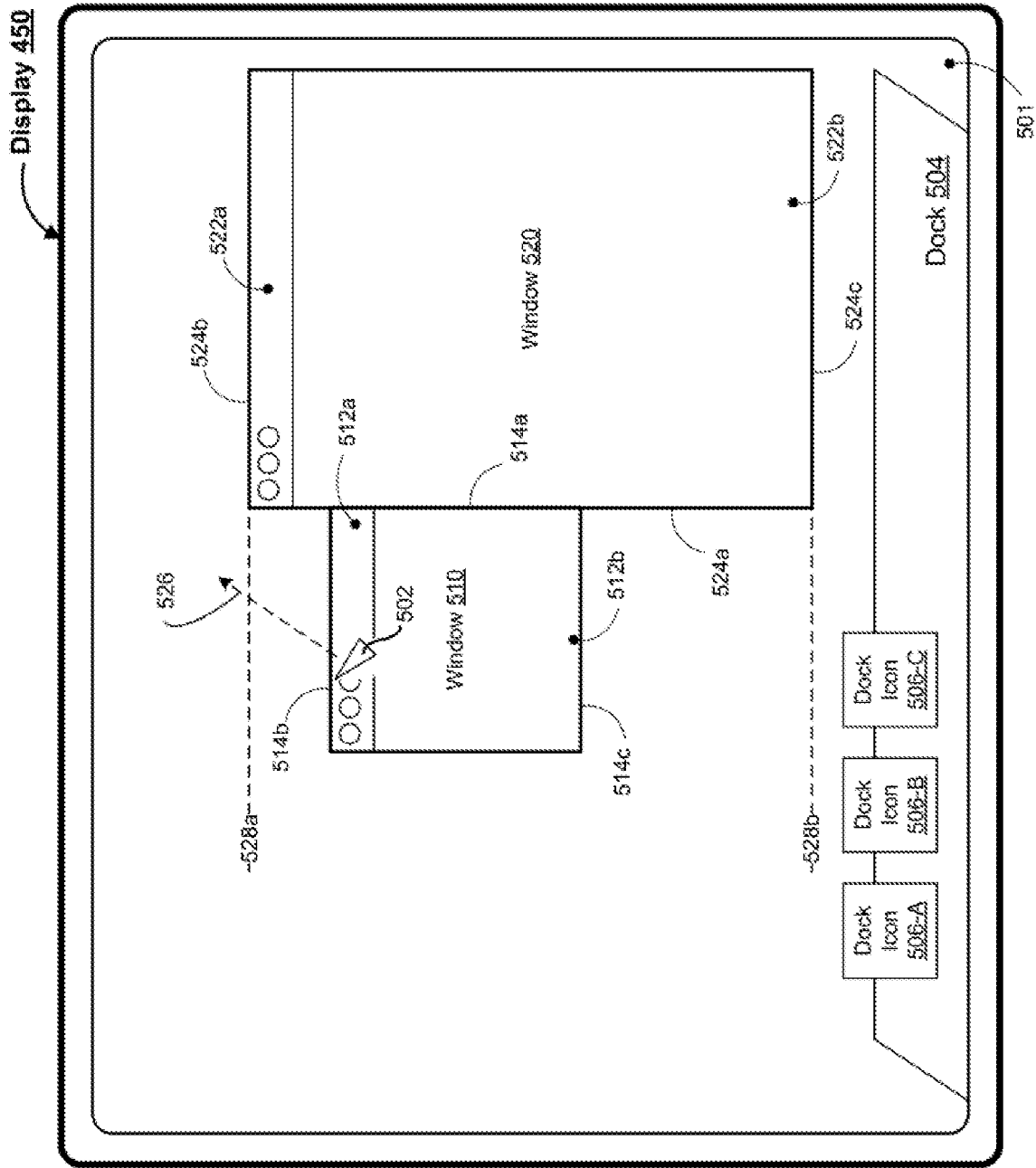
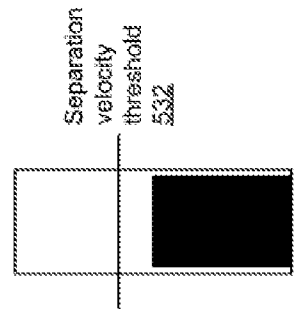
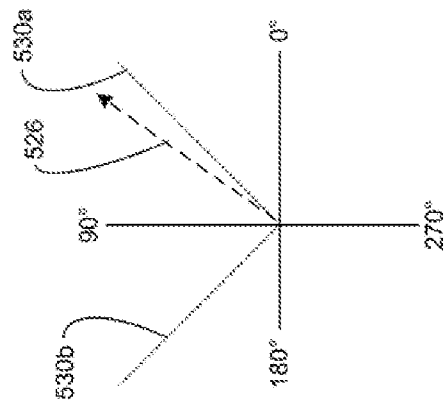

Figure 5D



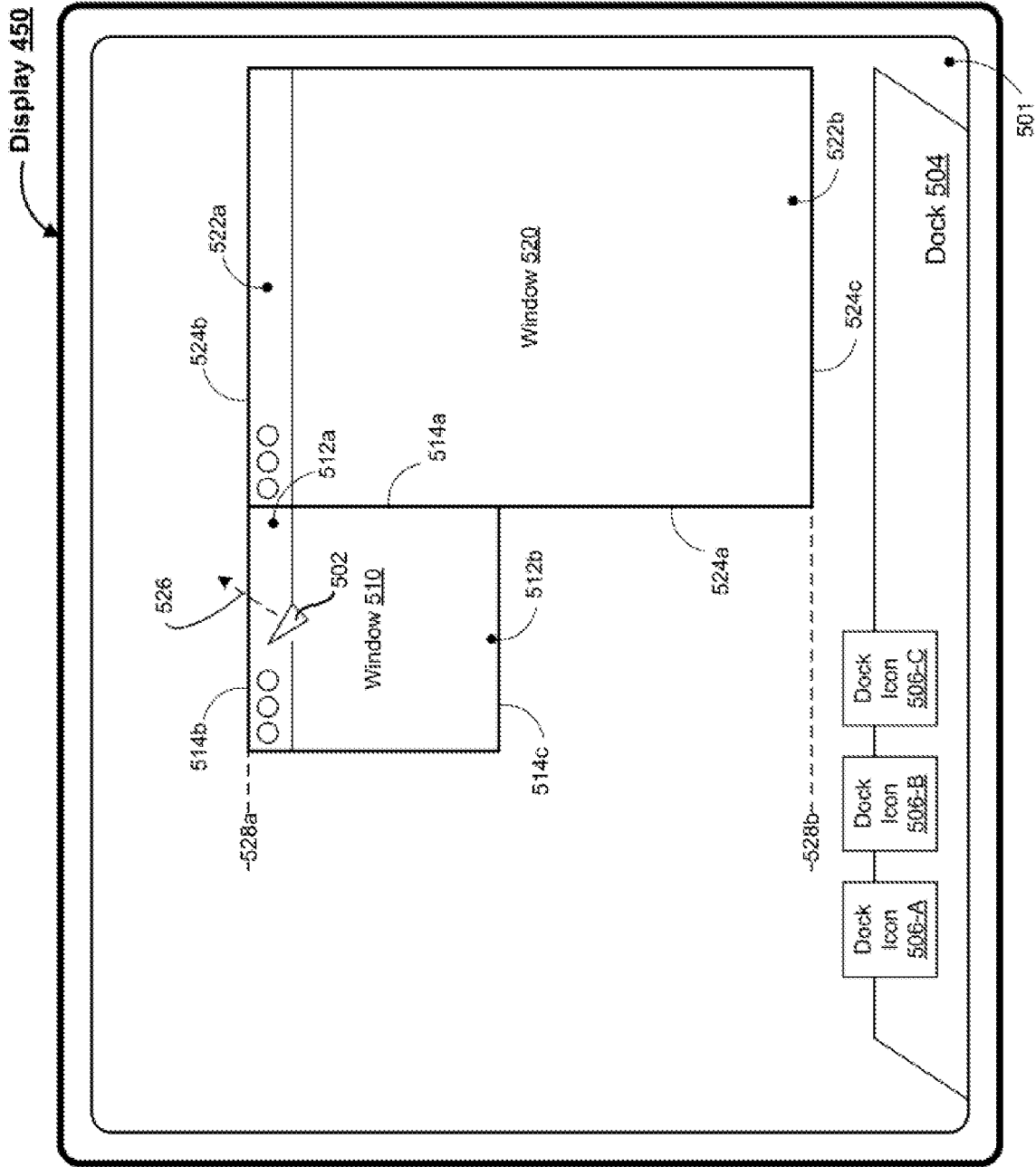

Figure 5E

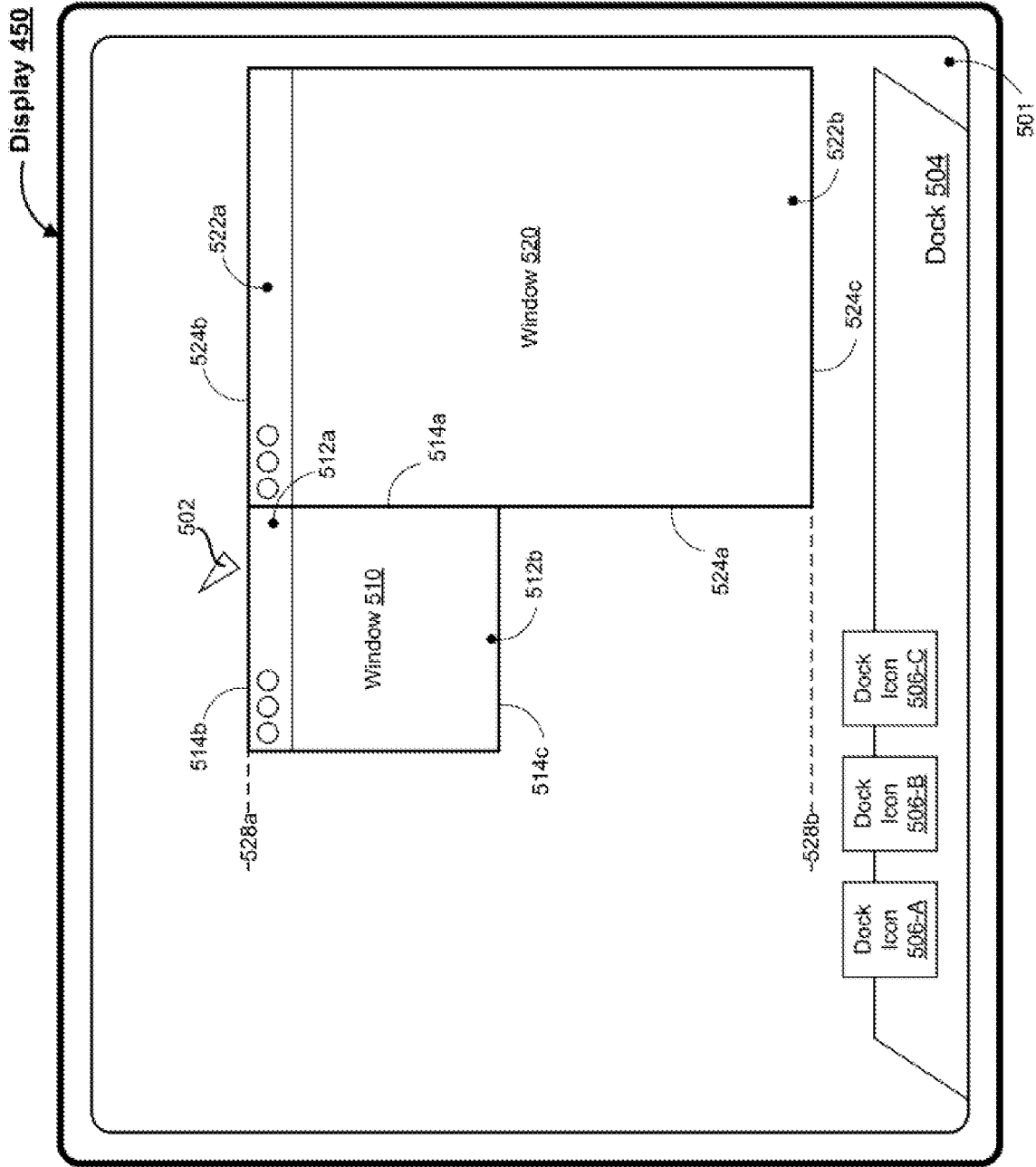

Figure 5F

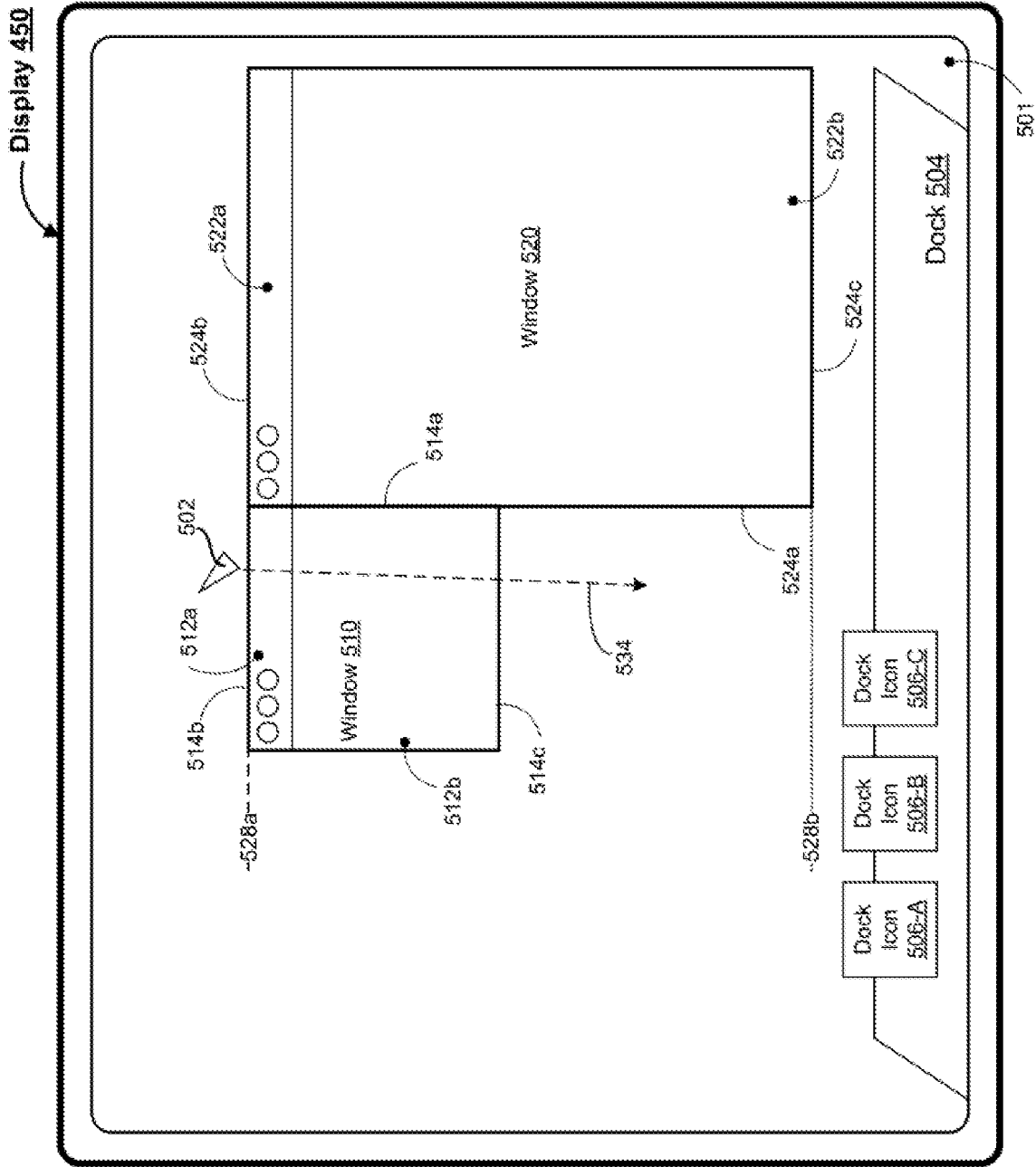
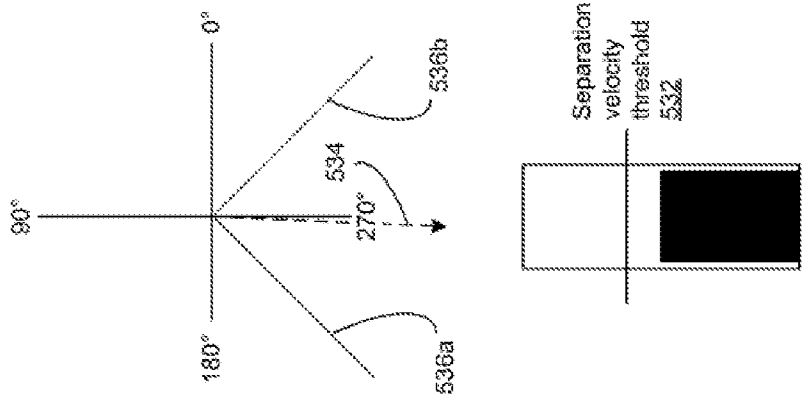

Figure 5G



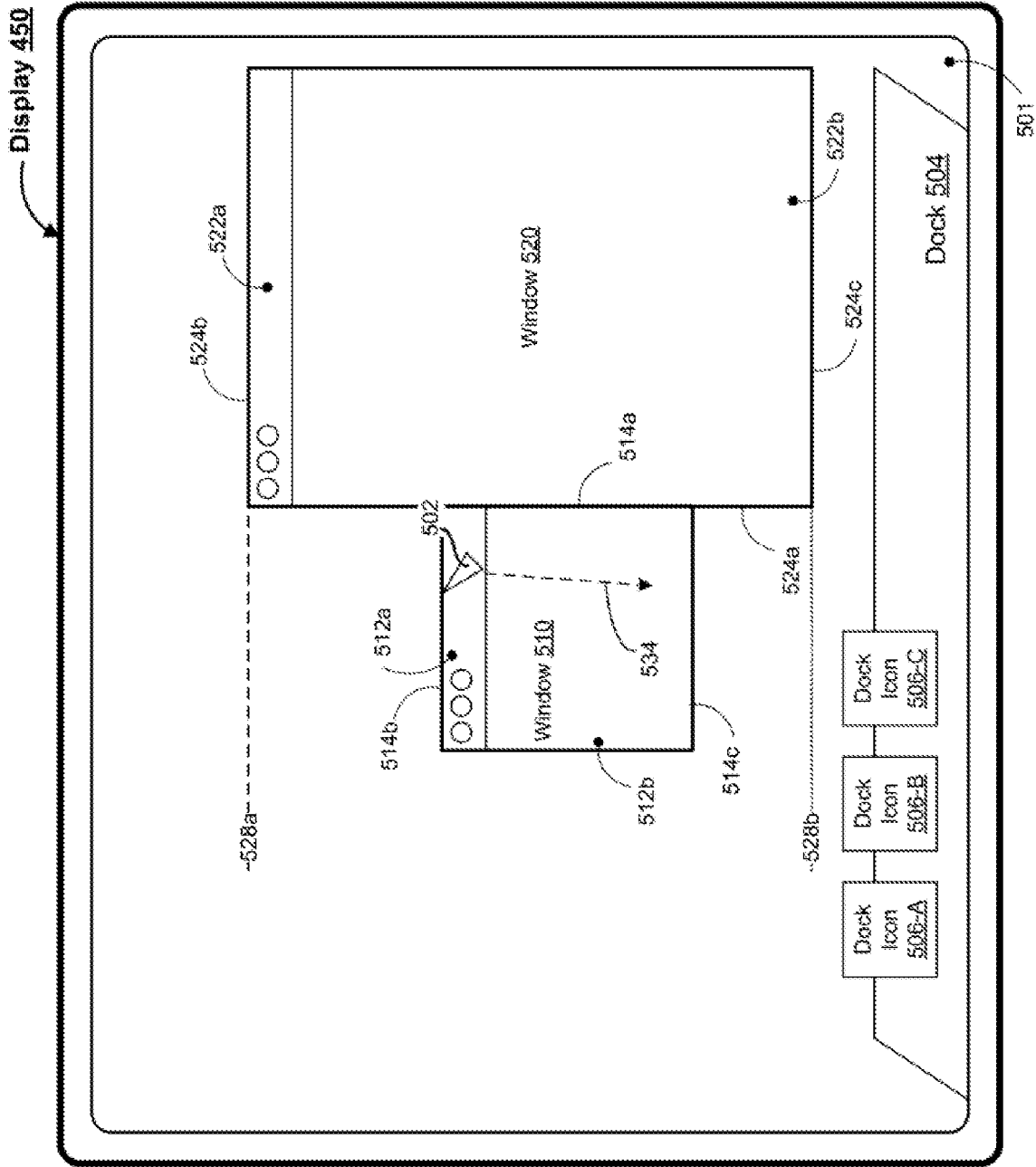

Figure 5H



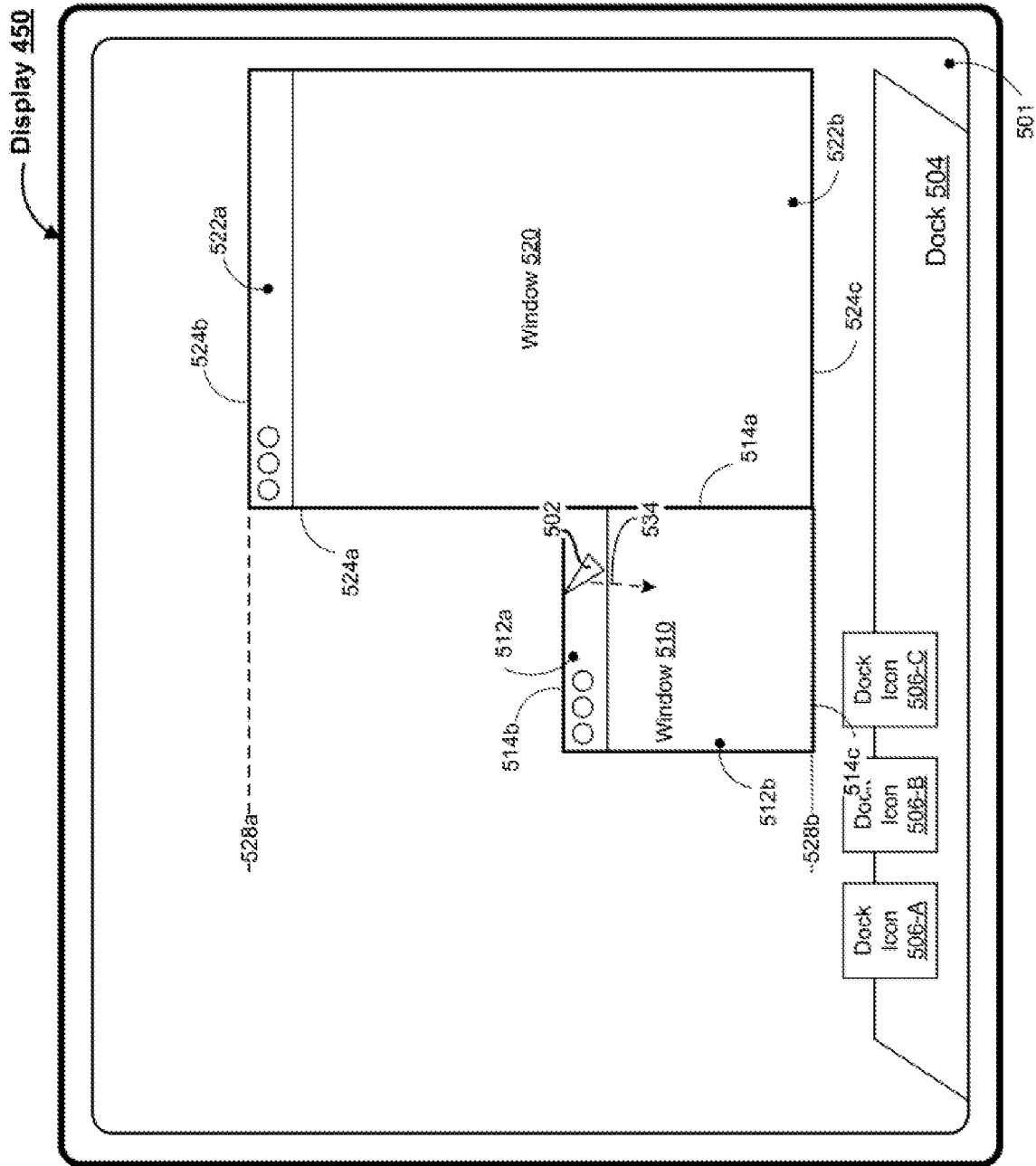

Figure 51

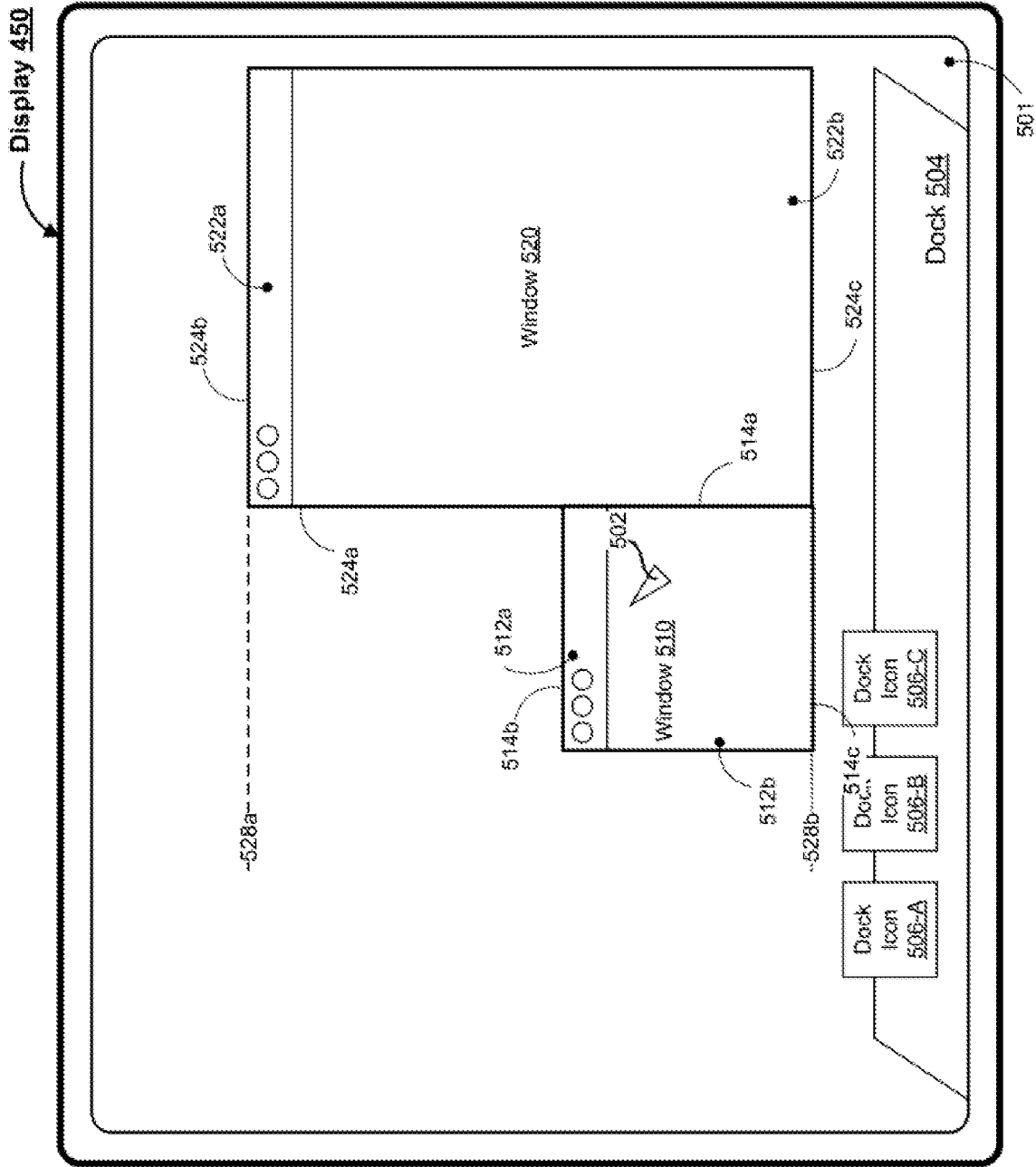

Figure 5J

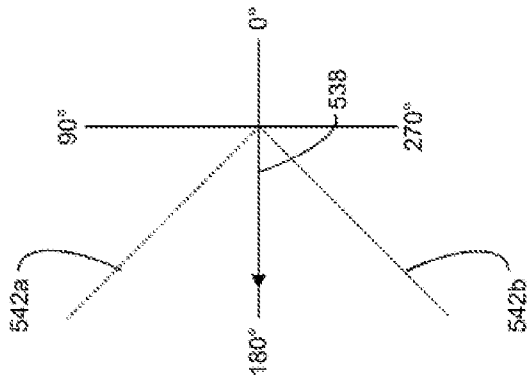
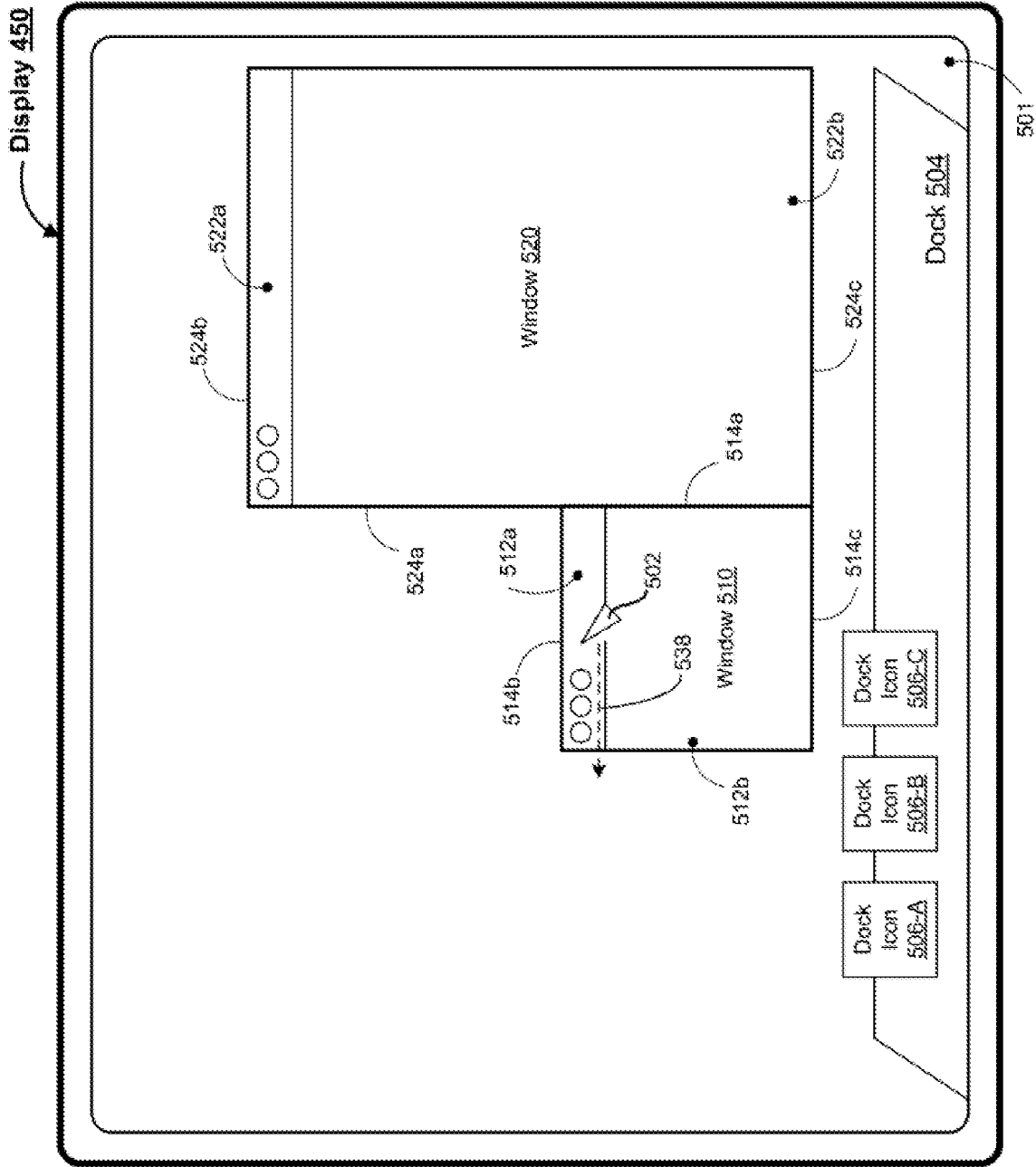

Figure 5K

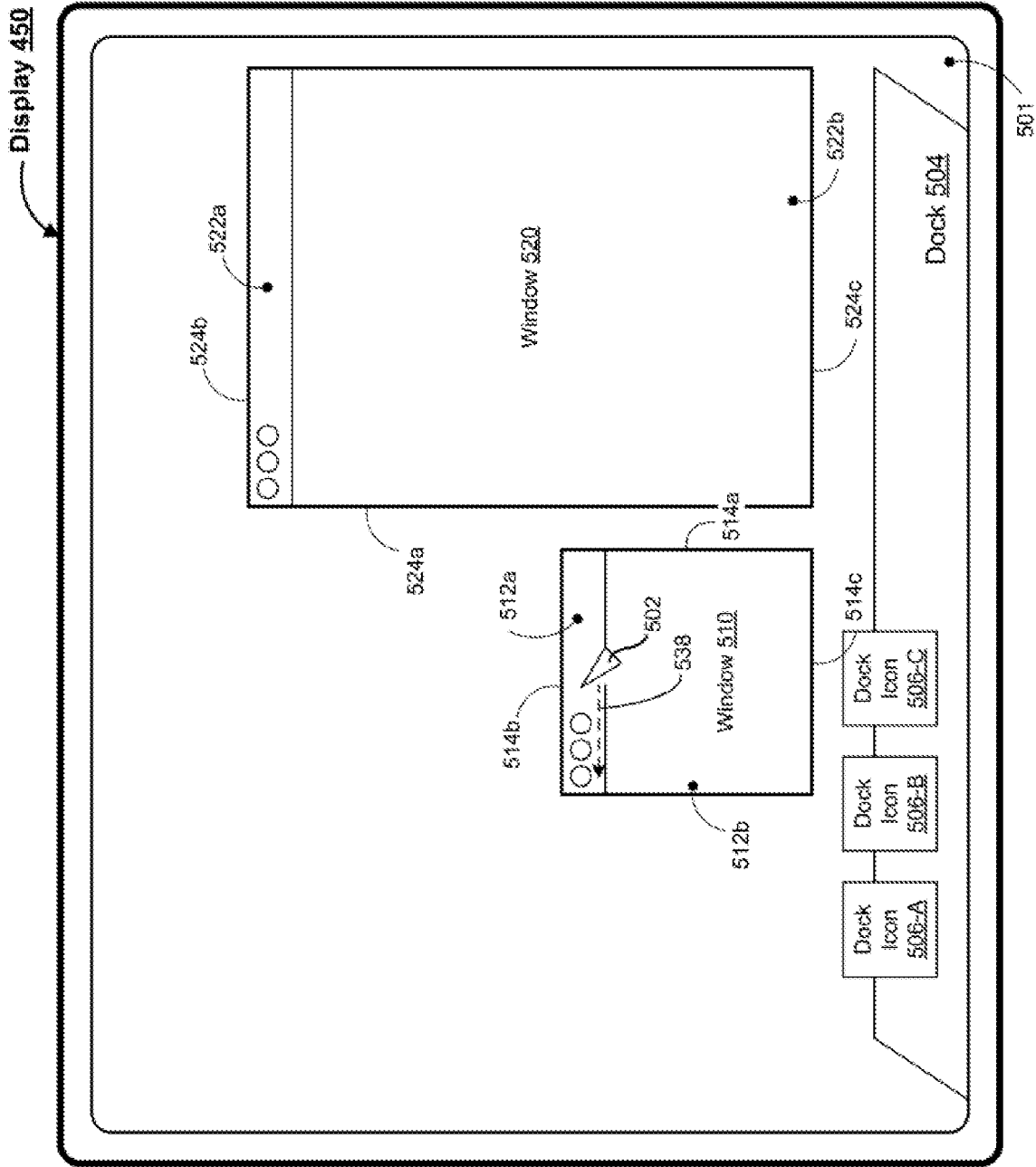

Figure 5L

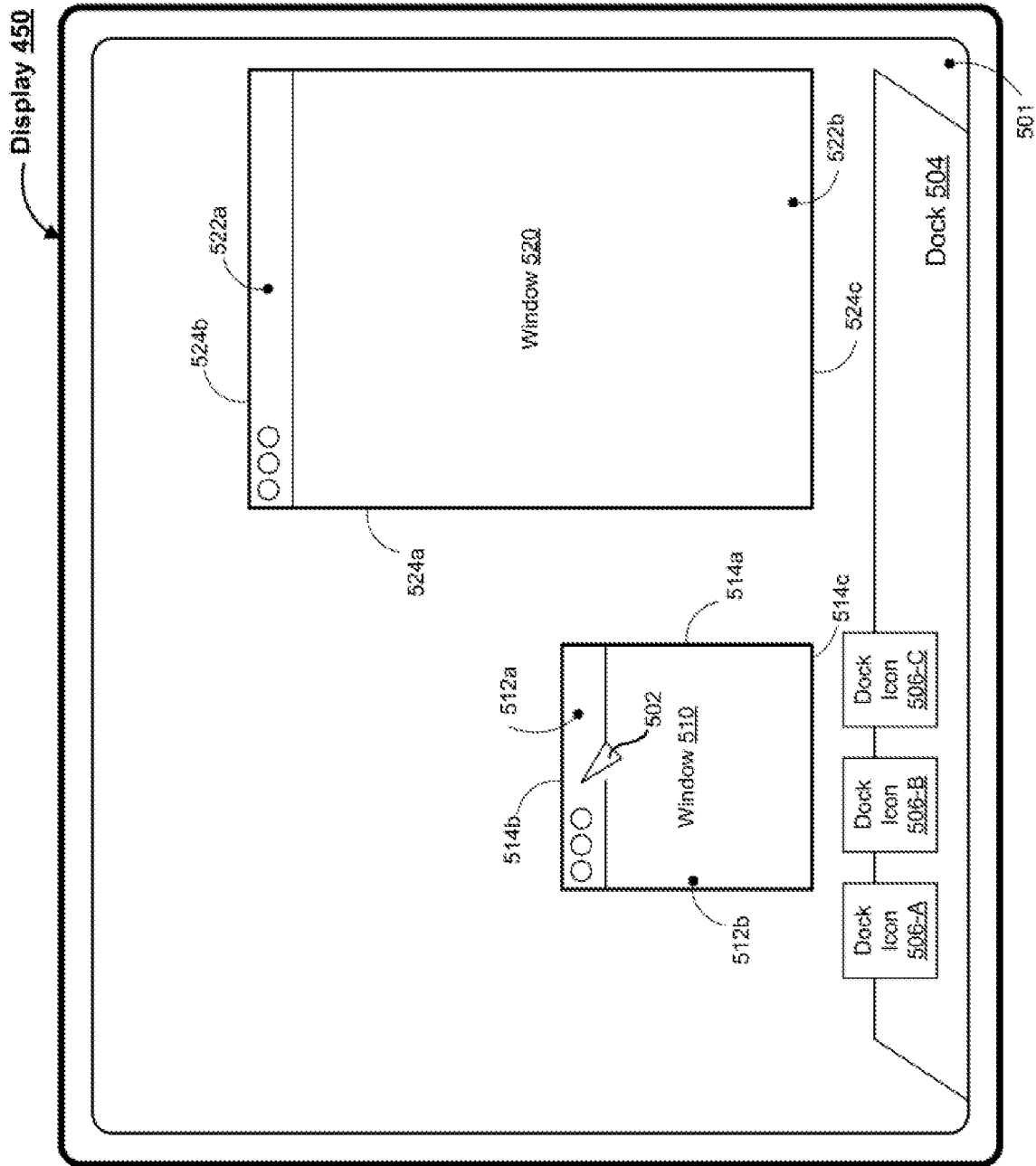

Figure 5M

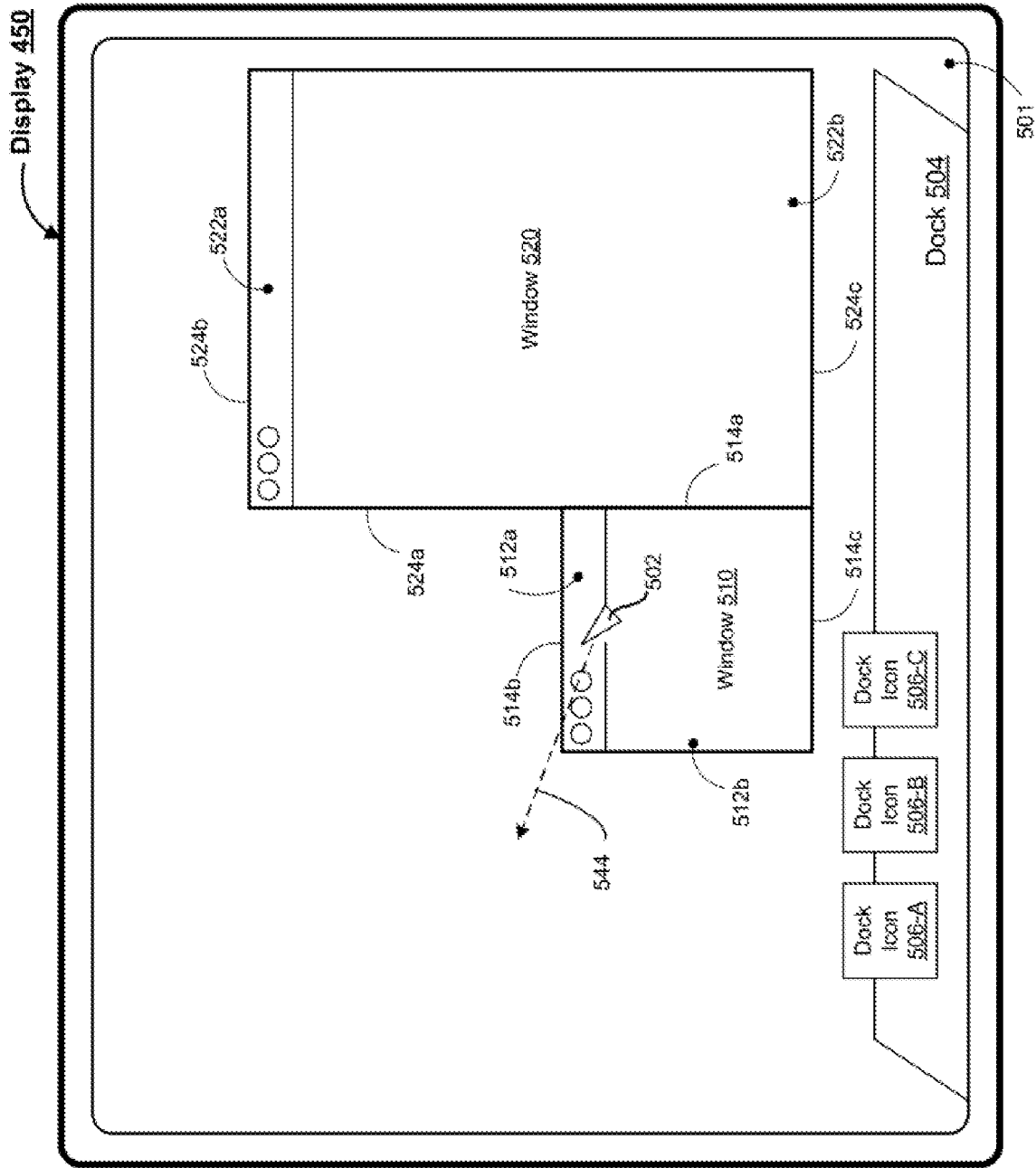
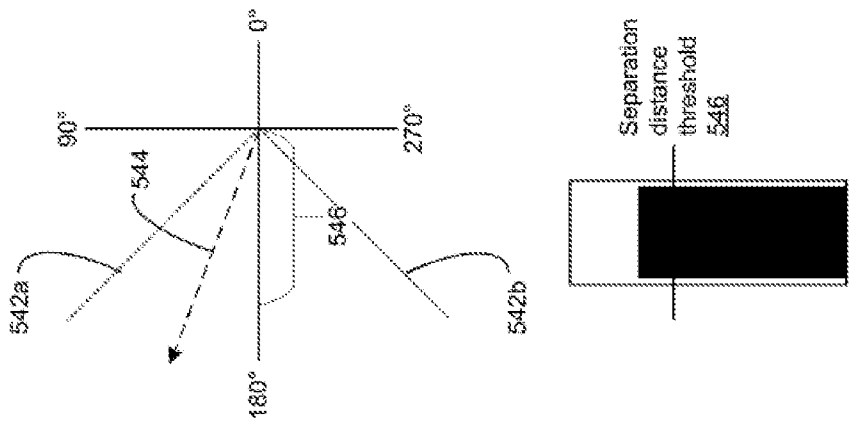

Figure 5N



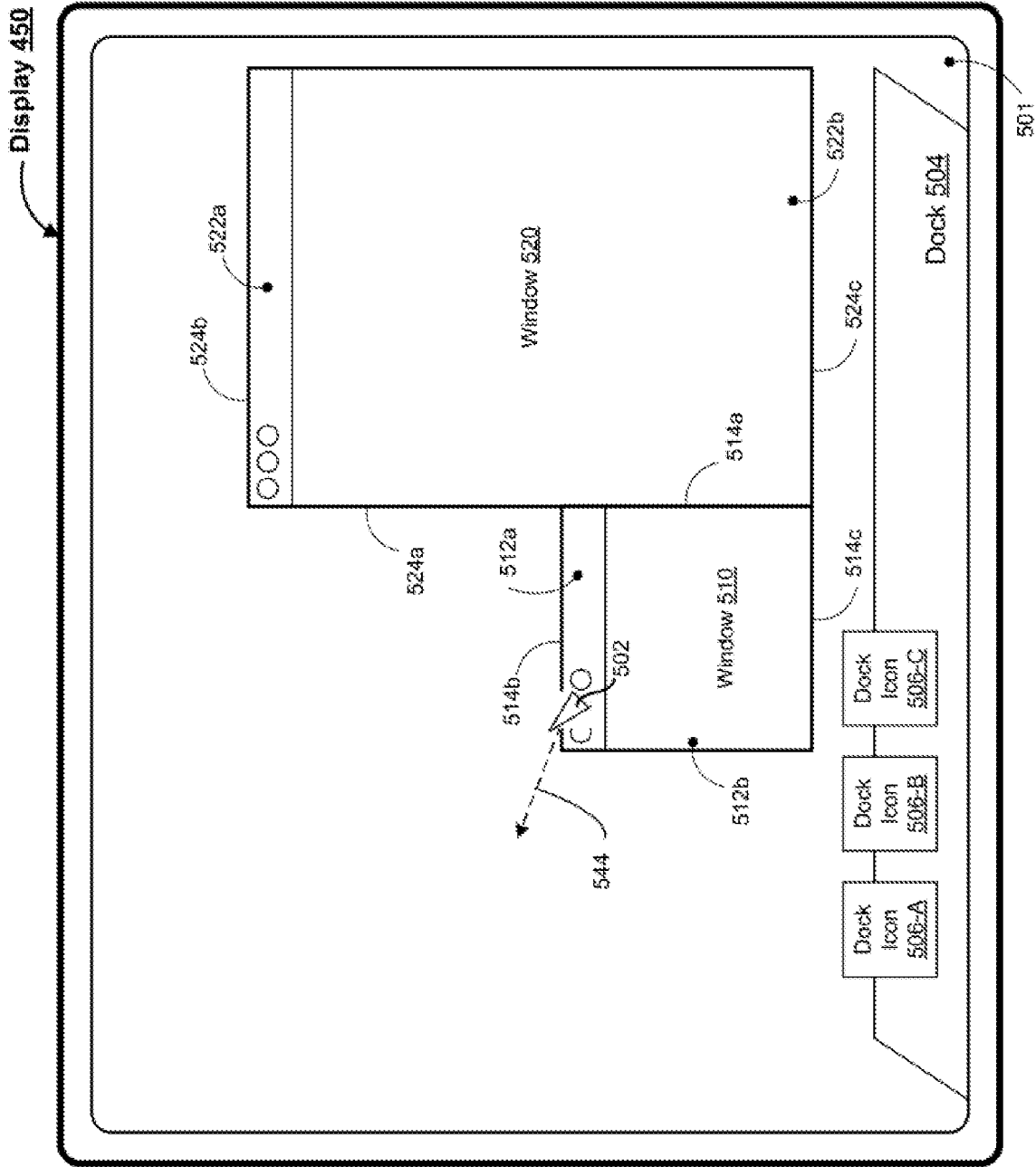

Figure 50

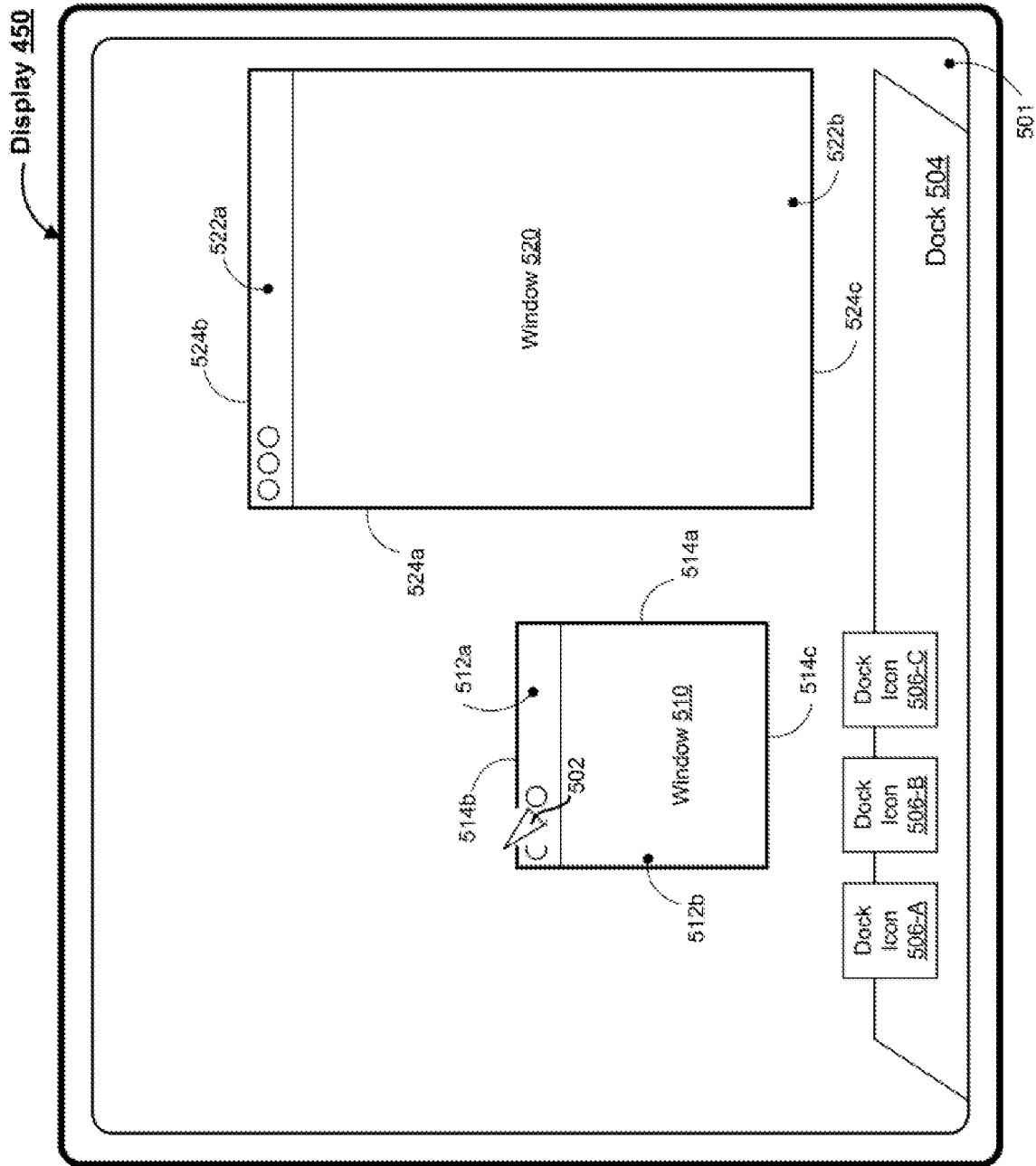

Figure 5P



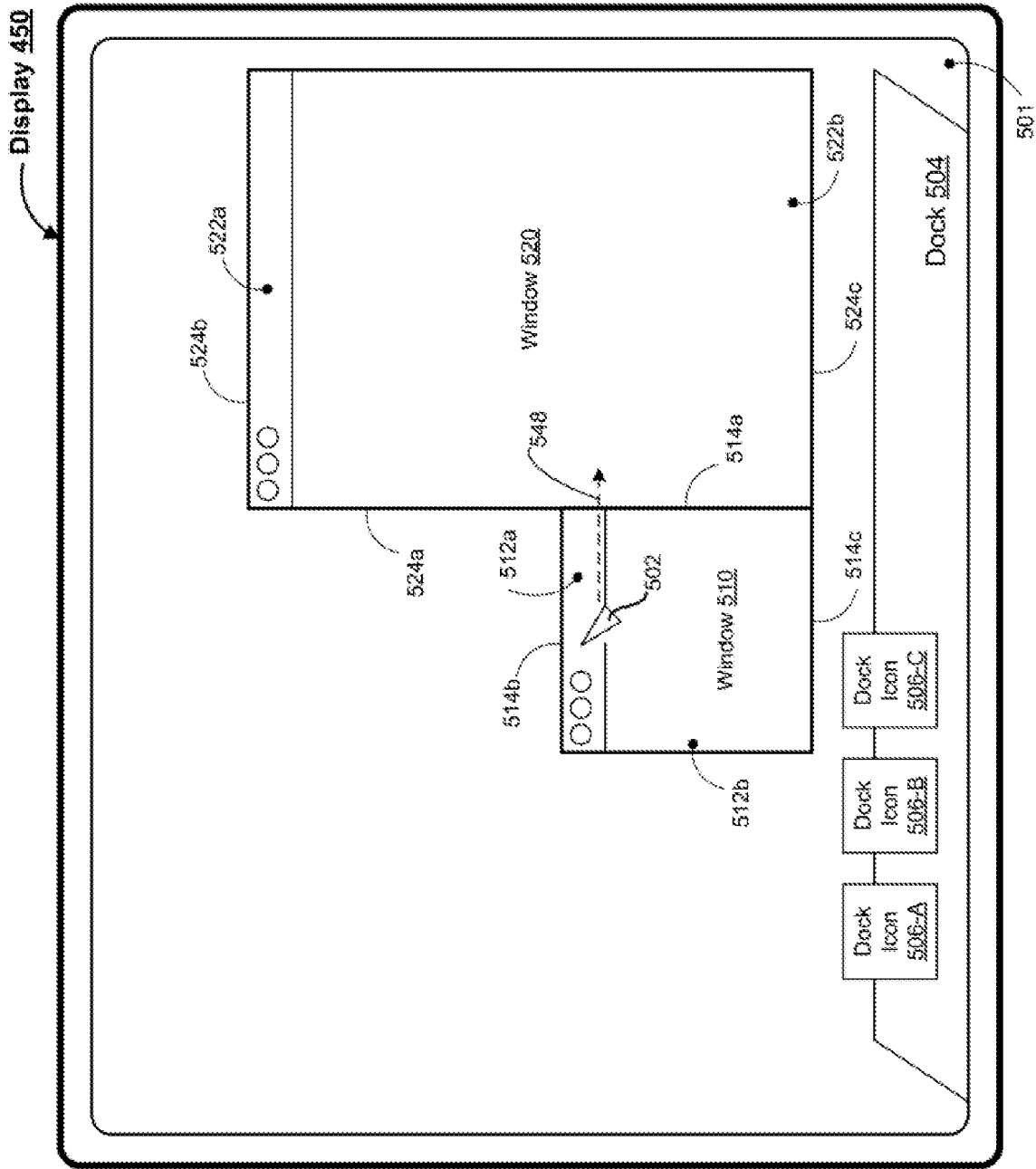
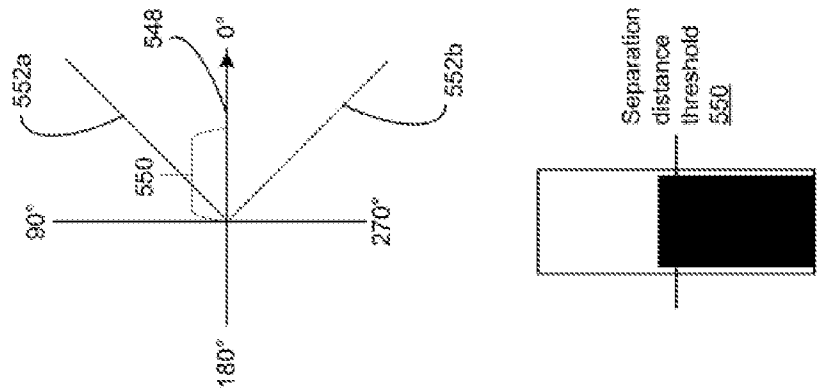

Figure 5Q



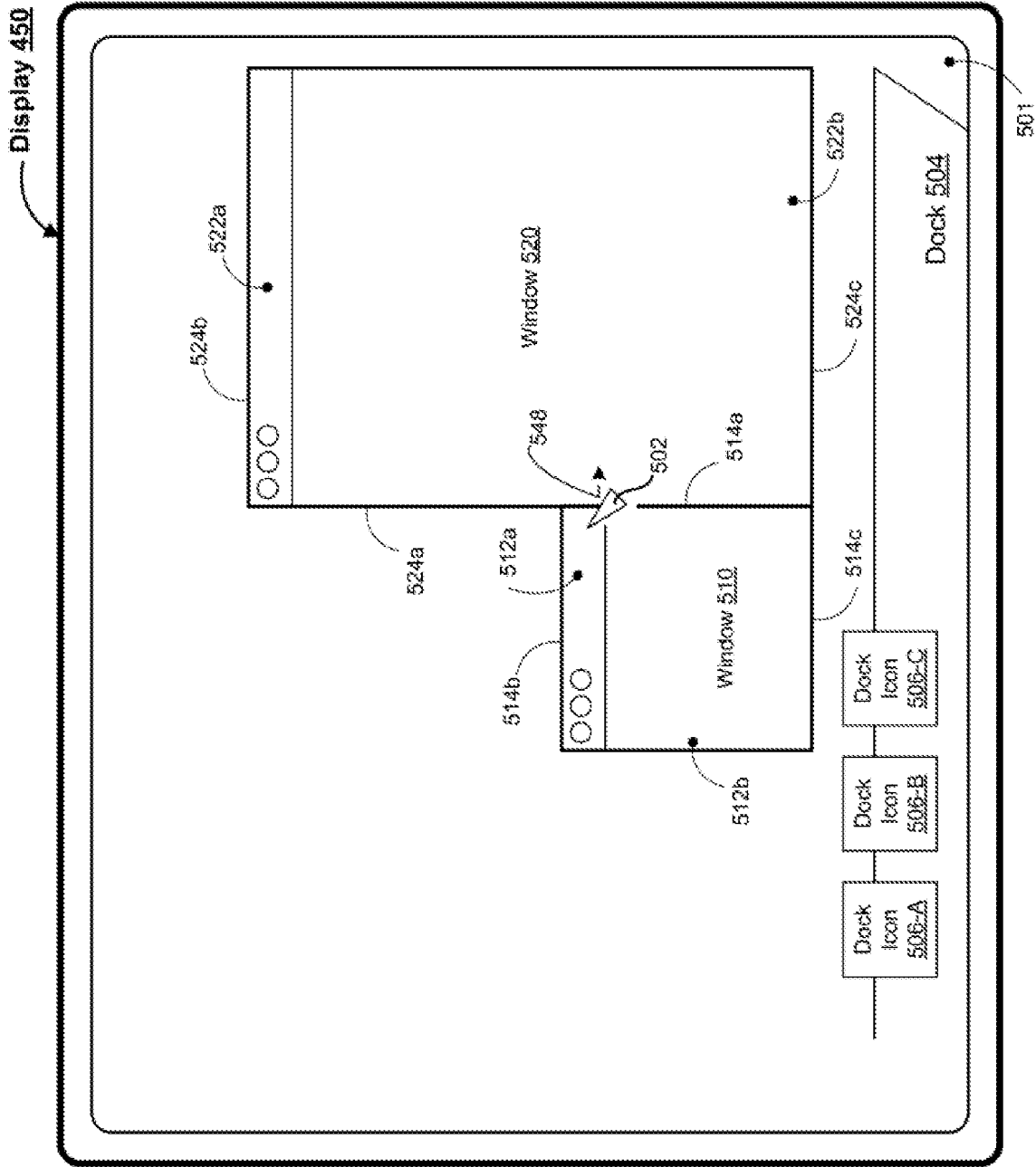

Figure 5R

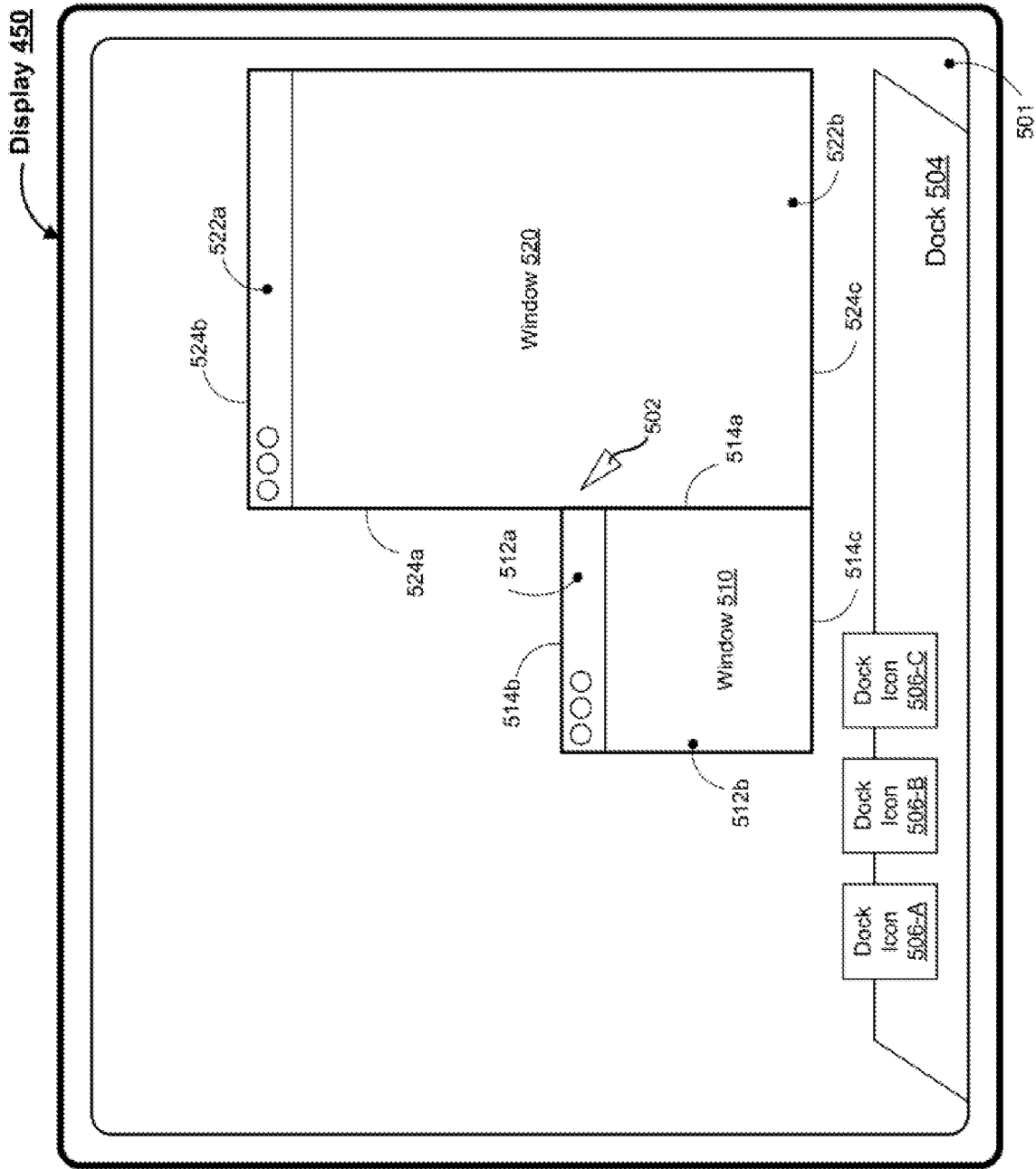

Figure 5S

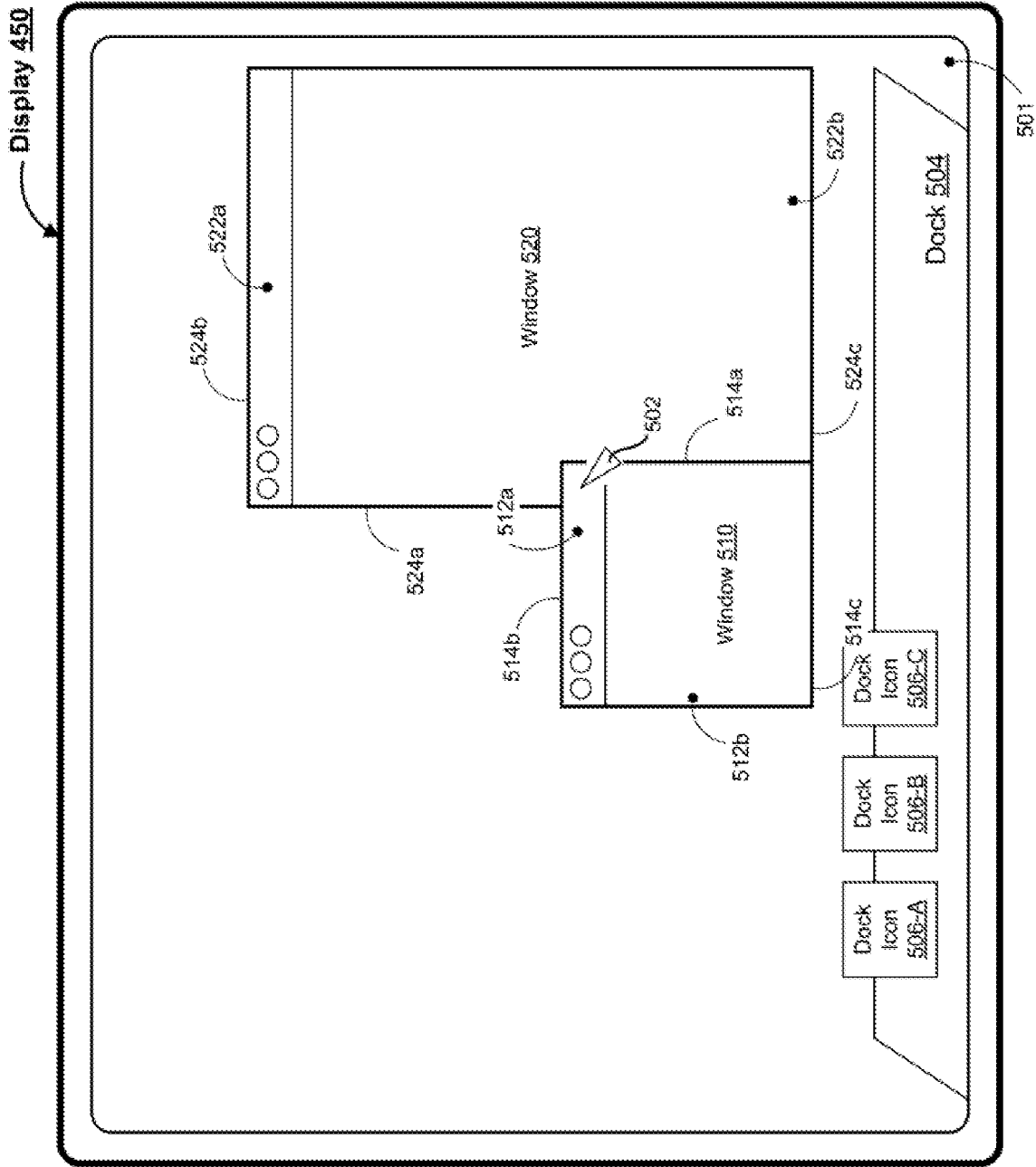

Figure 5T

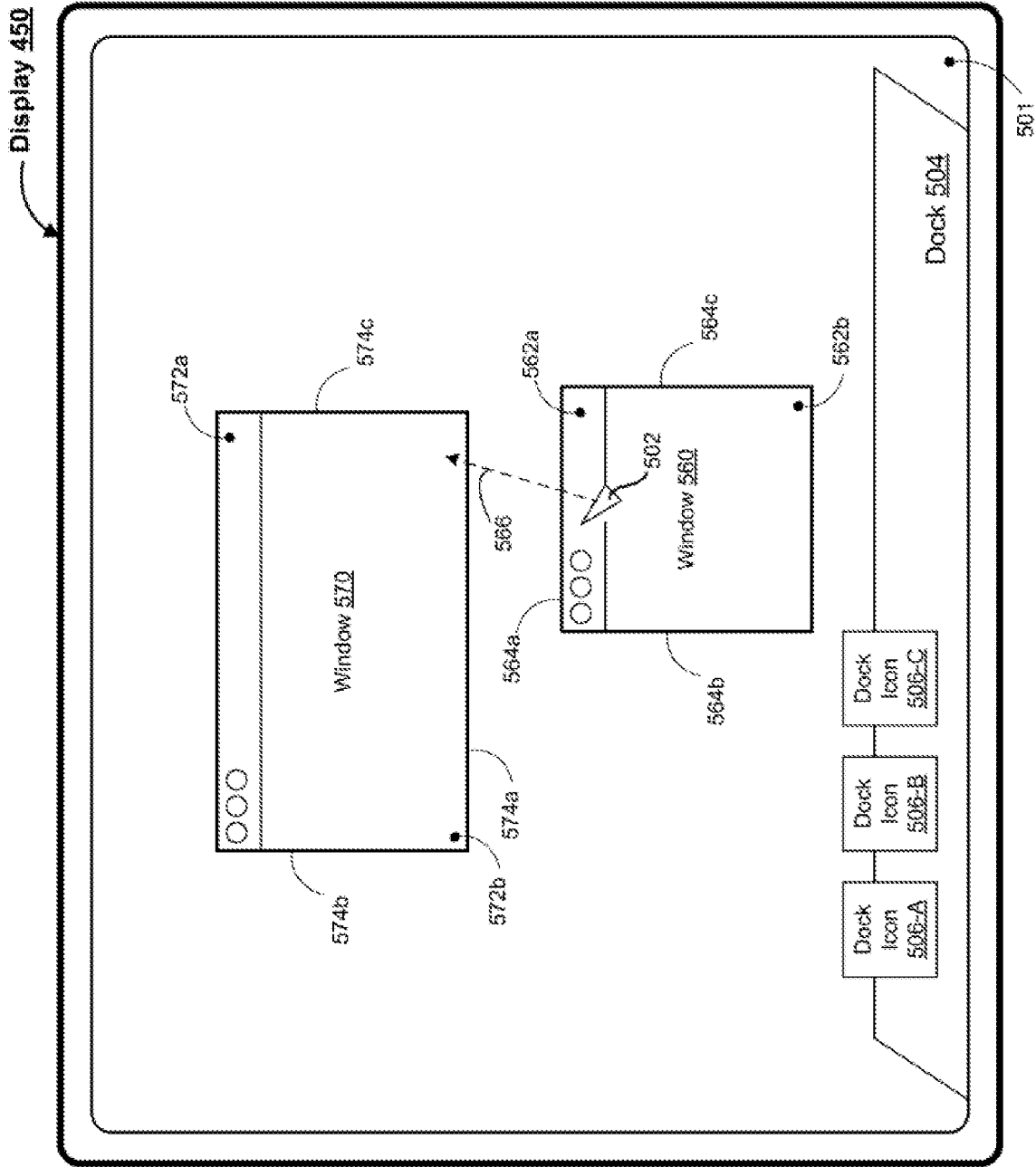
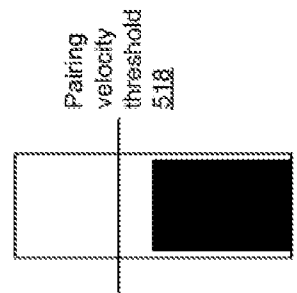
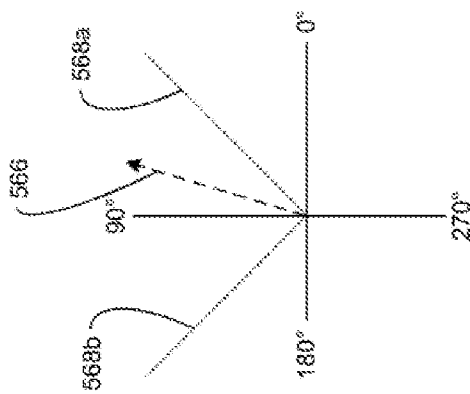

Figure 5U



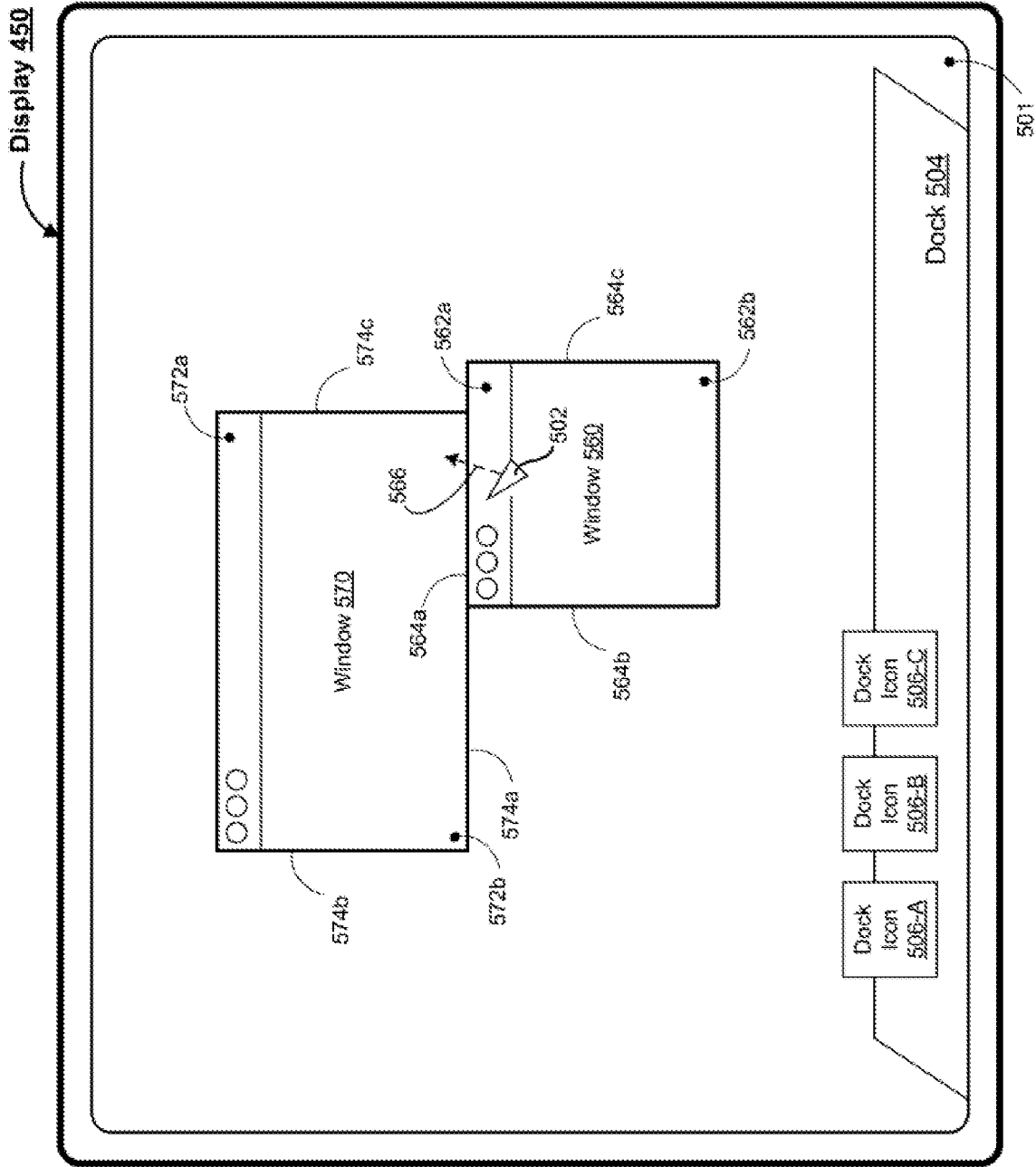

Figure 5V

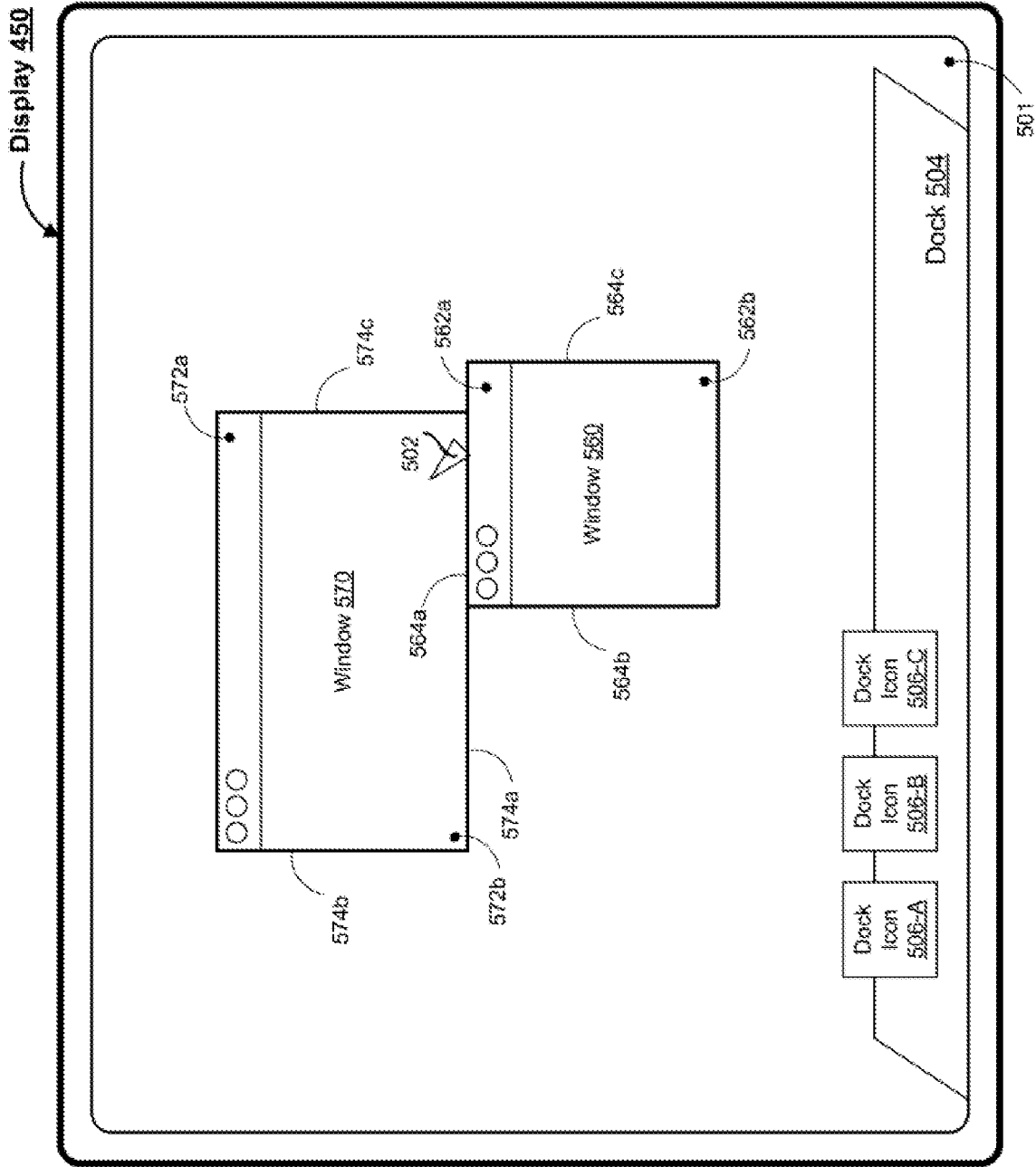

Figure 5W

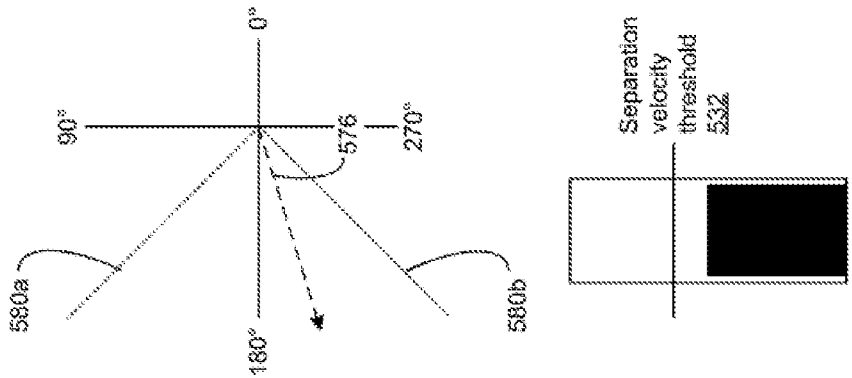
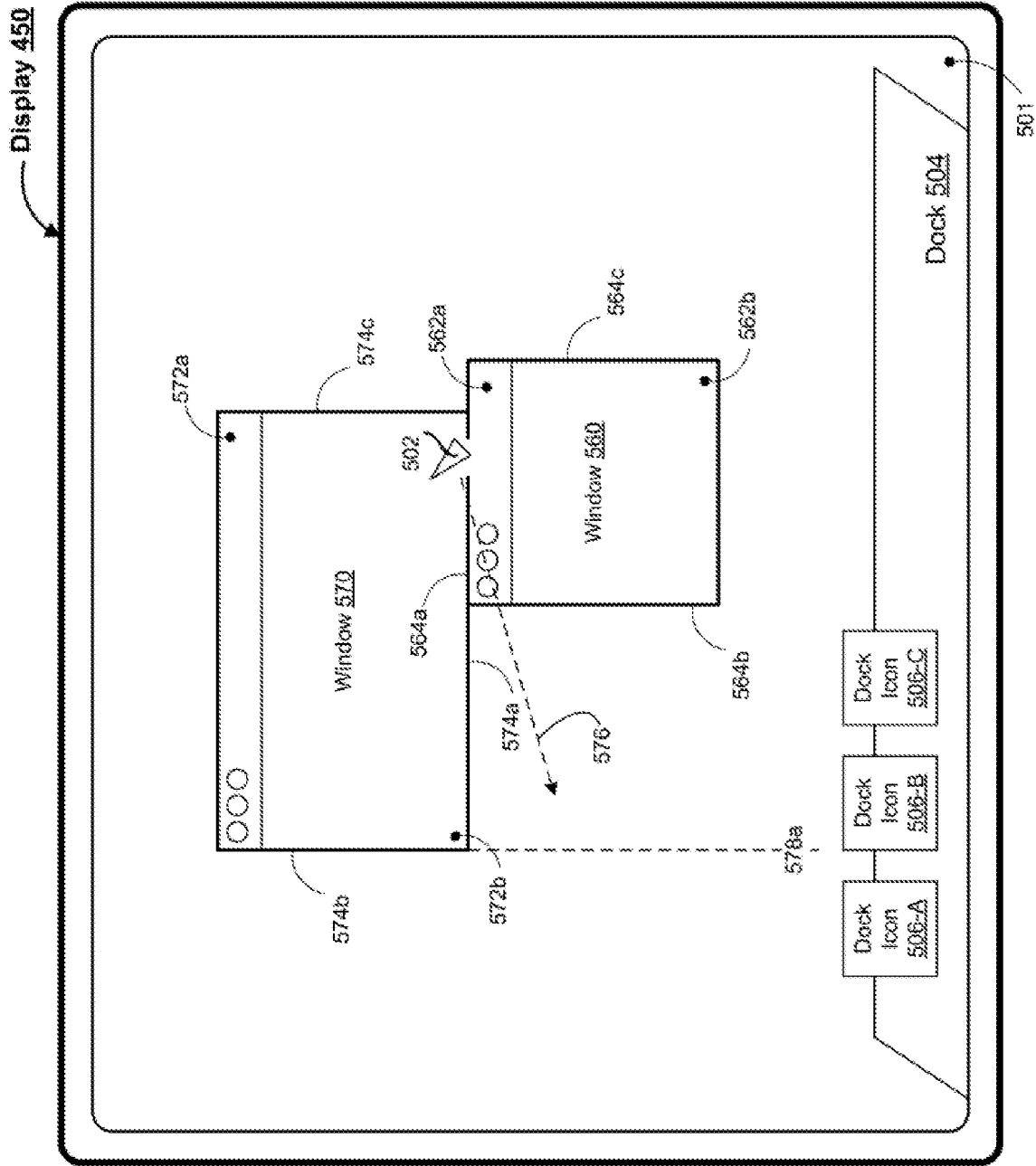

Figure 5X



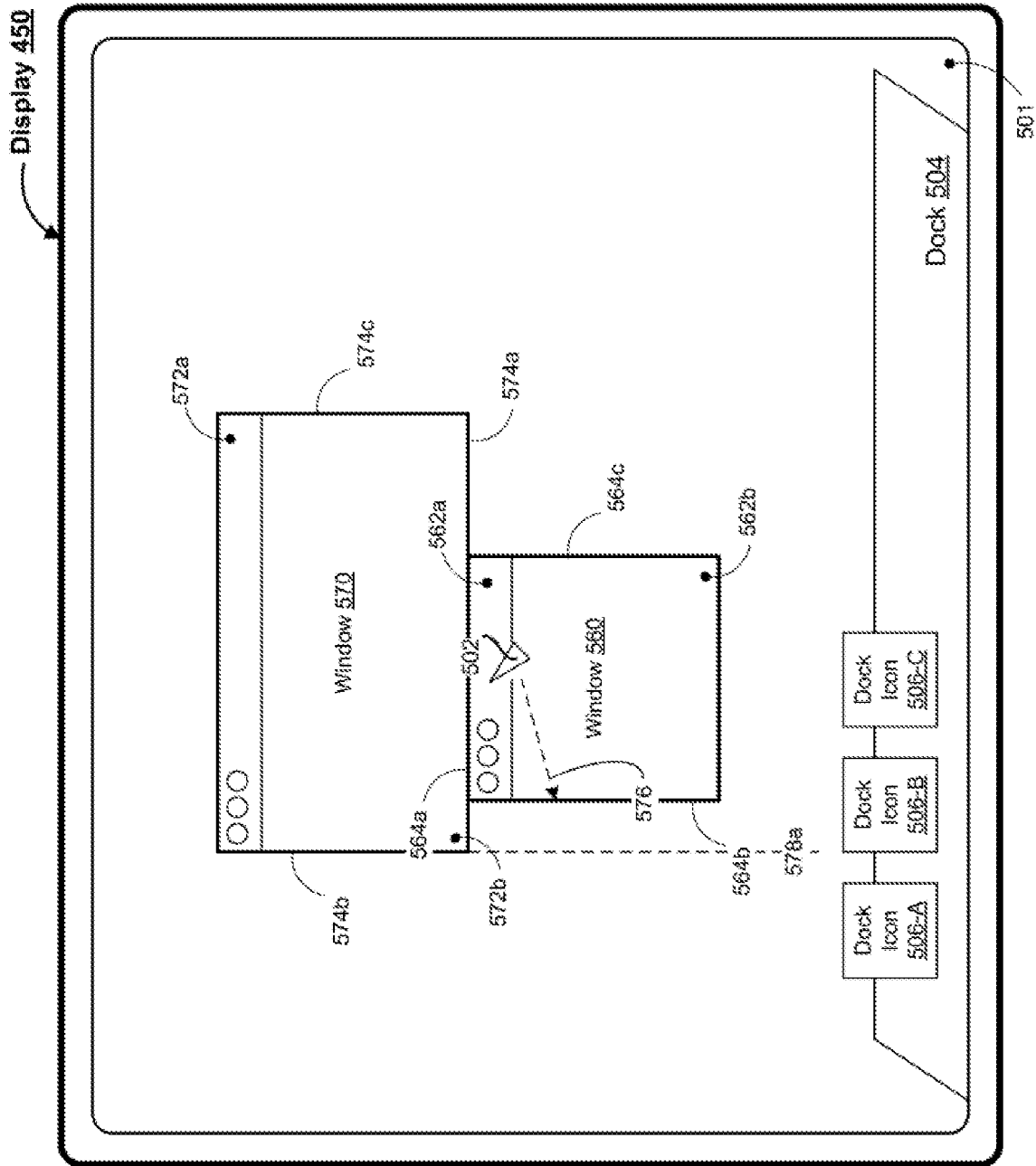

Figure 5Y

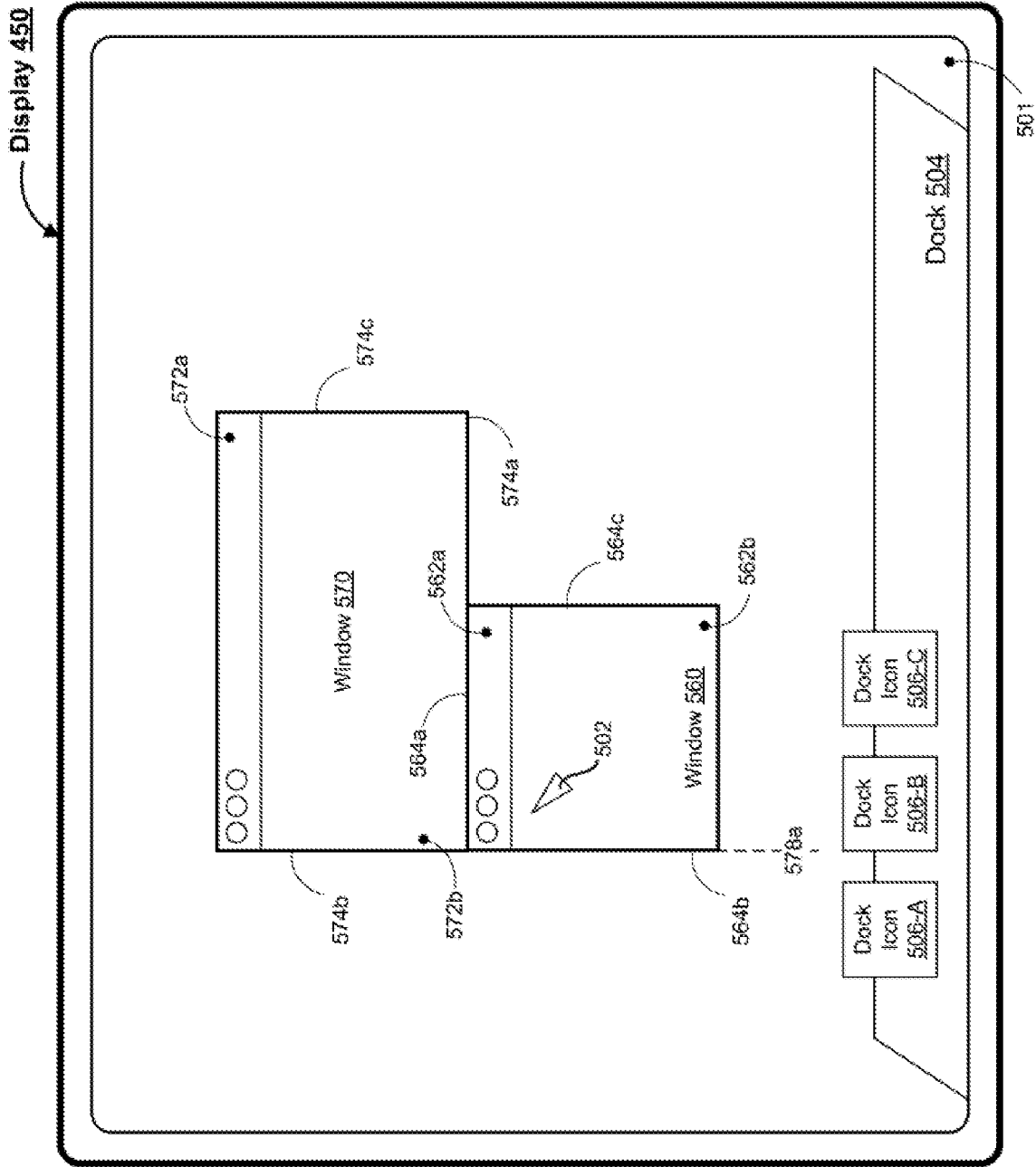

Figure 5Z

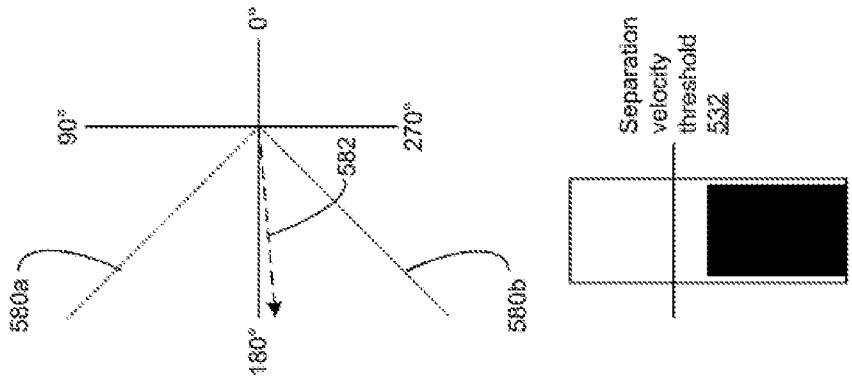
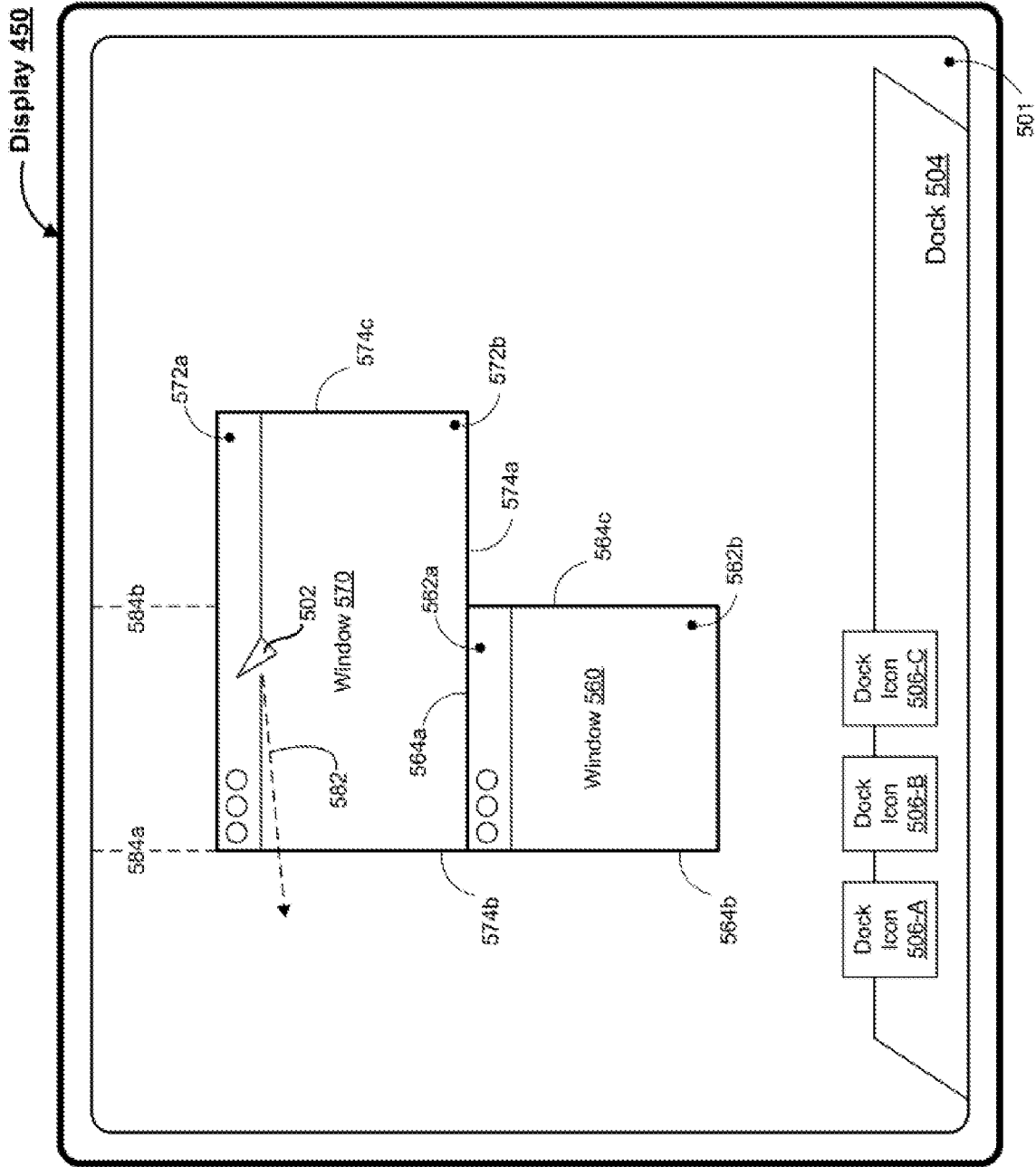

Figure 5AA

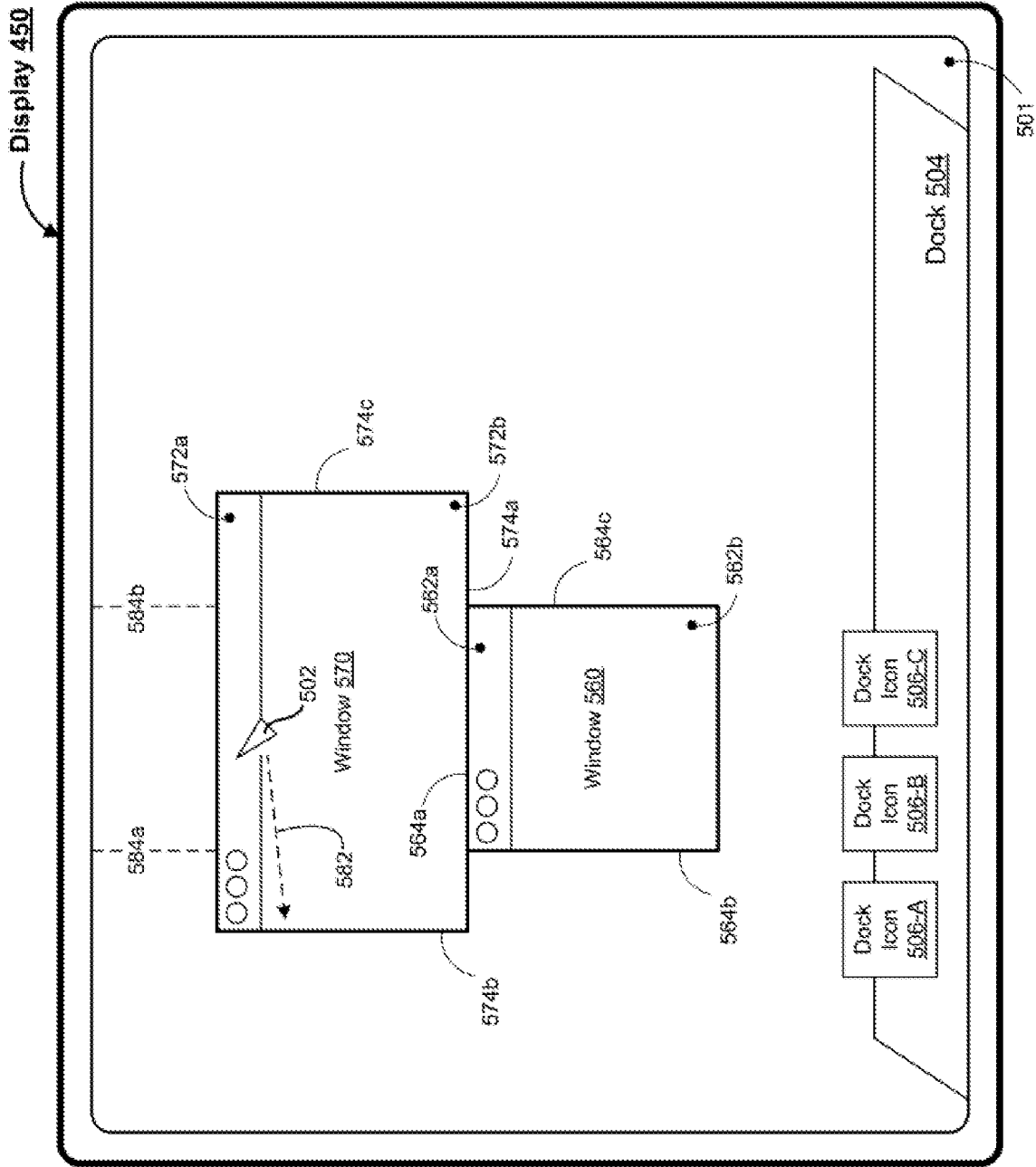

Figure 5BB

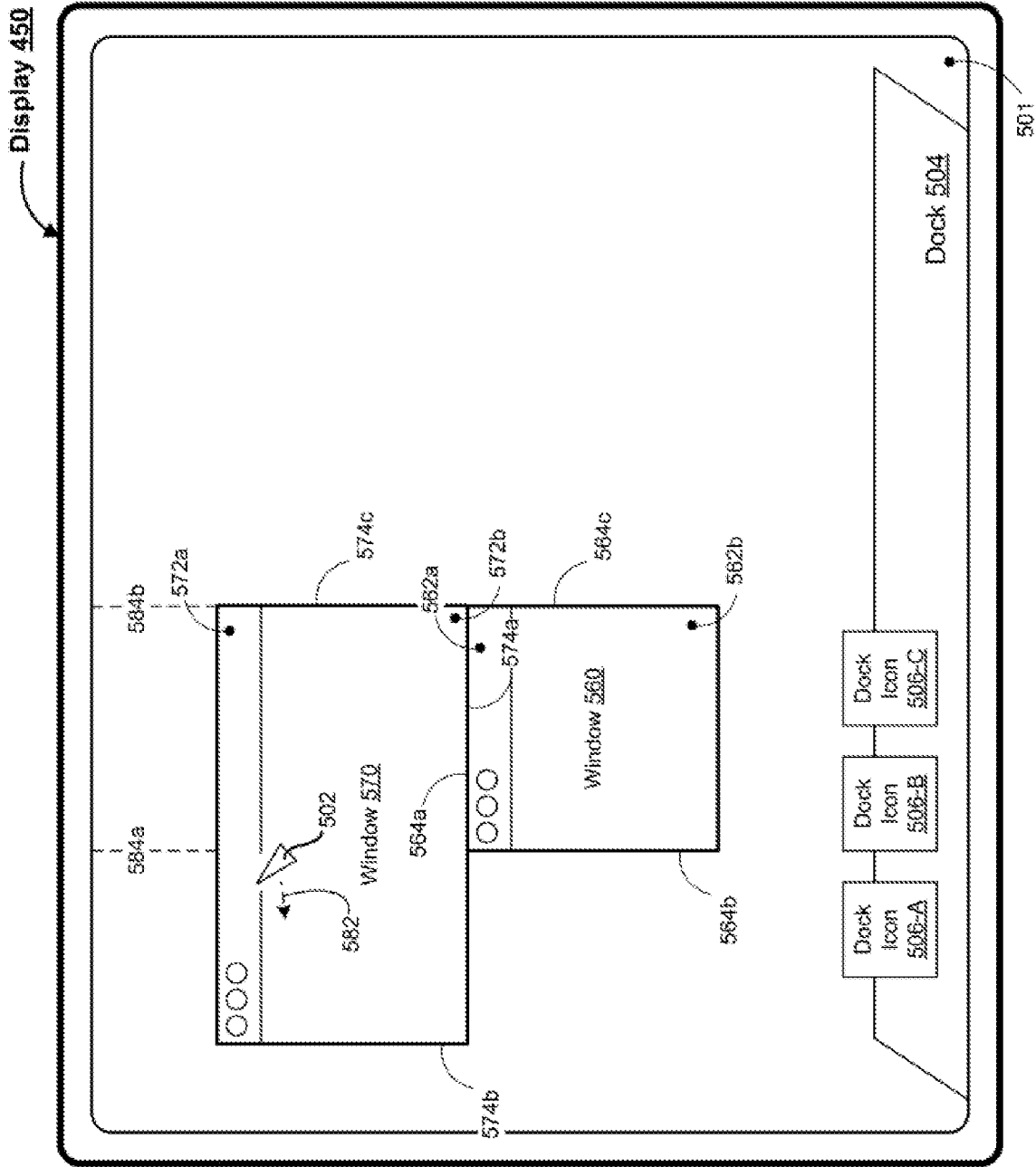

Figure 5CC

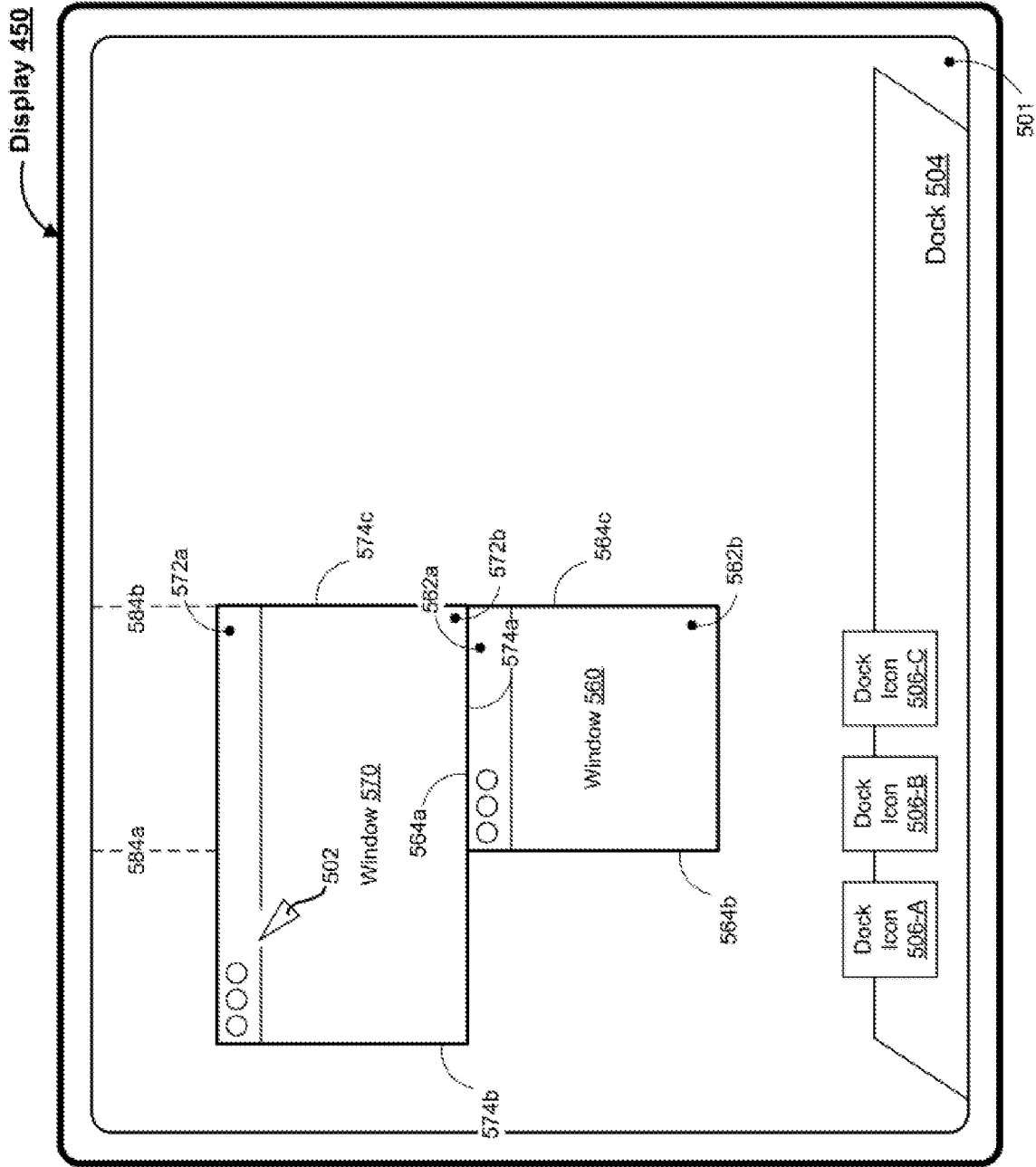

Figure 5DD

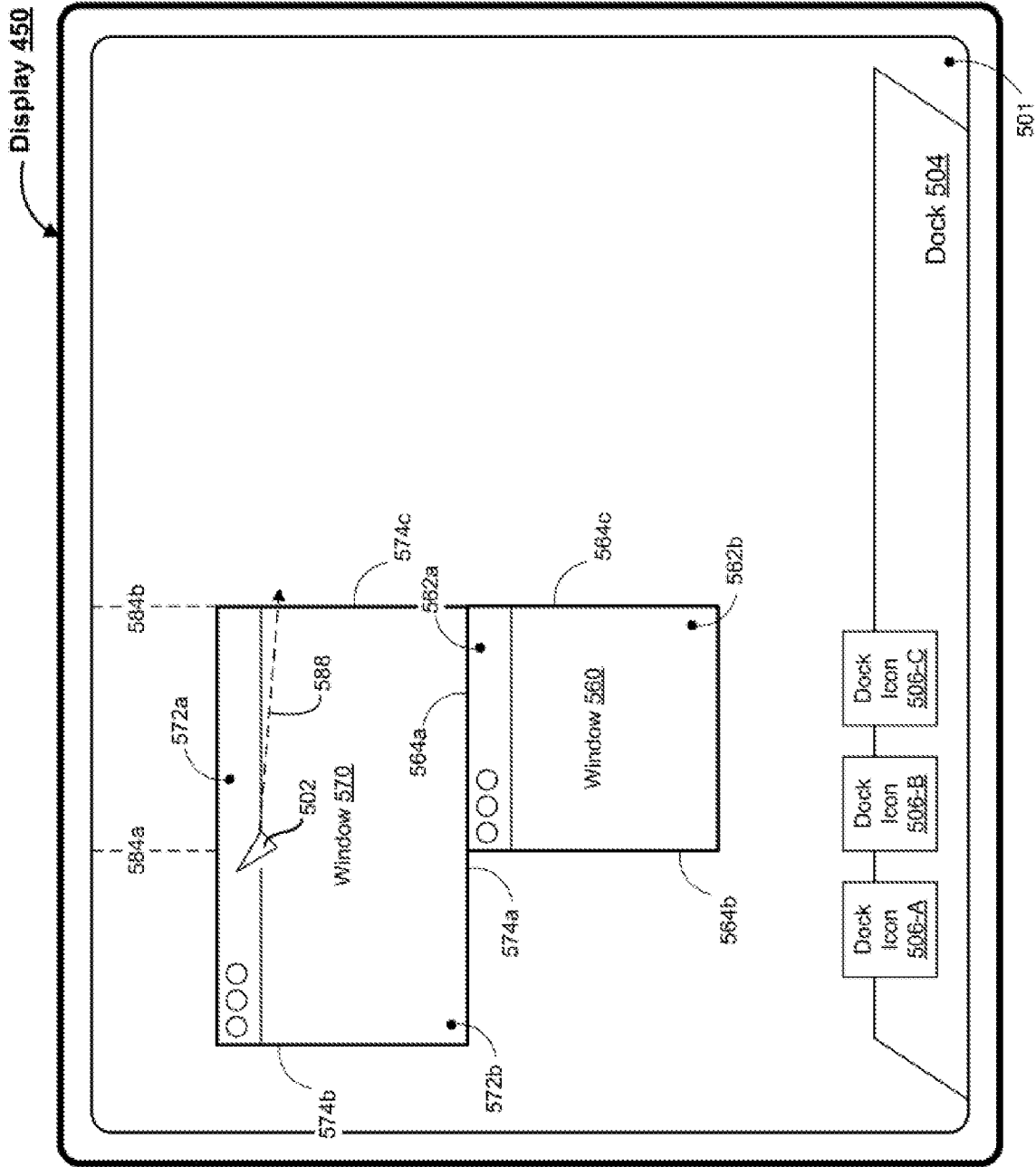
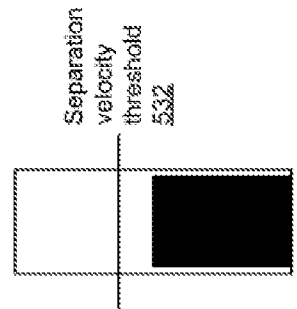
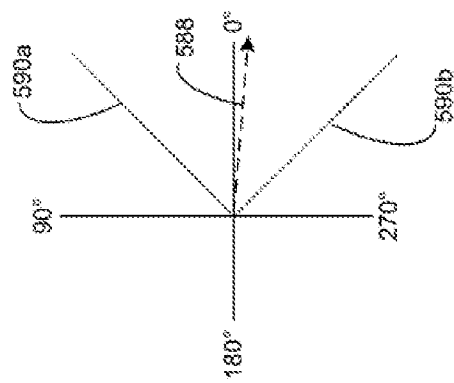

Figure 5EE



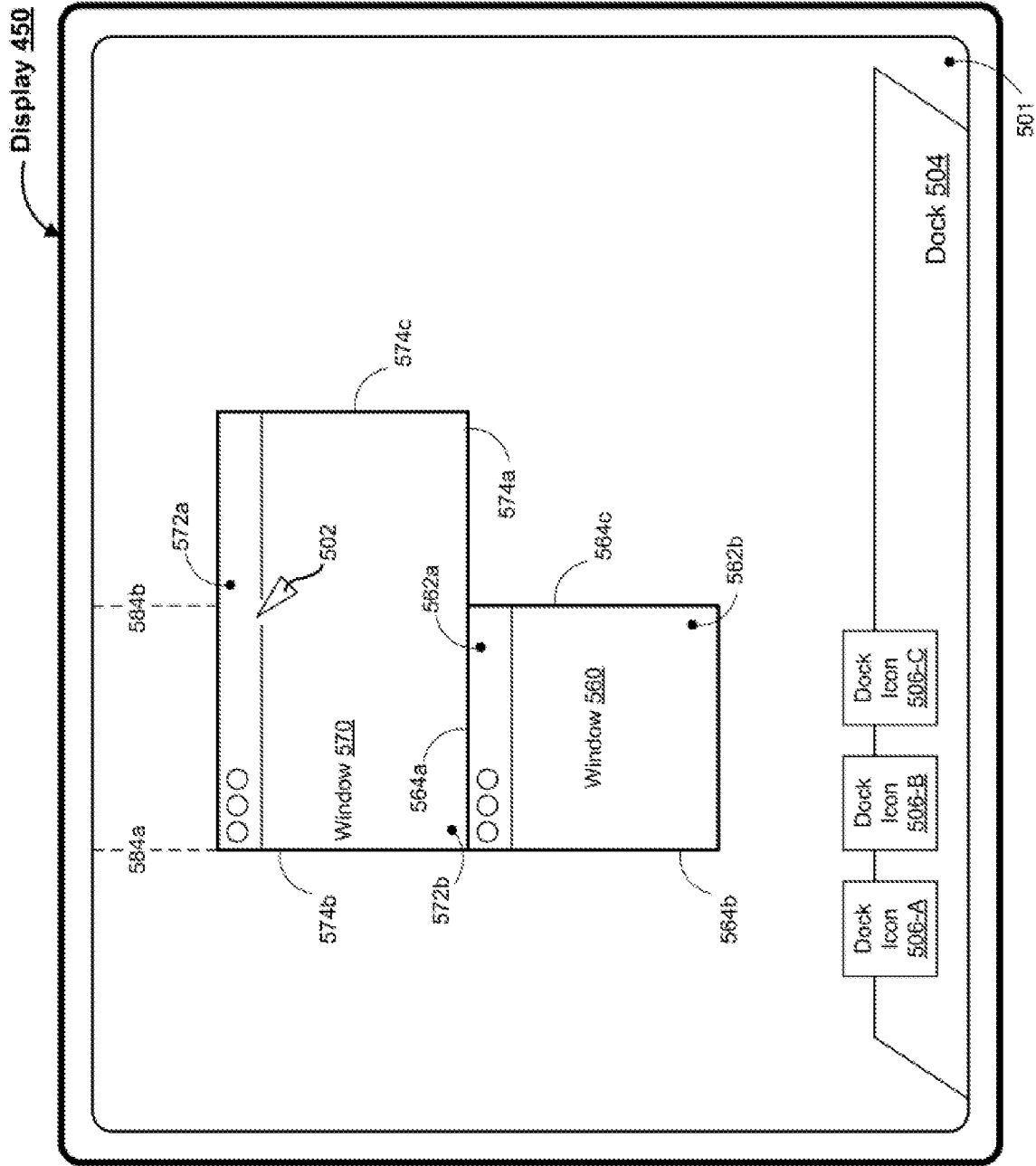

Figure 5FF



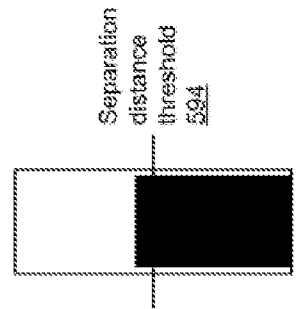
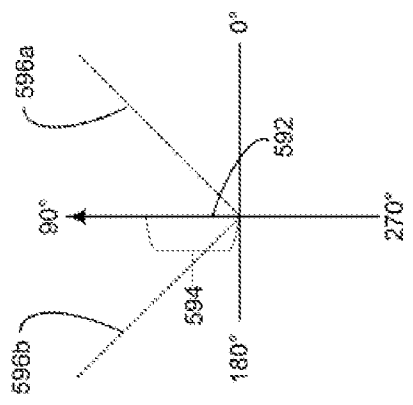
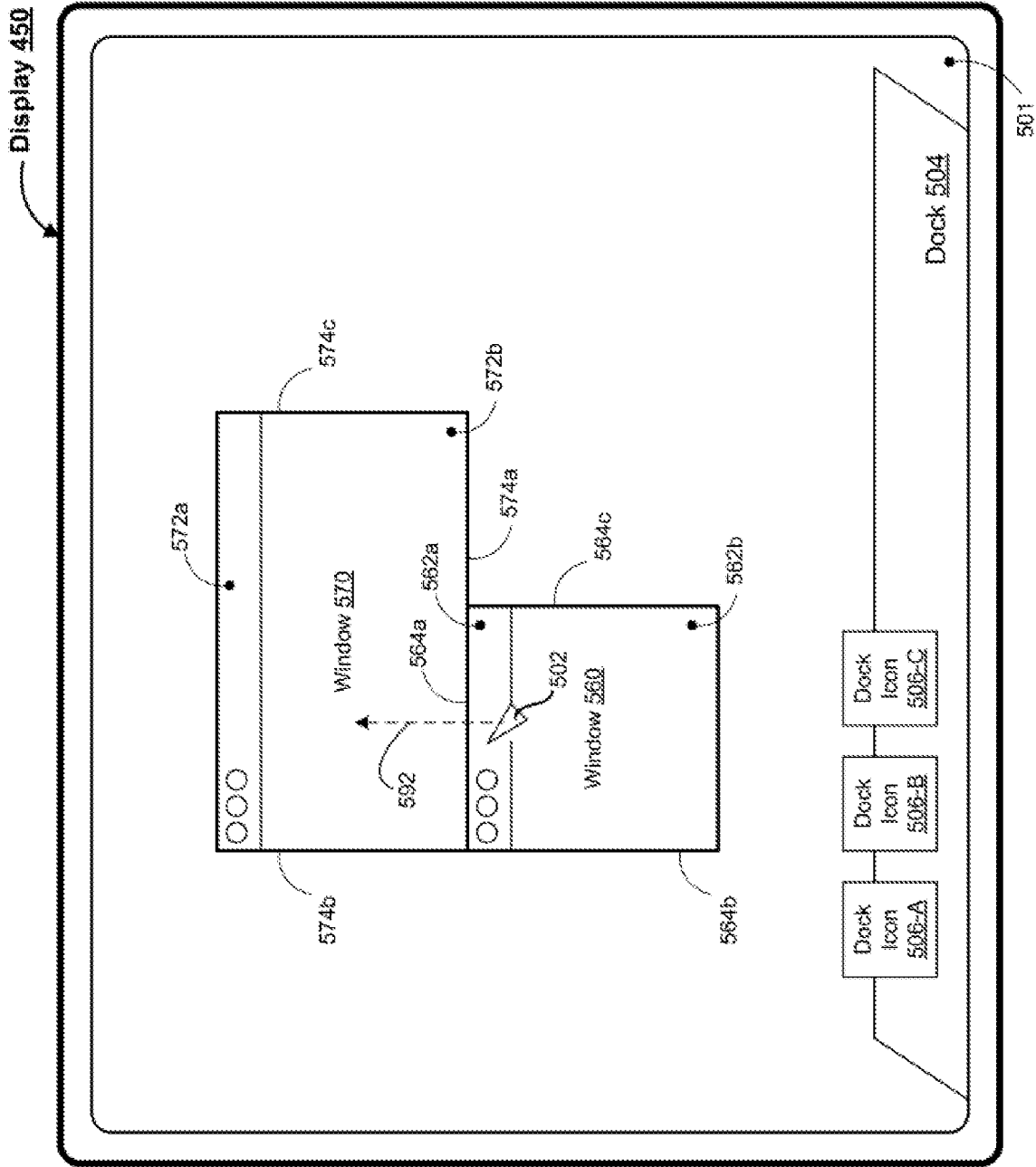

Figure 5GG

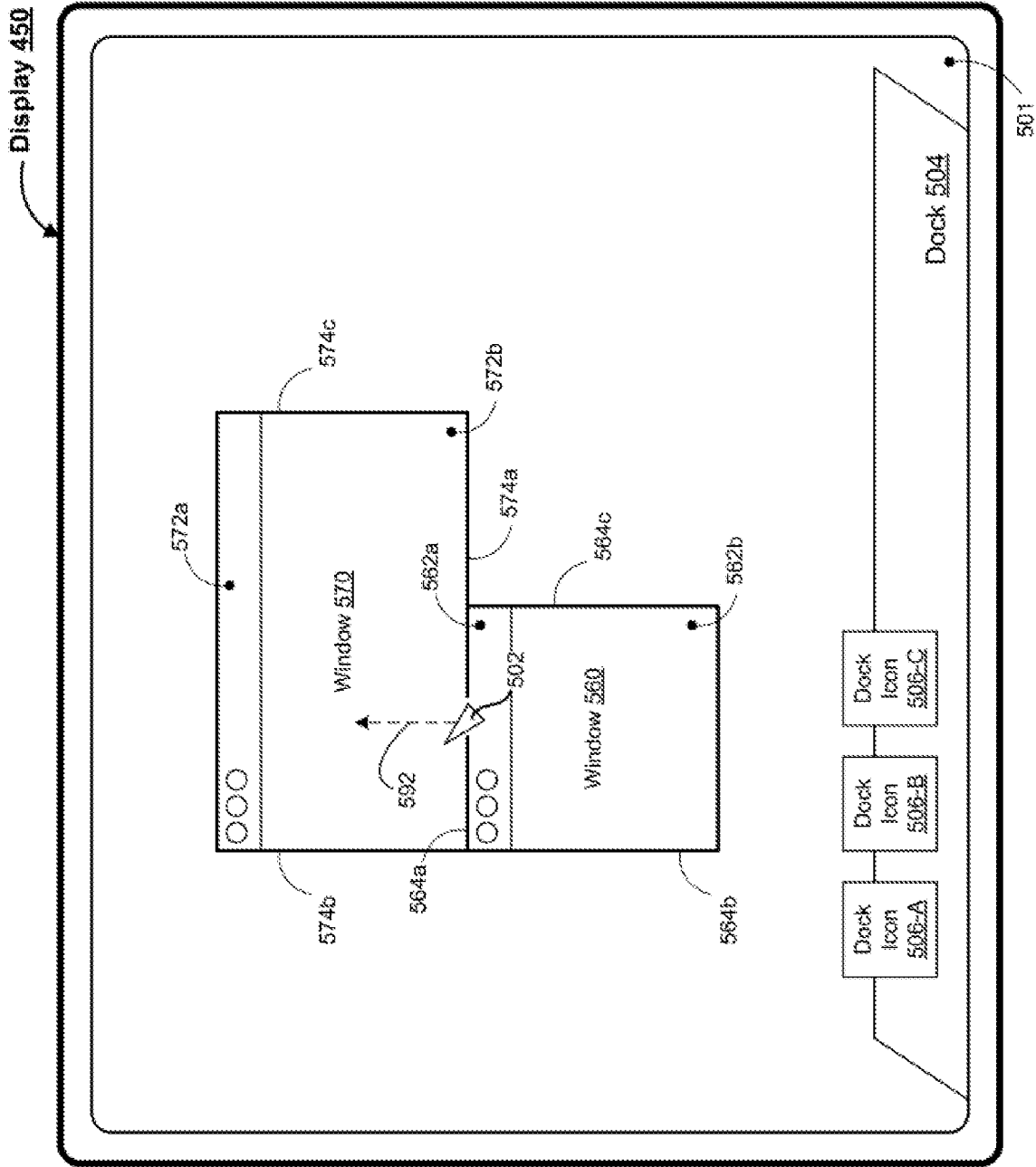

Figure 5HH

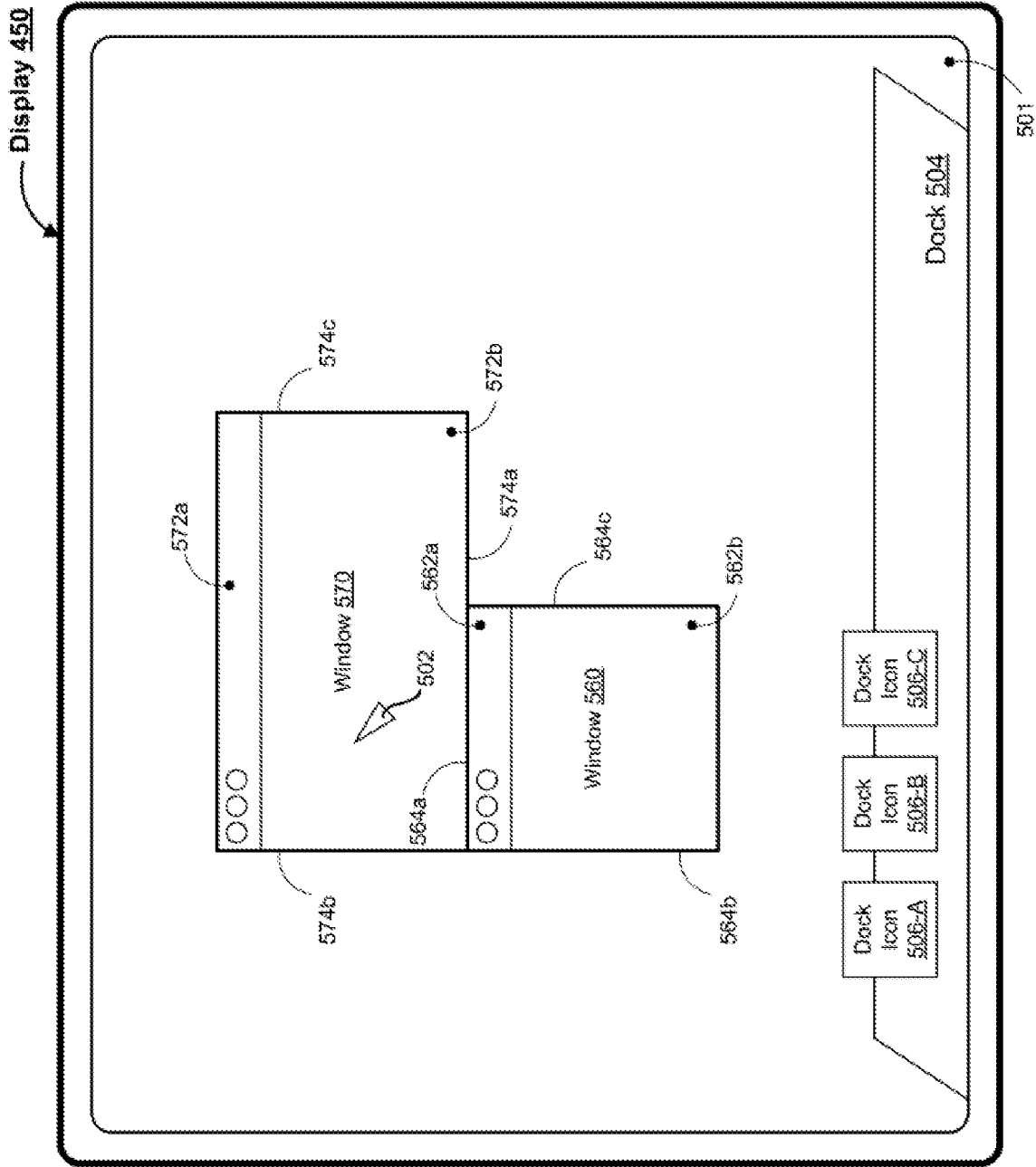

Figure 5II

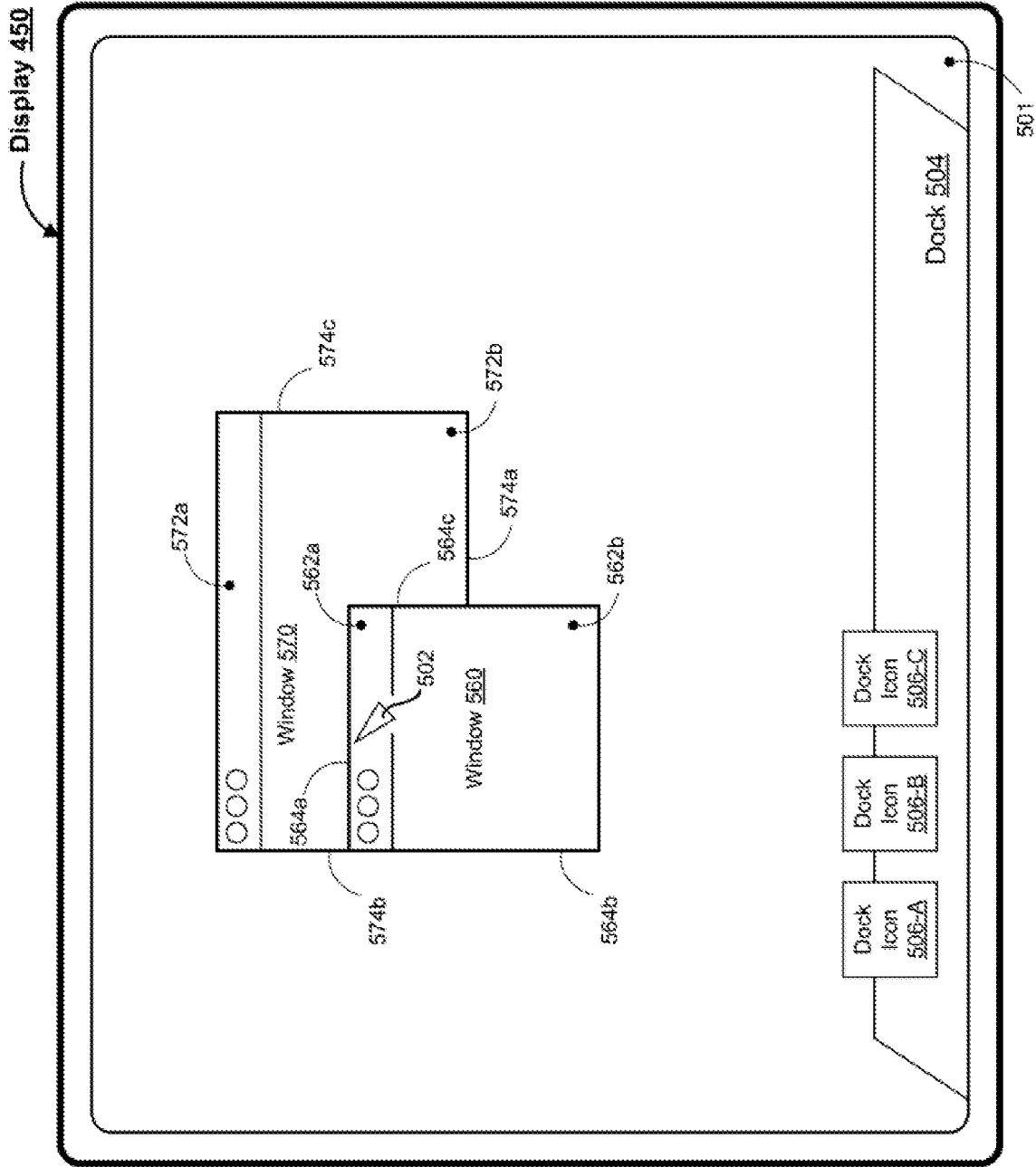

Figure 5JJ

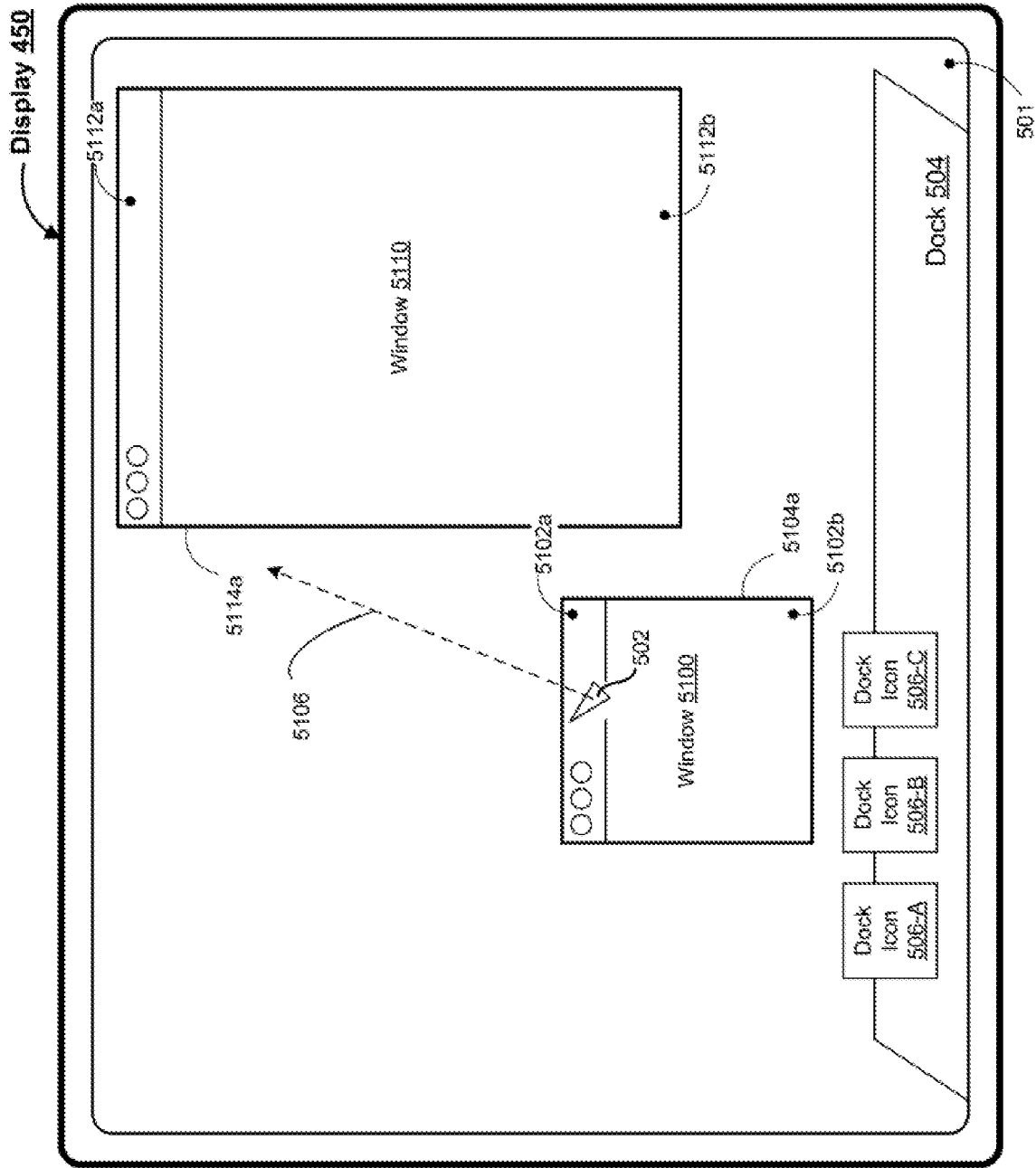
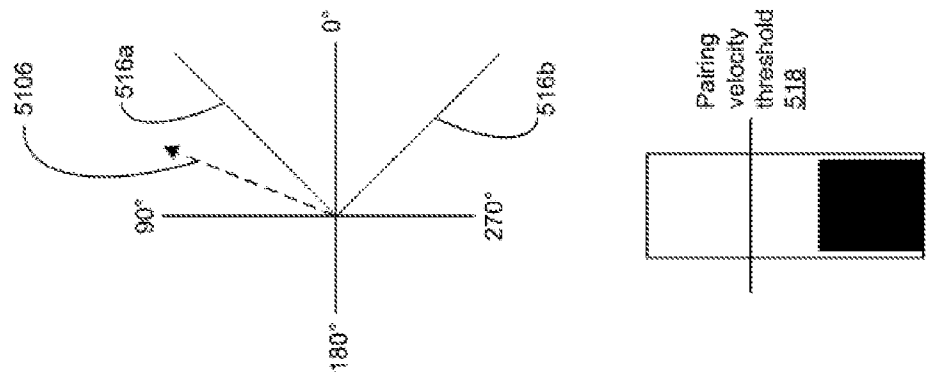

Figure 5KK



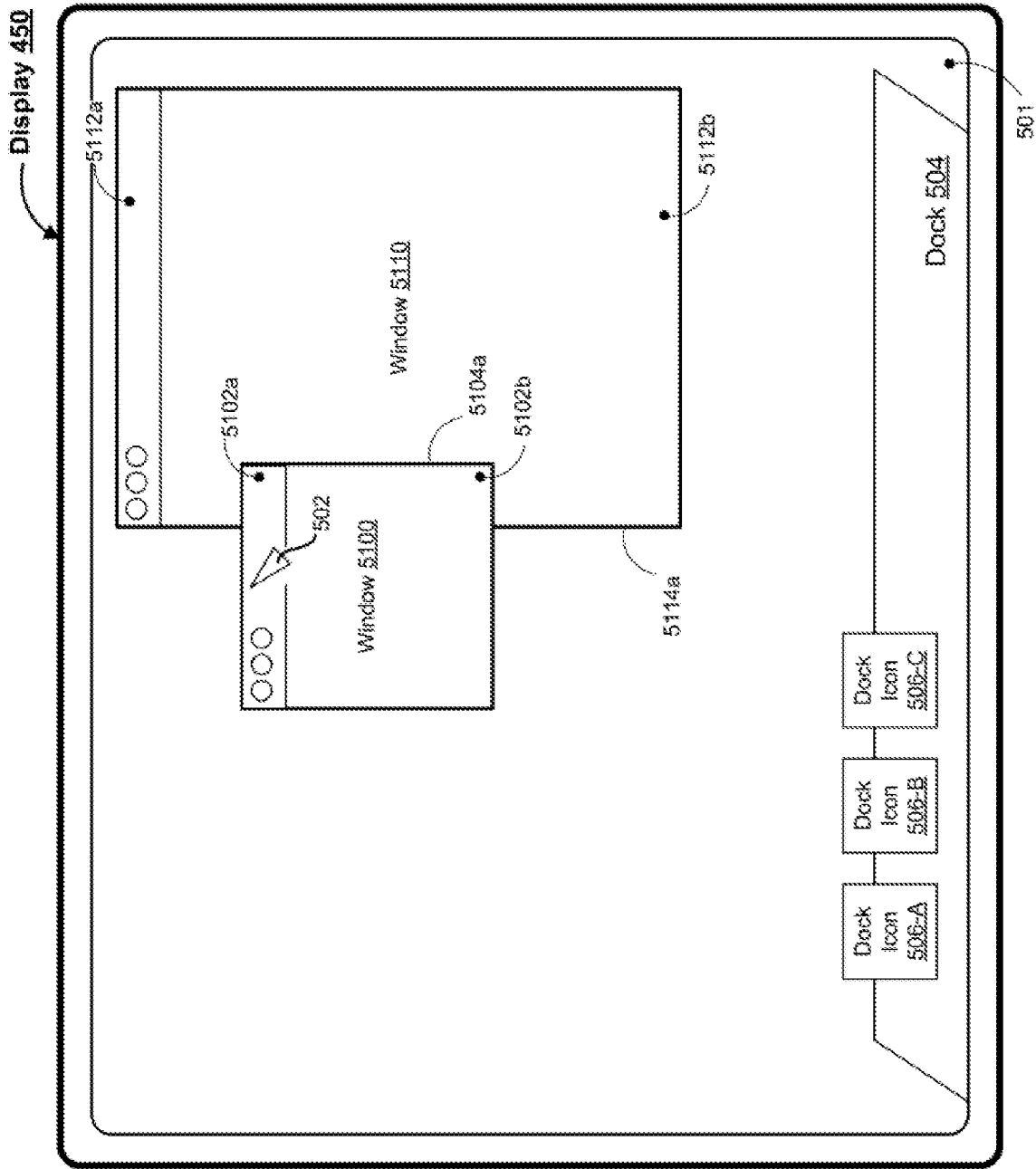

Figure 5LL

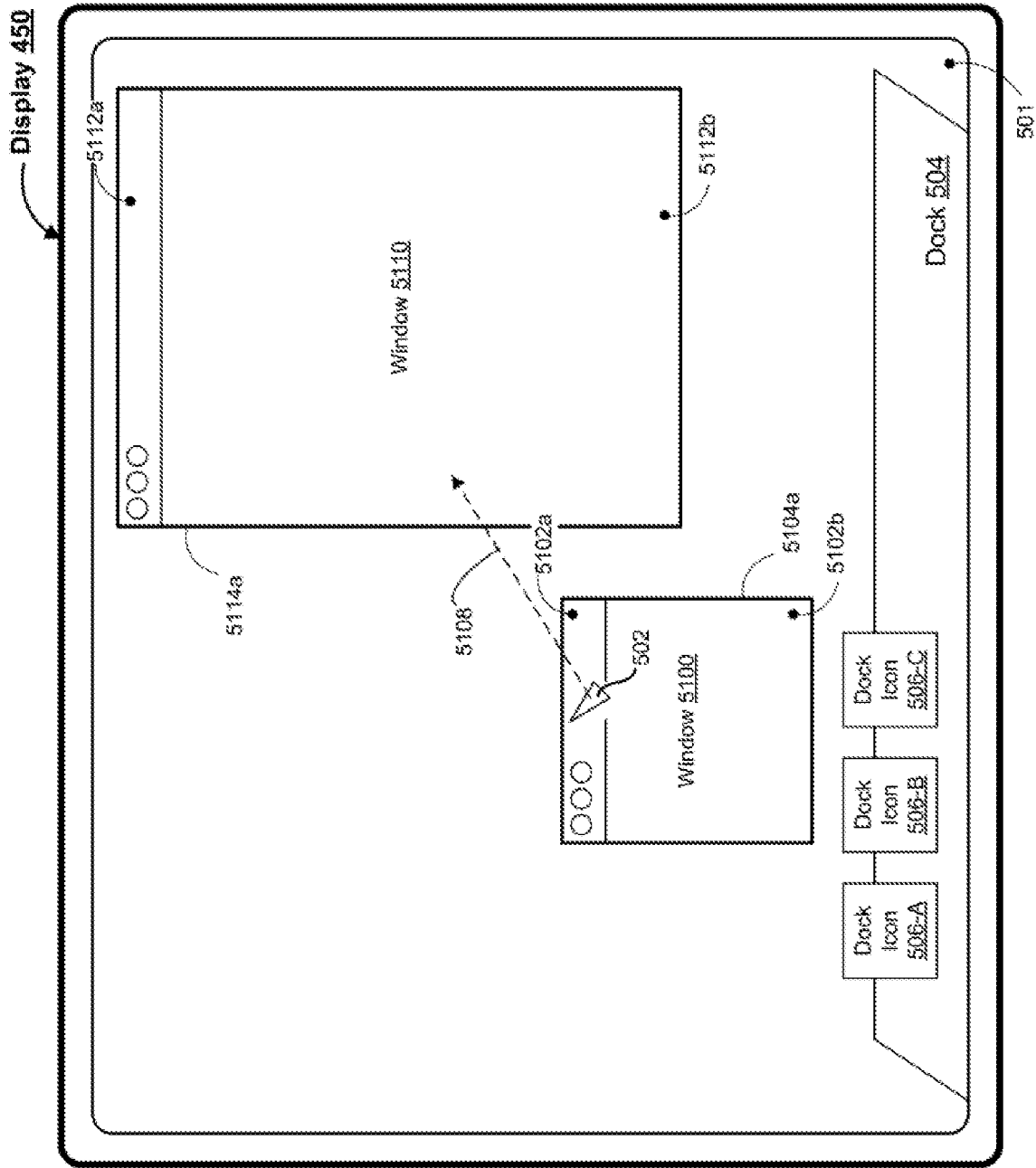

Figure 5MM

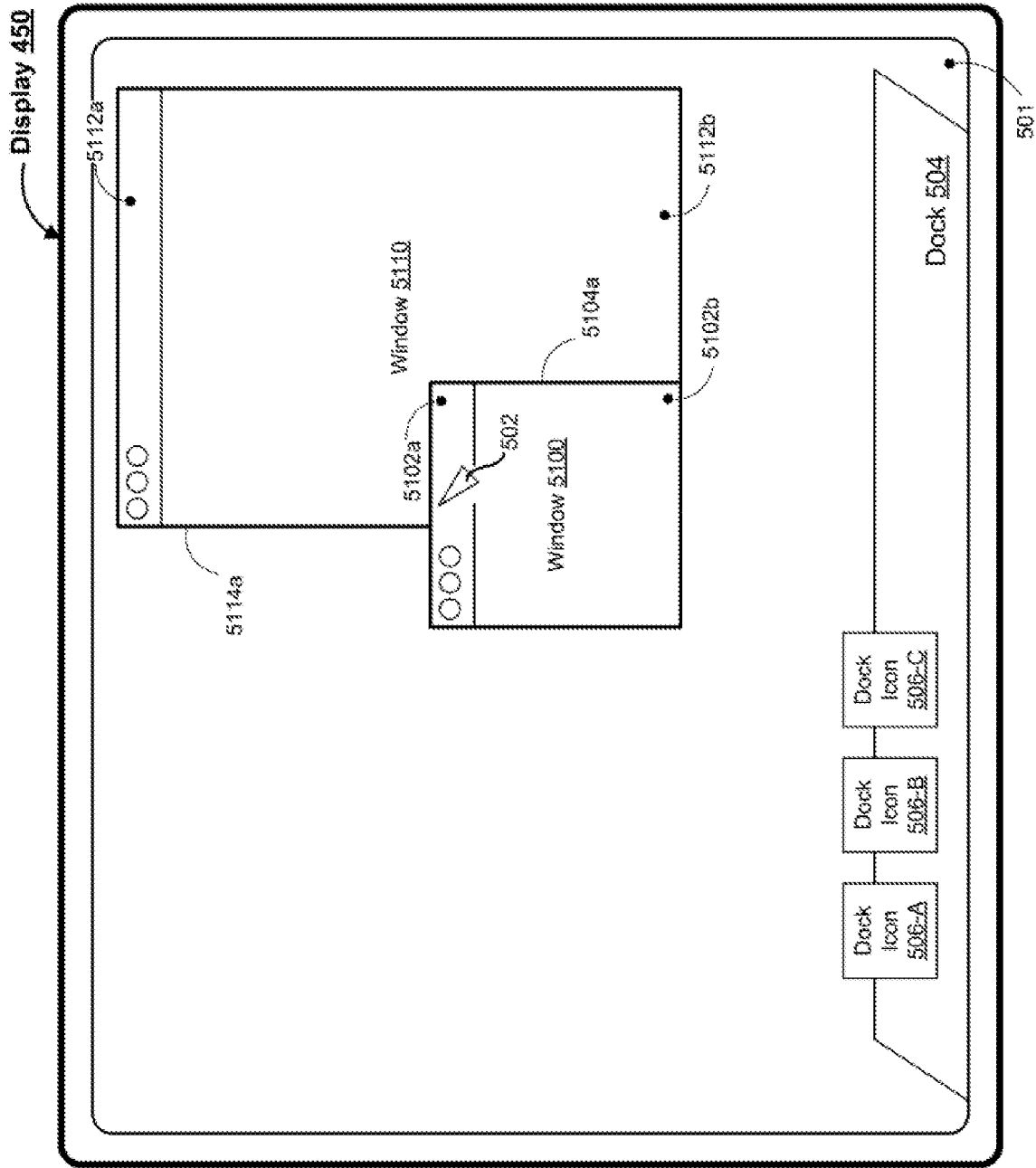

Figure 5NN



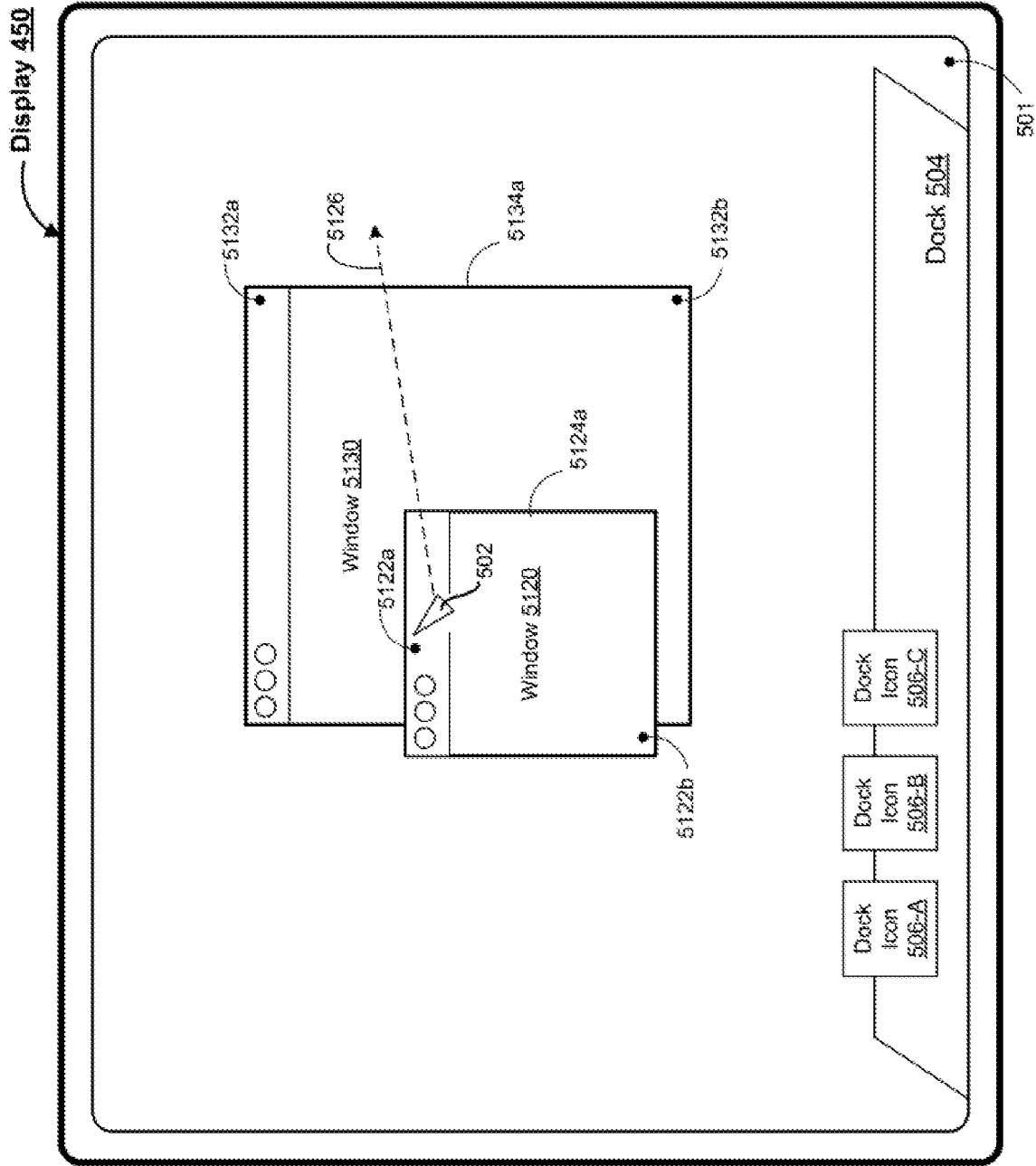

Figure 500

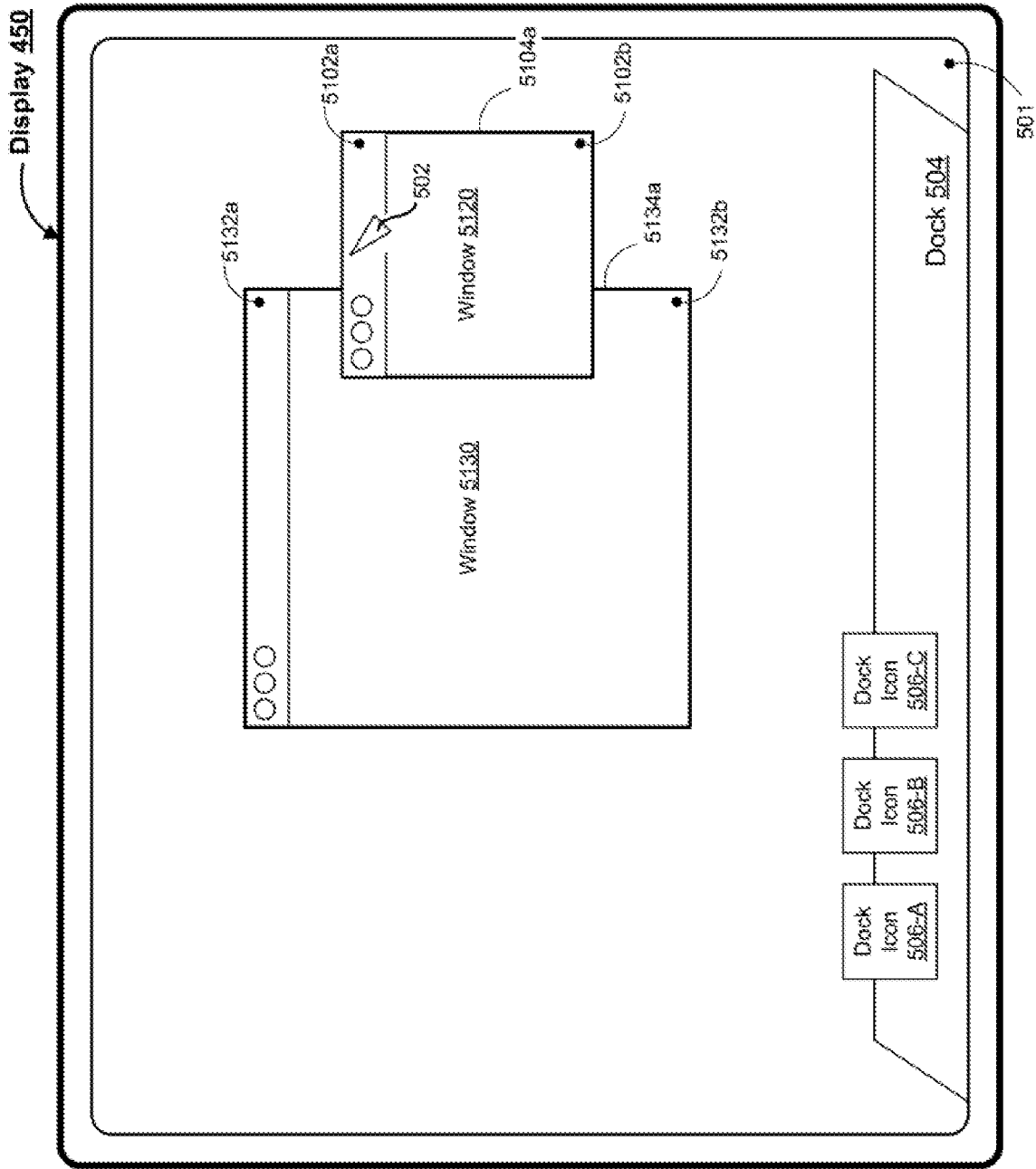

Figure 5PP

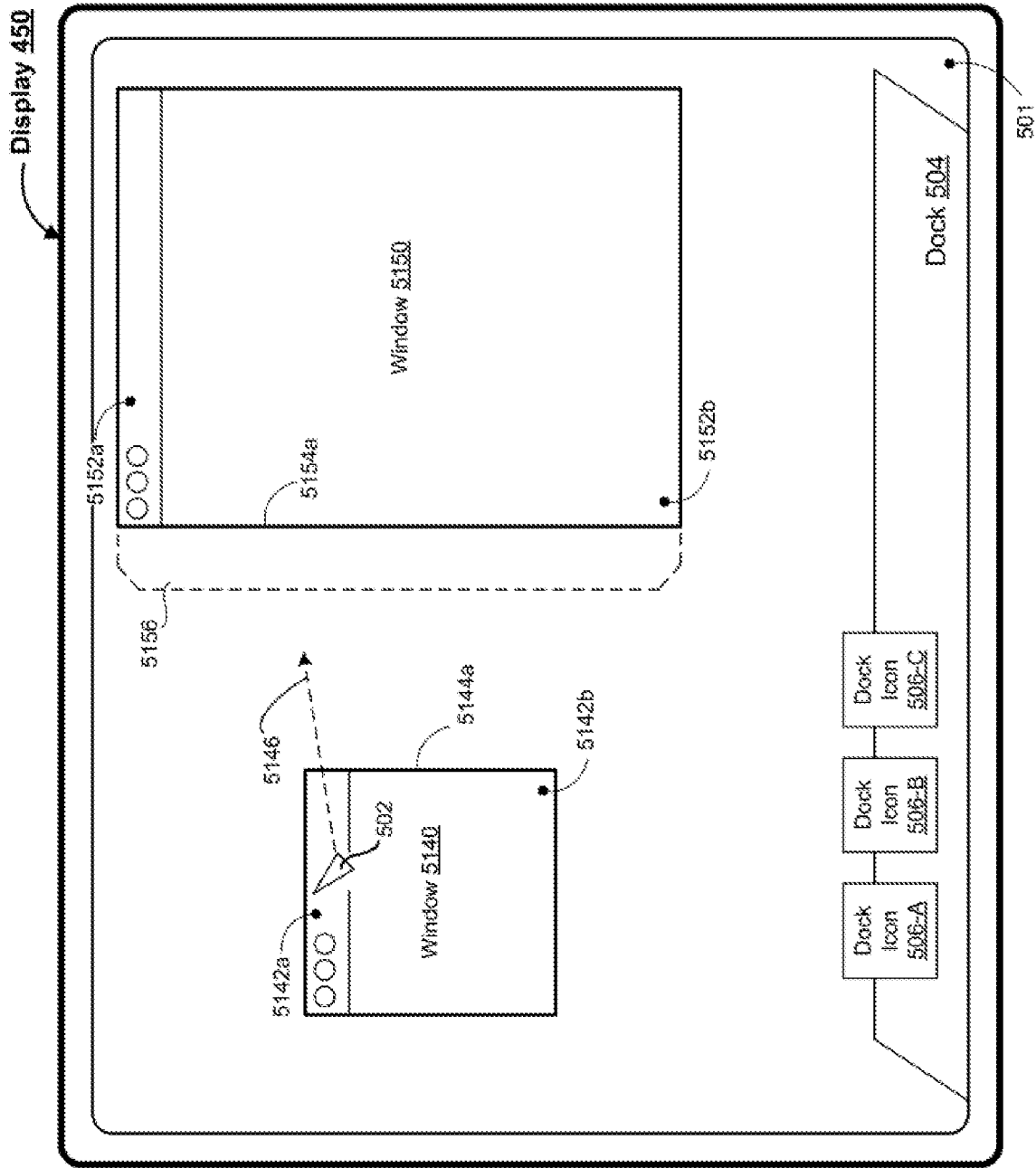

Figure 50Q

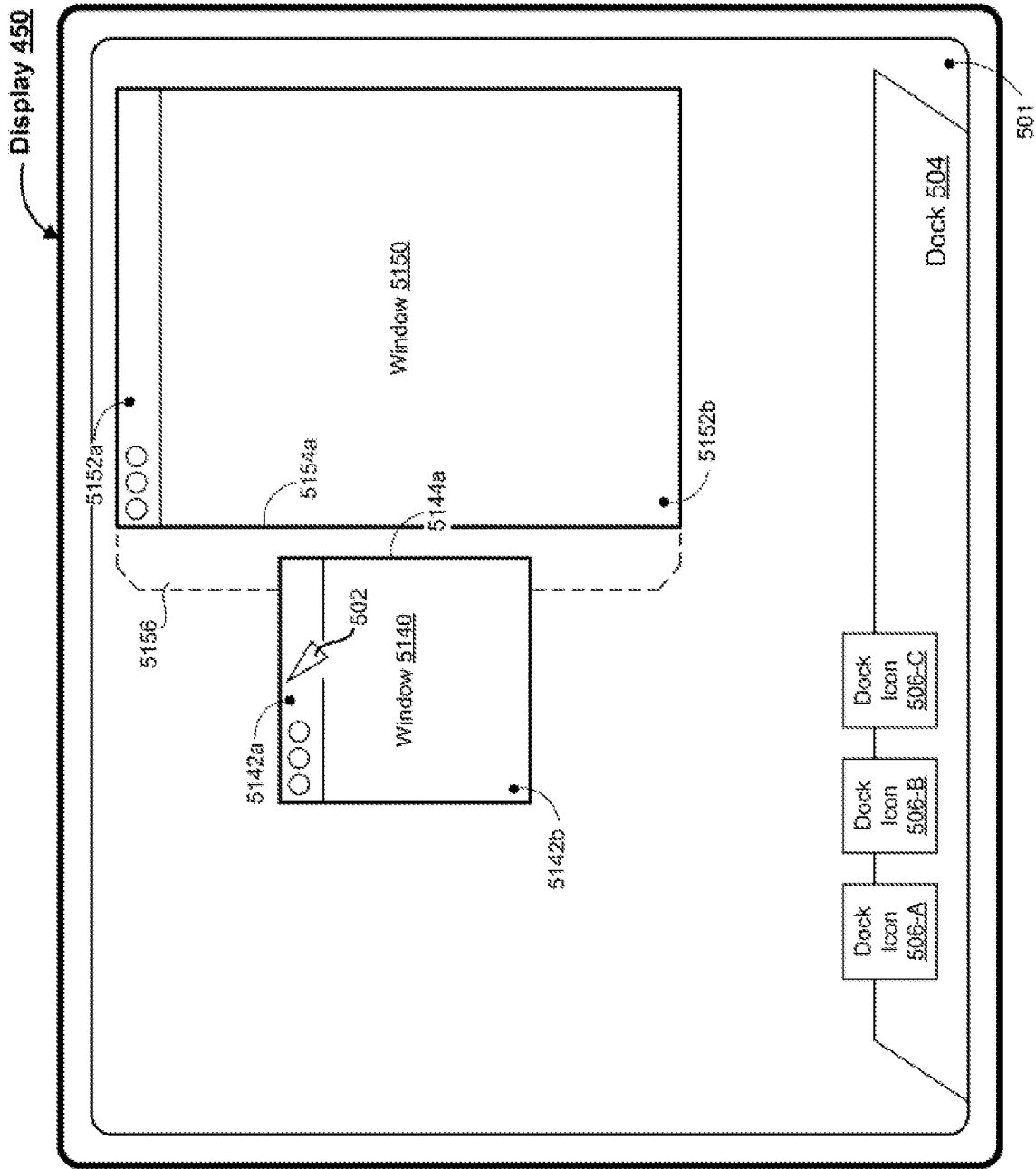

Figure 5RR

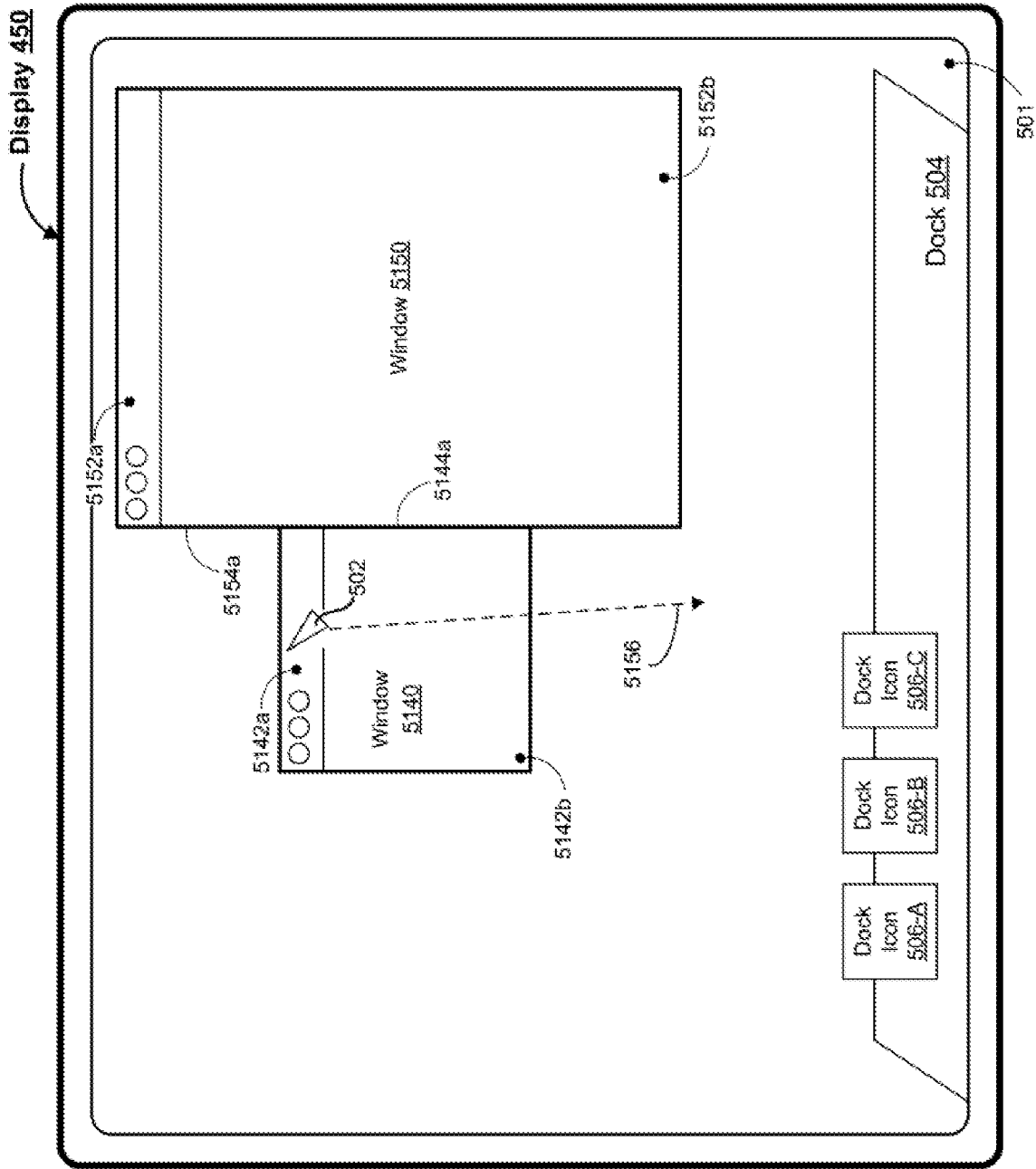

Figure 5SS

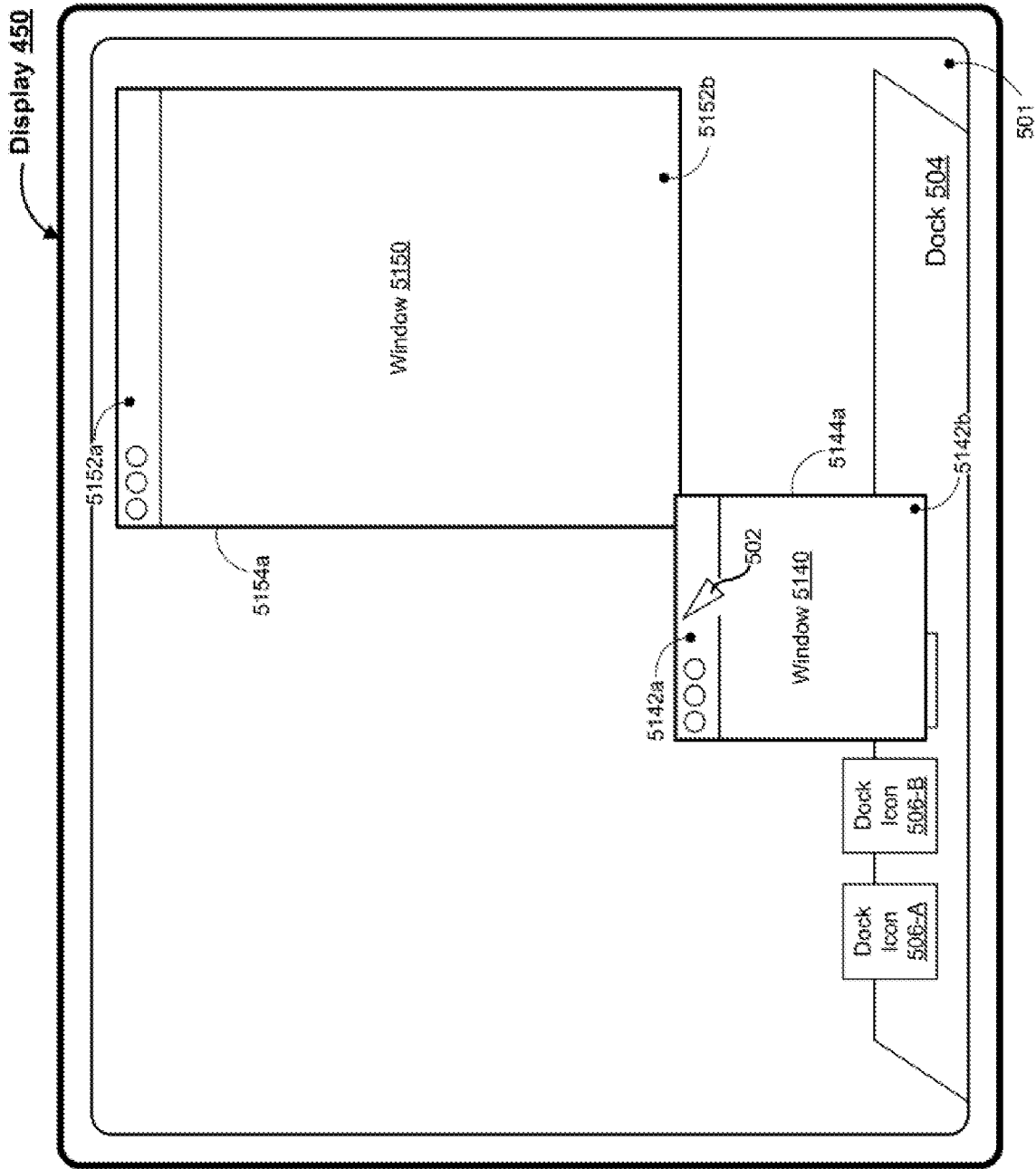

Figure 5TT

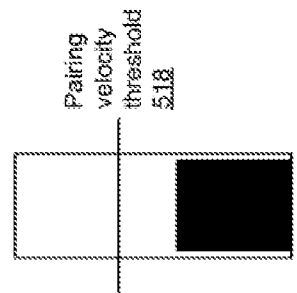
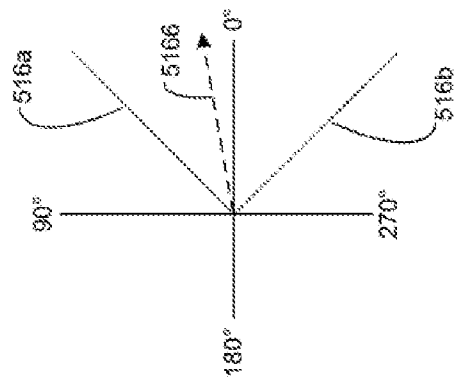
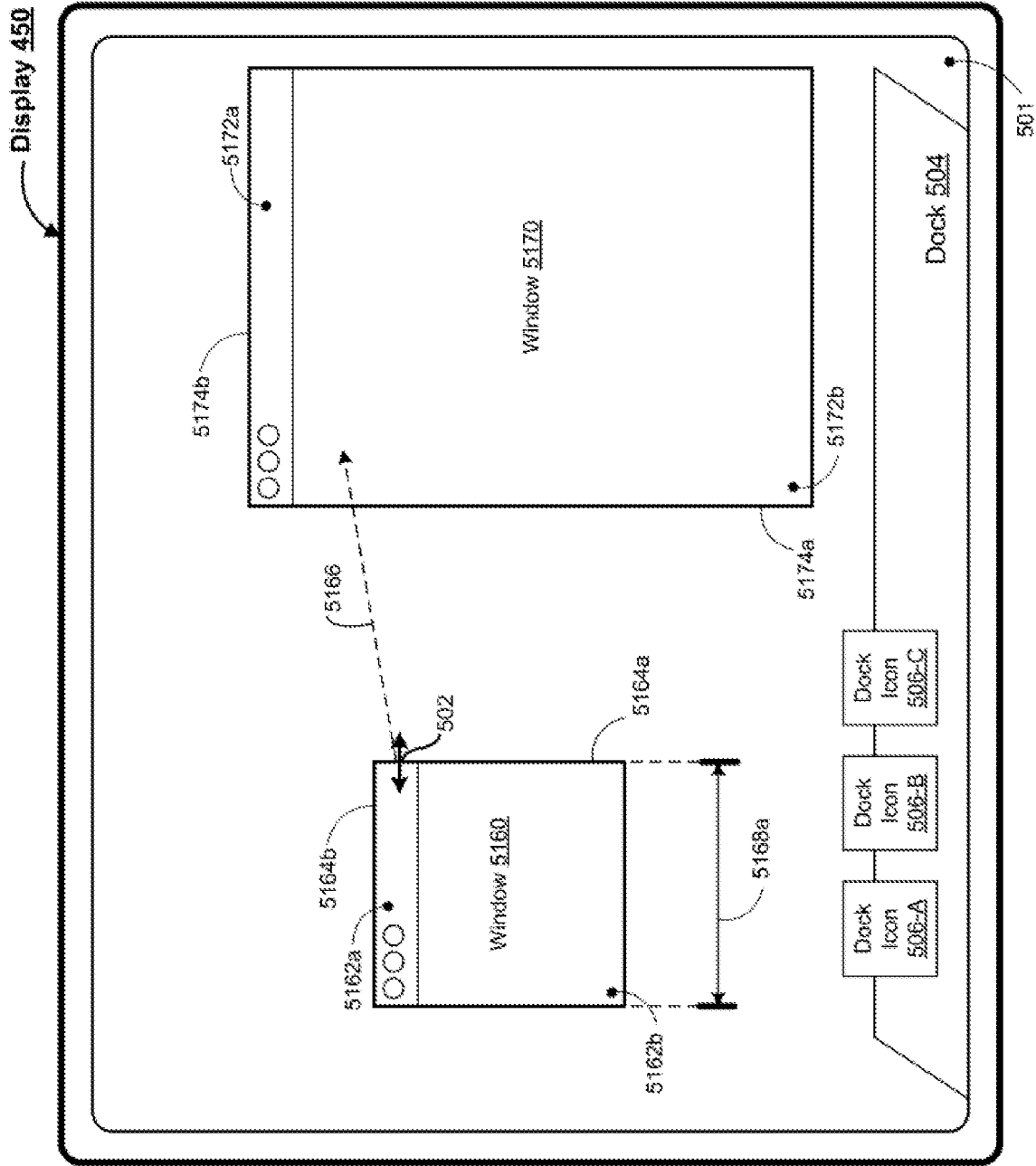

Figure 5UU

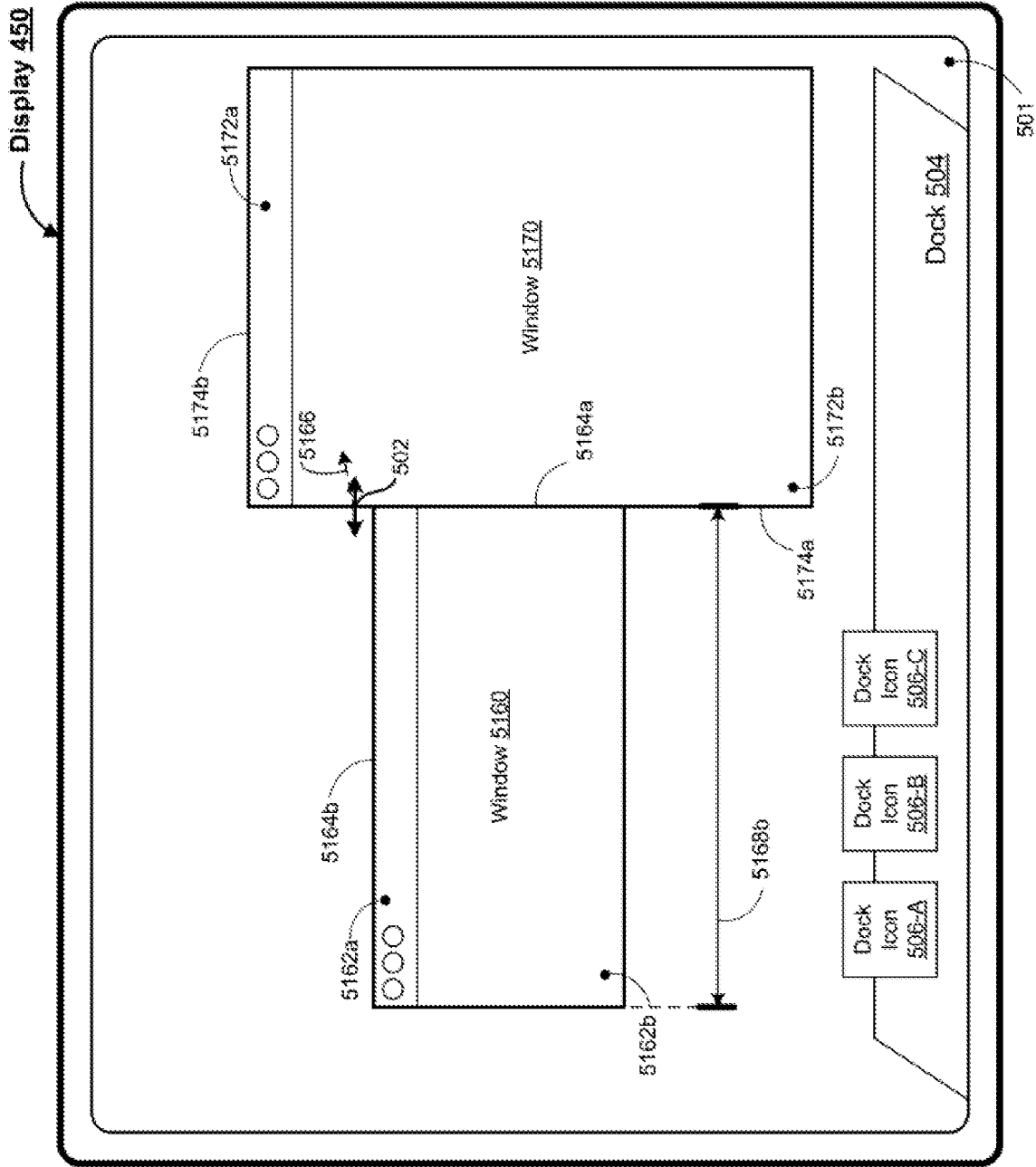

Figure 5W



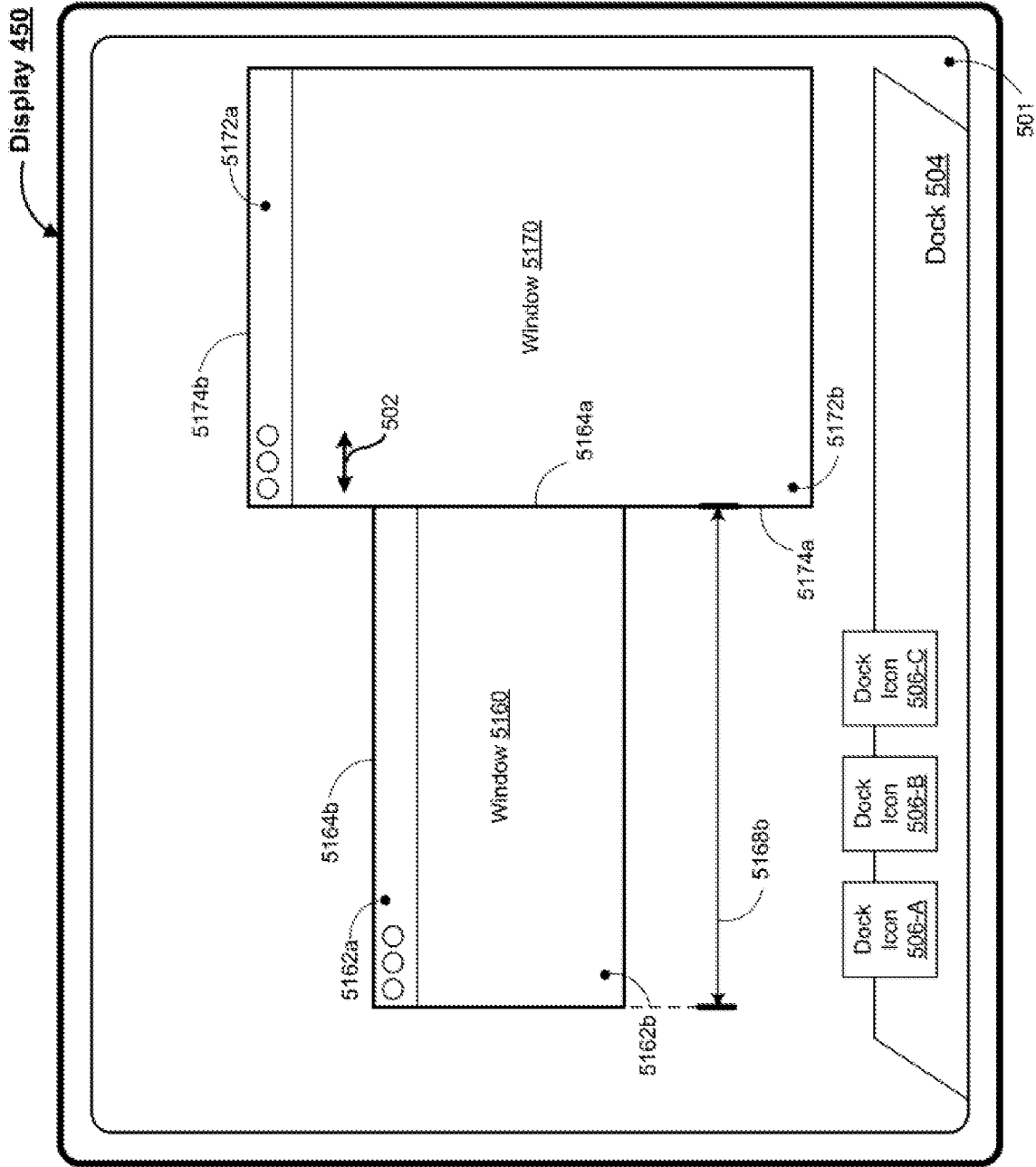

Figure 5WW

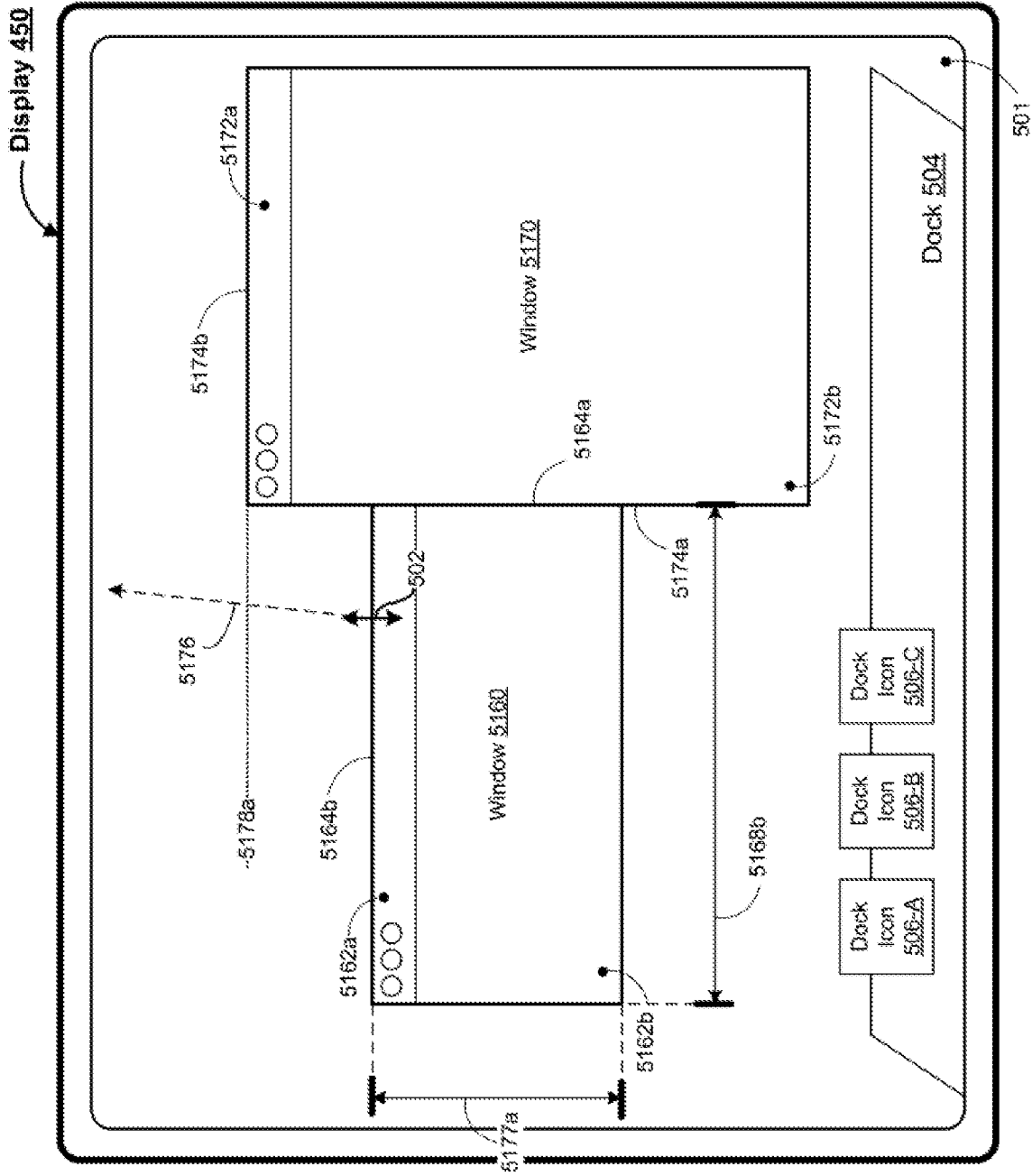

Figure 5XX

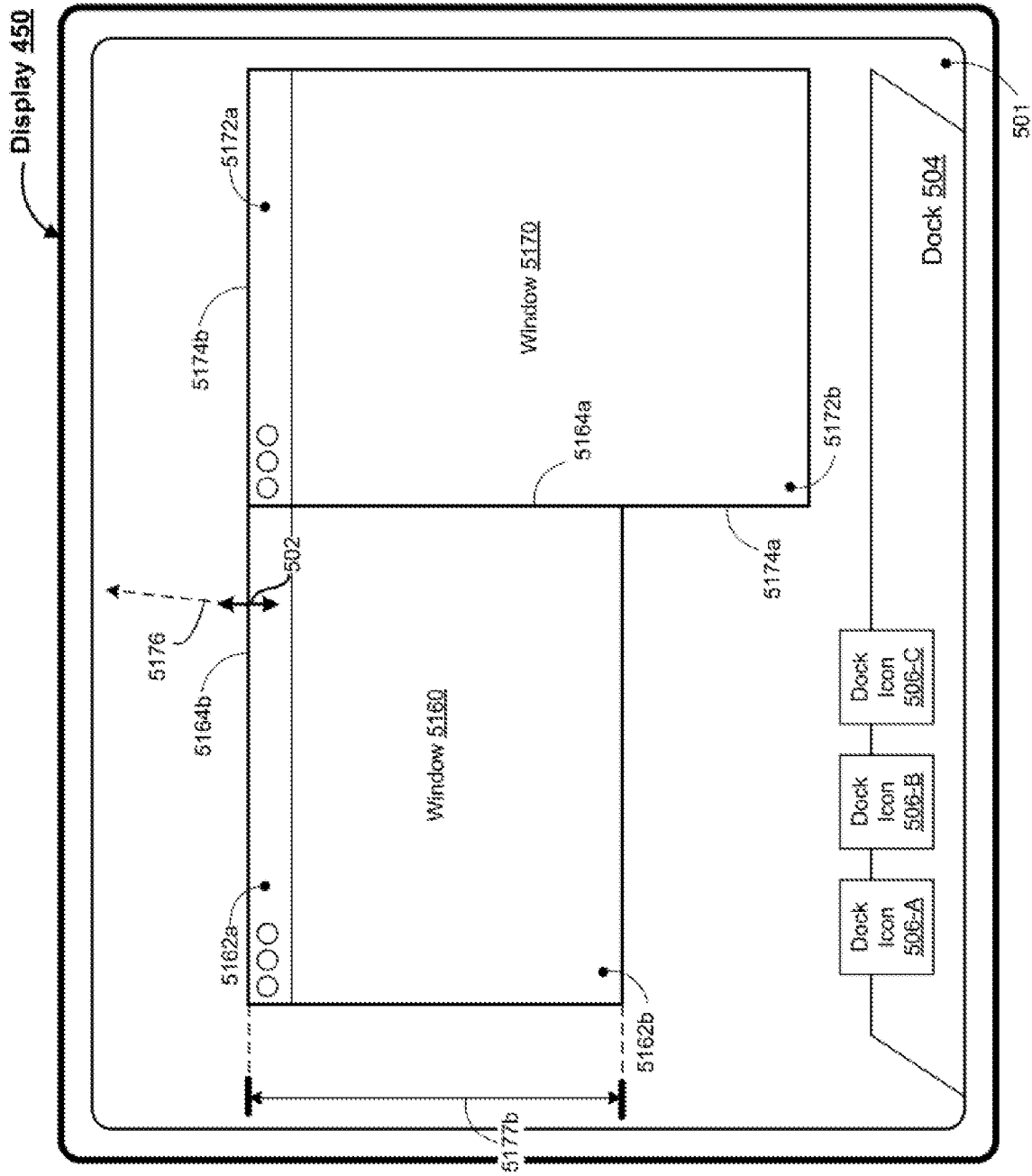

Figure 5YY

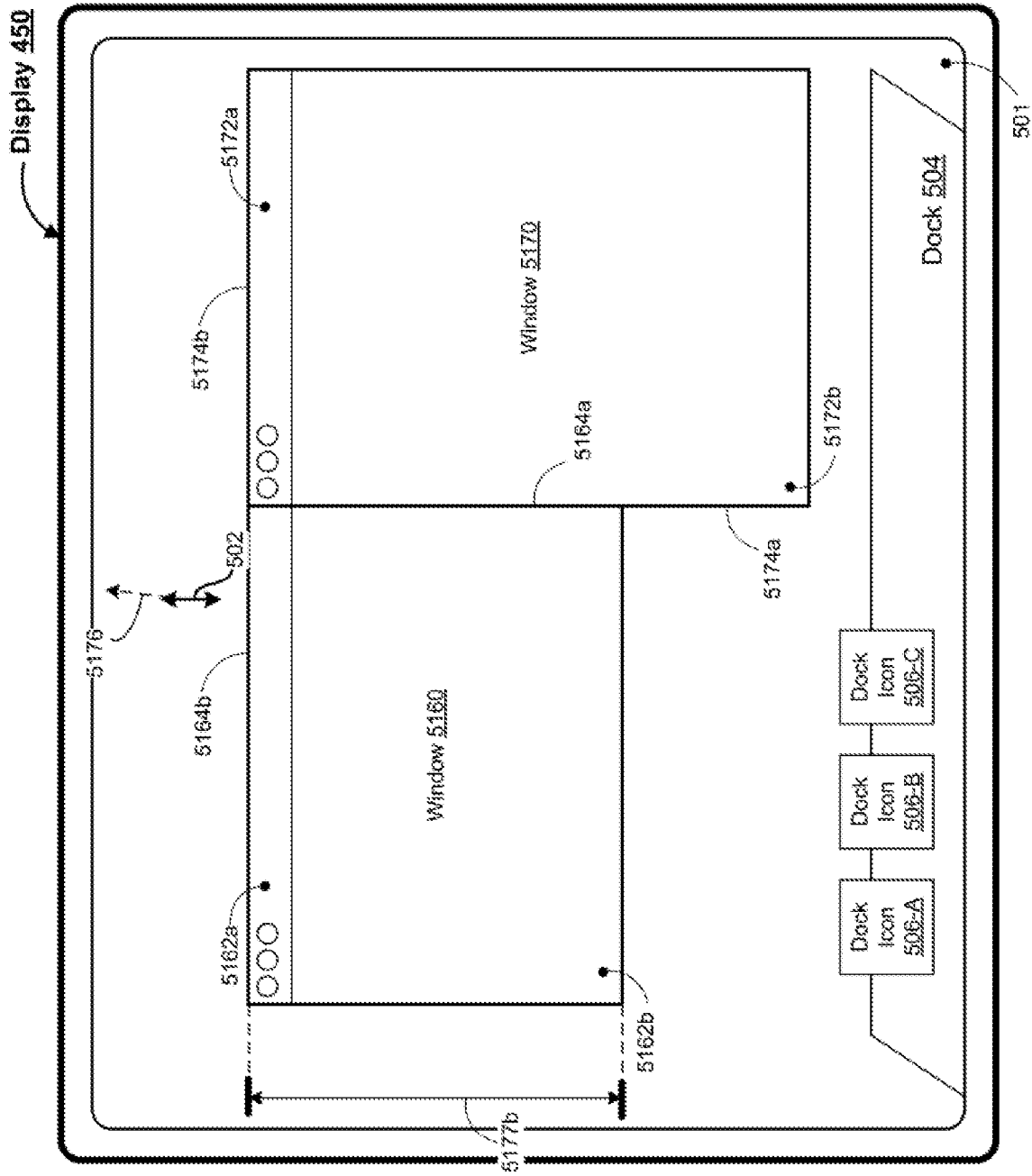

Figure 5ZZ

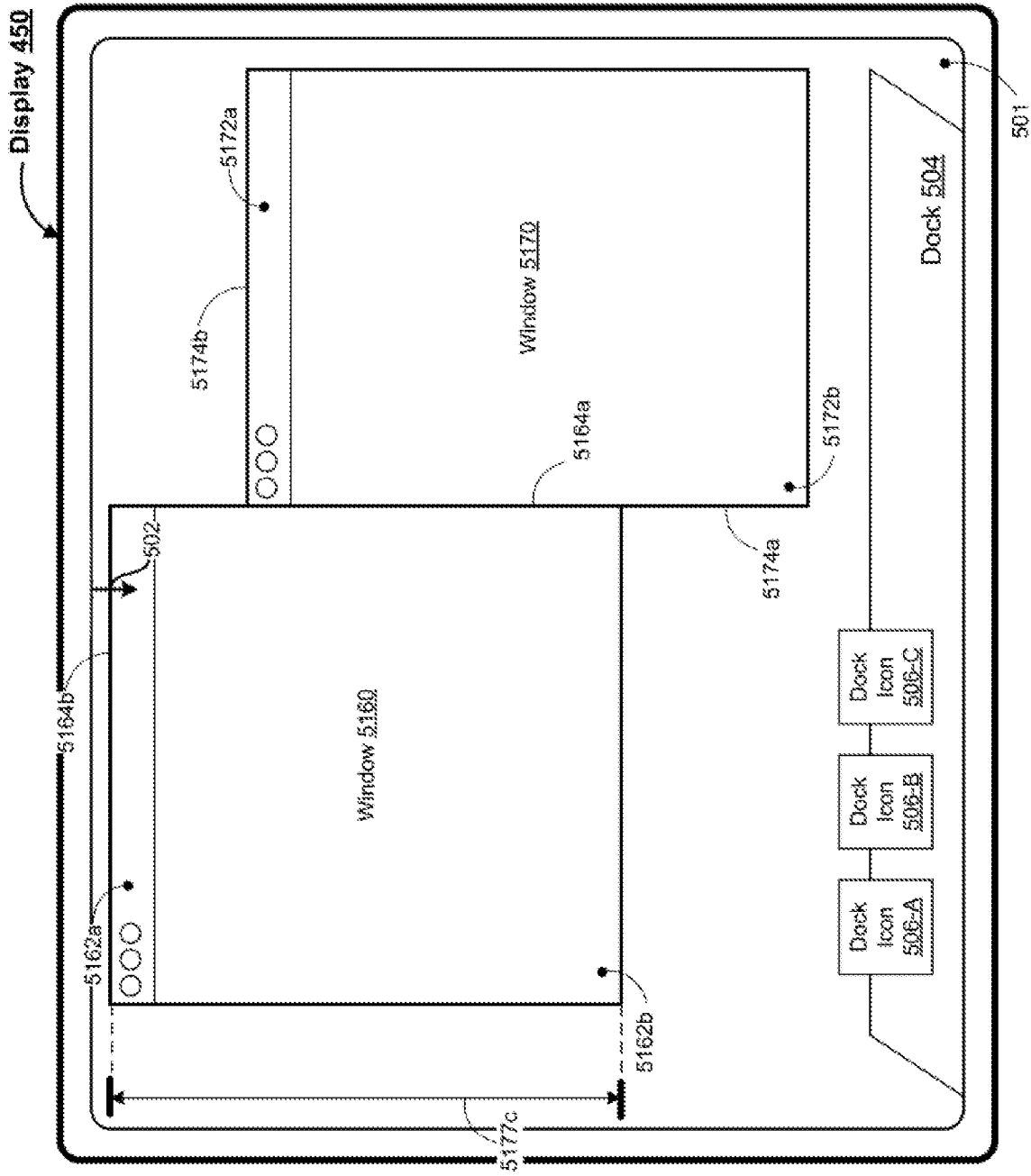

Figure 5AAA

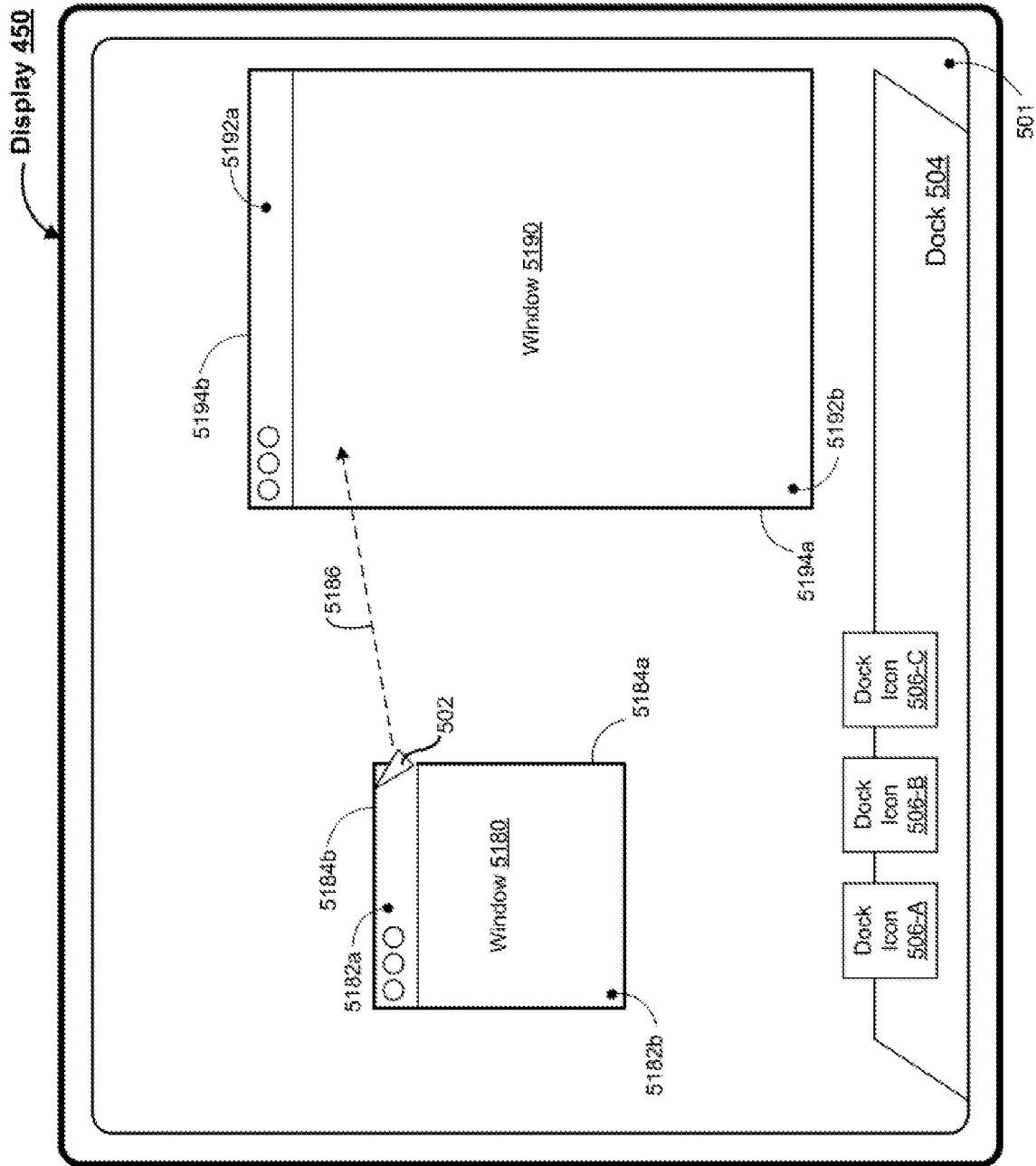
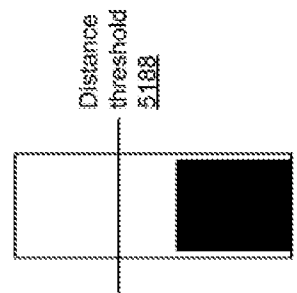
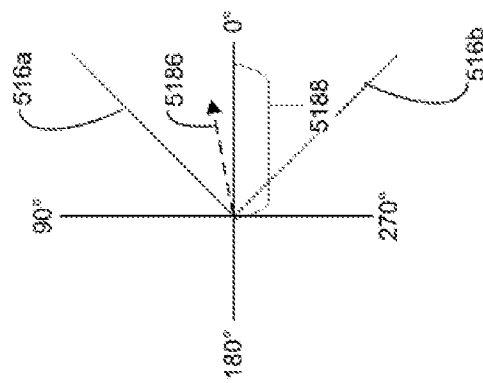

Figure 5BBB



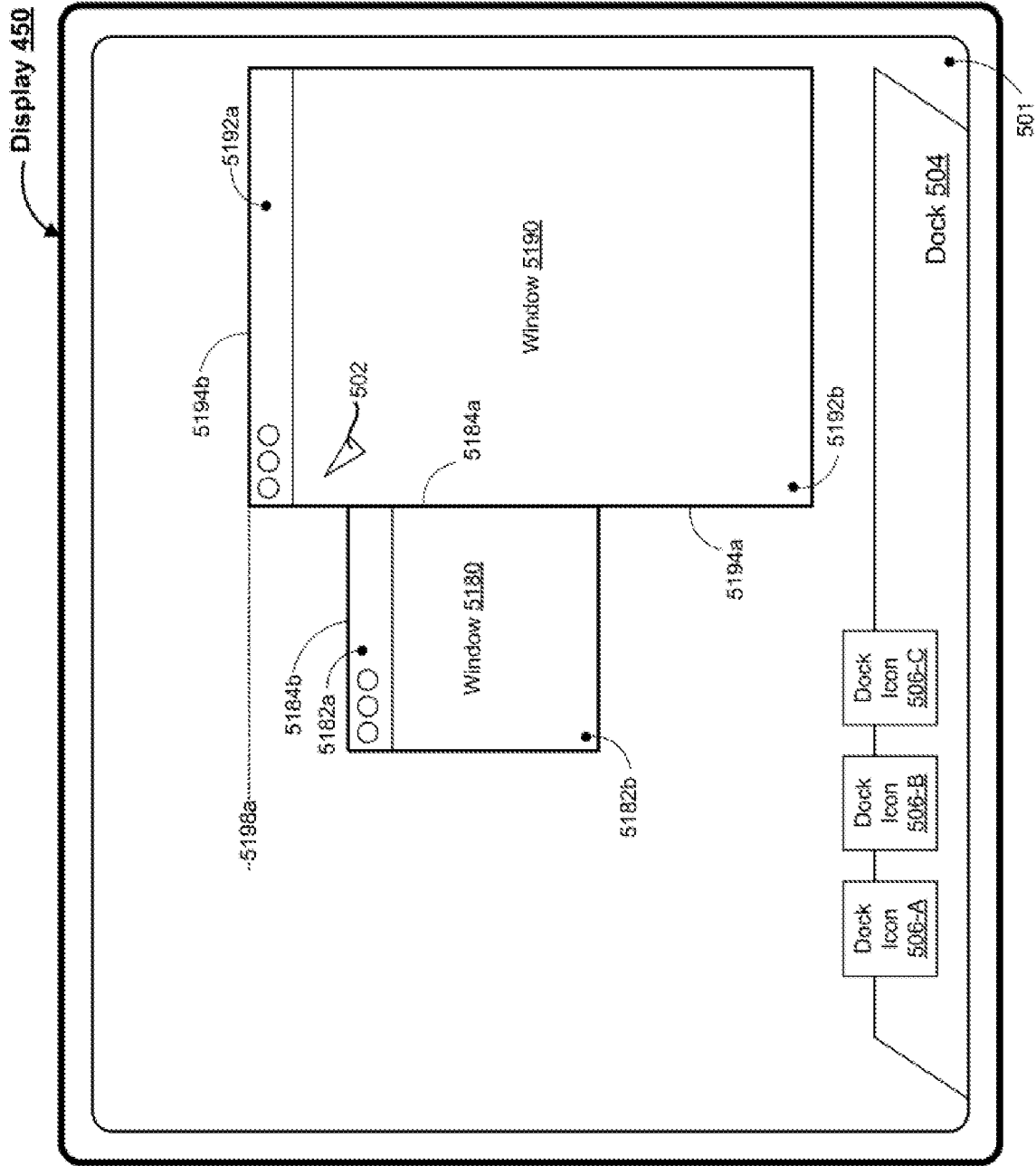

Figure 5CCC

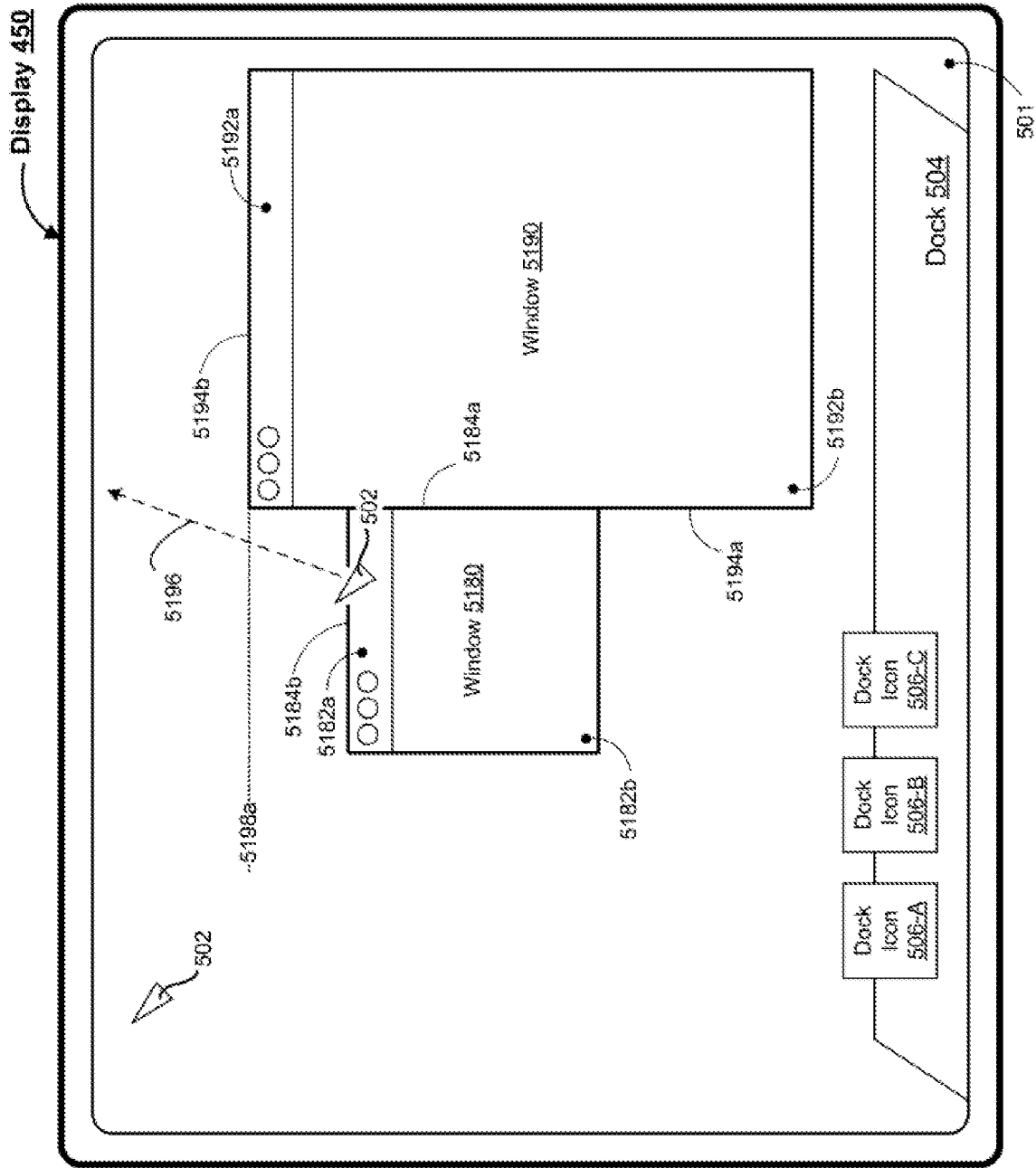
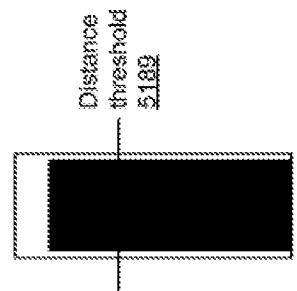
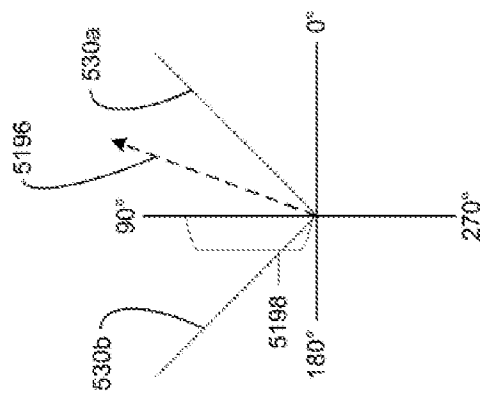
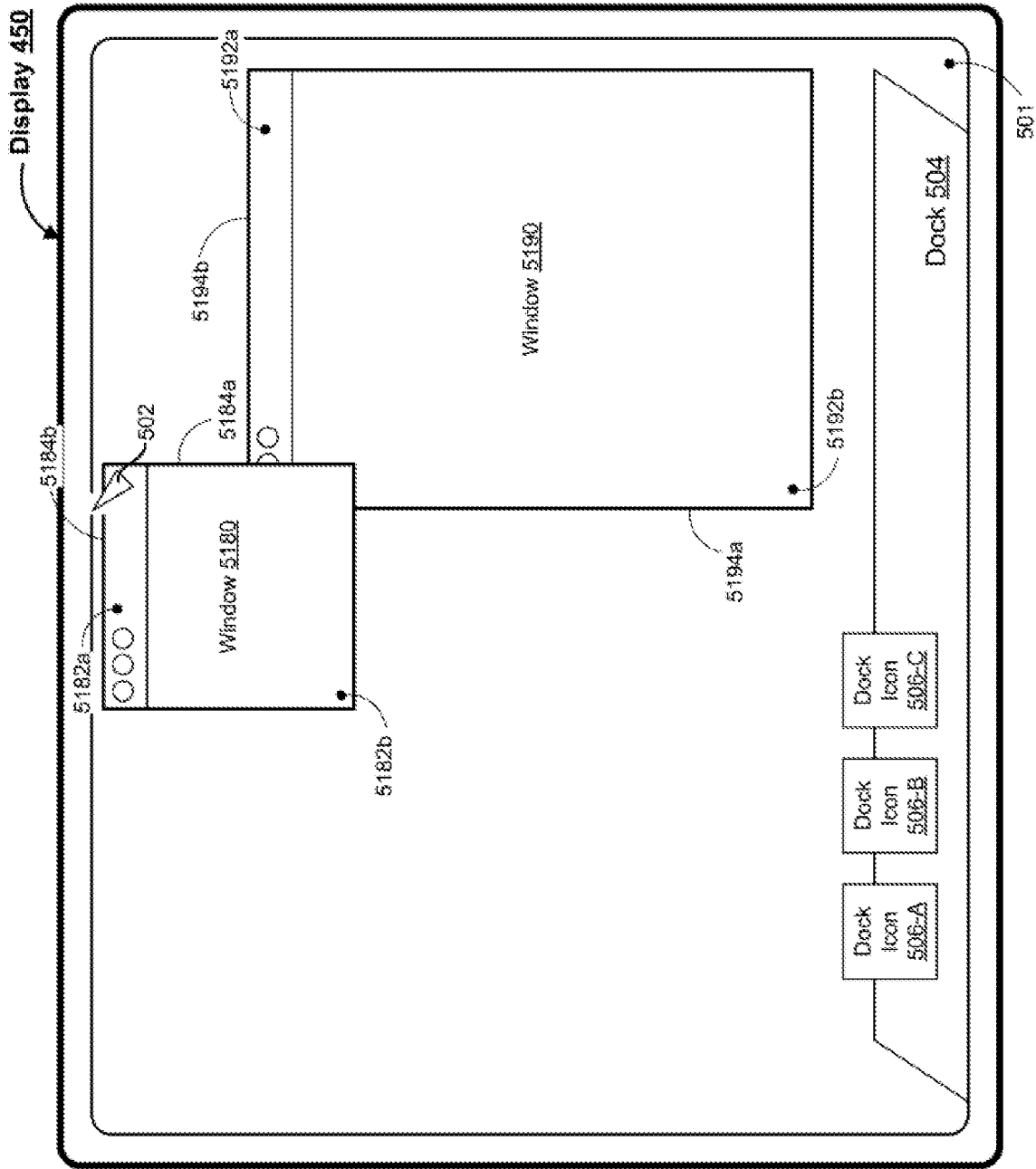

Figure 5DDDD







**Figure 5EEE**

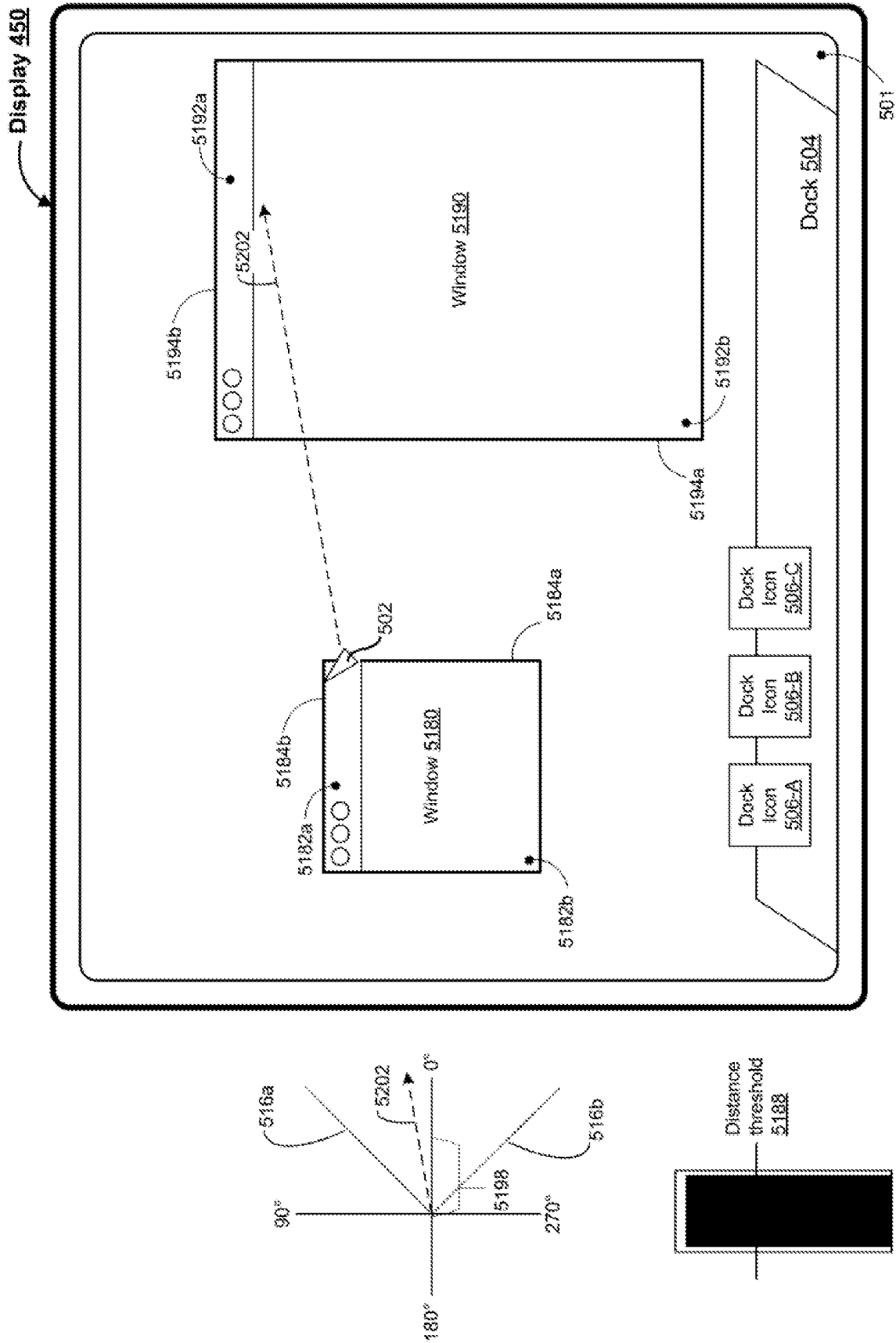

Figure 5FFF

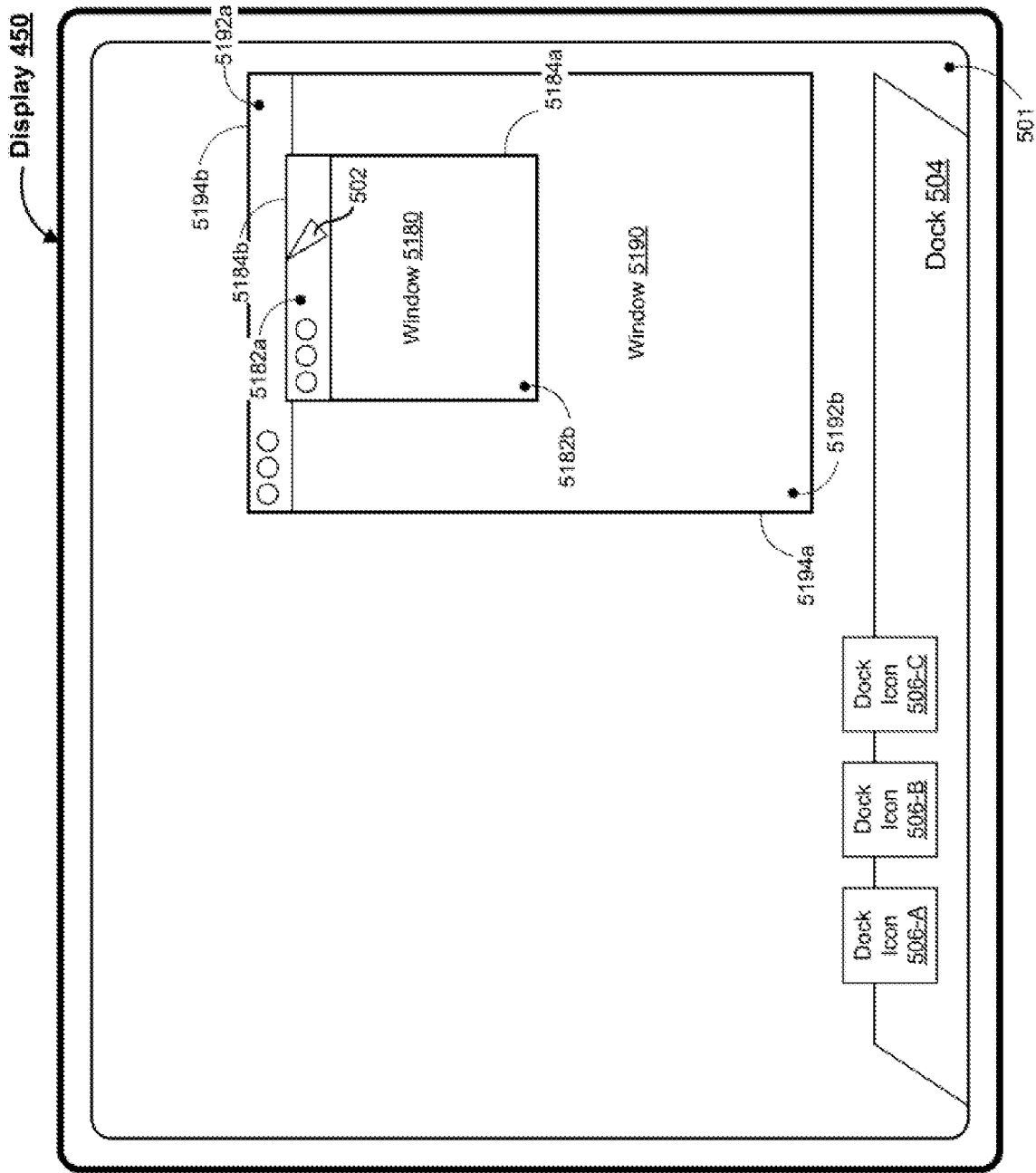

Figure 5GGG

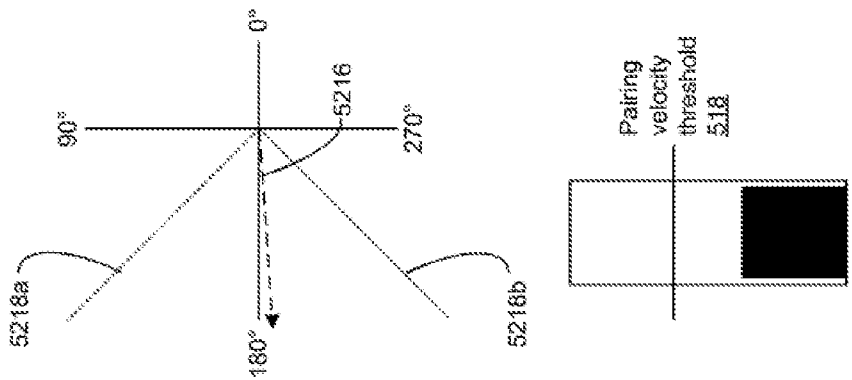
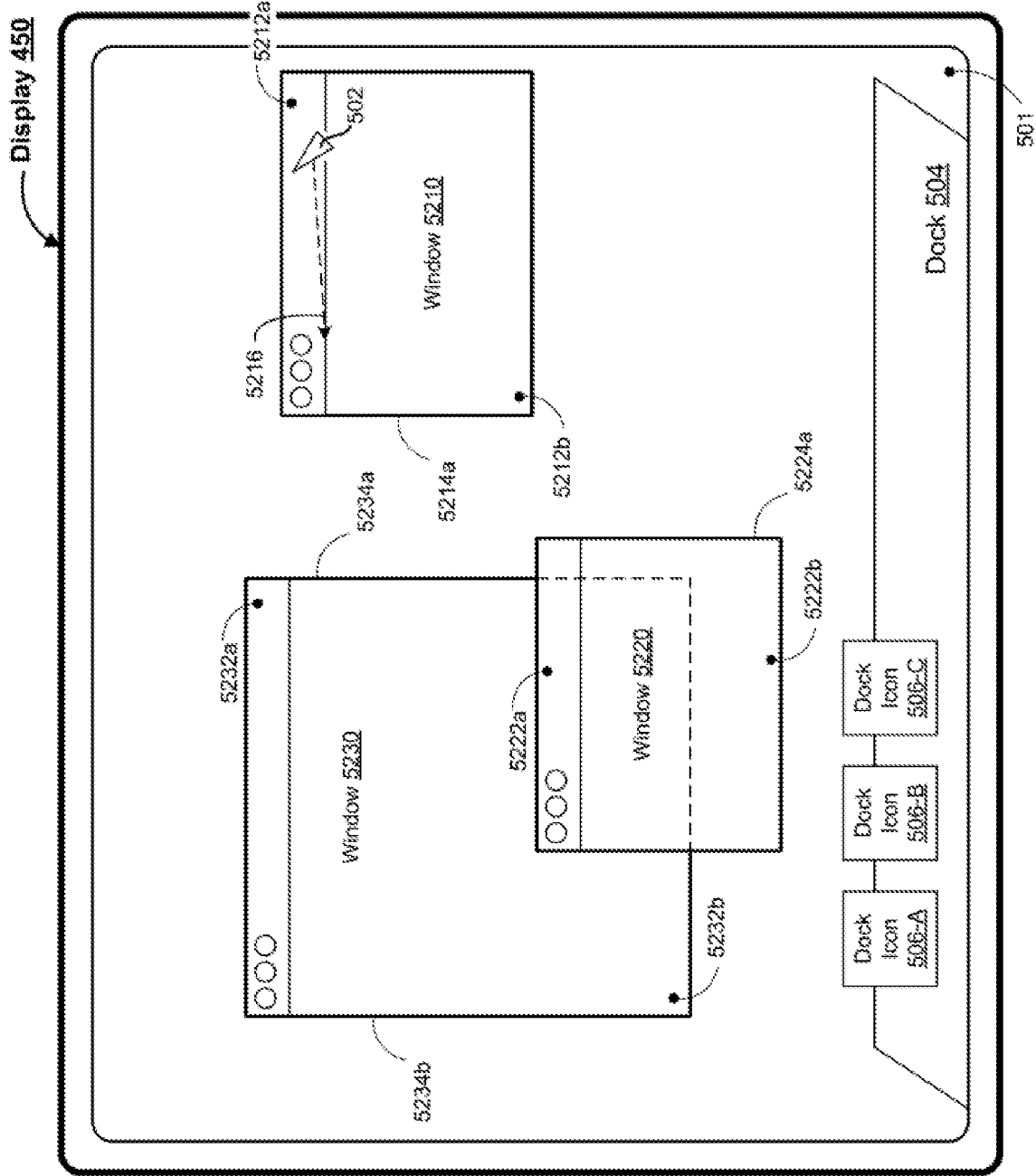

Figure 5HHH

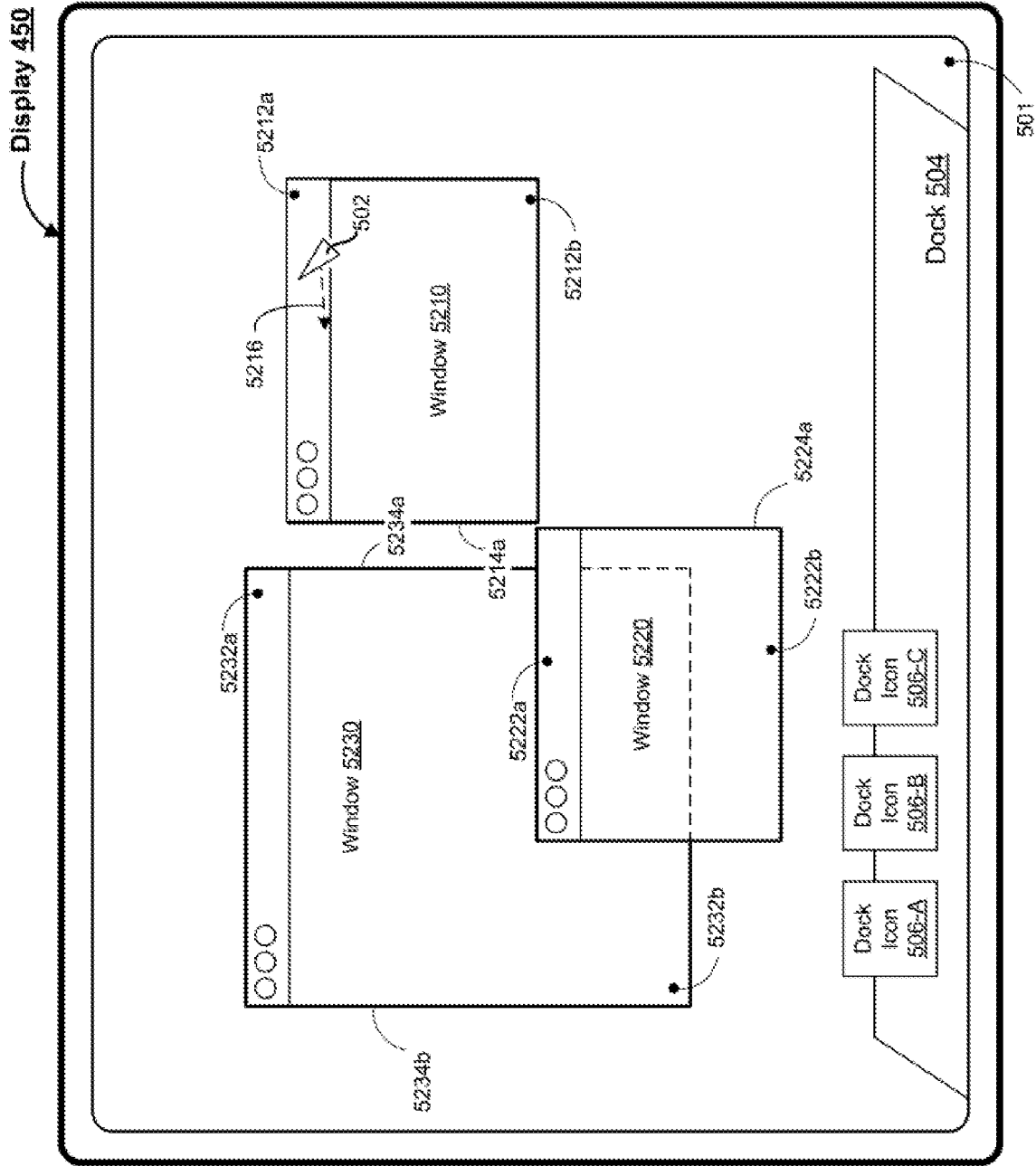

Figure 5III

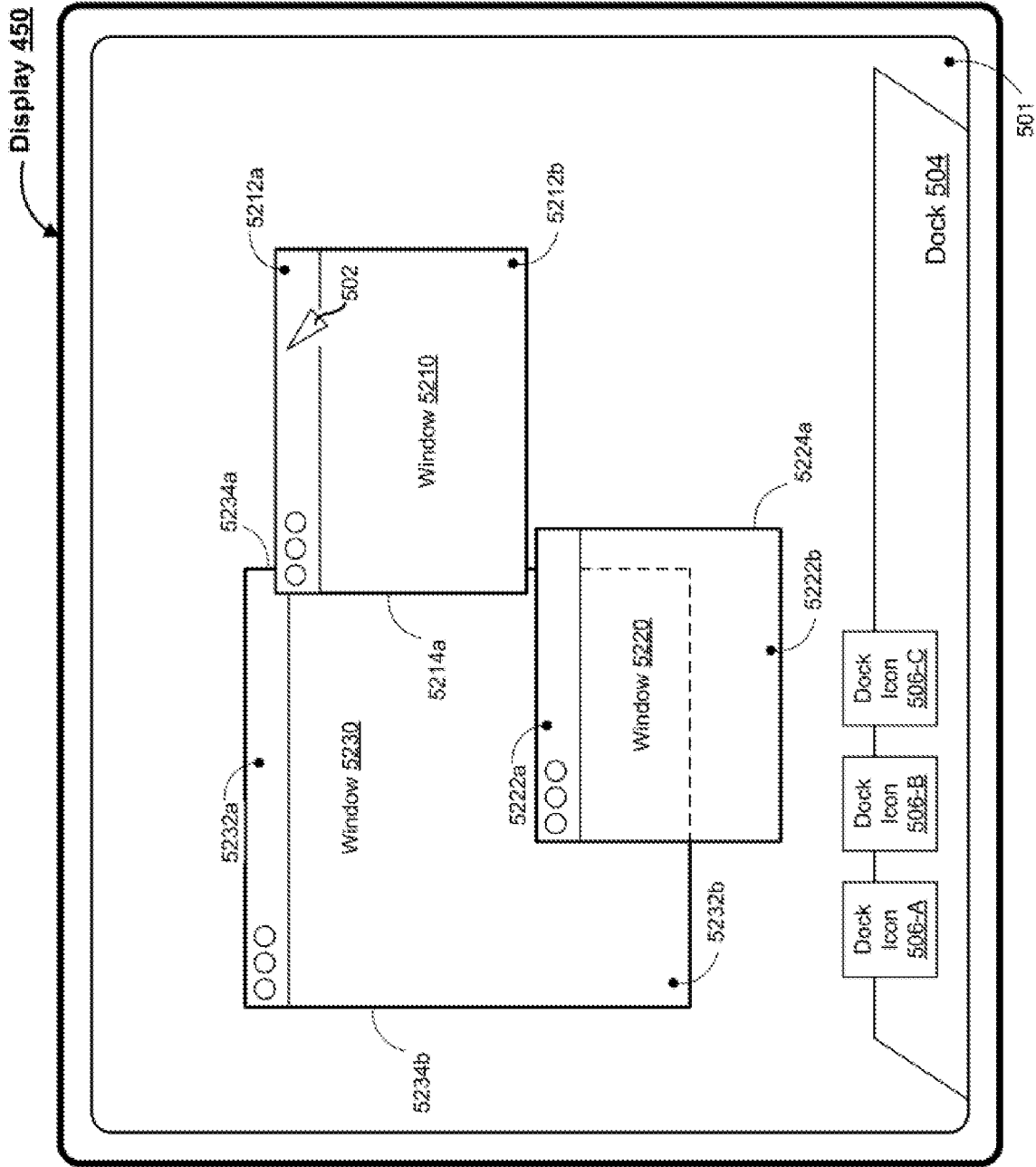

Figure 5JJJ

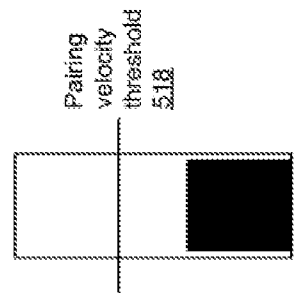
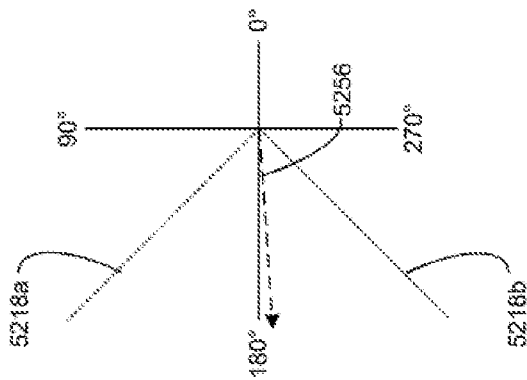
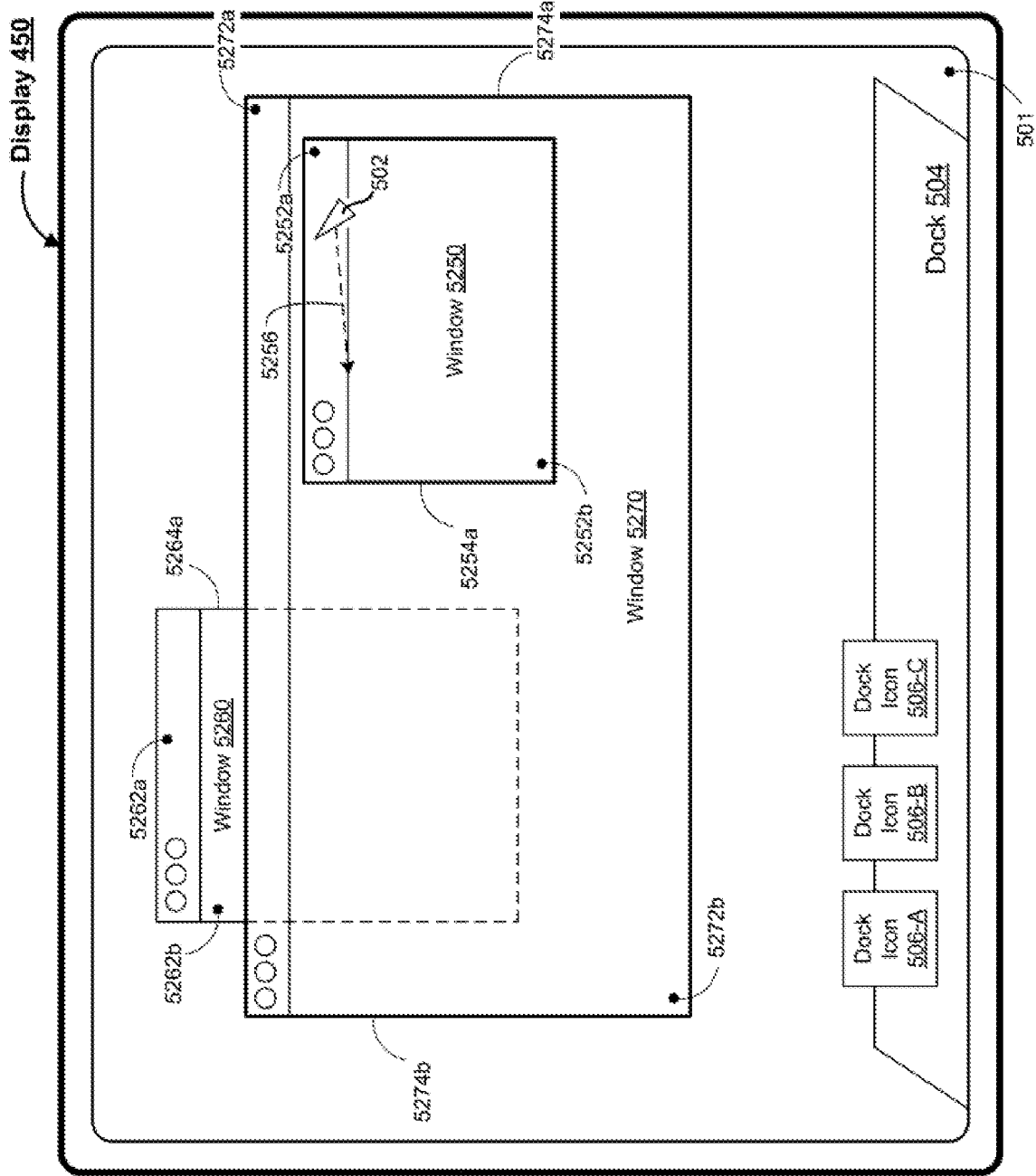

Figure 5KKK

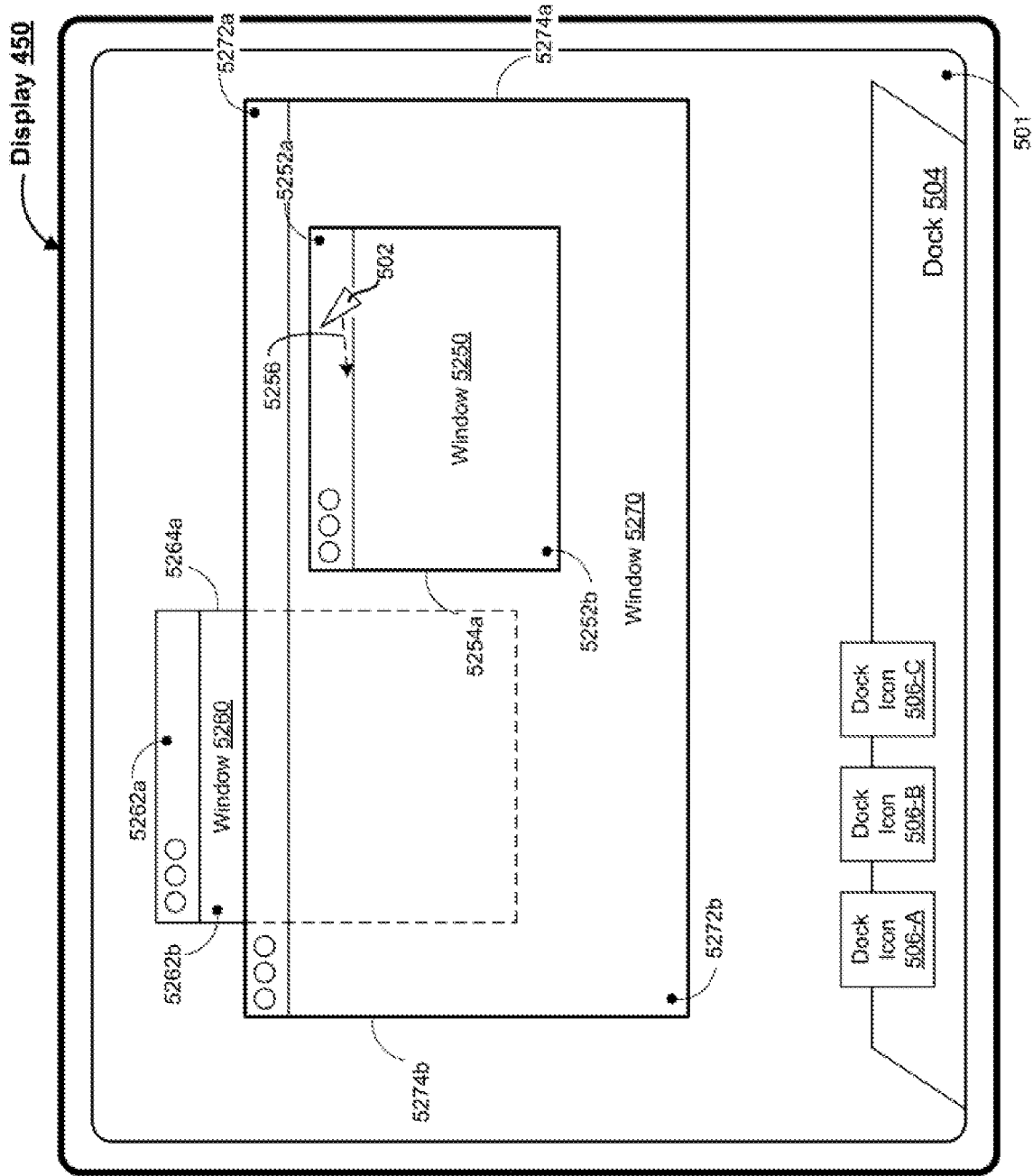

Figure 5LLL



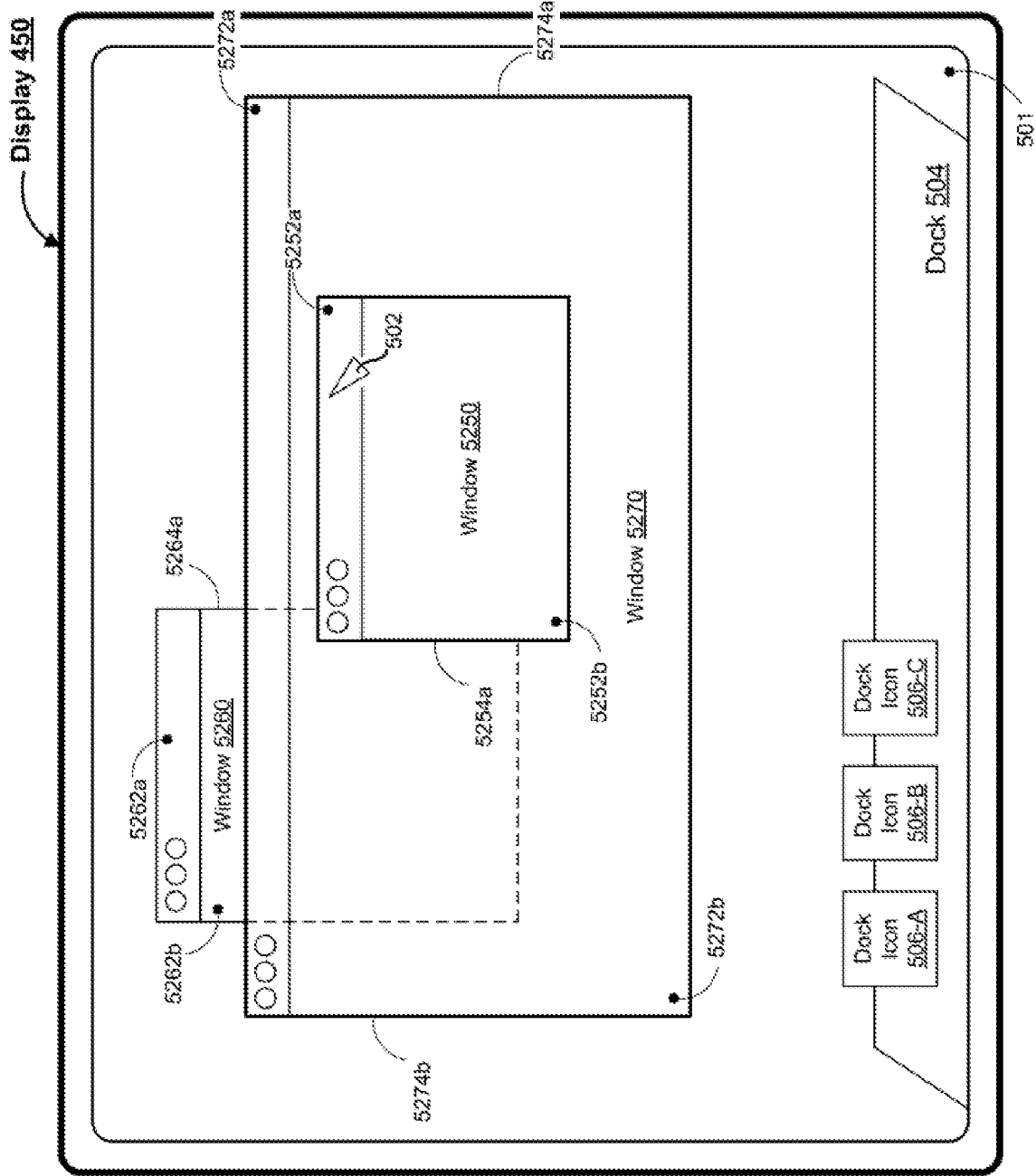

Figure 5MMM

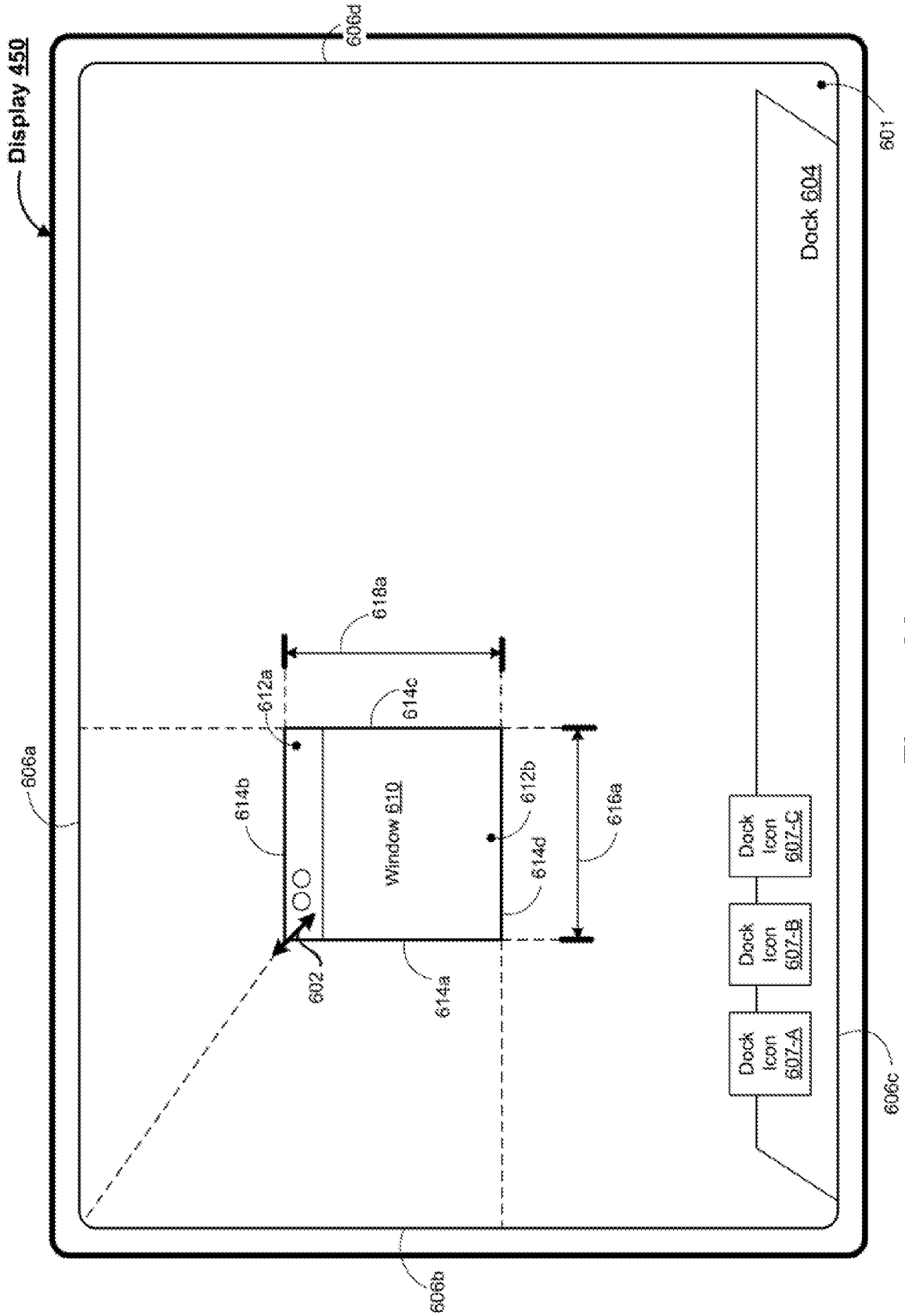

Figure 6A

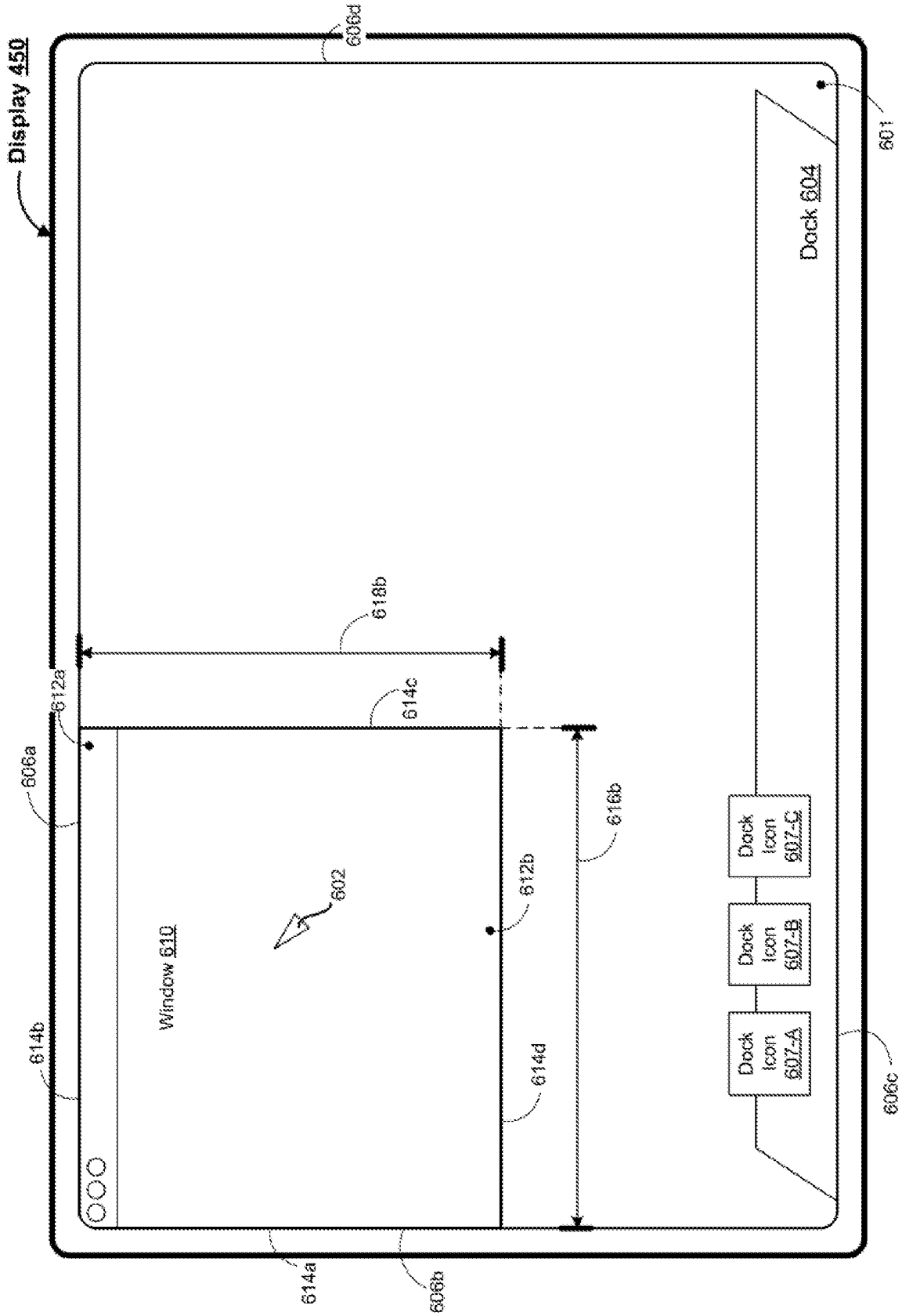

Figure 6B

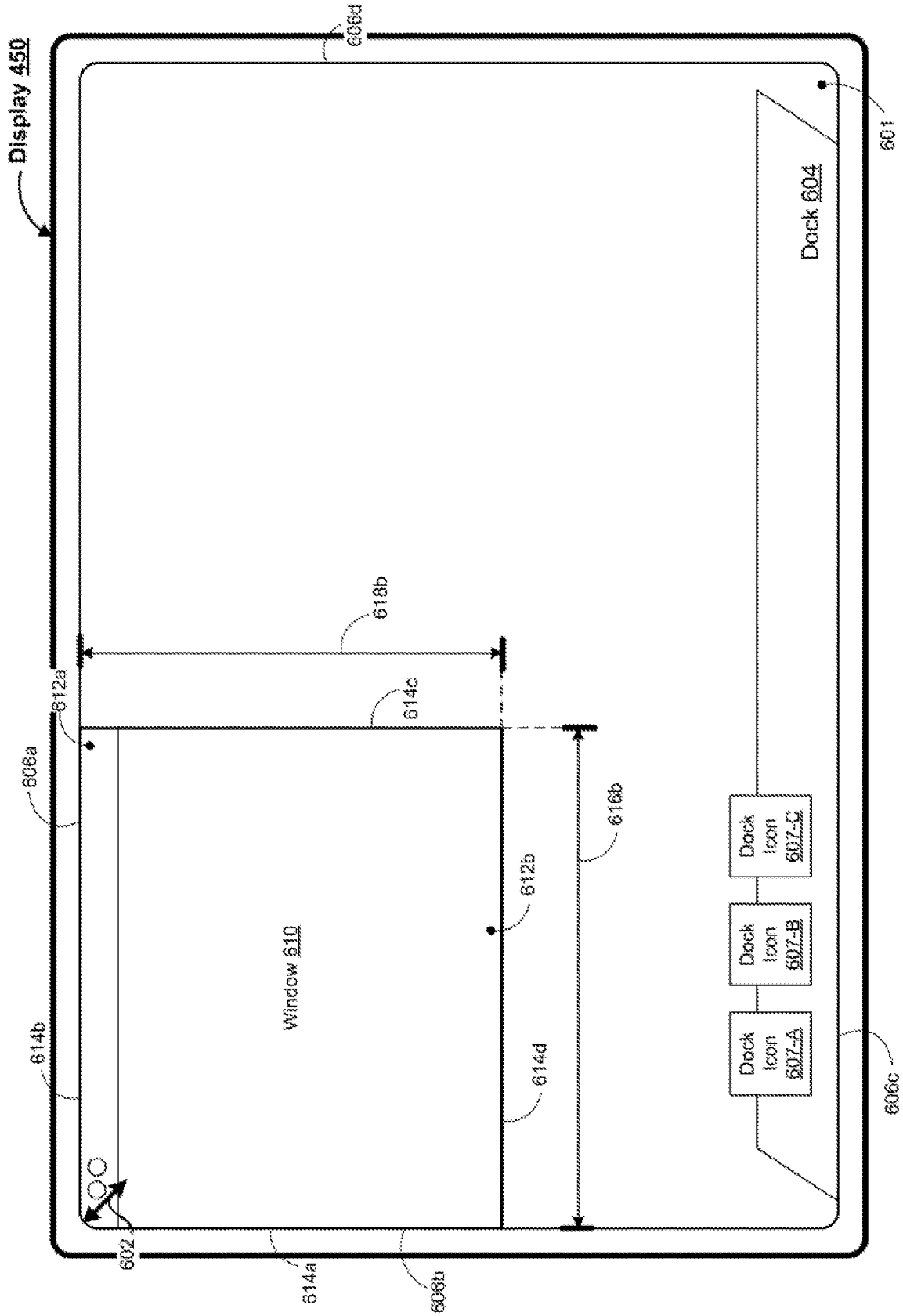

Figure 6C

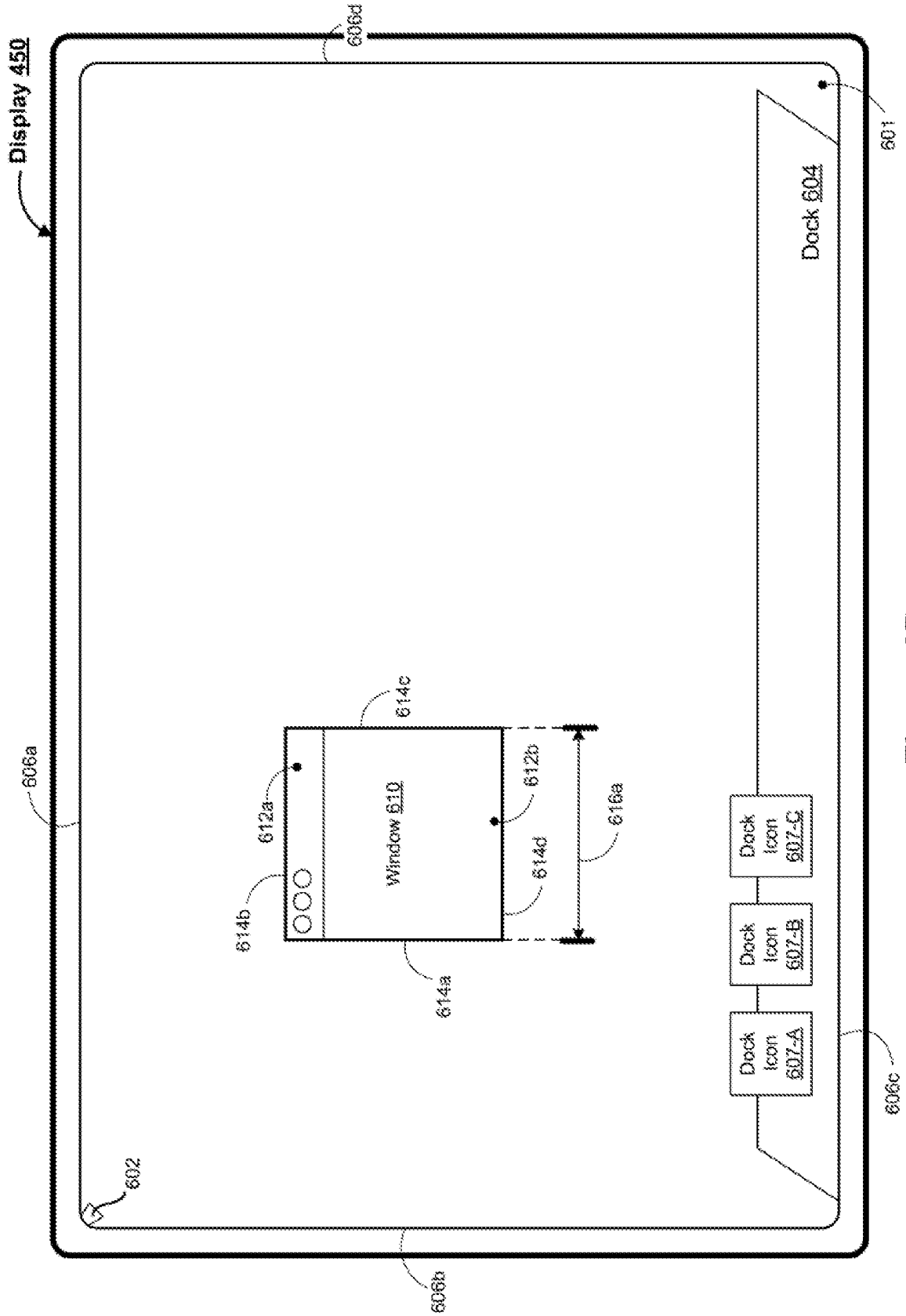

Figure 6D

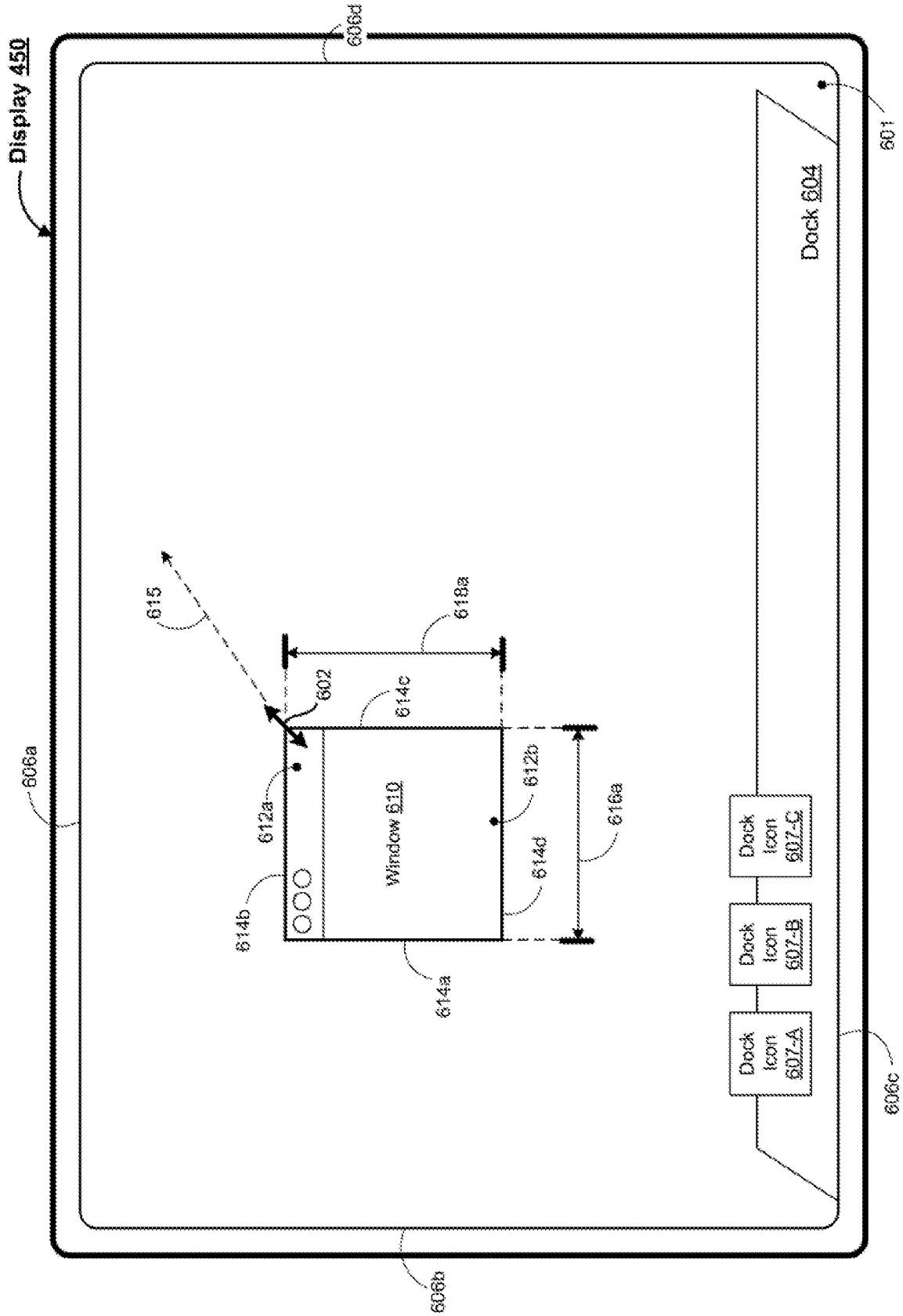

Figure 6E

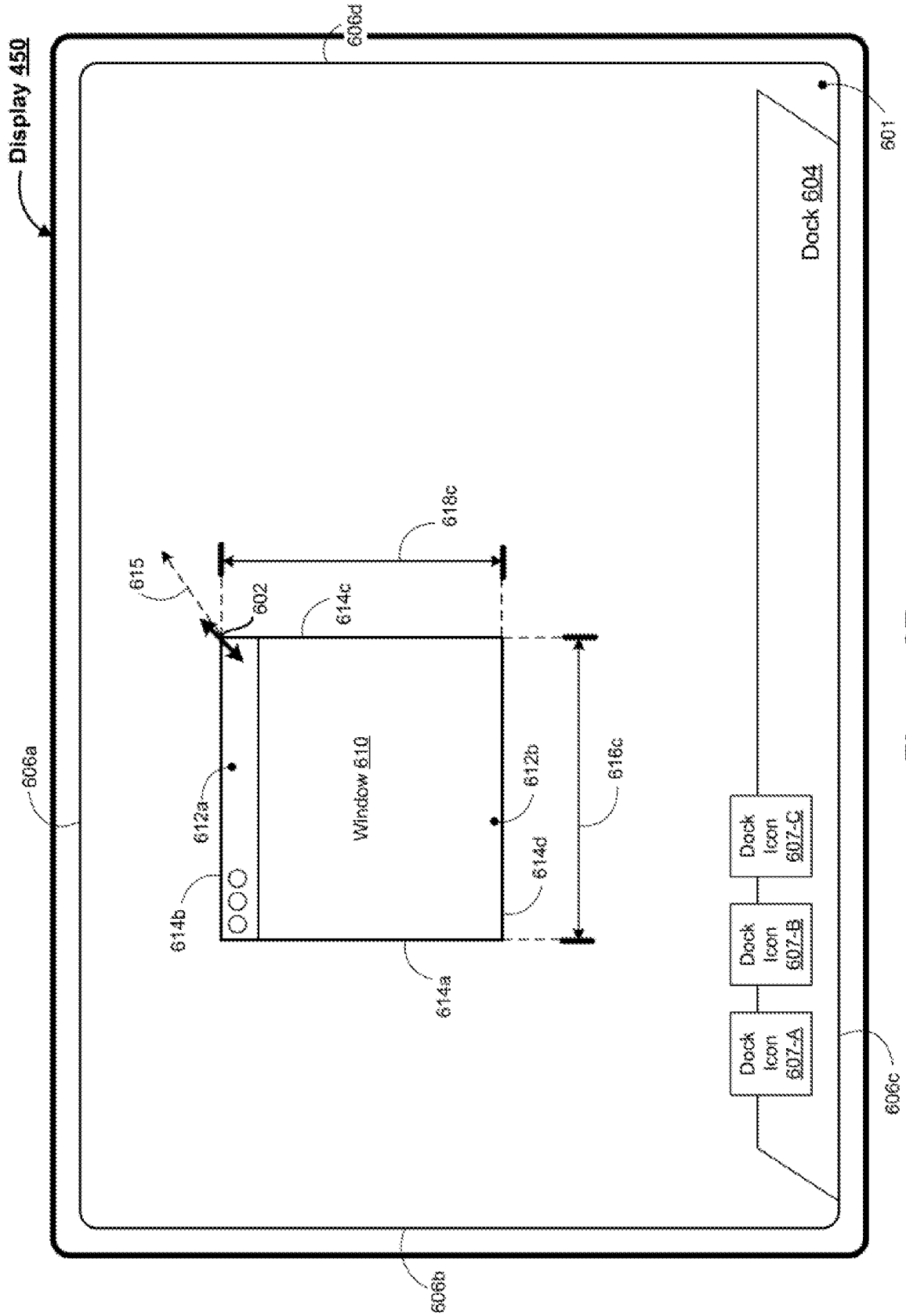

Figure 6F

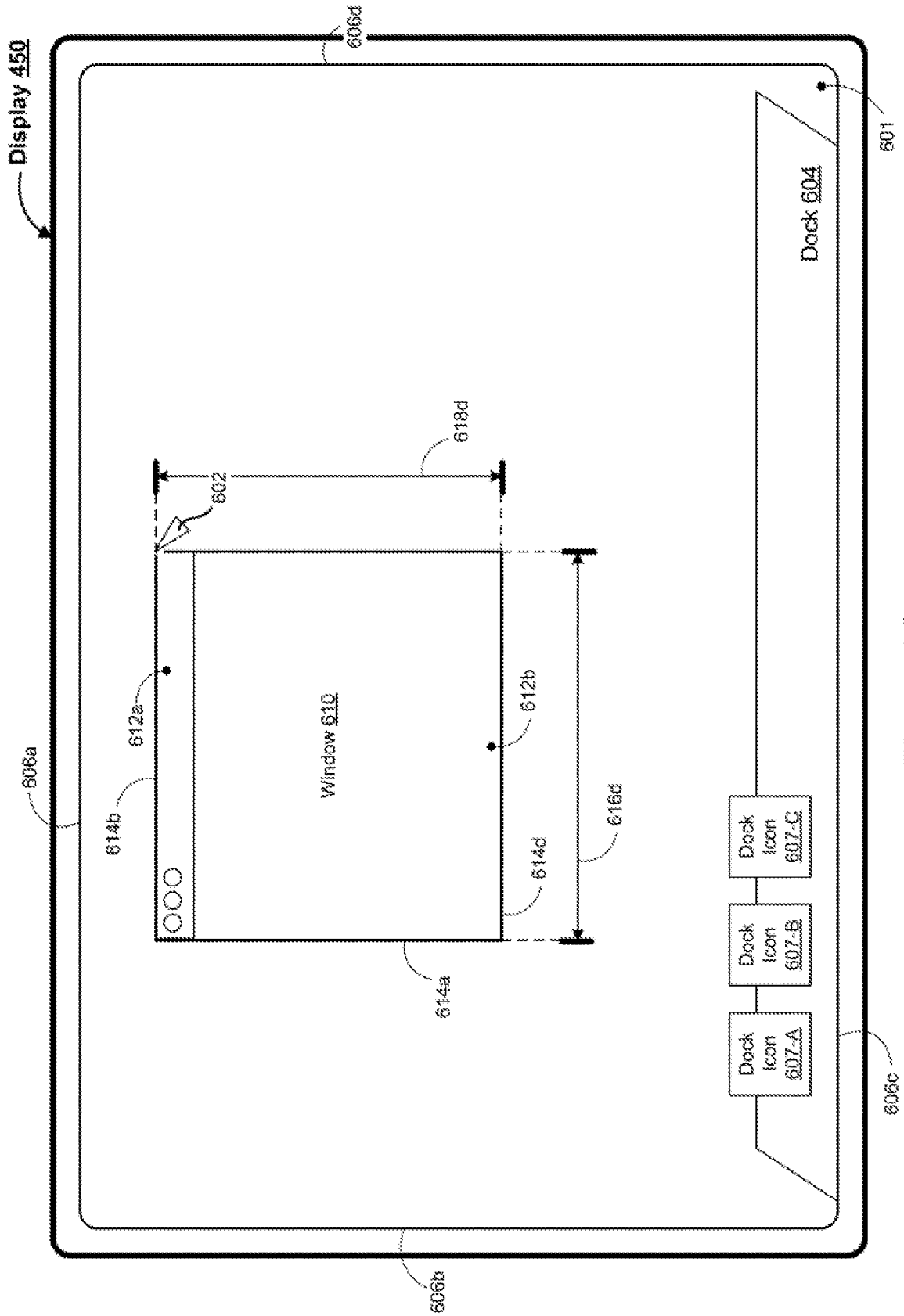

Figure 6G



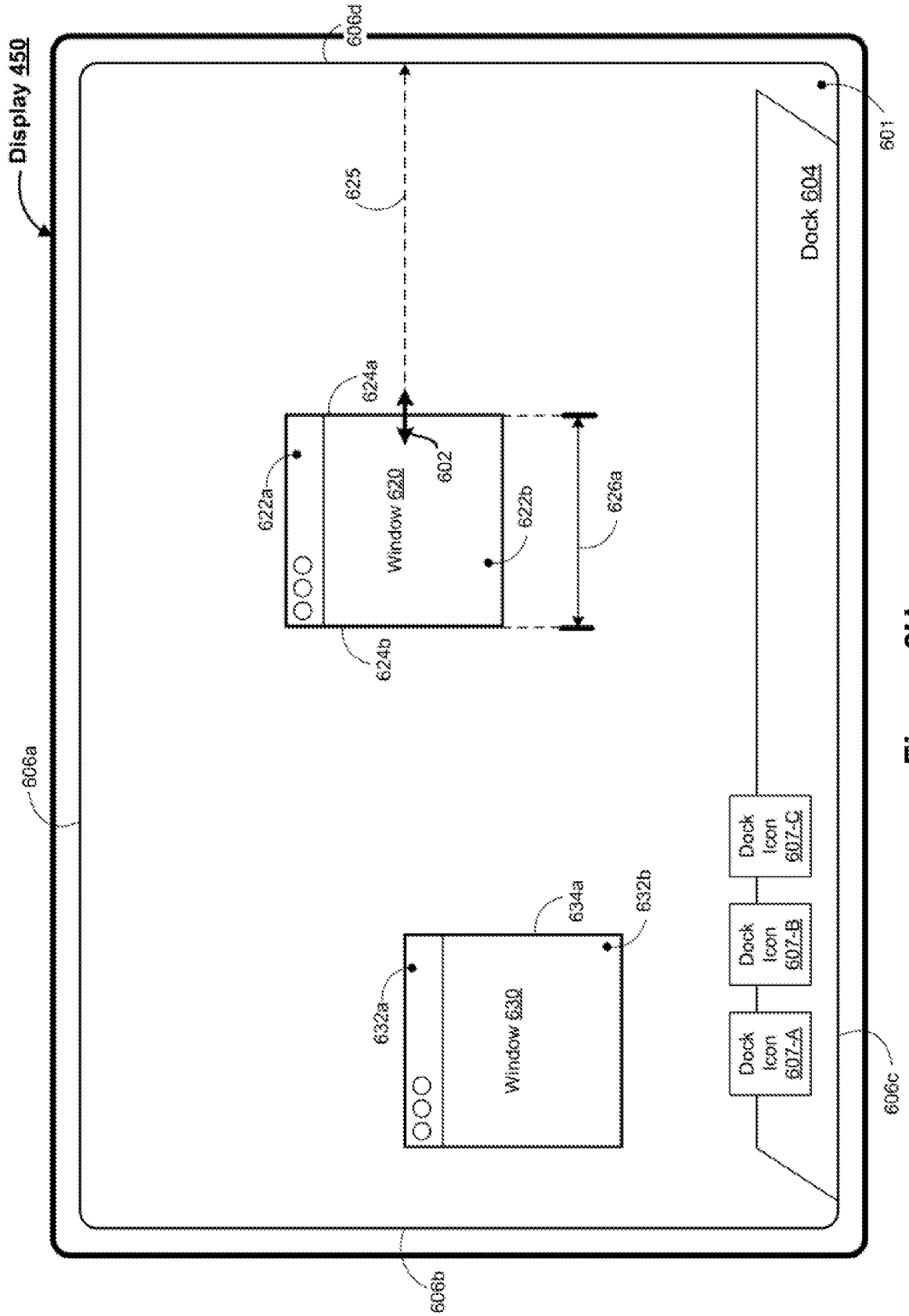

Figure 6H

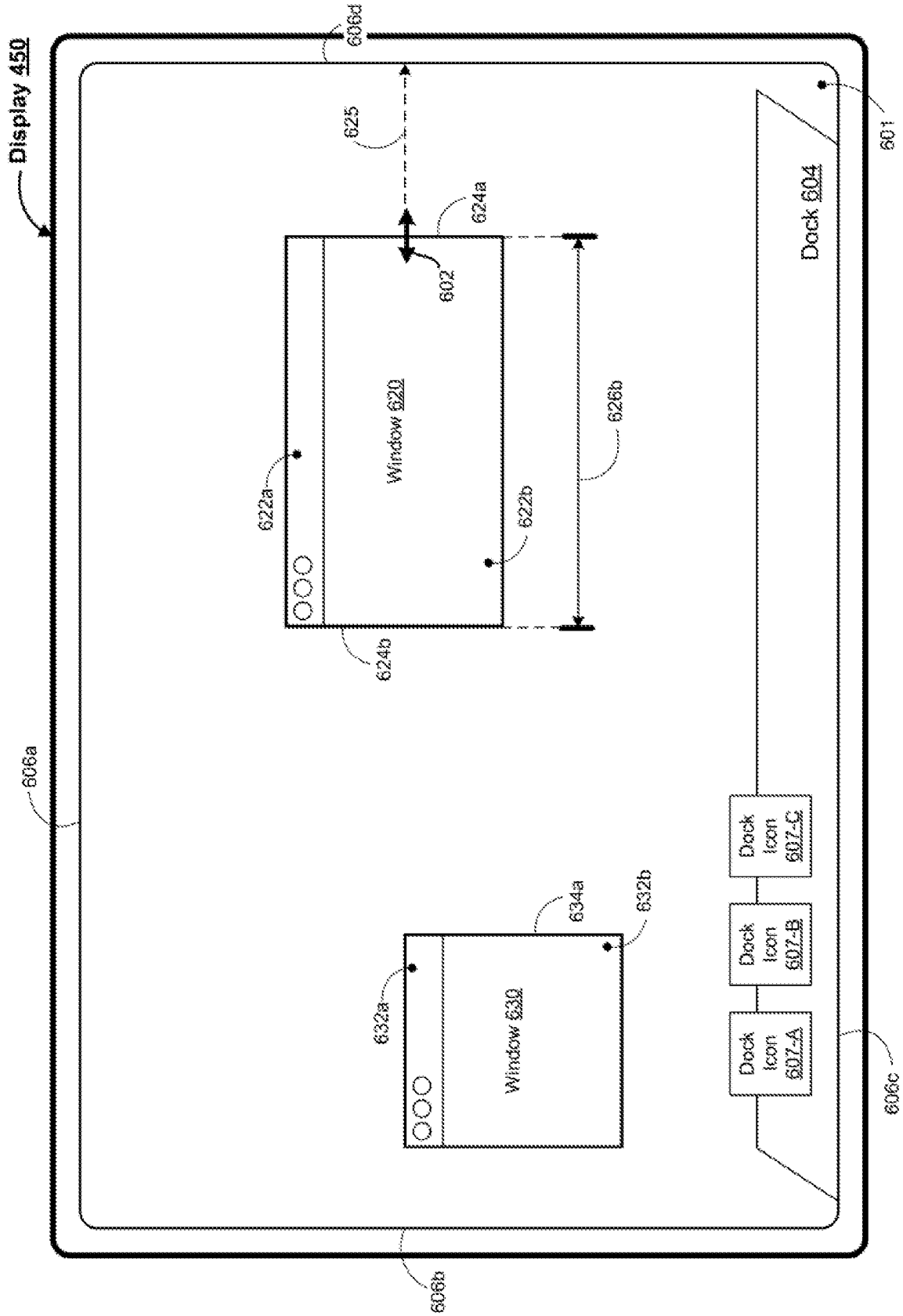

Figure 6I

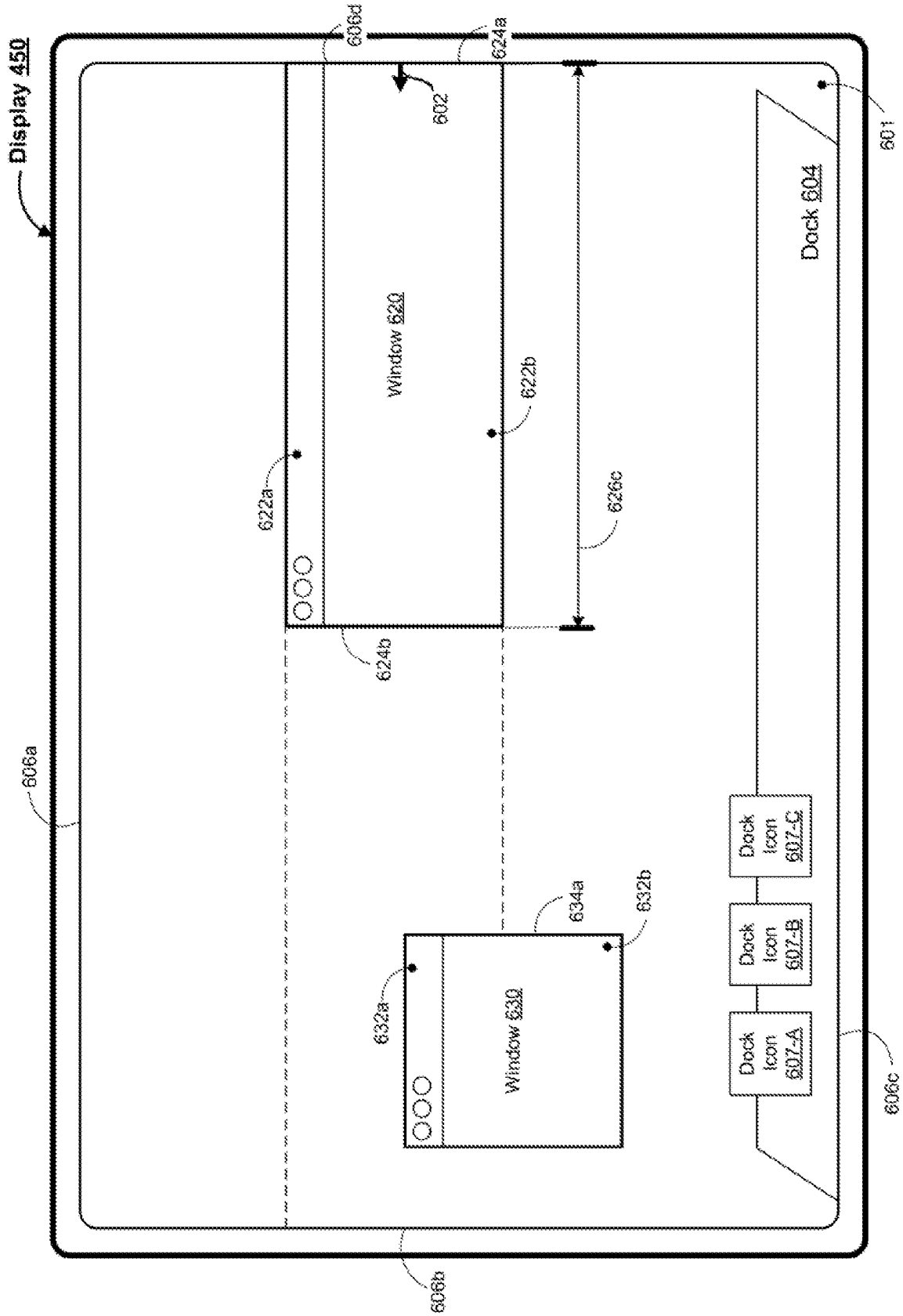

Figure 6J

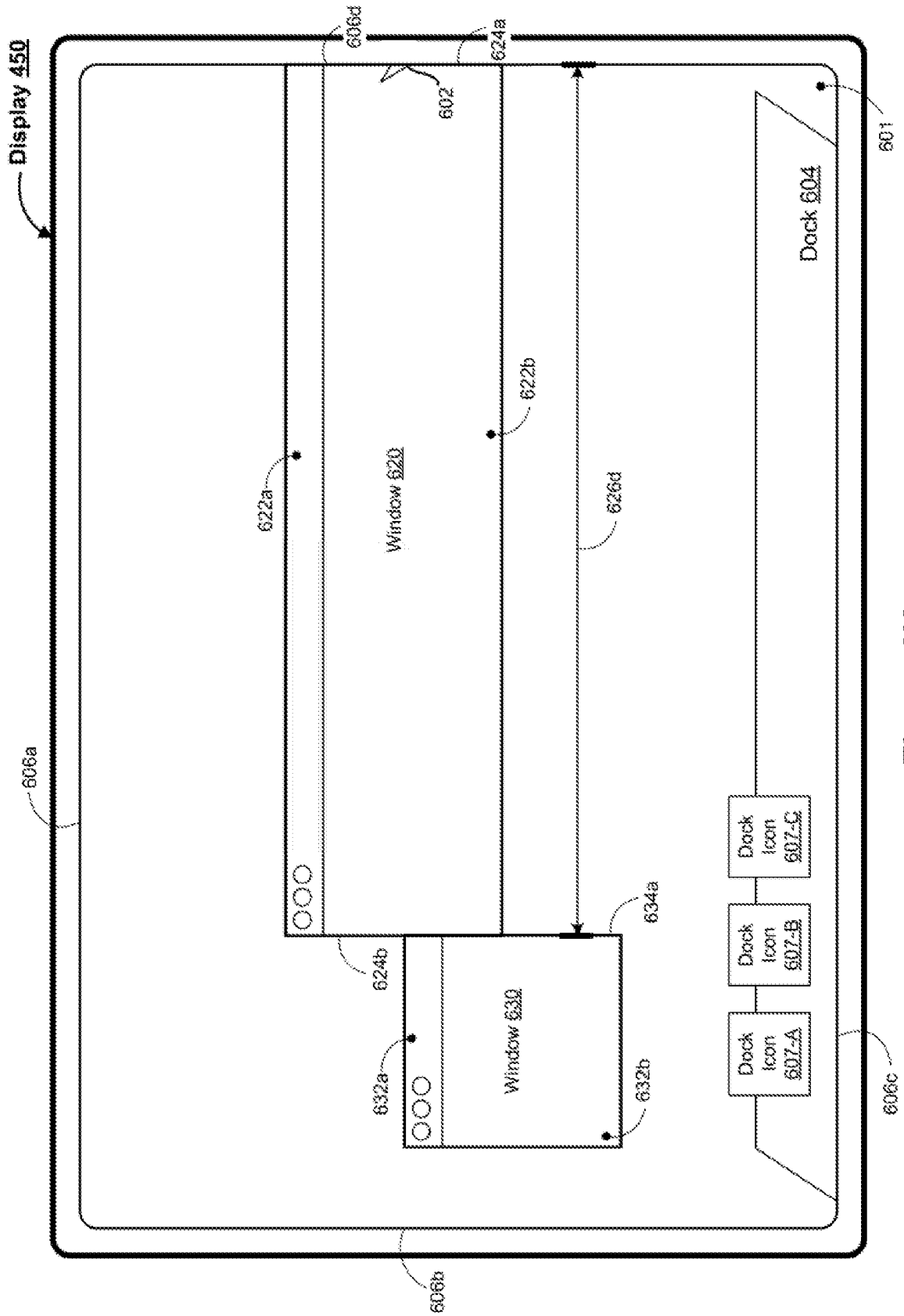

Figure 6K

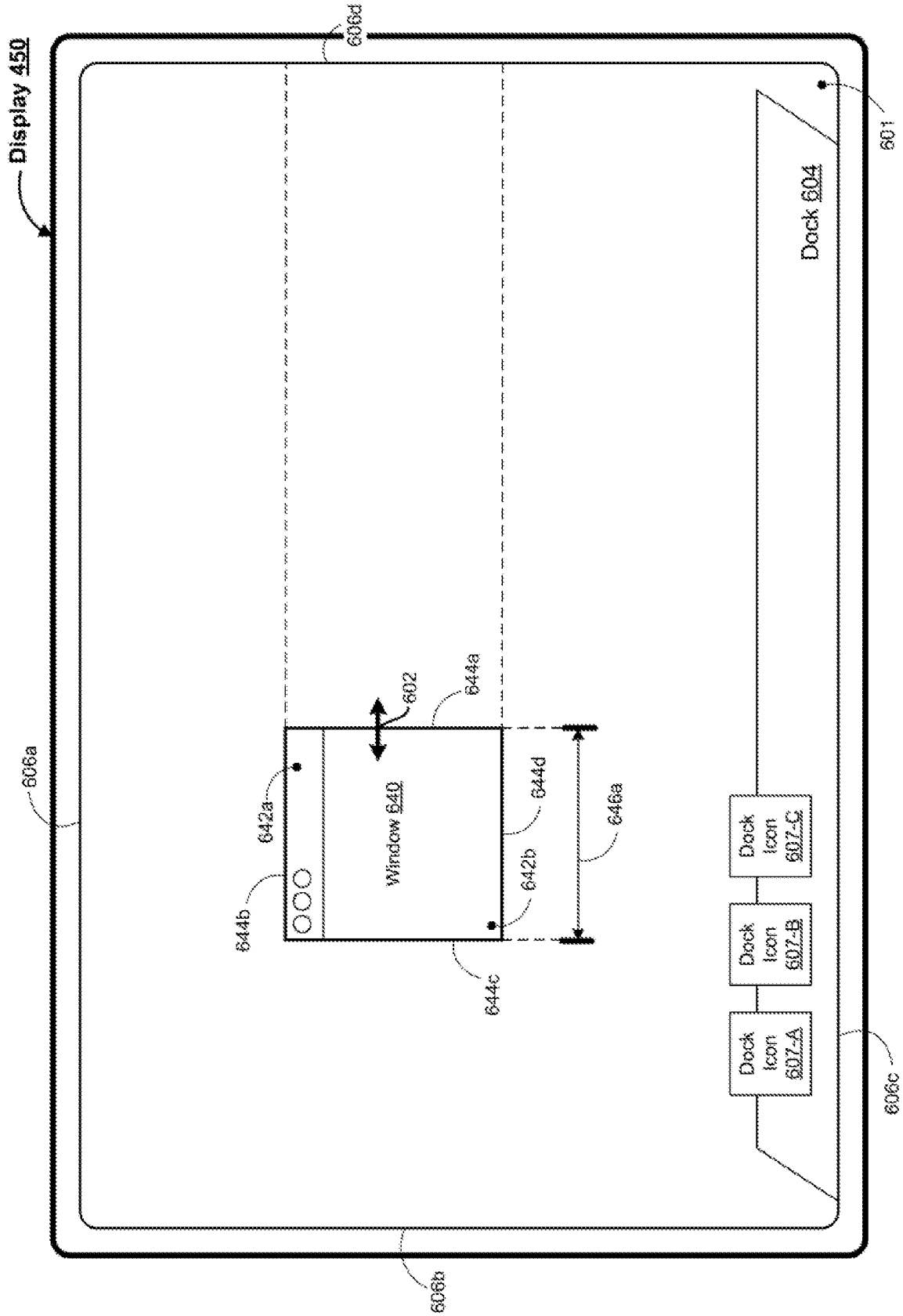

Figure 6L

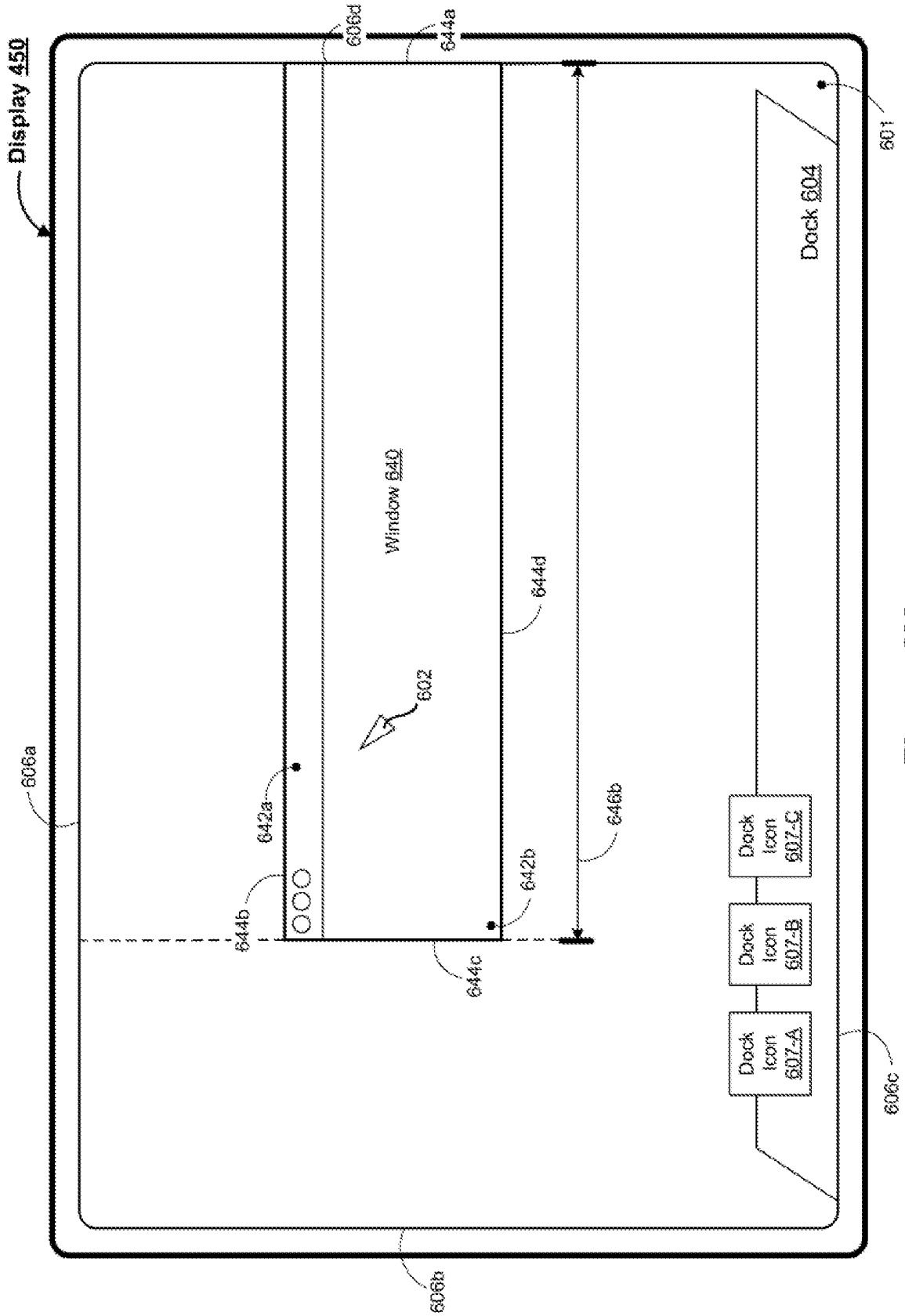

Figure 6M

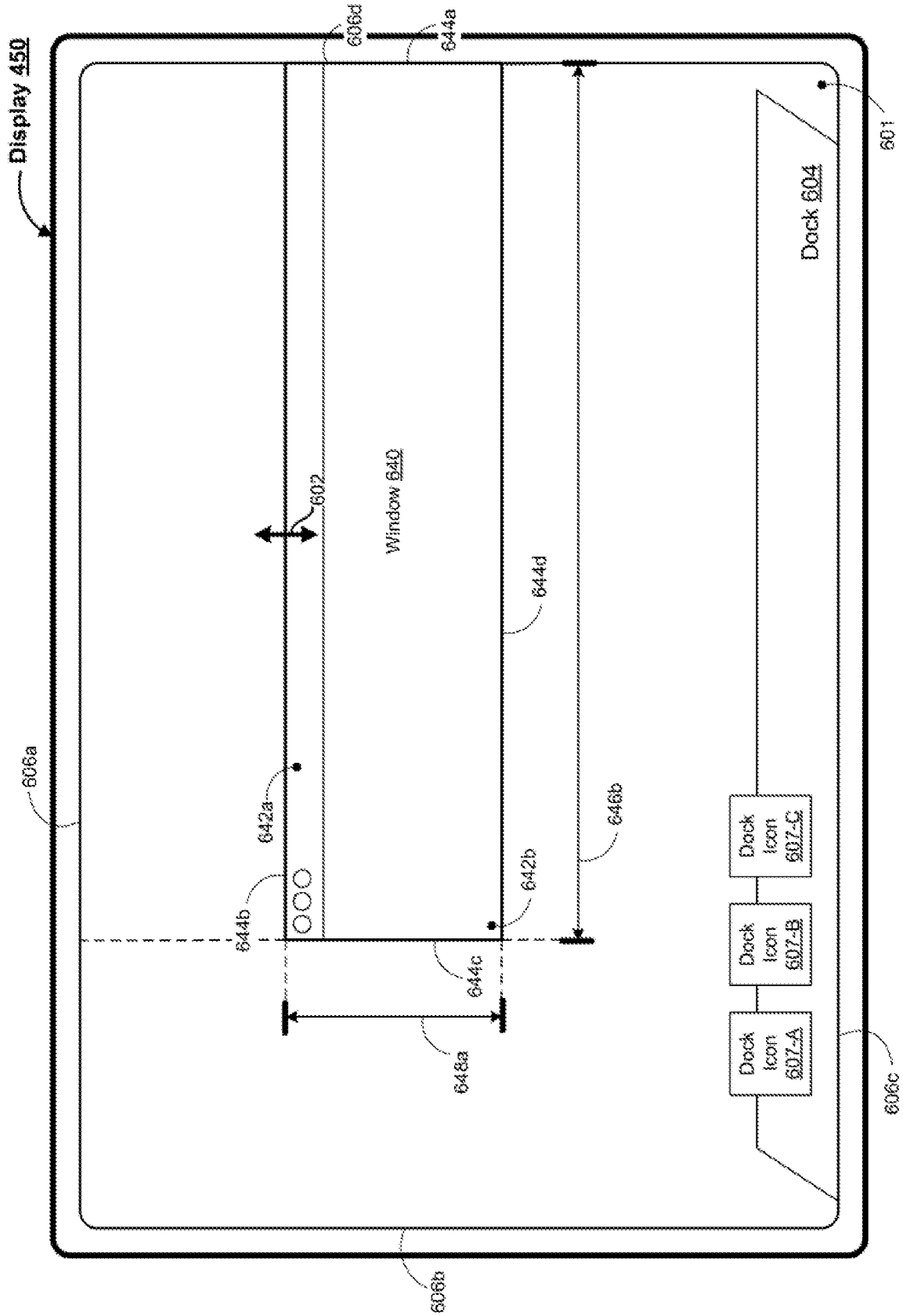

Figure 6N

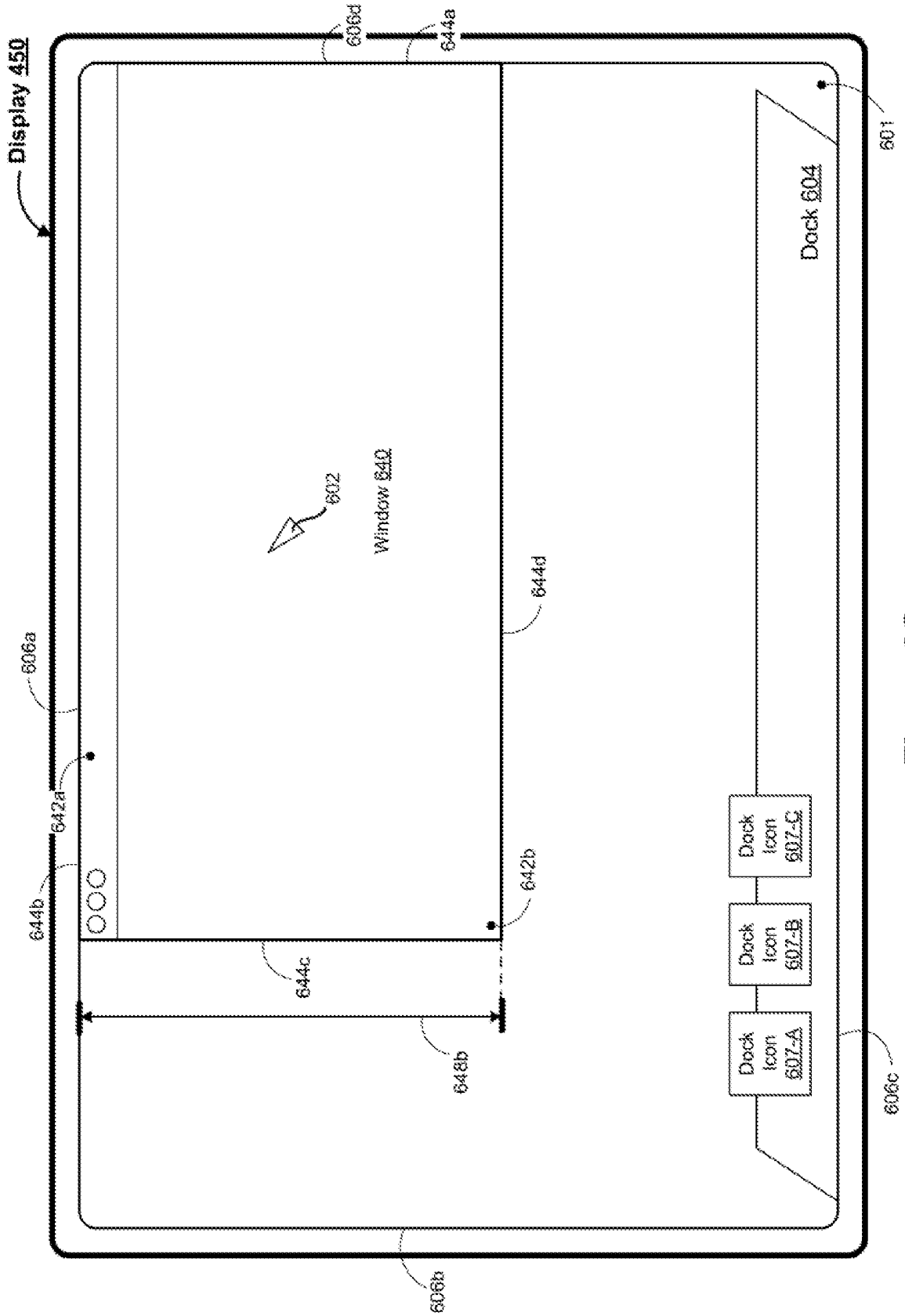

Figure 60



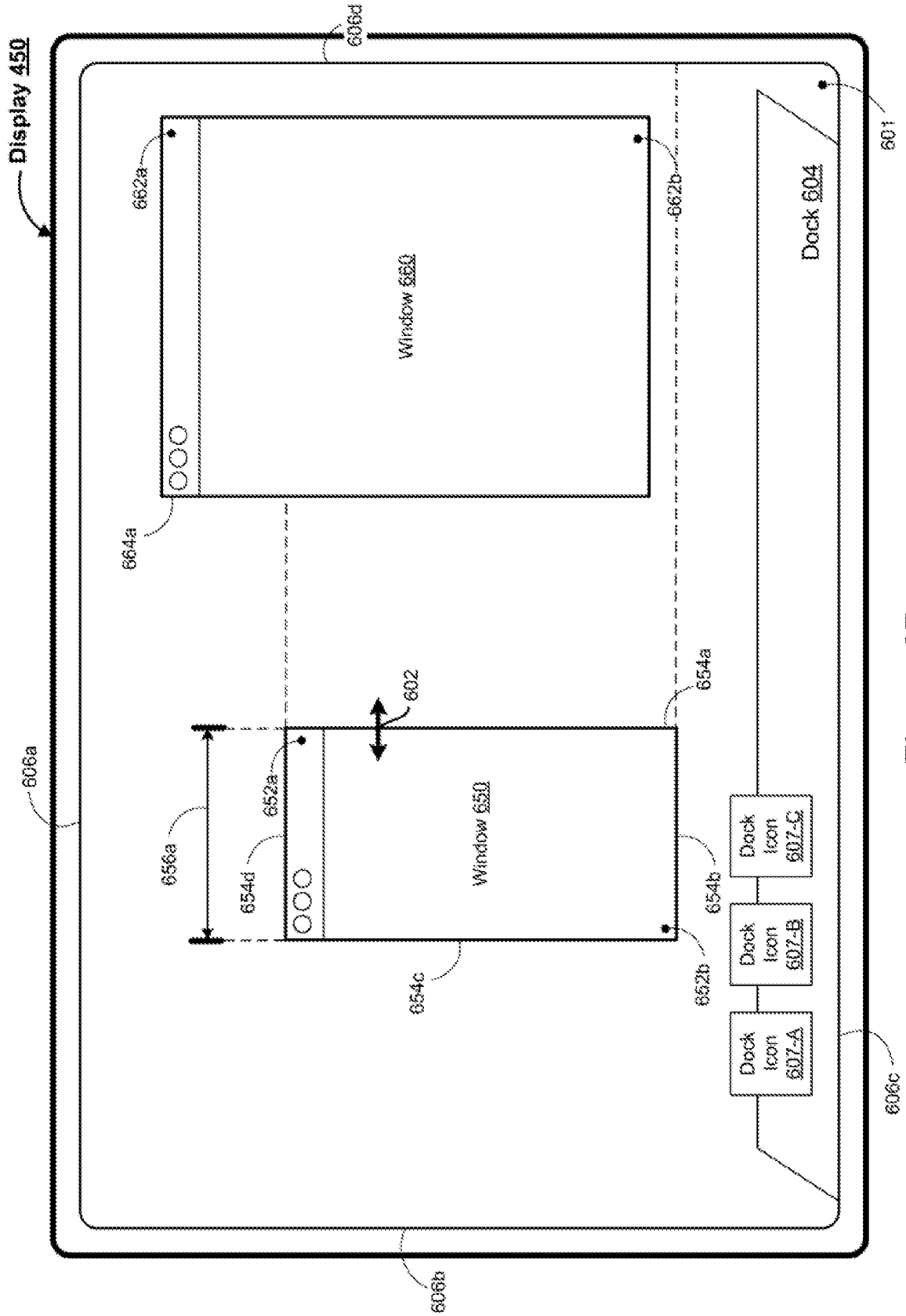

Figure 6P

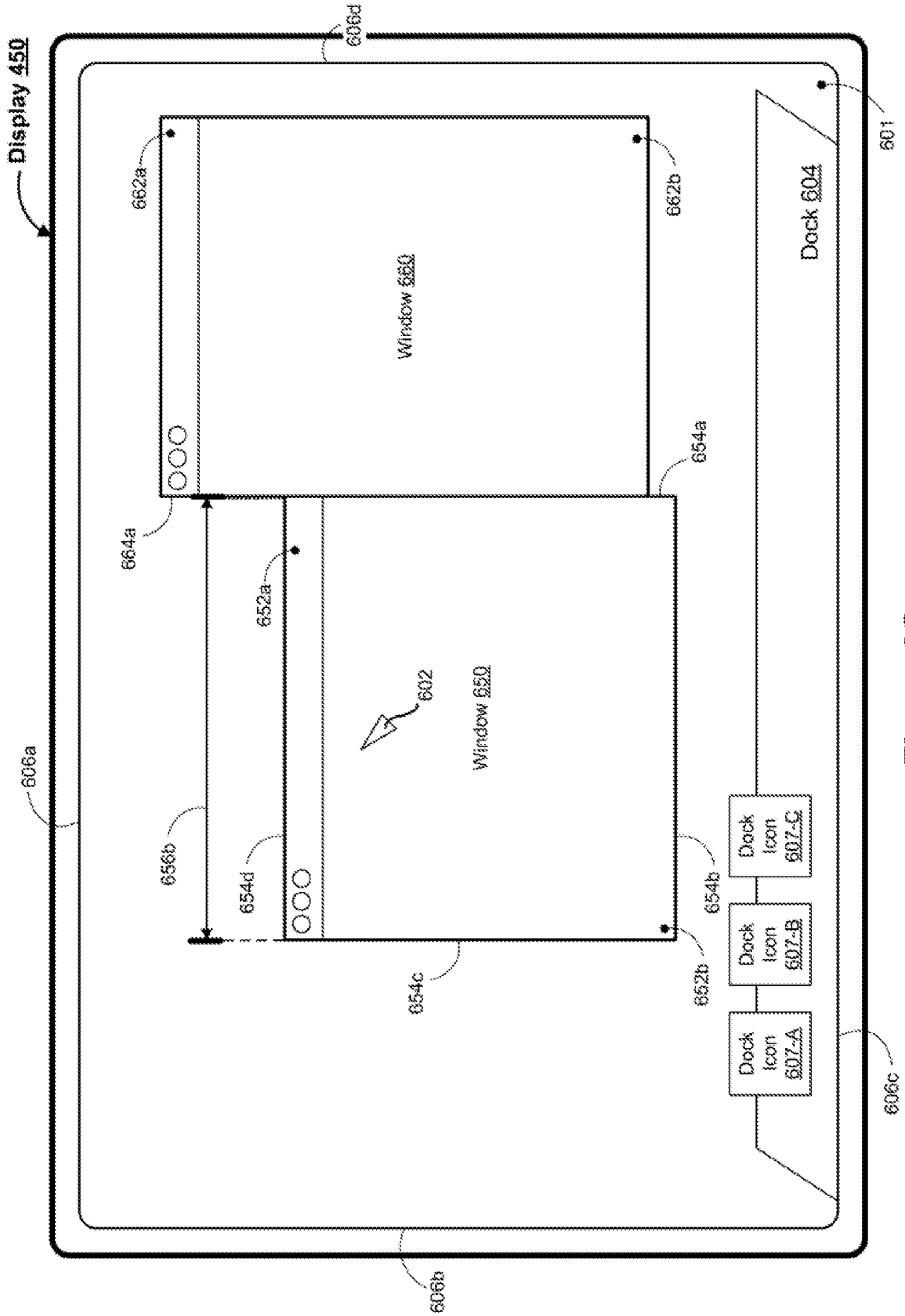

Figure 6Q

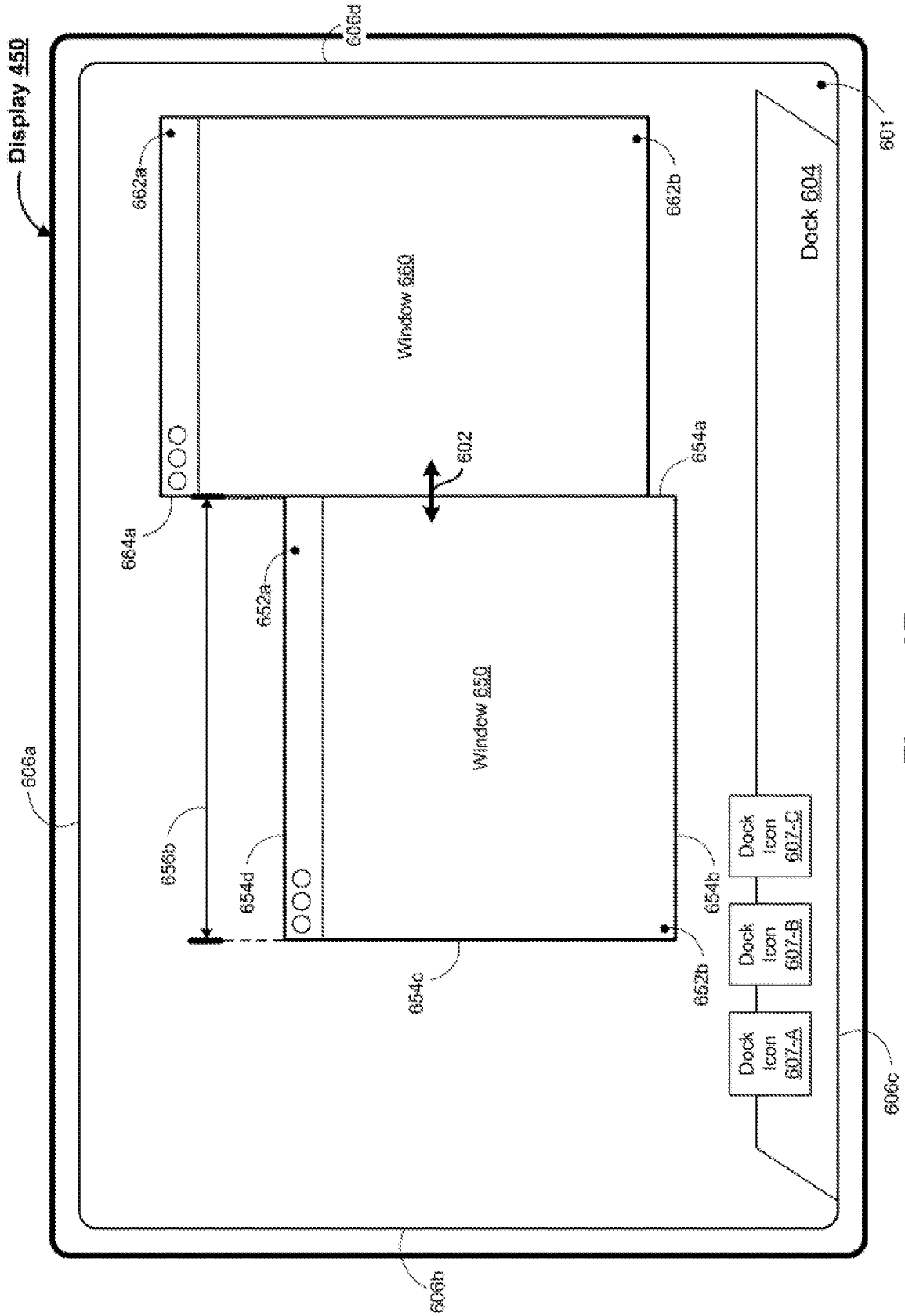

Figure 6R

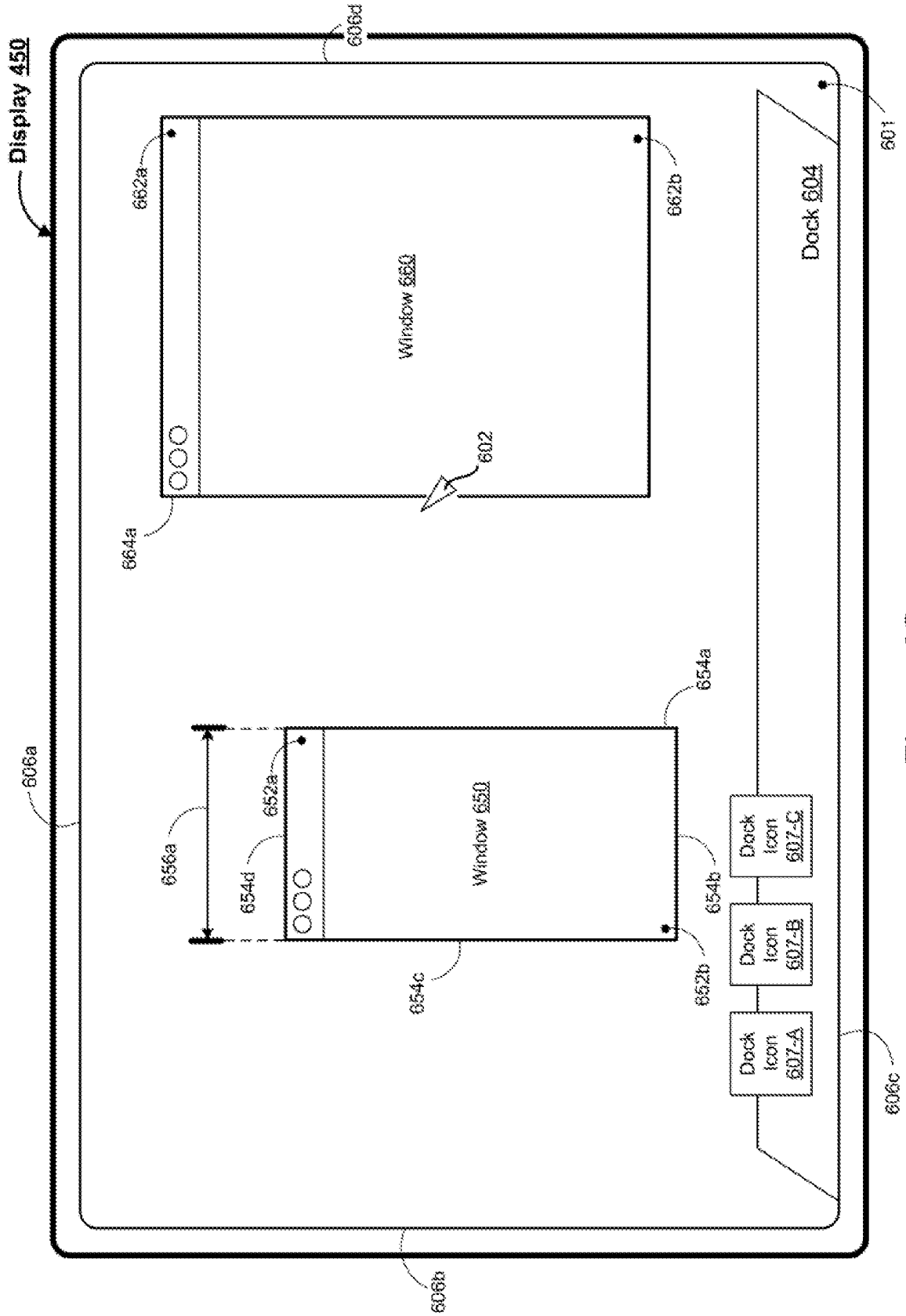

Figure 6S

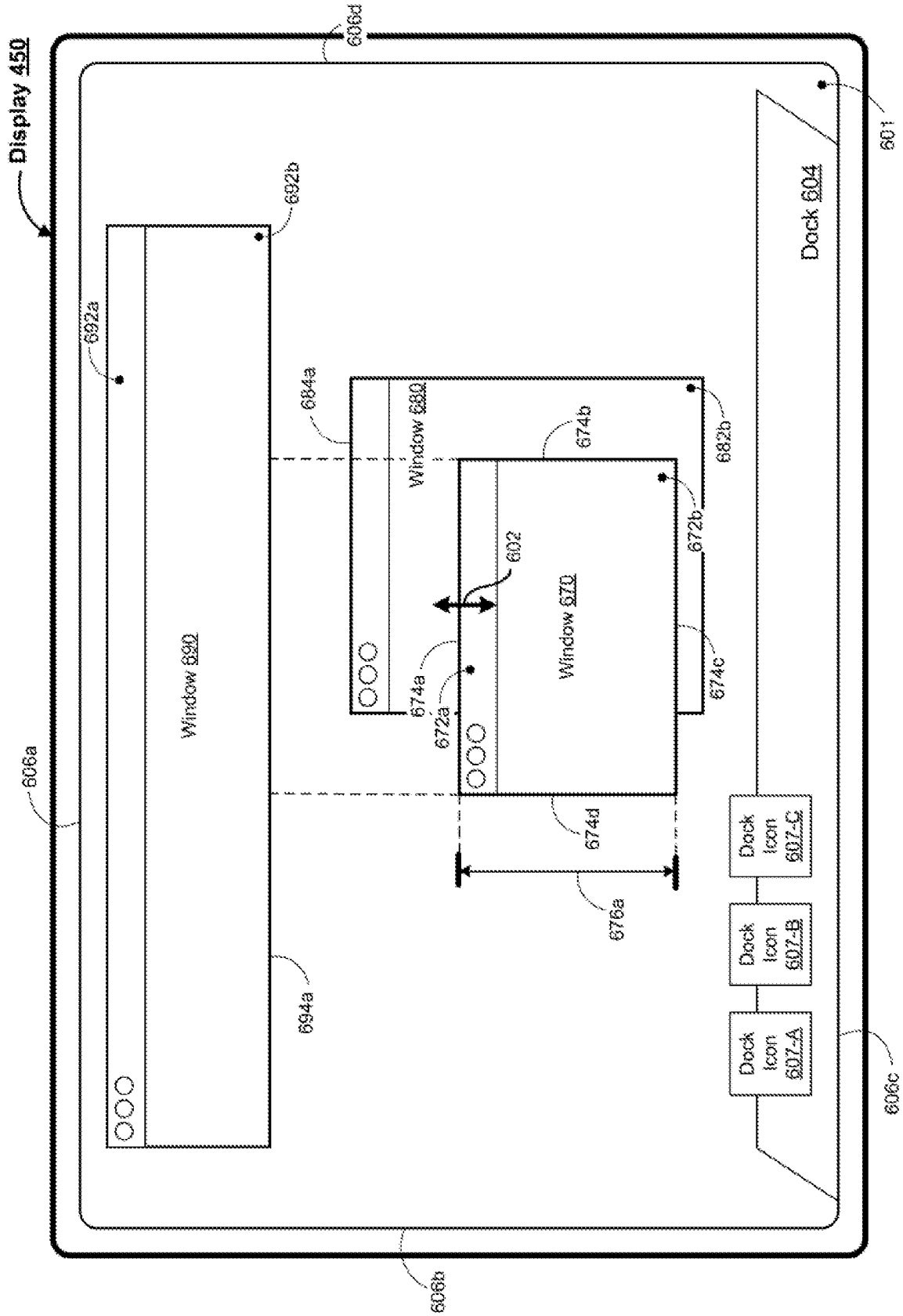

Figure 6T

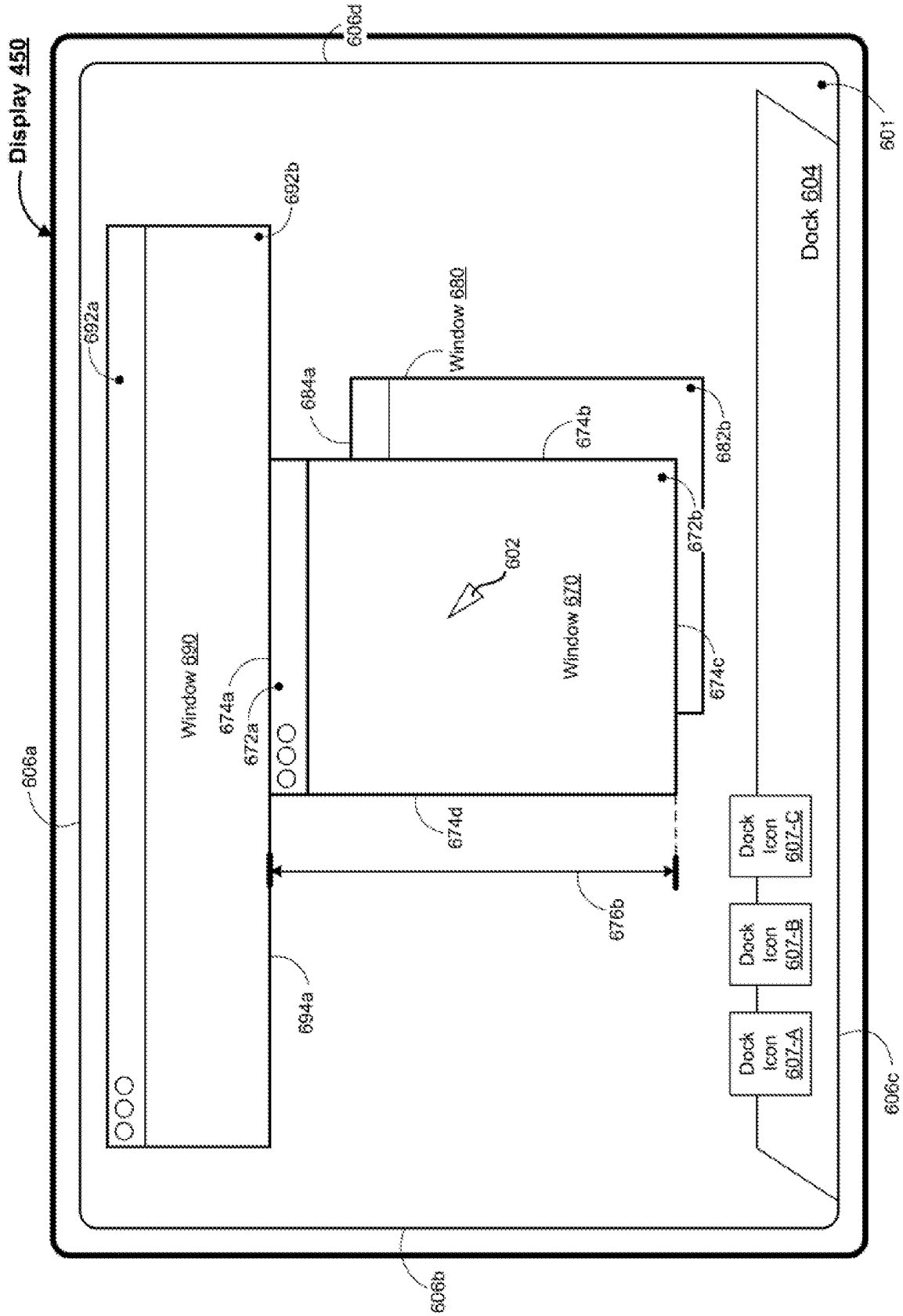

Figure 6U

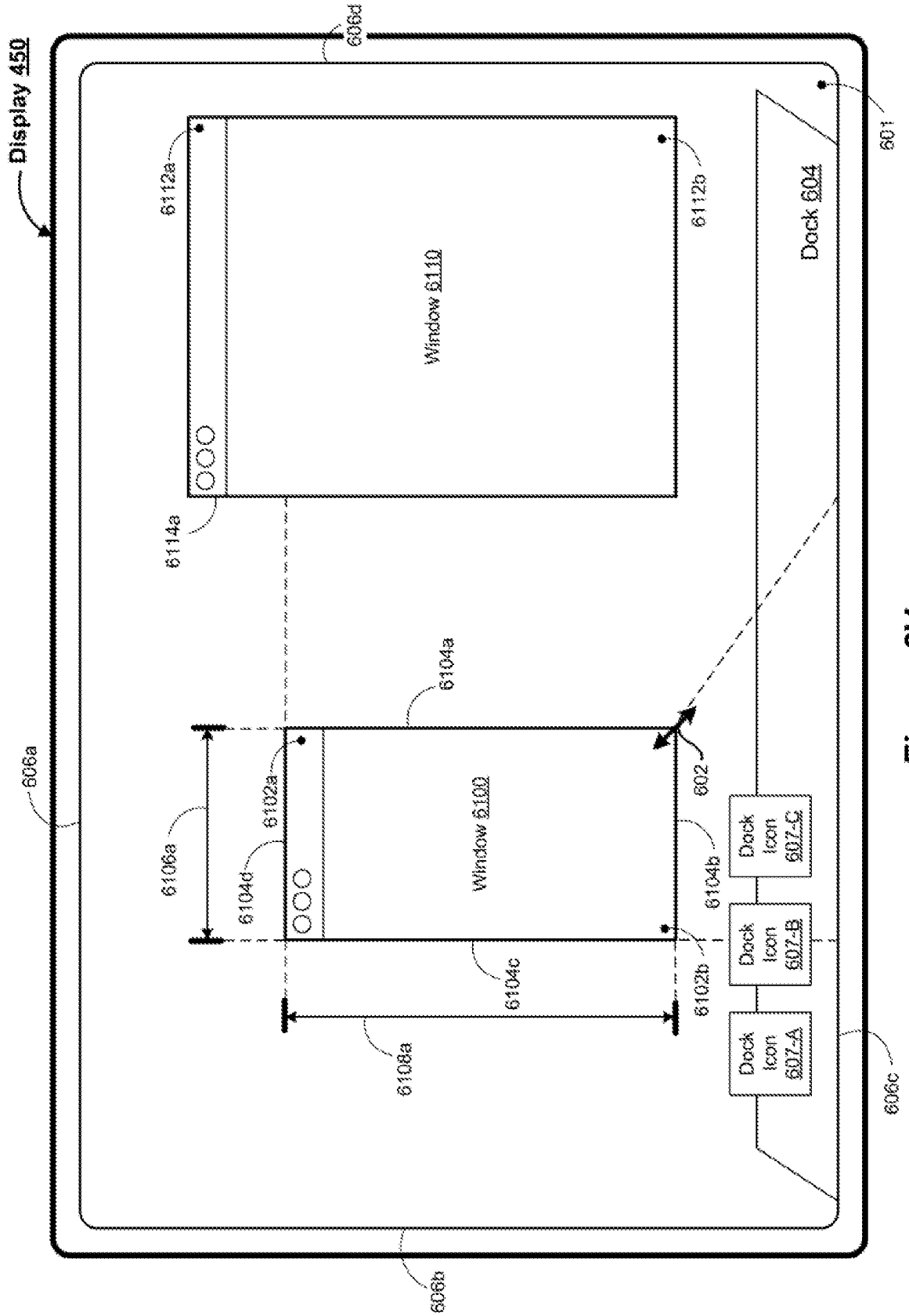

Figure 6V

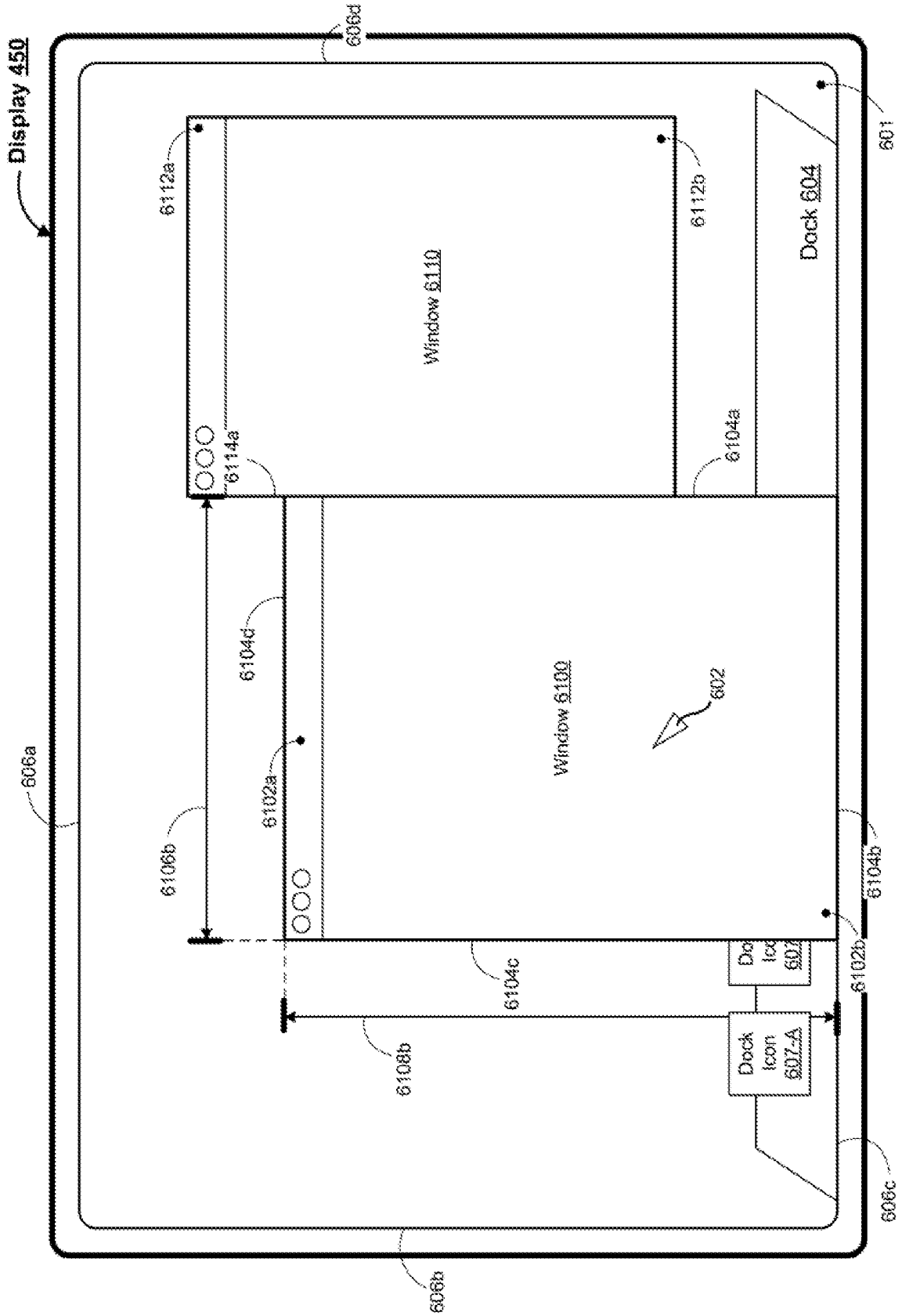

Figure 6W



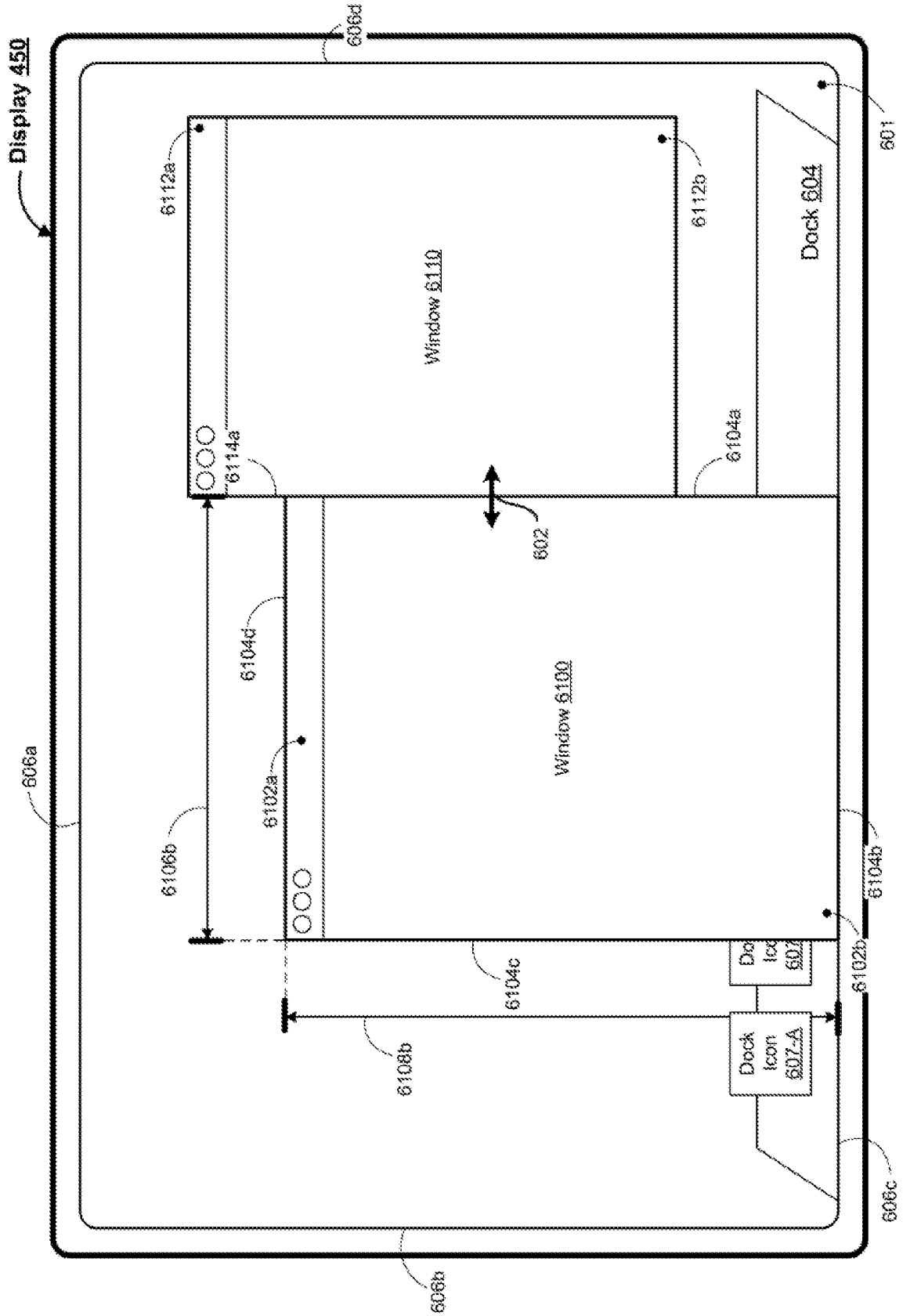

Figure 6X

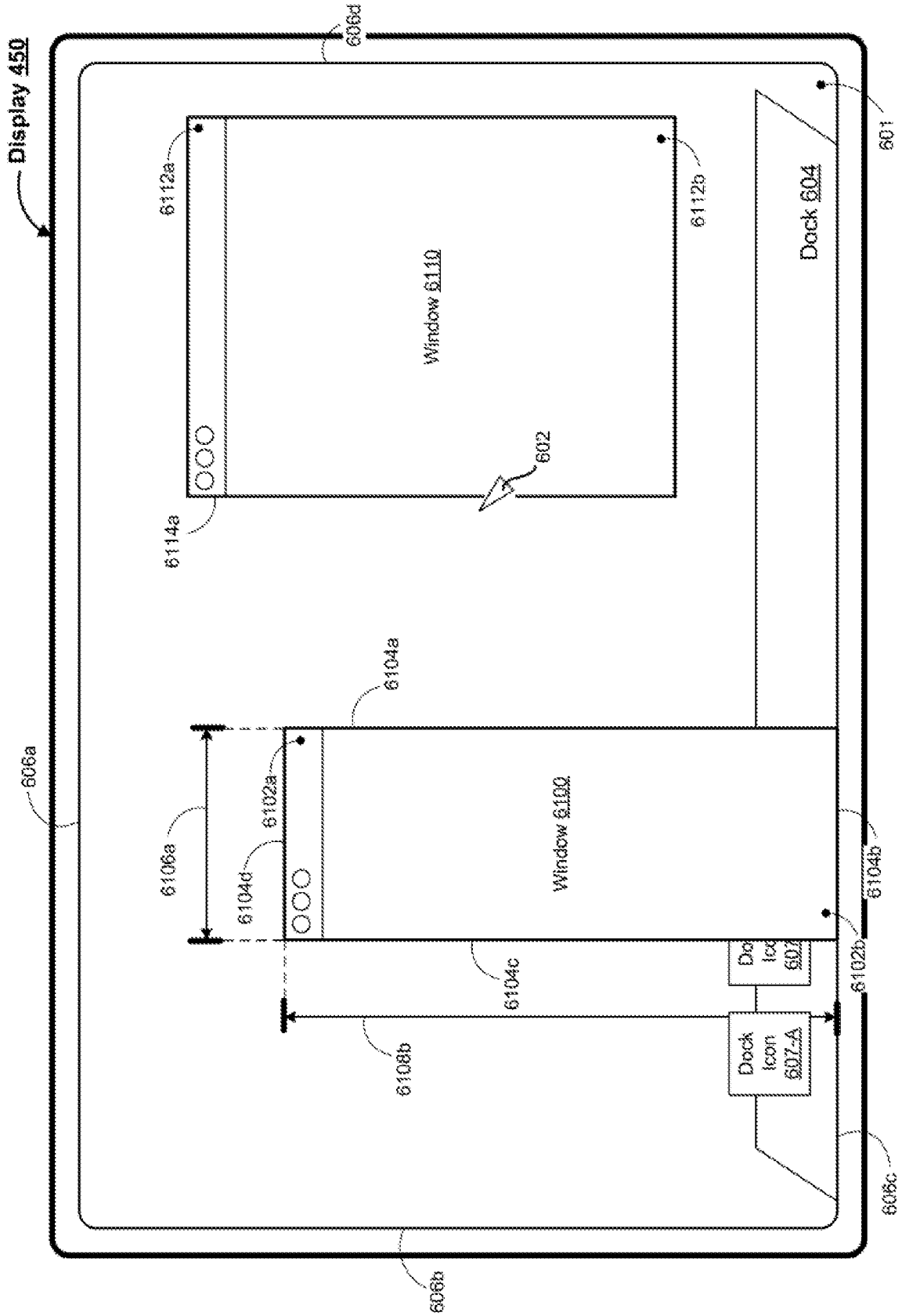

Figure 6Y

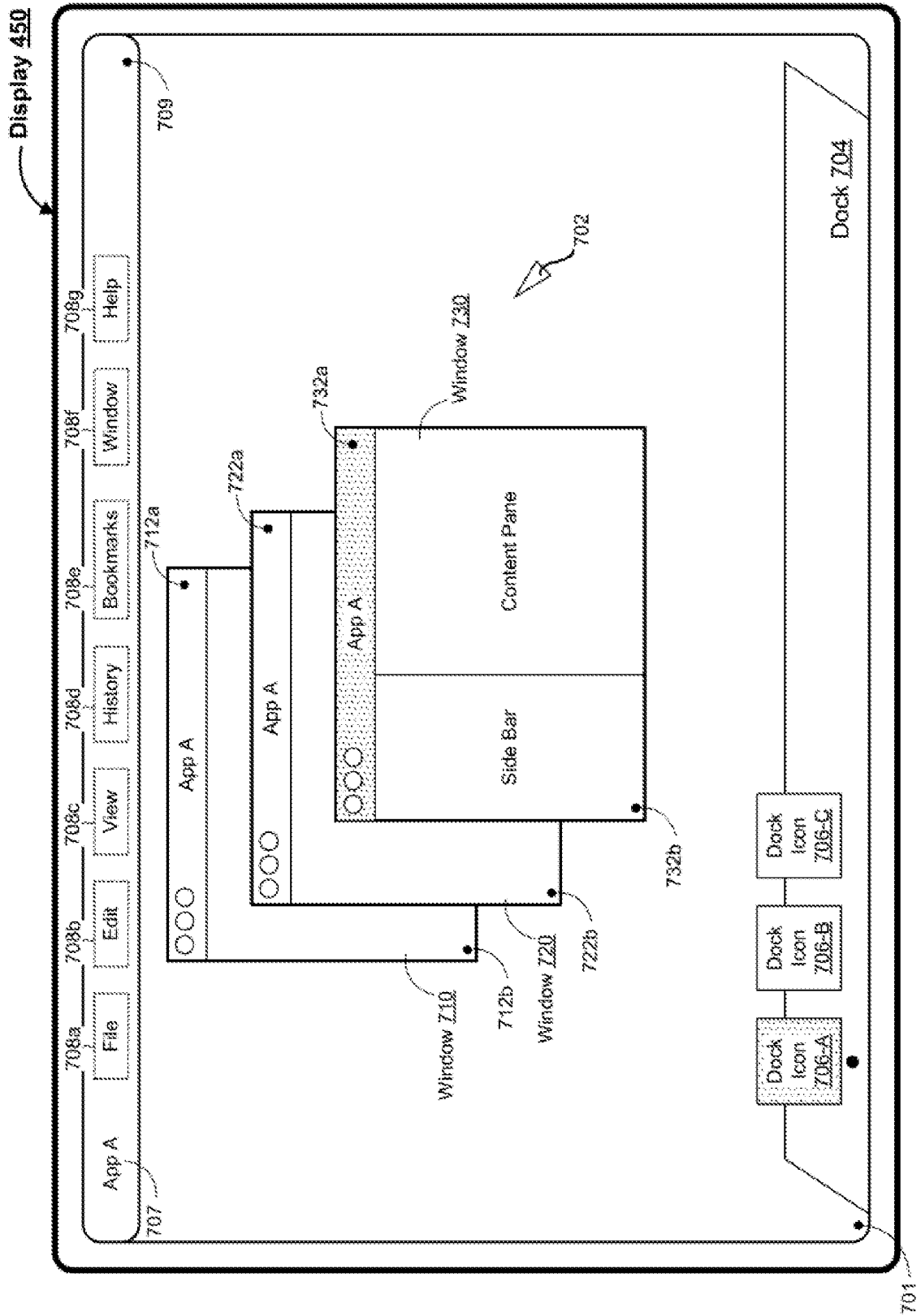

Figure 7A

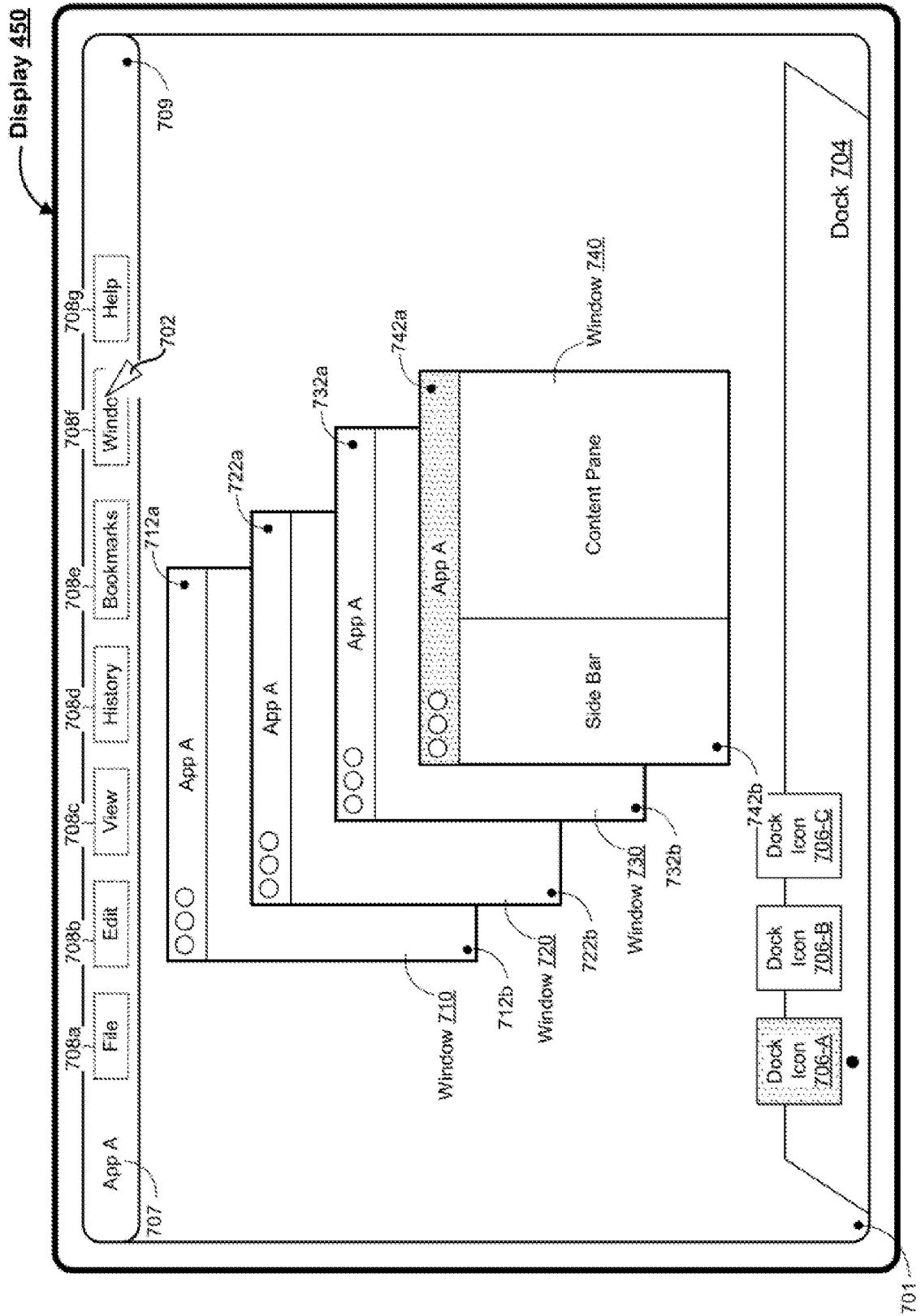

Figure 7B

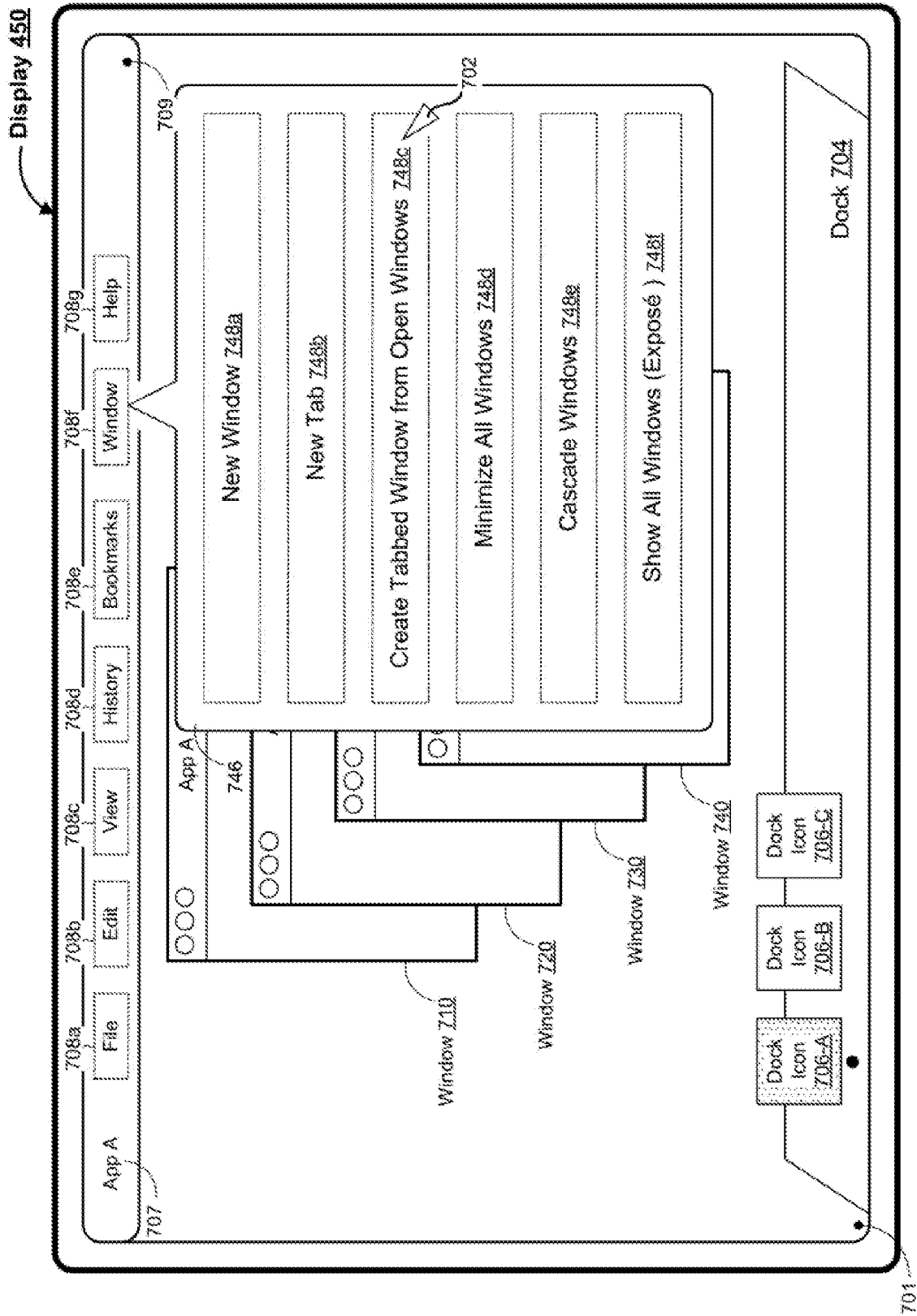

Figure 7C

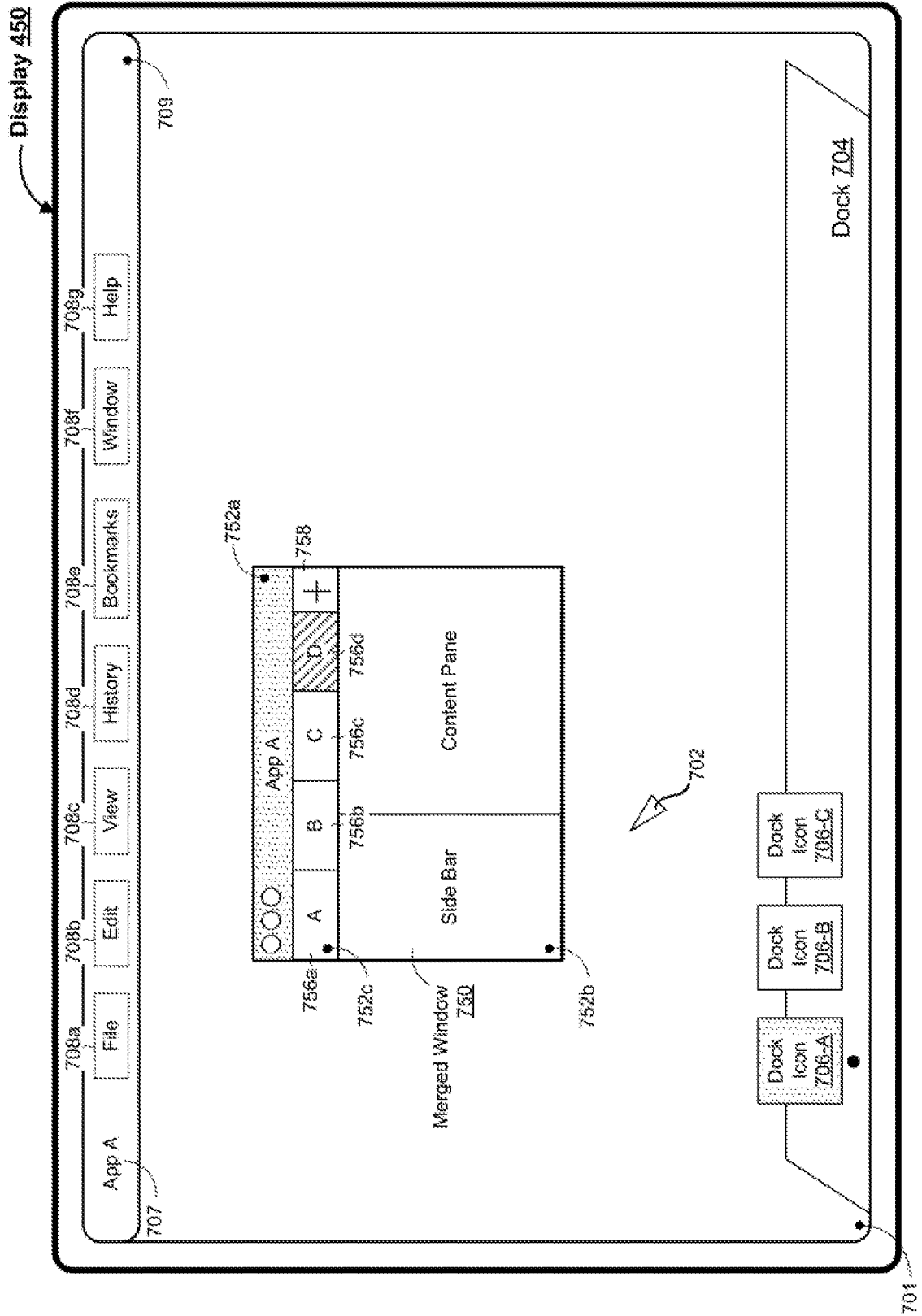

Figure 7D

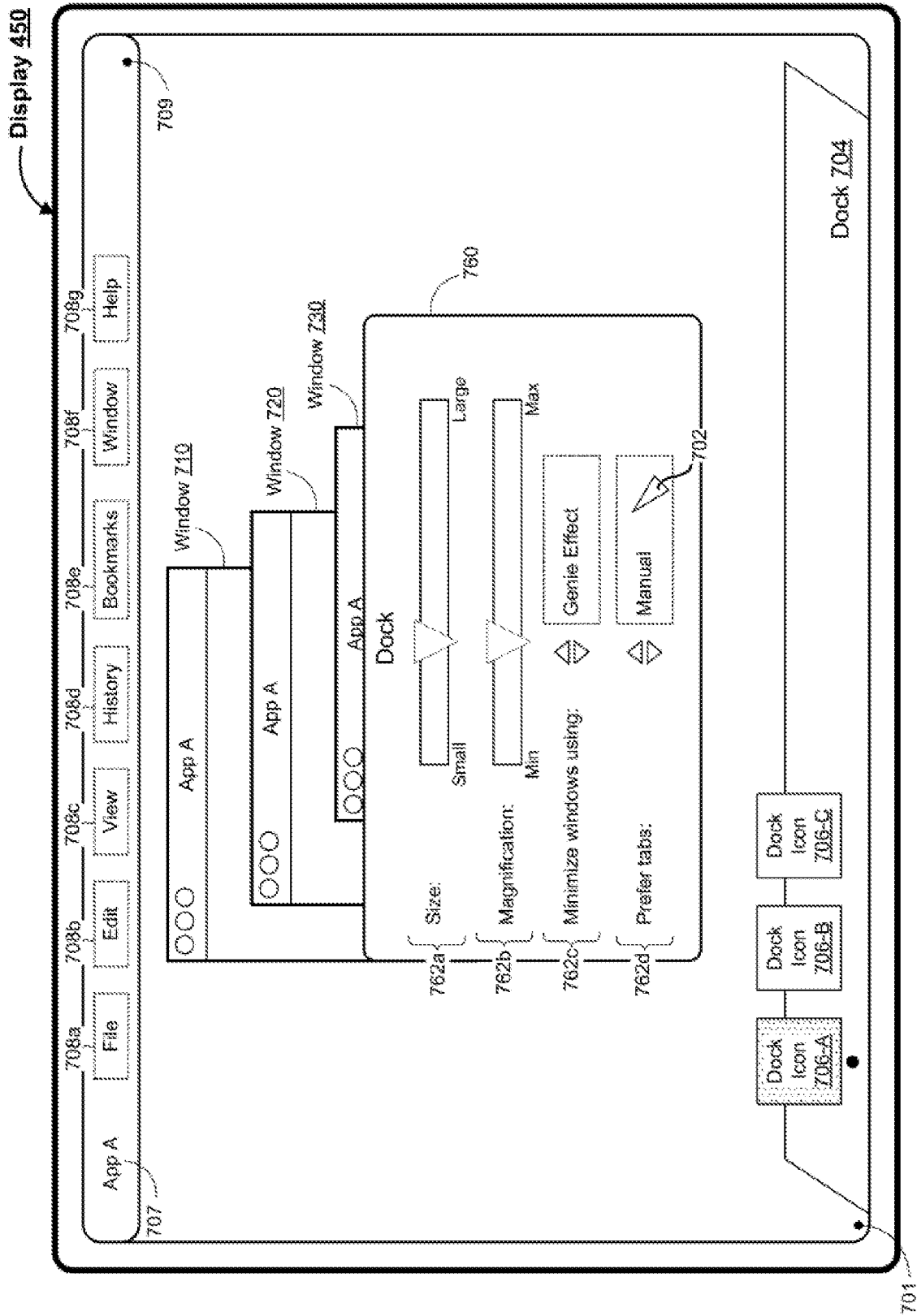

Figure 7E

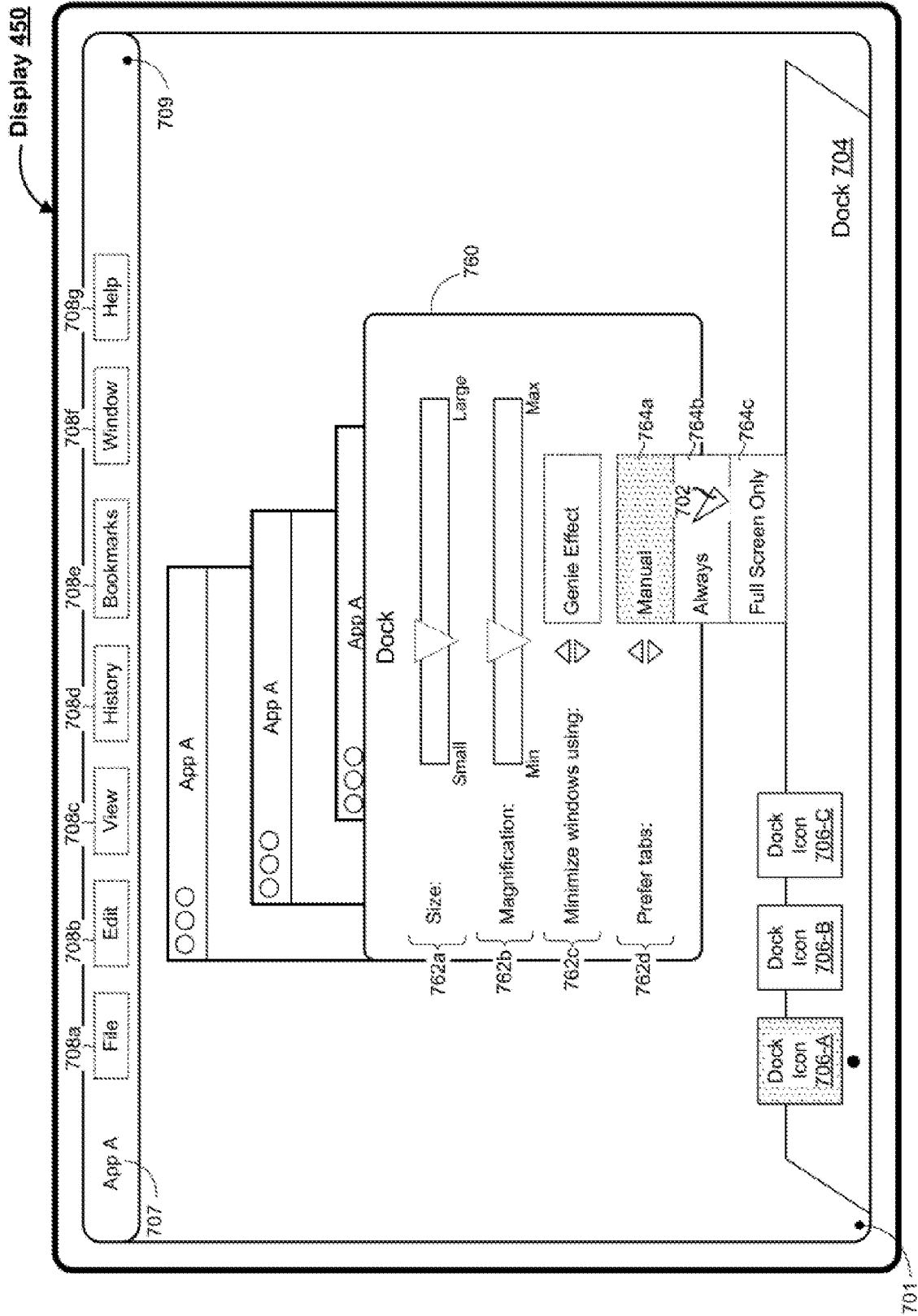

Figure 7F



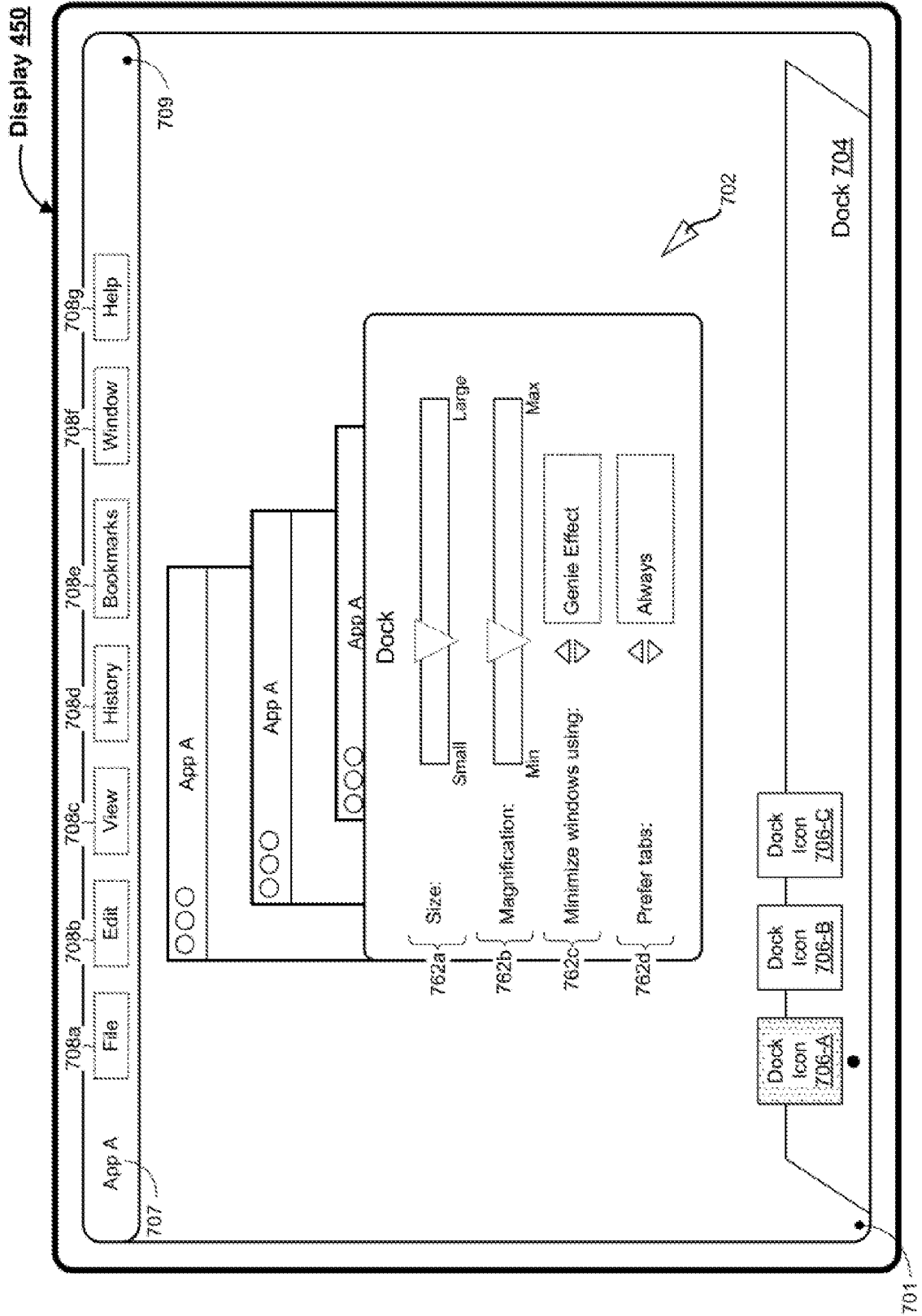

Figure 7G

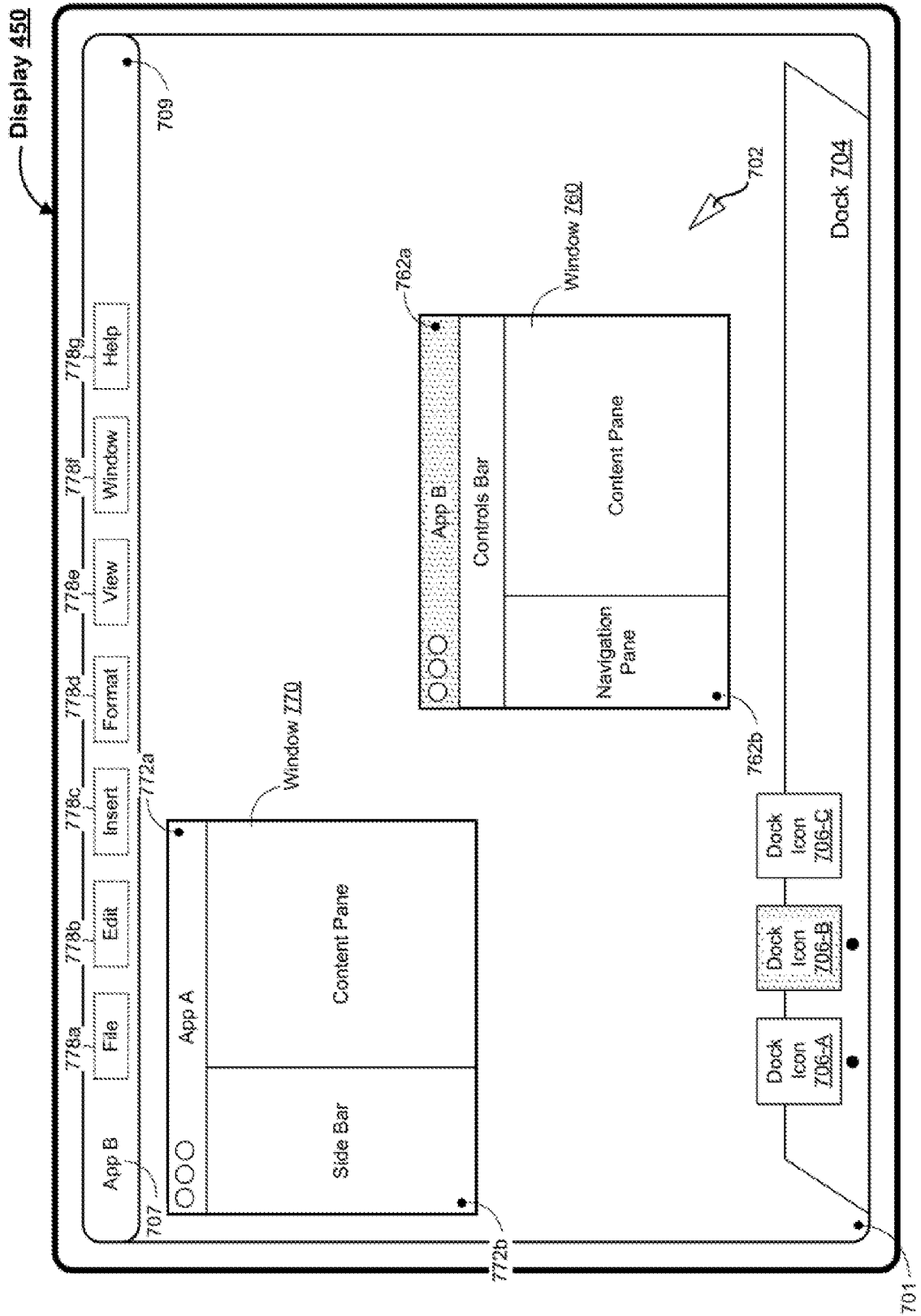

Figure 7H

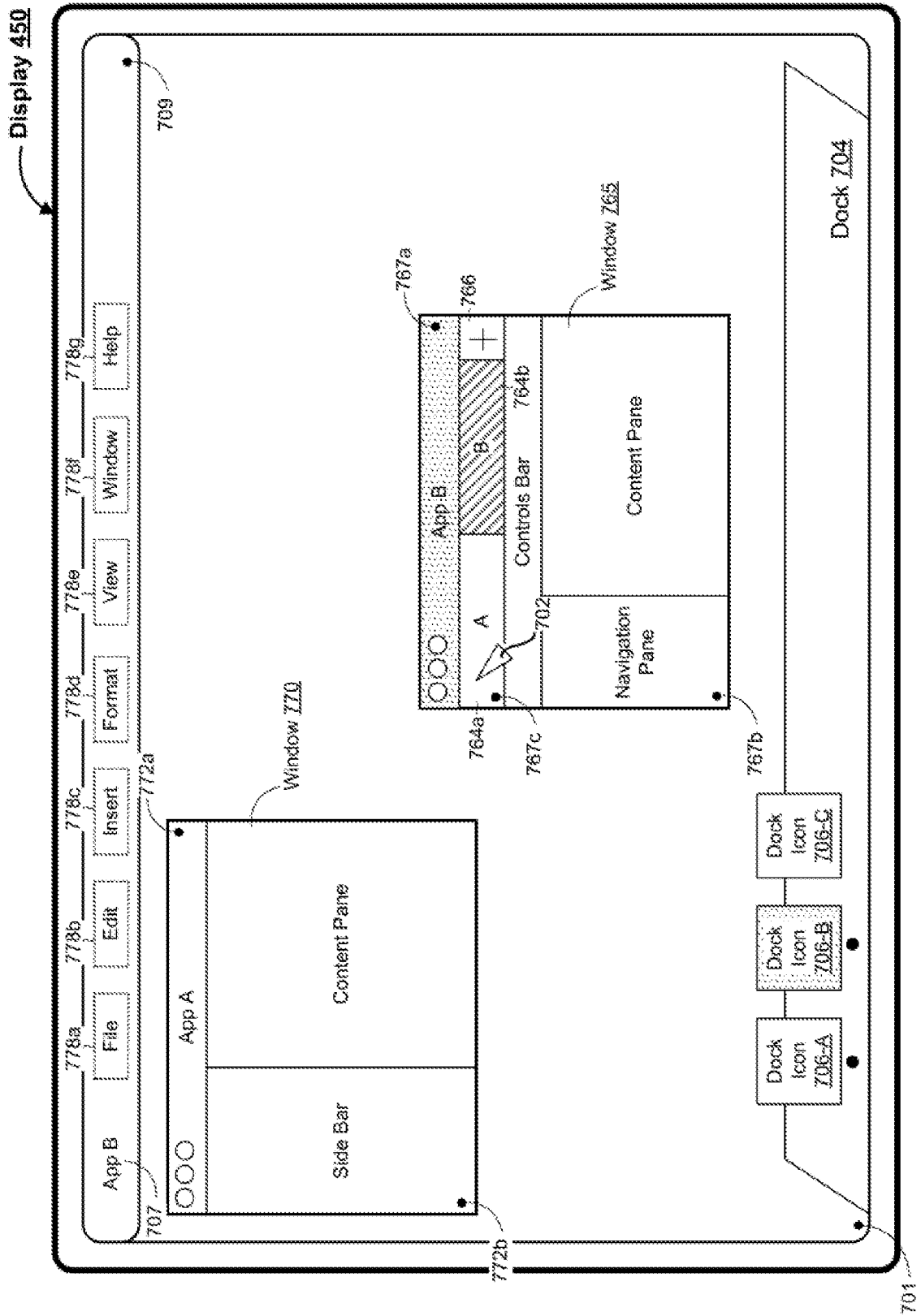

Figure 71

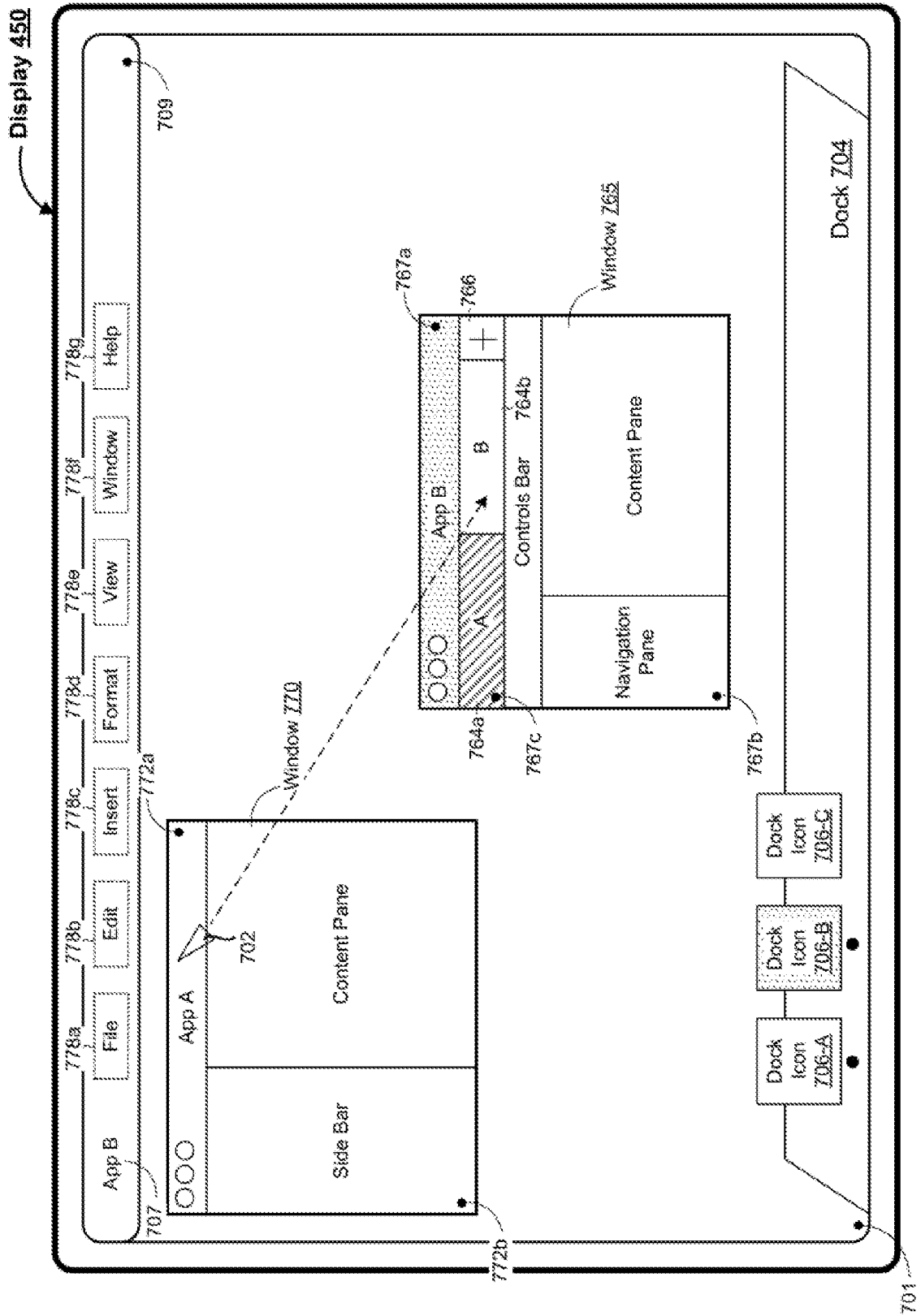

Figure 7J

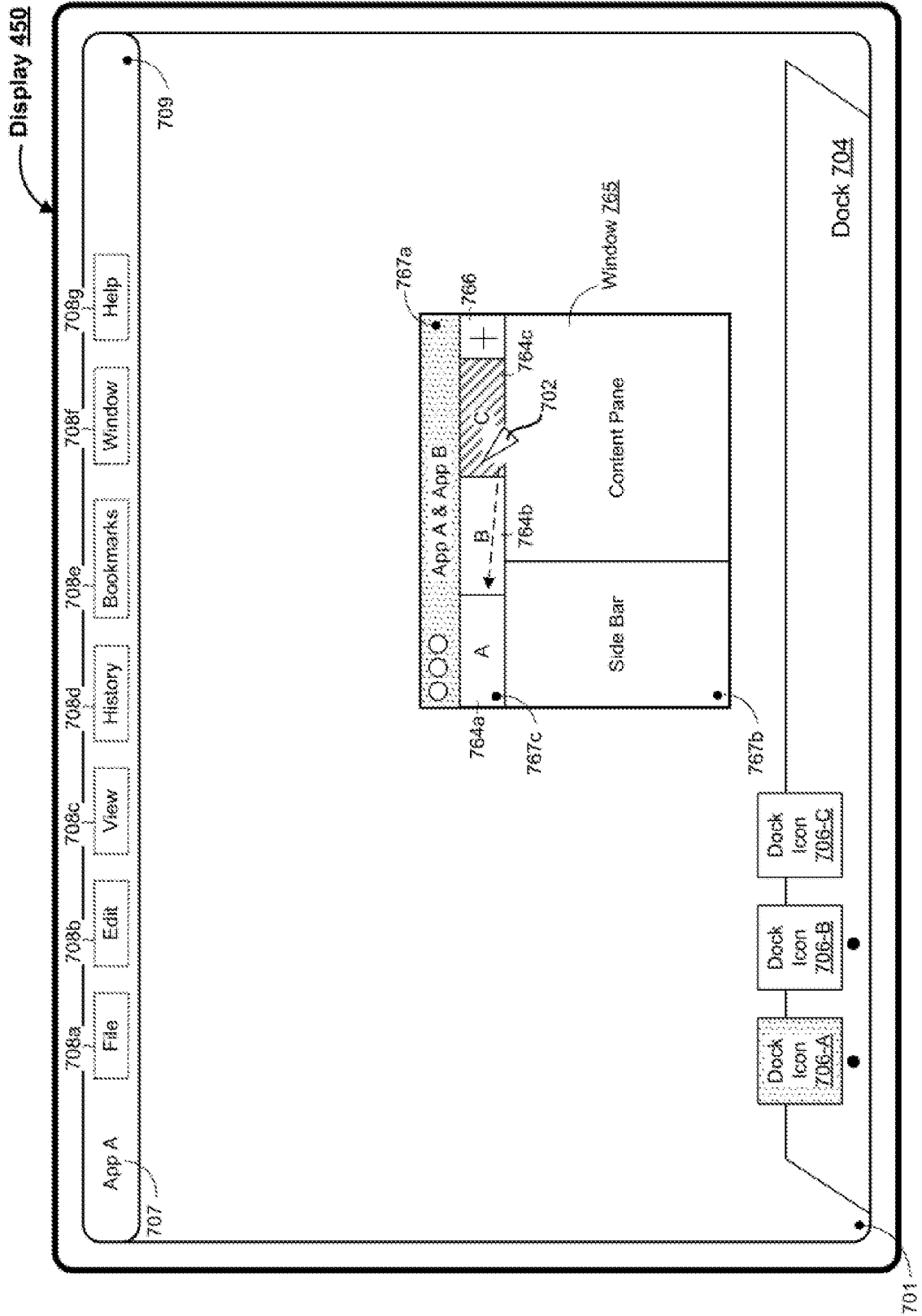

Figure 7K

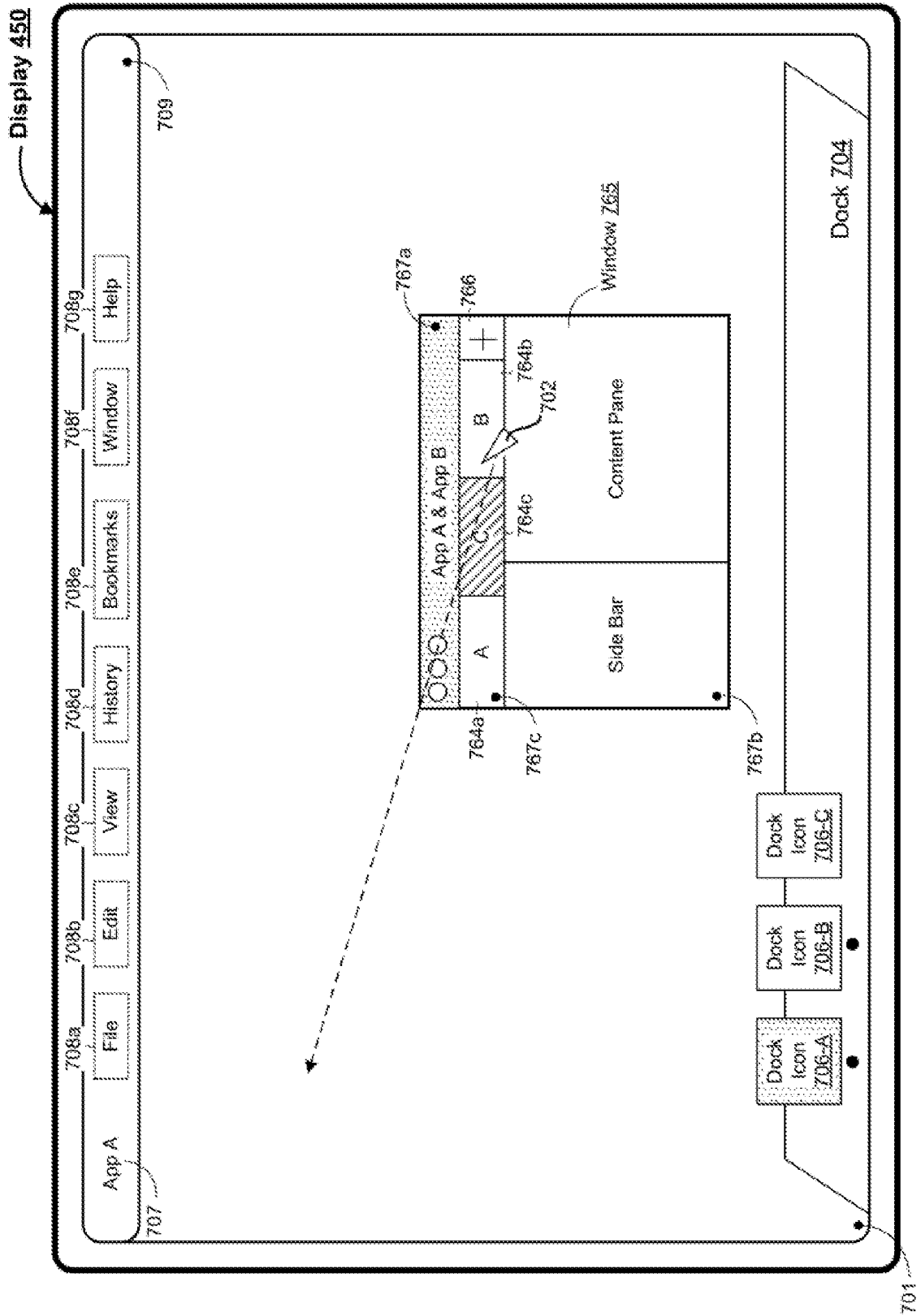

Figure 7L

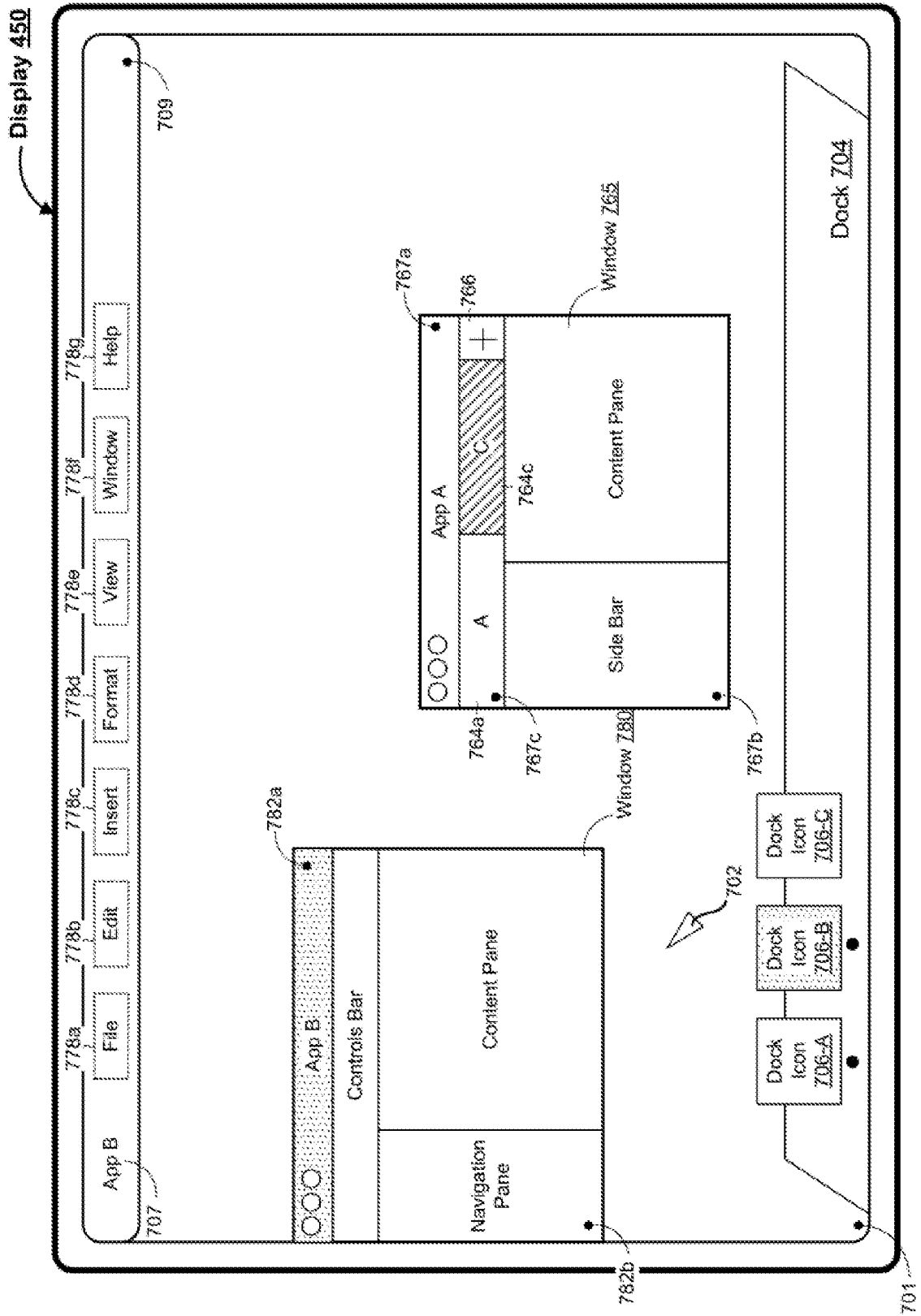

Figure 7M

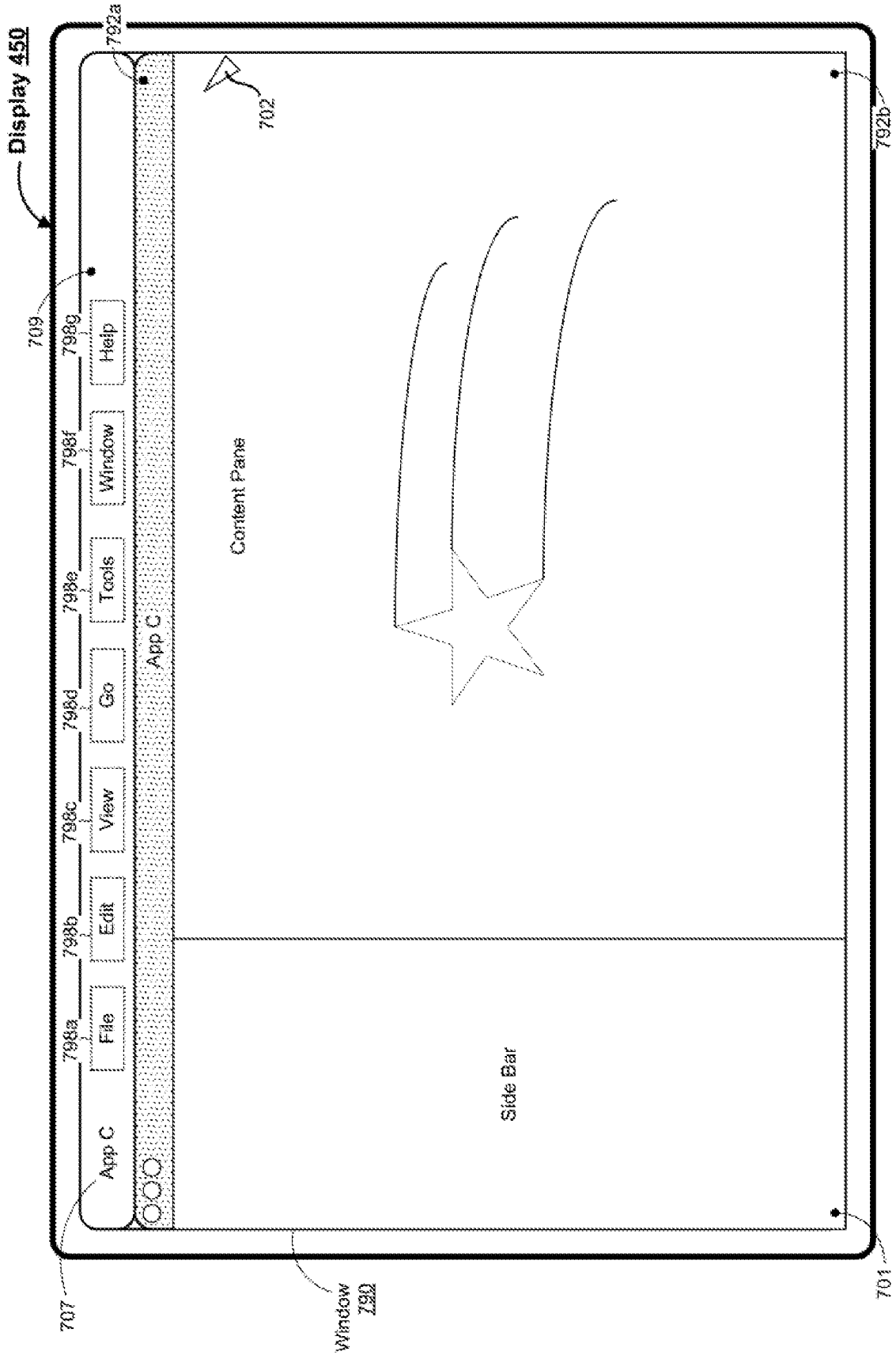

Figure 7N



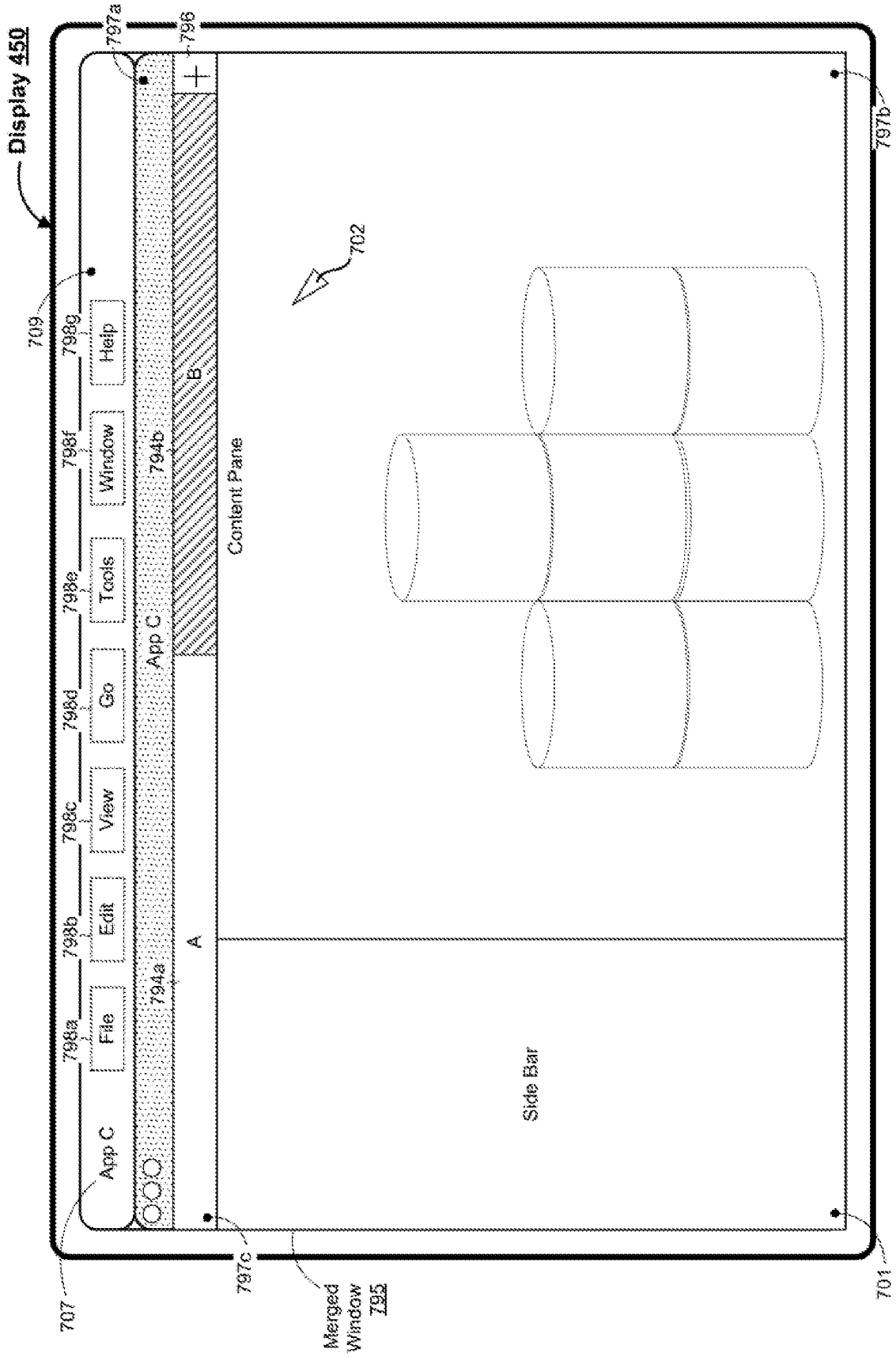

Figure 70

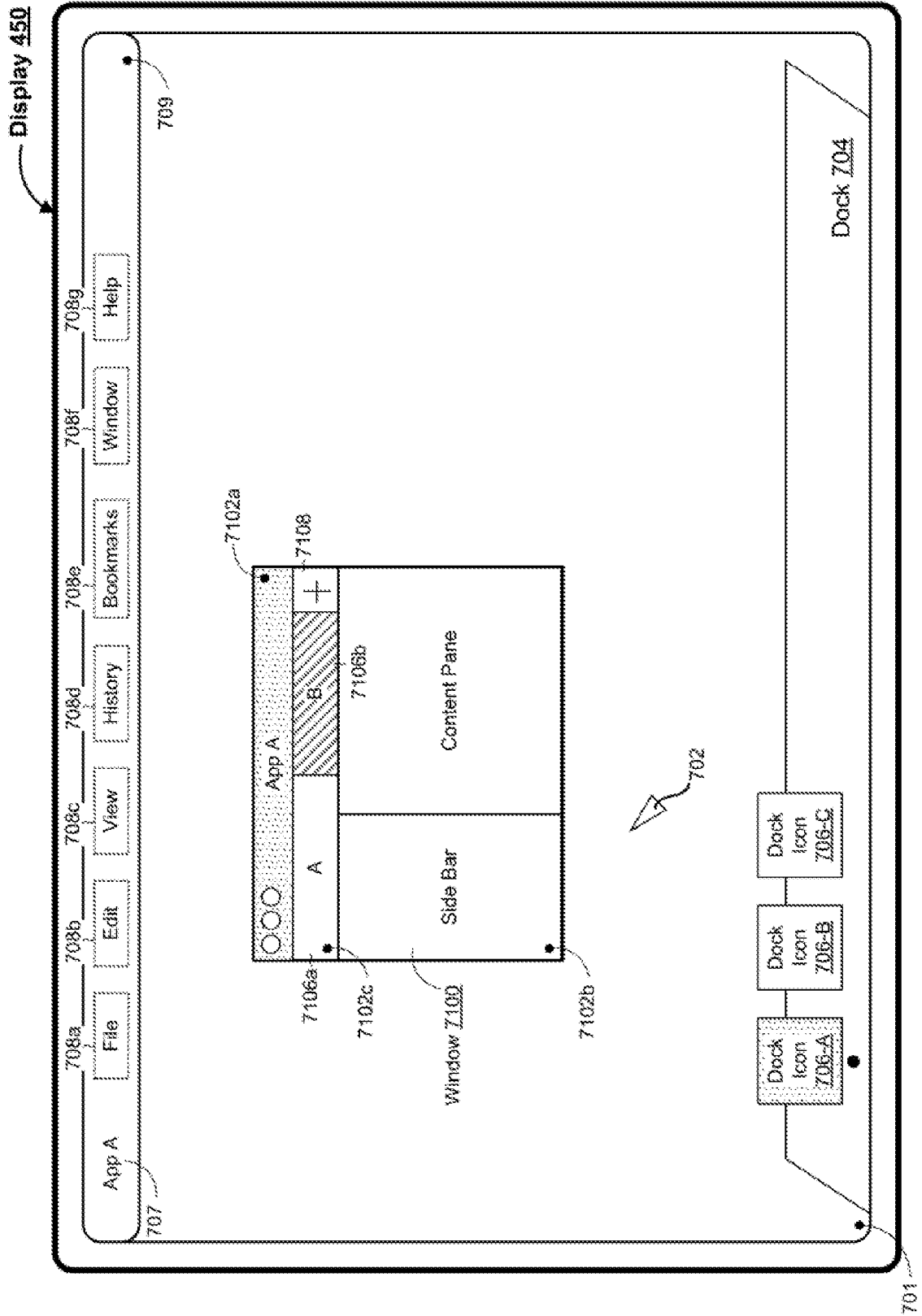

Figure 7P

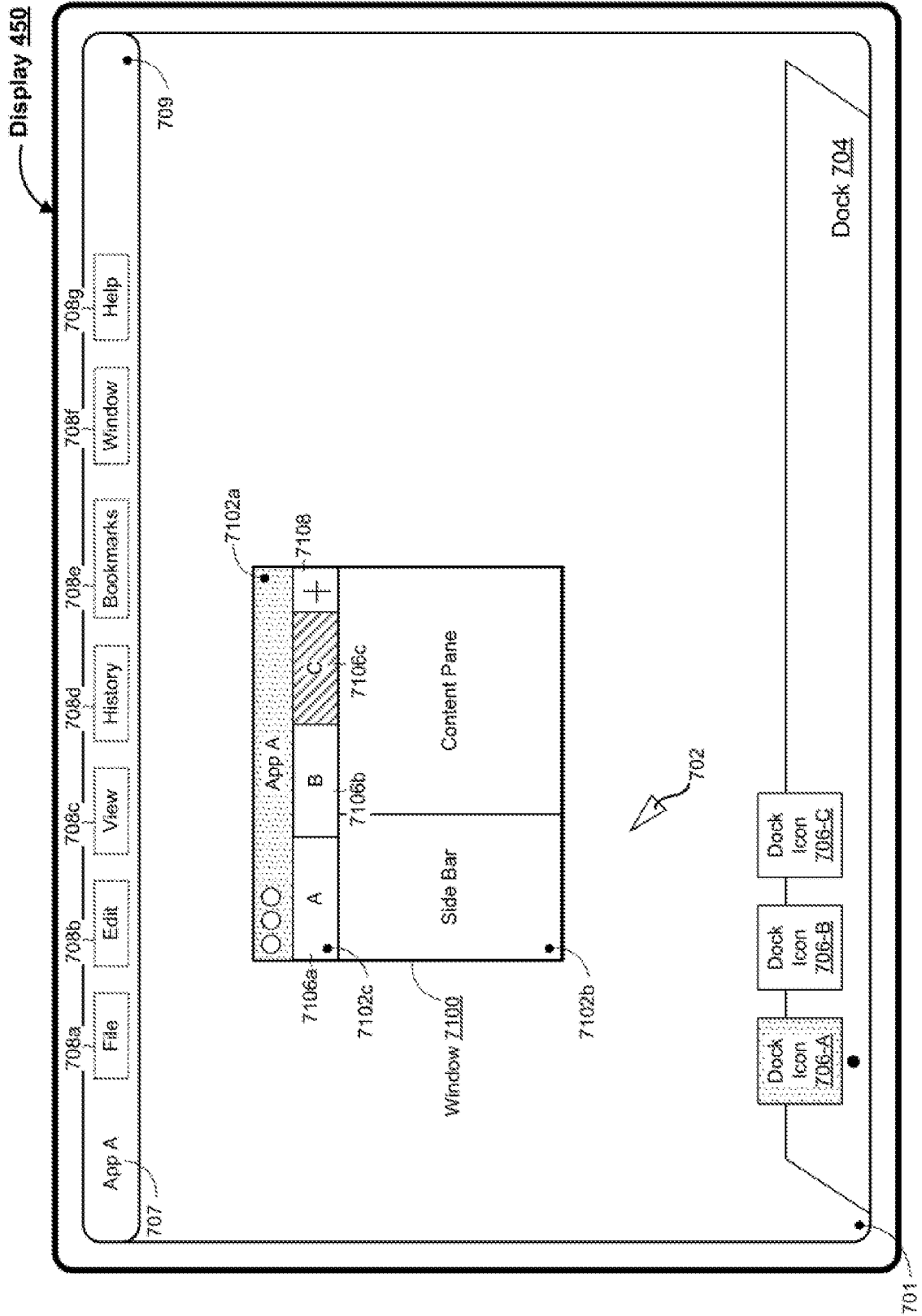

Figure 7Q

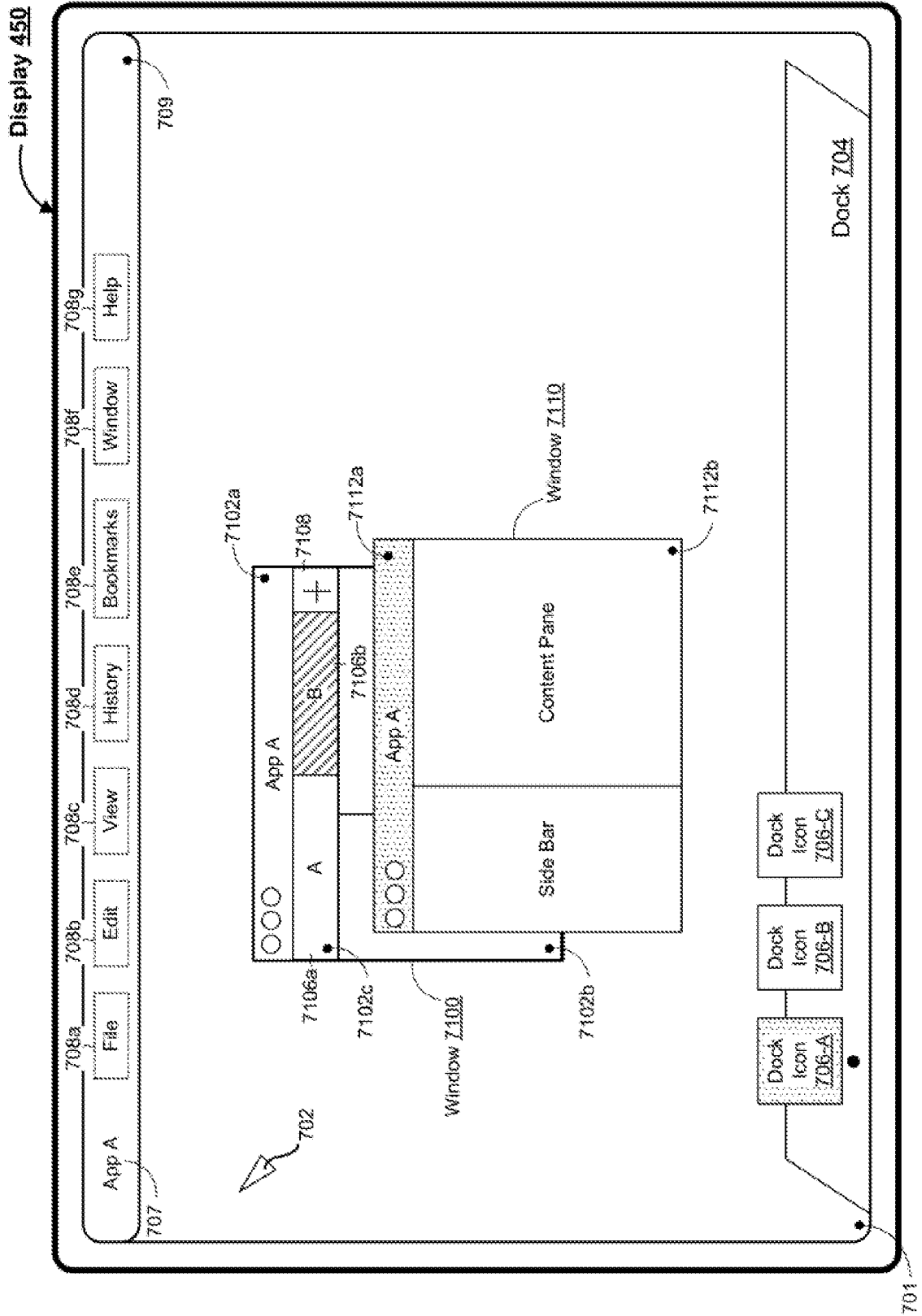

Figure 7R

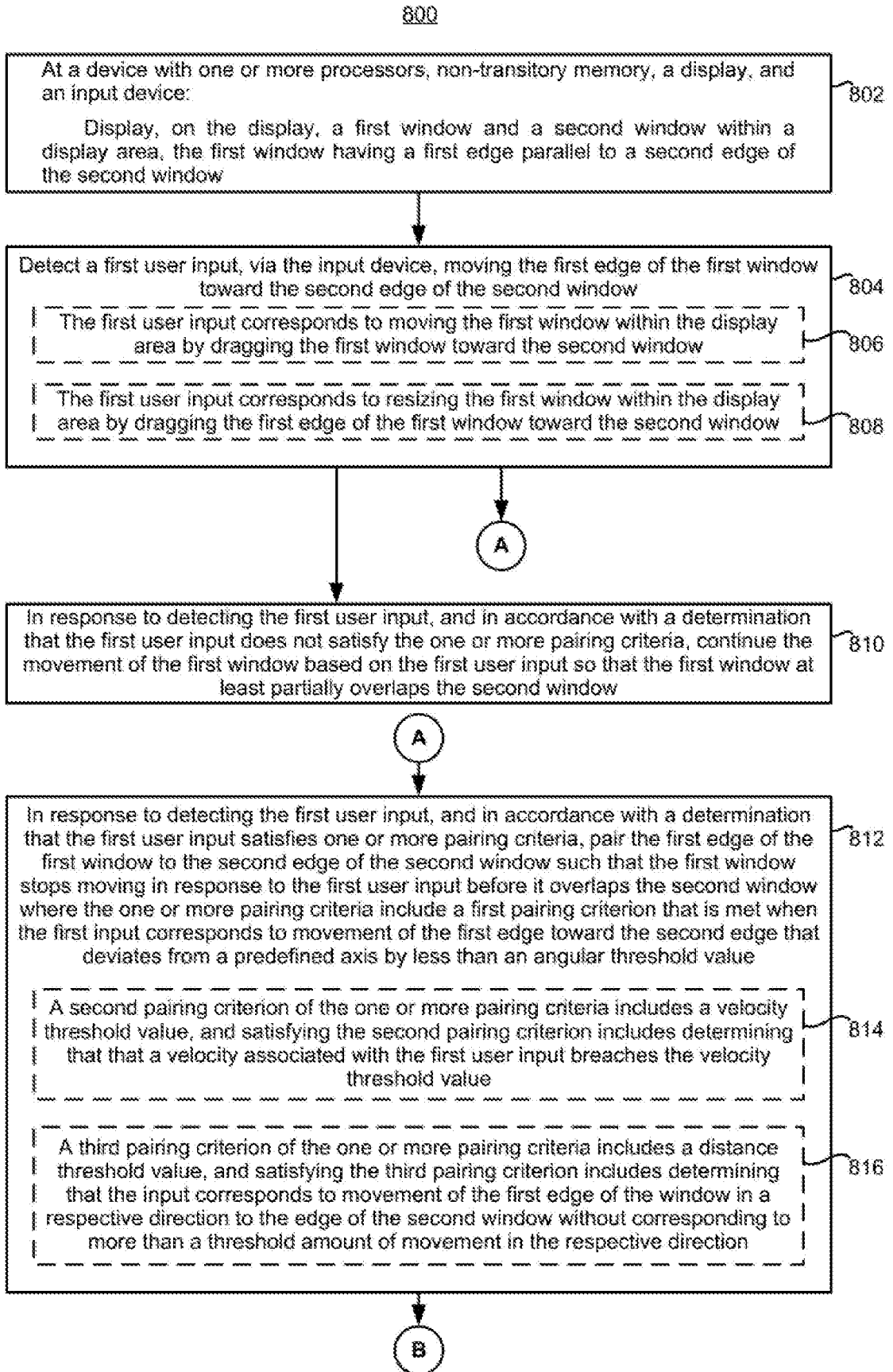

Figure 8A

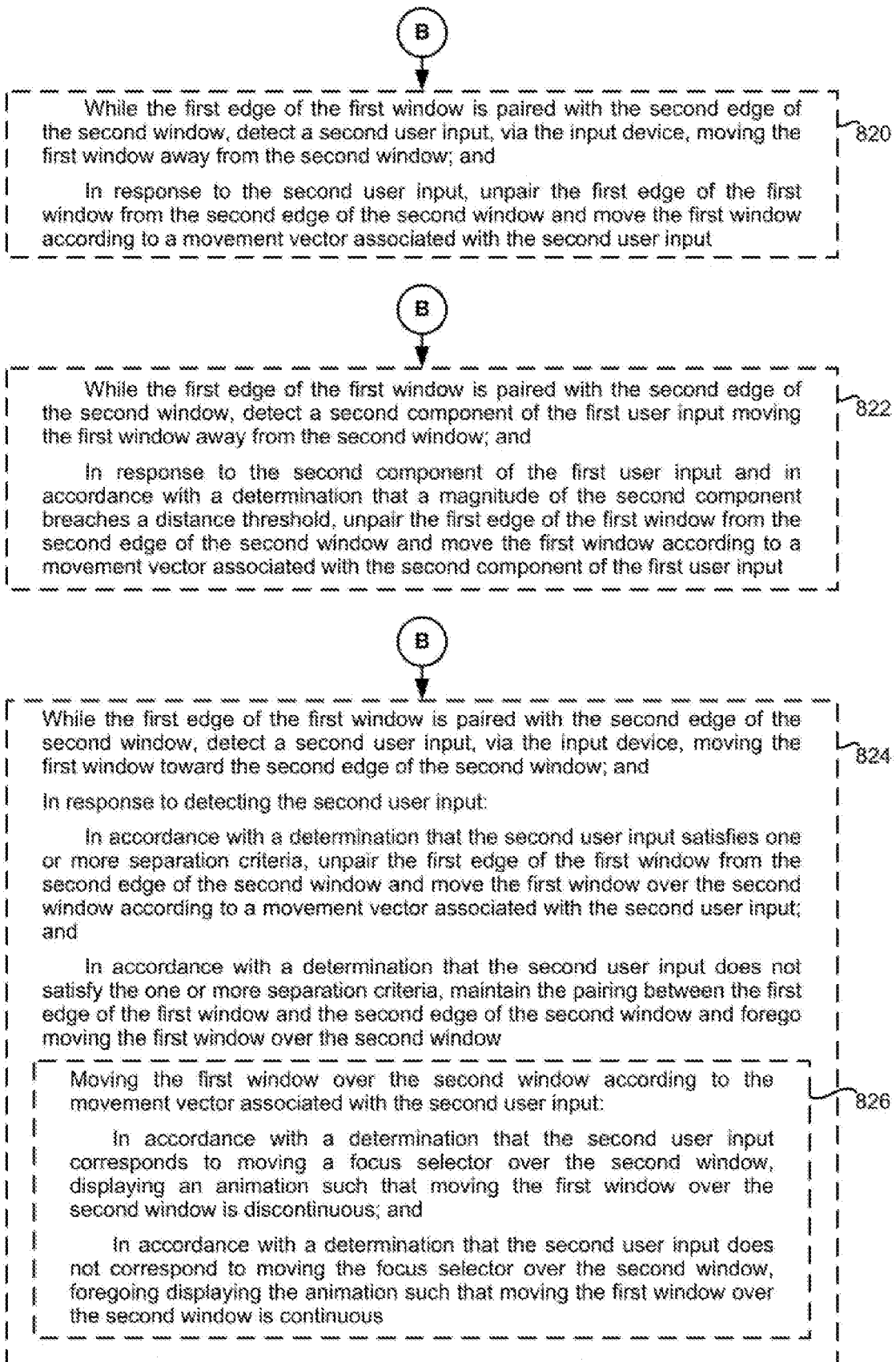
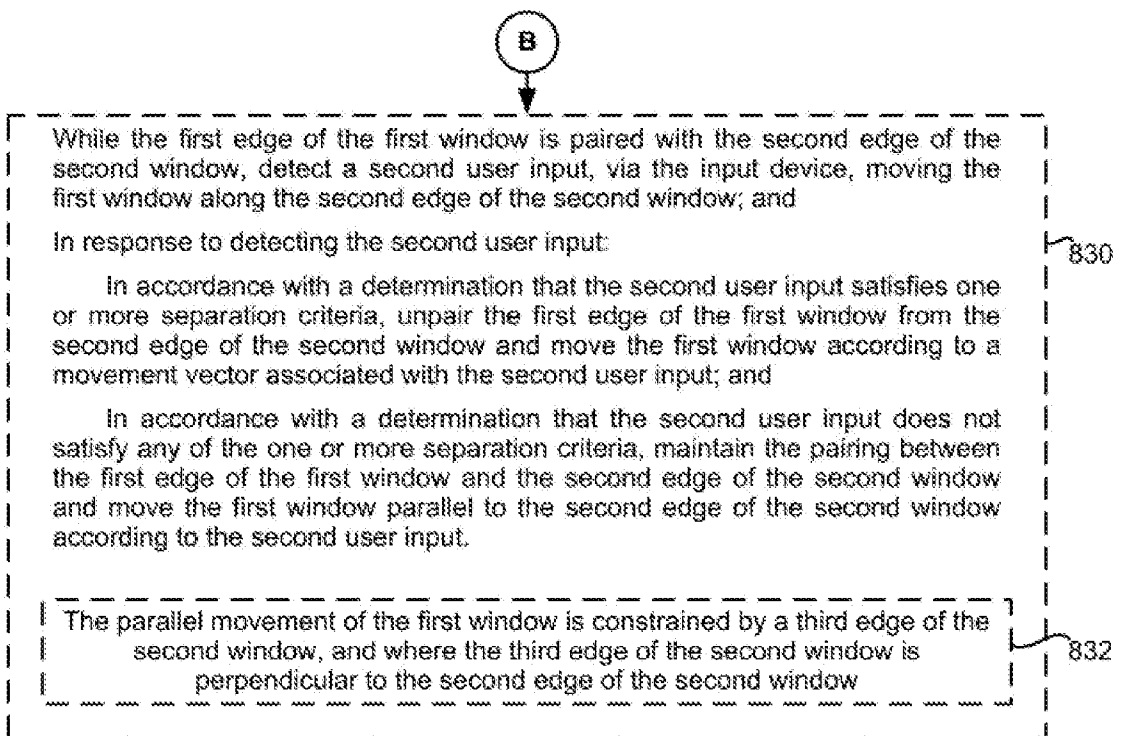
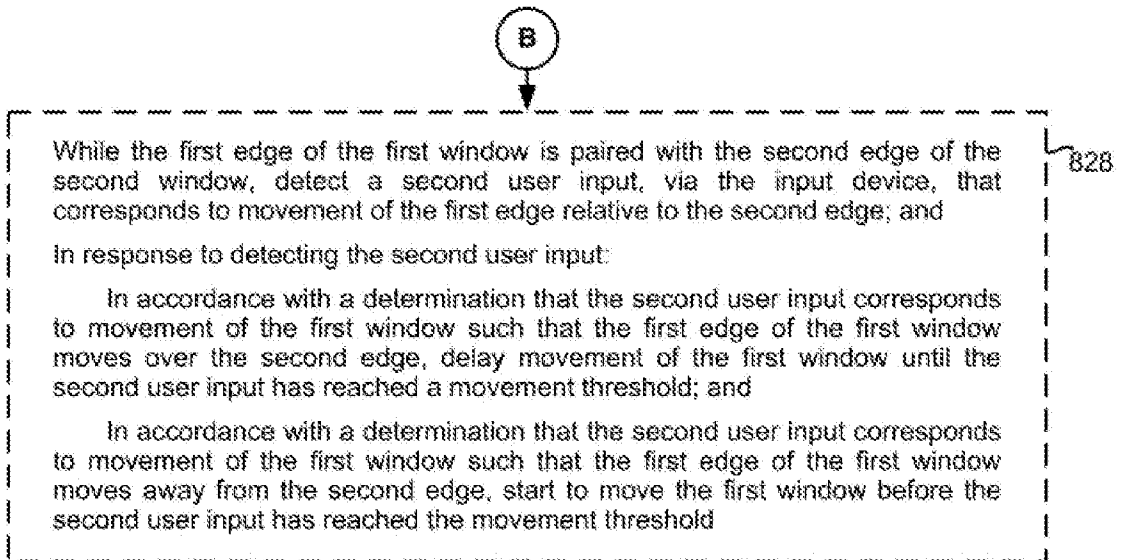
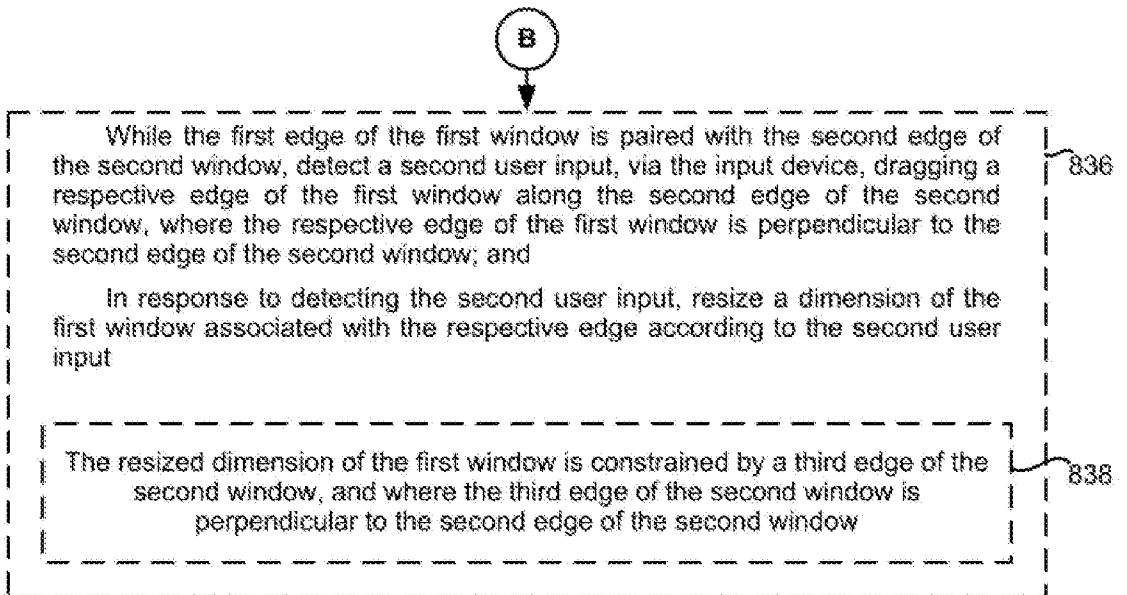
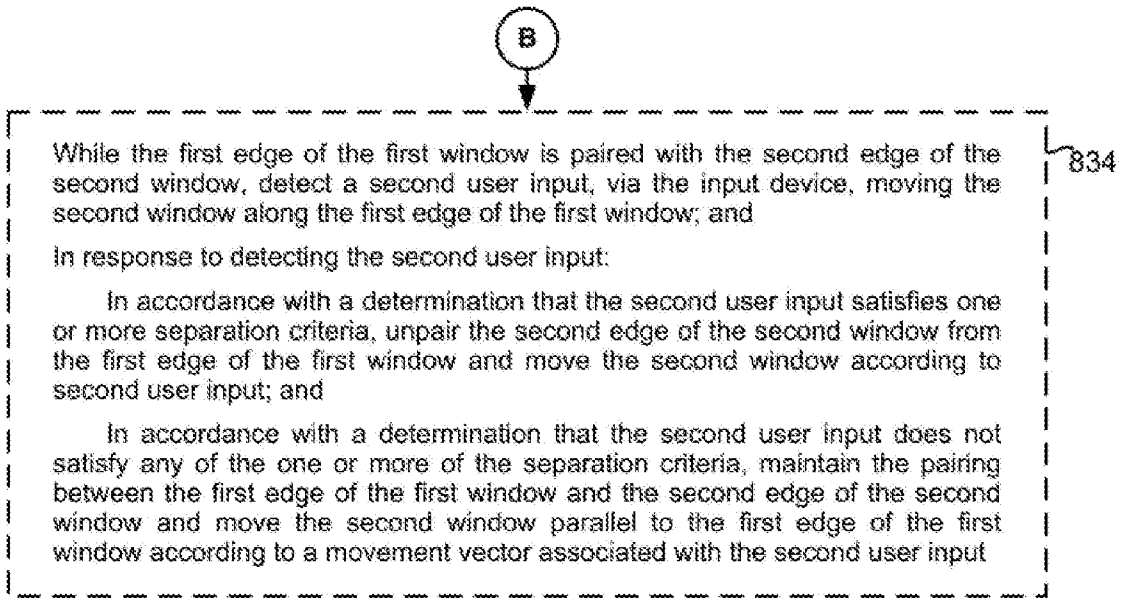

Figure 8B



**Figure 8C**



**Figure 8D**



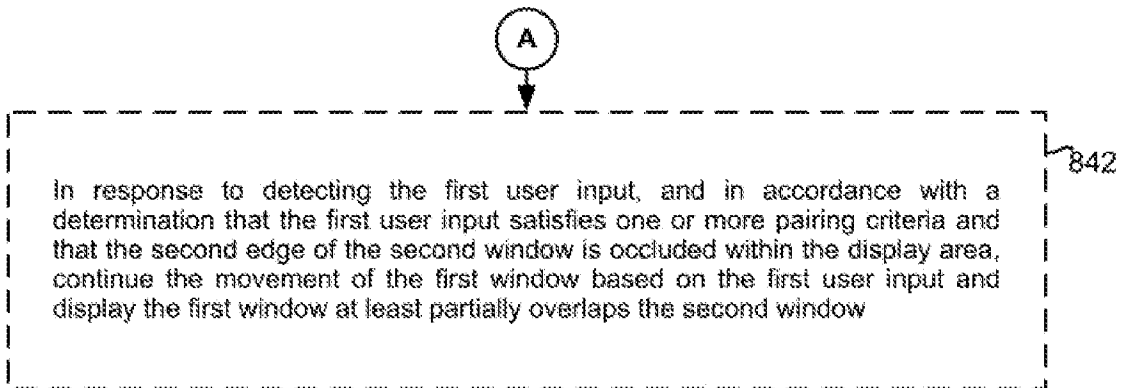
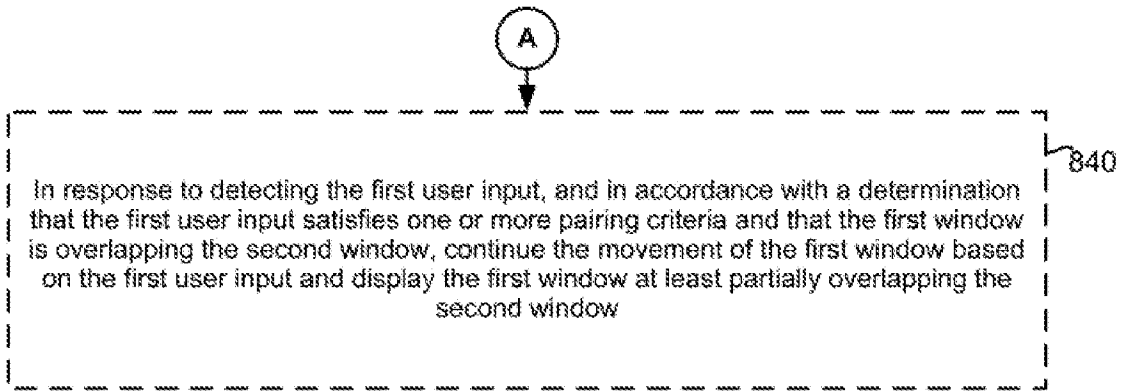
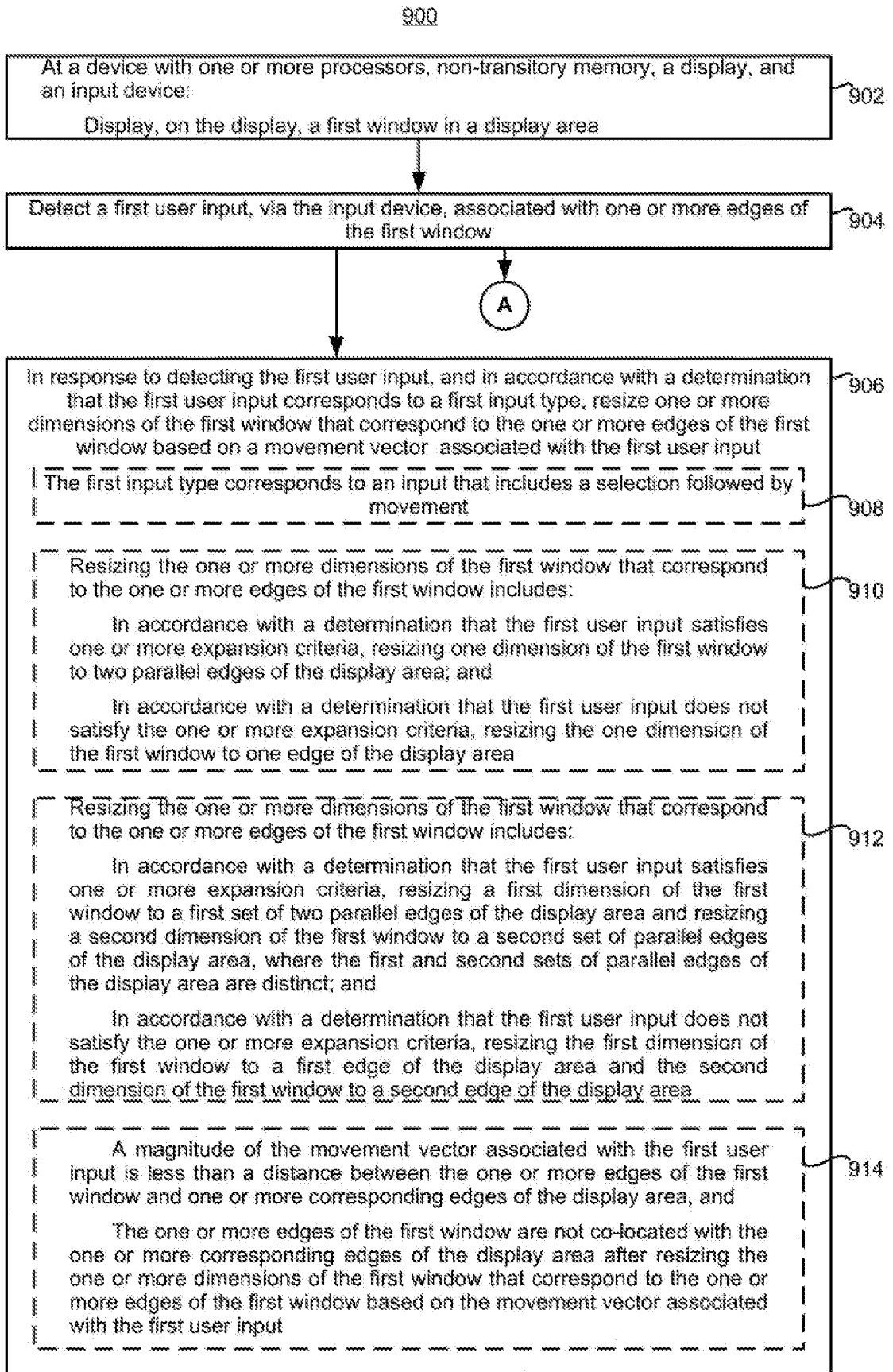

Figure 8E



**Figure 9A**

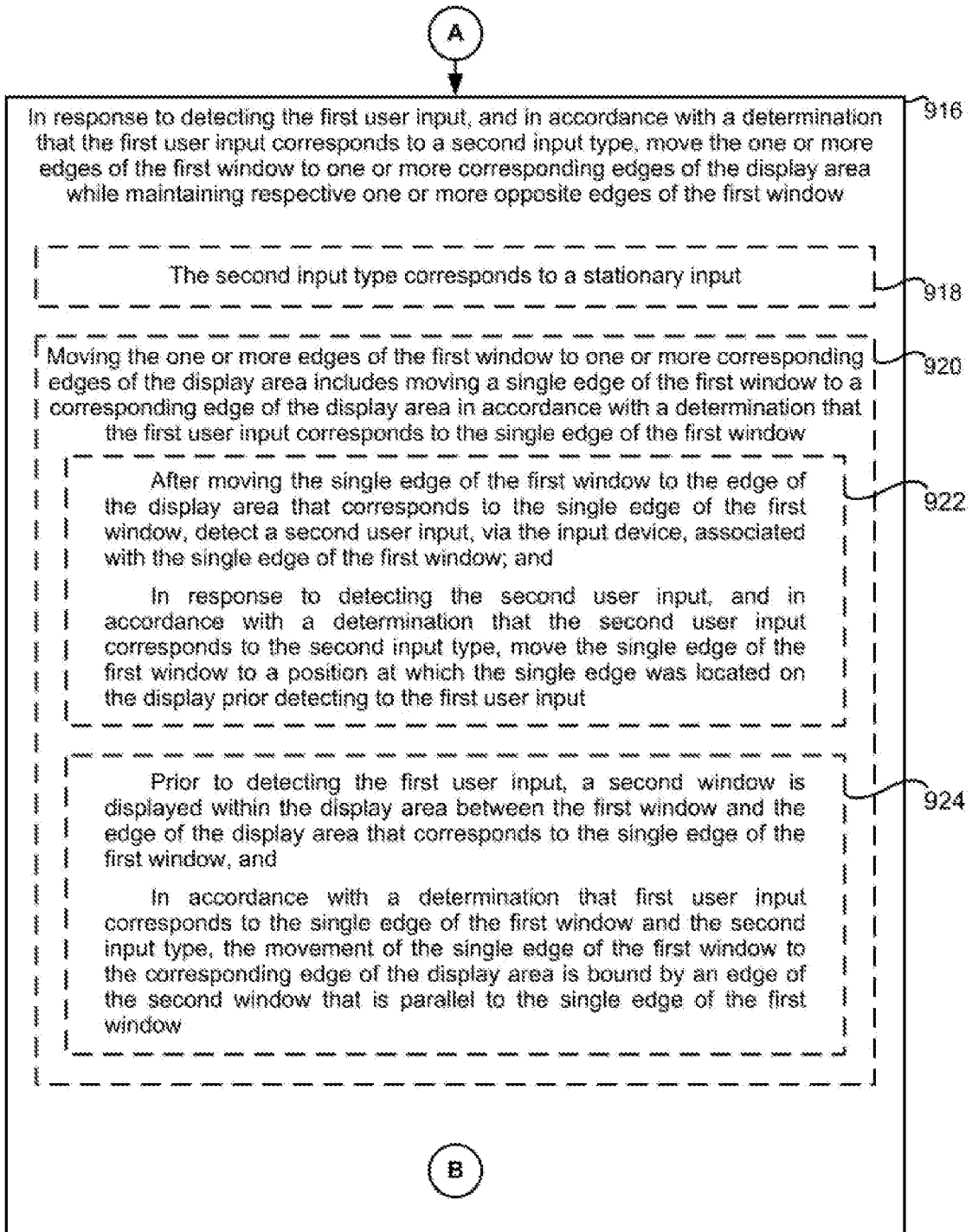

Figure 9B

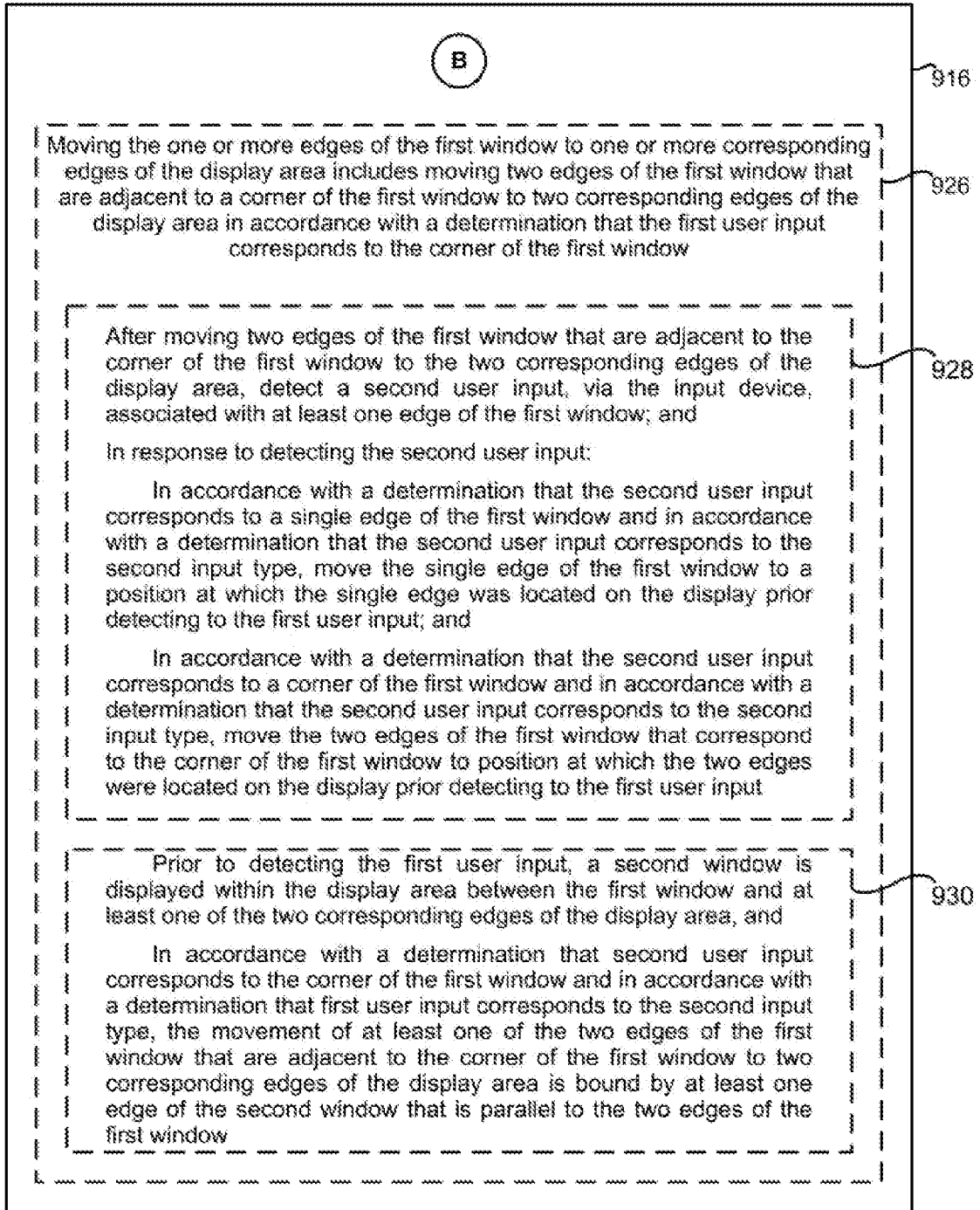
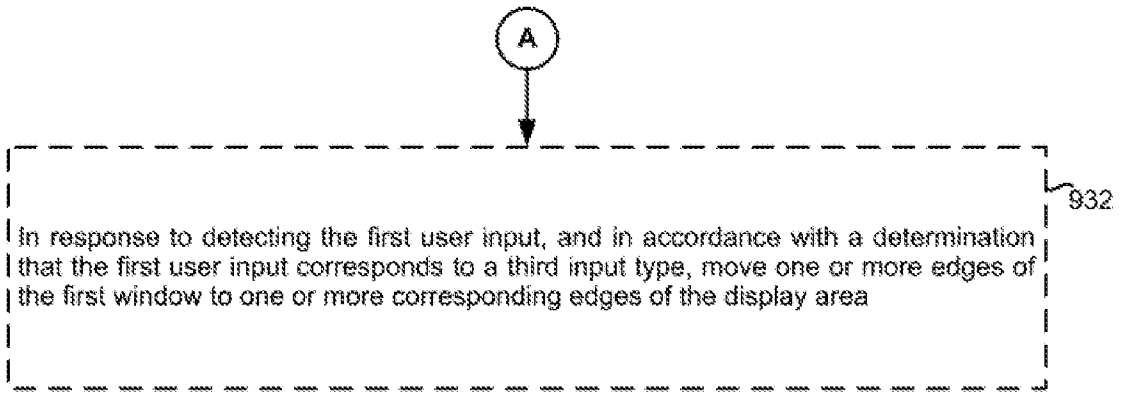

Figure 9C



**Figure 9D**

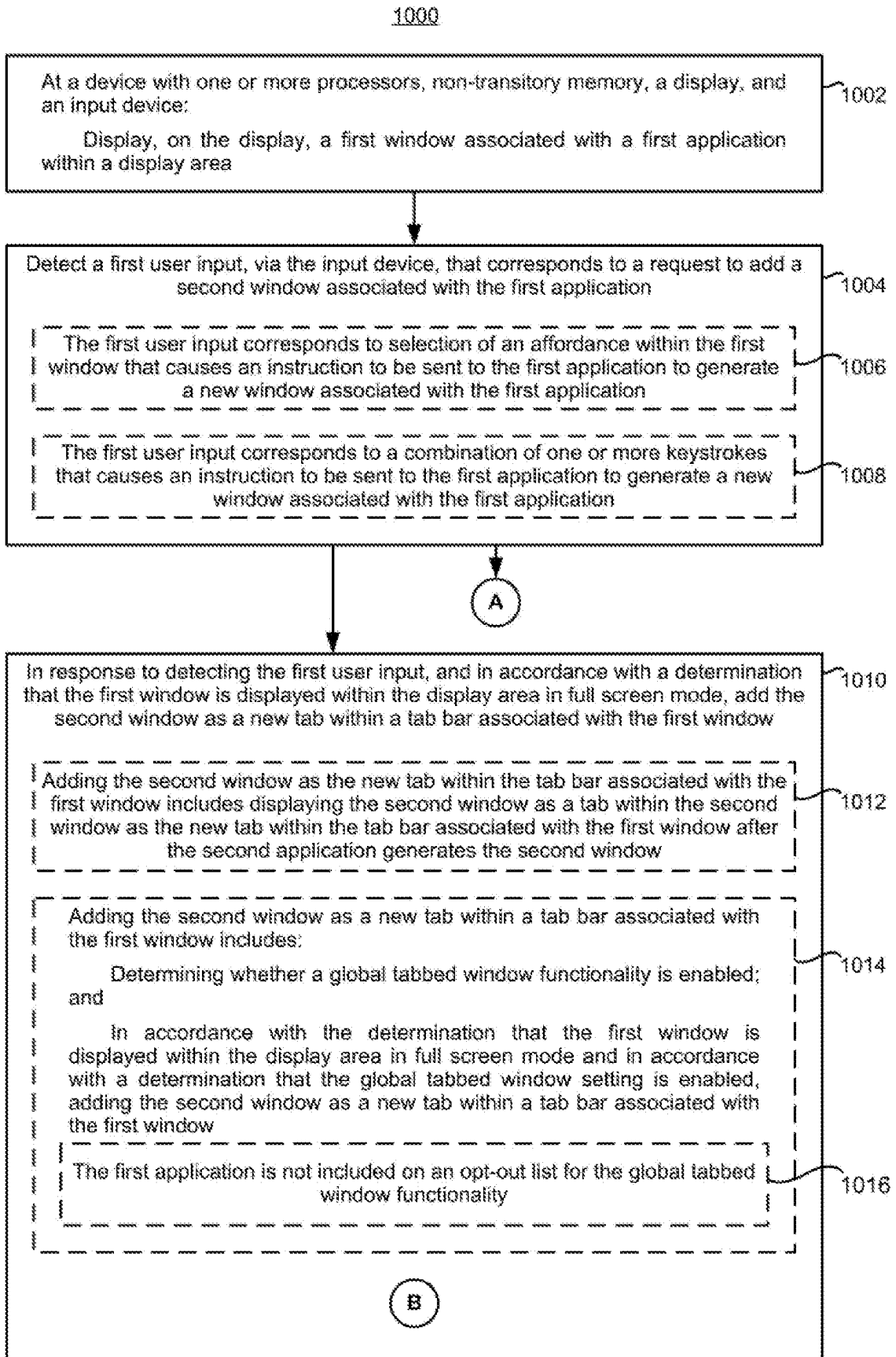
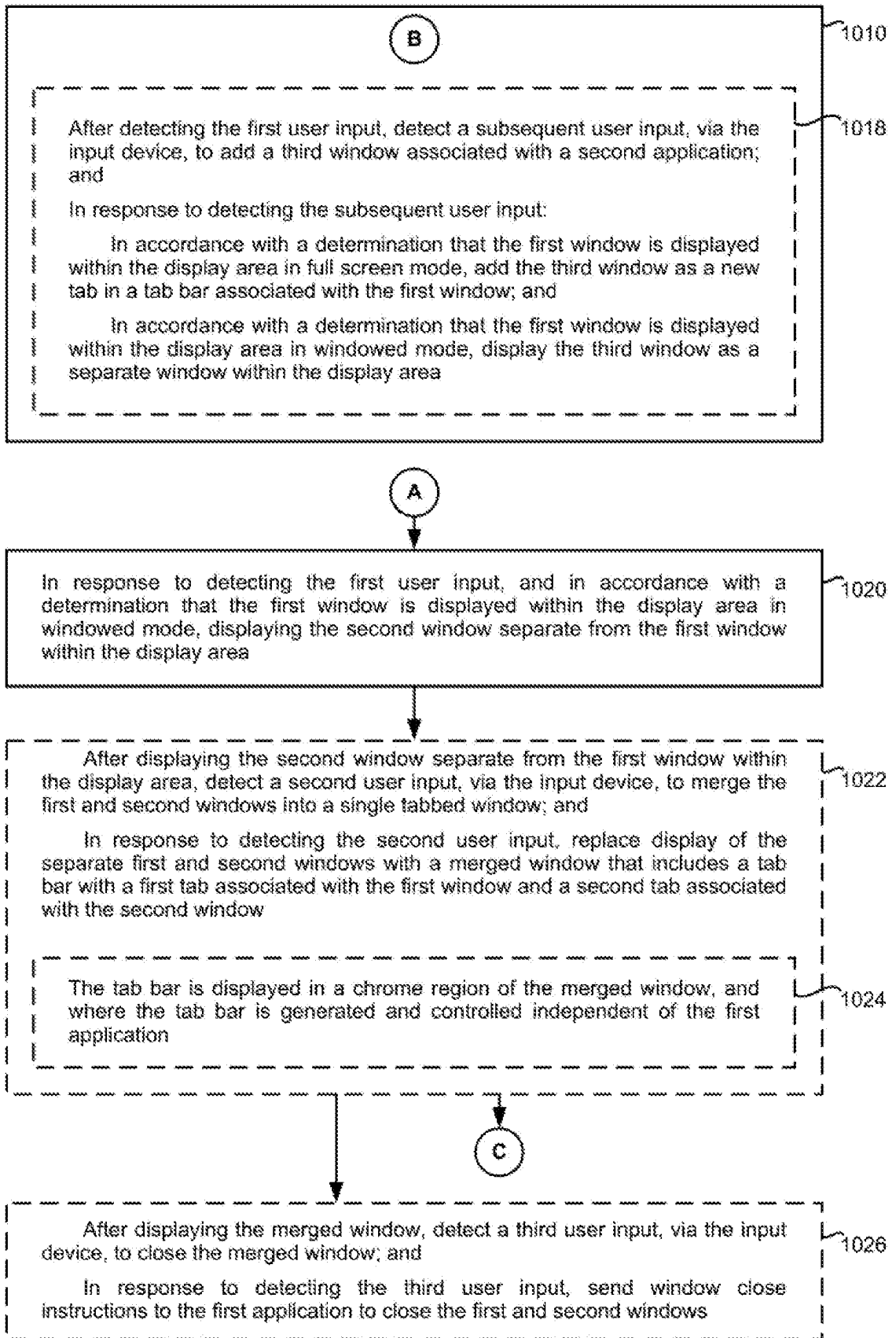

Figure 10A



**Figure 10B**

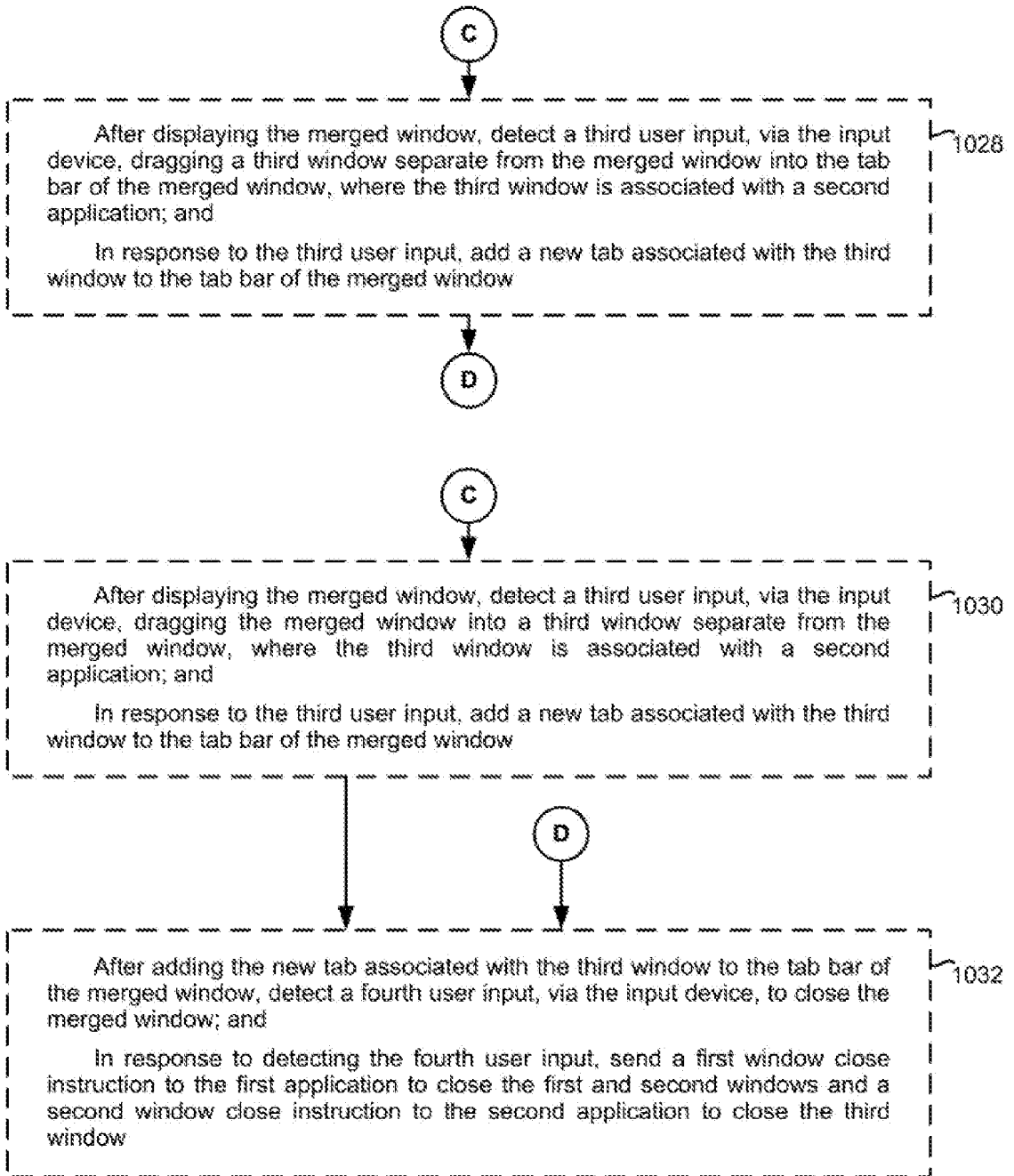

Figure 10C



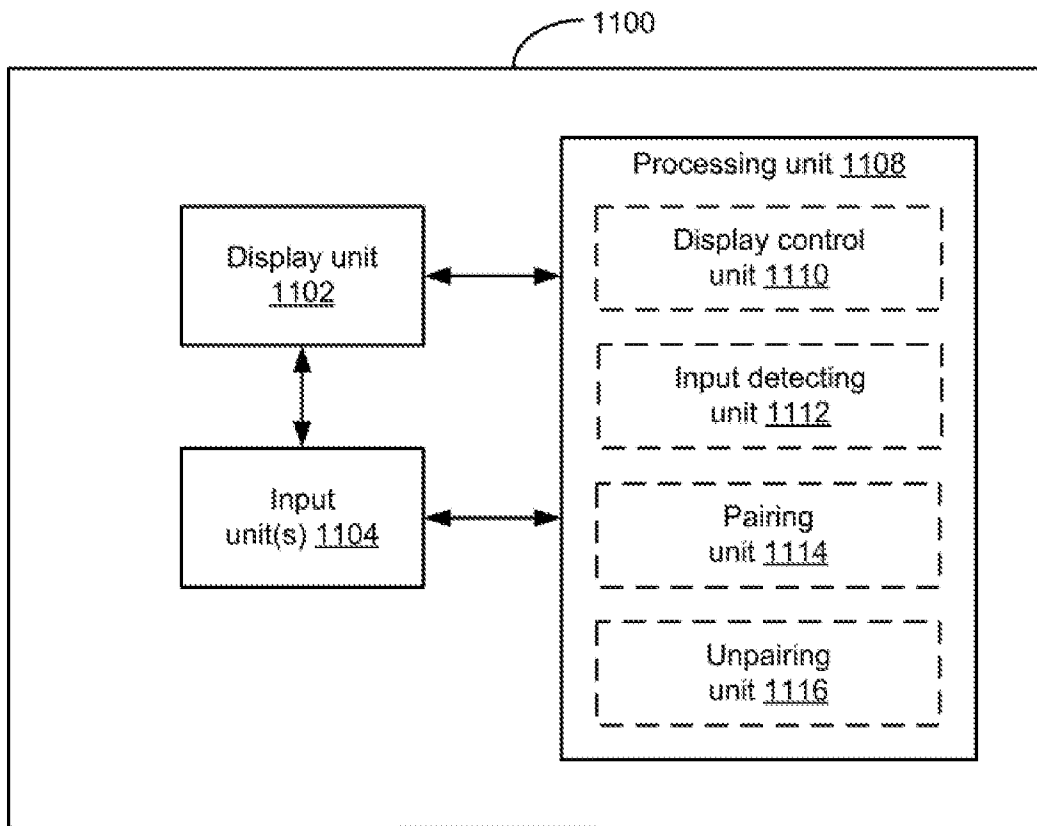

Figure 11

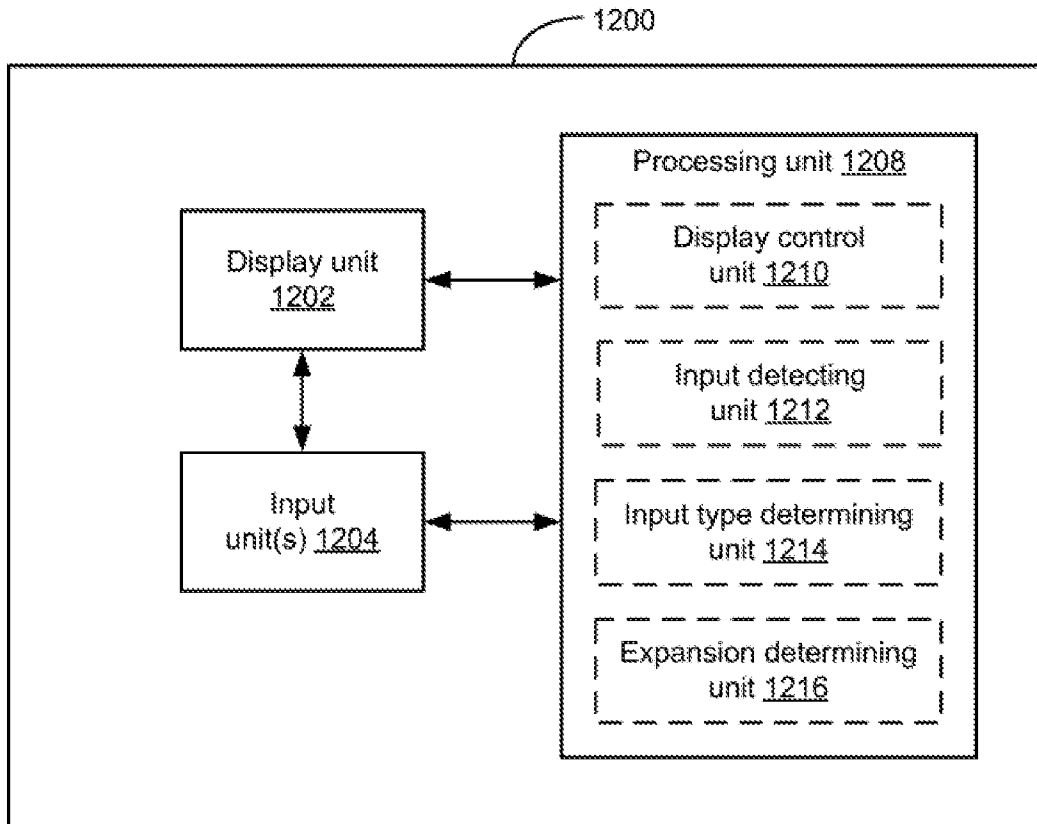

Figure 12

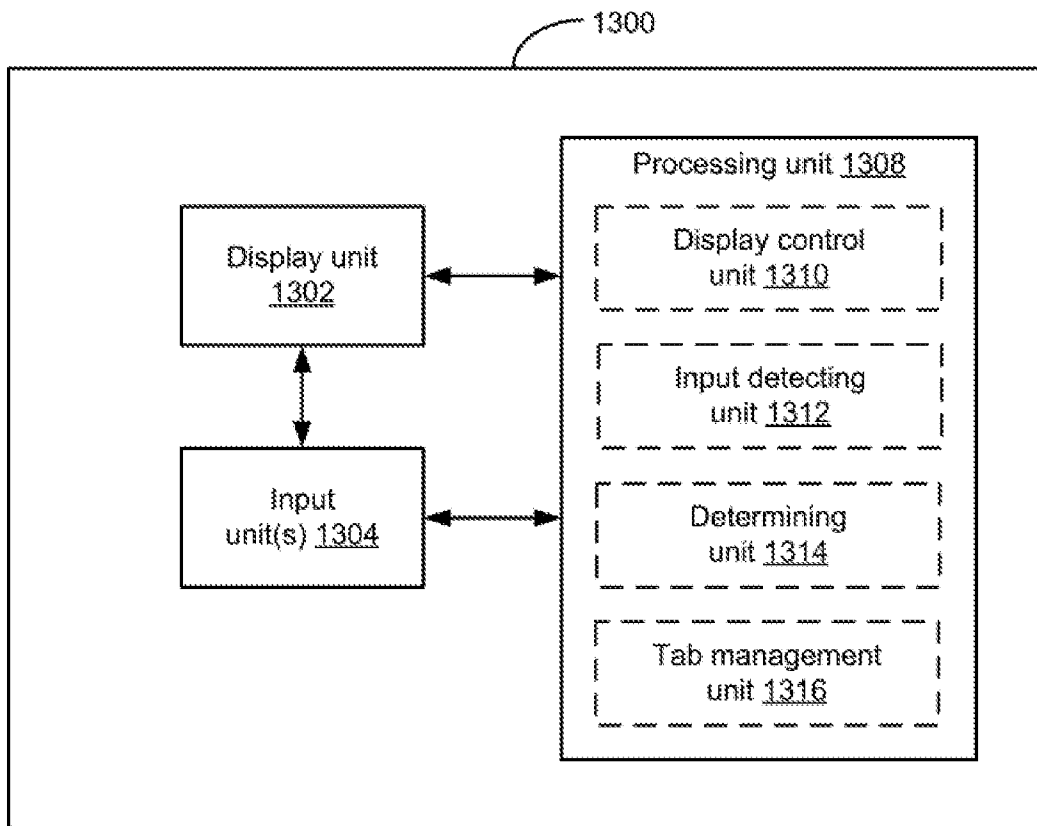

Figure 13

INTERNATIONAL SEARCH REPORT

International application No  
PCT/US2017/035376

A. CLASSIFICATION OF SUBJECT MATTER  
INV. G06F3/0481 G06F9/44  
ADD.  
According to International Patent Classification (IPC) or to both national classification and IPC

B. FIELDS SEARCHED  
Minimum documentation searched (classification system followed by classification symbols)  
G06F G09G  
Documentation searched other than minimum documentation to the extent that such documents are included in the fields searched

Electronic data base consulted during the international search (name of data base and, where practicable, search terms used)  
EPO-Internal, WPI Data

C. DOCUMENTS CONSIDERED TO BE RELEVANT		
Category*	Citation of document, with indication, where appropriate, of the relevant passages	Relevant to claim No.
Y	US 2015/378518 A1 (HEYDLAUF MICHAEL [US]) 31 December 2015 (2015-12-31) paragraph [0013] - paragraph [0024] paragraph [0032] - paragraph [0033] paragraph [0042] - paragraph [0043] figures 1, 2	1-42
Y	US 2016/034156 A1 (VRANJES MIRON [US] ET AL) 4 February 2016 (2016-02-04) paragraph [0132] - paragraph [0134]	1-42
A	US 2012/054674 A1 (BEYKPOUR KAYVON [US] ET AL) 1 March 2012 (2012-03-01) paragraph [0042] - paragraph [0051]	4,5,29, 30
	----- -/--	

Further documents are listed in the continuation of Box C.

See patent family annex.

\* Special categories of cited documents :

<p>"A" document defining the general state of the art which is not considered to be of particular relevance</p> <p>"E" earlier application or patent but published on or after the international filing date</p> <p>"L" document which may throw doubts on priority claim(s) or which is cited to establish the publication date of another citation or other special reason (as specified)</p> <p>"O" document referring to an oral disclosure, use, exhibition or other means</p> <p>"P" document published prior to the international filing date but later than the priority date claimed</p>	<p>"T" later document published after the international filing date or priority date and not in conflict with the application but cited to understand the principle or theory underlying the invention</p> <p>"X" document of particular relevance; the claimed invention cannot be considered novel or cannot be considered to involve an inventive step when the document is taken alone</p> <p>"Y" document of particular relevance; the claimed invention cannot be considered to involve an inventive step when the document is combined with one or more other such documents, such combination being obvious to a person skilled in the art</p> <p>"&amp;" document member of the same patent family</p>
---	---

Date of the actual completion of the international search  14 August 2017	Date of mailing of the international search report  08/11/2017
---	--

Name and mailing address of the ISA/ European Patent Office, P.B. 5818 Patentlaan 2 NL - 2280 HV Rijswijk Tel. (+31-70) 340-2040, Fax: (+31-70) 340-3016	Authorized officer  Schmidt, Daniel
--	---

## INTERNATIONAL SEARCH REPORT

International application No  
PCT/US2017/035376

C(Continuation). DOCUMENTS CONSIDERED TO BE RELEVANT		
Category*	Citation of document, with indication, where appropriate, of the relevant passages	Relevant to claim No.
A	US 2005/125742 A1 (GROTJOHN D KIRK [US] ET AL) 9 June 2005 (2005-06-09) paragraph [0022] - paragraph [0027] figures 1-5	1-42
A	----- US 5 771 042 A (SANTOS-GOMEZ LUCINIO [US]) 23 June 1998 (1998-06-23) column 4, line 17 - column 6, line 7 column 7, line 29 - line 32 figures 2, 3 -----	1-42

# INTERNATIONAL SEARCH REPORT

International application No.  
PCT/US2017/035376

## Box No. II Observations where certain claims were found unsearchable (Continuation of item 2 of first sheet)

This international search report has not been established in respect of certain claims under Article 17(2)(a) for the following reasons:

1.  Claims Nos.:  
because they relate to subject matter not required to be searched by this Authority, namely:
  
2.  Claims Nos.:  
because they relate to parts of the international application that do not comply with the prescribed requirements to such an extent that no meaningful international search can be carried out, specifically:
  
3.  Claims Nos.:  
because they are dependent claims and are not drafted in accordance with the second and third sentences of Rule 6.4(a).

## Box No. III Observations where unity of invention is lacking (Continuation of item 3 of first sheet)

This International Searching Authority found multiple inventions in this international application, as follows:

see additional sheet

1.  As all required additional search fees were timely paid by the applicant, this international search report covers all searchable claims.
  
2.  As all searchable claims could be searched without effort justifying an additional fees, this Authority did not invite payment of additional fees.
  
3.  As only some of the required additional search fees were timely paid by the applicant, this international search report covers only those claims for which fees were paid, specifically claims Nos.:
  
4.  No required additional search fees were timely paid by the applicant. Consequently, this international search report is restricted to the invention first mentioned in the claims; it is covered by claims Nos.:

1-42

### Remark on Protest

- The additional search fees were accompanied by the applicant's protest and, where applicable, the payment of a protest fee.
- The additional search fees were accompanied by the applicant's protest but the applicable protest fee was not paid within the time limit specified in the invitation.
- No protest accompanied the payment of additional search fees.

**FURTHER INFORMATION CONTINUED FROM PCT/ISA/ 210**

This International Searching Authority found multiple (groups of) inventions in this international application, as follows:

1. claims: 1-42

Pairing a first and a second window based on one or more pairing criteria, wherein the one or more pairing criteria include a first pairing criterion that is met when a first user input corresponds to movement of the first window toward the second window that deviates from a predefined axis by less than an angular threshold value.

---

2. claims: 43-76

Resizing a window based on a type of user input, wherein in accordance with a determination that the user input corresponds to a first input type, resizing one or more dimensions of the window that correspond to the one or more edges of the window based on a movement vector associated with the user input; and in accordance with a determination that the user input corresponds to a second input type, moving the one or more edges of the window to one or more corresponding edges of a display area while maintaining respective one or more opposite edges of the window.

---

3. claims: 77-110

Adding a new window to a graphical user interface based on a displaying mode of a first window, wherein in accordance with a determination that the first window is displayed within a display area in full screen mode, adding the new window as a new tab within a tab bar associated with the first window; and in accordance with a determination that the first window is displayed within the display area in windowed mode, displaying the new window separate from the first window within the display area.

---

# INTERNATIONAL SEARCH REPORT

Information on patent family members

International application No

PCT/US2017/035376

Patent document cited in search report	Publication date	Patent family member(s)	Publication date	
US 2015378518	A1	31-12-2015	EP 2972720 A2	20-01-2016
			US 2015378518 A1	31-12-2015
			WO 2014149649 A2	25-09-2014
-----				
US 2016034156	A1	04-02-2016	AU 2015296846 A1	12-01-2017
			CA 2955619 A1	04-02-2016
			CN 106662964 A	10-05-2017
			EP 3175341 A1	07-06-2017
			JP 2017526054 A	07-09-2017
			KR 20170040283 A	12-04-2017
			US 2016034156 A1	04-02-2016
			WO 2016018801 A1	04-02-2016
-----				
US 2012054674	A1	01-03-2012	NONE	
-----				
US 2005125742	A1	09-06-2005	NONE	
-----				
US 5771042	A	23-06-1998	NONE	
-----				