



US 20120250147A1

(19) **United States**

(12) **Patent Application Publication**

Shafer et al.

(10) **Pub. No.: US 2012/0250147 A1**

(43) **Pub. Date: Oct. 4, 2012**

(54) **CATADIOPTRIC PROJECTION OBJECTIVE**

(75) Inventors: **David Shafer**, Fairfield, CT (US); **Wilhelm Ulrich**, Aalen (DE); **Aurelian Dodoc**, Heidenheim (DE); **Rudolf Von Buenau**, Jena (DE); **Hans-Juergen Mann**, Oberkochen (DE); **Alexander Epple**, Aalen (DE); **Susanne Beder**, Aalen (DE); **Wolfgang Singer**, Rochester, MN (US)

60/612,823, filed on Sep. 24, 2004, provisional application No. 60/617,674, filed on Oct. 13, 2004, provisional application No. 60/654,950, filed on Feb. 23, 2005, provisional application No. 60/587,504, filed on Jul. 14, 2004, provisional application No. 60/591,775, filed on Jul. 27, 2004, provisional application No. 60/612,823, filed on Sep. 24, 2004, provisional application No. 60/617,674, filed on Oct. 13, 2004, provisional application No. 60/536,248, filed on Jan. 14, 2004.

(73) Assignee: **Carl Zeiss SMT AG**, Oberkochen (DE)

(21) Appl. No.: **13/470,956**

(22) Filed: **May 14, 2012**

Publication Classification
(51) **Int. Cl.**
G02B 17/08 (2006.01)
(52) **U.S. Cl.** **359/365**
(57) **ABSTRACT**

Related U.S. Application Data

(63) Continuation of application No. 11/653,366, filed on Jan. 16, 2007, now Pat. No. 8,208,198, which is a continuation-in-part of application No. PCT/EP2005/007431, filed on Jul. 8, 2005, said application No. 11/653,366 is a continuation-in-part of application No. 11/035,103, filed on Jan. 14, 2005, now Pat. No. 7,385,756.
(60) Provisional application No. 60/587,504, filed on Jul. 14, 2004, provisional application No. 60/591,775, filed on Jul. 27, 2004, provisional application No.

A catadioptric projection objective for imaging a pattern provided in an object plane of the projection objective onto an image plane of the projection objective has a first, refractive objective part for imaging the pattern provided in the object plane into a first intermediate image; a second objective part including at least one concave mirror for imaging the first intermediate image into a second intermediate image; and a third, refractive objective part for imaging the second intermediate image onto the image plane; wherein the projection objective has a maximum lens diameter D_{max} , a maximum image field height Y' , and an image side numerical aperture NA; wherein $COMP1 = D_{max} / (Y' \cdot NA^2)$ and wherein the condition $COMP1 < 10$ holds.

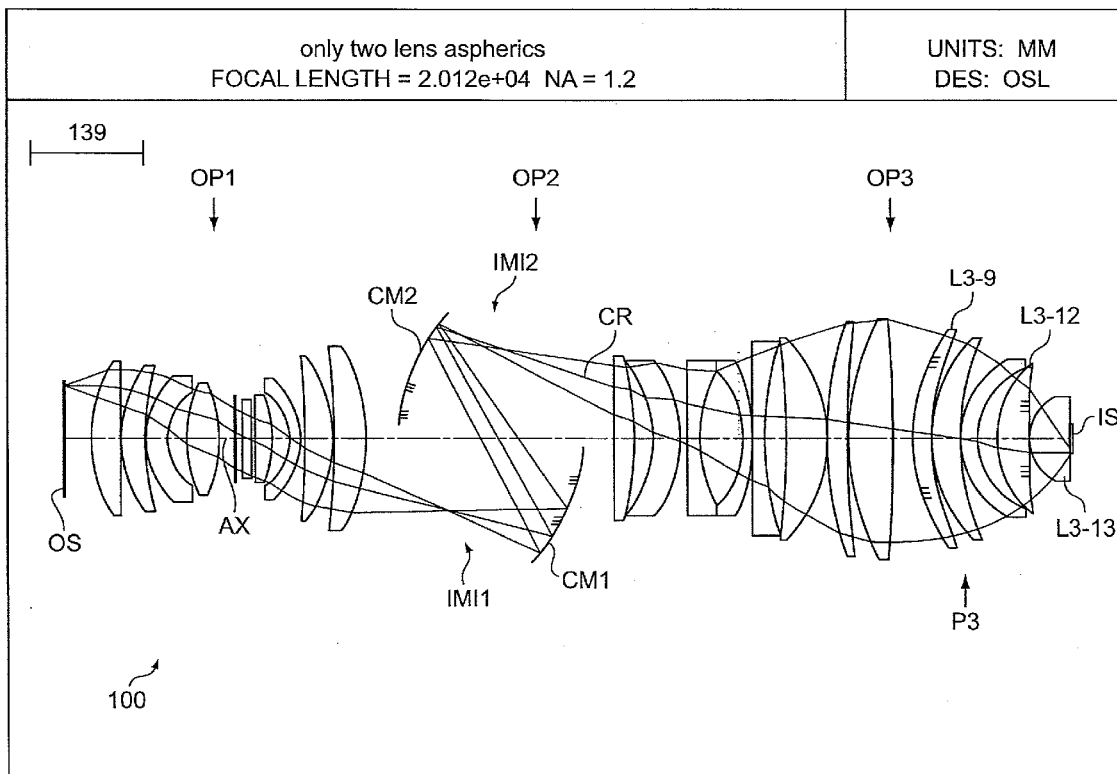

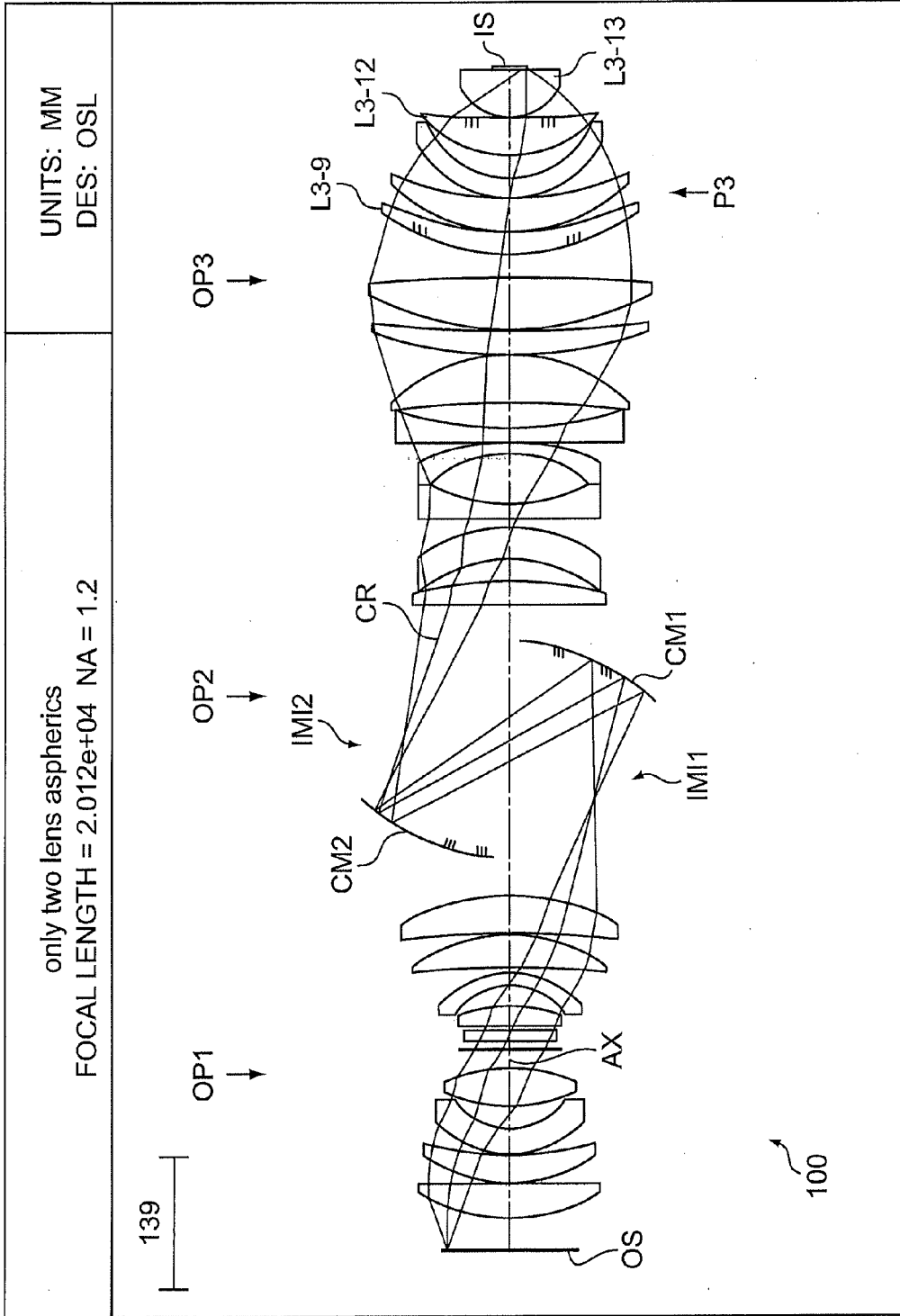

FIG. 1

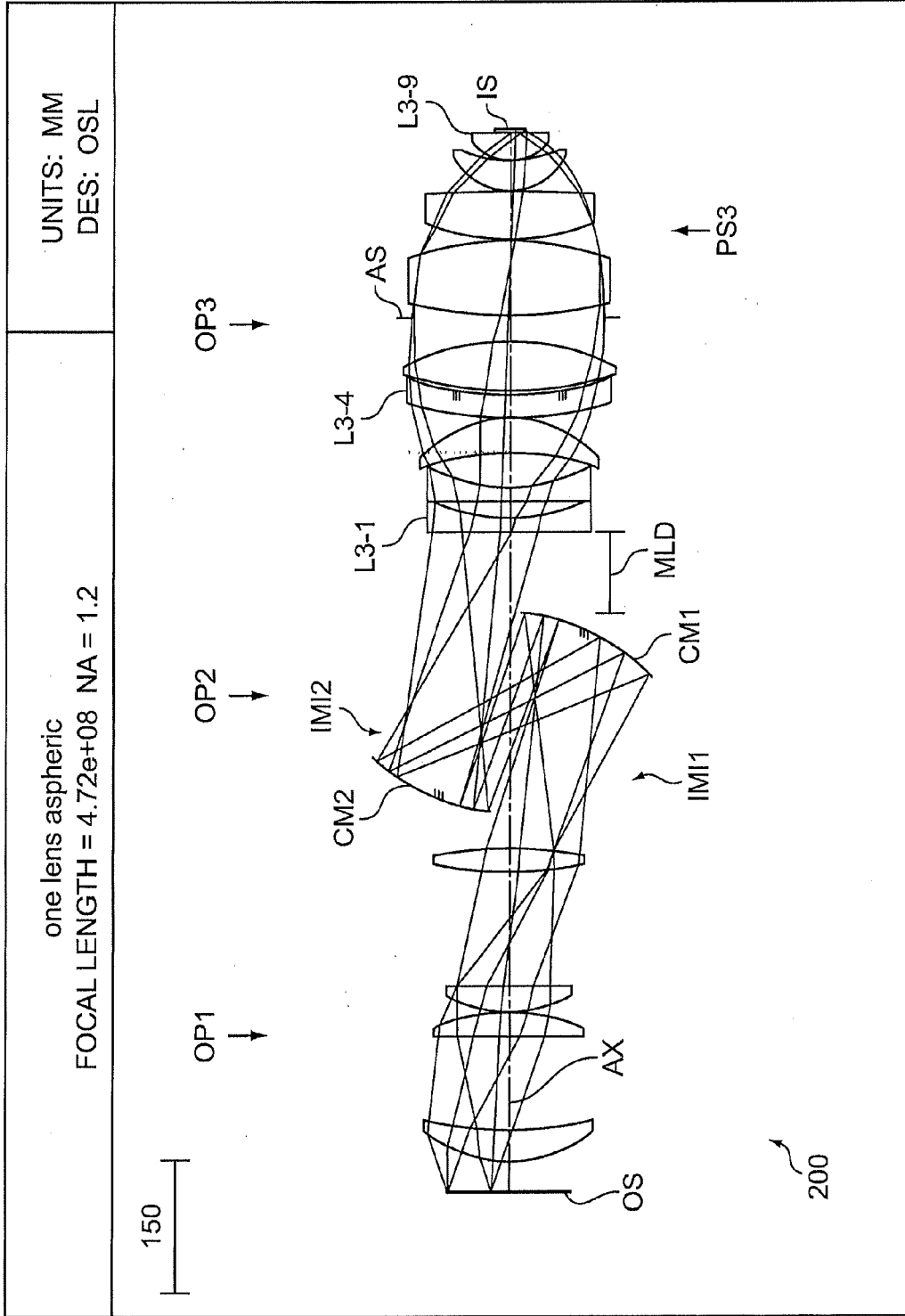

FIG. 2

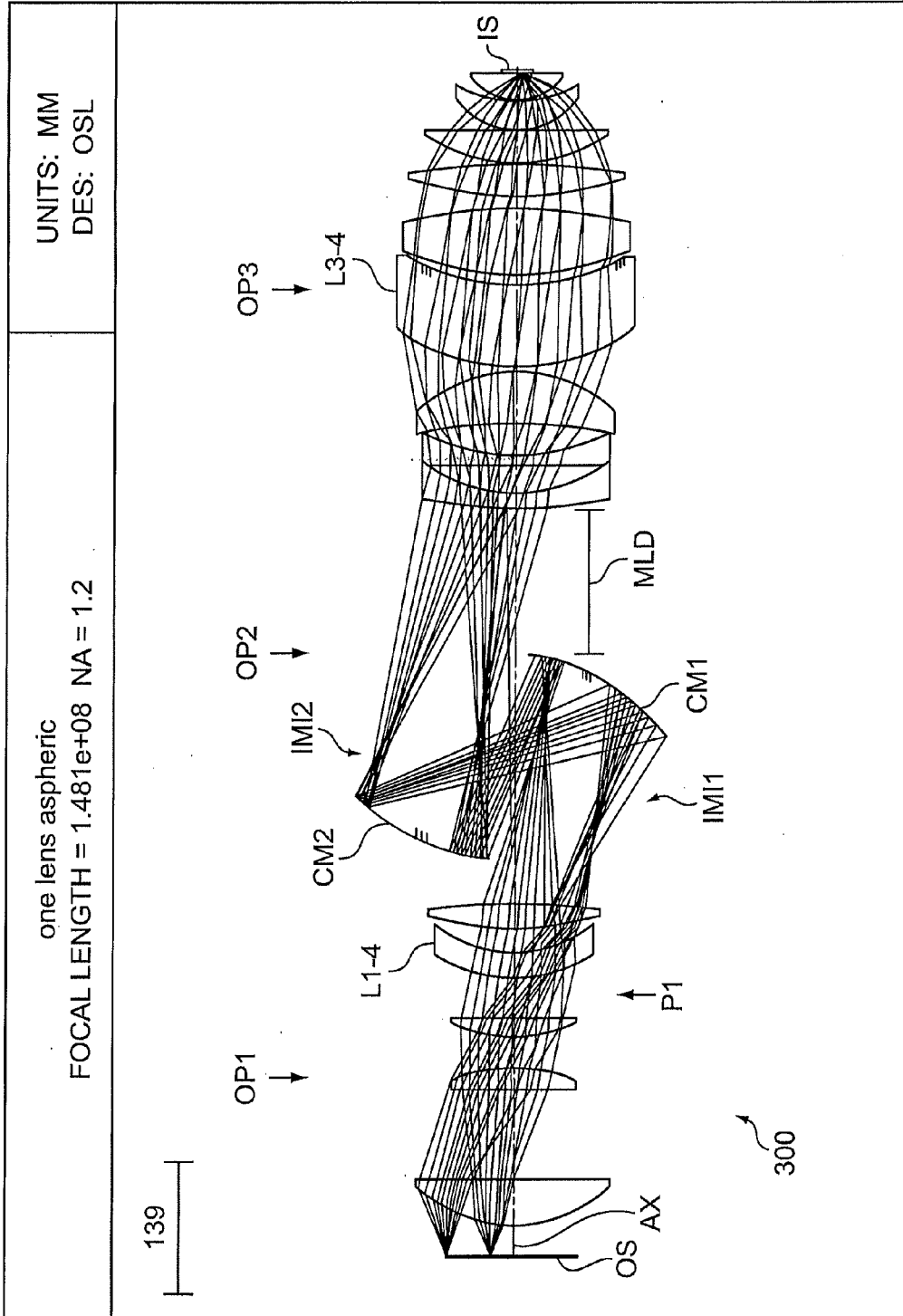

FIG. 3

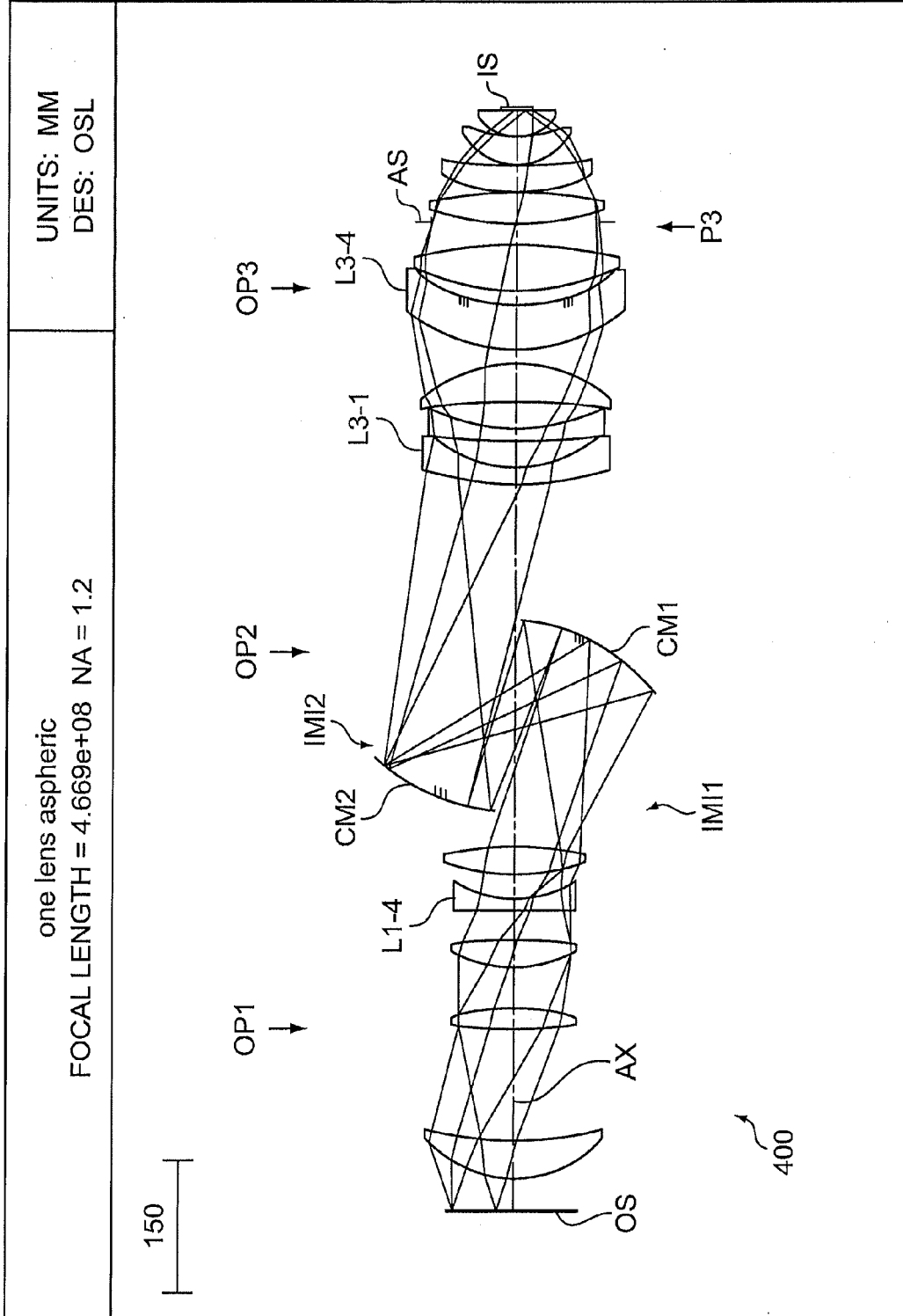

FIG. 4

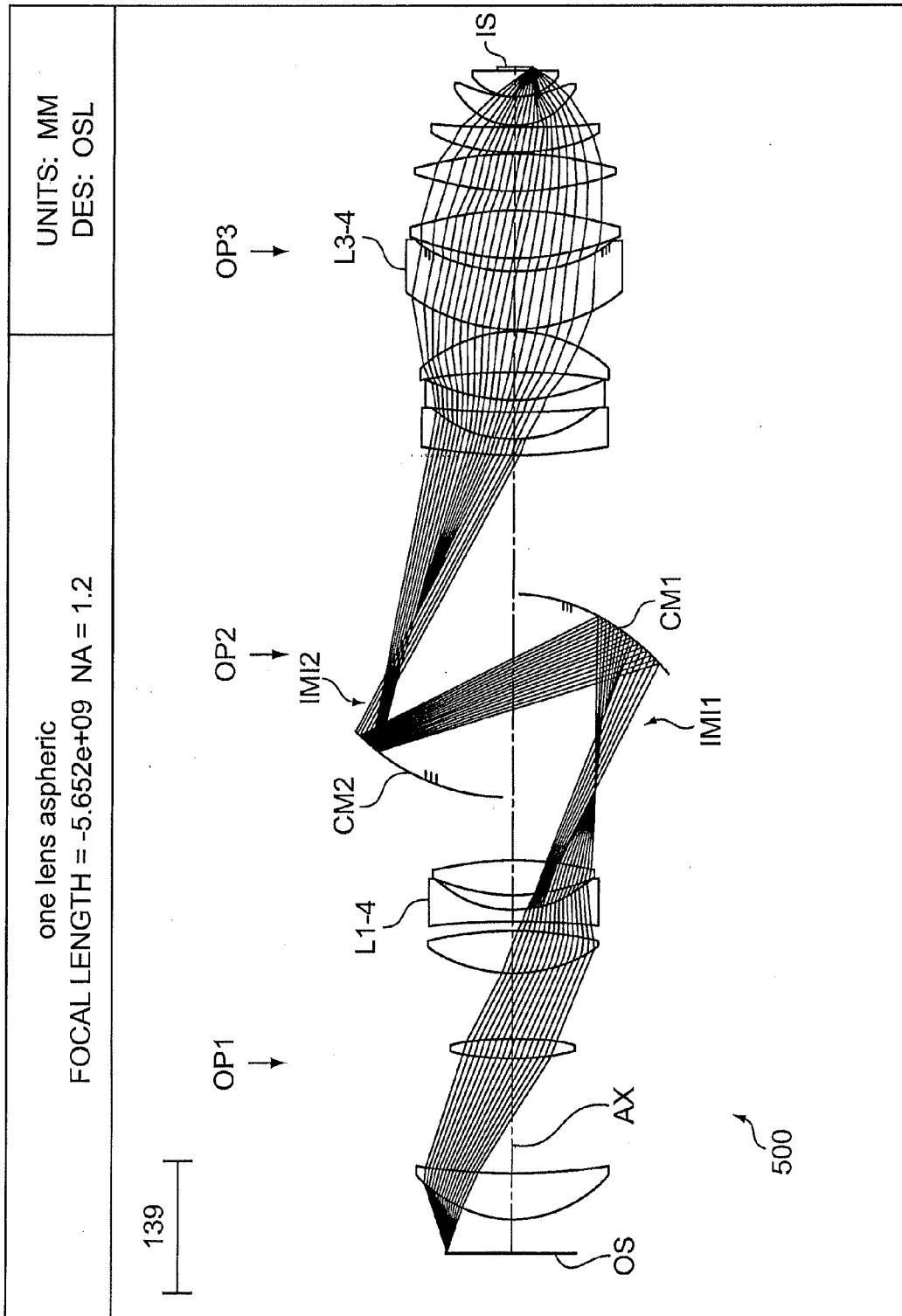

FIG. 5

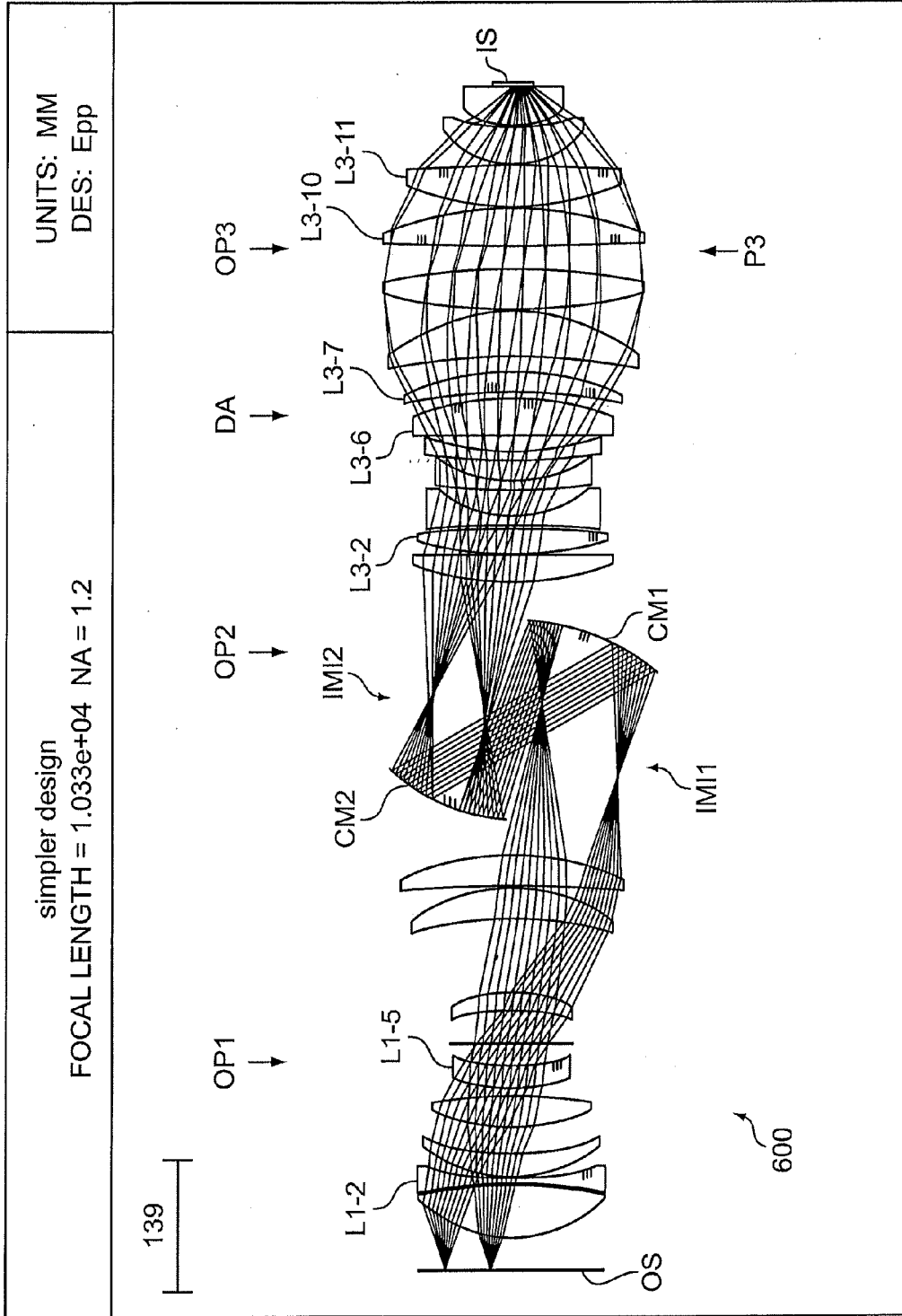
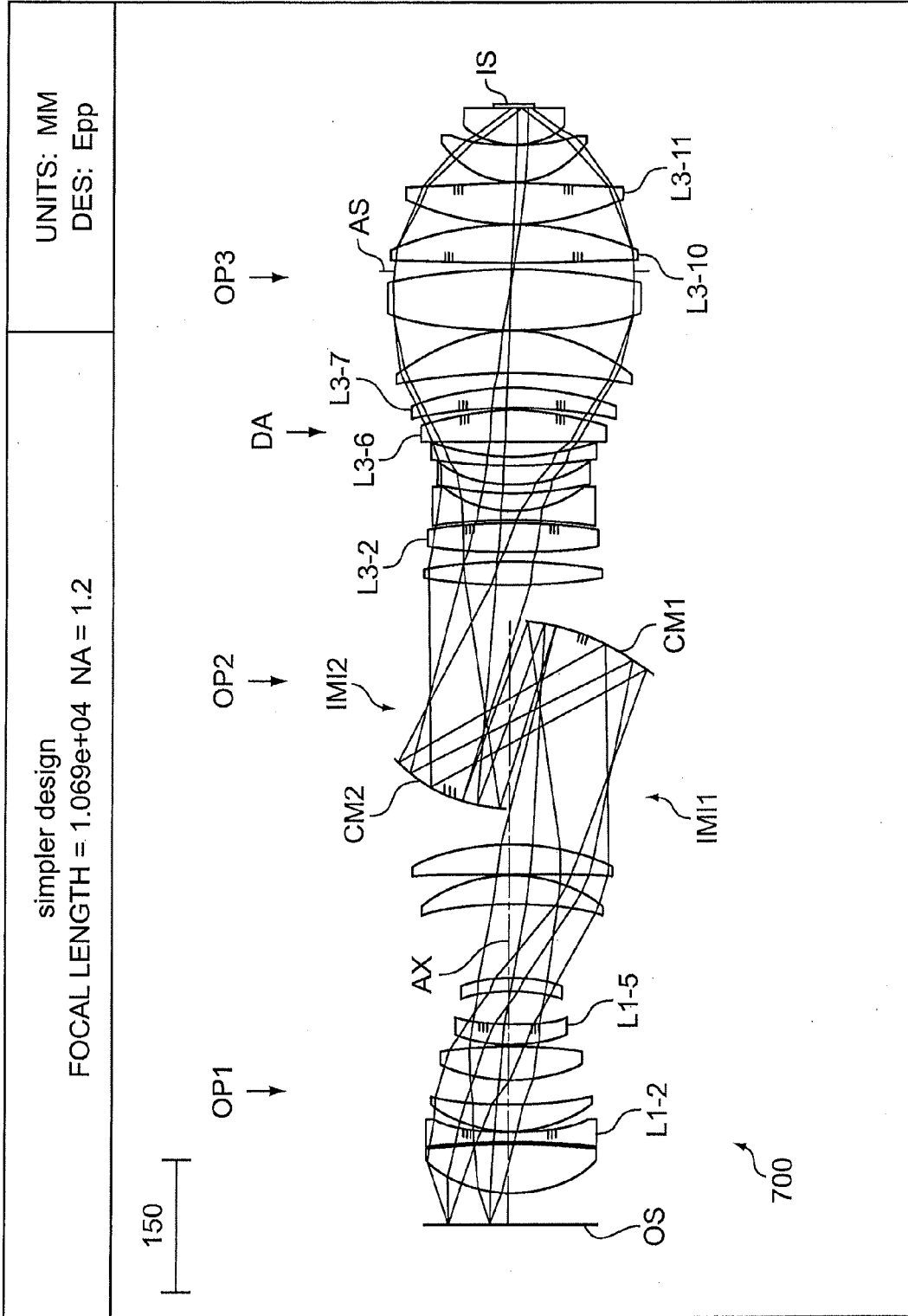

FIG. 6



UNITS: MM
DES: Epp

simpler design
FOCAL LENGTH = 1.069e+04 NA = 1.2

FIG. 7

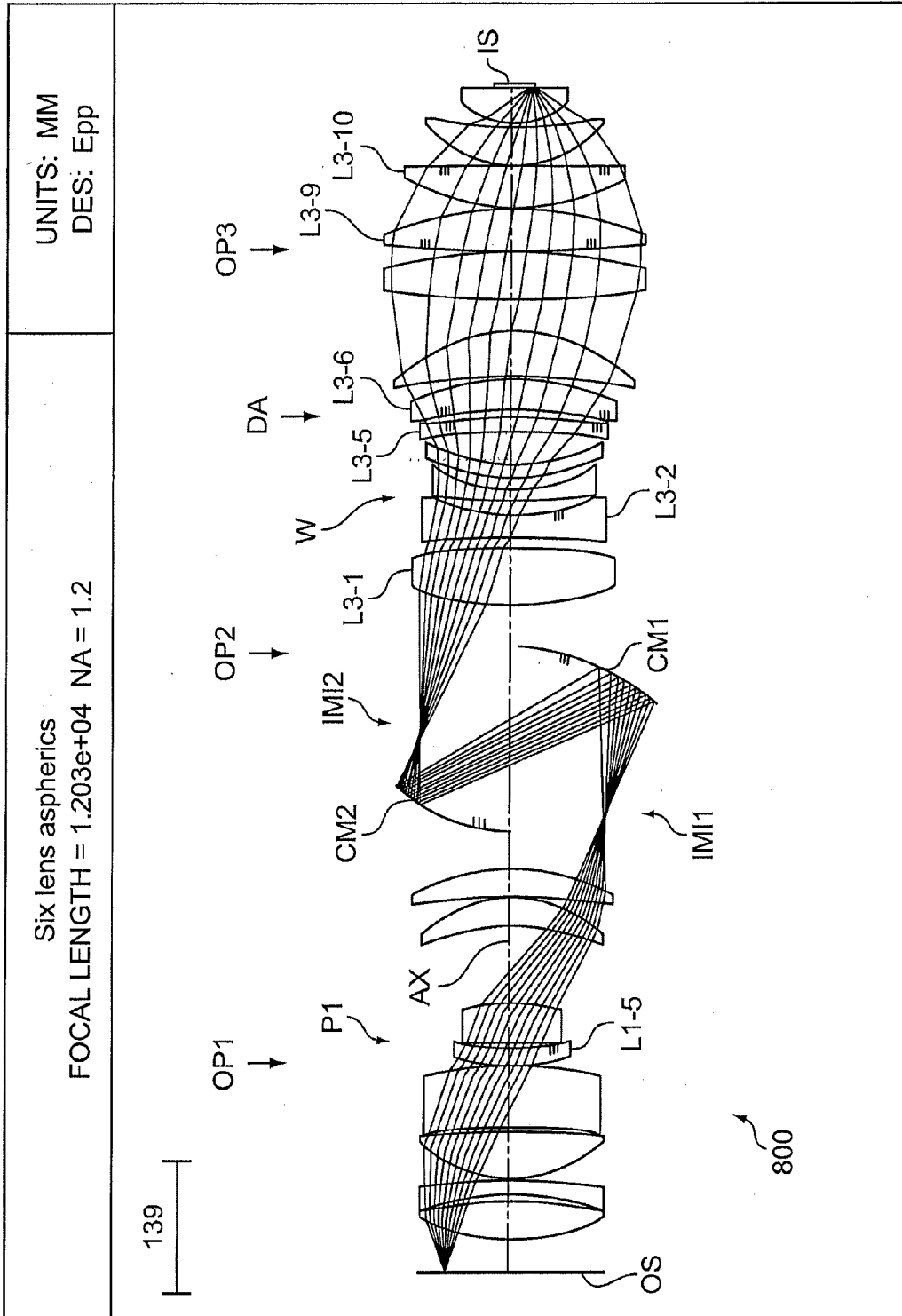

FIG. 8

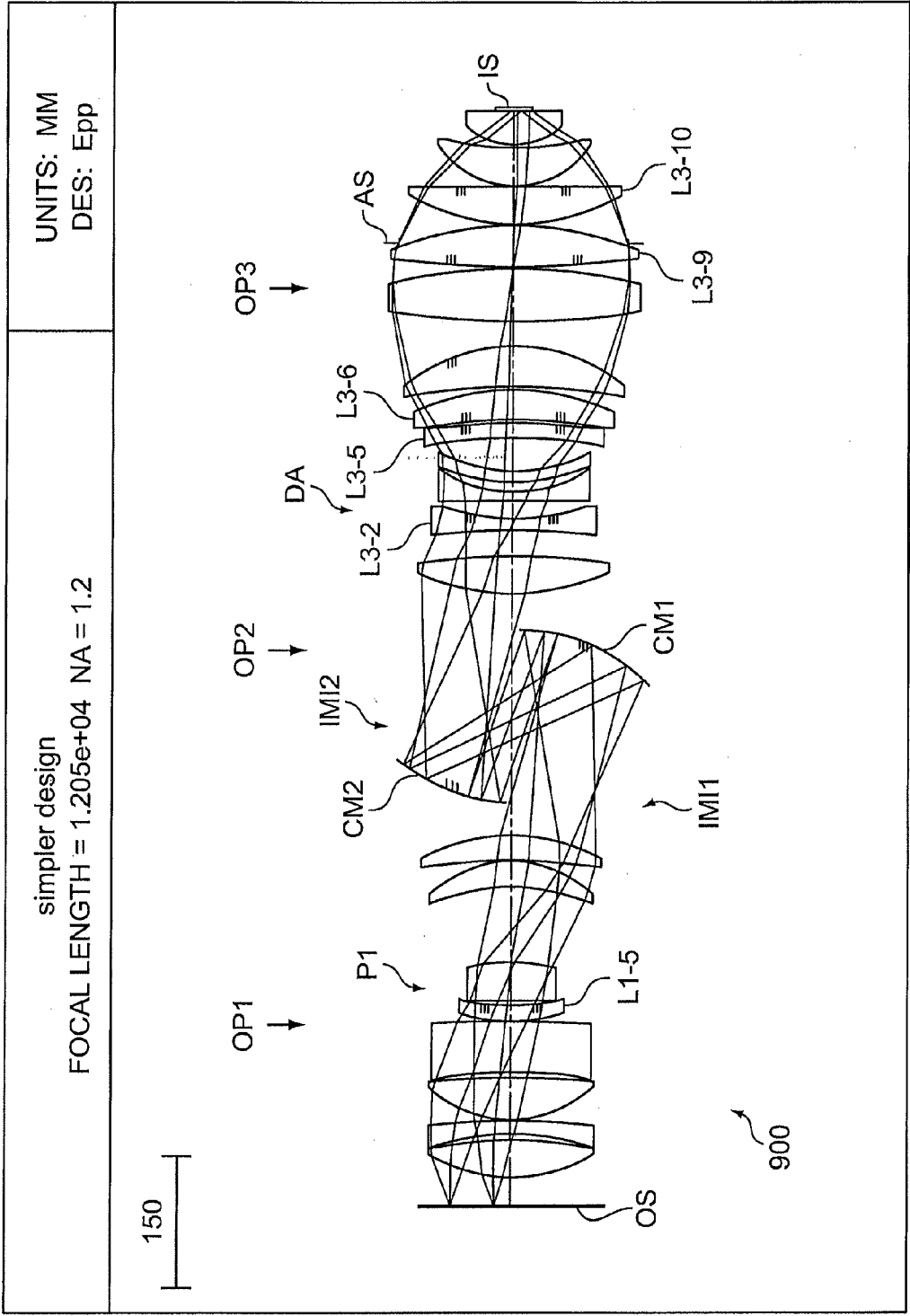
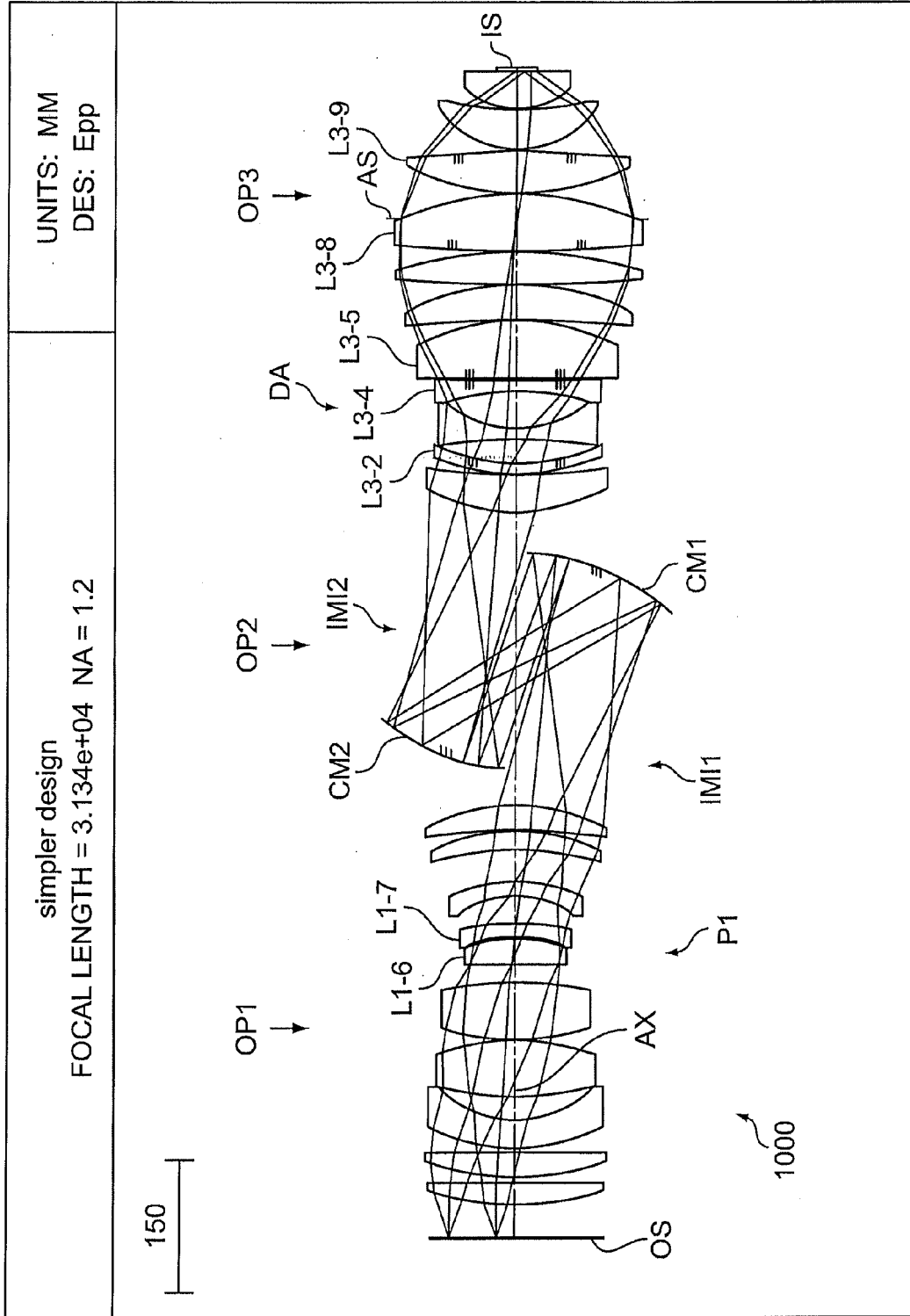

FIG. 9



simpler design

FOCAL LENGTH = 3.134e+04 NA = 1.2

UNITS: MM
DES: Epp

FIG. 10

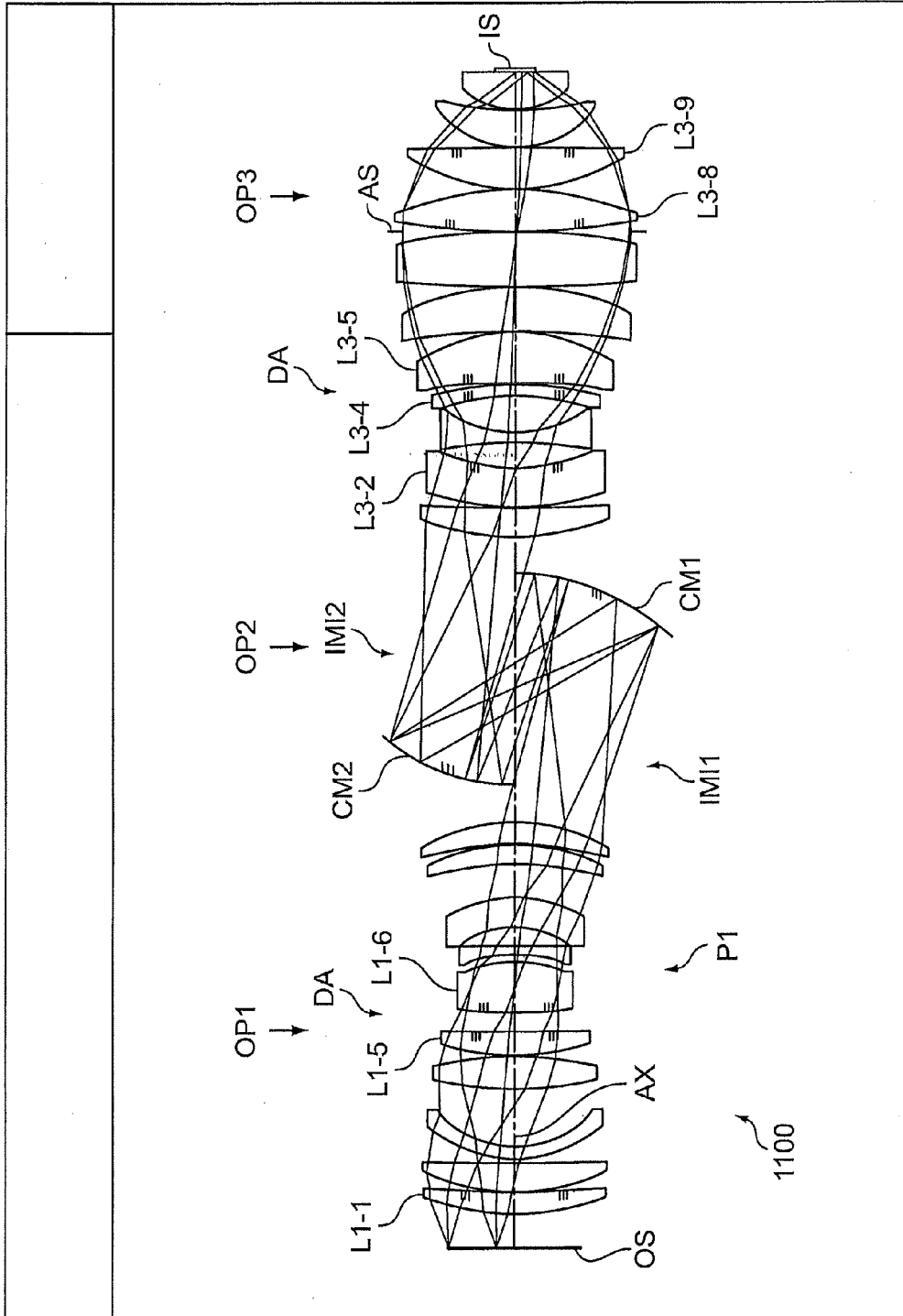

FIG. 11

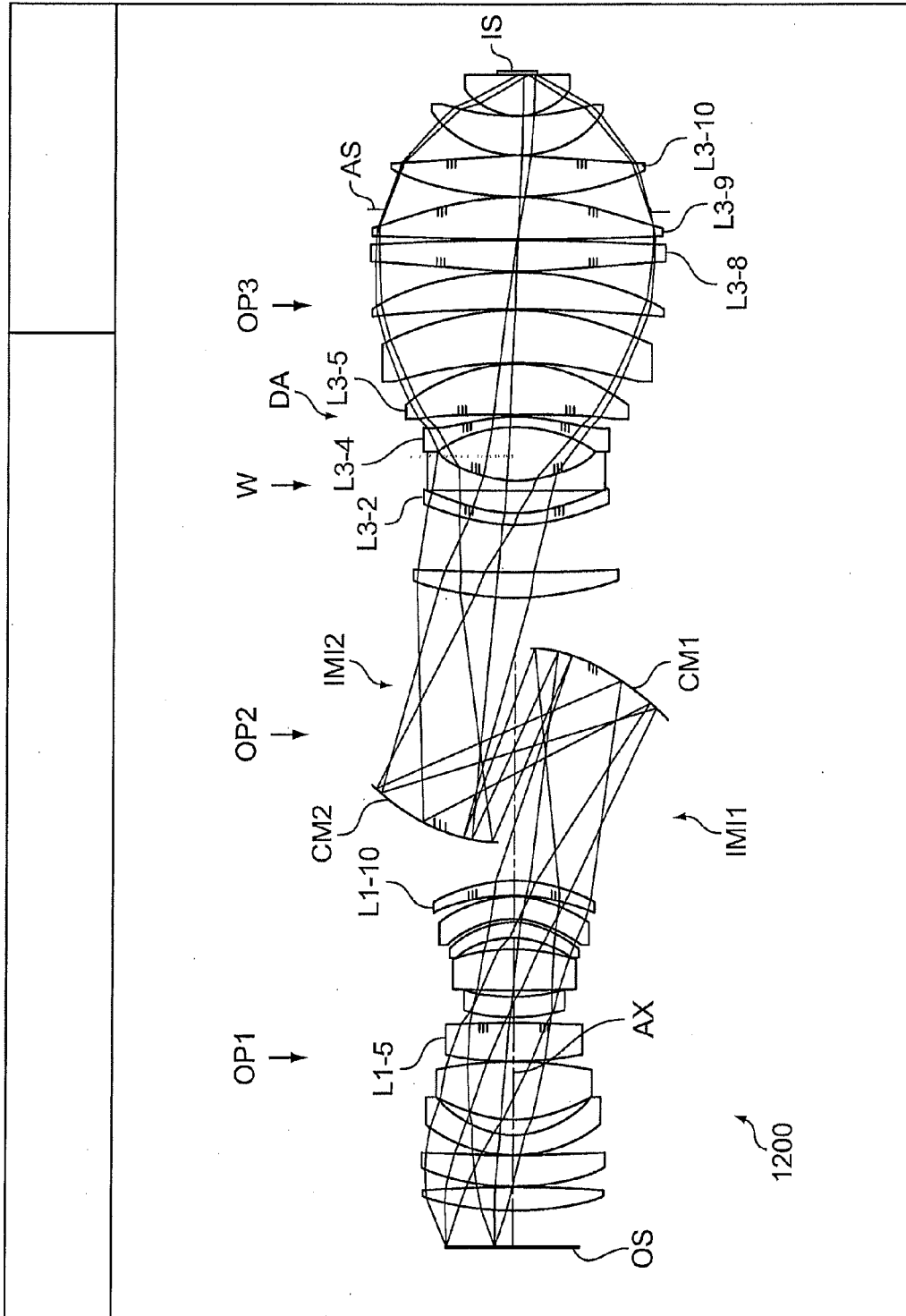

FIG. 12

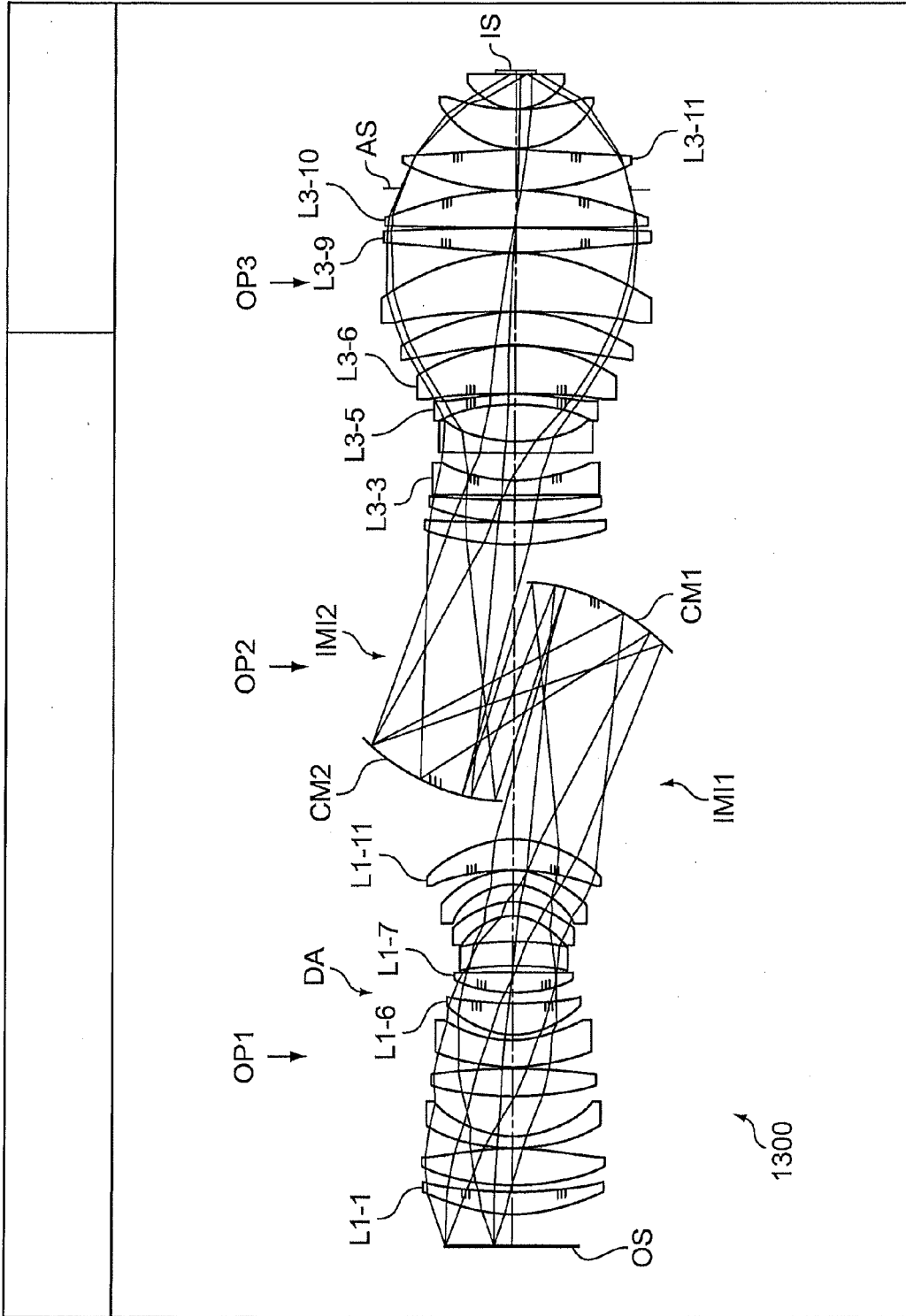

FIG. 13

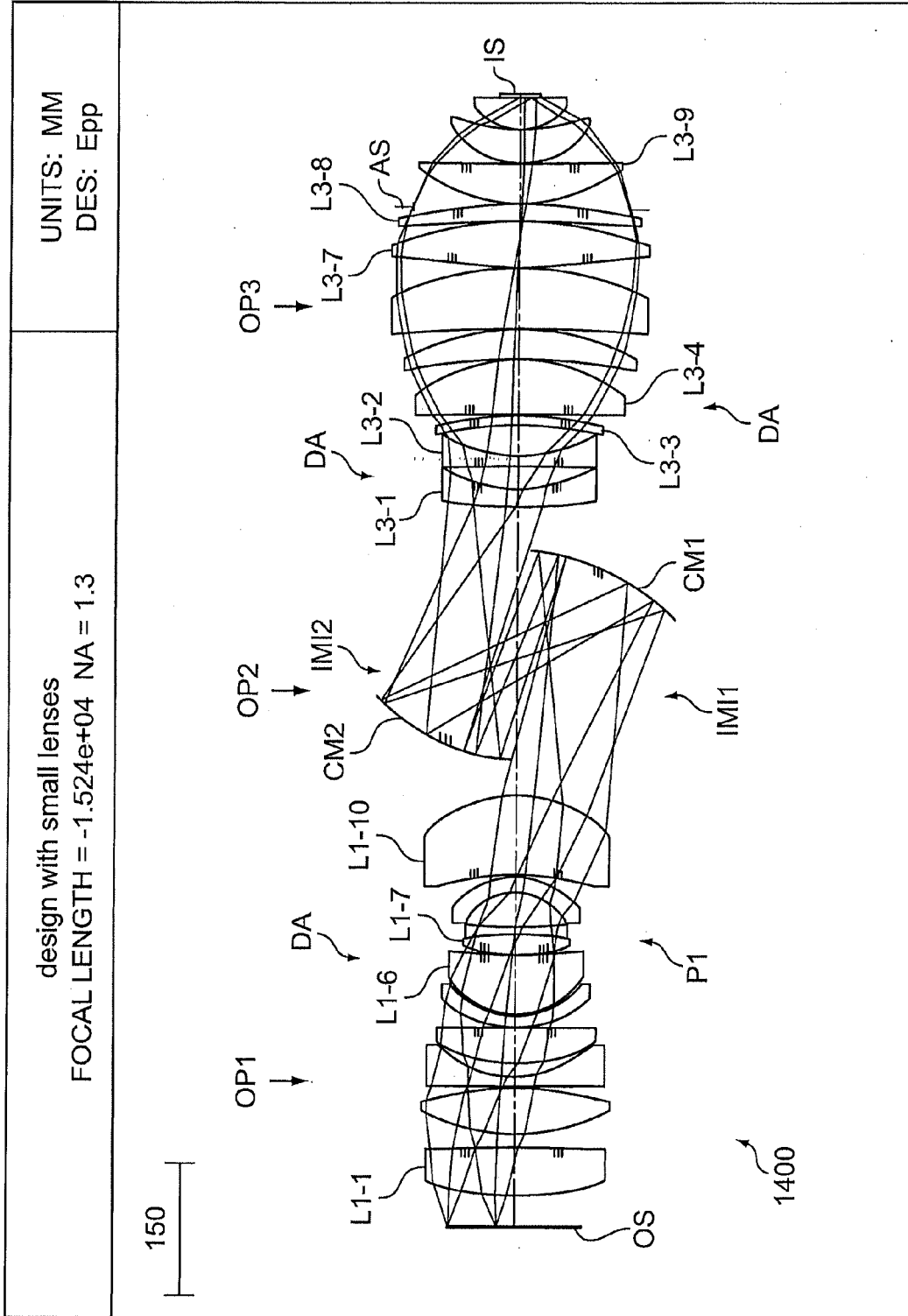

FIG. 14

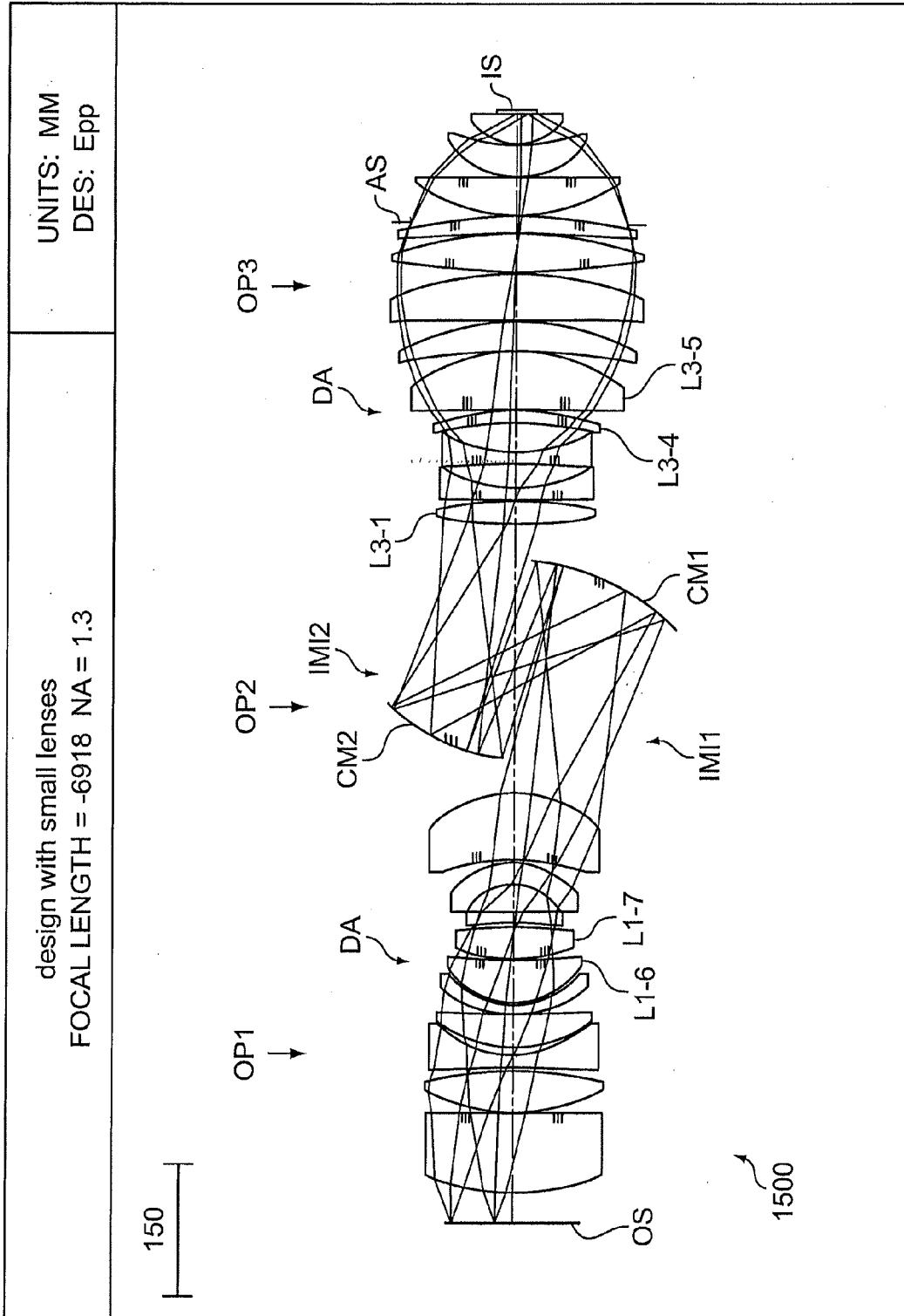

FIG. 15

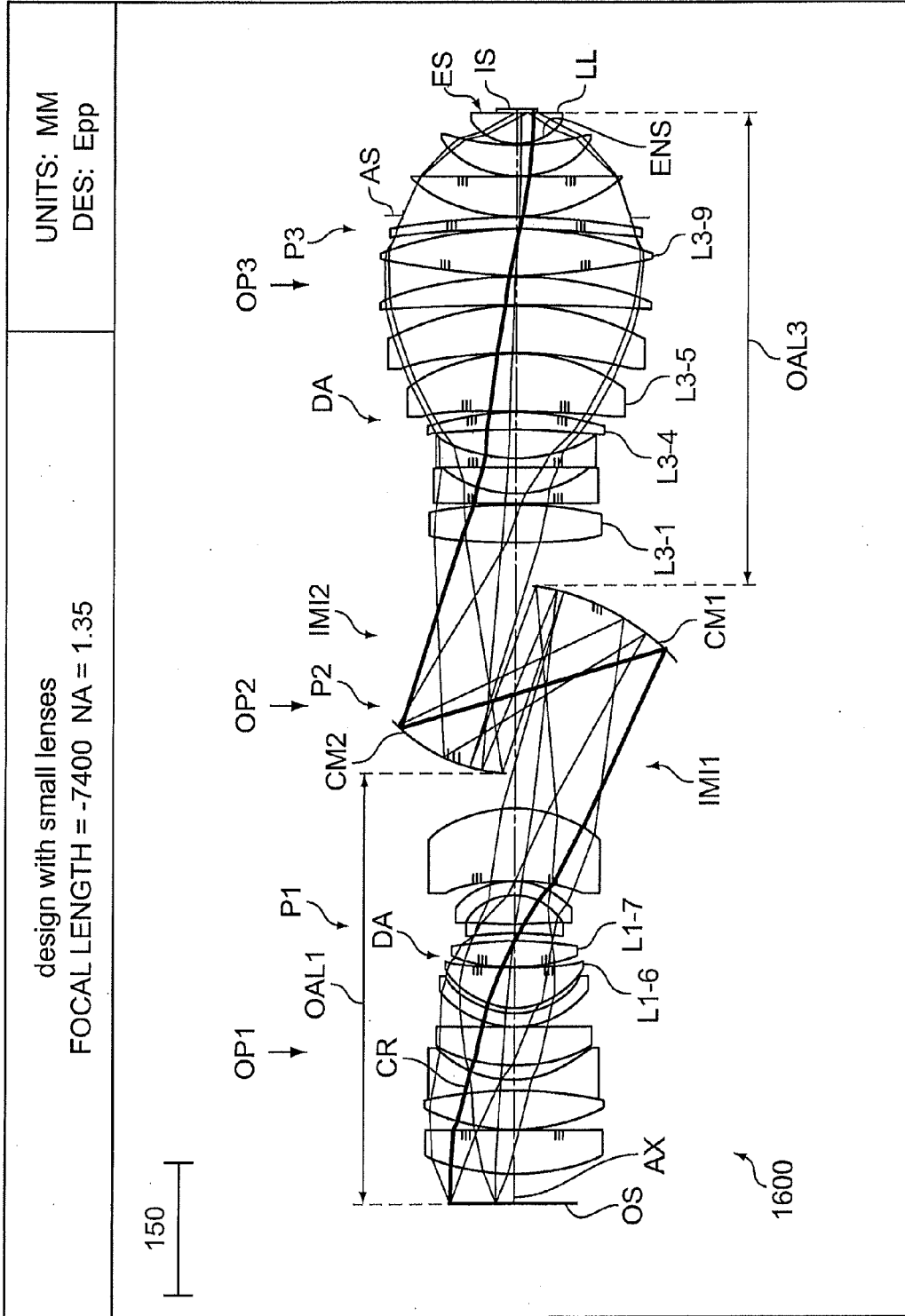

FIG. 16

CATADIOPTRIC PROJECTION OBJECTIVE

CROSS-REFERENCE TO RELATED APPLICATIONS

[0001] This application is a continuation of U.S. application Ser. No. 11/653,366, filed Jan. 16, 2007, which is a continuation-in-part of International Application PCT/EP2005/007431, filed Jul. 8, 2005, which claims benefit of U.S. Provisional Applications 60/587,504, filed Jul. 14, 2004, 60/591,775, filed Jul. 27, 2004, 60/612,823, filed Sep. 24, 2004, 60/617,674, filed Oct. 13, 2004, 60/654,950, filed Feb. 23, 2005, and is further a continuation-in-part of U.S. application Ser. No. 11/035,103, filed Jan. 14, 2005, now U.S. Pat. No. 7,385,756. U.S. application Ser. No. 11/035,103 claims benefit of U.S. Provisional Applications 60/536,248, 60/587,504, 60/591,775, 60/612,823, and 60/617,674. The disclosures of each of these related applications are hereby incorporated by reference into the present continuation application.

BACKGROUND OF THE INVENTION

[0002] 1. Field of the Invention

[0003] The invention relates to a catadioptric projection objective for imaging a pattern arranged in an object surface onto an image surface.

[0004] 2. Description of the Related Art

[0005] Projection objectives of that type are employed on projection exposure systems, in particular wafer scanners or wafer steppers, used for fabricating semiconductor devices and other types of microdevices and serve to project patterns on photomasks or reticles, hereinafter referred to generically as "masks" or "reticles," onto an object having a photosensitive coating with ultrahigh resolution on a reduced scale.

[0006] In order to create even finer structures, it is sought to both increase the image-end numerical aperture (NA) of the projection objective to be involved and employ shorter wavelengths, preferably ultraviolet light with wavelengths less than about 260 nm.

[0007] However, there are very few materials, in particular, synthetic quartz glass and crystalline fluorides, that are sufficiently transparent in that wavelength region available for fabricating the optical elements required. Since the Abbé numbers of those materials that are available lie rather close to one another, it is difficult to provide purely refractive systems that are sufficiently well color-corrected (corrected for chromatic aberrations).

[0008] In lithography, a flat (planar) image is essential to expose planar substrates, such as semiconductor wafers. However, generally the image surface of an optical system is curved, and the degree of curvature is determined by the Petzval sum. The correction of the Petzval sum is becoming more important in view of the increasing demands to project large object fields on planar surfaces with increased resolution.

[0009] One approach for obtaining a flat image surface and good color-correction is the use of catadioptric systems, which combine both refracting elements, such as lenses, and reflecting elements, such as mirror, preferably including at least one concave mirror. While the contributions of positive-powered and negative-powered lenses in an optical system to overall power, surface curvature and chromatic aberrations are opposite to each other, a concave mirror has positive

power like a positive-powered lens, but the opposite effect on surface curvature without contributing to chromatic aberrations.

[0010] Further, the high prices of the materials involved and limited availability of crystalline calcium fluoride in sizes large enough for fabricating large lenses represent problems. Measures that will allow reducing the number and sizes of lenses and simultaneously contribute to maintaining, or even improving, imaging fidelity are thus desired.

[0011] Catadioptric projection objectives having at least two concave mirrors have been proposed to provide systems with good color correction and moderate lens mass requirements. The U.S. Pat. No. 6,600,608 B1 discloses a catadioptric projection objective having a first, purely refractive objective part for imaging a pattern arranged in the object plane of the projection objective into a first intermediate image, a second objective part for imaging the first intermediate image into a second intermediate image and a third objective part for imaging the second intermediate image directly, that is without a further intermediate image, onto the image plane. The second objective part is a catadioptric objective part having a first concave mirror with a central bore and a second concave mirror with a central bore, the concave mirrors having the mirror faces facing each other and defining an intermirror space or catadioptric cavity in between. The first intermediate image is formed within the central bore of the concave mirror next to the object plane, whereas the second intermediate image is formed within the central bore of the concave mirror next to the object plane. The objective has axial symmetry and provides good color correction axially and laterally. However, since the reflecting surfaces of the concave mirrors are interrupted at the bores, the pupil of the system is obscured.

[0012] The Patent EP 1 069 448 B1 discloses another catadioptric projection objective having two concave mirrors facing each other. The concave mirrors are part of a first catadioptric objective part imaging the object onto an intermediate image positioned adjacent to a concave mirror. This is the only intermediate image, which is imaged to the image plane by a second, purely refractive objective part. The object as well as the image of the catadioptric imaging system are positioned outside the intermirror space defined by the mirrors facing each other. Similar systems having two concave mirrors, a common straight optical axis and one intermediate image formed by a catadioptric imaging system and positioned besides one of the concave mirrors are disclosed in Japanese patent application JP 2002208551 A and US patent application US 2002/00241 A1.

[0013] European patent application EP 1 336 887 (corresponding to US 2004/0130806 A1) discloses catadioptric projection objectives having one common straight optical axis and, in that sequence, a first catadioptric objective part for creating a first intermediate image, a second catadioptric objective part for creating a second intermediate image from the first intermediate image, and a refractive third objective part forming the image from the second intermediate image. Each catadioptric system has two concave mirrors facing each other. The intermediate images lie outside the intermirror spaces defined by the concave mirrors. Concave mirrors are positioned optically near to pupil surfaces closer to pupil surfaces than to the intermediate images of the projection objectives.

[0014] International Patent application WO 2004/107011 A1 discloses catadioptric projection objectives having one

common straight optical axis and two or more intermediate images and suitable for immersion lithography with numerical apertures up to $NA=1.2$. At least one concave mirror is positioned optically near to a pupil surface closer to that pupil surface than to an intermediate images of the projection objective.

[0015] In the article "Nikon Projection Lens Update" by T. Matsuyama, T. Ishiyama and Y. Ohmura, presented by B. W. Smith in: Optical Microlithography XVII, Proc. of SPIE 5377.65 (2004) a design example of a catadioptric projection lens is shown, which is a combination of a conventional dioptric DUV system and a 6-mirror EUV catoptric system inserted between lens groups of the DUV system. A first intermediate image is formed behind the third mirror of the catoptric (purely reflective) group upstream of a convex mirror. The second intermediate image is formed by a purely reflective (catoptric) second objective part. The third objective part is purely refractive featuring negative refractive power at a waist of minimum beam diameter within the third objective part for Petzval sum correction.

[0016] Japanese patent application JP 2003114387 A and international patent application WO 01/55767 A disclose catadioptric projection objectives having one common straight optical axis, a first catadioptric objective part for forming an intermediate image and a second catadioptric objective part for imaging the intermediate image onto the image plane of this system. Concave and convex mirrors are used in combination.

[0017] The article "Camera view finder using tilted concave mirror erecting elements" by D. DeJager, SPIE. Vol. 237 (1980) p. 292-298 discloses camera view finders comprising two concave mirrors as elements of a 1:1 telescopic erecting relay system. The system is designed to image an object at infinity into a real image, which is erect and can be viewed through an eyepiece. Separate optical axes of refractive system parts upstream and downstream of the catoptric relay system are parallel offset to each other. In order to build a system having concave mirrors facing each other mirrors must be tilted. The authors conclude that physically realizable systems of this type have poor image quality.

[0018] International patent applications WO 92/05462 and WO 94/06047 and the article "Innovative Wide-Field Binocular Design" in OSA/SPIE Proceedings (1994) pages 389ff disclose catadioptric optical systems especially for binoculars and other viewing instruments designed as inline system having a single, unfolded optical axis. Some embodiments have a first concave mirror having an object side mirror surface arranged on one side of the optical axis and a second concave mirror having a mirror surface facing the first mirror and arranged on the opposite side of the optical axis such that the surface curvatures of the concave mirrors define and inter-mirror space. A front refractive group forms a first intermediate image near the first mirror and a second intermediate image is formed outside of the space formed by the two facing mirrors. A narrow field being larger in a horizontal direction than in a vertical direction is arranged offset to the optical axis. The object side refractive group has a collimated input and the image side refractive group has a collimated output and entrance and exit pupils far from telecentric are formed. The pupil shape is semi-circular unlike pupil surfaces in lithographic projection lenses, which have to be circular and centered on the optical axis.

[0019] The PCT application WO 01/044682 A1 discloses catadioptric UV imaging systems for wafer inspection having one concave mirror designed as Mangin mirror.

[0020] Catadioptric projection objectives consisting of a catadioptric imaging subsystem having one single concave mirror and arranged between an entry side and an exit side refractive imaging subsystem (so-called R-C-R systems) are disclosed, for example, in U.S. application with Ser. No. 60/573,533 filed on May 17, 2004 by the applicant. Other examples of R-C-R-systems are shown in US 2003/0011755, WO 03/036361 or US 2003/0197946.

[0021] US patent application with title "Catadioptric Projection Objective" filed by the applicant on Jan. 14, 2005 (based on U.S. provisional applications 60/536,248 filed on Jan. 14, 2004; U.S., **60/587,504** filed Jul. 14, 2004; 60/617,674 filed Oct. 13, 2004; 60/591,775 filed Jul. 27, 2004; and 60/612,823 filed Sep. 24, 2004) discloses catadioptric projection objectives having very high NA and suitable for immersion lithography at $NA>1$ with maximum values $NA=1.2$. The projection objectives comprise: a first objective part for imaging the pattern provided in the object plane into a first intermediate image, a second objective part for imaging the first intermediate image into a second intermediate image, and a third objective part for imaging the second intermediate image directly onto the image plane. The second objective part includes a first concave mirror having a first continuous mirror surface and a second concave mirror having a second continuous mirror surface, the concave mirror faces facing each other and defining an intermirror space. All concave mirrors are positioned optically remote from pupil surfaces. The system has potential for very high numerical apertures at moderate lens mass consumption. The full disclosure of this document and the priority documents thereof is incorporated into the present application by reference.

SUMMARY OF THE INVENTION

[0022] It is one object of the invention to provide a catadioptric projection objective suitable for use in the vacuum ultraviolet (VUV) range having potential for very high image side numerical aperture which may be extended to values allowing immersion lithography at numerical apertures $NA>1$. It is another object to provide catadioptric projection objectives that can be build with relatively small amounts of optical material. It is yet another object to provide compact high-aperture catadioptric projection objectives having moderate size.

[0023] As a solution to these and other objects the invention, according to one formulation, provides a catadioptric projection objective for imaging a pattern provided in an object surface of the projection objective onto an image surface of the projection objective comprising:

a first, refractive objective part for imaging the pattern provided in the object plane into a first intermediate image;

a second objective part including at least one concave mirror for imaging the first intermediate image into a second intermediate image;

a third, refractive objective part for imaging the second intermediate image onto the image plane; wherein:

the projection objective has a maximum lens diameter D_{max} , a maximum image field height Y' , and an image side numerical aperture NA; wherein

$$COMP1 = D_{max} / (Y' \cdot NA^2)$$

and wherein the following condition holds:

$$\text{COMP1} < 10$$

[0024] Generally, the dimensions of projection objectives tend to increase dramatically as the image side numerical aperture NA is increased. Empirically it has been found that the maximum lens diameter D_{max} tends to increase stronger than linear with increase of NA according to $D_{max} \sim \text{NA}^k$, where $k > 1$. A value $k=2$ is an approximation used for the purpose of this application. Further, it has been found that the maximum lens diameter D_{max} increases in proportion to the image field size (represented by the image field height Y'). A linear dependency is assumed for the purpose of the application. Based on these considerations a first compactness parameter COMP1 is defined as:

$$\text{COMP1} = D_{max} / (Y' \cdot \text{NA}^2).$$

[0025] It is evident that, for given values of image field height and numerical aperture, the first compaction parameter COMP1 should be as small as possible if a compact design is desired.

[0026] Considering the overall material consumption necessary for providing a projection objective, the absolute number of lenses, N_L is also relevant. Typically, systems with a smaller number of lenses are preferred to systems with larger numbers of lenses. Therefore, a second compactness parameter COMP2 is defined as follows:

$$\text{COMP2} = \text{COMP1} \cdot N_L.$$

[0027] Again, small values for COMP2 are indicative of compact optical systems.

[0028] Further, projection objectives according to the invention have at least three objective parts for imaging an entry side field plane into an optically conjugate exit side field plane, where the imaging objective parts are concatenated at intermediate images. Typically, the number of lenses and the overall material necessary to build a projection objective will increase the higher the number N_{OP} of imaging objective parts of the optical system is. It is desirable to keep the average number of lenses per objective part, N_L / N_{OP} , as small as possible. Therefore, a third compactness parameter COMP3 is defined as follows:

$$\text{COMP3} = \text{COMP1} \cdot N_L / N_{OP}.$$

[0029] Again, projection objectives with low optical material consumption will be characterized by small values of COMP3.

[0030] A value $\text{COMP1} < 10$ indicates a very compact design. Even values of $\text{COMP1} < 9.6$ are obtained in some embodiments. In some embodiments the low compactness is obtained although the numerical aperture is larger than 1.2 (i.e. $\text{NA} > 1.2$). Embodiments with $\text{NA} = 1.3$ or $\text{NA} = 1.35$ are possible and allow ultra-high resolution immersion lithography.

[0031] In some embodiments, low values for the second compactness parameter can be obtained. In some embodiments $\text{COMP2} < 260$ and/or $\text{COMP2} < 240$ is obtained. Embodiments with $\text{COMP2} < 220$ are possible.

[0032] Alternatively, or in addition, low values for the third compactness parameter COMP3 are possible. In some embodiments $\text{COMP3} < 80$, and lower values of $\text{COMP3} < 70$ are also possible.

[0033] In preferred embodiments, a first concave mirror having a first continuous mirror surface and at least one second concave mirror having a second continuous mirror

surface are arranged in the second objective part; pupil surfaces are formed between the object plane and the first intermediate image, between the first and the second intermediate image and between the second intermediate image and the image plane; and all concave mirrors are arranged optically remote from a pupil surface.

[0034] In these embodiments a circular pupil centered around the optical axis is provided in a centered optical system. Two or more concave mirrors in the system parts contributing to forming the second intermediate image are provided, where the used area of the concave mirrors deviates significantly from an axial symmetric illumination. In preferred embodiments exactly two concave mirrors are provided and are sufficient for obtaining excellent imaging quality and very high numerical aperture. Systems having one common unfolded (straight) optical axis can be provided which facilitate manufacturing, adjustment and integration into photolithographic exposure systems. No planar folding mirrors are necessary. However, one or more planar folding mirrors could be utilized to obtain more compact designs.

[0035] All concave mirrors are arranged "optically remote" from pupil surfaces which means that they are arranged outside an optical vicinity of a pupil surface. They may be arranged optically nearer to field surfaces than to pupil surfaces. Preferred positions optically remote from a pupil surface (i.e. outside an optical vicinity of a pupil surface) may be characterized by the ray height ratio $H = h_C / h_M > 1$, where h_C is the height of a chief ray and h_M is the height of a marginal ray of the imaging process. The marginal ray height h_M is the height of a marginal ray running from an inner field point (closest to the optical axis) to the edge of an aperture stop, whereas the chief ray height h_C is the height of a chief ray running from an outermost field point (farthest away from the optical axis) parallel to or at small angle with respect to the optical axis and intersecting the optical axis at a pupil surface position where an aperture stop may be positioned. With other words: all concave mirrors are in positions where the chief ray height exceeds the marginal ray height.

[0036] A position "optically remote" from a pupil surface is a position where the cross sectional shape of the light beam deviates significantly from the circular shape found in a pupil surface or in an immediate vicinity thereto. The term "light beam" as used here describes the bundle of all rays running from the object surface to the image surface. Mirror positions optically remote from a pupil surface may be defined as positions where the beam diameters of the light beam in mutually perpendicular directions orthogonal to the propagation direction of the light beam deviate by more than 50% or 100% from each other. In other words, illuminated areas on the concave mirrors may have a shape having a form strongly deviating from a circle and similar to a high aspect ratio rectangle corresponding to a preferred field shape in lithographic projection objectives for wafer scanners. Therefore, small concave mirrors having a compact rectangular or near rectangular shape significantly smaller in one direction than in the other may be used. A high aperture light beam can therefore be guided through the system without vignetting at mirror edges.

[0037] Throughout the specification, the term "objective part" designates an imaging subsystem of the projection objective capable of imaging an object in an object surface of that subsystem into an image surface of the subsystem optically conjugated to the object surface of the subsystem. The

object imaged by a subsystem (or objective part) may be the object in the object surface of the projection objective, or an intermediate image.

[0038] Wherever the terms “upstream” or “downstream” are used in this specification these terms refer to relative positions along the optical path of a light beam running from the object plane to the image plane of the projection objective. Therefore, a position upstream of the second intermediate image is a position optically between the object plane and the second intermediate image.

[0039] The term “intermediate image” generally refers to a “paraxial intermediate image” formed by a perfect optical system and located in a surface optically conjugated to the object surface. Therefore, wherever reference is made to a location or position of an intermediate image, the axial location of this surface optically conjugated to the object surface is meant.

[0040] According to another aspect of the invention, a catadioptric projection objective for imaging a pattern provided in an object surface of the projection objective onto an image surface of the projection objective comprises:

a first, refractive objective part for imaging the pattern provided in the object surface into a first intermediate image;

a second objective part for imaging the first intermediate image into a second intermediate image;

a third, refractive objective part for imaging the second intermediate image onto the image surface;

wherein a first concave mirror having a first continuous mirror surface and at least one second concave mirror having a second continuous mirror surface are arranged upstream of the second intermediate image;

pupil surfaces are formed between the object plane and the first intermediate image, between the first and the second intermediate image and between the second intermediate image and the image plane;

all concave mirrors are arranged optically remote from a pupil surface; the first objective part has a first number $N1_{AS}$ of aspheric lenses;

the third objective part has a second number $N3_{AS}$ of aspheric lenses;

an aspheric lens ratio $ASR=N1_{AS}/N3_{AS}$ is smaller than 1; and an image side numerical aperture NA is larger than 1.2.

[0041] Although it would be desired from a manufacturing point of view to have lenses with spherical lens surfaces only, it appears that a certain number of aspheric lenses are required to obtain sufficient correction of image aberrations. It has been found that in designs where the third objective part has more aspheric lenses than the first objective part have potential for obtaining a good correction status without increasing the overall number, N_{AS} , of aspheric lenses in the projection objective above a critical limit where the manufacturing of aspheric lenses becomes a critical issue due to the high number of aspheric lenses to be manufactured.

[0042] In some embodiments the first objective part has spherical lenses only such that $N1_{AS}=0$. All-spherical refractive objective parts are particularly easy to manufacture. An all-spherical first objective part may be combined with a third objective part having one or more aspheric lenses, for example 1 or 2 or 3 or 4 or 5 lenses. Preferably the condition $N3_{AS} \leq 7$ is fulfilled.

[0043] Preferably, the first objective part has no more than 4 aspheric lenses, i.e. $N1_{AS} \leq 4$.

[0044] It has been found that the first objective part can be built in many cases with a small number of lenses, thereby

optimizing lens material consumption and a compact size of the first objective part particularly in axial direction. In some embodiments, the first objective part includes no more than 5 lenses such that the number $N1_L$ of lenses in the first objective part fulfills the condition $N1_L \leq 5$. Embodiments with $N1_L=4$ are possible. It appears, however, that $N1_L=5$ may be preferable in many cases.

[0045] In some embodiments, the first objective part has positive lenses only, whereby formation of the first intermediate image can be obtained with small maximum lens diameters in the first objective part. In other embodiments, at least one negative lens may be useful, particularly for improving correction within the first objective part. Exactly one negative lens is often preferred for that purpose. The negative lens may have a concave lens surface on the image side and may be placed between the pupil surface of the first objective part and the first intermediate image.

[0046] It is known that aspheric surfaces provided on optical elements, such as lenses, mirrors and/or essentially planar faces of plates, prisms or the like can be utilized to improve both the correction status and the overall size and material consumption of optical systems. In some embodiments, the projection objective includes at least one “double asphere” comprising a first aspheric surface and a second aspheric surface immediately adjacent to the first aspheric surface, thereby allowing a transmitted beam to pass two subsequent aspheric surfaces without passing an intermediate spheric or planar surface. Double aspheres have proven to be a very powerful correction means in some embodiments.

[0047] A double asphere may take the structure of a bi-aspherical lens having an aspheric entrance surface and an aspheric exit surface. In some preferred embodiments the double asphere is formed by facing adjacent aspheric surfaces of two subsequent lenses. Thereby, an “air space” bounded by aspheric surfaces on both the entry and exit side can be obtained. The “air space” can be filled with air or another gas having refractive index $n \approx 1$. Where aspheric surfaces of a double asphere are distributed on facing lens surfaces of subsequent lenses, the aspheric surfaces can be positioned very close together if desired. An optical distance, measured along the optical axis, between the first and second aspheric surface of the double asphere may therefore be smaller than the thickness (measured along the optical axis) of the thinner one of consecutive lenses forming the double asphere. A complex radial distribution of refractive power can thereby be obtained at a defined position in an axially narrow region along the optical axis.

[0048] In some embodiments, the third objective part includes at least one double asphere. Preferably, that double asphere is positioned optically between the second intermediate image and the pupil surface of the third objective part, thereby preferably influencing the ray angles in a region of generally diverging beams. A second double asphere may be provided in that objective part.

[0049] Alternatively, or in combination, the first objective part may include at least one double asphere. Where a double asphere is provided within the first objective part, it has been found beneficial when the double asphere in the first objective part is positioned optically close to or at a pupil surface of the first objective part.

[0050] As pointed out earlier, avoiding large numbers of aspheric surfaces on lenses may contribute to facilitating manufacturing of the projection objective. Under certain conditions, the correcting action of a single aspheric surface can

be approximated by one or more spherical surfaces where large angles of incidence of rays occur on that surface. In some embodiments, the first objective part includes at least one lens having a lens surface where incidence angles of rays transiting that lens surface include incidence angles larger than 60° . Preferably, that surface may be optically close to the pupil surface. The angle of incidence (incidence angle) in this case is defined as the angle enclosed by a ray and the surface normal of the lens surface at the point of impingement of that ray on the lens surface. High incidence angle surfaces of that kind may be employed to reduce the number of aspheres.

[0051] The previous and other properties can be seen not only in the claims but also in the description and the drawings, wherein individual characteristics may be used either alone or in sub-combinations as an embodiment of the invention and in other areas and may individually represent advantageous and patentable embodiments.

BRIEF DESCRIPTION OF THE DRAWINGS

[0052] FIG. 1 is a longitudinally sectioned view of a first embodiment of a projection objective according to the invention;

[0053] FIG. 2 is a longitudinally sectioned view of a second embodiment of a projection objective according to the invention;

[0054] FIG. 3 is a longitudinally sectioned view of a third embodiment of a projection objective according to the invention;

[0055] FIG. 4 is a longitudinally sectioned view of a fourth embodiment of a projection objective according to the invention;

[0056] FIG. 5 is a longitudinally sectioned view of a fifth embodiment of a projection objective according to the invention;

[0057] FIG. 6 is a longitudinally sectioned view of a sixth embodiment of a projection objective according to the invention;

[0058] FIG. 7 is a longitudinally sectioned view of a seventh embodiment of a projection objective according to the invention;

[0059] FIG. 9 is a longitudinally sectioned view of a ninth embodiment of a projection objective according to the invention;

[0060] FIG. 10 is a longitudinally sectioned view of a tenth embodiment of a projection objective according to the invention;

[0061] FIG. 11 is a longitudinally sectioned view of an eleventh embodiment of a projection objective according to the invention;

[0062] FIG. 12 is a longitudinally sectioned view of a twelfth embodiment of a projection objective according to the invention;

[0063] FIG. 13 is a longitudinally sectioned view of a thirteenth embodiment of a projection objective according to the invention;

[0064] FIG. 14 is a longitudinally sectioned view of a fourteenth embodiment of a projection objective according to the invention;

[0065] FIG. 15 is a longitudinally sectioned view of a fifteenth embodiment of a projection objective according to the invention;

[0066] FIG. 16 is a longitudinally sectioned view of a sixteenth embodiment of a projection objective according to the invention.

DETAILED DESCRIPTION OF THE PREFERRED EMBODIMENTS

[0067] In the following description of preferred embodiments of the invention, the term “optical axis” shall refer to a straight line or sequence of straight-line segments passing through the centers of curvature of the optical elements involved. The optical axis is folded by folding mirrors (deflecting mirrors) or other reflective surfaces. In the case of those examples presented here, the object involved is either a mask (reticle) bearing the pattern of an integrated circuit or some other pattern, for example, a grating pattern. In the examples presented here, the image of the object is projected onto a wafer serving as a substrate that is coated with a layer of photoresist, although other types of substrate, such as components of liquid-crystal displays or substrates for optical gratings, are also feasible.

[0068] Where tables are provided to disclose the specification of a design shown in a figure, the table or tables are designated by the same numbers as the respective figures. Corresponding features in the figures are designated with like or identical reference identifications to facilitate understanding. Where lenses are designated, an identification L3-2 denotes the second lens in the third objective part (when viewed in the light propagation direction).

[0069] FIG. 1 shows a first embodiment of a catadioptric projection lens 100 according to the invention designed for ca. 193 nm UV working wavelength. It is designed to project an image of a pattern on a reticle arranged in the planar object surface OS (object plane) into the planar image surface IS (image plane) on a reduced scale, for example, 4:1, while creating exactly two real intermediate images IMI1, IMI2. A first refractive objective part OP1 is designed for imaging the pattern in the object surface into the first intermediate image IMI1 at an enlarged scale. A second, catoptric (purely reflective) objective part OP2 images the first intermediate image IMI1 into the second intermediate image IMI2 at a magnification close to 1:1. A third, refractive objective part OP3 images the second intermediate image IMI2 onto the image surface IS with a strong reduction ratio. The second objective part OP2 comprises a first concave mirror CM1 having the concave mirror surface facing the object side, and a second concave mirror CM2 having the concave mirror surface facing the image side. The mirror surfaces are both continuous or unbroken, i.e. they do not have a hole or bore. The mirror surfaces facing each other define a catadioptric cavity, which is also denoted intermirror space, enclosed by the curved surfaces defined by the concave mirrors. The intermediate images IMI1, IMI2 are both situated inside the catadioptric cavity well apart from the mirror surfaces.

[0070] Each mirror surface of a concave mirror defines a “curvature surface” or “surface of curvature” which is a mathematical surface extending beyond the edges of the physical mirror surface and containing the mirror surface. The first and second concave mirrors are parts of rotationally symmetric curvature surfaces having a common axis of rotational symmetry.

[0071] The objective 100 is rotational symmetric and has one straight optical axis AX common to all refractive and reflective optical components. There are no folding mirrors. The concave mirrors have small diameters allowing to bring

them close together and rather close to the intermediate images lying in between. The concave mirrors are both constructed and illuminated as off-axis sections of axial symmetric surfaces. The light beam passes by the edges of the concave mirrors facing the optical axis without vignetting.

[0072] The projection objective **100** is designed as an immersion objective for $\lambda=193$ nm having an image side numerical aperture NA=1.2 when used in conjunction with the high index immersion fluid, e.g. pure water, between the exit surface of the objective closest to the image surface IS, and the image surface IS. The refractive first objective part OP1 has spherical lenses only. Both concave mirrors CM1, CM2 are aspherical mirrors. The third objective part OP3 has one aspheric surface (entrance surface of lens L3-9) near the position of the pupil surface P3 of that objective part (where the chief ray CR of the imaging intersects the optical axis AX) and a second aspheric surface on the exit side of the penultimate lens L3-12 immediately upstream of the last, image side plano-convex lens L3-13. The last lens, which will be in contact with an immersion fluid during operation of the projection objective, is also denoted “immersion lens” in this specification. Although the projection objective is not fully corrected for all aberrations, it shows that an imaging is possible with a small number of aspheric lenses ($N_{AS}=2$) all placed in the third objective part.

[0073] FIG. 2 shows a second embodiment of a projection objective **200** having an all-spheric first objective part OP1 and only one aspheric lens L3-4 in third objective part OP3. An aperture stop AS is placed in the third objective part in the region of the pupil surface PS3 thereof. There is no need for a well-corrected position for an aperture stop in the first objective part OP1, which, in this case, consists of only four lenses, all lenses being spherical positive lenses. Thereby, a very simple and compact construction of the first objective part is obtained.

[0074] The projection objective **200** is designed as an immersion lens for $\lambda=193$ nm having an image side numerical aperture NA=1.20 when used in conjunction with a high index immersion fluid, e.g. pure water, between the exit surface of the objective and the image surface. The specification for this design is summarized in Table 2. The leftmost column lists the number of the refractive, reflective, or otherwise designated surface, the second column lists the radius, r, of that surface [mm], the third column lists the distance, d [mm], between that surface and the next surface, a parameter that is referred to as the “thickness” of the optical element, the fourth column lists the material employed for fabricating that optical element, and the fifth column lists the refractive index of the material employed for its fabrication. The sixth column lists the optically utilizable, clear, semi diameter [mm] of the optical component. A radius r=0 in a table designates a planar surface (having infinite radius).

[0075] In the case of this particular embodiment, three surfaces (surfaces **9**, **10**, **18**) are aspherical surfaces. Table 2A lists the associated data for those aspherical surfaces, from which the sagitta or rising height p(h) of their surface figures as a function of the height h may be computed employing the following equation:

$$p(h)=[((1/r)h^2)/(1+SQRT(1-(1+K)((1/r)^2h^2)))]+C1\cdot h^4+C2\cdot h^6+\dots,$$

where the reciprocal value (1/r) of the radius is the curvature of the surface in question at the surface vertex and h is the distance of a point thereon from the optical axis. The sagitta or rising height p(h) thus represents the distance of that point

from the vertex of the surface in question, measured along the z-direction, i.e., along the optical axis. The constants K, C1, C2, etc., are listed in Table 2A.

[0076] It is remarkable that in this embodiment many aberrations are corrected to a high degree with a small number of lenses ($N_L=13$) and only one aspheric lens (L3-4) in addition to the aspheric concave mirrors CM1, CM2. Particularly, all third-order and fifth-order aberrations are zero. The variation in telecentricity is corrected over the field. Higher-order (seventh-order and higher) distortion is corrected over the field. Pupil aberration on the image side is corrected so that the image side numerical aperture NA=1.2 is constant over the field. Two real rays are corrected on-axis and four aperture rays are corrected at an intermediate field point. Higher-order (seventh-order and higher) astigmatism is corrected at the edge of the field and at an intermediate field point. This correction status is obtained with an objective where the lens diameters of the third objective part (acting as a focusing lens group) are quite small, with 218 mm diameter for the largest lens. The first lens L3-1 of the third objective part has a relatively large geometrical distance to the vertex of the geometrically nearest mirror (first concave mirror CM1), where that axial mirror-lens-distance MLD is 90 mm. This is about 7.5% of the axial distance between object surface OS and image surface IS, this object-image distance also being denoted as “track length”. A large geometrical distance MLD between the image side first concave mirror CM1 and the first lens of the third objective part contributes to small lens diameters in the third objective part.

[0077] The last lens L3-9 on the image side (immersion lens) has a short radius (50 mm) of the spherical entrance surface, whereby small incidence angles are obtained at that surface.

[0078] The design can be optimized with regard to residual aberrations, where higher order Petzval curvature and higher order sagitta oblique spherical aberration appears to dominate. Adding one lens to the first objective part and/or providing one or more further aspheric surfaces can contribute to reduce the residual aberrations. An example of a further development of the design of FIG. 2 is shown in FIG. 3, where an additional negative lens L1-4 designed as a meniscus lens having an image side concave surface is added in the first objective part between the pupil surface P1 thereof and the first intermediate image. This modification allows to correct the mentioned residual aberrations. This example exemplifies, amongst others, that the basic design allows high flexibility for correcting imaging errors within overall simple construction with small number of lenses and a small number of aspherical lenses.

[0079] A fourth embodiment of a projection objective **400** is shown in FIG. 4, the specification thereof is given in tables 4 and 4A. Similar to the embodiments of FIGS. 2 and 3, there is only one aspheric lens, namely positive meniscus lens L3-4 having an aspheric exit surface, in that system, placed in the third objective part OP3 in the region of largest beam diameter upstream of the aperture stop AS optically close to the pupil surface P3 of that objective part. The first objective part OP1 is all-spherical, having only one negative lens L1-4 in a sequence P-P-P-N-P, where “P” denotes a positive lens and “N” denotes a negative lens. From a construction point of view, a large axial distance between the vertex of the image side concave mirror CM1 and the first lens L3-1 of the third objective part OP3 is apparent, this distance MLD being more than 10% of the track length.

[0080] FIG. 5 shows a variant of the systems of FIGS. 3 and 4, where slight modifications predominantly in the first objective part OP1 were applied to improve correction. The resulting design of FIG. 5 has two field points that are corrected for both astigmatism and Petzval curvature, and the field zone with no astigmatism is in focus.

[0081] In preferred designs of the invention, distortion, astigmatism, Petzval curvature and telecentricity variation over the field can all be corrected to very high orders with a similar construction of the first objective part OP1 (serving as a relay system to form the first intermediate image IMI1) and only a few spherical lenses in addition to the aspheric mirrors.

[0082] It appears that two aspheric concave mirrors CM1, CM2 are important for obtaining good correction with a small number of aspheric lenses. Two aspheric mirrors generally allow to make a design that is corrected for two chief ray aberrations, like distortion and telecentricity variation, to very high orders. It appears that those two aberrations can be exactly corrected by the two aspheric mirrors if the aspheric deformations of that mirrors are set correctly. It is one remarkable aspect, that, in addition, the astigmatism and Petzval curvature can also be corrected to a high degree with an all-spherical first objective part OP1.

[0083] It appears that there are at least three characteristics, which, singly or in combination, can contribute to the positive properties of the design type with regard to aberration corrections. One aspect is that the concave mirrors may preferably be quite unequal in radius, compared to other embodiments where the concave mirrors CM1, CM2 are identical or almost identical. Further, it appears that quite a lot of coma at the intermediate images IMI1 and/or IMI2 facilitates correction with a small number of aspheric lenses. Also, the remarkably large air space (mirror-lens-distance MLD) between the vertex of the image side concave mirror CM1 and the first lens of the third objective part appears to contribute to that beneficial properties.

[0084] It appears that the object side and the image side and/or the projection objective, i.e. the first objective part OP1 and the third objective part OP3, can almost be designed independently. In particular, the third objective part (focusing lens group) can be designed for aperture aberrations without much concern for field aberrations, and then a first objective part being relatively simple in construction can be designed to compensate for field aberration, wherein that compensation might be obtained without aspheric lenses or with only a small number of aspheric lens, e.g. only one aspheric lens.

[0085] The previous embodiments show that designs are available having a fairly simple first objective part with only four or five lenses, where all lenses may be spherical. Such rather simple relay lens group can give correction for field aberrations to an extremely high order. Aperture aberrations are preferably corrected in the third objective part, which may also have a fairly simple construction with just a few aspherics, the number of aspheric lenses in third objective part preferably being higher than the number of aspheric lenses in the first objective part.

[0086] FIGS. 6 and 7 show closely related embodiments 600, 700, where the number of aspheric lenses in the refractive first and third objective part is increased when compared to the previous embodiments. The specification of objective 700 is given in tables 7 and 7A. An improvement with respect to aperture aberrations is obtained. Particularly, seven aspheric lenses are used, where $N_{1,AS}=2$ and $N_{3,AS}=5$, such that the aspheric lens ratio $ASR=0.4$. The design of FIG. 6

having two aspheric lenses L1-2 and L1-5 in the first objective part OP1 has an wavefront aberration of 5 milliwaves over the field.

[0087] One double asphere DA is provided in the third objective part OP3 optically between a second intermediate image IMI2 and the pupil surface P3 of that objective part in a region of significantly increasing beam diameter. The double asphere is formed by the aspheric exit surface of positive lens L3-6 and the subsequent aspheric entry surface of the following positive meniscus lens L3-7 immediately adjacent thereto. The axial separation of the two aspheric surfaces is smaller than the thickness of the thinner lens L3-7 adjacent to the double asphere such that the aspheres are in close proximity. A complex radial distribution of refractive power is thereby obtained in a specific region of the beam, thereby contributing strongly to image correction.

[0088] FIGS. 8 and 9 show embodiments 800, 900 very similar in design. The specification of projection objective 900 is given in tables 9, 9A. An image-side numerical aperture $NA=1.2$ and wavefront error of about 6 milliwaves is obtained with only six aspheric lenses, where one aspheric lens (positive meniscus L1-5 having image side concave surface placed near the pupil surface P1) is provided in the first objective part and the remainder of five aspheric lenses are distributed within the third objective part OP3. These aspheric lenses include a biconcave negative meniscus L3-2, a double asphere DA formed by a lens pair L3-5, L3-6 with facing aspheric surfaces, a biconvex positive lens L3-9 close to the aperture stop AS, and a positive lens L3-10 between the aperture stop and the image surface IS. As indicated by the ray distribution in FIG. 8, the front pupil in the relay section formed by first objective part OP1 is pretty well corrected. A focus region with little or no coma aberrations (low-coma intermediate image) for both intermediate images IMI1 and IMI2 is apparent. The low-coma intermediate image IMI2 is refocused onto the image surface with refractive objective part OP3 having a thick positive lens L3-1 on the entry side and a significant waist W (i.e. a region of beam diameter constriction) between the first lens L3-1 and the region of largest beam diameter shortly upstream of the aperture stop AS. Double asphere DA is placed in the divergent beam between the waist and the aperture stop AS.

[0089] The projection objective 1000 in FIG. 10 may in some respects be considered as a variant of the embodiments shown in FIGS. 8 and 9. A specification thereof is given in tables 10, 10A. Whereas the third objective part OP3 has five aspheric lenses relatively similar in design and positioning when compared to the embodiments 800 and 900, there is no aspheric lens in the first objective part OP1, such that $N_{AS}=5$. Remarkably, an all-spherical doublet consisting of an image-side biconvex positive lens L1-6 and a negative meniscus lens L1-7 having an object side concave surface immediately downstream of the positive lens is positioned near the pupil surface P1. High angles of incidence of rays exiting the positive lens L1-6 and entering the subsequent negative lens L1-7 are found in that region, where the angles of incidence include angles larger than 60° . It appears that the optical effect of the aspheric lens L1-5 of embodiments 800, 900 having a difficult to manufacture aspheric surface with rapid slope changes can at least partly be simulated by using some fairly high incidence angles (in the range of 60° - 65°) in a similar region near the pupil surface of the first objective part OP1. Since the spherical surfaces of the doublet lenses L1-6, L1-7 are easier to manufacture, manufacturability can be improved in some

cases by replacing an aspheric lens by one or more spherical lens surfaces where high incidence angles occur.

[0090] When replacement of an aspheric surface by spherical surfaces is considered, it appears that what most matters is the base spherical curvature. A spherical doublet may therefore be able to replace an aspheric surface—even a very high order aspheric.

[0091] The correction status of variants of embodiment **1000** ranges between 4, 5 and 6 milliwaves over the field. This indicates that this correction can be obtained with an all-spherical first objective part OP1 and that the complete design does not need many aspheric lenses (only 5 lens aspherics here) to obtain a good performance.

[0092] The specification of the catadioptric projection objective **1100** is given in tables 11, 11A. The embodiment is a good example to show that “double aspheres” having two pretty strong aspheric lens surfaces very close to each other may be a very powerful design component. Here, a double asphere DA formed by lenses L3-4 and L3-5 is found in the region of increasing beam diameter within the third objective part OP3, similar to the embodiments shown in FIGS. 8, 9, and 10, for example. In addition, a second double asphere DA formed by the facing surfaces of lenses L1-5 and L1-6 is present optically near the front pupil, i.e. the pupil surface P1 of the first objective part OP1. In this embodiment, $N_{AS}=8$, $N1_{AS}=3$ and $N3_{AS}=5$. The correction is about 2.5 milliwaves only at NA=1.2, with the largest lens diameter of 220 mm found in the third objective part close to the aperture stop AS. This exemplifies the potential of this design for obtaining good optical performance with a small number of aspheric lenses.

[0093] FIG. 12 shows an immersion objective for $\lambda=193$ nm having NA=1.3 (instead of NA=1.2 in the previous examples). The largest lens diameter (found shortly upstream of the aperture stop AS within the third objective part OP3) is 270 mm. There are just eight aspheric lenses with $N1_{AS}=2$ and $N3_{AS}=6$. These include one double asphere DA formed by lenses L3-4 and L3-5 and positioned in a region of diverging beam between a waist W in the third objective part and the aperture stop AS. The field radius is 66 mm. The correction is about 4 to 6 milliwaves over the field. The design assumes exactly telecentric input. It is evident that from the ray configuration at the intermediate images that there is a large amount of coma at the intermediate images.

[0094] A further embodiment of a catadioptric immersion objective **1300** with NA=1.3 is shown in FIG. 13. The specification is given in tables 13, 13A. $N_{AS}=10$, $N1_{AS}=4$ and $N3_{AS}=6$. Although the image-side numerical aperture NA=1.3 corresponds to that of objective **1200**, the largest lens diameter is only 250 mm (instead of 270 mm in embodiment **1200**). Still, the wavefront error is about 4 milliwaves over the field only. Again, the design is characterized by the absence of a real stop so that a telecentric input is required. Again a large amount of coma is found at the intermediate images.

[0095] The catadioptric immersion objective **1400** in FIG. 14 (specification given in tables 14 and 14A) is another example of a high NA catadioptric immersion objective with NA=1.3 and a relatively small maximum lens diameter, that lens diameter of the largest lens being only 250 mm. Four out of eleven aspheric lenses are found in the first objective part OP1, the remainder of seven aspheric lenses is distributed in the third objective part OP3. When compared to previous designs, manufacturability of the aspheric lenses is improved by observing the requirement that all of the aspheric lens

surfaces have less than 1.0 mm deformation from a spheric surface and have local aspheric radii being greater than 150 mm for each aspheric surface. Three double aspheres are provided. One double asphere DA formed by lenses L1-6 and L1-7 positioned at the pupil surface P1 within the first objective part OP1 is designed to have fairly high incidence angles which appears to have a similar effect as short local aspheric radii (which are more difficult to manufacture).

[0096] There are two double aspheres DA in the third objective part OP3, namely one double asphere formed by facing surfaces of negative lenses L3-1, L3-2 in the region of minimum lens diameter within the third objective part, and a subsequent double aspheric formed by facing surfaces of lenses L3-3 and L3-4 in the region of largest beam diameter increase between the second intermediate image IMI2 and the aperture stop AS, which is positioned between the region of largest beam diameter and the image surface IS. Like the embodiments of FIGS. 11 to 13, large amount of coma is present in the intermediate images IMI1, IMI2.

[0097] The catadioptric immersion objective **1500** in FIG. 15 (specification in tables 15 and 15A) is a variant of the embodiment shown in FIG. 14, where sizes and types of lenses present in the objective **1500** are essentially the same. A difference lies in the fact that an additional biconvex positive lens L3-1 is introduced immediately after the second intermediate image IMI2, thereby providing positive refractive power on the entry side of third objective part OP3. Good performance at NA=1.3 is obtained.

[0098] The basic design has potential for even higher image side numerical apertures with NA>1.3. The catadioptric immersion objective **1600** in FIG. 16 (specification in tables 16 and 16A) is based on the design of FIG. 15, but optimized to obtain NA=1.35. Like in that embodiment, there are ten lenses in the first objective part (including 4 aspheric lenses), and twelve lenses in the third objective part (including 7 aspheric lenses). Although the basic types of lenses are the same, lens thickness, surface radii and lens positions differ slightly. As the numerical aperture increases, it appears beneficial to place the aperture stop AS in the third objective part OP3 between the region of maximum beam diameter (at biconvex lens L3-8) and the image surface IS in the region of strongly converging beam. Here, only three positive lenses are placed between the aperture stop and the image surface.

[0099] It may be beneficial to place the second objective part OP2 geometrically closer to the image surface the higher the desired numerical aperture is. For convenience, the second objective part OP2, preferably consisting of two aspheric concave mirrors CM1, CM2 only, is also denoted “mirror group” in the following. In order to demonstrate this feature, a first optical axis length OAL1 is defined between the object surface OS and the vertex of the concave mirror CM2 geometrically closest to the object surface, and a third optical axis length OAL3 is defined between the vertex of the concave mirror (CM1) geometrically closest to the image surface and the image surface (see FIG. 16). Based on this definition, a mirror group position parameter $MG=OAL1/OAL3$ is defined, where this value tends to be larger the further the mirror group tends to be positioned on the image side of the projection objective. In table 17, the values of OAL1, OAL3 and MG are summarized for all embodiments described here. Based on these data, a mirror group position parameter $MG>0.7$ appears to be desirable in order to obtain high image side numerical apertures. Preferably, $MG\geq 0.8$. More preferably, $MG\geq 0.9$.

[0100] Each projection objective described here has a high NA image side end where projection radiation exits the projection objective at an exit surface ES, which is preferably planar in order to allow a uniform distance between the exit surface and a planar substrate surface arranged at the image surface IS. The lens closest to the image surface and forming the exit surface ES, is denoted "last lens" LL here. Preferably, the last lens is a plano-convex positive lens having a curved entry surface ENS, which is spherically curved in most embodiments, and the planar exit surface ES. In order to obtain high NA it has been found useful to design the last lens such that large refractive power provided by the curved entry surface ENS is arranged as close as possible to the image surface.

[0101] Further, strong curvatures, i.e. small curvature radii of the entry surface ENS of the last lens LL appear desirable. If T_{LL} is the thickness of the last lens on the optical axis (i.e. the axial distance between the entry surface ENS and the exit surface ES measured along the optical axis), R_{LL} is the object side vertex radius of the last lens (i.e. the radius of the entry surface ENS), and DIA_{LL} is the optically free diameter of the entry surface of the last lens, then the parameters $LL1=T_{LL}/R_{LL}$ and $LL2=DIA_{LL}/R_{LL}$ should preferably fall within certain limits. Particularly, it has been found useful if the conditions $1.1 < LL1 < 2.2$ holds for LL1. Preferably, the upper limit may be even smaller, such as 1.8 or 1.7 or 1.6. As parameter LL1 becomes unity for a hemispherical lens, where the center of curvature of the entry surface coincides with the exit surface, the condition regarding LL1 shows that non-hemispherical last lenses are preferred, where the center of curvature of the curved entry surface lies outside the last lens, particularly beyond the image surface.

[0102] Alternatively, or in addition, the condition $2.1 < LL2 < 2.6$ should preferably hold for LL2. The upper limit could be smaller, e.g. 2.5 or 2.4 or 2.3. The respective values for LL1 and LL2 are presented in table 18. If at least one of the above condition holds, strong positive power provided by the curved entry surface of the last lens is provided close to the image surface, thereby allowing a large image side numerical aperture NA to be obtained, particularly with $NA > 1.1$ or $NA > 1.2$, such as $NA = 1.3$ or $NA = 1.35$.

[0103] With regard to the correction status of the intermediate images IMI1, IMI2 it is found that in some embodiments both intermediate images are essentially focused (i.e. many aberrations are corrected to a high degree), whereas in other embodiments significant aberrations occur, particularly coma (compare FIG. 11-16) A significant coma aberration for the second intermediate image IMI2 may be beneficial with respect to overall correction of the objective. Since the catoptric second objective part consisting of the concave mirrors CM1 and CM2 is effective to image the first intermediate image into the second intermediate image in an essentially symmetric manner, only little coma is usually introduced by the catoptric second objective part. Therefore, the correction status with respect to coma for both intermediate images tends to be similar. For some embodiments, a significant amount of coma at least for the second intermediate image appears to contribute significantly to the overall correction. The following observations are notable in that respect.

[0104] The correction of the sine condition of the entire objective is challenging particularly for objectives having very high image side NA. The correction of sine condition may be facilitated by coma in the intermediate image. If the imaging from the high NA image surface to the low NA object

surface (i.e. in reverse direction when compared to the intended use of projection objectives in lithography) is considered, the third objective part (where radiation enters) provides an intermediate image having a certain correction status. Assuming that the spherical aberration of that imaging is corrected, then the intermediate image will be essentially free of coma, if the sine condition of that imaging would be corrected. In contrast, if the sine condition is not corrected, that intermediate image would have a significant amount of coma. If the intermediate image has a considerable amount of coma, correction of the sine condition in the third objective part is facilitated.

[0105] Now, imaging of the second intermediate image into the image surface in the intended direction (towards the high NA end) is considered. If the second intermediate image would have a good correction status, particularly without coma, then the entire correction of the sine condition would have to be effected by the third objective part imaging the second intermediate image onto the image surface. If, in contrast, a certain amount of coma is present in the second intermediate image, then the third objective part can be designed in a more relaxed manner since the correction of the sine condition can at least partly be effected by the objective parts optically upstream of the third objective part, i.e. the refractive relay system OP1 forming the first intermediate image, and the catoptric second objective part OP2. Therefore, it appears that designs where the correction of coma is distributed between the first refractive objective part OP1 and the third objective part OP3 may be beneficial when compared to objectives where each of that refractive objective part is independently corrected for coma.

[0106] As mentioned earlier, the invention allows to build high NA projection objectives suitable for immersion lithography at $NA > 1$ with compact size.

[0107] Table 19 summarizes the values necessary to calculate the compactness parameters COMP1, COMP2, COMP3 and the respective values for these parameters for each of the systems presented with a specification table (the table number (corresponding to the same number of a figure) is given in column 1 of table 19). Further, the respective values for $N1_{AS}$, $N3_{AS}$, and ASR are shown.

[0108] Table 19 shows that preferred embodiments according to the invention generally observe at least one of the conditions given earlier indicating that compact designs with moderate material consumption are obtained according to the design rules laid out in this specification. Further, the particular values characterizing the aspheric lens number and distribution are shown.

[0109] In the following, further characteristic features of projection objectives according to the invention are summarized, where one or more of those features may be present in an embodiment of the invention. Parameters summarized in tables 20 and 21 are used to demonstrate these features.

[0110] In some embodiments, the chief ray of the imaging process takes a characteristic course. For demonstration purposes, a chief ray CR running from an outermost field point (furthest away from the optical axis AX) essentially parallel to the optical axis and intersecting the optical axis at three consecutive pupil surface positions P1, P2, P3, each within one of the imaging objective parts OP1, OP2, OP3, is drawn in bold line in FIG. 16 to facilitate understanding. The angle included between the optical axis AX and the chief ray CR at each position along the chief ray is denoted "chief ray angle" CRA in the following. The chief ray CR is divergent (chief ray

height increasing in light propagation direction) at the position of the first intermediate image IMI1 and converging at the position of the second intermediate image IMI2. Strongly converging chief rays appear to be beneficial to obtain high image side NA and a sufficient correction.

[0111] In the region between the two concave mirrors CM1, CM2, the chief ray crosses the optical axis at a high chief ray angle CRA (M), that angle preferably falling in the region between 58° and 75°, particularly between 60° and 72°. (see table 20).

[0112] With regard to the magnification provided by the imaging objective parts OP1, OP2, OP3 it appears that it is beneficial if the magnification β_3 of the third objective part OP3 imaging the second intermediate image IMI2 at high reduction ratio onto the image surface should preferably fall within a range $0.11 \leq \beta_3 \leq 0.17$. In order to obtain a desired overall reduction ratio (e.g. 1:4 or 1:5) the second objective part OP2 may contribute to the overall reduction by having a magnification ratio $\beta_2 < 1$. Preferably, the mirror group forming the second objective part OP2 may be designed to have a moderate reducing effect characterized by $0.85 \leq \beta_2 < 1$. If the second objective part contributes to some extent to the overall reduction, the third objective part responsible for the major part of reduction can be designed in a more relaxed manner.

[0113] It appears that the refractive power (characterized by the focal length f) provided by the first two or three lenses on the entry side of the third objective part OP3 immediately after the second concave mirror CM2 may contribute to good performance by designing this entry group such that the overall refractive power of that entry group is negative. In the embodiments of FIGS. 2, 4, 14, 15, 16, the entry group is formed by the first two lenses of the third objective part, providing an entry group focal length f3 (L1 . . . 2). In the embodiments of FIGS. 7, 9, 10, 11, 12, 13, the entry group is formed by three consecutive lenses, thereby providing a focal length f3 (L1 . . . 3) of the entry group. Values are given in table 20.

[0114] On the other hand, it appears that not many negative lenses should be present in the third objective part following the second concave mirror CM2, where that number N_{3NL} of negative lenses is three or less than three in all embodiments (parameter K7a=YES in table 21), and is smaller than three in the embodiments of FIGS. 2, 4, 14, 15, 16 (parameter K7=YES in table 21).

[0115] Further, it appears to be beneficial if the optically free diameter DIA_{31} of the first lens L3-1 of the third objective part OP3 is significantly smaller than the diameter DIA_{AS} of the aperture stop. Preferably, the diameter ratio $DR = DIA_{31} / DIA_{AS}$ should be smaller than 0.9. More preferably, an upper value of 0.8, even more preferably an upper value of 0.7 should not be exceeded. Values for the diameter ratio DR are given in table 21.

[0116] Further, it has been found that it may be beneficial if more than 50% of all lenses after the second concave mirror (i.e. lenses of the third objective part) have an optically free diameter smaller than the diameter of the second intermediate image IMI2 following the second concave mirror CM2. This condition is fulfilled for all embodiments, as shown by parameter K10 in table 21.

[0117] Also, all lenses of the first, refractive objective part OP1 should preferably be smaller than the paraxial size of the first intermediate image. If this condition is fulfilled, parameter K9 in table 20 is fulfilled.

[0118] In order to provide strong positive refractive power for obtaining strong beam convergence at the high NA image end it is preferable if at least one of 8 and 9 consecutive lenses upstream of the image surface should have positive refractive power. This is exemplified by parameter K11 in table 21, which is “YES”=Y if the condition is fulfilled and “NO”=N if the condition is not fulfilled.

[0119] In this context it is worth to note that it appears beneficial for obtaining high NA, if the position of the aperture stop AS is in the region of convergent beam between the position of largest beam diameter within the third objective part OP3, and the image surface. This property is exemplified by the ratio AS-IS/TT shown in table 20, where AS-IS is the geometrical distance between the position of the aperture stop AS and the image surface IS, and TT is the “track length” of the objective, i.e. the geometrical distance between object surface and image surface. The ratio AS-IS/TT may fall in a range between 0.09 and 0.18 (see table 20).

[0120] This feature is particularly pronounced in embodiments of FIGS. 12 to 16.

[0121] Further characteristic features are evident from the course of the coma beam. Here, a “coma beam” refers to a beam emerging from an object field point furthest remote from the optical axis and transiting the aperture stop at the edge of the aperture. The coma beam therefore contributes to determining which lens diameters must be used. The angle included by this coma beam and the optical axis is denoted in “coma beam angle CBA” in the following. The angle of that beam after refraction at the last lens of the first objective part (upstream of the first intermediate image IMI1) is denoted CBA1, whereas the angle of the coma beam immediately upstream of the refraction at the first lens of the image side third objective part OP3 is denoted CBA3. The values of these angles are given in table 21. It appears that for both coma beam angles values of less than 5° may be beneficial (table 21).

[0122] As noted above, the chief ray intersects the optical axis at pupil surfaces P1, P2, P3 in the concatenated objective parts OP1, OP2, OP3. As the pupil surfaces within the first and third objective parts are accessible for setting an aperture stop, these positions are also denoted aperture positions. The beam diameter at the aperture stop, DIA_{AS} and the beam diameter DIA_{P1} at the pupil surface P1 in the first objective part, conjugated to the position of the aperture stop, should fall within certain limits. The ratio DIA_{AS} / DIA_{P1} should be larger than 1. Preferably the condition $DIA_{AS} / DIA_{P1} > 2$ should be satisfied. (see table 21).

[0123] It is to be understood that all systems described above may be complete systems for forming a real image (e.g. on a wafer) from a real object. However, the systems may be used as partial systems of larger systems. For example, the “object” for a system mentioned above may be an image formed by an imaging system (relay system) upstream of the object plane. Likewise, the image formed by a system mentioned above may be used as the object for a system (relay system) downstream of the image plane.

[0124] The above description of the preferred embodiments has been given by way of example. From the disclosure given, those skilled in the art will not only understand the present invention and its attendant advantages, but will also find apparent various changes and modifications to the structures and methods disclosed. It is sought, therefore, to cover all changes and modifications as fall within the spirit and scope of the invention, as defined by the appended claims, and equivalents thereof.

[0125] The contents of all the claims is made part of this description by reference.

TABLE 2

SURF	RADIUS	THICKNESS	MATERIAL	INDEX	SEMIDIAM.
0	0	35.375532			66
1	131.949135	35.970704	SILUV	1.56038308	87.585
2	406.761557	104.80906			85.863
3	3059.843345	27.506721	SILUV	1.56038308	75.651
4	-198.500428	1.017885			74.735
5	130.040913	27.00543	SIO2V	1.5607857	63.806
6	645.092151	131.039998			59.727
7	295.611694	27.141936	SIO2V	1.5607857	73.901
8	-488.184201	269.934616			75.186
9	-168.378905	-229.757172	REFL		146.55
10	191.880744	321.03168	REFL		142.027
11	3866.479073	15	SILUV	1.56038308	84.264
12	200.296391	23.187613			81.401
13	-853.282183	12	SILUV	1.56038308	81.615
14	183.221555	40.757592			85.452
15	-260.121033	40.375633	SILUV	1.56038308	88.116
16	-119.830244	1.000373			93.697
17	377.105699	25.88629	SILUV	1.56038308	107.44
18	806.870168	6.60952			108.283
19	402.481304	53.968509	SILUV	1.56038308	109.043
20	-239.942098	30.458674			110.617
21	0	0			105.938
22	448.147113	83.062268	SILUV	1.56038308	104.924
23	-279.740357	1			97.993
24	225.5812	54.802627	SILUV	1.56038308	86.607
25	-998.977091	1			76.79
26	66.501558	33.495315	SILUV	1.56038308	57.153
27	131.610919	0.100001			48.532
28	49.614771	31.476238	SILUV	1.56038308	37.98
29	0	3	H2OV193	1.43667693	21.144
30	0	0			16.918

TABLE 2A

Aspheric constants			
SRF			
	9	10	18
K	-0.452326	-0.261902	0
C1	0.00E+00	0.00E+00	9.85E-08
C2	7.69E-14	-1.44E-15	6.78E-13
C3	-1.99E-18	2.07E-19	-8.47E-17

TABLE 2A-continued

Aspheric constants			
SRF			
	9	10	18
C4	4.90E-22	-1.14E-23	-2.33E-21
C5	-2.26E-26	-5.61E-28	-3.90E-27
C6	5.71E-31	4.00E-32	0.00E+00

TABLE 4

SURF	RADIUS	THICKNESS	MATERIAL	INDEX	SEMIDIAM.
0	0	35.793949			66
1	120.118526	42.934369	SIO2V	1.5607857	90.022
2	412.405523	126.645729			87.381
3	633.242338	22.659816	SIO2V	1.5607857	61.491
4	-210.086581	46.042292			60.076
5	130.137899	30.712802	SIO2V	1.5607857	61.678
6	-522.603119	34.752273			61.093
7	-1187.517919	12	SIO2V	1.5607857	59.563
8	114.106019	28.350504			59.307
9	222.108344	30.902208	SIO2V	1.5607857	68.301
10	-299.15163	256.466683			69.608
11	-150.205889	-216.466684	REFL		144.702
12	198.80711	372.659505	REFL		143.838
13	281.738211	19.28133	SIO2V	1.5607857	93.203
14	125.854932	30.787413			85.622
15	774.983336	12	SIO2V	1.5607857	86.014

TABLE 4-continued

SURF	RADIUS	THICKNESS	MATERIAL	INDEX	SEMI DIAM.
16	190.931672	31.687547			88.47
17	-741.767142	42.517621	SIO2V	1.5607857	90.935
18	-141.29554	16.921402			95.293
19	161.709504	50.734927	SIO2V	1.5607857	110.341
20	256.329089	15.962417			100.811
21	231.628153	52.349429	SIO2V	1.5607857	101.677
22	-355.162157	24.394096			100.975
23	0	0			90.786
24	298.995001	34.357885	SIO2V	1.5607857	87.38
25	-413.984465	1			84.467
26	175.550604	30.458976	SIO2V	1.5607857	75.285
27	577.927994	1			68.756
28	62.317914	30.663962	SIO2V	1.5607857	53.826
29	131.702852	0.1			46.784
30	50	29.329548	SIO2V	1.5607857	36.877
31	0	3	H2OV193	1.43667693	21.061
32	0	0			17.019

TABLE 4A

Aspheric constants			
SRF			
	11	12	20
K	-0.536388	-0.289717	0
C1	0.00E+00	0.00E+00	1.38E-07
C2	1.40E-13	1.67E-15	1.67E-12
C3	-1.27E-17	7.77E-21	-1.05E-16

TABLE 4A-continued

Aspheric constants			
SRF			
	11	12	20
C4	1.60E-21	1.74E-23	6.80E-21
C5	-8.54E-26	-1.14E-27	-2.06E-24
C6	2.08E-30	3.15E-32	1.25E-28

TABLE 7

SURF	RADIUS	THICKNESS	MATERIAL	INDEX	SEMI DIAM.
0	0	35.099987	LUFTV193	1.00030168	66
1	127.537708	53.812686	SIO2V	1.5607857	88.311
2	-1424.403792	3.183483			85.654
3	-759.069196	12	SIO2V	1.5607857	85.361
4	433.221851	0.999992	N2VP950	1.00029966	81.029
5	138.239142	29.708609	SIO2V	1.5607857	81.573
6	417.683183	28.068546	N2VP950	1.00029966	79.153
7	178.55362	36.417688	SIO2V	1.5607857	70.512
8	-494.07005	2.060781	N2VP950	1.00029966	65.044
9	155.188372	24.032084	SIO2V	1.5607857	54.381
10	599.310224	35.766015	N2VP950	1.00029966	44.737
11	-222.232519	15.518078	SIO2V	1.5607857	43.157
12	-158.540648	83.688942	N2VP950	1.00029966	48.398
13	-340.58772	31.059836	SIO2V	1.5607857	87.94
14	-151.34275	0.999997	N2VP950	1.00029966	92.472
15	-3390.668582	33.959537	SIO2V	1.5607857	99.743
16	-231.522766	249.6227	N2VP950	1.00029966	101.635
17	-184.547095	-209.6227	REFL	1.00029966	139.73
18	167.029818	249.92793	REFL	1.00029966	120.262
19	621.261771	25.224239	SIO2V	1.5607857	88.34
20	-556.892379	11.423072	N2VP950	1.00029966	87.849
21	928.352541	31.861443	SIO2V	1.5607857	84.353
22	-3894.042096	4.258076	N2VP950	1.00029966	81.388
23	-515.240387	10.001518	SIO2V	1.5607857	80.081
24	128.35306	19.188164	N2VP950	1.00029966	74.104
25	308.870114	10.000043	SIO2V	1.5607857	74.899
26	137.165863	21.160324	N2VP950	1.00029966	75.171
27	535.690303	10.000083	SIO2V	1.5607857	77.414
28	270.832047	16.021774	N2VP950	1.00029966	81.505
29	6886.310806	36.167214	SIO2V	1.5607857	84.419
30	-205.759199	3.943304	N2VP950	1.00029966	92.09
31	-673.879021	20.931667	SIO2V	1.5607857	96.507
32	-289.392079	17.53001	N2VP950	1.00029966	102.53

TABLE 7-continued

SURF	RADIUS	THICKNESS	MATERIAL	INDEX	SEMIDIAM.
33	-578.552137	45.351534	SIO2V	1.5607857	114.339
34	-180.862466	0.999999	N2VP950	1.00029966	118.861
35	486.683329	67.153511	SIO2V	1.5607857	127.052
36	-560.582675	-0.510173	N2VP950	1.00029966	126.509
37	0	8.553303	N2VP950	1.00029966	124.301
38	804.757635	41.461871	SIO2V	1.5607857	124.183
39	-290.647705	1.000095	N2VP950	1.00029966	124.308
40	251.571322	46.634322	SIO2V	1.5607857	109.472
41	-989.86448	1.000042	N2VP950	1.00029966	103.95
42	86.546078	40.283002	SIO2V	1.5607857	72.678
43	219.985874	0.999974	N2VP950	1.00029966	63.421
44	87.427095	40.057397	SIO2V	1.5607857	50.39
45	0	3	H2OV193	1.43667693	21.125
46	0	0			16.5

TABLE 7A

Aspheric constants									
SRF									
	4	10	17	18	22	30	31	38	41
K	0	0	-0.746204	-0.286924	0	0	0	0	0
C1	6.03E-08	4.24E-07	0.00E+00	0.00E+00	-1.62E-07	5.31E-08	-5.32E-08	-3.90E-08	-2.16E-08
C2	7.60E-12	-3.19E-11	3.46E-14	6.73E-15	5.78E-12	1.81E-12	-1.14E-13	4.45E-15	2.47E-12
C3	-2.87E-17	1.88E-14	-2.87E-19	-1.19E-18	2.80E-16	1.20E-16	8.83E-17	4.67E-17	-8.51E-17
C4	-1.68E-21	-2.25E-18	1.04E-22	2.14E-22	2.70E-22	-4.21E-21	-8.32E-21	-1.21E-21	3.85E-21
C5	1.40E-24	1.47E-21	-7.95E-27	-2.28E-26	-1.87E-24	-3.09E-25	3.44E-25	3.05E-27	-1.62E-25
C6	2.15E-30	4.27E-25	3.94E-31	1.46E-30	1.45E-28	-6.36E-31	-3.35E-29	9.87E-32	5.85E-30
C7	-1.03E-32	-5.55E-28	-1.07E-35	-5.11E-35	-5.39E-33	-1.97E-33	1.94E-33	3.24E-38	-6.78E-35
C8	1.22E-36	1.42E-31	1.22E-40	7.66E-40	1.42E-36	-7.59E-38	-2.07E-37	7.29E-42	-7.43E-40

TABLE 9

SURF	RADIUS	THICKNESS	MATERIAL	INDEX	SEMIDIAM.
0	0	35	LUFTV193	1.00030168	66
1	167.582589	42.122596	SIO2V	1.5607857	84.14
2	-417.631156	7.351797			83.778
3	-242.658436	14.999993	SIO2V	1.5607857	83.61
4	-639.381532	1	N2VP950	1.00029966	84.261
5	118.161915	52.272937	SIO2V	1.5607857	82.935
6	-405.15896	2.506345	N2VP950	1.00029966	79.384
7	-349.632507	57.987649	SIO2V	1.5607857	78.093
8	-625.61536	0.999978	N2VP950	1.00029966	57.316
9	258.6518	13.775087	SIO2V	1.5607857	51.65
10	3309.642007	6.085525	N2VP950	1.00029966	46.297
11	2505.032734	45.485164	SIO2V	1.5607857	44.366
12	-160.280782	83.214895	N2VP950	1.00029966	43.224
13	-179.709766	28.095749	SIO2V	1.5607857	75.748
14	-113.094268	0.99999	N2VP950	1.00029966	80.728
15	-828.761389	28.910199	SIO2V	1.5607857	86.836
16	-193.020806	237.594315	N2VP950	1.00029966	88.806
17	-170.301754	-197.594315	REFL	1.00029966	137.191
18	164.75935	237.900412	REFL	1.00029966	114.069
19	213.979631	41.964013	SIO2V	1.5607857	95.394
20	-571.726494	30.907497	N2VP950	1.00029966	93.468
21	-607.905756	12.000001	SIO2V	1.5607857	81.046
22	213.467641	20.540794	N2VP950	1.00029966	75.725
23	118232.9153	10.073155	SIO2V	1.5607857	75.17
24	134.456642	11.393332	N2VP950	1.00029966	73.687
25	193.022977	12.19948	SIO2V	1.5607857	75.339
26	149.820622	39.058556	N2VP950	1.00029966	76.132
27	-473.179277	16.280318	SIO2V	1.5607857	82.022
28	-265.194438	3.071697	N2VP950	1.00029966	88.666
29	-596.281929	34.549024	SIO2V	1.5607857	89.977
30	-234.857742	2.605623	N2VP950	1.00029966	100.123
31	-681.432168	46.50367	SIO2V	1.5607857	108.764

TABLE 9-continued

SURF	RADIUS	THICKNESS	MATERIAL	INDEX	SEMIDIAM.
32	-170.41214	29.245335	N2VP950	1.00029966	113.403
33	709.34663	59.972517	SIO2V	1.5607857	125.713
34	-519.598522	1.519132	N2VP950	1.00029966	126.621
35	450.108474	47.183961	SIO2V	1.5607857	123.987
36	-298.350498	-21.086597	N2VP950	1.00029966	122.98
37	0	23.537621	N2VP950	1.00029966	120.368
38	195.285408	43.215118	SIO2V	1.5607857	105.824
39	22862.90022	1.012838	N2VP950	1.00029966	100.964
40	97.777305	39.731996	SIO2V	1.5607857	76.541
41	292.58902	4.247054	N2VP950	1.00029966	67.621
42	77.06685	38.565556	SIO2V	1.5607857	47.651
43	0	3	H2OV193	1.43667693	21.068
44	0	0			16.5

TABLE 9A

Aspheric constants				
SRF	10	17	18	22
K	0	-0.609408	-0.404331	0
C1	4.50E-07	0.00E+00	0.00E+00	-6.14E-08
C2	-2.70E-11	7.78E-15	-9.34E-15	3.42E-12
C3	4.11E-14	3.36E-19	-6.87E-19	2.90E-16
C4	-1.48E-17	-2.72E-23	1.64E-25	-4.54E-21
C5	1.25E-20	2.59E-27	2.75E-27	-1.65E-24
C6	-3.96E-24	-1.24E-31	-6.03E-31	1.25E-27
C7	4.61E-28	3.13E-36	3.69E-35	-1.97E-31
C8	5.89E-32	-3.19E-41	-8.59E-40	1.57E-35

TABLE 9A-continued

Aspheric constants				
SRF	28	29	35	39
K	0	0	0	0
C1	1.09E-07	-2.77E-08	-4.34E-08	-1.96E-08
C2	3.58E-12	-7.08E-13	1.12E-13	2.57E-12
C3	5.02E-16	5.74E-16	5.13E-17	-8.29E-17
C4	-3.35E-20	-4.78E-20	-1.19E-21	5.74E-21
C5	-2.30E-24	3.19E-24	-1.83E-26	-6.59E-25
C6	5.00E-29	-2.07E-28	2.98E-31	5.81E-29
C7	-3.03E-32	6.57E-33	3.65E-35	-2.82E-33
C8	2.67E-36	-8.15E-37	-9.28E-40	5.86E-38

TABLE 10

SURF	RADIUS	THICKNESS	MATERIAL	INDEX	SEMIDIAM.
0	0	35	LUFTV193	1.00030168	66
1	287.201368	23.165416	SIO2V	1.5607857	80.746
2	9548.563984	5.351787	N2VP950	1.00029966	81.708
3	237.938727	27.034898	SIO2V	1.5607857	84.398
4	9748.474128	5.009226	N2VP950	1.00029966	83.75
5	162.029839	30.440188	SIO2V	1.5607857	81.611
6	97.700439	24.108143	N2VP950	1.00029966	71.632
7	285.67649	59.994975	SIO2V	1.5607857	72.04
8	-212.500863	1.413267	N2VP950	1.00029966	73.053
9	231.286954	59.984338	SIO2V	1.5607857	68.81
10	-272.808567	19.053716	N2VP950	1.00029966	59.332
11	470.335844	27.320605	SIO2V	1.5607857	44.739
12	-139.04097	1.780746	N2VP950	1.00029966	45.687
13	-127.442683	14.466354	SIO2V	1.5607857	45.809
14	-301.722518	29.641205	N2VP950	1.00029966	49.864
15	-87.764582	15.000004	SIO2V	1.5607857	53.623
16	-141.229355	34.507463	N2VP950	1.00029966	61.571
17	-259.685309	20.689312	SIO2V	1.5607857	75.669
18	-163.685953	1.001108	N2VP950	1.00029966	79.628
19	-425.644839	25.473178	SIO2V	1.5607857	82.933
20	-177.604049	271.436522	N2VP950	1.00029966	85.588
21	-192.411117	-231.436522	REFL	1.00029966	145.837
22	181.316474	275.635733	REFL	1.00029966	127.943
23	160.280773	39.766183	SIO2V	1.5607857	84.727
24	433.630809	1.168124	N2VP950	1.00029966	79.442
25	172.894805	12.000005	SIO2V	1.5607857	76.455
26	142.708343	25.834202	N2VP950	1.00029966	72.617
27	-522.138568	12	SIO2V	1.5607857	71.538
28	98.617841	39.707255	N2VP950	1.00029966	66.149
29	-242.043593	13.973969	SIO2V	1.5607857	67.886
30	-428.430378	1.113943	N2VP950	1.00029966	76.048
31	1395.872365	59.770439	SIO2V	1.5607857	77.227
32	-200.881136	0.999953	N2VP950	1.00029966	94.132

TABLE 10-continued

SURF	RADIUS	THICKNESS	MATERIAL	INDEX	SEMIDIAM.
33	-796.373326	36.651147	SIO2V	1.5607857	101.811
34	-231.145256	0.999958	N2VP950	1.00029966	107.115
35	1394.739591	34.401193	SIO2V	1.5607857	113.699
36	-367.962973	0.999965	N2VP950	1.00029966	114.834
37	501.517244	61.420268	SIO2V	1.5607857	114.165
38	-252.939454	-26.770128	N2VP950	1.00029966	113.428
39	0	27.770123	N2VP950	1.00029966	113.395
40	219.357199	45.58316	SIO2V	1.5607857	104.413
41	-692.879408	0.999976	N2VP950	1.00029966	100.937
42	89.810973	40.252244	SIO2V	1.5607857	73.593
43	252.083859	1.000011	N2VP950	1.00029966	64.98
44	72.146642	41.286323	SIO2V	1.5607857	48.589
45	0	3	H2OV193	1.43667693	21.154
46	0	0			16.501

TABLE 10A

Aspheric constants				
SRF	21	22	26	30
K	-0.459313	-0.341948	0	0
C1	0.00E+00	0.00E+00	-8.70E-08	1.71E-07
C2	1.02E-14	-4.95E-15	-1.61E-12	6.01E-12
C3	-5.02E-19	2.15E-19	1.90E-16	5.80E-17
C4	7.89E-23	-9.13E-23	-5.76E-20	-5.21E-20
C5	-5.82E-27	1.06E-26	1.91E-23	-8.66E-24
C6	2.63E-31	-7.20E-31	-5.62E-27	-1.36E-27
C7	-6.44E-36	2.52E-35	7.41E-31	6.08E-31
C8	6.64E-41	-3.58E-40	-4.73E-35	-5.19E-35

TABLE 10A-continued

Aspheric constants			
SRF	31	37	41
K	0	0	0
C1	-5.72E-08	-5.65E-08	-2.58E-08
C2	-2.30E-13	8.17E-14	3.95E-12
C3	1.96E-16	8.43E-17	-2.50E-16
C4	-1.01E-20	-7.58E-22	2.34E-20
C5	-1.44E-23	-6.19E-26	-2.23E-24
C6	2.35E-27	-8.89E-31	1.68E-28
C7	-1.26E-31	1.00E-34	-7.72E-33
C8	-3.01E-36	-1.44E-39	1.60E-37

TABLE 11

SURF	RADIUS	THICKNESS	MATERIAL	INDEX	SEMIDIAM.
0	0.000000	35.000000			66.0
1	213.125261	21.214076	SIO2	1.560786	82.2
2	480.525665	1.000000			82.6
3	185.297502	31.993610	SIO2	1.560786	84.8
4	7598.261113	4.999310			83.7
5	117.345388	11.527031	SIO2	1.560786	79.0
6	90.286435	62.598487			72.4
7	309.861090	34.537793	SIO2	1.560786	74.4
8	-255.169966	1.000267			73.6
9	183.493169	25.255034	SIO2	1.560786	67.0
10	-733.608935	19.932610			63.6
11	331.584148	52.054611	SIO2	1.560786	51.0
12	-141.351439	8.662425			44.3
13	-135.694467	12.000000	SIO2	1.560786	45.2
14	-438.411699	16.902875			48.6
15	-80.203122	31.804553	SIO2	1.560786	49.3
16	-123.130978	34.208750			62.6
17	-308.561940	19.408823	SIO2	1.560786	76.5
18	-190.486221	1.000288			80.0
19	-339.277899	24.240054	SIO2	1.560786	81.9
20	-169.353619	266.539075			84.6
21	-190.594737	-226.539075	REFL		149.9
22	178.620508	266.539075	REFL		125.1
23	221.347957	30.251017	SIO2	1.560786	86.1
24	1463.195317	1.000000			83.7
25	250.202612	40.863033	SIO2	1.560786	81.0
26	143.175358	28.105820			69.5
27	-407.324144	12.000273	SIO2	1.560786	68.5
28	115.532167	36.897440			67.0
29	-221.836172	11.999999	SIO2	1.560786	68.9
30	-226.960357	1.000000			74.6
31	2492.697910	55.157108	SIO2	1.560786	78.7

TABLE 11-continued

SURF	RADIUS	THICKNESS	MATERIAL	INDEX	SEMIDIAM.
32	-161.739806	1.000000			91.0
33	-695.448789	45.255799	SIO2	1.560786	97.4
34	-259.466566	1.000000			104.4
35	1602.782680	56.958100	SIO2	1.560786	107.7
36	-470.968577	1.000000			110.0
37	0.000000	0.000000			109.3
38	386.901024	44.983112	SIO2	1.560786	110.7
39	-272.274704	1.000000			111.1
40	175.872135	43.089438	SIO2	1.560786	99.5
41	-2548.763499	1.000000			95.3
42	91.643707	37.595346	SIO2	1.560786	72.4
43	255.781458	1.000000			64.0
44	67.785174	39.963844	SIO2	1.560786	47.1
45	0.000000	3.000000	H2O	1.436677	21.2
46	0.000000	0.000000			16.5

TABLE 11A

Aspheric constants					
SRF	2	10	11	21	22
K	0	0	0	-0.496553	-0.336642
C1	1.643437E-09	8.928205E-09	-8.734171E-08	0.000000E+00	0.000000E+00
C2	1.208889E-14	1.236176E-11	2.818326E-12	5.747313E-15	-6.240079E-15
C3	8.824285E-18	-1.197673E-15	-1.228572E-15	-1.412426E-19	6.784381E-20
C4	2.922597E-21	6.507491E-19	1.042260E-18	2.261574E-23	-7.158782E-23
C5	-2.369521E-25	-1.334779E-22	-3.756091E-23	-1.450149E-27	8.093083E-27
C6	3.356358E-30	2.670393E-26	-1.473570E-25	5.772350E-32	-5.720179E-31
C7	2.828477E-35	-3.381376E-30	7.050051E-29	-1.232729E-36	2.078917E-35
C8	1.430860E-38	2.797022E-34	-9.591943E-33	1.120210E-41	-3.145520E-40
SRF	26	30	31	38	41
K	0	0	0	0	0
C1	-7.826978E-08	1.171952E-07	-8.372229E-08	-4.940289E-08	-1.537092E-08
C2	1.072045E-12	5.982055E-12	1.174253E-12	4.933796E-13	3.778447E-12
C3	4.523977E-16	-1.760506E-16	-2.681026E-16	6.928288E-17	-2.017127E-16
C4	-1.271459E-19	-1.993128E-20	-1.550679E-20	-1.609487E-21	1.881073E-20
C5	3.954232E-23	-9.529811E-24	-1.593859E-24	-7.739698E-26	-2.087789E-24
C6	-1.083373E-26	1.085578E-28	-3.657276E-30	2.774226E-30	1.840295E-28
C7	1.465752E-30	2.273221E-31	2.631779E-32	-1.572253E-36	-9.812256E-33
C8	-8.520650E-35	-2.669719E-35	-7.142431E-36	-4.163468E-40	2.332003E-37

TABLE 12

SURF	RADIUS	THICKNESS	MATERIAL	INDEX	SEMIDIAM.
0	0	35			66
1	251.921115	26.62683	SILUV	1.56038308	83.147
2	-989.210896	1			83.812
3	226.732024	32.025623	SILUV	1.56038308	85.26
4	1085.208221	1			83.38
5	128.283517	22.646566	SILUV	1.56038308	80.387
6	88.961725	15.545973			70.501
7	125.835208	59.877475	SILUV	1.56038308	70.846
8	-376.328333	1			65.691
9	291.512418	41.049599	SILUV	1.56038308	60.714
10	-247.107293	6.176611			50.627
11	152.969724	21.192151	SILUV	1.56038308	42.473
12	228.518434	5.482582			43.945
13	1248.660787	43.964726	SILUV	1.56038308	44.944
14	-152.706184	12.818026			54.237
15	-87.366215	15.60332	SILUV	1.56038308	54.983
16	-85.682846	3.636916			59.545
17	-86.526213	23.242695	SILUV	1.56038308	60.097
18	-108.668356	1			69.405
19	-200	16.671044	SILUV	1.56038308	72.006
20	-142.798216	250.765038			74.782

TABLE 12-continued

SURF	RADIUS	THICKNESS	MATERIAL	INDEX	SEMIDIAM.
21	-166.718612	-210.765038	REFL		144.311
22	174.284123	264.180115	REFL		134.956
23	285.315103	27.076989	SILUV	1.56038308	95.88
24	1483.882926	52.740402			94.405
25	185.601922	11.999964	SILUV	1.56038308	84.907
26	111.087869	22.323131			81.119
27	1952.941696	12	SILUV	1.56038308	80.86
28	111.206342	58.54433			74.709
29	-126.687949	9.999452	SILUV	1.56038308	76.019
30	-155.19187	1			85.365
31	1585.242523	54.769473	SILUV	1.56038308	95.306
32	-154.387429	1			104.707
33	-348.074244	55.068746	SILUV	1.56038308	113.511
34	-243.634705	1			127.583
35	-1336.659415	41.515446	SILUV	1.56038308	135.024
36	-276.658598	1			137.317
37	435.341885	31.595504	SILUV	1.56038308	136.928
38	-3129.657481	1.00012			136.305
39	2105.975535	44.442342	SILUV	1.56038308	135.677
40	-300.54242	-13.727335			134.991
41	0	14.727335			128.371
42	267.42491	43.877196	SILUV	1.56038308	118.91
43	7074.847026	1			115.781
44	96.288803	41.059596	SILUV	1.56038308	80.776
45	228.69124	1			72.473
46	61.190052	42.233094	SILUV	1.56038308	49.33
47	0	3	WATER	1.437	23.01
48	0	0			16.502

TABLE 12A

Aspheric constants				
SRF	10	19	21	22
K	0	0	-0.418696	-0.381372
C1	3.04E-07	-2.32E-08	0.00E+00	0.00E+00
C2	4.29E-11	2.52E-13	6.76E-15	-3.96E-15
C3	-1.17E-14	-8.41E-18	7.47E-20	1.19E-19
C4	4.44E-18	-1.26E-20	-4.44E-24	-6.18E-23
C5	-1.37E-21	4.90E-25	8.79E-28	5.39E-27
C6	2.64E-25	-2.31E-28	-4.77E-32	-3.03E-31
C7	-4.76E-29	2.58E-32	1.37E-36	9.32E-36
C8	2.93E-33	-2.18E-36	-1.19E-41	-1.19E-40
SRF	26	30	31	37
K	0	0	0	0
C1	-1.87E-07	1.24E-07	-6.86E-08	-4.46E-08
C2	-1.36E-11	9.26E-12	-4.81E-14	-5.47E-13
C3	-1.96E-16	4.76E-16	7.52E-17	5.21E-17

TABLE 12A-continued

Aspheric constants				
SRF	40	43		
C4	-5.50E-21	1.38E-20	-1.74E-20	6.91E-22
C5	4.78E-24	-7.47E-24	8.52E-25	-2.40E-26
C6	-9.08E-28	5.98E-28	-2.23E-29	-2.11E-31
C7	7.93E-32	-7.73E-32	-3.06E-33	-2.39E-35
C8	-5.07E-36	7.38E-36	1.25E-37	5.01E-40
SRF	40	43		
K	0	0		
C1	-2.05E-09	-8.05E-08		
C2	1.28E-13	5.05E-12		
C3	1.78E-17	-2.49E-16		
C4	-6.14E-22	1.14E-20		
C5	4.48E-26	-3.40E-25		
C6	-1.55E-30	2.27E-30		
C7	1.88E-35	2.38E-34		
C8	-4.01E-40	-5.88E-39		

TABLE 13

SURF	RADIUS	THICKNESS	MATERIAL	INDEX	SEMIDIAM.
0	0	35			65
1	186.586828	23.414502	SIO2V	1.5607857	83.982
2	597.259215	10.26813			84.106
3	246.448938	35.48684	SIO2V	1.5607857	87.131
4	-495.470793	0.999999			86.762
5	174.29392	12	SIO2V	1.5607857	82.318
6	105.886625	42.974925			75.746
7	298.014263	30.569503	SIO2V	1.5607857	77.754
8	-362.490174	0.999996			77.303
9	197.585289	26.9647	SIO2V	1.5607857	72.92
10	115.191376	6.433657			64.383
11	87.197031	33.092701	SIO2V	1.5607857	63.668

TABLE 13-continued

SURF	RADIUS	THICKNESS	MATERIAL	INDEX	SEMIDIAM.
12	-21177.81881	11.342683			59.87
13	170.163316	22.577563	SIO2V	1.5607857	53.888
14	-397.634502	6.245625			50.153
15	-329.557796	25.65494	SIO2V	1.5607857	46.008
16	-440.379282	27.044628			48.461
17	-57.443645	14.999995	SIO2V	1.5607857	48.693
18	-75.393191	18.813359			56.902
19	-65.427115	14.999993	SIO2V	1.5607857	58.809
20	-85.530419	0.099998			69.648
21	-227.629071	32.632252	SIO2V	1.5607857	78.348
22	-113.134147	273.116577			82.743
23	-185.855248	-233.116577	REFL		152.166
24	187.338489	273.423654	REFL		143.116
25	277.370431	23.120389	SIO2V	1.5607857	85.671
26	1042.417218	0.999997			83.965
27	232.607011	22.047511	SIO2V	1.5607857	81.953
28	681.476699	7.231337			79.179
29	-4285.293249	15	SIO2V	1.5607857	78.599
30	110.856061	30.36008			72.288
31	-2955.113107	12	SIO2V	1.5607857	71.211
32	119.488431	40.054646			69.309
33	-194.926507	10	SIO2V	1.5607857	71.047
34	-199.009301	0.999987			77.318
35	7009.414576	51.207677	SIO2V	1.5607857	80.754
36	-165.020018	1			95.379
37	-367.692901	34.170188	SIO2V	1.5607857	103.911
38	-197.86104	1			110.595
39	-660.167042	61.861902	SIO2V	1.5607857	118.204
40	-205.342177	1			126.012
41	465.895739	25.776885	SIO2V	1.5607857	126.361
42	-2628.836635	0.099011			125.541
43	8527.260833	40.948445	SIO2V	1.5607857	125.078
44	-271.386413	0			124.177
45	0	0			112.927
46	243.774903	41.095341	SIO2V	1.5607857	107.874
47	-3313.940195	1			104.66
48	83.350349	42.069771	SIO2V	1.5607857	73.803
49	208.118275	1			66.123
50	55.435689	36.911372	SIO2V	1.5607857	44.754
51	0	3	H2OV193	1.43667693	22.888
52	0	0			16.254

TABLE 13A

Aspheric constants				
SRF	2	12	13	21
K	0	0	0	0
C1	5.14E-08	2.47E-07	6.72E-08	-1.49E-08
C2	-3.80E-14	3.12E-11	2.44E-11	5.94E-13
C3	-1.94E-18	-4.32E-15	1.29E-15	-3.47E-17
C4	4.21E-21	1.90E-18	3.61E-19	-4.54E-22
C5	-7.98E-25	-1.98E-22	5.61E-22	-1.73E-25
C6	6.31E-29	2.16E-26	-4.89E-26	3.64E-29
C7	-2.12E-34	-3.06E-31	1.03E-30	-2.29E-33
C8	-1.42E-37	4.40E-34	5.75E-34	1.51E-37
SRF	23	24	30	34
K	-0.4498	-0.304978	0	0
C1	0.00E+00	0.00E+00	-2.20E-07	1.50E-07
C2	-6.07E-16	-4.92E-15	-1.47E-11	1.13E-11
C3	-1.49E-19	4.31E-20	-6.27E-17	5.33E-16
C4	7.27E-24	-3.35E-23	-7.88E-20	5.07E-21

TABLE 13A-continued

Aspheric constants				
SRF	35	41	44	47
C5	-4.02E-28	2.63E-27	3.08E-23	-4.57E-24
C6	9.03E-33	-1.39E-31	-5.95E-27	-2.28E-28
C7	-7.65E-38	3.83E-36	6.01E-31	-1.86E-32
C8	-5.25E-43	-4.49E-41	-2.86E-35	1.72E-35
SRF	35	41	44	47
K	0	0	0	0
C1	-9.41E-08	-6.08E-08	-7.09E-09	-6.42E-08
C2	-6.32E-13	-6.68E-14	4.04E-13	4.46E-12
C3	-4.10E-17	9.32E-17	2.36E-17	-2.33E-16
C4	-1.21E-20	1.98E-21	5.85E-22	1.60E-20
C5	-2.81E-24	-8.05E-26	-5.55E-26	-7.22E-25
C6	8.14E-29	9.24E-32	6.24E-30	1.37E-29
C7	5.30E-33	-1.69E-34	-3.15E-34	3.59E-34
C8	-2.48E-36	6.17E-39	5.34E-39	-9.82E-39

TABLE 14

SURF	RADIUS	THICKNESS	MATERIAL	INDEX	SEMI DIAM.
0	0	35			65
1	264.155216	53.039363	SIO2V	1.5607857	81.542
2	-708.29109	15.80469			84.656
3	198.655375	49.267177	SIO2V	1.5607857	90.333
4	-296.847851	1.032629			89.02
5	188395.3333	12.000019	SIO2V	1.5607857	83.702
6	102.545536	14.972935			73.983
7	142.785896	38.44762	SIO2V	1.5607857	75.139
8	7336.068136	1			73.713
9	106.928203	12.000081	SIO2V	1.5607857	70.401
10	85.093164	1.641753			64.758
11	76.898689	64.469228	SIO2V	1.5607857	64.84
12	-453690.3967	0.494708			50.446
13	151.681366	18.484685	SIO2V	1.5607857	47.423
14	-363.490767	1.138548			43.25
15	-423.037048	10	SIO2V	1.5607857	43.525
16	513.67606	37.991004			45.761
17	-54.826872	16.135714	SIO2V	1.5607857	48.065
18	-76.475326	2.91112			59.373
19	-235.467293	87.250476	SIO2V	1.5607857	69.466
20	-123.833603	270.153968			91.586
21	-189.904942	-230.153968	REFL		154.818
22	175.052549	279.034717	REFL		138.889
23	584.131276	18.62041	SIO2V	1.5607857	71.907
24	111.389792	27.300612			68.759
25	-1516.326452	12.000002	SIO2V	1.5607857	69.364
26	147.378607	31.451574			73.254
27	-362.020208	12	SIO2V	1.5607857	76.176
28	-208.499815	1.640751			80.458
29	2551.550571	58.800655	SIO2V	1.5607857	89.721
30	-162.566587	1			102.174
31	-596.110808	30.823878	SIO2V	1.5607857	111.779
32	-242.915533	1.000004			115.425
33	-1403.743088	66.546477	SIO2V	1.5607857	119.764
34	-315.509469	1.000866			126.177
35	408.007384	50.326509	SIO2V	1.5607857	125.404
36	-350.602433	1			123.958
37	-1141.174919	18.698745	SIO2V	1.5607857	116.585
38	-446.728577	-3.536343			114.214
39	0	4.536343			109.775
40	159.383791	42.840202	SIO2V	1.5607857	100.406
41	3177.374501	1			97.192
42	78.804469	35.408881	SIO2V	1.5607857	68.008
43	170.008236	1			60.471
44	55.898462	33.213214	SIO2V	1.5607857	42.887
45	0	3	H2OV193	1.43667693	22.783
46	0	0			16.253

TABLE 14A

Aspheric constants				
SRF	2	12	13	19
K	0	0	0	0
C1	3.78E-08	3.57E-07	-5.44E-08	3.83E-08
C2	2.66E-12	1.96E-11	-2.40E-11	2.56E-13
C3	-1.97E-16	6.31E-15	8.87E-15	-2.12E-16
C4	2.37E-20	-9.55E-19	-7.06E-18	5.73E-21
C5	-2.23E-24	-2.55E-22	1.67E-21	-1.00E-24
C6	1.48E-28	-8.65E-26	-2.22E-25	2.39E-28
C7	-9.02E-34	2.04E-29	-1.24E-28	1.26E-32
C8	-2.19E-37	-1.29E-32	8.07E-33	-1.88E-36
SRF	21	22	24	25
K	-0.447479	-0.269196	0	0
C1	0.00E+00	0.00E+00	-1.90E-07	-1.07E-07
C2	-5.59E-16	-2.35E-15	-9.95E-12	1.90E-12
C3	3.43E-19	4.59E-21	-5.46E-16	-1.31E-16

TABLE 14A-continued

Aspheric constants				
SRF	28	29	35	38
C4	-3.56E-23	-1.95E-23	1.36E-20	-8.66E-20
C5	2.72E-27	2.32E-27	1.11E-23	6.80E-23
C6	-1.16E-31	-1.42E-31	-1.76E-27	-1.45E-26
C7	2.72E-36	4.52E-36	1.20E-30	3.34E-30
C8	-2.60E-41	-5.19E-41	-6.74E-35	-2.43E-34
SRF	28	29	35	38
K	0	0	0	0
C1	7.94E-08	-4.11E-08	-5.52E-08	-1.11E-08
C2	3.38E-12	-9.39E-13	2.65E-13	8.65E-13
C3	5.77E-17	-3.94E-17	8.42E-17	3.74E-17
C4	-3.25E-20	7.40E-21	3.45E-21	3.35E-21
C5	-2.17E-25	-7.50E-24	-2.31E-25	-4.18E-25
C6	4.68E-30	1.58E-27	2.28E-31	2.67E-29
C7	4.57E-32	-1.55E-31	2.16E-35	-8.47E-34
C8	1.76E-36	6.35E-36	2.04E-39	5.77E-39

TABLE 14A-continued

Aspheric constants	
SRF	41
K	0
C1	-2.87E-08
C2	2.22E-12
C3	-1.63E-16

TABLE 14A-continued

Aspheric constants	
C4	2.19E-20
C5	-1.18E-24
C6	-2.24E-29
C7	5.71E-33
C8	-1.82E-37

TABLE 15

SURF	RADIUS	THICKNESS	MATERIAL	INDEX	SEMI DIAM.
0	0	35			65
1	220.440206	90.193314	SIO2V	1.5607857	82.632
2	-2258.387326	0.099978			86.391
3	191.078269	45.21979	SIO2V	1.5607857	89.197
4	-346.939277	5.038291			87.936
5	-862.704276	11.999955	SIO2V	1.5607857	83.714
6	106.229194	9.360323			75.459
7	124.368852	37.350319	SIO2V	1.5607857	77.121
8	2278.621151	1			75.985
9	130.547812	11.999956	SIO2V	1.5607857	73.073
10	97.147988	1.00002			67.707
11	80.762223	48.20009	SIO2V	1.5607857	67.797
12	-836.844333	0.735286			62.235
13	146.655061	35.349711	SIO2V	1.5607857	56.269
14	-325.682663	5.303246			44.684
15	-237.715704	10	SIO2V	1.5607857	42.717
16	97614.51754	31.113387			44.942
17	-55.878516	25.725119	SIO2V	1.5607857	46.52
18	-84.463856	3.412335			61.171
19	-206.813589	73.554079	SIO2V	1.5607857	68.435
20	-122.996844	265.817443			87.048
21	-188.846432	-225.817443	REFL		158.348
22	170.512895	266.104304	REFL		131.309
23	617.040338	25.358997	SIO2V	1.5607857	77.734
24	-340.978557	1			76.849
25	-575.873317	11.999961	SIO2V	1.5607857	74.709
26	127.056764	29.486792			68.944
27	-919.909026	11.999959	SIO2V	1.5607857	69.382
28	141.247218	33.090673			73.039
29	-327.789177	14.007072	SIO2V	1.5607857	76.032
30	-187.527488	1.002508			80.888
31	1268.298268	66.023641	SIO2V	1.5607857	92.44
32	-172.960759	1			106.476
33	-551.894279	31.122194	SIO2V	1.5607857	114.794
34	-248.493705	2.656579			118.516
35	-5734.547222	50.472484	SIO2V	1.5607857	123.221
36	-350.590281	3.163294			126.143
37	402.358109	43.558538	SIO2V	1.5607857	124.07
38	-381.952357	1			122.788
39	-1074.912987	18.425846	SIO2V	1.5607857	116.413
40	-432.576165	-8.977508			114.127
41	0	9.977508			111.763
42	180.300844	40.797225	SIO2V	1.5607857	101.129
43	6426.19364	1			97.236
44	84.482776	36.262612	SIO2V	1.5607857	70.522
45	215.215262	1			63.323
46	53.879713	33.812201	SIO2V	1.5607857	42.561
47	0	3	H2OV193	1.43667693	22.774
48	0	0			16.253

TABLE 15A

Aspheric constants				
SRF	2	12	13	19
K	0	0	0	0
C1	2.23E-08	1.88E-07	-1.64E-07	1.00E-08
C2	4.33E-12	2.77E-11	-1.41E-12	-4.07E-13
C3	-3.03E-16	-4.05E-15	-5.95E-15	-1.03E-16
C4	2.79E-20	-2.39E-18	-2.18E-18	2.01E-20
C5	-3.36E-24	1.40E-21	6.20E-22	-6.52E-24
C6	2.26E-28	-3.87E-25	-4.85E-26	1.34E-27
C7	-2.80E-33	5.49E-29	2.56E-29	-1.27E-31
C8	-1.73E-37	-3.09E-33	-4.08E-33	5.46E-36

SRF	21	22	25	27
K	-0.468594	-0.258782	0	0
C1	0.00E+00	0.00E+00	1.46E-07	-1.45E-07
C2	1.68E-16	-2.25E-15	-1.14E-11	1.44E-11
C3	2.66E-19	4.56E-19	1.33E-15	1.58E-16
C4	-2.52E-23	-7.45E-23	-1.50E-19	-1.60E-19
C5	1.91E-27	7.82E-27	7.50E-24	6.20E-23
C6	-8.03E-32	-4.50E-31	1.43E-28	-1.02E-26
C7	1.83E-36	1.44E-35	-1.30E-31	1.65E-30
C8	-1.72E-41	-1.76E-40	1.14E-35	-1.59E-34

TABLE 15A-continued

Aspheric constants				
SRF	30	31	37	40
K	0	0	0	0
C1	6.78E-08	-4.22E-08	-5.99E-08	-1.37E-08
C2	5.29E-12	-1.13E-13	4.92E-13	1.20E-12
C3	2.99E-17	-2.12E-16	8.41E-17	1.32E-17
C4	-3.15E-20	3.70E-20	4.25E-21	5.28E-21
C5	3.57E-24	-8.27E-24	-2.88E-25	-5.23E-25
C6	-7.69E-28	1.28E-27	5.24E-31	2.93E-29
C7	6.47E-32	-1.13E-31	5.37E-35	-9.06E-34
C8	-4.37E-37	4.59E-36	1.09E-39	2.79E-39

SRF	43
K	0
C1	-2.10E-08
C2	1.02E-12
C3	-2.69E-18
C4	7.37E-21
C5	-3.90E-25
C6	-7.25E-30
C7	1.51E-33
C8	-1.24E-38

TABLE 16

SURF	RADIUS	THICKNESS	MATERIAL	INDEX	SEMI DIAM.
0	0	35			65
1	203.096237	51.348217	SIO2V	1.5607857	84.153
2	-1160.222766	0.099783			85.288
3	181.493677	43.475858	SIO2V	1.5607857	86.58
4	-341.925526	1.005485			84.893
5	-403.858869	11.999746	SIO2V	1.5607857	83.592
6	109.657938	15.898981			74.771
7	164.368819	44.721199	SIO2V	1.5607857	76.185
8	77645.0807	1			75.386
9	95.919438	11.999975	SIO2V	1.5607857	73.703
10	80.656102	5.826329			67.839
11	79.189771	47.039779	SIO2V	1.5607857	68.939
12	-561.553393	0.099927			64.509
13	139.074465	29.669365	SIO2V	1.5607857	60.109
14	-351.160951	9.311808			53.957
15	-473.600856	10	SIO2V	1.5607857	43.672
16	620.385225	33.601754			45.134
17	-52.784435	14.999981	SIO2V	1.5607857	46.152
18	-74.212989	1.001764			56.339
19	-209.153453	84.778236	SIO2V	1.5607857	63.352
20	-130.926715	255.559533			85.589
21	-187.311637	-215.559533	REFL		162.9
22	158.774035	264.523552	REFL		123.289
23	534.325629	42.990891	SIO2V	1.5607857	83.598
24	-461.508523	1			82.714
25	-5934.605843	12.000066	SIO2V	1.5607857	80.886
26	119.705874	28.744512			76.197
27	1519.32587	12.058263	SIO2V	1.5607857	77.6
28	141.843628	31.894192			79.343
29	-915.926476	20.162536	SIO2V	1.5607857	82.206
30	-205.883678	1.152206			86.328
31	10322.23403	66.866508	SIO2V	1.5607857	93.09
32	-181.874156	1			109.763
33	-421.7412	53.839358	SIO2V	1.5607857	117.145
34	-248.466964	0.999941			128.448
35	-1926.967116	32.001083	SIO2V	1.5607857	134.375
36	-368.835919	1.852034			135.911
37	354.164031	52.480694	SIO2V	1.5607857	136.137
38	-368.63102	1			135.137
39	-828.73625	11.784388	SIO2V	1.5607857	126.567
40	-810.714199	2.572951			124.051
41	0	-1.572951			118.262

TABLE 16-continued

SURF	RADIUS	THICKNESS	MATERIAL	INDEX	SEMI DIAM.
42	154.167114	46.690534	SIO2V	1.5607857	107.326
43	9845.921815	1			104.915
44	90.785618	33.664668	SIO2V	1.5607857	74.672
45	224.183877	1			69.281
46	52.291327	34.416469	SIO2V	1.5607857	43.665
47	0	3	H2OV193	1.43667693	24.683
48	0	0			16.256

TABLE 16A

Aspheric constants				
SRF	2	12	13	19
K	0	0	0	0
C1	8.02E-09	2.78E-07	-1.35E-07	3.82E-08
C2	4.20E-12	3.61E-11	7.65E-12	4.03E-15
C3	-3.80E-16	-3.72E-15	-3.60E-15	-2.87E-16
C4	1.06E-20	-7.33E-19	-1.74E-18	-4.72E-20
C5	9.90E-25	5.93E-22	5.77E-22	4.58E-23
C6	-1.56E-28	-1.48E-25	4.63E-26	-1.86E-26
C7	1.90E-32	2.05E-29	-1.32E-29	3.54E-30
C8	-9.78E-37	-1.01E-33	-4.75E-35	-2.52E-34
SRF	21	22	25	27
K	-0.448249	-0.301702	0	0
C1	0.00E+00	0.00E+00	1.70E-07	-1.21E-07
C2	-6.31E-16	-1.93E-15	-1.40E-11	1.82E-11
C3	3.14E-19	-1.03E-18	1.35E-15	6.67E-16
C4	-2.63E-23	1.15E-22	-2.19E-19	8.15E-20
C5	1.70E-27	-7.31E-27	1.48E-23	3.45E-24
C6	-6.12E-32	1.26E-31	-6.97E-28	3.08E-27
C7	1.22E-36	8.96E-36	-7.36E-32	-5.45E-31
C8	-1.00E-41	-2.90E-40	1.12E-35	1.66E-35
SRF	30	31	37	40
K	0	0	0	0
C1	4.69E-08	-4.37E-08	-5.26E-08	-3.16E-08
C2	4.01E-12	-6.80E-13	1.78E-13	1.40E-12
C3	-2.83E-17	-2.42E-16	6.38E-17	-1.09E-17
C4	-6.69E-22	3.15E-20	3.79E-21	6.35E-21
C5	4.14E-24	-5.56E-24	-1.89E-25	-5.33E-25
C6	-1.25E-27	3.74E-28	-3.40E-31	2.59E-29
C7	1.44E-31	-9.55E-33	1.88E-35	-6.08E-34
C8	-6.05E-36	-7.20E-37	1.27E-39	8.73E-40
SRF	43			
K	0			
C1	7.85E-10			
C2	6.39E-13			
C3	-1.45E-17			
C4	3.10E-21			

TABLE 16A-continued

Aspheric constants	
C5	3.20E-25
C6	-5.68E-29
C7	3.00E-33
C8	-3.92E-38

TABLE 17

FIG.	λ	NA	Yobj	OAL1/mm	OAL3/mm	MG
2	193	1.2	66	430.04	548.46	0.78
4	193	1.2	66	450.79	582.74	0.77
7	193	1.2	66	466.38	574.00	0.81
9	193	1.2	66	460.81	591.60	0.78
10	193	1.2	66	500.44	518.13	0.97
11	193	1.2	66	489.34	534.12	0.92
12	193	1.3	66	425.56	613.66	0.69
13	193	1.3	65	472.62	544.26	0.87
14	193	1.3	65	513.08	498.55	1.03
15	193	1.3	65	521.66	502.53	1.04
16	193	1.35	65	492.88	541.56	0.91

TABLE 18

FIG.	λ	NA	Yobj	R _{LL} /mm	T _{LL} /mm	DIA _{LL} /mm	LL1	LL2
2	193	1.2	66	49.61	31.48	75.96	0.63	1.53
4	193	1.2	66	50.00	29.33	73.75	0.59	1.48
7	193	1.2	66	87.43	40.06	100.36	0.46	1.15
9	193	1.2	66	77.07	38.57	95.24	0.50	1.24
10	193	1.2	66	72.15	41.29	96.69	0.57	1.34
11	193	1.2	66	67.79	39.96	92.98	0.59	1.37
12	193	1.3	66	61.19	42.23	98.47	0.69	1.61
13	193	1.3	65	55.44	36.91	89.08	0.67	1.61
14	193	1.3	65	55.90	33.21	85.45	0.59	1.53
15	193	1.3	65	53.88	33.81	84.84	0.63	1.57
16	193	1.35	65	52.29	34.42	87.11	0.66	1.67

TABLE 19

FIG.	λ	NA	Yobj	COMP1	COMP2	COMP3	N1AS	N2AS	ASR
2	193	1.2	66	9.18	138	46	0	1	0
4	193	1.2	66	9.29	149	50	0	1	0
7	193	1.2	66	10.6	244	81	2	5	0.40
9	193	1.2	66	10.6	232	77	1	5	0.20
10	193	1.2	66	9.52	219	73	0	5	0
11	193	1.2	66	9.34	215	72	3	5	0.60
12	193	1.3	66	9.70	233	78	2	6	0.33
13	193	1.3	65	9.08	236	79	4	6	0.67

TABLE 19-continued

FIG.	λ	NA	Yobj	COMP1	COMP2	COMP3	N1AS	N2AS	ASR
14	193	1.3	65	9.03	208	69	4	7	0.57
15	193	1.3	65	8.94	214	72	4	7	0.57
16	193	1.35	65	9.11	218	73	4	7	0.57

TABLE 20

FIG.	β_2	β_3	f3(L1 . . . 2)/mm	f3(L1 . . . 2)/mm	AS-IS/TT	CRA(M)/°
2	0.868	0.168	-150.018		0.172	61.23
4	0.942	0.166	-212.248		0.104	62.77
7	0.869	0.171		-441.036	0.146	61.08
9	0.969	0.168		-388.381	0.123	62.95
10	0.960	0.154		-274.736	0.128	62.27
11	1.009	0.147		-249.046	0.137	64.57
12	1.286	0.122		-247.036	0.118	70.75
13	1.190	0.117		-712.866	0.100	68.88
14	1.045	0.126	-114.534		0.097	69.2
15	1.044	0.129	-368.766		0.101	69.3
16	0.991	0.134	-430.318		0.095	71.21

TABLE 21

FIG.	K7	K7a	DIA ₃₁ /DIA _{AS}	K9	K10	K11	CBA1/°	CBA3/°	DIA _{AS} /DIA _{P1}
2	Y	Y	0.833	Y	Y	N	4.62	7.45	2.135
4	Y	Y	1.050	Y	Y	N	2.17	7.17	1.448
7	N	Y	0.709	Y	Y	Y	1.08	0.88	3.349
9	N	Y	0.792	Y	Y	Y	1.32	1.04	2.837
10	N	Y	0.746	Y	Y	N	3.49	1.68	2.539
11	N	Y	0.789	Y	Y	N	3.25	1.09	2.534
12	N	Y	0.746	Y	Y	Y	7.11	1.42	3.086
13	N	Y	0.758	Y	Y	Y	5.29	1.62	2.188
14	Y	Y	0.667	Y	Y	Y	4.04	4.75	2.007
15	Y	Y	0.695	Y	Y	Y	5.28	2.80	2.353
16	Y	Y	0.722	Y	Y	Y	6.60	2.29	1.950

1-49. (canceled)

50. A catadioptric projection objective for imaging a pattern provided in an object plane of the projection objective onto an image plane of the projection objective comprising:

- a first objective part that includes one or more refractive optical elements to image the pattern provided in the object plane into a first intermediate image;
- a second objective part that consists of reflective optical elements including at least one concave mirror to image the first intermediate image into a second intermediate image; and
- a third objective part that includes one or more refractive optical elements to image the second intermediate image onto the image plane;

wherein an aperture stop is positioned in the third objective part between a region of maximum beam diameter and the image surface in a region of a converging beam.

51. Projection objective according to claim 50, wherein only three positive lenses are placed between the aperture stop and the image surface.

52. Projection objective according to claim 50, wherein a first concave mirror having a first continuous mirror surface and at least one second concave mirror having a second continuous mirror surface are arranged in the second objective part; and

pupil surfaces are formed between the object plane and the first intermediate image, between the first and the second intermediate images and between the second intermediate image and the image plane.

53. Projection objective according to claim 50,

wherein the projection objective includes at least one double asphere having a first aspheric surface and a second aspheric surface immediately adjacent to the first aspheric surface, the double asphere being formed by facing adjacent aspheric surfaces of two consecutive lenses.

54. Projection objective according to claim 53, wherein an axial distance between the first aspheric surface and the second aspheric surface of the double asphere is smaller than an axial thickness of a thinner of two consecutive lenses forming the double asphere.

55. Projection objective according to claim 53, wherein the third objective part includes at least one double asphere.

56. Projection objective according to claim 55, wherein the double asphere is positioned optically between the second intermediate image and the pupil surface of the third objective part.

57. Projection objective according to claim 53, wherein the first objective part includes at least one double asphere.

58. Projection objective according to claim **57**, wherein the double asphere is positioned optically close to or at a pupil surface of the first objective part.

59. Projection objective according to claim **53**, wherein the first objective part and the third objective part each include at least one double asphere.

60. Projection objective according to claim **50**, wherein a first concave mirror having a first continuous mirror surface and at least one second concave mirror having a second continuous mirror surface are arranged in the second objective part; and

pupil surfaces are formed between the object plane and the first intermediate image, between the first and the second intermediate images and between the second intermediate image and the image plane.

61. Projection objective according to claim **50**, wherein at least one of 8 and 9 consecutive lenses upstream of the image surface have positive refractive power.

62. Projection objective according to claim **50**, wherein an image side numerical aperture NA is larger than 1.2.

* * * * *